



**SUBMITTAL TO THE FLOOD CONTROL AND WATER CONSERVATION DISTRICT BOARD
COUNTY OF RIVERSIDE, STATE OF CALIFORNIA**

FROM: General Manager-Chief Engineer

111 B

SUBMITTAL DATE:
September 25, 2012

SUBJECT: Pyrite Channel Bypass, Stage 1
Project No. 1-0-00109-01
District 2/District 2

RECOMMENDED MOTION:

1. Adopt Resolution No. F2012-21 which sets November 27, 2012 as the date for a Public Hearing concerning the construction of the above referenced project in accordance with Section 18 of the District Act and gives Notice of Intent to Adopt a Mitigated Negative Declaration in accordance with the California Environmental Quality Act (CEQA); and
2. Direct the Clerk of the Board to advertise and post said notice of public hearing and intent to adopt a Mitigated Negative Declaration in accordance with Section 18 of the District Act and CEQA.

BACKGROUND:

See Page 2.

FINANCIAL:

N/A

WARREN D. WILLIAMS
General Manager-Chief Engineer

FINANCIAL DATA

Current F.Y. District Cost:	N/A	In Current Year Budget:	N/A
Current F.Y. County Cost:	N/A	Budget Adjustment:	N/A
Annual Net District Cost:	N/A	For Fiscal Year:	N/A

SOURCE OF FUNDS: N/A

Positions To Be Deleted Per A-30	<input type="checkbox"/>
Requires 4/5 Vote	<input type="checkbox"/>

C.E.O. RECOMMENDATION:

APPROVE

BY:
Michael R. Shetler

County Executive Office Signature

FORM APPROVED COUNTY COUNSEL
BY:
MICHELLE CLACK
DATE: 9/5/12

Policy
 Policy
 Consent
 Consent
 Dep't Recomm.:
 Per Exec. Ofc.:

Prev. Agn. Ref.:

District: 2nd/2nd

Agenda Number:

11.1

**FLOOD CONTROL AND WATER CONSERVATION DISTRICT BOARD SUBMITTAL
COUNTY OF RIVERSIDE, STATE OF CALIFORNIA**

SUBJECT: Pyrite Channel Bypass, Stage 1
Project No. 1-0-00109-01
District 2/District 2

SUBMITTAL DATE: September 25, 2012

Page 2

BACKGROUND:

Section 18 of the District's Enabling Act requires the Board to hold a Public Hearing for the purpose of considering all comments regarding any proposed facilities before authorizing the construction of such facilities.

The Pyrite Channel Bypass Project (Project) entails the construction and subsequent maintenance of an underground storm drain system and associated street improvements. The proposed storm drain project consists of approximately 1,700 lineal feet of reinforced concrete pipe (RCP) that will convey minor flows from the District's existing concrete lined trapezoidal Pyrite Channel and discharge them to the District's existing concrete lined rectangular Jurupa Channel. Street improvements along Pyrite Street between Jurupa Road and Lone Trail will ensure that the storm drain system functions properly.

In June 2011, the Redevelopment Agency for the County of Riverside (RDA) prepared a final initial study for a project entitled "Pyrite Street Improvement Project" in accordance with the California Environmental Quality Act (CEQA). The Pyrite Channel Bypass, Stage 1 Project (Project) was included in RDA's initial study. With the recent ruling by the California Supreme Court to phase out economic development programs, RDA has decided not to construct their project or adopt a Mitigated Negative Declaration based on the findings in the initial study. In order to alleviate flooding in the area, the District has decided to assume the CEQA lead agency role for the portion of the "Pyrite Street Improvement Project" that includes the storm drain system and associated street improvements.

A new MND and IS was prepared by the District to reflect the lead agency change, smaller scope of the project, and changes in local jurisdiction (e.g., incorporation of the City of Jurupa Valley). However, since the RDA's IS analyzed the proposed Project impacts, applicable portions of the RDA's IS have been incorporated into the District's IS.

In accordance with the State guidelines implementing the CEQA, the General Manager-Chief Engineer of the District has found that the proposed project will not have a significant adverse effect on the environment and has completed a Mitigated Negative Declaration which will not be final until approved and adopted by this Board.

1
2 BOARD OF SUPERVISORS

RIVERSIDE COUNTY FLOOD CONTROL
AND WATER CONSERVATION DISTRICT

3 **RESOLUTION NO. F2012-21**
4 **SETTING A PUBLIC HEARING DATE FOR**
5 **PYRITE CHANNEL BYPASS, STAGE 1 PROJECT**
6 **AND GIVING NOTICE OF INTENT TO ADOPT A**
7 **MITIGATED NEGATIVE DECLARATION THEREFOR**
8 **IN ACCORDANCE WITH SECTION 18 OF THE DISTRICT ACT**
9 **AND THE CALIFORNIA ENVIRONMENTAL QUALITY ACT (CEQA)**

10 WHEREAS, this Board intends to undertake a project within the city of Jurupa Valley,
11 designated as Pyrite Channel Bypass, Stage 1 Project ["Proposed Project"]; and

12 WHEREAS, the Proposed Project is generally located along Pyrite Street from Lone
13 Trail to approximately 60 feet south of Jurupa Road; and

14 WHEREAS, the Proposed Project consists of the construction and subsequent operation
15 and maintenance of approximately 1,700 lineal feet of underground storm drain system and street
16 improvements; and

17 WHEREAS, reference is made to the engineering cost estimate for the Proposed Project,
18 included in the "Engineer's Statement" on file with the Clerk of the Board; and

19 WHEREAS, reference is made to a map dated June 2012, bearing the name and showing
20 the general location and typical section of the Proposed Project which is also on file with the
21 Clerk of the Board; and

22 WHEREAS, the Redevelopment Agency (RDA) for the County of Riverside prepared a
23 California Environmental Quality Act (CEQA) initial study that included the Proposed Project;
24 and

25 WHEREAS, with the recent ruling by the California Supreme Court to phase out
26 economic development programs, RDA has decided not to construct their project or adopt a
27 Mitigated Negative Declaration based on the findings in the initial study; and

28 WHEREAS, in order to alleviate flooding in the area, the District has assumed the CEQA
Lead Agency role for the Proposed Project; and

FORM APPROVED COUNTY COUNSEL
BY:  DATE: 9/5/12
MICHELLE CLACK

1 WHEREAS, the General Manager-Chief Engineer of the District has found that the
2 Proposed Project will not have a significant adverse effect on the environment and has prepared
3 a Mitigated Negative Declaration which will not become final until adopted by this Board; and

4 WHEREAS, any person wishing to comment on the Proposed Project or the Mitigated
5 Negative Declaration may do so in writing between the date of this notice and the public hearing,
6 or may appear and be heard at the time and place noted below; and

7 WHEREAS, in a subsequent legal challenge any person may be limited to raising only
8 those issues he, she or someone else raised at the public hearing described in this notice, or in
9 written comments delivered before or at the public hearing; and

10 WHEREAS, prior to making a decision on the Proposed Project or the Mitigated
11 Negative Declaration, this Board will consider all written and oral comments; and

12 WHEREAS, the above-listed documents can be inspected at the District office, 1995
13 Market Street, Riverside, California 92501 and written comments will be received at the above
14 address.

15 NOW, THEREFORE, BE IT RESOLVED, DETERMINED AND ORDERED by the
16 Board of Supervisors of the Riverside County Flood Control and Water Conservation District in
17 regular session assembled on September 25, 2012 that:

18 1. A public hearing concerning the intent to approve the Proposed Project and adopt
19 the Mitigated Negative Declaration will be held at 11:00 a.m. on November 27, 2012, at the
20 meeting room of this Board, 1st Floor, County Administrative Center, 4080 Lemon Street,
21 Riverside, California 92501, at which time all public comment shall be heard.

22 2. A copy of this resolution and copies of the above listed documents shall be posted
23 at least thirty (30) days before said hearing at the City of Jurupa Valley City Hall, 8304 Limonite
24 Avenue, Suite "M", Jurupa Valley, California 92509.

25 3. A copy of this resolution shall be posted at least thirty (30) days before said hearing
26 at the Riverside County Clerk and Recorder's Office, 2724 Gateway Drive, Riverside, California
27 92507.

1
2
3
4
5
6
7
8
9
10
11
12
13
14
15
16
17
18
19
20
21
22
23
24
25
26
27
28

4. The Clerk of this Board is directed to cause a copy of this resolution to be published twice, once at least thirty (30) days before said hearing, and once seven (7) days following the initial publication in a newspaper of general circulation in accordance with Section 18 of the District Act and CEQA.

**PYRITE CHANNEL BYPASS, STAGE 1
PROJECT NO. 1-0-00109-01**

ENGINEER'S STATEMENT

The proposed project is located within the city of Jurupa Valley in Riverside County, California. The proposed project entails the construction and subsequent maintenance of an underground storm drain system and associated street improvements. The proposed storm drain project consists of approximately 1,700 lineal feet of reinforced concrete pipe (RCP) that will convey minor flows from the District's existing concrete lined trapezoidal Pyrite Channel and discharge them to the District's existing concrete lined rectangular Jurupa Channel. Street improvements along Pyrite Street between Jurupa Road and Lone Trail will ensure that the storm drain system functions properly. Utility services to be relocated may include cable, telephone, gas, water and sewer within the road rights-of-way. When completed, this storm drain system will provide flood protection for neighboring residential areas.

The proposed project area may be found within Township 2 South, Range 6 West, Sections 12 and 13 of the Fontana 7.5 Series USGS Topographic Quadrangle map. The cost of the proposed project is approximately \$940,000.

SECTION 18 PUBLIC HEARING MAP



PYRITE CHANNEL BYPASS
STAGE 1
1-0-0109
JUNE 2012

PROJECT
LOCATION

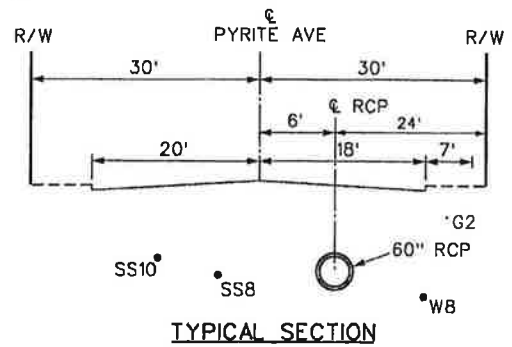
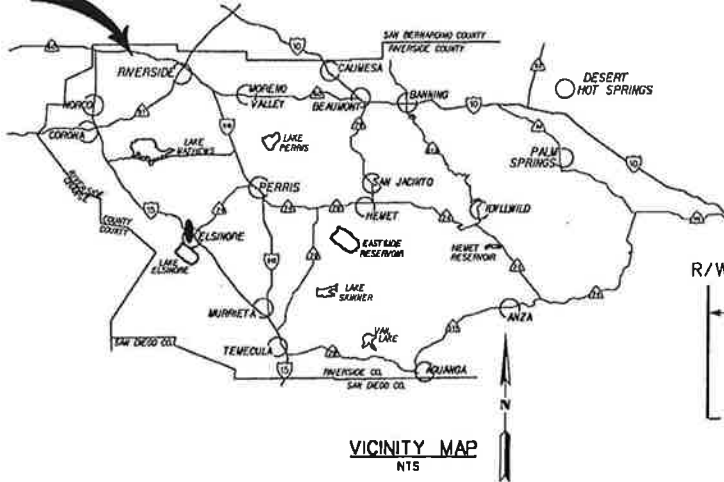

LOCATION MAP
N.T.S.

