

FORM APPROVED COUNTY COUNSEL  
 BY: GREGORY P. PRIAMOS DATE: 9/21/15

**SUBMITTAL TO THE BOARD OF SUPERVISORS  
 COUNTY OF RIVERSIDE, STATE OF CALIFORNIA**



**FROM:** TLMA – Transportation Department

**SUBMITTAL DATE:**  
 August 21, 2015

**SUBJECT:** Accept the Low Bid and Award the Contract for the Construction of a Traffic Signal at the Intersection of Serfas Club Drive and Monterey Peninsula Drive in the Community of Coronita. 2<sup>nd</sup> District; [\$400,086 total]; [\$5,500 ongoing]; Local Funds 100%

**RECOMMENDED MOTION:** That the Board of Supervisors:

1. Approve one addendum to the plans and specifications issued prior the July 8, 2015, bid opening; and
2. Accept the low bid of DBX, Inc. of Temecula, CA in the amount of \$400,086; and
3. Award the contract to DBX, Inc. and authorize the Chairman of the Board to execute the contract documents; and
4. Approve the project's proposed budget as shown on Attachment "A."

Departmental Concurrence

Patricia Romo  
 Patricia Romo  
 Assistant Director of Transportation

Juan C. Perez  
 Juan C. Perez  
 Director of Transportation and Land Management

JCP:jj:rr

FINANCIAL DATA	Current Fiscal Year:	Next Fiscal Year:	Total Cost:	Ongoing Cost:	POLICY/CONSENT (Per Exec. Office)
<b>COST</b>	\$ 400,086	\$	\$ 400,086	\$ 5,500	Consent <input type="checkbox"/> Policy <input checked="" type="checkbox"/>
<b>NET COUNTY COST</b>	\$ 0	\$ 0	\$ 0	\$ 0	

**SOURCE OF FUNDS:** West County DIF Signal Mitigation Fund (69.7%), City of Corona (30.3%). There are no General Funds used in this project.  
**Budget Adjustment:** No  
**For Fiscal Year:** 15/16

**C.E.O. RECOMMENDATION:**  
 APPROVE  
 BY: Rohini Dasika  
 Rohini Dasika

County Executive Office Signature

**MINUTES OF THE BOARD OF SUPERVISORS**

- A-30
- 4/5 Vote
- Positions Added
- Change Order

**Prev. Agn. Ref.:** 6/16/15, Item 3-55 | **District:** 2 | **Agenda Number:**

**3-49**

**SUBMITTAL TO THE BOARD OF SUPERVISORS, COUNTY OF RIVERSIDE, STATE OF CALIFORNIA**

**FORM 11:** Accept the Low Bid and Award the Contract for the Construction of a Traffic Signal at the Intersection of Serfas Club Drive and Monterey Peninsula Drive in the Community of Coronita. 2nd District; [\$400,086 total]; [\$5,500 ongoing]; Local Funds 100%

**DATE:** August 21, 2015

**PAGE:** 2 of 3

**BACKGROUND:**

**Summary**

By Minute Order dated June 16, 2015 (Agenda Item 3-55), the Board of Supervisors authorized the Clerk of the Board to advertise for the installation of a traffic signal, lighting, and intersection improvements at the intersection of Serfas Club Drive and Monterey Peninsula Drive in the community of Coronita.

Serfas Club Drive is a four-lane facility (two northbound lanes, one southbound lane, and one two-way left-turn lane) that travels in the north-south direction. Monterey Peninsula Drive is a two-lane residential street that travels in the east-west directions.

During the advertisement period, one addendum was issued to all registered plan holders as a supplement to the plans and specifications. Bidders were required to acknowledge and take into account the issued addendum on their Contractor's Bid in order to be considered for award. The addendum was issued to clarify and modify the approved contract documents. The addendum is attached and designated as Addendum No. 1.

Eight bids were received on July 8, 2015, ranging from \$400,086 to \$452,406. The basis for the selection of a contractor is the lowest responsive and responsible bid. The lowest responsible bid was submitted by DBX, Inc. in the amount of \$400,086, which is \$64,451 (19%) higher than the Engineer's Estimate. Bid prices received higher than the Engineer's Estimate costs are due to higher than expected prices of traffic signal components and other construction materials.

The contractor is qualified to perform the work as outlined in the bid, has executed the contract, and has provided bonds and insurance documents, which meet the requirements of the contract.

Project Number: C5-0073

**Impact on Residents and Businesses**

The new traffic signal and lighting will improve traffic safety by providing a controlled intersection at Serfas Club Drive and Monterey Peninsula Drive and signal coordination with other signals on Serfas Club Drive to help facilitate traffic flow. The new signal will improve access for the residents along Monterey Peninsula Drive to Serfas Club Drive.

The construction duration set for this project is 40 working days, approximately eight weeks; construction is anticipated to be completed by January 2016.

**SUPPLEMENTAL:**

**Additional Fiscal Information**

The contract is recommended to be awarded to DBX, Inc. for the total amount of \$400,086. The project is funded with West County Development Impact Fee (DIF) Signal Mitigation funds and City of Corona Developer Fee funds that City collected from Thomas Ranch Development located at the south west corner of Serfas Club Drive and Palisades Drive.

The DIF program, which is governed under Ordinance 659, allows for the use of DIF funds for traffic signal facilities.

Annual traffic signal operation and maintenance costs are estimated at \$5,500 to be funded by Gas Tax.

There are no General Funds used in this project.

**Contract History and Price Reasonableness**

Eight competitive bids were received, ranging from \$400,086 to \$452,406. Based on the number of bids received, the low bid of \$400,086 is reasonable for the construction of the traffic signal and lighting.

**SUBMITTAL TO THE BOARD OF SUPERVISORS, COUNTY OF RIVERSIDE, STATE OF CALIFORNIA**  
**FORM 11:** Accept the Low Bid and Award the Contract for the Construction of a Traffic Signal at the Intersection of Serfas Club Drive and Monterey Peninsula Drive in the Community of Coronita. 2nd District; [\$400,086 total]; [\$5,500 ongoing]; Local Funds 100%

**DATE:** August 21, 2015

**PAGE:** 3 of 3

## **ATTACHMENTS**

Vicinity Map  
Attachment "A"  
Contract/Lease/Purchase Summary Data  
Summary of Bids  
Addendum Number 1  
Contract

COUNTY OF RIVERSIDE  
TRANSPORTATION DEPARTMENT

SERFAS CLUB DR  
AND  
MONTEREY PENINSULA DR

TRAFFIC SIGNAL AND LIGHTING  
IN THE COMMUNITY OF CORONITA

PROJECT No. C5-0073

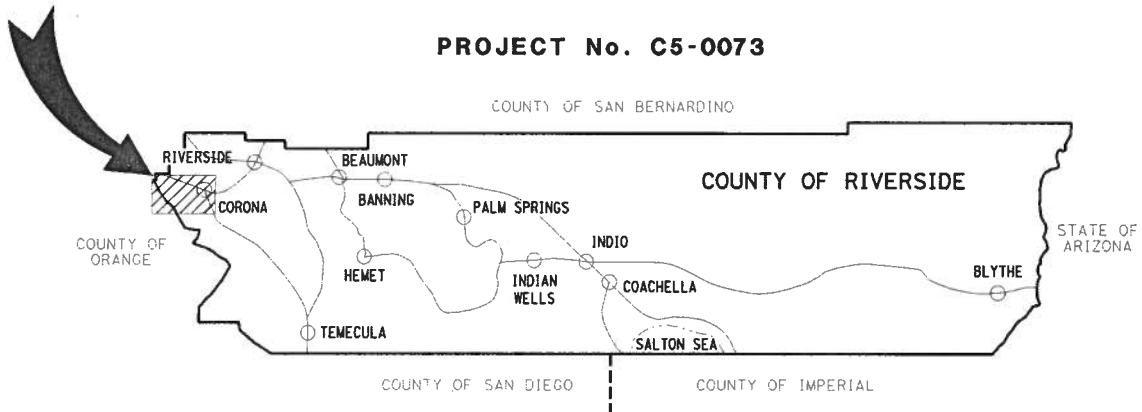

**VICINITY MAP**  
TOWNSHIP 39 RANGE 7W SECTION 28  
COUNTY ROAD BOOK PAGE No. 21-A

# Attachment "A"

Riverside County Transportation Department

Project: **Serfas Club Dr and Monterey Peninsula Traffic Signal and Lighting**

Project No.(s): **C5-0073**

### Project Costs and Budget

Activity	Incurring Costs	Projected Costs	Total Costs	Existing Budget	Proposed Budget
Preliminary Survey	10,171	829	11,000	10,000	11,000
Environmental	1,069	931	2,000	3,000	2,000
Design	73,717	283	74,000	65,000	74,000
Right-of-way					
Utilities					
Construction	3,755	400,086	403,841		
Construction Contingency 10%		40,009	40,009	360,000	476,000
Signal Pole Equipment	31,451	549	32,000		
Construction Engineering & Inspection 15.0%	7,497	52,516	60,013	60,000	60,000
Construction Survey 10.0%		40,009	40,009	30,000	40,000
<b>Totals:</b>	<b>127,659</b>	<b>535,212</b>	<b>662,871</b>	<b>528,000</b>	<b>663,000</b>

### Project Funding

Code	Name	Existing Budget	Proposed Budget
369	West County DIF Signal Mitigation Fund	528,000	541,598
990	Developer Fee		121,402
<b>Totals</b>		<b>528,000</b>	<b>663,000</b>

### Comments

**Form 11 Attachment**

**Contract/Lease/Purchase Summary Data**

**Contract (for Services)**

- Approval/Renewal
- Sole Source
- Personal Services
- Independent Contractor
- Other than Low Bid
- Change Order
- Public Works

**Lease**

- Approval/Renewal
- Multi-Year Lease
- Equipment
- Real Property
- Change Order

**Purchase (for Materials)**

- Sole Source
- Other than Low Bid
- Change Order

**Selection Committee Member Names (RFPs Only)**

<b>User Department:</b>	Transportation Department
-------------------------	---------------------------

N/A

<b>Vendor/Lessor Name:</b>	DBX, Inc.
----------------------------	-----------

**Minority Status:**  M  W  DV  None

<b>Vendor/Lessor Location:</b>	Temecula, CA
--------------------------------	--------------

**Local Preference Applied:**  Yes  No  N/A

**Local Preference Award Cost \$**  
(5% maximum preference)

**Local Preference FYTD:** Cost \$ # of Orders

**Applicable Board Policy #**

**Comments:**

**RFQ/RFP Process:**

Date Mailed:  
Response Date:  
# of Responses:  
# of Qualified Responses:

**Bidding Process:**

Bid Range: \$ 400,086.00 to \$ 452,406.90  
Local Bid Range: N/A  
Responsive and Responsible Bid Range: \$ 400,086.00 to \$ 452,406.90

**Contract/Lease Renewals Only**

Existing Agreement Items

Proposed Agreement Items

1. Rates
2. Terms
3. Conditions
4. Legal Issues
5. Accountability
6. Utilities

(Continue on blank sheet if necessary)

**NOTE: COMPETITIVELY BID PUBLIC WORKS CONTRACT**

**Riverside County Transportation Department  
Summary of Bids**

Advertised: June 16, 2015 (Agenda Item: 3-55)  
Addenda: 1 (6/23/15)  
Bids Open: 2 pm Date: Wednesday, July 8, 2015

**PROJECT: Serfas Club Drive and Monterey Peninsula Drive  
Traffic Signal and Lighting Project  
In the Community of Coronita**

**PROJECT No. C5-0073**

BASE BID SCHEDULE		COUNTY'S ESTIMATE				DBX, Inc. Temecula, CA 92590		
ITEM NO.	ITEM CODE	CONTRACT ITEM	UNITS	QUANTITY	UNIT PRICE	ENG ESTIMATE	BID UNIT PRICE	BID ESTIMATE
1	130200	PREPARE WATER POLLUTION CONTROL PROGRAM	LS	1	5,000.00	5,000.00	900.00	900.00
2	120100	TRAFFIC CONTROL SYSTEM	LS	1	8,000.00	8,000.00	15,000.00	15,000.00
3	170101	DEVELOP WATER SUPPLY	LS	1	2,000.00	2,000.00	1,000.00	1,000.00
4	066100	DUST CONTROL	LS	1	4,000.00	4,000.00	3,500.00	3,500.00
5	160101	CLEARING AND GRUBBING	LS	1	15,000.00	15,000.00	4,000.00	4,000.00
6	190101	ROADWAY EXCAVATION	CY	50	75.00	3,750.00	248.00	12,400.00
7	153103	COLD PLANE ASPHALT CONCRETE PAVEMENT	SQYD	675	5.00	3,375.00	11.00	7,425.00
8	390130	HOT MIX ASPHALT	TON	150	80.00	12,000.00	225.00	33,750.00
9	017316	MINOR CONCRETE (CURB RAMP) (CRS 403 - CASE B)	EA	4	4,000.00	16,000.00	3,200.00	12,800.00
10	017317	MINOR CONCRETE (CROSS-GUTTER AND SPANDREL)	SQFT	1,700	9.00	15,300.00	9.00	15,300.00
11	000001	ITEM DELETED BY ADDENDUM	---	---	---	---	---	---
12	731521	MINOR CONCRETE (SIDEWALK)	SQFT	100	9.00	900.00	18.44	1,844.00
13	017305	MINOR CONCRETE (CURB AND GUTTER) (CRS 201)	LF	40	20.00	800.00	36.00	1,440.00
14	513553	RETAINING WALL (MASONRY WALL) [PER CONSTRUCTION NOTE 9]	LF	50	200.00	10,000.00	207.00	10,350.00
14.A	513553	RETAINING WALL (MASONRY WALL) [PER CONSTRUCTION NOTE 13]	LF	30	300.00	9,000.00	258.00	7,740.00
14.B	839514	HAND RAILING [PER APWA STD 606-3, TYPE B]	LF	60	60.00	3,600.00	50.00	3,000.00
15	000003	REPLACE DAMAGED PLANTS/SOD	LS	1	1,000.00	1,000.00	2,500.00	2,500.00
16	860201	SIGNAL AND LIGHTING	LS	1	174,000.00	174,000.00	216,531.00	216,531.00
17	150710	REMOVE TRAFFIC STRIPE	LF	300	0.30	90.00	0.60	180.00
18	150715	REMOVE THERMOPLASTIC PAVEMENT MARKING	SQFT	600	0.30	180.00	2.90	1,740.00
19	840656	PAINT TRAFFIC STRIPE (2-COAT)	LF	8,300	0.30	2,490.00	0.25	2,075.00
20	840515	THERMOPLASTIC PAVEMENT MARKING	SQFT	550	5.00	2,750.00	4.30	2,365.00
21	850111	PAVEMENT MARKER (RETROREFLECTIVE)	EA	210	5.00	1,050.00	2.90	609.00
22	566011	ROADSIDE SIGN - ONE POST	EA	2	350.00	700.00	272.00	544.00
23	150742	REMOVE (AND SALVAGE) EXISTING SIGN (AND POST)	EA	11	150.00	1,650.00	63.00	693.00
24	015602	FUNDING AWARENESS SIGN	EA	2	1,500.00	3,000.00	1,200.00	2,400.00
25	010602	MISCELLANEOUS WORK (AS DIRECTED)	FA	1	30,000.00	30,000.00	30,000.00	30,000.00
26	019901	DE-MOBILIZATION	LS	1	10,000.00	10,000.00	10,000.00	10,000.00
<b>PROJECT TOTAL, ITEMS 1 - 26</b>						<b>335,635.00</b>		<b>400,086.00</b>

**Riverside County Transportation Department  
Summary of Bids**

**PROJECT: Serfas Club Drive and Monterey Peninsula Drive  
Traffic Signal and Lighting Project  
In the Community of Coronita**

Advertised: June 16, 2015 (Agenda Item: 3-55)

Addenda: 1 (6/23/15)

Bids Open: 2 pm Date: Wednesday, July 8, 2015

PROJECT No. C5-0073

BASE BID SCHEDULE		2			3		
ITEM NO.	ITEM CODE	CONTRACT ITEM	UNITS	QUANTITY	BID UNIT PRICE	BID ESTIMATE	Hilcrest Contracting Corona, CA 92878
1	130200	PREPARE WATER POLLUTION CONTROL PROGRAM	LS	1	1,309.00	1,309.00	4,000.00
2	120100	TRAFFIC CONTROL SYSTEM	LS	1	20,000.00	20,000.00	20,000.00
3	170101	DEVELOP WATER SUPPLY	LS	1	3,000.00	3,000.00	2,000.00
4	066100	DUST CONTROL	LS	1	4,000.00	4,000.00	1,000.00
5	160101	CLEARING AND GRUBBING	LS	1	10,000.00	10,000.00	15,000.00
6	190101	ROADWAY EXCAVATION	CY	50	160.00	8,000.00	115.00
7	153103	COLD PLANE ASPHALT CONCRETE PAVEMENT	SQYD	675	11.00	7,425.00	11.00
8	390130	HOT MIX ASPHALT	TON	150	170.00	25,500.00	157.00
9	017316	MINOR CONCRETE (CURB RAMP) (CRS 403 - CASE B)	EA	4	4,269.00	17,076.00	6,200.00
10	017317	MINOR CONCRETE (CROSS-GUTTER AND SPANDREL)	SQFT	1,700	13.87	23,579.00	34.00
11	000001	ITEM DELETED BY ADDENDUM	----	----	----	----	----
12	731521	MINOR CONCRETE (SIDEWALK)	SQFT	100	10.67	1,067.00	27.00
13	017305	MINOR CONCRETE (CURB AND GUTTER) (CRS 201)	LF	40	69.00	2,760.00	50.00
14	513553	RETAINING WALL (MASONRY WALL) [PER CONSTRUCTION NOTE 9]	LF	50	503.00	25,150.00	145.00
14.A	513553	RETAINING WALL (MASONRY WALL) [PER CONSTRUCTION NOTE 13]	LF	30	371.00	11,130.00	220.00
14.B	839514	HAND RAILING [PER APWA STD 606-3, TYPE B]	LF	60	100.00	6,000.00	100.00
15	000003	REPLACE DAMAGED PLANTS/SOD	LS	1	5,400.00	5,400.00	6,000.00
16	860201	SIGNAL AND LIGHTING	LS	1	194,000.00	194,000.00	177,000.00
17	150710	REMOVE TRAFFIC STRIPE	LF	300	0.64	192.00	1.00
18	150715	REMOVE THERMOPLASTIC PAVEMENT MARKING	SQFT	600	3.09	1,854.00	2.75
19	840656	PAINT TRAFFIC STRIPE (2-COAT)	LF	8,300	0.26	2,158.00	0.40
20	840515	THERMOPLASTIC PAVEMENT MARKING	SQFT	550	4.58	2,519.00	4.00
21	850111	PAVEMENT MARKER (RETROREFLECTIVE)	EA	210	3.10	651.00	3.00
22	566011	ROADSIDE SIGN - ONE POST	EA	2	290.00	580.00	350.00
23	150742	REMOVE (AND SALVAGE) EXISTING SIGN (AND POST)	EA	11	68.00	748.00	50.00
24	015602	FUNDING AWARENESS SIGN	EA	2	710.00	1,420.00	1,000.00
25	010602	MISCELLANEOUS WORK (AS DIRECTED)	FA	1	30,000.00	30,000.00	30,000.00
26	019901	DE-MOBILIZATION	LS	1	10,000.00	10,000.00	10,000.00
<b>PROJECT TOTAL, ITEMS 1 - 26</b>						<b>415,518.00</b>	<b>420,225.00</b>



**Riverside County Transportation Department  
Summary of Bids**

**PROJECT: Serfas Club Drive and Monterey Peninsula Drive  
Traffic Signal and Lighting Project  
In the Community of Coronita**

Advertised: June 16, 2015 (Agenda Item: 3-55)  
Addenda: 1 (6/23/15)

Bids Open: 2 pm Date: Wednesday, July 8, 2015

PROJECT No. C5-0073

BASE BID SCHEDULE		4			5			
ITEM NO.	ITEM CODE	CONTRACT ITEM	UNITS	QUANTITY	BID UNIT PRICE	BID ESTIMATE	BID UNIT PRICE	BID ESTIMATE
1	130200	PREPARE WATER POLLUTION CONTROL PROGRAM	LS	1	1,000.00	1,000.00	500.00	500.00
2	120100	TRAFFIC CONTROL SYSTEM	LS	1	13,600.00	13,600.00	17,500.00	17,500.00
3	170101	DEVELOP WATER SUPPLY	LS	1	1,600.00	1,600.00	1,500.00	1,500.00
4	066100	DUST CONTROL	LS	1	3,900.00	3,900.00	5,000.00	5,000.00
5	160101	CLEARING AND GRUBBING	LS	1	10,600.00	10,600.00	10,000.00	10,000.00
6	190101	ROADWAY EXCAVATION	CY	50	200.00	10,000.00	180.00	9,000.00
7	153103	COLD PLANE ASPHALT CONCRETE PAVEMENT	SQYD	675	19.60	13,230.00	17.50	11,812.50
8	390130	HOT MIX ASPHALT	TON	150	196.00	29,400.00	175.00	26,250.00
9	017316	MINOR CONCRETE (CURB RAMP) (CRS 403 - CASE B)	EA	4	5,800.00	23,200.00	5,200.00	20,800.00
10	017317	MINOR CONCRETE (CROSS-GUTTER AND SPANDREL)	SQFT	1,700	18.50	31,450.00	16.50	28,050.00
11	000001	ITEM DELETED BY ADDENDUM						
12	731521	MINOR CONCRETE (SIDEWALK)	SQFT	100	9.00	900.00	8.00	800.00
13	017305	MINOR CONCRETE (CURB AND GUTTER) (CRS 201)	LF	40	34.00	1,360.00	30.00	1,200.00
14	513553	RETAINING WALL (MASONRY WALL) [PER CONSTRUCTION NOTE 9]	LF	50	185.00	9,250.00	165.00	8,250.00
14.A	513553	RETAINING WALL (MASONRY WALL) [PER CONSTRUCTION NOTE 13]	LF	30	218.00	6,540.00	195.00	5,850.00
14.B	839514	HAND RAILING [PER APWA STD 606-3, TYPE B]	LF	60	175.00	10,500.00	155.00	9,300.00
15	000003	REPLACE DAMAGED PLANTS/SOD	LS	1	3,400.00	3,400.00	3,000.00	3,000.00
16	860201	SIGNAL AND LIGHTING	LS	1	199,632.00	199,632.00	216,057.50	216,057.50
17	150710	REMOVE TRAFFIC STRIPE	LF	300	1.12	336.00	0.60	180.00
18	150715	REMOVE THERMOPLASTIC PAVEMENT MARKING	SQFT	600	3.08	1,848.00	2.90	1,740.00
19	840656	PAINT TRAFFIC STRIPE (2-COAT)	LF	8,300	0.44	3,652.00	0.25	2,075.00
20	840515	THERMOPLASTIC PAVEMENT MARKING	SQFT	550	4.40	2,420.00	4.30	2,365.00
21	850111	PAVEMENT MARKER (RETROREFLECTIVE)	EA	210	3.30	693.00	2.90	609.00
22	566011	ROADSIDE SIGN - ONE POST	EA	2	385.00	770.00	272.00	544.00
23	150742	REMOVE (AND SALVAGE) EXISTING SIGN (AND POST)	EA	11	110.00	1,210.00	63.00	693.00
24	015602	FUNDING AWARENESS SIGN	EA	2	750.00	1,500.00	655.00	1,310.00
25	010602	MISCELLANEOUS WORK (AS DIRECTED)	FA	1	30,000.00	30,000.00	30,000.00	30,000.00
26	019901	DE-MOBILIZATION	LS	1	10,000.00	10,000.00	10,000.00	10,000.00
<b>PROJECT TOTAL, ITEMS 1 - 26</b>						<b>421,991.00</b>		<b>424,386.00</b>

**Riverside County Transportation Department  
Summary of Bids**

**PROJECT: Serfas Club Drive and Monterey Peninsula Drive  
Traffic Signal and Lighting Project  
In the Community of Coronita**

Advertised: June 16, 2015 (Agenda Item: 3-55)  
Addenda: 1 (6/23/15)  
Bids Open: 2 pm Date: Wednesday, July 8, 2015

PROJECT No. C5-0073

BASE BID SCHEDULE		CONTRACT ITEM		6		7	
ITEM NO.	ITEM CODE	UNITS	QUANTITY	BID UNIT PRICE	BID ESTIMATE	BID UNIT PRICE	BID ESTIMATE
1	130200	LS	1	787.00	787.00	5,000.00	5,000.00
2	120100	LS	1	8,721.00	8,721.00	25,000.00	25,000.00
3	170101	LS	1	703.00	703.00	2,000.00	2,000.00
4	066100	LS	1	3,254.00	3,254.00	5,000.00	5,000.00
5	160101	LS	1	2,864.00	2,864.00	15,000.00	15,000.00
6	190101	CY	50	321.00	16,050.00	210.00	10,500.00
7	153103	SQYD	675	14.00	9,450.00	16.00	10,800.00
8	390130	TON	150	289.00	43,350.00	225.00	33,750.00
9	017316	EA	4	4,108.00	16,432.00	6,000.00	24,000.00
10	017317	SQFT	1,700	11.44	19,447.50	17.00	28,900.00
11	000001	---	---	---	---	---	---
12	731521	SQFT	100	24.00	2,400.00	13.00	1,300.00
13	017305	LF	40	46.00	1,840.00	85.00	3,400.00
14	513553	LF	50	269.00	13,450.00	135.00	6,750.00
14.A	513553	LF	30	336.00	10,080.00	280.00	8,400.00
14.B	839514	LF	60	56.00	3,360.00	250.00	15,000.00
15	000003	LS	1	3,905.00	3,905.00	3,500.00	3,500.00
16	860201	LS	1	227,559.00	227,559.00	190,160.00	190,160.00
17	150710	LF	300	1.30	390.49	1.30	390.00
18	150715	SQFT	600	3.58	2,147.67	3.50	2,100.00
19	840656	LF	8,300	0.52	4,321.00	0.50	4,150.00
20	840515	SQFT	550	5.21	2,863.56	5.20	2,860.00
21	850111	EA	210	3.90	820.02	3.80	798.00
22	566011	EA	2	456.00	912.00	450.00	900.00
23	150742	EA	11	130.00	1,430.00	130.00	1,430.00
24	015602	EA	2	914.00	1,828.00	1,400.00	2,800.00
25	010602	FA	1	30,000.00	30,000.00	30,000.00	30,000.00
26	019901	LS	1	10,000.00	10,000.00	10,000.00	10,000.00
<b>PROJECT TOTAL, ITEMS 1 - 26</b>					<b>438,365.24</b>		<b>443,888.00</b>

**Riverside County Transportation Department  
Summary of Bids**

**PROJECT: Serfas Club Drive and Monterey Peninsula Drive  
Traffic Signal and Lighting Project  
In the Community of Coronita**

Advised: June 16, 2015 (Agenda Item: 3-55)  
Addenda: 1 (6/23/15)  
Bids Open: 2 pm Date: Wednesday, July 8, 2015

**PROJECT No. C5-0073**

BASE BID SCHEDULE		CONTRACT ITEM		8		Calif. Professional Eng., Inc. La Puente, CA 91748	
ITEM NO.	ITEM CODE	UNITS	QUANTITY	BID UNIT PRICE	BID ESTIMATE		
1	130200	LS	1	1,500.00	1,500.00		
2	120100	LS	1	21,165.00	21,165.00		
3	170101	LS	1	1,200.00	1,200.00		
4	066100	LS	1	800.00	800.00		
5	160101	LS	1	55,000.00	55,000.00		
6	190101	CY	50	165.00	8,250.00		
7	153103	SQYD	675	11.00	7,425.00		
8	390130	TON	150	181.50	27,225.00		
9	017316	EA	4	3,520.00	14,080.00		
10	017317	SQFT	1,700	11.55	19,635.00		
11	000001	----	----	----	----		
12	731521	SQFT	100	11.00	1,100.00		
13	017305	LF	40	77.00	3,080.00		
14	513553	LF	50	759.00	37,950.00		
14.A	513553	LF	30	132.00	3,960.00		
14.B	839514	LF	60	100.00	6,000.00		
15	000003	LS	1	5,000.00	5,000.00		
16	860201	LS	1	188,000.00	188,000.00		
17	150710	LF	300	0.69	207.00		
18	150715	SQFT	600	3.34	2,001.00		
19	840656	LF	8,300	0.29	2,386.25		
20	840515	SQFT	550	4.95	2,719.75		
21	850111	EA	210	3.34	700.35		
22	566011	EA	2	312.80	625.60		
23	150742	EA	11	72.45	796.95		
24	015602	EA	2	800.00	1,600.00		
25	010602	FA	1	30,000.00	30,000.00		
26	019901	LS	1	10,000.00	10,000.00		
<b>PROJECT TOTAL, ITEMS 1 - 26</b>					<b>452,406.90</b>		



Juan C. Perez, P.E., T.E.  
 Director of Transportation and Land  
 Management

# COUNTY OF RIVERSIDE

## TRANSPORTATION AND LAND MANAGEMENT AGENCY



Patricia Romo, P.E.  
 Assistant Director of Transportation

### Transportation Department

#### ADDENDUM NUMBER 1

Dated June 23, 2015

to the  
 Specifications and Contract Documents  
 for the construction of

**Serfas Club Drive and Monterey Peninsula Drive  
 Traffic Signal and Lighting Project  
 In the Community of Coronita  
 Project No. C5-0073**

**Bids Due: Wednesday, July 8, 2015; 2:00 p.m.**  
 14<sup>th</sup> Street Transportation Annex  
 3525 14<sup>th</sup> Street; Riverside, CA 92501  
 (951) 955-6780

This Addendum is issued pursuant to the Instructions to Bidders, Item No. 8, of the Contract Documents for the reference project. This Addendum is issued as a supplement to the specification and special provisions for the referenced project. The revisions to the specifications shall become a part of the Contract Documents, and each bidder shall acknowledge receipt thereof on the Bid (Proposal). Bidders are directed to sign this addendum as acknowledged, and attach the signed addendum to the contractor's submitted proposal.

Note: During the advertisement period of this project, this document and attachments (if any) are available upon request at the office of the Transportation Department, and are available as a free download at the Transportation Department's website:

<http://rctlma.org/trans/Contractors-Corner/Notices-Inviting-Bids>

#### MODIFICATIONS / CLARIFICATIONS TO SPECIAL PROVISIONS:

**Item 1: Revised Proposal.** Refer to "Proposal" page B2. Delete "Proposal" (page B2) and replace it with "Revised Proposal" attached herewith as **Attachment "A"**. The following changes have been made to the Proposal:

- a. The following bid item is deleted:  
 Item 11, "MINOR CONCRETE [RETAINING CURB]"
- b. The description and estimated quantity are revised for the following bid item:  
 Item 14, "RETAINING WALL (MASONRY WALL) [PER CONSTRUCTION NOTE 9]"
- c. The following bid items are added:  
 Item 14.A, "RETAINING WALL (MASONRY WALL) [PER CONSTRUCTION NOTE 13]"  
 Item 14.B, "HANDRAILING [PER APWA STD 606-3 TYPE B]"

**Item 2: Clarification of Retaining Wall.** Refer to Section 51, Concrete Structures, of the Special Provisions for the construction of RETAINING WALL (MASONRY WALL) [PER CONSTRUCTION NOTE 9].

**Item 3: Retaining Wall Special Provision.** The following Special Provisions are added and made part hereof:

**RETAINING WALL [PER CONSTRUCTION NOTE 13]**

Retaining wall shall be constructed per County of Riverside Building and Safety Department retaining wall standard and the detail shown on the plans, and shall conform to the applicable portions of Sections 51, 52, 55, 75 and 90 of the Standard Specifications and these Special Provisions, and as directed by the Engineer.

Removed materials of any kind in result of retaining walls construction shall be disposed of out of road Right of Way as specified elsewhere in these Special Provisions.

Payment

The contract bid price paid per linear foot for "Retaining Wall (Masonry Wall) [Per Construction Note 13]" shall include full compensation for furnishing all labor, tools, materials and equipment and doing all the work involved, including structure excavation and backfill, furnishing and placing reinforcement bars, and no additional compensation will be allowed therefor.

**Item 4: Hand Railing Special Provision.** The following Special Provisions are added and made part hereof:

**METAL HAND RAILING**

Metal hand railing shall conform to the APWA (Greenbook) Standard Plan 606-3, Type B, these Special Provisions, the details on the plans, the applicable portions of Sections 55 and 75 of the Standard Specifications, and as directed by the Engineer.

Metal railing shall consist of metal elements mounted on concrete members as shown on the plans.

Steel railing material shall be welded or seamless steel pipe.

Materials and construction for the railings shall conform to the following requirements:

Material	ASTM Designation
Tubular steel rails, and tubular hand railing	A 500, Grade B
Steel posts, rolled bars and plate washers	A 36/A 36M
Steel sleeves for tubular rails	A 36/A 36M
High strength bolts	A325 or A 325M or A 449
High strength threaded rods	A 449
Nuts and washers for high strength bolts and rods	A 325 or A 325M

The edges and center of the rail element shall contact each post or block. Rail element joints shall be lapped not less than 12-1/2 inches and bolted.

The ends of each length of railing shall be fitted with terminal sections.

Workmanship shall be equivalent to commercial practice and all edges, bolt holes, and surfaces shall be free of torn metal, burrs, sharp edges, and protrusions.

Bolts shall have shoulders of such shape that will prevent them from turning.

Unless otherwise specified, the rail elements, terminal sections, bolts, nuts, and other fittings shall be galvanized.

#### Installation

The railing shall be erected in accordance with the Plans on anchor bolts, or in holes formed by inserts provided in the concrete railing base to receive the railing posts. Sheet metal inserts shall be removed before the erection of the railing.

No railing shall be erected on the structure until the wall to which it is to be attached is completed and all falsework supporting the system is released.

The railing shall be carefully erected, true to line and grade. Posts and balusters shall be vertical with the deviation from the vertical for the full height of the panel not exceeding 1/8 inch.

After erecting the railing, any abrasions or exposed steel shall be repaired by Hot-Dip process or Metalizing Process as approved by the Resident Engineer.

#### Payment

The contract price paid per linear foot for Hand Railing shall include full compensation for furnishing all labor, materials, tools, equipment, and incidentals, and for doing all the work involved in constructing the railing, complete in place, including, but not limited to, any work and materials necessary to secure railing on top of retaining wall, excavation, backfill and disposal of surplus material, concrete and reinforcing steel, as shown on the plans, as specified in these special provisions and as directed by the Resident Engineer.

**Item 5: Retaining Wall and Hand Railing Reference Drawings.** County of Riverside Building and Safety Department Retaining Wall Standard, and APWA (Greenbook) Hand Railing Standard Plan 606-3 are provided and attached herewith as **Attachment "C"** for reference.

### MODIFICATIONS / CLARIFICATIONS TO THE PLANS

**Item 6: Plan sheet revisions.** The following Plan sheets are revised or added by **Attachment "B"** and made a part hereof:

a. Delete and replace the following two (2) plan sheets:

1. Plan sheet 2 of 5, L-1, Layout
2. Plan sheet 3 of 5, C-2, Construction Details

**Note:** All revised plan sheets are posted on the County website and are available for download during the advertisement period.

<http://rctlma.org/trans/Contractors-Corner/Notices-Inviting-Bids>

This addendum has been prepared under the direction of the following registered Civil Engineer(s):

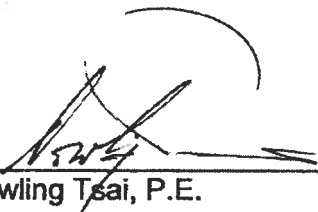
  
\_\_\_\_\_  
Dowling Tsai, P.E.

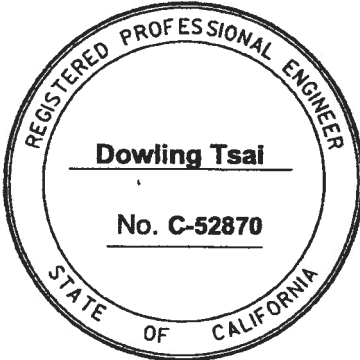

**Concurrence:**

 6/22/15  
\_\_\_\_\_  
Khalid Nasim, P.E.  
Engineering Division Manager

**Acknowledged:** \_\_\_\_\_ **Date:** \_\_\_\_\_  
(Contractor)

JRJ:jrj:rr

Note: Refer to Section 8, "Addenda" (page A4). Submission of all addendum pages and non-bidding document attachments of addendum are not necessary for Bid submittal. Submittal of **only this** acknowledgement page is adequate for Bid reception. Bidders are reminded to list addendum number(s) received on the first page (B1) of the Bid form (Proposal).

## **ATTACHMENTS**

**A – Revised Proposal**

**B – Revised Plan Sheets (2)**

**C – Retaining Wall and Hand Railing Reference Drawings**



**Serfas Club Drive and Monterey Peninsula Drive  
Traffic Signal and Lighting Project  
In the Community of Coronita  
Project No. C5-0073**

ISSUED BY ADDENDUM No. 1  
ATTACHMENT "A"

**REVISED PROPOSAL**

ITEM No.	ITEM CODE	ITEM	UNIT	ESTIMATED QUANTITY	ITEM PRICE (IN FIGURES)	TOTAL (IN FIGURES)
1	130200	PREPARE WATER POLLUTION CONTROL PROGRAM	LS	1		
2	120100	TRAFFIC CONTROL SYSTEM	LS	1		
3	170101	DEVELOP WATER SUPPLY	LS	1		
4	066100	DUST CONTROL	LS	1		
5	160101	CLEARING AND GRUBBING	LS	1		
6	190101	ROADWAY EXCAVATION	CY	50		
7	153103	COLD PLANE ASPHALT CONCRETE PAVEMENT	SQYD	675		
8	390130	HOT MIX ASPHALT	TON	150		
9	017316	MINOR CONCRETE (CURB RAMP) (CRS 403 - CASE B)	EA	4		
10	017317	MINOR CONCRETE (CROSS-GUTTER AND SPANDREL)	SQFT	1,700		
11	000001	ITEM DELETED BY ADDENDUM	----	----	----	----
12	731521	MINOR CONCRETE (SIDEWALK)	SQFT	100		
13	017305	MINOR CONCRETE (CURB AND GUTTER) (CRS 201)	LF	40		
14	513553	RETAINING WALL (MASONRY WALL) [PER CONSTRUCTION NOTE 9]	LF	50		
14.A	513553	RETAINING WALL (MASONRY WALL) [PER CONSTRUCTION NOTE 13]	LF	30		
14.B	839514	HAND RAILING [PER APWA STD 606-3, TYPE B]	LF	60		
15	000003	REPLACE DAMAGED PLANTS/SOD	LS	1		
16	860201	SIGNAL AND LIGHTING	LS	1		
17	150710	REMOVE TRAFFIC STRIPE	LF	300		
18	150715	REMOVE THERMOPLASTIC PAVEMENT MARKING	SQFT	600		
19	840656	PAINT TRAFFIC STRIPE (2-COAT)	LF	8,300		
20	840515	THERMOPLASTIC PAVEMENT MARKING	SQFT	550		
21	850111	PAVEMENT MARKER (RETROREFLECTIVE)	EA	210		
22	566011	ROADSIDE SIGN - ONE POST	EA	2		
23	150742	REMOVE (AND SALVAGE) EXISTING SIGN (AND POST)	EA	11		
24	015602	FUNDING AWARENESS SIGN	EA	2		
25	010602	MISCELLANEOUS WORK (AS DIRECTED)	FA	1	30,000.00	30,000.00
26	019901	DE-MOBILIZATION	LS	1	10,000.00	10,000.00

PROJECT TOTAL: \_\_\_\_\_ \$

ITEMS 1-26 "WORDS"



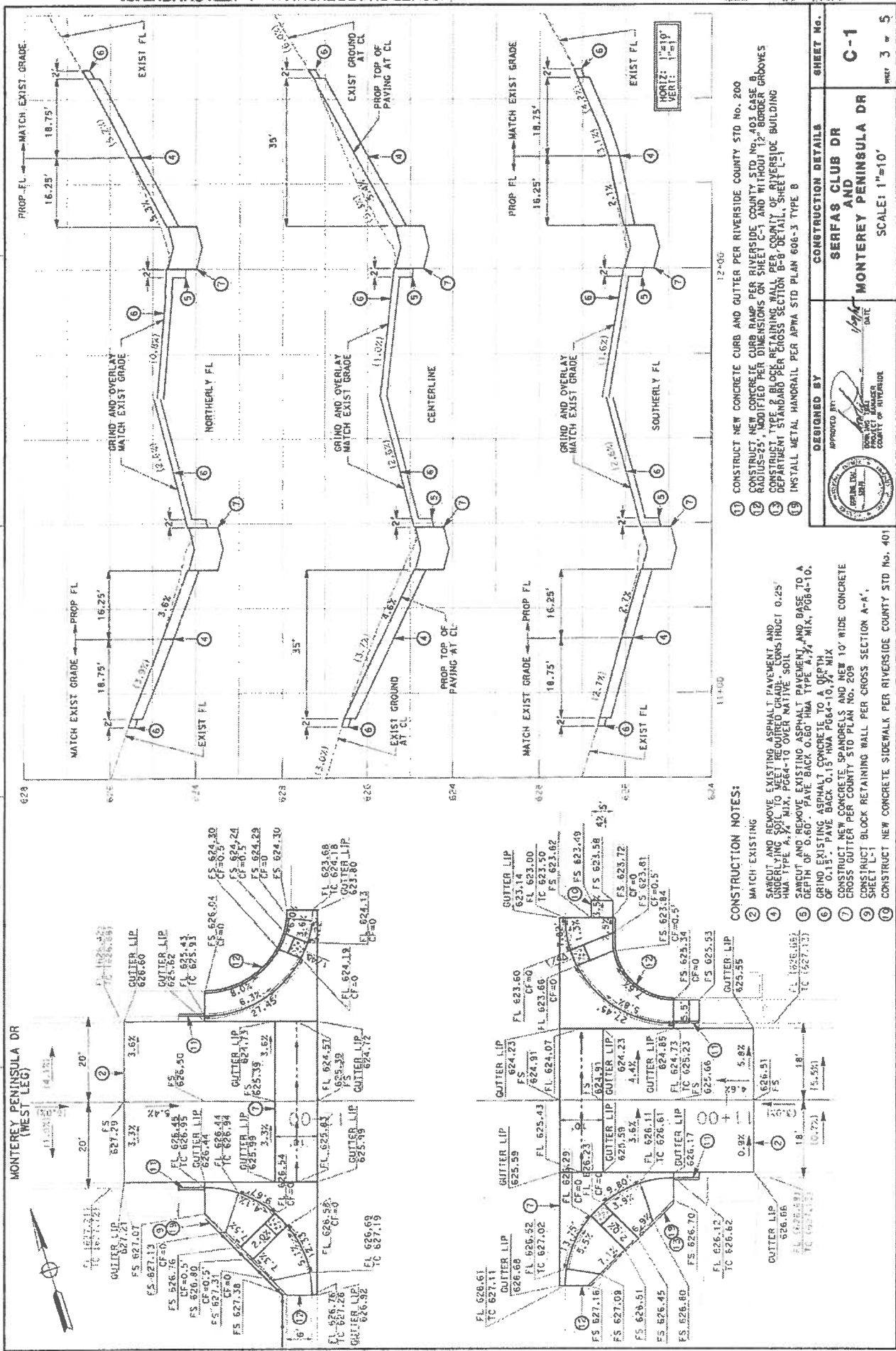

### TYPE 1: 6" TOE

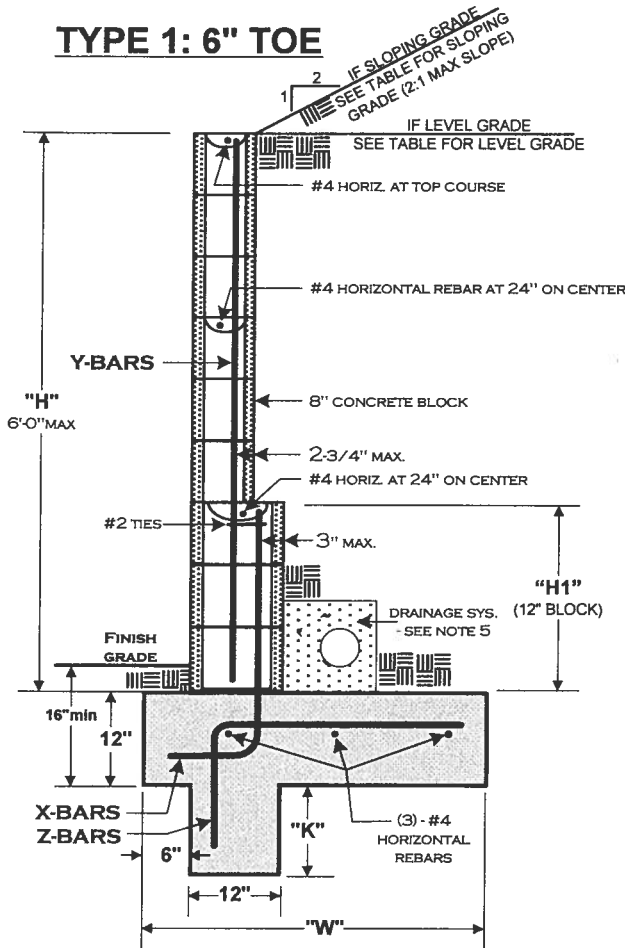

### TYPE 2: 6" HEEL

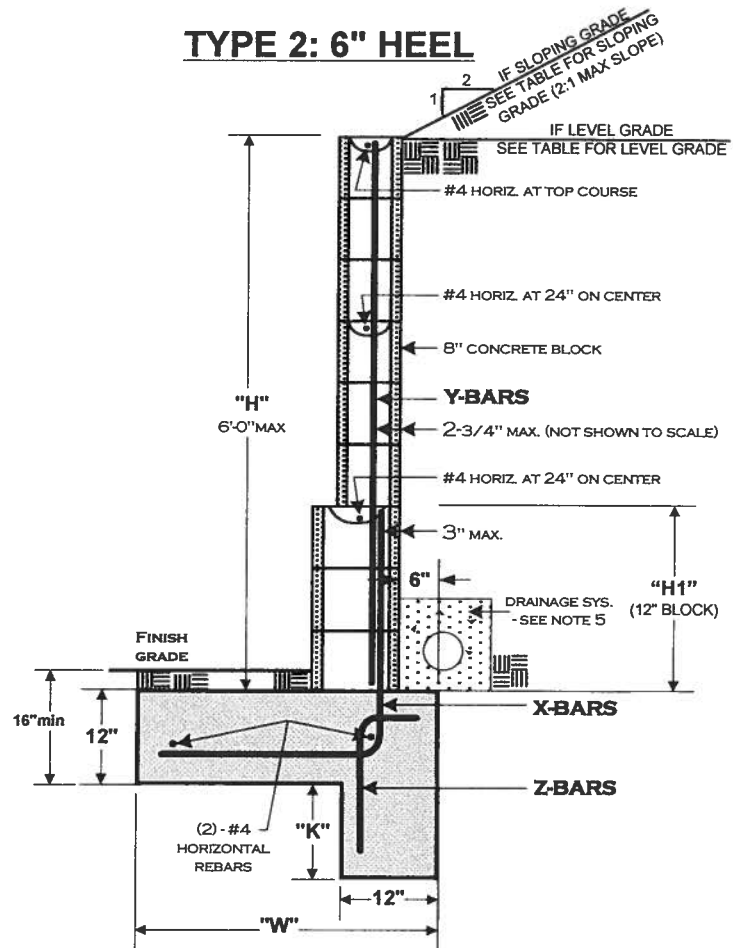

TYPE 1: 6" TOE							
GRADE CONDITION	"H" (WALL HEIGHT)	"H1" (12" BLOCK)	"W" (FOOTING WIDTH)	X BARS	Y BARS	ZBARS	"K" (KEY DEPTH)
SLOPING GRADE AT TOP OF WALL (2:1 MAX)	5'-1" to 6'-0"	24"	69"	#4 @ 16"	#4 @ 32"	#4 @ 11"	30"
	4'-1" to 5'-0"	N/R	48"	#4 @ 16"	#4 @ 16"	#4 @ 12"	25"
	3'-1" to 4'-0"	N/R	30"	#4 @ 32"	#4 @ 32"	#4 @ 32"	16"
	Up to 3'-0"	N/R	18"	#4 @ 32"	#4 @ 32"	#4 @ 32"	8"
LEVEL GRADE AT TOP OF WALL	5'-1" to 6'-0"	24"	45"	#4 @ 24"	#4 @ 32"	#4 @ 24"	8"
	4'-1" to 5'-0"	N/R	36"	#4 @ 24"	#4 @ 24"	#4 @ 24"	7"
	3'-1" to 4'-0"	N/R	24"	#4 @ 32"	#4 @ 32"	#4 @ 32"	5"
	Up to 3'-0"	N/R	21"	#4 @ 32"	#4 @ 32"	#4 @ 32"	N/R

TYPE 2: 6" HEEL							
GRADE CONDITION	"H" (WALL HEIGHT)	"H1" (12" BLOCK)	"W" (FOOTING WIDTH)	X BARS	Y BARS	ZBARS	"K" (KEY DEPTH)
SLOPING GRADE AT TOP OF WALL (2:1 MAX)	5'-1" to 6'-0"	24"	39"	#4 @ 16"	#4 @ 32"	#4 @ 12"	28"
	4'-1" to 5'-0"	N/R	29"	#4 @ 16"	#4 @ 16"	#4 @ 12"	22"
	3'-1" to 4'-0"	N/R	24"	#4 @ 32"	#4 @ 32"	#4 @ 32"	15"
	Up to 3'-0"	N/R	18"	#4 @ 32"	#4 @ 32"	#4 @ 32"	8"
LEVEL GRADE AT TOP OF WALL	5'-1" to 6'-0"	24"	33"	#4 @ 24"	#4 @ 32"	#4 @ 24"	18"
	4'-1" to 5'-0"	N/R	26"	#4 @ 24"	#4 @ 24"	#4 @ 24"	13"
	3'-1" to 4'-0"	N/R	20"	#4 @ 32"	#4 @ 32"	#4 @ 32"	7"
	Up to 3'-0"	N/R	20"	#4 @ 32"	#4 @ 32"	#4 @ 32"	N/R

N/R = NOT REQUIRED

\*SEE PAGE 2 FOR ADDITIONAL INFORMATION\*

#### DISCLAIMER:

ALTERNATE RETAINING WALL DESIGNS MAY BE POSSIBLE WHEN PROVIDED WITH AN ENGINEERED ANALYSIS. USE OF THIS STANDARD DESIGN IS AT THE USER'S RISK AND CARRIES NO IMPLIED OR INFERRED GUARANTEE AGAINST FAILURE OR DEFECTS.

<b>WESTERN RIVERSIDE COUNTY CODE UNIFORMITY PROGRAM</b>			
		<b>COUNTY OF RIVERSIDE BUILDING DEPARTMENT</b>	
<b>RETAINING WALLS</b>			
(951) 955-1800		4080 LEMON ST, 2ND FL * P.O. BOX 1629 * RIVERSIDE, CA 92501	
FAX (951) 955-1806		2/24/2014	RCLMNRWALLFNLVSD
		PAGE 1 OF 2	

**GENERAL NOTES:**

- 1) ALL WORK SHALL CONFORM TO THE ADOPTED CODES AND ZONING REGULATIONS.
- 2) CONCRETE BLOCK MASONRY SHALL COMPLY WITH THE FOLLOWING:
  - A. CONCRETE MASONRY SHALL CONFORM TO ASTM C-90, GRADE - N.
  - B. MORTAR: TYPE M OR S.
  - C. GROUT ALL CELLS W/2000 PSI PORTLAND CEMENT GROUT.
- 3) THE ULTIMATE COMPRESSIVE STRENGTH REQUIRED FOR FOUNDATION CONCRETE SHALL BE 2500 PSI.
- 4) ALL REINFORCING STEEL SHALL BE INTERMEDIATE GRADE ASTM A615-40 AND OVERLAP SPLICES SHALL BE 40 BAR DIAMETERS MINIMUM. ALL REBAR HOOKS SHALL BE A MINIMUM OF 12 TIMES THE REBAR DIAMETER (12bd) IN LENGTH.
- 5) PROVIDE RETAINING WALL DRAINAGE SYSTEM AS FOLLOWS:  
 PROVIDE 1CF/FT OF CLEAN COARSE GRAVEL WITH 4" DIAMETER PERFORATED PVC DRAINAGE PIPE WITH 1% GRADIENT TO DRAIN - OR OMIT HEAD JOINTS IN FIRST COURSE.
- 6) OPTIONAL: INSTALLATION OF A MOISTURE BARRIER ON THE FILL SIDE OF THE WALL WILL HELP TO PREVENT MOISTURE FROM PENETRATING THE VISIBLE SIDE OF THE WALL, RESULTING IN DISCOLORATION.
- 7) THIS RETAINING WALL STANDARD IS **NOT** DESIGNED TO SUPPORT SURCHARGE LOADS FROM MOTOR VEHICLES OR OTHER STRUCTURES.
- 8) CLEANOUTS SHALL BE PROVIDED FOR ALL GROUT POURS OVER 5 FEET IN HEIGHT. WHERE REQUIRED, CLEANOUTS SHALL BE PROVIDED IN THE BOTTOM COURSE AT EVERY VERTICAL BAR AND SHALL BE SEALED AFTER INSPECTION AND BEFORE GROUTING.

**REQUIRED INSPECTIONS:**

- 1) **FOOTING:**  
 EXCAVATION TRENCH CLEAN WITH STEEL IN PLACE AND SUPPORTED 3" ABOVE AND AWAY FROM THE SURROUNDING EARTH/DIRT.
- 2) **REBAR/PRE-GROUT AND DRAINAGE SYSTEM:**  
 BOND BEAM REBAR AND VERTICAL REBAR IN PLACE - INSPECTION PRIOR TO PLACING GROUT. DRAINAGE SYSTEM COMPLETE.
- 3) **FINAL:**  
 AFTER GROUT IS PLACED AND BACKFILL COMPLETED - PRIOR TO ANY DECORATIVE CAP PLACEMENT.

**SETBACK FROM TOP OF SLOPE:**

ALL FOOTINGS ADJACENT TO SLOPES TO BE AT LEAST 5' TO DAYLIGHT AS SHOWN BELOW.

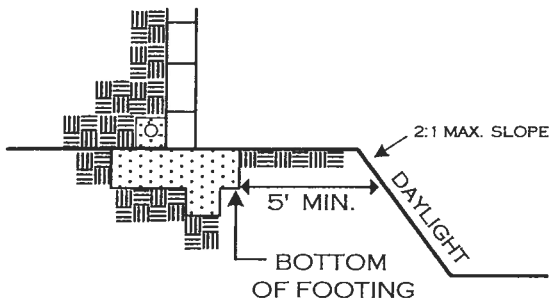

**DESIGN PARAMETERS:**

ACTIVE SOIL PRESSURE (PSF)	= 30
LEVEL BACKFILL	= 43
SLOPING (2:1 MAX)	= 150
PASSIVE SOIL BEARING (PSF)	= 0.25
COEFFICIENT OF FRICTION	= 1500
ALLOWABLE SOIL BEARING PRESSURE (PSF)	= 1500
(NO INCREASES TAKEN FOR DEPTH OR WIDTH OF FOOTING)	

**DISCLAIMER:**

ALTERNATE RETAINING WALL DESIGNS MAY BE POSSIBLE WHEN PROVIDED WITH AN ENGINEERED ANALYSIS. USE OF THIS STANDARD DESIGN IS AT THE USER'S RISK AND CARRIES NO IMPLIED OR INFERRED GUARANTEE AGAINST FAILURE OR DEFECTS.

<b>WESTERN RIVERSIDE COUNTY CODE UNIFORMITY PROGRAM</b>			
		<b>COUNTY OF RIVERSIDE</b>	
		<b>BUILDING DEPARTMENT</b>	
		<b>RETAINING WALLS</b>	
(951) 955-1800		4080 LEMON ST, 2ND FL * P.O. Box 1629 *	
FAX (951) 955-1806		RIVERSIDE, CA 92501	
	2/24/2014	RCLMNRETWALLFNLVSD	PAGE 2 OF 2

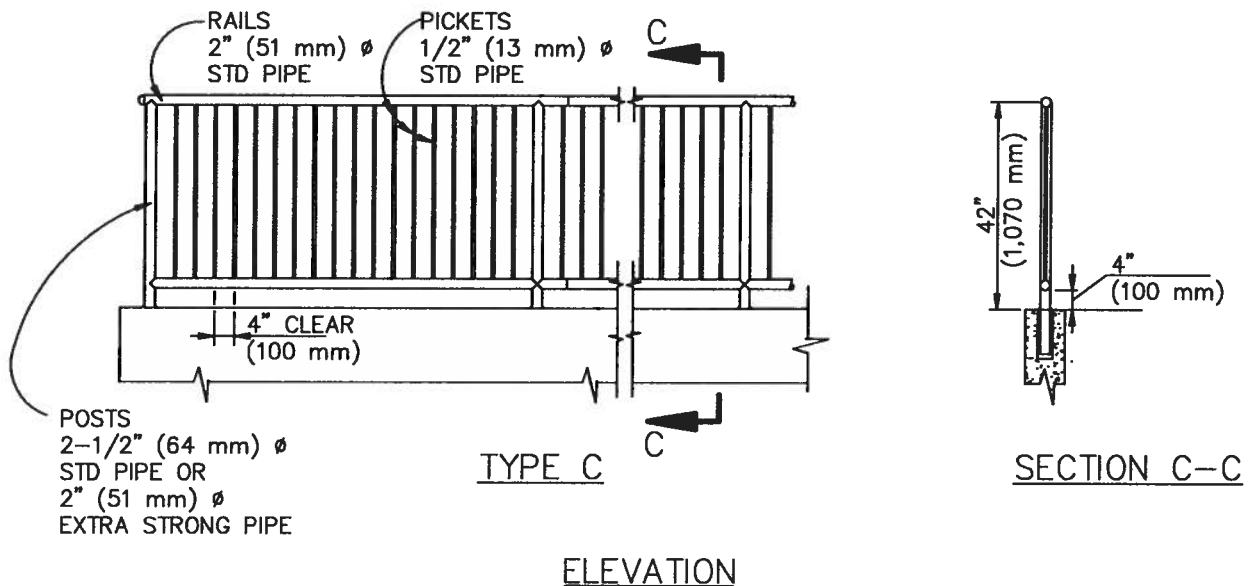
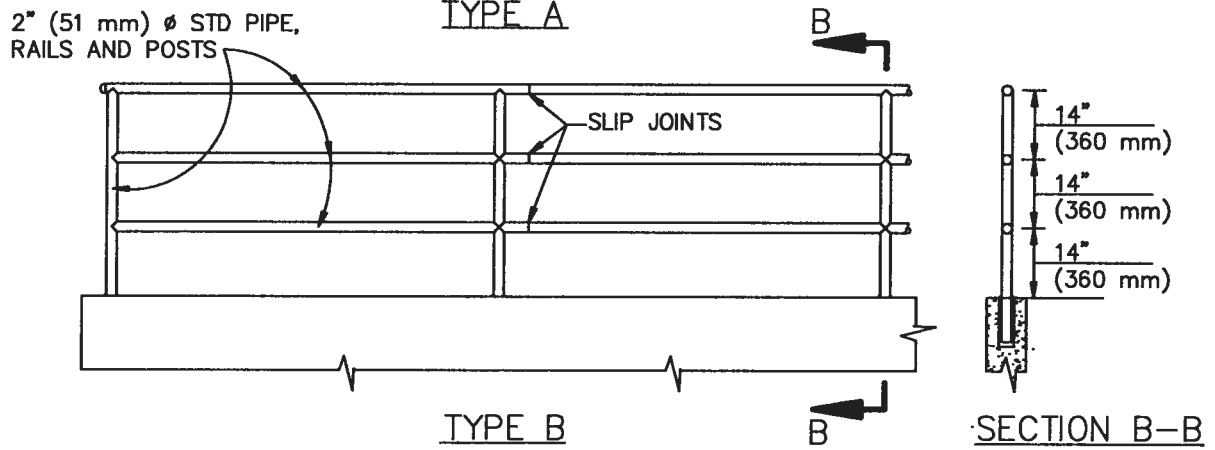
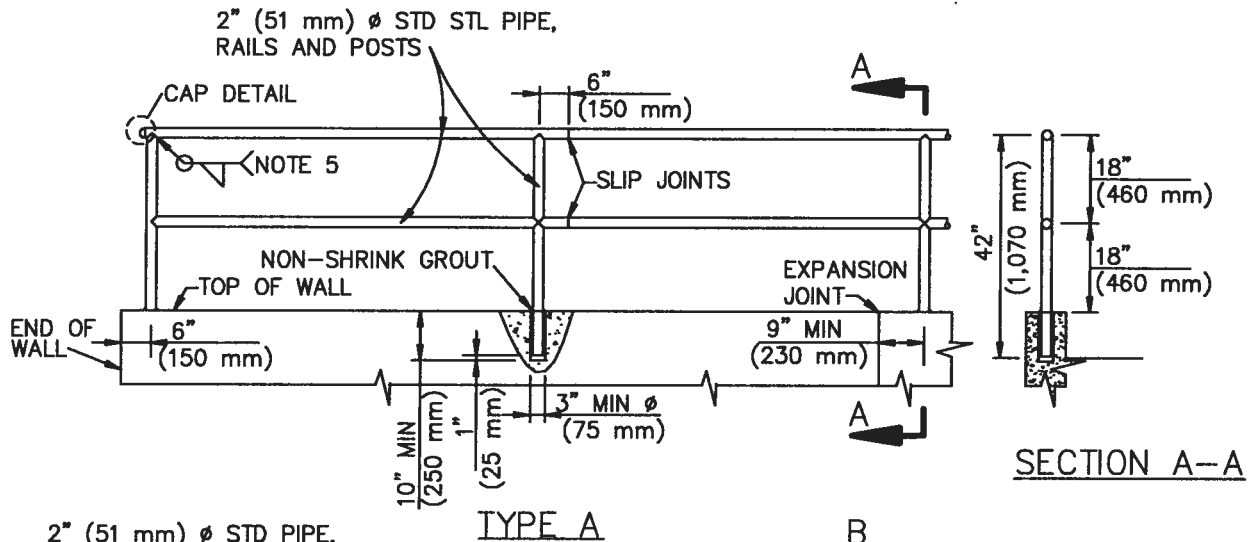

STANDARD PLANS FOR PUBLIC WORKS CONSTRUCTION

PROMULGATED BY THE  
PUBLIC WORKS STANDARDS INC.  
GREENBOOK COMMITTEE  
1993  
REV. 1996, 2005, 2009

METAL HAND RAILINGS

USE WITH STANDARD SPECIFICATIONS FOR PUBLIC WORKS CONSTRUCTION

STANDARD PLAN  
**606-3**  
SHEET 1 OF 3

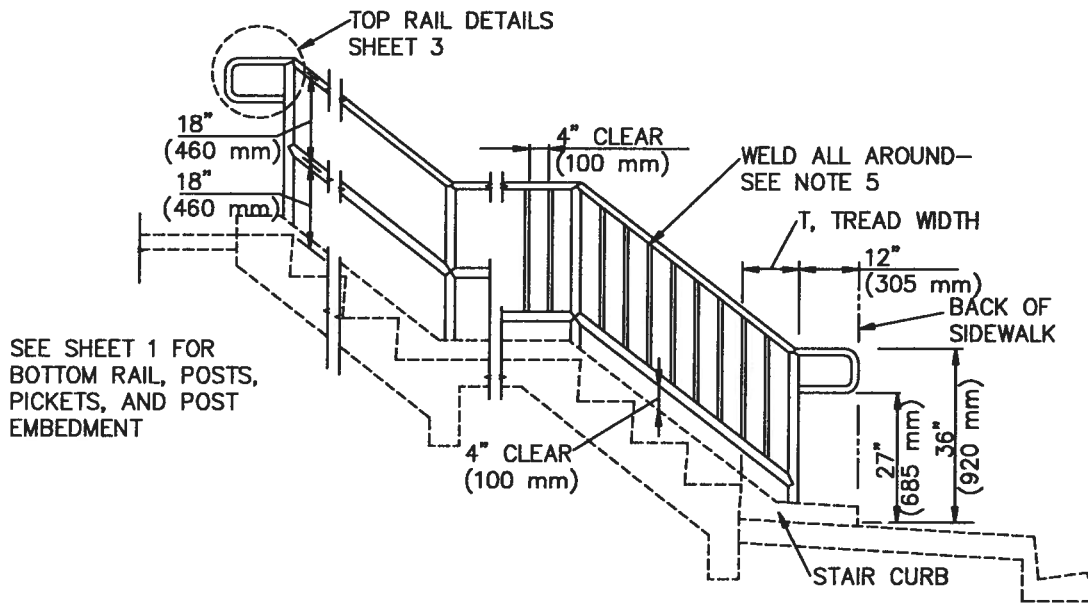

TYPE A                      TYPE C

HANDRAIL INSTALLATION ON STAIRWAYS

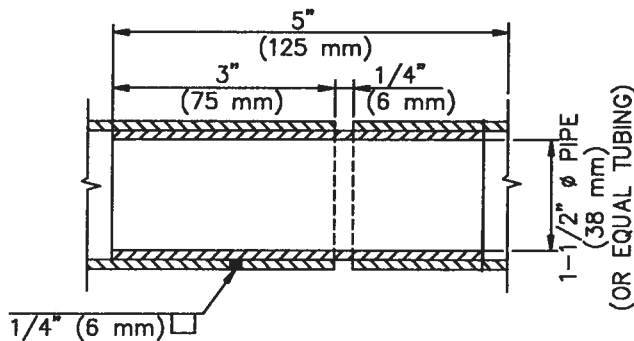

SLIP JOINT DETAIL

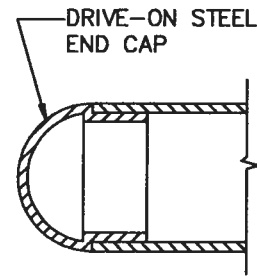

CAP DETAIL FOR RAIL END

NOTES:

1. USE TYPE C WHERE ADJACENT GRADE IS MORE THAN 2'-6" (760 mm) BELOW LANDING OR SIDEWALK FINISHED SURFACE.
2. RAILS, POSTS, AND PICKETS SHALL BE GALVANIZED STEEL PIPE.
3. PROVIDE SLIP JOINTS AT STAIRWAY EXPANSION JOINTS, 24' (7.3 m) MAXIMUM.
4. MAXIMUM SPACING OF POSTS SHALL BE 8'-0" (2.44 m) ON STRAIGHT ALIGNMENTS, AND 6'-0" (1.83 m) ON CURVED ALIGNMENTS WITH LESS THAN 30' (9.1 m) RADIUS. MAKE SPACING UNIFORM BETWEEN CHANGES IN ALIGNMENT.
5. WELDS SHALL BE SLOT OR FILLET WELDS EQUAL TO THICKNESS OF PIPE. WELD ALL JOINTS ALL AROUND.

STANDARD PLANS FOR PUBLIC WORKS CONSTRUCTION

STANDARD PLAN

**METAL HAND RAILINGS**

**606-3**

SHEET 2 OF 3

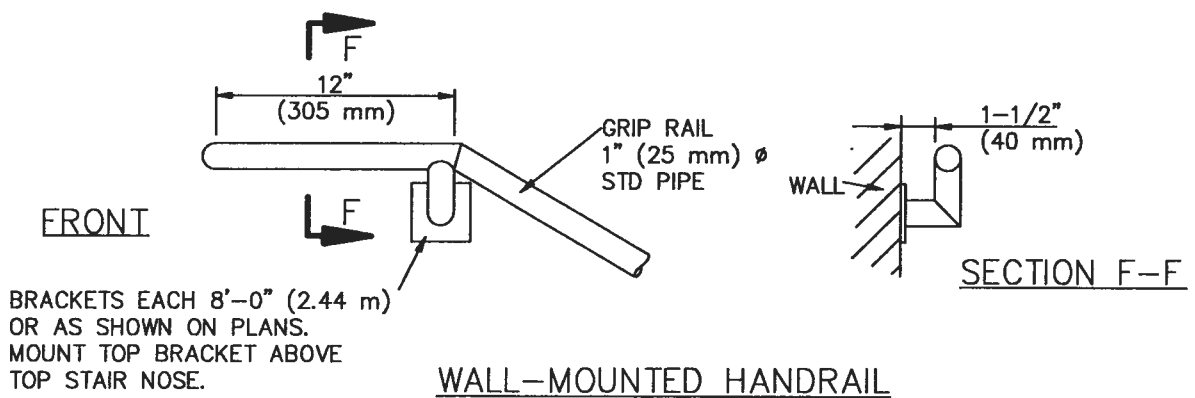
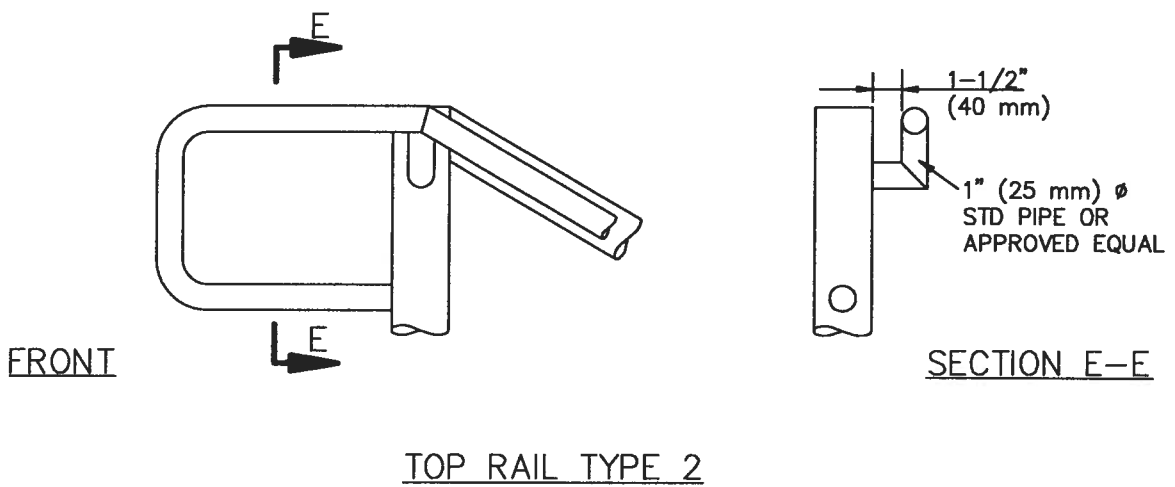
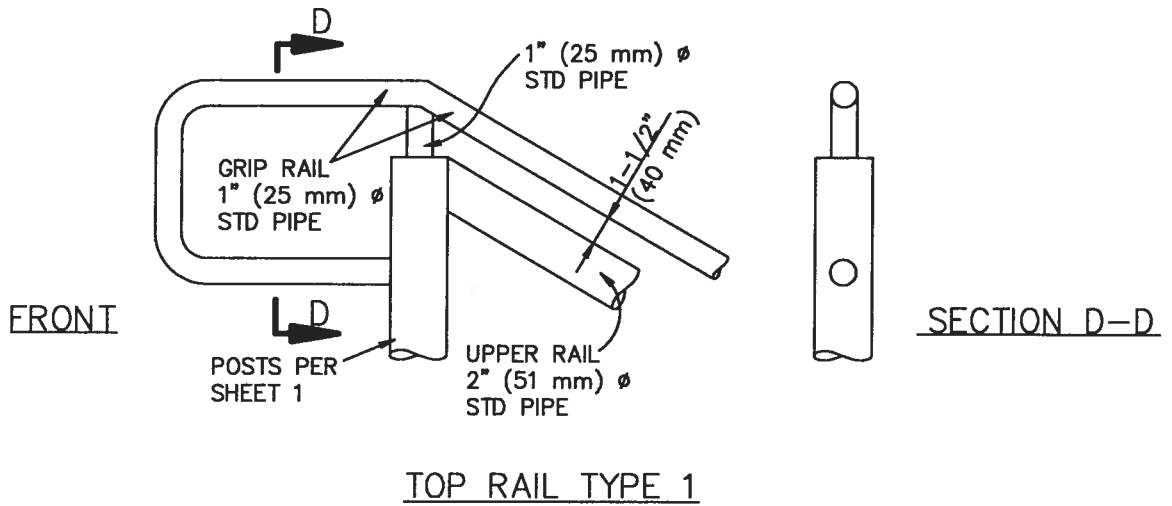

STANDARD PLANS FOR PUBLIC WORKS CONSTRUCTION

**METAL HAND RAILINGS**

STANDARD PLAN

**606-3**

SHEET 3 OF 3



## Contract

THIS CONTRACT is entered into at Riverside, California as of the date set forth below is between County of Riverside hereafter called "County" and DBX, Inc., hereafter called "Contractor".

### W I T N E S S E T H

#### Recitals:

1. Contractor has submitted to County his Contractor's Proposal for the construction of County Project, **Serfas Club Drive and Monterey Peninsula Drive, Traffic Signal and Lighting Project, In the Community of Coronita, Project No. C5-0073**, in strict accordance with the Contract Documents identified below and County has accepted said Proposal.
2. Contractor states that he has reexamined his Contractor's Proposal and found it to be correct, has ascertained that his subcontractors are properly licensed and possess the requisite skill and forces, has reexamined the site and Contract Documents and is of the opinion that he can presently do the work in accordance with the Contract Documents for the money set forth in his Proposal to be paid as provided in the Contract Documents.

#### Agreement:

It is agreed by the parties as follows:

##### 1. Contract Documents

The entire Contract consists of the following: (a) The Construction Contract, (b) The Notice to Bidders, (c) The Instruction to Bidders, (d) The Bid, (e) The Bid Bond, (f) The Payment Bond, (g) The Performance Bond, (h) The General Conditions, (i) The Special Provisions, (j) The Standard Specifications of the State of California Department of Transportation edition of **2010** as modified in other portions of the Contract Documents and as amended by the State of California Department of Transportation, (k) The Standard Plans of the Department of Transportation identified on the plans or in the Special Provisions, (l) The Plans, (m) Addenda **(One)**, (n) The Determination of Prevailing Wage Rates for Public Work, (o) Any Change Orders issued, (p) Any additional or supplemental specifications, notice, instructions and drawings issued in accordance with the provisions of the Contract Documents. All of said Documents presently in existence are by this reference incorporated herein with like effect as if here set forth in full and upon the proper issuance of other documents they shall likewise be deemed incorporated. The Bid Bond is exonerated upon execution of this Contract and the Payment Bond and Performance Bond.

2. The Work

Contractor shall do all tasks necessary to construct the work generally described in Recital No. 1 in accordance with the Contract Documents.

3. Prosecution, Progress and Liquidated Damages

Attention is directed to the provisions in Section 8-1.04, "Start of Job Site Activities", Section 8-1.05, "Time", and in Section 8-1.10 "Liquidated Damages" of the Standard Specifications and these Special Provisions.

Standard Specification Section 8-1.04B, "Standard Start" is modified to read as follows:

The Contractor shall begin work within fifteen (15) calendar days, or as revised in the Special Provisions, of the date stated within the written "Notice to Proceed".

The Contractor shall notify the Engineer, in writing, of the Contractor's intent to begin work at least 72 hours before work is begun. If the project has more than one (1) location of work, Contractor shall submit a separate notice for each location. The notice shall be delivered to the Transportation Department's Construction Engineer and shall specify the date the Contractor intends to start at said location.

Should the Contractor begin work in advance of receiving a written "Notice to Proceed", any work performed by the Contractor in advance of the date stated in the "Notice to Proceed" shall be considered as having been done by the Contractor at his own risk and as a volunteer and subject to the following:

- A. The Contractor shall, on commencing operations, take all precautions required for public safety and shall observe all the provisions in the Specifications and the Special Provisions.
- B. All work done according to the Contract, prior to the issuance of the "Notice to Proceed", will be considered authorized work and will be paid for as provided in the contract.
- C. The Contractor shall not be entitled to any additional compensation or an extension of time for any delay, hindrance or interference caused by or attributable to commencement of work prior to the issuance of the "Notice to Proceed".

4. Compensation

Contractor shall be paid in the manner set forth in the Contract Documents the amount of his Proposal as accepted by County, the above rates, subject to additions and deductions as provided in the Contract Documents. Said Proposal is on file in the Office of the Clerk of the Board of Supervisors of County.

**Serfas Club Drive and Monterey Peninsula Drive  
Traffic Signal and Lighting Project  
In the Community of Coronita  
Project No. C5-0073**

**Contract**

ITEM No.	ITEM CODE	ITEM	UNIT	ESTIMATED QUANTITY	ITEM PRICE (IN FIGURES)	TOTAL (IN FIGURES)
<b>BASE BID</b>						
1	130200	PREPARE WATER POLLUTION CONTROL PROGRAM	LS	1	900.00	900.00
2	120100	TRAFFIC CONTROL SYSTEM	LS	1	15,000.00	15,000.00
3	170101	DEVELOP WATER SUPPLY	LS	1	1,000.00	1,000.00
4	066100	DUST CONTROL	LS	1	3,500.00	3,500.00
5	160101	CLEARING AND GRUBBING	LS	1	4,000.00	4,000.00
6	190101	ROADWAY EXCAVATION	CY	50	248.00	12,400.00
7	153103	COLD PLANE ASPHALT CONCRETE PAVEMENT	SQYD	675	11.00	7,425.00
8	390130	HOT MIX ASPHALT	TON	150	225.00	33,750.00
9	017316	MINOR CONCRETE (CURB RAMP) (CRS 403 - CASE B)	EA	4	3,200.00	12,800.00
10	017317	MINOR CONCRETE (CROSS-GUTTER AND SPANDREL)	SQFT	1,700	9.00	15,300.00
11	000001	ITEM DELETED BY ADDENDUM	----	-----	-----	-----
12	731521	MINOR CONCRETE (SIDEWALK)	SQFT	100	18.44	1,844.00
13	017305	MINOR CONCRETE (CURB AND GUTTER) (CRS 201)	LF	40	36.00	1,440.00
14	513553	RETAINING WALL (MASONRY WALL) [PER CONSTRUCTION NOTE 9]	LF	50	207.00	10,350.00
14.A	513553	RETAINING WALL (MASONRY WALL) [PER CONSTRUCTION NOTE 13]	LF	30	258.00	7,740.00
14.B	839514	HAND RAILING [PER APWA STD 606-3, TYPE B]	LF	60	50.00	3,000.00
15	000003	REPLACE DAMAGED PLANTS/SOD	LS	1	2,500.00	2,500.00
16	860201	SIGNAL AND LIGHTING	LS	1	216,531.00	216,531.00
17	150710	REMOVE TRAFFIC STRIPE	LF	300	0.60	180.00
18	150715	REMOVE THERMOPLASTIC PAVEMENT MARKING	SQFT	600	2.90	1,740.00
19	840656	PAINT TRAFFIC STRIPE (2-COAT)	LF	8,300	0.25	2,075.00
20	840515	THERMOPLASTIC PAVEMENT MARKING	SQFT	550	4.30	2,365.00
21	850111	PAVEMENT MARKER (RETROREFLECTIVE)	EA	210	2.90	609.00
22	566011	ROADSIDE SIGN - ONE POST	EA	2	272.00	544.00
23	150742	REMOVE (AND SALVAGE) EXISTING SIGN (AND POST)	EA	11	63.00	693.00
24	015602	FUNDING AWARENESS SIGN	EA	2	1,200.00	2,400.00
25	010602	MISCELLANEOUS WORK (AS DIRECTED)	FA	1	30,000.00	30,000.00
26	019901	DE-MOBILIZATION	LS	1	10,000.00	10,000.00

PROJECT

TOTAL: Four hundred thousand, eighty six dollars and zero cents

**\$400,086.00**

ITEMS 1-26

"WORDS"

**Serfas Club Drive and Monterey Peninsula Drive  
Traffic Signal and Lighting Project  
In the Community of Coronita  
Project No. C5-0073**

IN WITNESS WHEREOF the parties hereto have executed this Contract as of the date set forth below.

**COUNTY OF RIVERSIDE**

**DBX, INC.**

BY: \_\_\_\_\_

BY:  \_\_\_\_\_

Chairman, Board of Supervisors

TITLE: President  
(If Corporation, affix Seal)

DATED: \_\_\_\_\_

ATTEST:

ATTEST:  
\_\_\_\_\_

Kecia Harper-Ihem, Clerk of the Board

BY: \_\_\_\_\_

TITLE: \_\_\_\_\_

Deputy

Licensed in accordance with an act providing  
for the registration of Contractors,

License No. 240547

Federal Employer Identification Number:

95-2458707

BY \_\_\_\_\_

DBX, Inc.

"County"

"Corporation"  
(Seal)

**CALIFORNIA ALL-PURPOSE ACKNOWLEDGMENT**

**CIVIL CODE § 1189**

A notary public or other officer completing this certificate verifies only the identity of the individual who signed the document to which this certificate is attached, and not the truthfulness, accuracy, or validity of that document.

State of California )  
County of Riverside )

On July 30, 2015 before me, Phyllissa Martz, Notary Public  
*Date Here Insert Name and Title of the Officer*

personally appeared Jim Perry  
*Name(s) of Signer(s)*

who proved to me on the basis of satisfactory evidence to be the person(s) whose name(s) is/are subscribed to the within instrument and acknowledged to me that he/she/they executed the same in his/her/their authorized capacity(ies), and that by his/her/their signature(s) on the instrument the person(s), or the entity upon behalf of which the person(s) acted, executed the instrument.

I certify under PENALTY OF PERJURY under the laws of the State of California that the foregoing paragraph is true and correct.

WITNESS my hand and official seal.

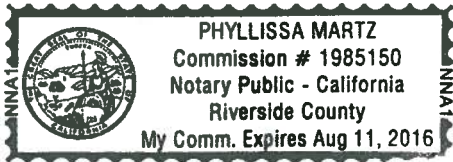

Signature Phyllissa Martz  
*Signature of Notary Public*

*Place Notary Seal Above*

**OPTIONAL**

*Though this section is optional, completing this information can deter alteration of the document or fraudulent reattachment of this form to an unintended document.*

**Description of Attached Document**

Title or Type of Document: \_\_\_\_\_ Document Date: \_\_\_\_\_

Number of Pages: \_\_\_\_\_ Signer(s) Other Than Named Above: \_\_\_\_\_

**Capacity(ies) Claimed by Signer(s)**

Signer's Name: Jim Perry

Corporate Officer -- Title(s): President

Partner --  Limited  General

Individual  Attorney in Fact

Trustee  Guardian or Conservator

Other: \_\_\_\_\_

Signer Is Representing: \_\_\_\_\_

Signer's Name: \_\_\_\_\_

Corporate Officer -- Title(s): \_\_\_\_\_

Partner --  Limited  General

Individual  Attorney in Fact

Trustee  Guardian or Conservator

Other: \_\_\_\_\_

Signer Is Representing: \_\_\_\_\_



RESOLUTION OF OFFICER'S AUTHORITY

"WHEREAS, from time to time this corporation, being DBX, Inc., a California corporation, is called upon to execute documents by which this corporation enters into contracts, bonds, obligations of performance, surety and of other legal consequences, and

"WHEREAS, third persons may require or request come written authority evidencing and identifying those persons who are officers and authorized to execute such documents for and on behalf of this corporation, now, therefore, it is

"RESOLVED, that JIM PERRY, who is President and Chief Executive Officer of this corporation, be, and he hereby is, and has been, empowered, authorized and directed to execute any and all kinds of documents, contracts, bonds, obligations of performance, surety and other documents by which this corporation assumes legal obligations, dealing with private and public entities, and

"RESOLVED FURTHER, that any person who relies upon the authority granted and conferred in this resolution shall be indemnified and held harmless from any claim with respect to the existence or non-existence of such authority, and may continue to do so until personally receiving written notice that the authority herein conferred has been terminated."

Dated: August 12, 1991

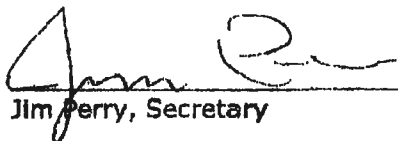
  
Jim Perry, Secretary

SEAL

## Performance Bond

**Recitals:**

1. **DBX, INC.** (Contractor) has entered into a Contract with COUNTY OF RIVERSIDE (County) for construction of public work known as **Serfas Club Drive and Monterey Peninsula Drive, Traffic Signal and Lighting Project, In the Community of Coronita, Project No. C5-0073.**
  
2. \_\_\_\_\_, a \_\_\_\_\_ corporation (Surety), is the Surety under this Bond.

**Agreement:**

We, Contractor as Principal and Surety as Surety, jointly and severally agree, state, and are bound unto County, as obligee, as follows:

1. The amount of the obligation of this Bond is 100% of the estimated contract price for the Project of **\$400,086.00 (Fourhundred thousand, eighty six dollars and zero cents)** and inures to the benefit of County.
  
2. This Bond is exonerated by Contractor doing all things to be kept and performed by it in strict conformance with the Contract Documents for this project, otherwise it remains in full force and effect for the recovery of loss, damage and expense of County resulting from failure of Contractor to so act. All of said Contract Documents are incorporated herein.
  
3. This obligation is binding on our successors and assigns.
  
4. For value received, Surety stipulates and agrees that no change, time extension, prepayment to Contractor, alteration or addition to the terms and requirements of the Contract Documents or the work to be performed thereunder shall affect its obligations hereunder and waives notice as to such matters, except the total contract price cannot be increased by more than 10% without approval of Surety.

THIS BOND is executed as of \_\_\_\_\_.

By \_\_\_\_\_

By \_\_\_\_\_

By \_\_\_\_\_

Type Name \_\_\_\_\_

Its Attorney in Fact  
"Surety"

Title \_\_\_\_\_

"Contractor"

(Corporate Seal)

(Corporate Seal)

**NOTE: This Bond must be executed by both parties with corporate seal affixed. All signatures must be acknowledged. (Attach acknowledgements).**



**Payment Bond**

(Public Works - Civil Code §9550 et seq.)

The makers of this Bond are DBX, INC., as Principal and Original Contractor and \_\_\_\_\_, a corporation, authorized to issue Surety Bonds in California, as Surety, and this Bond is issued in conjunction with that certain public works contract to be executed between Principal and COUNTY OF RIVERSIDE a public entity, as Owner, for \$400,086.00 (Fourhundred thousand, eighty six dollars and zero cents), the total amount payable. The amount of this bond is one hundred percent (100%) of said sum. Said contract is for public work generally consisting of Serfas Club Drive and Monterey Peninsula Drive, Traffic Signal and Lighting Project, In the Community of Coronita, Project No. C5-0073.

The beneficiaries of this Bond are as is stated in 9554 of the Civil Code and requirements and conditions of this Bond are as is set forth in 9554, 9558, 9560 and 9564 of said code. Without notice, Surety consents to extension of time for performance, change in requirements, amount of compensation, or prepayment under said contract.

Dated: \_\_\_\_\_

\_\_\_\_\_  
Original Contractor – Principal

\_\_\_\_\_  
Surety

By \_\_\_\_\_

By \_\_\_\_\_

Its Attorney In Fact

Title \_\_\_\_\_

(If corporation, affix seal)

(Corporate Seal)

(Corporate Seal)

STATE OF \_\_\_\_\_ }  
COUNTY OF \_\_\_\_\_ }

ss. SURETY'S ACKNOWLEDGEMENT

On \_\_\_\_\_ before me, \_\_\_\_\_ personally appeared, \_\_\_\_\_, known to me, or proved to me on the basis of satisfactory evidence, to be the person whose name is subscribed to the within instrument and acknowledged to me that he executed the same in his authorized capacities, and that by his signature on the instrument the person, or the entity upon behalf of which the person acted, executed the instrument.

WITNESS my hand and official seal.

\_\_\_\_\_  
Signature of Notary Public

Notary Public (Seal)

**NOTE: This Bond must be executed by both parties with corporate seal affixed. All signatures must be acknowledged. (Attach acknowledgements).**

**Performance Bond**

**Recitals:**

1. **DBX, INC.** (Contractor) has entered into a Contract with COUNTY OF RIVERSIDE (County) for construction of public work known as **Serfas Club Drive and Monterey Peninsula Drive, Traffic Signal and Lighting Project, In the Community of Coronita, Project No. C5-0073.**

THE GUARANTEE COMPANY OF

2. **NORTH AMERICA USA**, a **MICHIGAN** corporation (Surety), is the Surety under this Bond.

**Agreement:**

We, Contractor as Principal and Surety as Surety, jointly and severally agree, state, and are bound unto County, as obligee, as follows:

1. The amount of the obligation of this Bond is 100% of the estimated contract price for the Project of **\$400,086.00 (Four hundred thousand, eighty six dollars and zero cents)** and inures to the benefit of County.
2. This Bond is exonerated by Contractor doing all things to be kept and performed by it in strict conformance with the Contract Documents for this project, otherwise it remains in full force and effect for the recovery of loss, damage and expense of County resulting from failure of Contractor to so act. All of said Contract Documents are incorporated herein.
3. This obligation is binding on our successors and assigns.
4. For value received, Surety stipulates and agrees that no change, time extension, prepayment to Contractor, alteration or addition to the terms and requirements of the Contract Documents or the work to be performed thereunder shall affect its obligations hereunder and waives notice as to such matters, except the total contract price cannot be increased by more than 10% without approval of Surety.

THIS BOND is executed as of JULY 21, 2015

DBX, INCORPORATED

THE GUARANTEE COMPANY OF NORTH AMERICA USA

By \_\_\_\_\_

By 

By 

Type Name CHARLES L. FLAKE

Its Attorney in Fact  
"Surety"

Title President

"Contractor"

(Corporate Seal)

(Corporate Seal)

**NOTE: This Bond must be executed by both parties with corporate seal affixed. All signatures must be acknowledged. (Attach acknowledgements).**

**CALIFORNIA ALL-PURPOSE ACKNOWLEDGMENT**

**CIVIL CODE § 1189**

A notary public or other officer completing this certificate verifies only the identity of the individual who signed the document to which this certificate is attached, and not the truthfulness, accuracy, or validity of that document.

State of California )  
County of Riverside )

On July 30, 2015 before me, Phyllissa Martz, Notary Public  
*Date Here Insert Name and Title of the Officer*

personally appeared Jim Perry  
*Name(s) of Signer(s)*

who proved to me on the basis of satisfactory evidence to be the person(s) whose name(s) is/are subscribed to the within instrument and acknowledged to me that he/she/they executed the same in his/her/their authorized capacity(ies), and that by his/her/their signature(s) on the instrument the person(s), or the entity upon behalf of which the person(s) acted, executed the instrument.

I certify under PENALTY OF PERJURY under the laws of the State of California that the foregoing paragraph is true and correct.

WITNESS my hand and official seal.

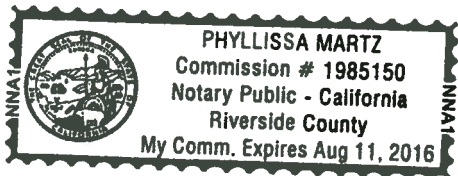

Signature Phyllissa Martz  
*Signature of Notary Public*

Place Notary Seal Above

**OPTIONAL**

Though this section is optional, completing this information can deter alteration of the document or fraudulent reattachment of this form to an unintended document.

**Description of Attached Document**

Title or Type of Document: \_\_\_\_\_ Document Date: \_\_\_\_\_  
Number of Pages: \_\_\_\_\_ Signer(s) Other Than Named Above: \_\_\_\_\_

**Capacity(ies) Claimed by Signer(s)**

Signer's Name: Jim Perry  
 Corporate Officer — Title(s): President  
 Partner —  Limited  General  
 Individual  Attorney in Fact  
 Trustee  Guardian or Conservator  
 Other: \_\_\_\_\_  
Signer Is Representing: \_\_\_\_\_

Signer's Name: \_\_\_\_\_  
 Corporate Officer — Title(s): \_\_\_\_\_  
 Partner —  Limited  General  
 Individual  Attorney in Fact  
 Trustee  Guardian or Conservator  
 Other: \_\_\_\_\_  
Signer Is Representing: \_\_\_\_\_

# CALIFORNIA ALL-PURPOSE ACKNOWLEDGMENT

A notary public or other officer completing this certificate verifies only the identity of the individual who signed the document to which this certificate is attached, and not the truthfulness, accuracy, or validity of that document.

STATE OF CALIFORNIA

County of Orange }

On 7-21-15 before me, Lexie Sherwood, Notary Public,  
Date Insert Name of Notary exactly as it appears on the official seal

personally appeared Charles L. Flake

Name(s) of Signer(s)



Place Notary Seal Above

who proved to me on the basis of satisfactory evidence to be the person(s) whose name(s) is/are subscribed to the within instrument and acknowledged to me that he/she/they executed the same in his/her/their authorized capacity(ies), and that by his/her/their signature(s) on the instrument the person(s), or the entity upon behalf of which the person(s) acted, executed the instrument.

I certify under PENALTY OF PERJURY under the laws of the State of California that the foregoing paragraph is true and correct.

Witness my hand and official seal.

Signature

Lexie Sherwood  
Signature of Notary Public Lexie Sherwood

## OPTIONAL

Though the information below is not required by law, it may prove valuable to persons relying on the document and could prevent fraudulent removal and reattachment of the form to another document.

### Description of Attached Document

Title or Type of Document: \_\_\_\_\_

Document Date: \_\_\_\_\_

Number of Pages: \_\_\_\_\_

Signer(s) Other Than Named Above: \_\_\_\_\_

### Capacity(ies) Claimed by Signer(s)

Signer's Name: \_\_\_\_\_

- Individual
- Corporate Officer — Title(s): \_\_\_\_\_
- Partner  Limited  General
- Attorney in Fact
- Trustee
- Guardian or Conservator
- Other: \_\_\_\_\_

RIGHT THUMBPRINT  
OF SIGNER

Top of thumb here

Signer is Representing:  
\_\_\_\_\_  
\_\_\_\_\_  
\_\_\_\_\_

Signer's Name: \_\_\_\_\_

- Individual
- Corporate Officer — Title(s): \_\_\_\_\_
- Partner  Limited  General
- Attorney in Fact
- Trustee
- Guardian or Conservator
- Other: \_\_\_\_\_

RIGHT THUMBPRINT  
OF SIGNER

Top of thumb here

Signer is Representing:  
\_\_\_\_\_  
\_\_\_\_\_  
\_\_\_\_\_



**THE GUARANTEE™**

**The Guarantee Company of North America USA**  
Southfield, Michigan

**POWER OF ATTORNEY**

**KNOW ALL BY THESE PRESENTS:** That **THE GUARANTEE COMPANY OF NORTH AMERICA USA**, a corporation organized and existing under the laws of the State of Michigan, having its principal office in Southfield, Michigan, does hereby constitute and appoint

David L. Culbertson, Charles L. Flake, Richard A. Coon, Spencer Flake  
Culbertson Insurance Services, Inc.

its true and lawful attorney(s)-in-fact to execute, seal and deliver for and on its behalf as surety, any and all bonds and undertakings, contracts of indemnity and other writings obligatory in the nature thereof, which are or may be allowed, required or permitted by law, statute, rule, regulation, contract or otherwise.

The execution of such instrument(s) in pursuance of these presents, shall be as binding upon **THE GUARANTEE COMPANY OF NORTH AMERICA USA** as fully and amply, to all intents and purposes, as if the same had been duly executed and acknowledged by its regularly elected officers at the principal office.

The Power of Attorney is executed and may be certified so, and may be revoked, pursuant to and by authority of Article IX, Section 9.03 of the By-Laws adopted by the Board of Directors of **THE GUARANTEE COMPANY OF NORTH AMERICA USA** at a meeting held on the 31<sup>st</sup> day of December, 2003. The President, or any Vice President, acting with any Secretary or Assistant Secretary, shall have power and authority:

1. To appoint Attorney(s)-in-fact, and to authorize them to execute on behalf of the Company, and attach the Seal of the Company thereto, bonds and undertakings, contracts of indemnity and other writings obligatory in the nature thereof; and
2. To revoke, at any time, any such Attorney-in-fact and revoke the authority given, except as provided below
3. In connection with obligations in favor of the Florida Department of Transportation only, it is agreed that the power and authority hereby given to the Attorney-in-Fact includes any and all consents for the release of retained percentages and/or final estimates on engineering and construction contracts required by the State of Florida Department of Transportation. It is fully understood that consenting to the State of Florida Department of Transportation making payment of the final estimate to the Contractor and/or its assignee, shall not relieve this surety company of any of its obligations under its bond.
4. In connection with obligations in favor of the Kentucky Department of Highways only, it is agreed that the power and authority hereby given to the Attorney-in-Fact cannot be modified or revoked unless prior written personal notice of such intent has been given to the Commissioner – Department of Highways of the Commonwealth of Kentucky at least thirty (30) days prior to the modification or revocation.

Further, this Power of Attorney is signed and sealed by facsimile pursuant to resolution of the Board of Directors of the Company adopted at a meeting duly called and held on the 6th day of December 2011, of which the following is a true excerpt:

RESOLVED that the signature of any authorized officer and the seal of the Company may be affixed by facsimile to any Power of Attorney or certification thereof authorizing the execution and delivery of any bond, undertaking, contracts of indemnity and other writings obligatory in the nature thereof, and such signature and seal when so used shall have the same force and effect as though manually affixed.



IN WITNESS WHEREOF, **THE GUARANTEE COMPANY OF NORTH AMERICA USA** has caused this instrument to be signed and its corporate seal to be affixed by its authorized officer, this 23rd day of February, 2012.

**THE GUARANTEE COMPANY OF NORTH AMERICA USA**

STATE OF MICHIGAN  
County of Oakland

Stephen C. Ruschak, President & COO

Randall Musselman, Secretary

On this 23rd day of February, 2012 before me came the individuals who executed the preceding instrument, to me personally known, and being by me duly sworn, said that each is the herein described and authorized officer of The Guarantee Company of North America USA; that the seal affixed to said instrument is the Corporate Seal of said Company; that the Corporate Seal and each signature were duly affixed by order of the Board of Directors of



Cynthia A. Takal  
Notary Public, State of Michigan  
County of Oakland  
My Commission Expires February 27, 2018  
Acting in Oakland County

IN WITNESS WHEREOF, I have hereunto set my hand at The Guarantee Company of North America USA offices the day and year above written.

I, Randall Musselman, Secretary of **THE GUARANTEE COMPANY OF NORTH AMERICA USA**, do hereby certify that the above and foregoing is a true and correct copy of a Power of Attorney executed by **THE GUARANTEE COMPANY OF NORTH AMERICA USA**, which is still in full force and effect.



IN WITNESS WHEREOF, I have thereunto set my hand and attached the seal of said Company this 21st day of July, 2015

Randall Musselman, Secretary



- Company Profile
- Company Search
- Company Information
- Old Company Names
- Agent for Service
- Reference Information
- NAIC Group List
- Lines of Business
- Workers' Compensation
- Complaint and Request for Action/Appeals
- Contact Information
- Financial Statements PDF's
- Annual Statements
- Quarterly Statements
- Company Complaint
- Company Performance & Comparison Data
- Company Enforcement Action
- Composite Complaints Studies
- Additional Info
- Find A Company Representative In Your Area
- View Financial Disclaimer

**COMPANY PROFILE**

**Company Information**

**GUARANTEE COMPANY OF NORTH AMERICA USA (THE)**  
**ONE TOWNE SQUARE, SUITE 1470**  
**SOUTHFIELD, MI 48076**

Old Company Names	Effective Date
MID-STATE SURETY CORPORATION	12/20/2006

**Agent For Service**  
 NANCY FLORES  
 C/O CT CORPORATION SYSTEM  
 818 WEST SEVENTH STREET, SUITE 930  
 LOS ANGELES CA 90017

**Reference Information**

NAIC #:	36650
California Company ID #:	4609-4
Date Authorized in California:	10/14/1999
License Status:	UNLIMITED-NORMAL
Company Type:	Property & Casualty
State of Domicile:	MICHIGAN

[back to top](#)

**NAIC Group List**

NAIC Group #: 0000

**Lines Of Business**

The company is authorized to transact business within these lines of insurance. For an explanation of any of these terms, please refer to the [glossary](#).

- AUTOMOBILE
- BOILER AND MACHINERY
- BURGLARY
- COMMON CARRIER LIABILITY
- CREDIT
- FIRE
- LEGAL INSURANCE
- LIABILITY
- MARINE
- MISCELLANEOUS
- PLATE GLASS
- SPRINKLER
- SURETY
- TEAM AND VEHICLE

[back to top](#)

**Payment Bond**

(Public Works - Civil Code §9550 et seq.)

The makers of this Bond are DBX, INC., as Principal and Original Contractor and THE GUARANTEE COMPANY OF NORTH AMERICA USA, a corporation, authorized to issue Surety Bonds in California, as Surety, and this Bond is issued in conjunction with that certain public works contract to be executed between Principal and COUNTY OF RIVERSIDE a public entity, as Owner, for \$400,086.00 (Fourhundred thousand, eighty six dollars and zero cents), the total amount payable. The amount of this bond is one hundred percent (100%) of said sum. Said contract is for public work generally consisting of Serfas Club Drive and Monterey Peninsula Drive, Traffic Signal and Lighting Project, In the Community of Coronita, Project No. C5-0073.

The beneficiaries of this Bond are as is stated in 9554 of the Civil Code and requirements and conditions of this Bond are as is set forth in 9554, 9558, 9560 and 9564 of said code. Without notice, Surety consents to extension of time for performance, change in requirements, amount of compensation, or prepayment under said contract.

Dated: JULY 21, 2015

DBX, Inc.  
Original Contractor – Principal

THE GUARANTEE COMPANY OF  
NORTH AMERICA USA  
Surety

By 

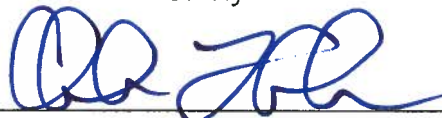
By   
CHARLES L. FLAKE  
Its Attorney In Fact

Title President  
(If corporation, affix seal)

(Corporate Seal)

(Corporate Seal)

STATE OF \_\_\_\_\_ }  
COUNTY OF \_\_\_\_\_ } ss. SURETY'S ACKNOWLEDGEMENT

On \_\_\_\_\_ before me, \_\_\_\_\_ personally appeared, \_\_\_\_\_, known to me, or proved to me on the basis of satisfactory evidence, to be the person whose name is subscribed to the within instrument and acknowledged to me that he executed the same in his authorized capacities, and that by his signature on the instrument the person, or the entity upon behalf of which the person acted, executed the instrument.

WITNESS my hand and official seal.

\_\_\_\_\_  
Signature of Notary Public

Notary Public (Seal)

**NOTE: This Bond must be executed by both parties with corporate seal affixed. All signatures must be acknowledged. (Attach acknowledgements).**





**CALIFORNIA ALL-PURPOSE ACKNOWLEDGMENT**

**CIVIL CODE § 1189**

A notary public or other officer completing this certificate verifies only the identity of the individual who signed the document to which this certificate is attached, and not the truthfulness, accuracy, or validity of that document.

State of California )  
County of Riverside )

On July 30, 2015 before me, Phyllissa Martz, Notary Public  
*Date Here Insert Name and Title of the Officer*

personally appeared Jim Perry  
*Name(s) of Signer(s)*

who proved to me on the basis of satisfactory evidence to be the person(s) whose name(s) is/are subscribed to the within instrument and acknowledged to me that he/she/they executed the same in his/her/their authorized capacity(ies), and that by his/her/their signature(s) on the instrument the person(s), or the entity upon behalf of which the person(s) acted, executed the instrument.

I certify under PENALTY OF PERJURY under the laws of the State of California that the foregoing paragraph is true and correct.

WITNESS my hand and official seal.

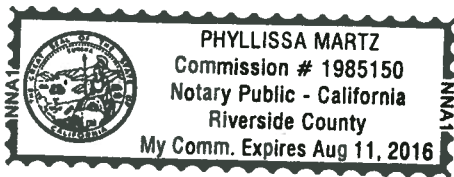

Signature Phyllissa Martz  
*Signature of Notary Public*

Place Notary Seal Above

**OPTIONAL**

Though this section is optional, completing this information can deter alteration of the document or fraudulent reattachment of this form to an unintended document.

**Description of Attached Document**

Title or Type of Document: \_\_\_\_\_ Document Date: \_\_\_\_\_

Number of Pages: \_\_\_\_\_ Signer(s) Other Than Named Above: \_\_\_\_\_

**Capacity(ies) Claimed by Signer(s)**

Signer's Name: Jim Perry

Corporate Officer — Title(s): President

Partner —  Limited  General

Individual  Attorney in Fact

Trustee  Guardian or Conservator

Other: \_\_\_\_\_

Signer Is Representing: \_\_\_\_\_

Signer's Name: \_\_\_\_\_

Corporate Officer — Title(s): \_\_\_\_\_

Partner —  Limited  General

Individual  Attorney in Fact

Trustee  Guardian or Conservator

Other: \_\_\_\_\_

Signer Is Representing: \_\_\_\_\_



# CALIFORNIA ALL-PURPOSE ACKNOWLEDGMENT

A notary public or other officer completing this certificate verifies only the identity of the individual who signed the document to which this certificate is attached, and not the truthfulness, accuracy, or validity of that document.

STATE OF CALIFORNIA

County of Orange }

On 7-21-15 before me, Lexie Sherwood, Notary Public,  
Date Insert Name of Notary exactly as it appears on the official seal

personally appeared Charles L. Flake

Name(s) of Signer(s)



Place Notary Seal Above

who proved to me on the basis of satisfactory evidence to be the person(s) whose name(s) is/are subscribed to the within instrument and acknowledged to me that he/she/they executed the same in his/her/their authorized capacity(ies), and that by his/her/their signature(s) on the instrument the person(s), or the entity upon behalf of which the person(s) acted, executed the instrument.

I certify under PENALTY OF PERJURY under the laws of the State of California that the foregoing paragraph is true and correct.

Witness my hand and official seal.

Signature

Lexie Sherwood  
Signature of Notary Public Lexie Sherwood

## OPTIONAL

Though the information below is not required by law, it may prove valuable to persons relying on the document and could prevent fraudulent removal and reattachment of the form to another document.

### Description of Attached Document

Title or Type of Document: \_\_\_\_\_

Document Date: \_\_\_\_\_ Number of Pages: \_\_\_\_\_

Signer(s) Other Than Named Above: \_\_\_\_\_

### Capacity(ies) Claimed by Signer(s)

Signer's Name: \_\_\_\_\_

- Individual
- Corporate Officer — Title(s): \_\_\_\_\_
- Partner  Limited  General
- Attorney in Fact
- Trustee
- Guardian or Conservator
- Other: \_\_\_\_\_

RIGHT THUMBPRINT  
OF SIGNER

Top of thumb here

Signer is Representing: \_\_\_\_\_

Signer's Name: \_\_\_\_\_

- Individual
- Corporate Officer — Title(s): \_\_\_\_\_
- Partner  Limited  General
- Attorney in Fact
- Trustee
- Guardian or Conservator
- Other: \_\_\_\_\_

RIGHT THUMBPRINT  
OF SIGNER

Top of thumb here

Signer is Representing: \_\_\_\_\_



The Guarantee Company of North America USA  
Southfield, Michigan

POWER OF ATTORNEY

KNOW ALL BY THESE PRESENTS: That THE GUARANTEE COMPANY OF NORTH AMERICA USA, a corporation organized and existing under the laws of the State of Michigan, having its principal office in Southfield, Michigan, does hereby constitute and appoint

David L. Culbertson, Charles L. Flake, Richard A. Coon, Spencer Flake  
Culbertson Insurance Services, Inc.

its true and lawful attorney(s)-in-fact to execute, seal and deliver for and on its behalf as surety, any and all bonds and undertakings, contracts of indemnity and other writings obligatory in the nature thereof, which are or may be allowed, required or permitted by law, statute, rule, regulation, contract or otherwise.

The execution of such instrument(s) in pursuance of these presents, shall be as binding upon THE GUARANTEE COMPANY OF NORTH AMERICA USA as fully and amply, to all intents and purposes, as if the same had been duly executed and acknowledged by its regularly elected officers at the principal office.

The Power of Attorney is executed and may be certified so, and may be revoked, pursuant to and by authority of Article IX, Section 9.03 of the By-Laws adopted by the Board of Directors of THE GUARANTEE COMPANY OF NORTH AMERICA USA at a meeting held on the 31<sup>st</sup> day of December, 2003. The President, or any Vice President, acting with any Secretary or Assistant Secretary, shall have power and authority:

1. To appoint Attorney(s)-in-fact, and to authorize them to execute on behalf of the Company, and attach the Seal of the Company thereto, bonds and undertakings, contracts of indemnity and other writings obligatory in the nature thereof; and
2. To revoke, at any time, any such Attorney-in-fact and revoke the authority given, except as provided below
3. In connection with obligations in favor of the Florida Department of Transportation only, it is agreed that the power and authority hereby given to the Attorney-in-Fact includes any and all consents for the release of retained percentages and/or final estimates on engineering and construction contracts required by the State of Florida Department of Transportation. It is fully understood that consenting to the State of Florida Department of Transportation making payment of the final estimate to the Contractor and/or its assignee, shall not relieve this surety company of any of its obligations under its bond.
4. In connection with obligations in favor of the Kentucky Department of Highways only, it is agreed that the power and authority hereby given to the Attorney-in-Fact cannot be modified or revoked unless prior written personal notice of such intent has been given to the Commissioner – Department of Highways of the Commonwealth of Kentucky at least thirty (30) days prior to the modification or revocation.

Further, this Power of Attorney is signed and sealed by facsimile pursuant to resolution of the Board of Directors of the Company adopted at a meeting duly called and held on the 6th day of December 2011, of which the following is a true excerpt:

RESOLVED that the signature of any authorized officer and the seal of the Company may be affixed by facsimile to any Power of Attorney or certification thereof authorizing the execution and delivery of any bond, undertaking, contracts of indemnity and other writings obligatory in the nature thereof, and such signature and seal when so used shall have the same force and effect as though manually affixed.



IN WITNESS WHEREOF, THE GUARANTEE COMPANY OF NORTH AMERICA USA has caused this instrument to be signed and its corporate seal to be affixed by its authorized officer, this 23rd day of February, 2012.

THE GUARANTEE COMPANY OF NORTH AMERICA USA

STATE OF MICHIGAN  
County of Oakland

Stephen C. Ruschak, President & COO

Randall Musselman, Secretary

On this 23rd day of February, 2012 before me came the individuals who executed the preceding instrument, to me personally known, and being by me duly sworn, said that each is the herein described and authorized officer of The Guarantee Company of North America USA; that the seal affixed to said instrument is the Corporate Seal of said Company; that the Corporate Seal and each signature were duly affixed by order of the Board of Directors of



Cynthia A. Takai  
Notary Public, State of Michigan  
County of Oakland  
My Commission Expires February 27, 2018  
Acting in Oakland County

IN WITNESS WHEREOF, I have hereunto set my hand at The Guarantee Company of North America USA offices the day and year above written.

I, Randall Musselman, Secretary of THE GUARANTEE COMPANY OF NORTH AMERICA USA, do hereby certify that the above and foregoing is a true and correct copy of a Power of Attorney executed by THE GUARANTEE COMPANY OF NORTH AMERICA USA, which is still in full force and effect.



IN WITNESS WHEREOF, I have thereunto set my hand and attached the seal of said Company this 21st day of July, 2015

Randall Musselman, Secretary



- Company Profile
- Company Search
- Company Information
- Old Company Names
- Agent for Service
- Reference Information
- NAIC Group List
- Lines of Business
- Workers' Compensation
- Complaint and Request for Action/Appeals
- Contact Information
- Financial Statements PDF's
  - Annual Statements
  - Quarterly Statements
- Company Complaint
  - Company Performance & Comparison Data
  - Company Enforcement Action
  - Composite Complaints Studies
- Additional Info
  - Find A Company Representative In Your Area
  - View Financial Disclaimer

## COMPANY PROFILE

### Company Information

**GUARANTEE COMPANY OF NORTH AMERICA USA (THE)**  
**ONE TOWNE SQUARE, SUITE 1470**  
**SOUTHFIELD, MI 48076**

Old Company Names	Effective Date
MID-STATE SURETY CORPORATION	12/20/2006

### Agent For Service

NANCY FLORES  
 C/O CT CORPORATION SYSTEM  
 818 WEST SEVENTH STREET, SUITE 930  
 LOS ANGELES CA 90017

### Reference Information

NAIC #:	36650
California Company ID #:	4609-4
Date Authorized in California:	10/14/1999
License Status:	UNLIMITED-NORMAL
Company Type:	Property & Casualty
State of Domicile:	MICHIGAN

[back to top](#)

### NAIC Group List

NAIC Group #: [0000](#)

### Lines Of Business

The company is authorized to transact business within these lines of insurance. For an explanation of any of these terms, please refer to the [glossary](#).

- AUTOMOBILE
- BOILER AND MACHINERY
- BURGLARY
- COMMON CARRIER LIABILITY
- CREDIT
- FIRE
- LEGAL INSURANCE
- LIABILITY
- MARINE
- MISCELLANEOUS
- PLATE GLASS
- SPRINKLER
- SURETY
- TEAM AND VEHICLE

[back to top](#)



# CERTIFICATE OF LIABILITY INSURANCE

DATE (MM/DD/YYYY)

8/10/2015

THIS CERTIFICATE IS ISSUED AS A MATTER OF INFORMATION ONLY AND CONFERS NO RIGHTS UPON THE CERTIFICATE HOLDER. THIS CERTIFICATE DOES NOT AFFIRMATIVELY OR NEGATIVELY AMEND, EXTEND OR ALTER THE COVERAGE AFFORDED BY THE POLICIES BELOW. THIS CERTIFICATE OF INSURANCE DOES NOT CONSTITUTE A CONTRACT BETWEEN THE ISSUING INSURER(S), AUTHORIZED REPRESENTATIVE OR PRODUCER, AND THE CERTIFICATE HOLDER.

**IMPORTANT:** If the certificate holder is an ADDITIONAL INSURED, the policy(ies) must be endorsed. If SUBROGATION IS WAIVED, subject to the terms and conditions of the policy, certain policies may require an endorsement. A statement on this certificate does not confer rights to the certificate holder in lieu of such endorsement(s).

<b>PRODUCER</b> Garrett/Mosier/Griffith/Sistrunk Risk Management & Insurance Services 12 Truman Irvine, CA 92620  www.gmgs.com                      0B84519	<b>CONTACT NAME:</b> PHONE (A/C, No. Ext): (949)559-6700      FAX (A/C, No.): (949)559-6703 E-MAIL ADDRESS:	
	<b>INSURER(S) AFFORDING COVERAGE</b> NAIC # <b>INSURER A:</b> Travelers Indemnity Company of Connecticut                      25682 <b>INSURER B:</b> National Union Fire Ins Co of Pittsburgh, PA                      19445 <b>INSURER C:</b> Everest National Insurance Company                      10120 <b>INSURER D:</b> <b>INSURER E:</b> <b>INSURER F:</b>	

**COVERAGES**

CERTIFICATE NUMBER: 25906560

REVISION NUMBER:

THIS IS TO CERTIFY THAT THE POLICIES OF INSURANCE LISTED BELOW HAVE BEEN ISSUED TO THE INSURED NAMED ABOVE FOR THE POLICY PERIOD INDICATED. NOTWITHSTANDING ANY REQUIREMENT, TERM OR CONDITION OF ANY CONTRACT OR OTHER DOCUMENT WITH RESPECT TO WHICH THIS CERTIFICATE MAY BE ISSUED OR MAY PERTAIN, THE INSURANCE AFFORDED BY THE POLICIES DESCRIBED HEREIN IS SUBJECT TO ALL THE TERMS, EXCLUSIONS AND CONDITIONS OF SUCH POLICIES. LIMITS SHOWN MAY HAVE BEEN REDUCED BY PAID CLAIMS.

INSR LTR	TYPE OF INSURANCE	ADDL INSD	SUBR WVD	POLICY NUMBER	POLICY EFF (MM/DD/YYYY)	POLICY EXP (MM/DD/YYYY)	LIMITS
A	<input checked="" type="checkbox"/> COMMERCIAL GENERAL LIABILITY <input type="checkbox"/> CLAIMS-MADE <input checked="" type="checkbox"/> OCCUR <input checked="" type="checkbox"/> XCU,BFPD,ICP,Wrap Excl <input checked="" type="checkbox"/> Contractual Liability GEN'L AGGREGATE LIMIT APPLIES PER: <input type="checkbox"/> POLICY <input type="checkbox"/> PRO-JECT <input type="checkbox"/> LOC OTHER:			DT22CO7202P439TCT15	3/1/2015	3/1/2016	EACH OCCURRENCE \$ 1,000,000 DAMAGE TO RENTED PREMISES (Ea occurrence) \$ 300,000 MED EXP (Any one person) \$ 5,000 PERSONAL & ADV INJURY \$ 1,000,000 GENERAL AGGREGATE \$ 2,000,000 PRODUCTS - COMP/OP AGG \$ 2,000,000 \$
A	<b>AUTOMOBILE LIABILITY</b> <input checked="" type="checkbox"/> ANY AUTO <input type="checkbox"/> ALL OWNED AUTOS <input type="checkbox"/> SCHEDULED AUTOS <input checked="" type="checkbox"/> HIRED AUTOS <input checked="" type="checkbox"/> NON-OWNED AUTOS			BA7202P439TCT15	3/1/2015	3/1/2016	COMBINED SINGLE LIMIT (Ea accident) \$ 1,000,000 BODILY INJURY (Per person) \$ BODILY INJURY (Per accident) \$ PROPERTY DAMAGE (Per accident) \$ \$
B	<input type="checkbox"/> UMBRELLA LIAB <input checked="" type="checkbox"/> OCCUR <input checked="" type="checkbox"/> EXCESS LIAB <input type="checkbox"/> CLAIMS-MADE DED    RETENTION \$			BE060293302	3/1/2015	3/20/2016	EACH OCCURRENCE \$ 10,000,000 AGGREGATE \$ 10,000,000 \$
C	<b>WORKERS COMPENSATION AND EMPLOYERS' LIABILITY</b> ANY PROPRIETOR/PARTNER/EXECUTIVE OFFICER/MEMBER EXCLUDED? (Mandatory in NH) If yes, describe under DESCRIPTION OF OPERATIONS below	Y/N	N/A	7600005857141	10/1/2014	10/1/2015	<input checked="" type="checkbox"/> PER STATUTE <input type="checkbox"/> OTH-ER E.L. EACH ACCIDENT \$ 1,000,000 E.L. DISEASE - EA EMPLOYEE \$ 1,000,000 E.L. DISEASE - POLICY LIMIT \$ 1,000,000

DESCRIPTION OF OPERATIONS / LOCATIONS / VEHICLES (ACORD 101, Additional Remarks Schedule, may be attached if more space is required)

Serfas Club Drive & Monterey Peninsula Traffic Signal and Lighting Project. In community of Coronita; Project No. C5-0073  
 This certificate may be relied upon only if the certificate addendum referred to herein is attached hereto.

This certificate of insurance amends and supersedes any previously issued certificate.

**CERTIFICATE HOLDER****CANCELLATION**

County of Riverside  
 Transportation Department  
 Attn: Contracts/Bidding Unit  
 3525 14th Street  
 Riverside CA 92501

SHOULD ANY OF THE ABOVE DESCRIBED POLICIES BE CANCELLED BEFORE THE EXPIRATION DATE THEREOF, NOTICE WILL BE DELIVERED IN ACCORDANCE WITH THE POLICY PROVISIONS.

AUTHORIZED REPRESENTATIVE

Calvin Sistrunk

© 1988-2014 ACORD CORPORATION. All rights reserved.



**ADDITIONAL REMARKS SCHEDULE**

<b>AGENCY</b> Garrett/Mosier/Griffith/Sistrunk		<b>NAMED INSURED</b> DBX Inc. 42024 Avenida Alvarado, Suite A Temecula CA 92590	
<b>POLICY NUMBER</b>		<b>EFFECTIVE DATE:</b>	
<b>CARRIER</b>	<b>NAIC CODE</b>		

**ADDITIONAL REMARKS**

**THIS ADDITIONAL REMARKS FORM IS A SCHEDULE TO ACORD FORM,**

**FORM NUMBER:** 25      **FORM TITLE:** Certificate of Liability (01/14)

**HOLDER:** County of Riverside Transportation Department Attn: Contracts/Bidding Unit

**ADDRESS:** 3525 14th Street Riverside CA 92501

Serfas Club Drive & Monterey Peninsula Traffic Signal and Lighting Project. In community of Coronita; Project No. C5-0073

As respects General Liability coverage, County of Riverside, its Agencies, Special Districts and Departments, their respective director, officers, Board of Supervisors, elected and appointed officials, employees, agents, and representatives & The City of Corona Department of Water and Power, its directors, officers, elected and appointed officials, employees, agents and representatives are added as Additional Insured and this insurance is primary, per CGD2460805 attached.

As respects General Liability coverage, a Waiver of Subrogation is hereby included per CGD3161111 attached.

As respects Automobile Liability coverage, County of Riverside, its Agencies, Special Districts and Departments, their respective director, officers, Board of Supervisors, elected and appointed officials, employees, agents, and representatives & The City of Corona Department of Water and Power, its directors, officers, elected and appointed officials, employees, agents and representatives are added as Additional Insured, per CAT3530215 attached.

As respects Workers' Compensation coverage, a Waiver of Subrogation is hereby included per WC040306 attached.

**THIS ENDORSEMENT CHANGES THE POLICY. PLEASE READ IT CAREFULLY****BLANKET ADDITIONAL INSURED  
(CONTRACTORS)**

This endorsement modifies insurance provided under the following:

**COMMERCIAL GENERAL LIABILITY COVERAGE PART**

1. WHO IS AN INSURED – (Section II) is amended to include any person or organization that you agree in a "written contract requiring insurance" to include as an additional insured on this Coverage Part, but:
  - a) Only with respect to liability for "bodily injury", "property damage" or "personal injury"; and
  - b) If, and only to the extent that, the Injury or damage is caused by acts or omissions of you or your subcontractor in the performance of "your work" to which the "written contract requiring insurance" applies. The person or organization does not qualify as an additional insured with respect to the independent acts or omissions of such person or organization.
2. The insurance provided to the additional insured by this endorsement is limited as follows:
  - a) In the event that the Limits of Insurance of this Coverage Part shown in the Declarations exceed the limits of liability required by the "written contract requiring insurance", the insurance provided to the additional insured shall be limited to the limits of liability required by that "written contract requiring insurance". This endorsement shall not increase the limits of insurance described in Section III – Limits Of Insurance.
  - b) The insurance provided to the additional insured does not apply to "bodily injury", "property damage" or "personal injury" arising out of the rendering of, or failure to render, any professional architectural, engineering or surveying services, including:
    - I. The preparing, approving, or failing to prepare or approve, maps, shop drawings, opinions, reports, surveys, field orders or change orders, or the preparing, approving, or failing to prepare or approve, drawings and specifications; and
    - II. Supervisory, inspection, architectural or engineering activities.
- c) The insurance provided to the additional insured does not apply to "bodily injury" or "property damage" caused by "your work" and included in the "products-completed operations hazard" unless the "written contract requiring insurance" specifically requires you to provide such coverage for that additional insured, and then the insurance provided to the additional insured applies only to such "bodily injury" or "property damage" that occurs before the end of the period of time for which the "written contract requiring insurance" requires you to provide such coverage or the end of the policy period, whichever is earlier.
3. The insurance provided to the additional insured by this endorsement is excess over any valid and collectible "other insurance", whether primary, excess, contingent or on any other basis, that is available to the additional insured for a loss we cover under this endorsement. However, if the "written contract requiring insurance" specifically requires that this insurance apply on a primary basis or a primary and non-contributory basis, this insurance is primary to "other insurance" available to the additional insured which covers that person or organization as a named insured for such loss, and we will not share with that "other insurance". But the insurance provided to the additional insured by this endorsement still is excess over any valid and collectible "other insurance", whether primary, excess, contingent or on any other basis, that is available to the additional insured when that person or organization is an additional insured under such "other insurance".
4. As a condition of coverage provided to the additional insured by this endorsement:
  - a) The additional insured must give us written notice as soon as practicable of an "occurrence" or an offense which may result in a claim. To the extent possible, such notice should include:

COMMERCIAL GENERAL LIABILITY

- i. How, when and where the "occurrence" or offense took place;
  - ii. The names and addresses of any injured persons and witnesses; and
  - iii. The nature and location of any injury or damage arising out of the "occurrence" or offense.
- b) If a claim is made or "suit" is brought against the additional insured, the additional insured must:
- i. Immediately record the specifics of the claim or "suit" and the date received; and
  - ii. Notify us as soon as practicable.

The additional insured must see to it that we receive written notice of the claim or "suit" as soon as practicable.

- c) The additional insured must immediately send us copies of all legal papers received in connection with the claim or "suit", cooperate with us in the investigation or settlement of the claim or defense against the "suit", and otherwise comply with all policy conditions.
- d) The additional insured must tender the defense and indemnity of any claim or "suit" to

any provider of "other insurance" which would cover the additional insured for a loss we cover under this endorsement. However, this condition does not affect whether the insurance provided to the additional insured by this endorsement is primary to "other insurance" available to the additional insured which covers that person or organization as a named insured as described in paragraph 3. above.

5. The following definition is added to SECTION V. – DEFINITIONS:

"Written contract requiring insurance" means that part of any written contract or agreement under which you are required to include a person or organization as an additional insured on this Coverage Part, provided that the "bodily injury" and "property damage" occurs and the "personal injury" is caused by an offense committed:

- a. After the signing and execution of the contract or agreement by you;
- b. While that part of the contract or agreement is in effect; and
- c. Before the end of the policy period.

Signed \_\_\_\_\_

*Cal Sestrum*

**THIS ENDORSEMENT CHANGES THE POLICY. PLEASE READ IT CAREFULLY.**

## **BUSINESS AUTO EXTENSION ENDORSEMENT**

This endorsement modifies insurance provided under the following:

### **BUSINESS AUTO COVERAGE FORM**

**GENERAL DESCRIPTION OF COVERAGE** – This endorsement broadens coverage. However, coverage for any injury, damage or medical expenses described in any of the provisions of this endorsement may be excluded or limited by another endorsement to the Coverage Part, and these coverage broadening provisions do not apply to the extent that coverage is excluded or limited by such an endorsement. The following listing is a general coverage description only. Limitations and exclusions may apply to these coverages. Read all the provisions of this endorsement and the rest of your policy carefully to determine rights, duties, and what is and is not covered.

- A. BROAD FORM NAMED INSURED
- B. BLANKET ADDITIONAL INSURED
- C. EMPLOYEE HIRED AUTO
- D. EMPLOYEES AS INSURED
- E. SUPPLEMENTARY PAYMENTS – INCREASED LIMITS
- F. HIRED AUTO – LIMITED WORLDWIDE COVERAGE – INDEMNITY BASIS
- G. WAIVER OF DEDUCTIBLE – GLASS
- H. HIRED AUTO PHYSICAL DAMAGE – LOSS OF USE – INCREASED LIMIT
- I. PHYSICAL DAMAGE – TRANSPORTATION EXPENSES – INCREASED LIMIT
- J. PERSONAL PROPERTY
- K. AIRBAGS
- L. NOTICE AND KNOWLEDGE OF ACCIDENT OR LOSS
- M. BLANKET WAIVER OF SUBROGATION
- N. UNINTENTIONAL ERRORS OR OMISSIONS

### **PROVISIONS**

#### **A. BROAD FORM NAMED INSURED**

The following is added to Paragraph A.1., Who Is An Insured, of SECTION II – COVERED AUTOS LIABILITY COVERAGE:

Any organization you newly acquire or form during the policy period over which you maintain 50% or more ownership interest and that is not separately insured for Business Auto Coverage. Coverage under this provision is afforded only until the 180th day after you acquire or form the organization or the end of the policy period, whichever is earlier.

#### **B. BLANKET ADDITIONAL INSURED**

The following is added to Paragraph c. in A.1., Who Is An Insured, of SECTION II – COVERED AUTOS LIABILITY COVERAGE:

Any person or organization who is required under a written contract or agreement between you and that person or organization, that is signed and executed by you before the "bodily injury" or "property damage" occurs and that is in effect during the policy period, to be named as an additional insured is an "insured" for Covered Autos Liability Coverage, but only for damages to which

this insurance applies and only to the extent that person or organization qualifies as an "insured" under the Who Is An Insured provision contained in Section II.

#### **C. EMPLOYEE HIRED AUTO**

1. The following is added to Paragraph A.1., Who Is An Insured, of SECTION II – COVERED AUTOS LIABILITY COVERAGE:

An "employee" of yours is an "insured" while operating an "auto" hired or rented under a contract or agreement in an "employee's" name, with your permission, while performing duties related to the conduct of your business.

2. The following replaces Paragraph b. in B.5., Other Insurance, of SECTION IV – BUSINESS AUTO CONDITIONS:

b. For Hired Auto Physical Damage Coverage, the following are deemed to be covered "autos" you own:

- (1) Any covered "auto" you lease, hire, rent or borrow; and
- (2) Any covered "auto" hired or rented by your "employee" under a contract in an "employee's" name, with your



## COMMERCIAL AUTO

permission, while performing duties related to the conduct of your business.

However, any "auto" that is leased, hired, rented or borrowed with a driver is not a covered "auto".

### D. EMPLOYEES AS INSURED

The following is added to Paragraph A.1., Who Is An Insured, of SECTION II – COVERED AUTOS LIABILITY COVERAGE:

Any "employee" of yours is an "insured" while using a covered "auto" you don't own, hire or borrow in your business or your personal affairs.

### E. SUPPLEMENTARY PAYMENTS – INCREASED LIMITS

1. The following replaces Paragraph A.2.a.(2), of SECTION II – COVERED AUTOS LIABILITY COVERAGE:

(2) Up to \$3,000 for cost of bail bonds (including bonds for related traffic law violations) required because of an "accident" we cover. We do not have to furnish these bonds.

2. The following replaces Paragraph A.2.a.(4), of SECTION II – COVERED AUTOS LIABILITY COVERAGE:

(4) All reasonable expenses incurred by the "insured" at our request, including actual loss of earnings up to \$500 a day because of time off from work.

### F. HIRED AUTO – LIMITED WORLDWIDE COVERAGE – INDEMNITY BASIS

The following replaces Subparagraph (5) in Paragraph B.7., Policy Period, Coverage Territory, of SECTION IV – BUSINESS AUTO CONDITIONS:

(5) Anywhere in the world, except any country or jurisdiction while any trade sanction, embargo, or similar regulation imposed by the United States of America applies to and prohibits the transaction of business with or within such country or jurisdiction, for Covered Autos Liability Coverage for any covered "auto" that you lease, hire, rent or borrow without a driver for a period of 30 days or less and that is not an "auto" you lease, hire, rent or borrow from any of your "employees", partners (if you are a partnership), members (if you are a limited liability company) or members of their households.

(a) With respect to any claim made or "suit" brought outside the United States of America, the territories and possessions of the United States of America, Puerto Rico and Canada:

(i) You must arrange to defend the "insured" against, and investigate or settle any such claim or "suit" and keep us advised of all proceedings and actions.

(ii) Neither you nor any other involved "insured" will make any settlement without our consent.

(iii) We may, at our discretion, participate in defending the "insured" against, or in the settlement of, any claim or "suit".

(iv) We will reimburse the "insured" for sums that the "insured" legally must pay as damages because of "bodily injury" or "property damage" to which this insurance applies, that the "insured" pays with our consent, but only up to the limit described in Paragraph C., Limits Of Insurance, of SECTION II – COVERED AUTOS LIABILITY COVERAGE.

(v) We will reimburse the "insured" for the reasonable expenses incurred with our consent for your investigation of such claims and your defense of the "insured" against any such "suit", but only up to and included within the limit described in Paragraph C., Limits Of Insurance, of SECTION II – COVERED AUTOS LIABILITY COVERAGE, and not in addition to such limit. Our duty to make such payments ends when we have used up the applicable limit of insurance in payments for damages, settlements or defense expenses.

(b) This insurance is excess over any valid and collectible other insurance available to the "insured" whether primary, excess, contingent or on any other basis.

(c) This insurance is not a substitute for required or compulsory insurance in any country outside the United States, its territories and possessions, Puerto Rico and Canada.

You agree to maintain all required or compulsory insurance in any such country up to the minimum limits required by local law. Your failure to comply with compulsory insurance requirements will not invalidate the coverage afforded by this policy, but we will only be liable to the same extent we would have been liable had you complied with the compulsory insurance requirements.

- (d) It is understood that we are not an admitted or authorized insurer outside the United States of America, its territories and possessions, Puerto Rico and Canada. We assume no responsibility for the furnishing of certificates of insurance, or for compliance in any way with the laws of other countries relating to insurance.

**G. WAIVER OF DEDUCTIBLE – GLASS**

The following is added to Paragraph D., **Deductible**, of SECTION III – **PHYSICAL DAMAGE COVERAGE**:

No deductible for a covered "auto" will apply to glass damage if the glass is repaired rather than replaced.

**H. HIRED AUTO PHYSICAL DAMAGE – LOSS OF USE – INCREASED LIMIT**

The following replaces the last sentence of Paragraph A.4.b., **Loss Of Use Expenses**, of SECTION III – **PHYSICAL DAMAGE COVERAGE**:

However, the most we will pay for any expenses for loss of use is \$65 per day, to a maximum of \$750 for any one "accident".

**I. PHYSICAL DAMAGE – TRANSPORTATION EXPENSES – INCREASED LIMIT**

The following replaces the first sentence in Paragraph A.4.a., **Transportation Expenses**, of SECTION III – **PHYSICAL DAMAGE COVERAGE**:

We will pay up to \$50 per day to a maximum of \$1,500 for temporary transportation expense incurred by you because of the total theft of a covered "auto" of the private passenger type.

**J. PERSONAL PROPERTY**

The following is added to Paragraph A.4., **Coverage Extensions**, of SECTION III – **PHYSICAL DAMAGE COVERAGE**:

**Personal Property**

We will pay up to \$400 for "loss" to wearing apparel and other personal property which is:

- (1) Owned by an "insured"; and

- (2) In or on your covered "auto".

This coverage applies only in the event of a total theft of your covered "auto".

No deductibles apply to this Personal Property coverage.

**K. AIRBAGS**

The following is added to Paragraph B.3., **Exclusions**, of SECTION III – **PHYSICAL DAMAGE COVERAGE**:

Exclusion 3.a. does not apply to "loss" to one or more airbags in a covered "auto" you own that inflate due to a cause other than a cause of "loss" set forth in Paragraphs A.1.b. and A.1.c., but only:

- a. If that "auto" is a covered "auto" for Comprehensive Coverage under this policy;
- b. The airbags are not covered under any warranty; and
- c. The airbags were not intentionally inflated.

We will pay up to a maximum of \$1,000 for any one "loss".

**L. NOTICE AND KNOWLEDGE OF ACCIDENT OR LOSS**

The following is added to Paragraph A.2.a., of SECTION IV – **BUSINESS AUTO CONDITIONS**:

Your duty to give us or our authorized representative prompt notice of the "accident" or "loss" applies only when the "accident" or "loss" is known to:

- (a) You (if you are an individual);
- (b) A partner (if you are a partnership);
- (c) A member (if you are a limited liability company);
- (d) An executive officer, director or insurance manager (if you are a corporation or other organization); or
- (e) Any "employee" authorized by you to give notice of the "accident" or "loss".

**M. BLANKET WAIVER OF SUBROGATION**

The following replaces Paragraph A.5., **Transfer Of Rights Of Recovery Against Others To Us**, of SECTION IV – **BUSINESS AUTO CONDITIONS**:

**5. Transfer Of Rights Of Recovery Against Others To Us**

We waive any right of recovery we may have against any person or organization to the extent required of you by a written contract signed and executed prior to any "accident" or "loss", provided that the "accident" or "loss" arises out of operations contemplated by

Signed Cal Sestruk

**WAIVER OF OUR RIGHT TO RECOVER FROM OTHERS ENDORSEMENT - CALIFORNIA**

We have the right to recover our payments from anyone liable for an injury covered by this policy. We will not enforce our right against the person or organization named in the Schedule. (This agreement applies only to the extent that you perform work under a written contract that requires you to obtain this agreement from us.)

You must maintain payroll records accurately segregating the remuneration of your employees while engaged in the work described in the Schedule.

The additional premium for this endorsement shall be 2 % of the California workers' compensation premium otherwise due on such remuneration.

**SCHEDULE**

**PERSON OR ORGANIZATION**

**JOB DESCRIPTION**

ANY PERSON OR ORGANIZATION FOR WHOM THE NAMED INSURED HAS AGREED BY WRITTEN CONTRACT TO FURNISH THIS WAIVER BLANKET WAIVER OF SUBROGATION

This endorsement changes the policy to which it is attached and is effective on the date issued unless otherwise stated. (The information below is required only when this endorsement is issued subsequent to preparation of the policy.)

Endorsement Effective 10/1/2014

Policy No. 7600005857141

Endorsement No.

Insured DBX Inc.

Premium \$ INCL.

Insurance Company EVEREST NATIONAL INSURANCE COMPANY

Countersigned By

-1998 by the Workers' Compensation Insurance Rating Bureau of California. All rights reserved. From the WCIRB's California Workers' Compensation Insurance Forms Manual - 1999.

INSURED COPY

by any ordinance, law or building code to include as an additional insured on this Coverage Part is an insured, but only with respect to liability for "bodily injury", "property damage", "personal injury" or "advertising injury" arising out of such operations.

The insurance provided to such state or political subdivision does not apply to:

- a. Any "bodily injury," "property damage," "personal injury" or "advertising injury" arising out of operations performed for that state or political subdivision; or
- b. Any "bodily injury" or "property damage" included in the "products-completed operations hazard".

#### **J. KNOWLEDGE AND NOTICE OF OCCURRENCE OR OFFENSE**

The following is added to Paragraph 2., **Duties In The Event of Occurrence, Offense, Claim or Suit**, of **SECTION IV – COMMERCIAL GENERAL LIABILITY CONDITIONS**:

- e. The following provisions apply to Paragraph a. above, but only for the purposes of the insurance provided under this Coverage Part to you or any insured listed in Paragraph 1. or 2. of Section II – Who Is An Insured:

- (1) Notice to us of such "occurrence" or offense must be given as soon as practicable only after the "occurrence" or offense is known by you (if you are an individual), any of your partners or members who is an individual (if you are a partnership or joint venture), any of your managers who is an individual (if you are a limited liability company), any of your "executive officers" or directors (if you are an organization other than a partnership, joint venture or limited liability company) or any "employee" authorized by you to give notice of an "occurrence" or offense.
- (2) If you are a partnership, joint venture or limited liability company, and none of your partners, joint venture members or managers are individuals, notice to us of such "occurrence" or offense must be given as soon as practicable only after the "occurrence" or offense is known by:
  - (a) Any individual who is:
    - (i) A partner or member of any partnership or joint venture;

- (ii) A manager of any limited liability company; or

- (iii) An executive officer or director of any other organization;

that is your partner, joint venture member or manager; or

- (b) Any "employee" authorized by such partnership, joint venture, limited liability company or other organization to give notice of an "occurrence" or offense.

- (3) Notice to us of such "occurrence" or of an offense will be deemed to be given as soon as practicable if it is given in good faith as soon as practicable to your workers' compensation insurer. This applies only if you subsequently give notice to us of the "occurrence" or offense as soon as practicable after any of the persons described in Paragraphs e. (1) or (2) above discovers that the "occurrence" or offense may result in sums to which the insurance provided under this Coverage Part may apply.

However, if this Coverage Part includes an endorsement that provides limited coverage for "bodily injury" or "property damage" or pollution costs arising out of a discharge, release or escape of "pollutants" which contains a requirement that the discharge, release or escape of "pollutants" must be reported to us within a specific number of days after its abrupt commencement, this Paragraph e. does not affect that requirement.

#### **K. UNINTENTIONAL OMISSION**

The following is added to Paragraph 6., **Representations**, of **SECTION IV – COMMERCIAL GENERAL LIABILITY CONDITIONS**:

The unintentional omission of, or unintentional error in, any information provided by you which we relied upon in issuing this policy will not prejudice your rights under this insurance. However, this provision does not affect our right to collect additional premium or to exercise our rights of cancellation or nonrenewal in accordance with applicable insurance laws or regulations.

#### **L. BLANKET WAIVER OF SUBROGATION**

The following is added to Paragraph 8., **Transfer Of Rights Of Recovery Against Others To Us**, of **SECTION IV – COMMERCIAL GENERAL LIABILITY CONDITIONS**:

## COMMERCIAL GENERAL LIABILITY

If the insured has agreed in a contract or agreement to waive that insured's right of recovery against any person or organization, we waive our right of recovery against such person or organization, but only for payments we make because of:

- a. "Bodily injury" or "property damage" that occurs; or
- b. "Personal injury" or "advertising injury" caused by an offense that is committed;

subsequent to the execution of that contract or agreement.

### M. AMENDED BODILY INJURY DEFINITION

The following replaces the definition of "bodily injury" in the **DEFINITIONS** Section:

3. "Bodily injury" means bodily injury, mental anguish, mental injury, shock, fright, disability, humiliation, sickness or disease sustained by a person, including death resulting from any of these at any time.

### N. CONTRACTUAL LIABILITY – RAILROADS

1. The following replaces Paragraph c. of the definition of "insured contract" in the **DEFINITIONS** Section:
  - c. Any easement or license agreement;
2. Paragraph f.(1) of the definition of "insured contract" in the **DEFINITIONS** Section is deleted.

ute by limits. Under this method, each insurer's share is based on the ratio of its applicable limit of insurance to the total applicable limits of insurance of all insurers.

#### 5. Premium Audit

- a. We will compute all premiums for this Coverage Part in accordance with our rules and rates.
- b. Premium shown in this Coverage Part as advance premium is a deposit premium only. At the close of each audit period we will compute the earned premium for that period and send notice to the first Named Insured. The due date for audit and retrospective premiums is the date shown as the due date on the bill. If the sum of the advance and audit premiums paid for the policy period is greater than the earned premium, we will return the excess to the first Named Insured.
- c. The first Named Insured must keep records of the information we need for premium computation, and send us copies at such times as we may request.

#### 6. Representations

By accepting this policy, you agree:

- a. The statements in the Declarations are accurate and complete;
- b. Those statements are based upon representations you made to us; and
- c. We have issued this policy in reliance upon your representations.

#### 7. Separation Of Insureds

Except with respect to the Limits of Insurance, and any rights or duties specifically assigned in this Coverage Part to the first Named Insured, this insurance applies:

- a. As if each Named Insured were the only Named Insured; and
- b. Separately to each insured against whom claim is made or "suit" is brought.

#### 8. Transfer Of Rights Of Recovery Against Others To Us

If the insured has rights to recover all or part of any payment we have made under this Coverage Part, those rights are transferred to us. The insured must do nothing after loss to impair them. At our request, the insured will bring "suit" or transfer those rights to us and help us enforce them.

#### 9. When We Do Not Renew

If we decide not to renew this Coverage Part, we will mail or deliver to the first Named Insured shown in the Declarations written notice of the nonrenewal not less than 30 days before the expiration date.

If notice is mailed, proof of mailing will be sufficient proof of notice.

#### SECTION V – DEFINITIONS

1. "Advertisement" means a notice that is broadcast or published to the general public or specific market segments about your goods, products or services for the purpose of attracting customers or supporters. For the purposes of this definition:
  - a. Notices that are published include material placed on the Internet or on similar electronic means of communication; and
  - b. Regarding web-sites, only that part of a web-site that is about your goods, products or services for the purposes of attracting customers or supporters is considered an advertisement.
2. "Auto" means a land motor vehicle, trailer or semitrailer designed for travel on public roads, including any attached machinery or equipment. But "auto" does not include "mobile equipment".
3. "Bodily injury" means bodily injury, sickness or disease sustained by a person, including death resulting from any of these at any time.
4. "Coverage territory" means:
  - a. The United States of America (including its territories and possessions), Puerto Rico and Canada;
  - b. International waters or airspace, but only if the injury or damage occurs in the course of travel or transportation between any places included in a. above; or
  - c. All other parts of the world if the injury or damage arises out of:
    - (1) Goods or products made or sold by you in the territory described in a. above;
    - (2) The activities of a person whose home is in the territory described in a. above, but is away for a short time on your business; or
    - (3) "Personal and advertising injury" offenses that take place through the Internet or similar electronic means of communication



**Prime Express<sup>SM</sup>  
Commercial Excess Liability Policy With CrisisResponse<sup>®</sup>**

**DECLARATIONS**

The company issuing this policy is indicated by an "X" in the box to the left of the company's name.

- |  |  |
|--|--|
| <input type="checkbox"/> American Home Assurance Company       | <input type="checkbox"/> Illinois National Insurance Company                                 |
| <input type="checkbox"/> AIG Assurance Company                 | <input checked="" type="checkbox"/> National Union Fire Insurance Company of Pittsburgh, Pa. |
| <input type="checkbox"/> AIG Property Casualty Company         | <input type="checkbox"/> New Hampshire Insurance Company                                     |
| <input type="checkbox"/> Commerce & Industry Insurance Company | <input type="checkbox"/> The Insurance Company of the State of Pennsylvania                  |
| <input type="checkbox"/> Granite State Insurance Company       |  |

(each of the above being a capital stock company)

**Administrative/Mailing Address: 175 Water Street, New York, NY 10038  
Telephone No. 212-458-5000**

**POLICY NUMBER: BE 060293302 RENEWAL OF: 021325008**

**ITEM 1. NAMED INSURED: DBX, INC. ✓**

**MAILING ADDRESS: 42024 AVENIDA ALVARADO A ✓  
TEMECULA, CA 92590-3405**

**ITEM 2. POLICY PERIOD: FROM: March 1, 2015 ✓ TO: March 1, 2016  
(At 12:01 A.M., standard time, at the address of the Named Insured stated above.)**

**ITEM 3. LIMITS OF INSURANCE**

The Limits of Insurance, subject to the terms of this policy, are:

- ✓ A. \$10,000,000 Each Occurrence
- B. \$10,000,000 General Aggregate (in accordance with Section IV. Limits of Insurance)
- C. \$10,000,000 Products-Completed Operations Aggregate (in accordance with Section IV. Limits of Insurance)
- D. \$250,000 CrisisResponse Sublimit of Insurance
- E. \$50,000 Excess Casualty CrisisFund Limit of Insurance

**ITEM 4. SCHEDULED UNDERLYING INSURANCE - See Schedule of Underlying Insurance**

**ITEM 5. PREMIUM AND PREMIUM COMPUTATION**

ESTIMATED TOTAL ANNUAL EXPOSURE  
RATES PER FLAT  
MINIMUM PREMIUM  
ADVANCE PREMIUM

**ITEM 6. THIS POLICY INCLUDES THESE ENDORSEMENTS AT INCEPTION DATE: SEE ATTACHED SCHEDULE**

**PRODUCER NAME: GARRETT/MOSIER INSURANCE SERVICES, INC.  
ADDRESS: 12 TRUMAN ST  
IRVINE, CA 92620-5742**

Christopher G. Kopser  
Authorized Representative or  
Countersignature (Where Applicable)

\_\_\_\_\_ Date

**Prime Express<sup>SM</sup>**  
**Commercial Excess Liability Policy With CrisisResponse<sup>®</sup>**

Various provisions in this policy restrict coverage. Read the entire policy carefully to determine rights, duties and what is and is not covered.

Throughout this policy the words "you" and "your" refer to the **Named Insured** shown in the Declarations and any other person or organization qualifying as a **Named Insured** under this policy. The words "we," "us" and "our" refer to the company providing this insurance.

The word **Insured** means any person or organization qualifying as such under Section VII. Definitions.

Except for headings, words that appear in bold print have special meaning. See Section VII. Definitions.

---

In consideration of the payment of the premium and in reliance upon the statements in the Declarations, we agree to provide coverage as follows:

**I. INSURING AGREEMENT - COMMERCIAL EXCESS LIABILITY**

A. We will pay on behalf of the **Insured** those sums in excess of the **Retained Limit** that the **Insured** becomes legally obligated to pay as damages by reason of liability imposed by law because of **Bodily Injury, Property Damage or Personal Injury and Advertising Injury** to which this insurance applies or because of **Bodily Injury or Property Damage** to which this insurance applies assumed by the **Insured** under an **Insured Contract**. Coverage under this policy will follow the terms, definitions, conditions and exclusions of **Scheduled Underlying Insurance**, subject to the **Policy Period**, Limits of Insurance, premium and all other terms, definitions, conditions and exclusions of this policy. Provided, however, that coverage provided by this policy will not be broader than the coverage provided by the policy listed in **Scheduled Underlying Insurance**.

The amount we will pay for damages is limited as described in Section IV. Limits of Insurance.

B. This policy applies, only if:

1. the **Bodily Injury or Property Damage** is caused by an **Occurrence** that takes place anywhere, and the **Bodily Injury or Property Damage** occurs during the **Policy Period**; and
2. the **Personal Injury and Advertising Injury** is caused by an **Occurrence** that takes place anywhere arising out of your business, but only if the **Occurrence** was committed during the **Policy Period**.

C. 1. This policy applies to **Bodily Injury or Property Damage**, only if prior to the **Policy Period**, no **Insured** listed under subparagraphs 2a., 2b., 2c. or 2e. of Paragraph N. of Section VII, no executive officer or director listed under subparagraph 2d. of Paragraph N. of Section VII. and no employee authorized by you to give or receive notice of an **Occurrence**, claim or **Suit**, knew that the **Bodily Injury or Property Damage** had occurred, in whole or in part. If such an **Insured**, or authorized employee knew, prior to the **Policy Period**, that the **Bodily Injury or Property Damage** had occurred, then any continuation, change or resumption of such **Bodily Injury or Property Damage** during or after the **Policy Period** will be deemed to have been known prior to the **Policy Period**.

2. **Bodily Injury or Property Damage** which occurs during the **Policy Period** and was not, prior to the **Policy Period**, known to have occurred by any **Insured** listed under subparagraphs 2a., 2b., 2c. or 2e. of Paragraph N. of Section VII., any executive officer or director listed under subparagraph 2d. of Paragraph N. of Section VII. or any employee authorized by you to give or receive notice of an **Occurrence** or claim, includes any continuation, change or resumption of that **Bodily Injury or Property Damage** after the end of the **Policy Period**.



- D. **Bodily Injury or Property Damage** will be deemed to have been known to have occurred at the earliest time when any **Insured** listed under subparagraphs 2a., 2b., 2c. or 2e. of Paragraph N. of Section VII, any executive officer or director listed under subparagraph 2d. of Paragraph N. of Section VII. or any employee who was authorized by you to give or receive notice of an **Occurrence**, claim or **Suit**:
1. reports all, or any part, of the **Bodily Injury or Property Damage** to us or any other insurer;
  2. receives a written or verbal demand or claim for damages because of the **Bodily Injury or Property Damage**; or
  3. becomes aware by any other means that **Bodily Injury or Property Damage** has occurred or has begun to occur.
- E. Damages because of **Bodily Injury** include damages claimed by any person or organization for care, loss of services or death resulting at any time from the **Bodily Injury**.
- F. If we are prevented by law or statute from paying damages covered by this policy on behalf of the **Insured**, then we will indemnify the **Insured** for those sums in excess of the **Retained Limit**.

## II. INSURING AGREEMENT - CRISISRESPONSE® AND EXCESS CASUALTY CRISISFUND®

### A. CrisisResponse

We will advance **CrisisResponse Costs** directly to third parties on behalf of the **Named Insured**, regardless of fault, arising from a **Crisis Management Event** first commencing during the **Policy Period**, up to the amount of the **CrisisResponse Sublimit of Insurance**.

### B. Excess Casualty CrisisFund

We will pay **Crisis Management Loss** on behalf of the **Named Insured** arising from a **Crisis Management Event** first commencing during the **Policy Period**, up to the amount of the **Excess Casualty CrisisFund Limit of Insurance**.

- C. A **Crisis Management Event** will first commence at the time during the **Policy Period** when a **Key Executive** first becomes aware of an **Occurrence** that gives rise to a **Crisis Management Event** and will end when we determine that a crisis no longer exists or when the **CrisisResponse Sublimit of Insurance** has been exhausted, whichever occurs first.
- D. There will be no **Retained Limit** applicable to **CrisisResponse Costs** or **Crisis Management Loss**.
- E. Any advancement of **CrisisResponse Costs** or payment of **Crisis Management Loss** that we make under the coverage provided by this Section II will not be a determination of our obligations under this policy, nor create any duty to defend any **Suit** under any other part of this policy.

## III. DEFENSE PROVISIONS

- A. We will have the right and duty to defend any **Suit** against the **Insured** that seeks damages for **Bodily Injury, Property Damage or Personal Injury and Advertising Injury** covered by this policy, even if the **Suit** is groundless, false or fraudulent when the total applicable limits of **Scheduled Underlying Insurance** have been exhausted by payment of **Loss** to which this policy applies and the total applicable limits of **Other Insurance** have been exhausted.

If we are prevented by law or statute from assuming the obligations specified under this provision, we will pay any expenses incurred with our consent.

- B. We will have no duty to defend the Insured against any Suit seeking damages for Bodily Injury, Property Damage or Personal Injury and Advertising Injury to which this insurance does not apply.
- C. When we assume the defense of any Suit against the Insured that seeks damages covered by this policy, we will:
  - 1. investigate, negotiate and settle the Suit as we deem expedient; and
  - 2. pay the following supplementary payments to the extent that such payments are not covered by Scheduled Underlying Insurance or any applicable Other Insurance:
    - a. premiums on bonds to release attachments for amounts not exceeding the applicable Limits of Insurance of this policy, but we are not obligated to apply for or furnish any such bond;
    - b. premiums on appeal bonds required by law to appeal a judgment in a Suit for amounts not exceeding the applicable Limits of Insurance of this policy, but we are not obligated to apply for or furnish any such bond;
    - c. all court costs taxed against the Insured in the Suit;
    - d. pre-judgment interest awarded against the Insured on that part of the judgment within the applicable Limits of Insurance of this policy we pay. If we make an offer to pay the applicable limit of insurance, we will not pay any pre-judgment interest accruing after we make such offer;
    - e. post-judgment interest that accrues after entry of judgment on that part of the judgment within the applicable Limits of Insurance of this policy we pay and before we have paid, offered to pay or deposited in court that part of the judgment that is within the applicable Limits of Insurance of this policy; and
    - f. the Insured's expenses incurred at our request or with our consent.
- D. Except as provided in Paragraph A above, we will have no duty to defend any Suit against the Insured. We will, however, have the right, but not the duty, to participate in the defense of any Suit and the investigation of any claim to which this policy may apply. If we exercise this right, we will do so at our own expense.
- E. We will not defend any Suit, or pay any attorney fees or litigation expenses including, without limitation, the expenses described in Paragraph C above that accrue after the applicable Limits of Insurance of this policy have been exhausted by the payment of Loss and we will have the right to withdraw from the further defense of such Suit by tendering control of said defense to the Insured.

**IV. LIMITS OF INSURANCE**

- A. The Limits of Insurance shown in Item 3 of the Declarations and the rules below state the most we will pay for all damages under this policy regardless of the number of:
  - 1. Insureds;
  - 2. claims made or Suits brought;
  - 3. persons or organizations making claims or bringing Suits; or
  - 4. coverages provided under this policy.
- B. The General Aggregate Limit stated in Item 3 of the Declarations is the most we will pay for all damages under this policy, except for:
  - 1. damages included within the Products-Completed Operations Hazard; and

2. damages because of **Bodily Injury or Property Damage** to which this policy applies, caused by an **Occurrence** and resulting from the ownership, maintenance or use of an **Auto** covered under **Scheduled Underlying Insurance**.
- C. The **Products-Completed Operations Aggregate Limit** stated in Item 3C of the **Declarations** is the most we will pay for all damages included in the **Products-Completed Operations Hazard**.
  - D. Subject to Paragraphs B and C above, the **Each Occurrence Limit** stated in Item 3A of the **Declarations** is the most we will pay for the sum of all damages arising out of any one **Occurrence**.
  - E. Subject to Paragraphs B and C above, the most we will pay for damages under this policy on behalf of any person or organization to whom you are obligated by written **Insured Contract** to provide insurance such as is afforded by this policy is the lesser of the **Limits of Insurance** shown in Item 3 of the **Declarations** or the minimum **Limits of Insurance** you agreed to procure in such written **Insured Contract**.
  - F. This policy applies only in excess of the **Retained Limit**. If however, a policy shown in the **Schedule of Underlying Insurance** forming a part of this policy has a limit of insurance:
    1. greater than the amount shown in such schedule, this policy will apply in excess of the greater amount of valid and collectible insurance; or
    2. less than the amount shown in such schedule, this policy will apply in excess of the amount shown in the **Schedule of Underlying Insurance** forming a part of this policy.
  - G. If the total applicable limits of **Scheduled Underlying Insurance** are reduced or exhausted by the payment of **Loss** to which this policy applies and the total applicable limits of applicable **Other Insurance** are reduced or exhausted, we will:
    1. in the event of reduction, pay excess of the remaining total applicable limits of **Scheduled Underlying Insurance** and any applicable **Other Insurance**; and
    2. in the event of exhaustion, continue in force as underlying insurance.
  - H. Expenses incurred to defend any **Suit** or to investigate any claim will be in addition to the applicable **Limits of Insurance** of this policy. Provided, however, that if such expenses reduce the applicable limits of **Scheduled Underlying Insurance**, then such expenses will reduce the applicable **Limits of Insurance** of this policy.
  - I. The **CrisisResponse Sublimit of Insurance** is the most we will pay for all **CrisisResponse Costs** under this policy, regardless of the number of **Crisis Management Events** first commencing during the **Policy Period**. This **CrisisResponse Sublimit of Insurance** will be part of, not in addition to, the applicable **Limit of Insurance**.
  - J. The **Excess Casualty CrisisFund Limit of Insurance** is the most we will pay for all **Crisis Management Loss** under this policy, regardless of the number of **Crisis Management Events** first commencing during the **Policy Period**. This **Excess Casualty CrisisFund Limit of Insurance** will be in addition to the applicable **Limit of Insurance**.
  - K. We will have no obligation to advance **CrisisResponse Costs** when we determine that a **Crisis Management Event** has ended or when the **CrisisResponse Sublimit of Insurance** has been exhausted, whichever occurs first.
  - L. The **Limits of Insurance** of this policy apply separately to each consecutive annual period and to any remaining period of less than twelve (12) months, beginning with the inception date of the **Policy Period** shown in the **Declarations**, unless the **Policy Period** is extended after issuance for an additional period of less than twelve (12) months. In that case, the additional period will be deemed part of the last preceding period for purposes of determining the **Limits of Insurance** of this policy.

M. We will not make any payment under this policy unless and until the total applicable limits of **Scheduled Underlying Insurance** have been exhausted by the payment of **Loss** to which this policy applies and any applicable **Other Insurance** have been exhausted by the payment of **Loss**.

When the amount of **Loss** has been determined by an agreed settlement or a final judgment, we will promptly pay on behalf of the **Insured** the amount of such **Loss** falling within the terms of this policy. An agreed settlement means a settlement and release of liability signed by us, the **Insured** and the claimant or the claimant's legal representative.

## V. EXCLUSIONS

### A. Aircraft and Watercraft

This insurance does not apply to **Bodily Injury** or **Property Damage** arising out of the ownership, maintenance, use or entrustment to others of any aircraft or watercraft owned or operated by or rented or loaned to any **Insured**. Use includes operation and loading and unloading.

This exclusion applies even if the claims against any **Insured** allege negligence or other wrongdoing in the supervision, hiring, employment, training or monitoring of others by that **Insured**, if the **Occurrence** which caused the **Bodily Injury** or **Property Damage** involved the ownership, maintenance, use or entrustment to others of any aircraft or watercraft that is owned or operated by or rented or loaned to any **Insured**.

This exclusion does not apply to a watercraft you do not own that is:

1. less than 26 feet long; and
2. not being used to carry persons or property for a charge.

### B. Asbestos

This insurance does not apply to any liability arising out of:

1. the manufacture of, mining of, use of, sale of, installation of, removal of, distribution of or exposure to asbestos, asbestos containing products or materials, asbestos fibers or asbestos dust;
2. any obligation of the **Insured** to indemnify any party because of damages arising out of the manufacture of, mining of, use of, sale of, installation of, removal of, distribution of or exposure to asbestos, asbestos products, asbestos fibers or asbestos dust; or
3. any obligation to defend any **Suit** or claim against the **Insured** that seeks damages if such **Suit** or claim arises as the result of the manufacture of, mining of, use of, sale of, installation of, removal of, distribution of or exposure to asbestos, asbestos products, asbestos fibers or asbestos dust.

### C. Contractors

This insurance does not apply to:

1. **Property Damage** to any property or equipment leased by the **Insured**;
2. **Property Damage** to property being installed, erected or worked upon by the **Insured** or by any agents or subcontractors of the **Insured**; or
3. any liability arising out of any project insured under a "wrap-up" or any similar rating plan.

4. **Bodily Injury or Property Damage** included within the **Products-Completed Operations Hazard** and arising in whole or in part out of the design, manufacture, construction, fabrication, preparation, installation, application, maintenance or repair, including remodeling, service, correction, or replacement of an Exterior Insulation and Finish System (EIFS), synthetic stucco, or any part thereof, including the application or use of paints, conditioners, primers, accessories, flashings, coatings, caulking or sealants in connection with such product.

#### **D. Contractual Liability**

This insurance does not apply to any liability for which the Insured is obligated to pay damages by reason of the assumption of liability in a contract or agreement. This exclusion does not apply to liability for damages:

1. that the Insured would have in the absence of a contract or agreement; or
2. assumed in an Insured Contract, provided **Bodily Injury or Property Damage** occurs subsequent to the execution and prior to the termination of the Insured Contract. Solely for the purposes of liability assumed in an Insured Contract, reasonable attorney fees and necessary litigation expenses incurred by or for a party other than an Insured are deemed to be damages because of **Bodily Injury or Property Damage** and included in the Limits of Insurance of this policy, provided:
  - a. liability to such party for, or for the cost of, that party's defense has also been assumed in the same Insured Contract; and
  - b. such attorney fees and litigation expenses are for the defense of that party against a civil or alternative dispute resolution proceeding in which damages to which this policy applies are alleged.

#### **E. Cross Suits**

This insurance does not apply to **Bodily Injury, Property Damage, or Personal Injury and Advertising Injury** to a **Named Insured** that is caused, in whole or in part, by any other **Named Insured**.

#### **F. Damage to Impaired Property or Property Not Physically Injured**

This insurance does not apply to **Property Damage to Impaired Property** or property that has not been physically injured, arising out of:

1. a defect, deficiency, inadequacy or dangerous condition in **Your Product or Your Work**; or
2. a delay or failure by you or anyone acting on your behalf to perform a contract or agreement in accordance with its terms.

This exclusion does not apply to the loss of use of other property arising out of sudden and accidental physical injury to **Your Product or Your Work** after it has been put to its intended use.

#### **G. Damage to Property**

This insurance does not apply to **Property Damage** to:

1. property you own, rent, or occupy, including any costs or expenses incurred by you, or any other person, organization or entity, for repair, replacement, enhancement, restoration or maintenance of such property for any reason, including prevention of injury to a person or damage to another's property;
2. premises you sell, give away or abandon, if the **Property Damage** arises out of any part of those premises;



- Company Profile
- Company Search
- Company Information
- Old Company Names
- Agent for Service
- Reference Information
- NAIC Group List
- Lines of Business
- Workers' Compensation
- Complaint and Request for Action/Appeals
- Contact Information
- Financial Statements PDF's
- Annual Statements
- Quarterly Statements
- Company Complaint
- Company Performance & Comparison Data
- Company Enforcement Action
- Composite Complaints Studies
- Additional Info
- Find A Company Representative In Your Area
- View Financial Disclaimer

**COMPANY PROFILE**

**Company Information**

**TRAVELERS INDEMNITY COMPANY OF CONNECTICUT (THE)**  
**ONE TOWER SQUARE**  
**HARTFORD, CT 06183-1190**

Old Company Names	Effective Date
EQUITABLE FIRE AND MARINE INSURANCE COMPANY	10/08/1971
TRAVELERS INDEMNITY COMPANY OF RHODE ISLAND (THE)	09/12/1995

**Agent For Service**

KARISSA LOWRY  
 C/O CORPORATION SERVICE COMPANY  
 2710 GATEWAY OAKS DRIVE, SUITE 150N  
 SACRAMENTO CA 95833

**Reference Information**

NAIC #:	25682
California Company ID #:	0056-2
Date Authorized in California:	06/28/1890
License Status:	UNLIMITED-NORMAL
Company Type:	Property & Casualty
State of Domicile:	CONNECTICUT

[back to top](#)

**NAIC Group List**

NAIC Group #: **3548** Travelers Grp

**Lines Of Business**

The company is authorized to transact business within these lines of insurance. For an explanation of any of these terms, please refer to the [glossary](#).

- AIRCRAFT
- AUTOMOBILE
- BOILER AND MACHINERY
- BURGLARY
- COMMON CARRIER LIABILITY
- DISABILITY
- FIRE
- LEGAL INSURANCE
- LIABILITY
- MARINE
- MISCELLANEOUS
- PLATE GLASS
- SPRINKLER
- SURETY
- TEAM AND VEHICLE
- WORKERS' COMPENSATION

[back to top](#)



- Company Profile
- Company Search
- Company Information
- Old Company Names
- Agent for Service
- Reference Information
- NAIC Group List
- Lines of Business
- Workers' Compensation Complaint and Request for Action/Appeals Contact Information
- Financial Statements PDF's
  - Annual Statements
  - Quarterly Statements
- Company Complaint
  - Company Performance & Comparison Data
  - Company Enforcement Action
  - Composite Complaints Studies
- Additional Info
  - Find A Company Representative In Your Area
  - View Financial Disclaimer

**COMPANY PROFILE**

**Company Information**

**NATIONAL UNION FIRE INSURANCE COMPANY OF PITTSBURGH, PA**  
**180 MAIDEN LANE**  
**NEW YORK, NY 10038**  
**800-551-0824**

**Old Company Names** **Effective Date**

**Agent For Service**

KARISSA LOWRY  
 C/O CORPORATION SERVICE COMPANY  
 2710 GATEWAY OAKS DRIVE, SUITE 150N  
 SACRAMENTO CA 95833

**Reference Information**

NAIC #:	19445
California Company ID #:	0131-3
Date Authorized in California:	11/28/1902
License Status:	UNLIMITED-NORMAL
Company Type:	Property & Casualty
State of Domicile:	PENNSYLVANIA

[back to top](#)

**NAIC Group List**

NAIC Group #: 0012 AMERICAN INTRNL GRP

**Lines Of Business**

The company is authorized to transact business within these lines of insurance. For an explanation of any of these terms, please refer to the [glossary](#).

- AIRCRAFT
- AUTOMOBILE
- BOILER AND MACHINERY
- BURGLARY
- COMMON CARRIER LIABILITY
- DISABILITY
- FIRE
- LIABILITY
- MARINE
- MISCELLANEOUS
- PLATE GLASS
- SPRINKLER
- SURETY
- TEAM AND VEHICLE
- WORKERS' COMPENSATION

[back to top](#)



- Company Profile
- Company Search
- Company Information
- Old Company Names
- Agent for Service
- Reference Information
- NAIC Group List
- Lines of Business
- Workers' Compensation
- Complaint and Request for Action/Appeals
- Contact Information
- Financial Statements PDF's
- Annual Statements
- Quarterly Statements
- Company Complaint
- Company Performance & Comparison Data
- Company Enforcement Action
- Composite Complaints Studies
- Additional Info
- Find A Company Representative In Your Area
- View Financial Disclaimer

## COMPANY PROFILE

### Company Information

#### EVEREST NATIONAL INSURANCE COMPANY

477 MARTINSVILLE ROAD  
LIBERTY CORNER, NJ 07938-0830  
800-438-4375

Old Company Names	Effective Date
DRYDEN GUARANTY INSURANCE COMPANY	10/20/1993
PRUDENTIAL NATIONAL INSURANCE COMPANY	06/17/1996

#### Agent For Service

NANCY CARAVACA  
1111 BROADWAY  
SUITE 2050  
OAKLAND CA 94607

#### Reference Information

NAIC #:	10120
California Company ID #:	3138-5
Date Authorized in California:	03/02/1988
License Status:	UNLIMITED-NORMAL
Company Type:	Property & Casualty
State of Domicile:	DELAWARE

[back to top](#)

#### NAIC Group List

NAIC Group #: **1120** EVEREST REIN HOL INC

#### Lines Of Business

The company is authorized to transact business within these lines of insurance. For an explanation of any of these terms, please refer to the [glossary](#).

AIRCRAFT  
AUTOMOBILE  
BOILER AND MACHINERY  
BURGLARY  
COMMON CARRIER LIABILITY  
FIRE  
LIABILITY  
MARINE  
MISCELLANEOUS  
PLATE GLASS  
SPRINKLER  
SURETY  
TEAM AND VEHICLE  
WORKERS' COMPENSATION

[back to top](#)



## Bid

Date: 7/7/15

To: County of Riverside, hereafter called "County";

Bidder: DBX Inc  
(hereafter called "Contractor")

The undersigned, Contractor, having carefully examined the site and the Contract Documents for the construction of **Serfas Club Drive and Monterey Peninsula Drive, Traffic Signal and Lighting Project, In the Community of Coronita, Project No. C5-0073**, hereby proposes to construct the work in accordance with the Contract Documents, including **Addenda Number(s)** 1 (Fill in addenda numbers if addenda have been issued.) for the amount stated in this Bid.

By submitting this Bid, Contractor agrees with County:

1. That unless withdrawn in person by Contractor or some person authorized in writing by Contractor (not by telephone or facsimile) before the time specified in the Notice Inviting Bids for the public opening of bids, this Bid constitutes an irrevocable offer for 90 calendar days after that date.
2. County has the right to reject any or all Bids and to waive any irregularities or informalities contained in a Bid.
3. To execute the Contract and deliver the Performance Bond, Payment Bond and Insurance Certificate with endorsements, that comply with the requirements set forth in the Instruction to Bidders and General Conditions, within ten (10) business days of the date of the Notice of Acceptance of Bid and Intent to Award as issued by the County.
4. That the contract shall be awarded upon a resolution or minute order to that effect duly adopted by the governing body of County; and that execution of the Contract shall constitute a written memorial thereof.
5. To submit to the County such information as County may require determining whether a particular Bid is the lowest responsible bid submitted.
6. That the accompanying Bid Bond, certified check or cashier's check is in an amount not less than 10% of the total bid submitted and constitutes a guarantee that if awarded the contract, Contractor will execute the Contract and deliver the required bonds within ten (10) business days after notice of award. If Contractor fails to execute and deliver said documents, the bond or check is to be charged with the costs of the resultant damages to the County, including but not limited to: publication costs, the difference in money between the amount bid and the amount in excess of the bid which it costs County to do or cause to be done for the work involved, lease and rental costs, additional salaries and overhead, increased interest and costs of funding the project, attorney expense, additional engineering and architectural expense and cost of maintaining or constructing alternate facilities occasioned by the failure to execute and deliver said documents.
7. By signing this Bid the Contractor certifies that the representations made therein are made under penalty of perjury.

**Serfas Club Drive and Monterey Peninsula Drive  
Traffic Signal and Lighting Project  
In the Community of Coronita  
Project No. C5-0073**

ISSUED BY ADDENDUM No. 1  
ATTACHMENT "A"

**REVISED PROPOSAL**

ITEM No.	ITEM CODE	ITEM	UNIT	ESTIMATED QUANTITY	ITEM PRICE (IN FIGURES)	TOTAL (IN FIGURES)
1	130200	PREPARE WATER POLLUTION CONTROL PROGRAM	LS	1	900.00	900.00
2	120100	TRAFFIC CONTROL SYSTEM	LS	1	15000.00	15000.00
3	170101	DEVELOP WATER SUPPLY	LS	1	1000.00	1000.00
4	066100	DUST CONTROL	LS	1	3500.00	3500.00
5	160101	CLEARING AND GRUBBING	LS	1	4000.00	4000.00
6	190101	ROADWAY EXCAVATION	CY	50	248.00	12,400.00
7	153103	COLD PLANE ASPHALT CONCRETE PAVEMENT	SQYD	675	11.00	7,425.00
8	390130	HOT MIX ASPHALT	TON	150	225.00	33,750.00
9	017316	MINOR CONCRETE (CURB RAMP) (CRS 403 - CASE B)	EA	4	3200.00	12,800.00
10	017317	MINOR CONCRETE (CROSS-GUTTER AND SPANDREL)	SQFT	1,700	9.00	15,300.00
11	000001	ITEM DELETED BY ADDENDUM	---	---	---	---
12	731521	MINOR CONCRETE (SIDEWALK)	SQFT	100	18.44	1,844.00
13	017305	MINOR CONCRETE (CURB AND GUTTER) (CRS 201)	LF	40	36.00	1,440.00
14	513553	RETAINING WALL (MASONRY WALL) [PER CONSTRUCTION NOTE 9]	LF	50	207.00	10,350.00
14.A	513553	RETAINING WALL (MASONRY WALL) [PER CONSTRUCTION NOTE 13]	LF	30	258.00	7,740.00
14.B	839514	HAND RAILING [PER APWA STD 606-3, TYPE B]	LF	60	50.00	3,000.00
15	000003	REPLACE DAMAGED PLANTS/SOD	LS	1	2500.00	2,500.00
16	860201	SIGNAL AND LIGHTING	LS	1	216,531.00	216,531.00
17	150710	REMOVE TRAFFIC STRIPE	LF	300	0.60	180.00
18	150715	REMOVE THERMOPLASTIC PAVEMENT MARKING	SQFT	600	2.90	1,740.00
19	840656	PAINT TRAFFIC STRIPE (2-COAT)	LF	8,300	0.25	2,075.00
20	840515	THERMOPLASTIC PAVEMENT MARKING	SQFT	550	4.30	2,365.00
21	850111	PAVEMENT MARKER (RETROREFLECTIVE)	EA	210	2.90	609.00
22	566011	ROADSIDE SIGN - ONE POST	EA	2	272.00	544.00
23	150742	REMOVE (AND SALVAGE) EXISTING SIGN (AND POST)	EA	11	63.00	693.00
24	015602	FUNDING AWARENESS SIGN	EA	2	1200.00	2,400.00
25	010602	MISCELLANEOUS WORK (AS DIRECTED)	FA	1	30,000.00	30,000.00
26	019901	DE-MOBILIZATION	LS	1	10,000.00	10,000.00

PROJECT TOTAL: Four hundred thousand eightysix dollars \$400,086.00  
ITEMS 1-26 "WORDS" and zero cents

## Bidder Data and Signature

Name of Bidder: DBX, Inc

Type of organization: Corporation

Person(s) authorized to sign for Bidder: Jim Perry, President + Sec/Treas.  
James C. Perry, Vice President

Note:

If Bidder is a **Corporation**, state legal name of Corporation and also names of the president, vice-president, secretary, treasurer and manager thereof.

If Bidder is a **Co-Partnership**, state true name of firm and also names of all individual co-partners composing firm.

If Bidder is a sole proprietorship or an **Individual**, state first and last name(s) in full.

If Bid is signed by an agent other than an owner, partner or corporate officer, Bid shall be accompanied by a power-of-attorney.

Business Street Address: 42024 Avenida Alvarado, suite A  
(Please include business address even if P.O. Box is used.)

Business City, State, Zip Code: Temecula, CA 92590

P.O. Box- Number: \_\_\_\_\_

P.O. Box- City, State, Zip Code: \_\_\_\_\_

Phone: (951) 296-9909

Facsimile: (951) 296-9978

E-mail: dbxinc@hotmail.com

Contractor's license number: 240547

License Classification(s): A + C-10

Expiration date: 7/31/15

Department of Industrial Relations Registration Number: 1000004242

**Bidder Data and Signature (continued)**

Accompanying this Bid is a certified check, cashier check or bid bond in an amount equal to at least ten (10) percent of the total bid for:

**Serfas Club Drive and Monterey Peninsula Drive  
Traffic Signal and Lighting Project  
In the Community of Coronita  
Project No. C5-0073**

By my signature on this Bid, I certify, under penalty of perjury under the laws of the State of California, that all the information on this form is true and correct.

IN WITNESS WHERE OF Bidder/Contractor executed this Bid as of the date set forth on page **B1** of this Bid.

**Signature:**

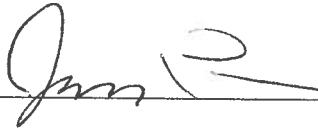

Name (printed):

Jim Perry

Title:

President

“Contractor”

### Subcontractor List

Bidder/Contractor submits the following complete list of each Subcontractor who will perform work, labor or render service in or about the construction in an amount in excess of 1/2 of 1% of the total bid or \$10,000 whichever is greater.

Check box on right side of row if any construction item, for the listed Subcontractor, is partial work. If partial work is to be performed within a certain construction item or trade, the Bidder/Contractor shall specify the portion(s) of the work to be performed by the different subcontractors or Bidder/Contractor will be subject to provisions of Public Contract Code Section 4106.

Name of Bidder (Prime/General Contractor): DBX, Inc.

	Subcontractor Name	License Number	DIR Registration Number	Business Address (City, State)	Construction Item(s) [Item Number and Description]	Check if Partial Work
1.	Orange County Striping Service, Inc	346095	100005547	183 N. Pixley Orange, CA	17, 18, 19, 20, 21, 22, 23 remove striping	<input type="checkbox"/>
2.					paint striping remove therm install thermo roadsigns	<input type="checkbox"/>
3.	Her-Con Construction Services, Inc	945955	1000012689	7585. Hollenbeck Covina, CA	5, 6, 7, 8, 9, 10, 12, 13, 14, 14A, 14B clearing, grubbing	<input type="checkbox"/>
4.					roadway exc, cold plane. HMA, minor concrete retaining wall,	<input type="checkbox"/>
5.					hand railing	<input type="checkbox"/>
6.						<input type="checkbox"/>
7.						<input type="checkbox"/>

(If applicable, check box.)  
Additional information for Subcontractor List is attached to this Bid. (A copy of this form may be attached with additional Subcontractor information.)

Percent of work to be performed by Subcontractors: 28 %

Note: A minimum of 50% of the work is required to be performed by the prime/general Contractor.

## Non-Collusion Declaration

To be executed by bidder and submitted with bid.  
(Title 23 United States Code Section 112 and Public Contract Code Section 7106)

The undersigned declares:

I am the President (Title) of DBX, Inc (Company),  
the party making the foregoing bid.

The bid is not made in the interest of, or on behalf of, any undisclosed person, partnership, company, association, organization, or corporation. The bid is genuine and not collusive or sham. The bidder has not directly or indirectly induced or solicited any other bidder to put in a false or sham bid. The bidder has not directly or indirectly colluded, conspired, connived, or agreed with any bidder or anyone else to put in a sham bid, or that anyone shall refrain from bidding. The bidder has not in any manner, directly or indirectly, sought by agreement, communication, or conference with anyone to fix the bid price of the bidder or any other bidder, or to fix any overhead, profit, or cost element of the bid price, or of that of any other bidder.

All statements contained in the bid are true. The bidder has not, directly or indirectly, submitted his or her bid price of any breakdown thereof, or the contents thereof, or divulged information or data relative thereto, to any corporation, partnership, company, association, organization, bid depository, or to any member or agent thereof to effectuate a collusive or sham bid, and has not paid, and will not pay, any person or entity for such purpose.

Any person executing this declaration on behalf of a bidder that is a corporation, partnership, joint venture, limited liability company, limited liability partnership, or any other entity, hereby represents that he or she has full power to execute, and does execute, this declaration on behalf of the bidder.

I declare under penalty of perjury under the applicable laws that the foregoing is true and correct and that this declaration is executed on

July (Month) 7 (Day) of 2015 (Year),

at temecula (City), CA (State).

Signature of Declarant: 

Printed name of Declarant: Jim Perry

Name of Bidder (Company): DBX, Inc

Title or Office: President

Note: Notarization of signature required.

Check box if attachment is included.

**CALIFORNIA ALL-PURPOSE ACKNOWLEDGMENT**

**CIVIL CODE § 1189**

A notary public or other officer completing this certificate verifies only the identity of the individual who signed the document to which this certificate is attached, and not the truthfulness, accuracy, or validity of that document.

State of California )  
County of Riverside )

On 7/7/15 before me, Phyllissa Martz, Notary Public  
Date Here Insert Name and Title of the Officer

personally appeared Jim Perry  
Name(s) of Signer(s)

who proved to me on the basis of satisfactory evidence to be the person(s) whose name(s) is/are subscribed to the within instrument and acknowledged to me that he/she/they executed the same in his/her/their authorized capacity(ies), and that by his/her/their signature(s) on the instrument the person(s), or the entity upon behalf of which the person(s) acted, executed the instrument.

I certify under PENALTY OF PERJURY under the laws of the State of California that the foregoing paragraph is true and correct.

WITNESS my hand and official seal.

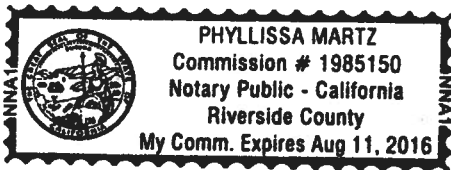

Signature Phyllissa Martz  
Signature of Notary Public

Place Notary Seal Above

**OPTIONAL**

Though this section is optional, completing this information can deter alteration of the document or fraudulent reattachment of this form to an unintended document.

**Description of Attached Document**

Title or Type of Document: \_\_\_\_\_ Document Date: \_\_\_\_\_

Number of Pages: \_\_\_\_\_ Signer(s) Other Than Named Above: \_\_\_\_\_

**Capacity(ies) Claimed by Signer(s)**

Signer's Name: Jim Perry

Corporate Officer — Title(s): President

Partner —  Limited  General

Individual  Attorney in Fact

Trustee  Guardian or Conservator

Other: \_\_\_\_\_

Signer Is Representing: \_\_\_\_\_

Signer's Name: \_\_\_\_\_

Corporate Officer — Title(s): \_\_\_\_\_

Partner —  Limited  General

Individual  Attorney in Fact

Trustee  Guardian or Conservator

Other: \_\_\_\_\_

Signer Is Representing: \_\_\_\_\_

**Iran Contracting Act**  
(Public Contract Code sections 2200-2208)

Prior to bidding on, submitting a proposal or executing a contract or renewal for a County of Riverside contract for goods or services of \$1,000,000 or more, a Contractor must either:

- a) Certify it is not on the current list of persons engaged in investment activities in Iran created by the California Department of General Services ("DGS") pursuant to Public Contract Code section 2203(b) and is not a financial institution extending twenty million dollars (\$20,000,000) or more in credit to another person, for 45 days or more, if that other person will use the credit to provide goods or services in the energy sector in Iran and is identified on the current list of persons engaged in investment activities in Iran created by DGS; or
- b) Demonstrate it has been exempted from the certification requirement for that solicitation or contract pursuant to Public Contract Code section 2203(c) or (d).

To comply with this requirement, please insert your Contractor or financial institution name and Federal ID Number (if available) and complete one of the options below. Please note: California law establishes penalties for providing false certifications, including civil penalties equal to the greater of \$250,000 or twice the amount of the contract for which the false certification was made; contract termination; and three-year ineligibility to bid on contracts. (Public Contract Code section 2205.)

**Option #1 – Certification**

I, the official named below, certify I am duly authorized to execute this certification on behalf of the vendor/financial institution identified below, and the vendor/financial institution identified below is **not** on the current list of persons engaged in investment activities in Iran created by DGS and is not a financial institution extending twenty million dollars (\$20,000,000) or more in credit to another person/vendor, for 45 days or more, if that other person/vendor will use the credit to provide goods or services in the energy sector in Iran and is identified on the current list of persons engaged in investment activities in Iran created by DGS.

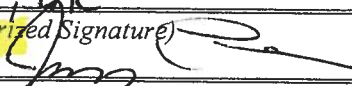
Contractor Name/Financial Institution (Printed) <b>DBX, Inc</b>		Federal ID Number (or n/a) <b>95-2458707</b>
By (Authorized Signature) 		
Printed Name and Title of Person Signing <b>Jim Perry, President</b>		
Date Executed <b>7/7/15</b>	Executed in <b>Temecula, CA</b>	

**Option #2 – Exemption**

Pursuant to Public Contract Code sections 2203(c) and (d), a public entity may permit a Contractor/financial institution engaged in investment activities in Iran, on a case-by-case basis, to be eligible for, or to bid on, submit a proposal for, or enters into or renews, a contract for goods and services.

If you have obtained an exemption from the certification requirement under the Iran Contracting Act, please fill out the information below, and attach documentation demonstrating the exemption approval.

Contractor Name/Financial Institution (Printed)		Federal ID Number (or n/a)
By (Authorized Signature)		
Printed Name and Title of Person Signing		
Date Executed	Executed in	





Juan C. Perez, P.E., T.E.  
Director of Transportation and Land  
Management

# COUNTY OF RIVERSIDE

## TRANSPORTATION AND LAND MANAGEMENT AGENCY



Patricia Romo, P.E.  
Assistant Director of Transportation

### Transportation Department

#### ADDENDUM NUMBER 1

Dated June 23, 2015

to the  
Specifications and Contract Documents  
for the construction of

Serfas Club Drive and Monterey Peninsula Drive  
Traffic Signal and Lighting Project  
In the Community of Coronita  
Project No. C5-0073

**Bids Due:** Wednesday, July 8, 2015; 2:00 p.m.  
14<sup>th</sup> Street Transportation Annex  
3525 14<sup>th</sup> Street; Riverside, CA 92501  
(951) 955-6780

This Addendum is issued pursuant to the Instructions to Bidders, Item No. 8, of the Contract Documents for the reference project. This Addendum is issued as a supplement to the specification and special provisions for the referenced project. The revisions to the specifications shall become a part of the Contract Documents, and each bidder shall acknowledge receipt thereof on the Bid (Proposal). Bidders are directed to sign this addendum as acknowledged, and attach the signed addendum to the contractor's submitted proposal.

Note: During the advertisement period of this project, this document and attachments (if any) are available upon request at the office of the Transportation Department, and are available as a free download at the Transportation Department's website:

<http://rctlma.org/trans/Contractors-Corner/Notices-Inviting-Bids>

#### MODIFICATIONS / CLARIFICATIONS TO SPECIAL PROVISIONS:

- Item 1: Revised Proposal.** Refer to "Proposal" page B2. Delete "Proposal" (page B2) and replace it with "Revised Proposal" attached herewith as **Attachment "A"**. The following changes have been made to the Proposal:
- The following bid item is deleted:  
Item 11, "MINOR CONCRETE [RETAINING CURB]"
  - The description and estimated quantity are revised for the following bid item:  
Item 14, "RETAINING WALL (MASONRY WALL) [PER CONSTRUCTION NOTE 9]"
  - The following bid items are added:  
Item 14.A, "RETAINING WALL (MASONRY WALL) [PER CONSTRUCTION NOTE 13]"  
Item 14.B, "HANDRAILING [PER APWA STD 606-3 TYPE B]"

**Item 2: Clarification of Retaining Wall.** Refer to Section 51, Concrete Structures, of the Special Provisions for the construction of RETAINING WALL (MASONRY WALL) [PER CONSTRUCTION NOTE 9].

**Item 3: Retaining Wall Special Provision.** The following Special Provisions are added and made part hereof:

**RETAINING WALL [PER CONSTRUCTION NOTE 13]**

Retaining wall shall be constructed per County of Riverside Building and Safety Department retaining wall standard and the detail shown on the plans, and shall conform to the applicable portions of Sections 51, 52, 55, 75 and 90 of the Standard Specifications and these Special Provisions, and as directed by the Engineer.

Removed materials of any kind in result of retaining walls construction shall be disposed of out of road Right of Way as specified elsewhere in these Special Provisions.

Payment

The contract bid price paid per linear foot for "Retaining Wall (Masonry Wall) [Per Construction Note 13]" shall include full compensation for furnishing all labor, tools, materials and equipment and doing all the work involved, including structure excavation and backfill, furnishing and placing reinforcement bars, and no additional compensation will be allowed therefor.

**Item 4: Hand Railing Special Provision.** The following Special Provisions are added and made part hereof:

**METAL HAND RAILING**

Metal hand railing shall conform to the APWA (Greenbook) Standard Plan 606-3, Type B, these Special Provisions, the details on the plans, the applicable portions of Sections 55 and 75 of the Standard Specifications, and as directed by the Engineer.

Metal railing shall consist of metal elements mounted on concrete members as shown on the plans.

Steel railing material shall be welded or seamless steel pipe.

Materials and construction for the railings shall conform to the following requirements:

Material	ASTM Designation
Tubular steel rails, and tubular hand railing	A 500, Grade B
Steel posts, rolled bars and plate washers	A 36/A 36M
Steel sleeves for tubular rails	A 36/A 36M
High strength bolts	A325 or A 325M or A 449
High strength threaded rods	A 449
Nuts and washers for high strength bolts and rods	A 325 or A 325M

The edges and center of the rail element shall contact each post or block. Rail element joints shall be lapped not less than 12-1/2 inches and bolted.

The ends of each length of railing shall be fitted with terminal sections.

Workmanship shall be equivalent to commercial practice and all edges, bolt holes, and surfaces shall be free of torn metal, burrs, sharp edges, and protrusions.

Bolts shall have shoulders of such shape that will prevent them from turning.

Unless otherwise specified, the rail elements, terminal sections, bolts, nuts, and other fittings shall be galvanized.

#### Installation

The railing shall be erected in accordance with the Plans on anchor bolts, or in holes formed by inserts provided in the concrete railing base to receive the railing posts. Sheet metal inserts shall be removed before the erection of the railing.

No railing shall be erected on the structure until the wall to which it is to be attached is completed and all falsework supporting the system is released.

The railing shall be carefully erected, true to line and grade. Posts and balusters shall be vertical with the deviation from the vertical for the full height of the panel not exceeding 1/8 inch.

After erecting the railing, any abrasions or exposed steel shall be repaired by Hot-Dip process or Metalizing Process as approved by the Resident Engineer.

#### Payment

The contract price paid per linear foot for Hand Railing shall include full compensation for furnishing all labor, materials, tools, equipment, and incidentals, and for doing all the work involved in constructing the railing, complete in place, including, but not limited to, any work and materials necessary to secure railing on top of retaining wall, excavation, backfill and disposal of surplus material, concrete and reinforcing steel, as shown on the plans, as specified in these special provisions and as directed by the Resident Engineer.

**Item 5: Retaining Wall and Hand Railing Reference Drawings.** County of Riverside Building and Safety Department Retaining Wall Standard, and APWA (Greenbook) Hand Railing Standard Plan 606-3 are provided and attached herewith as **Attachment "C"** for reference.

### **MODIFICATIONS / CLARIFICATIONS TO THE PLANS**

**Item 6: Plan sheet revisions.** The following Plan sheets are revised or added by **Attachment "B"** and made a part hereof:

a. Delete and replace the following two (2) plan sheets:

1. Plan sheet 2 of 5, L-1, Layout
2. Plan sheet 3 of 5, C-2, Construction Details

**Note:** All revised plan sheets are posted on the County website and are available for download during the advertisement period.

<http://rctlma.org/trans/Contractors-Corner/Notices-Inviting-Bids>

This addendum has been prepared under the direction of the following registered Civil Engineer(s):

  
\_\_\_\_\_  
Dowling Tsai, P.E.



**Concurrence:**

 6/22/15  
\_\_\_\_\_  
Khalid Nasim, P.E.  
Engineering Division Manager

**Acknowledged:**

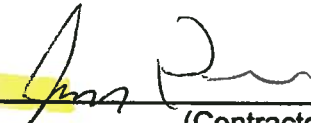
  
\_\_\_\_\_  
(Contractor)

Date: 7/7/15

JRJ:jjr:rr

Note: Refer to Section 8, "Addenda" (page A4). Submission of all addendum pages and non-bidding document attachments of addendum are not necessary for Bid submittal. Submittal of **only this** acknowledgement page is adequate for Bid reception. Bidders are reminded to list addendum number(s) received on the first page (B1) of the Bid form (Proposal).

## **ATTACHMENTS**

**A – Revised Proposal**

**B – Revised Plan Sheets (2)**

**C – Retaining Wall and Hand Railing Reference Drawings**

**Bid Bond**

**Recitals:**

1. DBX, INCORPORATED "Contractor", has submitted his/her Contractor's Proposal to County of Riverside, "County", for the construction of public work for Serfas Club Drive and Monterey Peninsula Drive, Traffic Signal and Lighting Project, In the Community of Coronita, Project No. C5-0073, in accordance with a Notice Inviting Bids from the County.
2. \*\* a MICHIGAN corporation, hereafter called "Surety", is the surety of this bond.  
\*\* THE GUARANTEE COMPANY OF NORTH AMERICA USA

**Agreement:**

We, Contractor as Principal and Surety as Surety, jointly and severally agree and state as follows:

1. The amount of the obligation of this bond is 10% of the amount of the Contractor's Proposal, including bid alternates, and inures to the benefit of County.
2. This Bond is exonerated by (1) County rejecting said Proposal or, in the alternate, (2) if said Proposal is accepted, Contractor executes the Contract and furnishes the Bonds as agreed to in its Proposal, otherwise it remains in full force and effect for the recovery of loss, damage and expense of County resulting from failure of Contractor to act as agreed to in its Proposal. Some types of possible loss, damage and expense are specified in the Contractor's Proposal.
3. Surety, for value received, stipulates and agrees that its obligations hereunder shall in no way be impaired or affected by any extension of time within which County may accept the Proposal and waives notice of any such extension.
4. This Bond is binding on our heirs, executors, administrators, successors and assigns.

Dated: 6/26/15

Signatures:

THE GUARANTEE COMPANY OF NORTH AMERICA USA      DBX, INCORPORATED

By: [Signature]      By: [Signature]

Title: Attorney in Fact      Title: President

SPENCER FLAKE "Surety"      "Contractor"

STATE OF \_\_\_\_\_ }  
 COUNTY \_\_\_\_\_ } ss. SURETY'S ACKNOWLEDGEMENT  
 OF \_\_\_\_\_ }

On \_\_\_\_\_ before me, \_\_\_\_\_  
 personally appeared, \_\_\_\_\_ known to me, or proved to me on the basis of  
 satisfactory evidence, to be the person whose name is subscribed to the within instrument and acknowledged  
 to me that he/she executed the same in his/her authorized capacities, and that by his/her signature on the  
 instrument the person, or the entity upon behalf of which the person acted, executed the instrument.

WITNESS my hand and official seal.

\_\_\_\_\_  
 Signature of Notary Public      Notary Public (Seal)

Note: This Bond must be executed by both Contractor and Surety with corporate seal affixed. All signatures must be notarized. (Attach acknowledgements).

COPY

**CALIFORNIA ALL-PURPOSE ACKNOWLEDGMENT**

**CIVIL CODE § 1189**

A notary public or other officer completing this certificate verifies only the identity of the individual who signed the document to which this certificate is attached, and not the truthfulness, accuracy, or validity of that document.

State of California )  
County of Riverside )

On 7/7/15 before me, Phyllissa Martz, Notary Public  
*Date Here Insert Name and Title of the Officer*

personally appeared Jim Perry  
*Name(s) of Signer(s)*

who proved to me on the basis of satisfactory evidence to be the person(s) whose name(s) is/are subscribed to the within instrument and acknowledged to me that he/she/they executed the same in his/her/their authorized capacity(ies), and that by his/her/their signature(s) on the instrument the person(s), or the entity upon behalf of which the person(s) acted, executed the instrument.

I certify under PENALTY OF PERJURY under the laws of the State of California that the foregoing paragraph is true and correct.

WITNESS my hand and official seal.

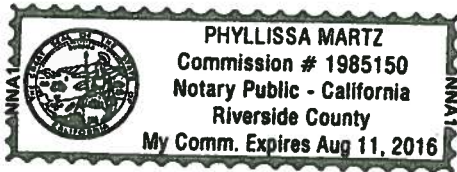

Signature Phyllissa Martz  
*Signature of Notary Public*

*Place Notary Seal Above*

**OPTIONAL**

*Though this section is optional, completing this information can deter alteration of the document or fraudulent reattachment of this form to an unintended document.*

**Description of Attached Document**

Title or Type of Document: \_\_\_\_\_ Document Date: \_\_\_\_\_

Number of Pages: \_\_\_\_\_ Signer(s) Other Than Named Above: \_\_\_\_\_

**Capacity(ies) Claimed by Signer(s)**

Signer's Name: Jim Perry

Corporate Officer -- Title(s): President

Partner --  Limited  General

Individual  Attorney in Fact

Trustee  Guardian or Conservator

Other: \_\_\_\_\_

Signer Is Representing: \_\_\_\_\_

Signer's Name: \_\_\_\_\_

Corporate Officer -- Title(s): \_\_\_\_\_

Partner --  Limited  General

Individual  Attorney in Fact

Trustee  Guardian or Conservator

Other: \_\_\_\_\_

Signer Is Representing: \_\_\_\_\_

COPY

**CALIFORNIA ALL-PURPOSE ACKNOWLEDGMENT**

**CIVIL CODE § 1189**

A notary public or other officer completing this certificate verifies only the identity of the individual who signed the document to which this certificate is attached, and not the truthfulness, accuracy, or validity of that document.

State of California )  
County of ORANGE )

On 6/26/15 before me, LEXIE SHERWOOD - NOTARY PUBLIC  
Date Here Insert Name and Title of the Officer

personally appeared SPENCER FLAKE  
Name(s) of Signer(s)

who proved to me on the basis of satisfactory evidence to be the person(s) whose name(s) is/are subscribed to the within instrument and acknowledged to me that he/she/they executed the same in his/her/their authorized capacity(ies), and that by his/her/their signature(s) on the instrument the person(s), or the entity upon behalf of which the person(s) acted, executed the instrument.

I certify under PENALTY OF PERJURY under the laws of the State of California that the foregoing paragraph is true and correct.

WITNESS my hand and official seal.



Signature Lexie Sherwood  
Signature of Notary Public

Place Notary Seal Above

**OPTIONAL**

Though this section is optional, completing this information can deter alteration of the document or fraudulent reattachment of this form to an unintended document.

**Description of Attached Document**

Title or Type of Document: \_\_\_\_\_ Document Date: \_\_\_\_\_  
Number of Pages: \_\_\_\_\_ Signer(s) Other Than Named Above: \_\_\_\_\_

**Capacity(ies) Claimed by Signer(s)**

Signer's Name: \_\_\_\_\_  
 Corporate Officer — Title(s): \_\_\_\_\_  
 Partner —  Limited  General  
 Individual  Attorney in Fact  
 Trustee  Guardian or Conservator  
 Other: \_\_\_\_\_  
Signer Is Representing: \_\_\_\_\_

Signer's Name: \_\_\_\_\_  
 Corporate Officer — Title(s): \_\_\_\_\_  
 Partner —  Limited  General  
 Individual  Attorney in Fact  
 Trustee  Guardian or Conservator  
 Other: \_\_\_\_\_  
Signer Is Representing: \_\_\_\_\_



COPY



The Guarantee Company of North America USA  
Southfield, Michigan

POWER OF ATTORNEY

KNOW ALL BY THESE PRESENTS: That THE GUARANTEE COMPANY OF NORTH AMERICA USA, a corporation organized and existing under the laws of the State of Michigan, having its principal office in Southfield, Michigan, does hereby constitute and appoint

David L. Culbertson, Charles L. Flake, Richard A. Coon, Spencer Flake  
Culbertson Insurance Services, Inc.

its true and lawful attorney(s)-in-fact to execute, seal and deliver for and on its behalf as surety, any and all bonds and undertakings, contracts of indemnity and other writings obligatory in the nature thereof, which are or may be allowed, required or permitted by law, statute, rule, regulation, contract or otherwise.

The execution of such instrument(s) in pursuance of these presents, shall be as binding upon THE GUARANTEE COMPANY OF NORTH AMERICA USA as fully and amply, to all intents and purposes, as if the same had been duly executed and acknowledged by its regularly elected officers at the principal office.

The Power of Attorney is executed and may be certified so, and may be revoked, pursuant to and by authority of Article IX, Section 9.03 of the By-Laws adopted by the Board of Directors of THE GUARANTEE COMPANY OF NORTH AMERICA USA at a meeting held on the 31<sup>st</sup> day of December, 2003. The President, or any Vice President, acting with any Secretary or Assistant Secretary, shall have power and authority:

1. To appoint Attorney(s)-in-fact, and to authorize them to execute on behalf of the Company, and attach the Seal of the Company thereto, bonds and undertakings, contracts of indemnity and other writings obligatory in the nature thereof; and
2. To revoke, at any time, any such Attorney-in-fact and revoke the authority given, except as provided below
3. In connection with obligations in favor of the Florida Department of Transportation only, it is agreed that the power and authority hereby given to the Attorney-in-Fact includes any and all consents for the release of retained percentages and/or final estimates on engineering and construction contracts required by the State of Florida Department of Transportation. It is fully understood that consenting to the State of Florida Department of Transportation making payment of the final estimate to the Contractor and/or its assignee, shall not relieve this surety company of any of its obligations under its bond.
4. In connection with obligations in favor of the Kentucky Department of Highways only, it is agreed that the power and authority hereby given to the Attorney-in-Fact cannot be modified or revoked unless prior written personal notice of such intent has been given to the Commissioner – Department of Highways of the Commonwealth of Kentucky at least thirty (30) days prior to the modification or revocation.

Further, this Power of Attorney is signed and sealed by facsimile pursuant to resolution of the Board of Directors of the Company adopted at a meeting duly called and held on the 6th day of December 2011, of which the following is a true excerpt:

RESOLVED that the signature of any authorized officer and the seal of the Company may be affixed by facsimile to any Power of Attorney or certification thereof authorizing the execution and delivery of any bond, undertaking, contracts of indemnity and other writings obligatory in the nature thereof, and such signature and seal when so used shall have the same force and effect as though manually affixed.



IN WITNESS WHEREOF, THE GUARANTEE COMPANY OF NORTH AMERICA USA has caused this instrument to be signed and its corporate seal to be affixed by its authorized officer, this 23rd day of February, 2012.

THE GUARANTEE COMPANY OF NORTH AMERICA USA

*Stephen C. Ruschak*

*Randall Musselman*

STATE OF MICHIGAN  
County of Oakland

Stephen C. Ruschak, President & COO

Randall Musselman, Secretary

On this 23rd day of February, 2012 before me came the individuals who executed the preceding instrument, to me personally known, and being by me duly sworn, said that each is the herein described and authorized officer of The Guarantee Company of North America USA; that the seal affixed to said instrument is the Corporate Seal of said Company; that the Corporate Seal and each signature were duly affixed by order of the Board of Directors of



Cynthia A. Takai  
Notary Public, State of Michigan  
County of Oakland  
My Commission Expires February 27, 2018  
Acting in Oakland County

IN WITNESS WHEREOF, I have hereunto set my hand at The Guarantee Company of North America USA offices the day and year above written.

*Cynthia A. Takai*

I, Randall Musselman, Secretary of THE GUARANTEE COMPANY OF NORTH AMERICA USA, do hereby certify that the above and foregoing is a true and correct copy of a Power of Attorney executed by THE GUARANTEE COMPANY OF NORTH AMERICA USA, which is still in full force and effect.



IN WITNESS WHEREOF, I have thereunto set my hand and attached the seal of said Company this 26th day of June, 2015.

*Randall Musselman*

Randall Musselman, Secretary



COPY

- Company Profile
- Company Search
- Company Information
- Old Company Names
- Agent for Service
- Reference Information
- NAIC Group List
- Lines of Business
- Workers' Compensation Complaint and Request for Action/Appeals Contact Information
- Financial Statements PDF's
- Annual Statements
- Quarterly Statements
- Company Complaint
- Company Performance & Comparison Data
- Company Enforcement Action
- Composite Complaints Studies
- Additional Info
- Find A Company Representative In Your Area
- View Financial Disclaimer

**COMPANY PROFILE**

**Company Information**

**GUARANTEE COMPANY OF NORTH AMERICA USA (THE)**  
**ONE TOWNE SQUARE, SUITE 1470**  
**SOUTHFIELD, MI 48076**

Old Company Names	Effective Date
MID-STATE SURETY CORPORATION	12/20/2006

**Agent For Service**  
 NANCY FLORES  
 C/O CT CORPORATION SYSTEM  
 818 WEST SEVENTH STREET, SUITE 930  
 LOS ANGELES CA 90017

**Reference Information**

NAIC #:	36650
California Company ID #:	4609-4
Date Authorized in California:	10/14/1999
License Status:	UNLIMITED-NORMAL
Company Type:	Property & Casualty
State of Domicile:	MICHIGAN

[back to top](#)

**NAIC Group List**

NAIC Group #: 0000

**Lines Of Business**

The company is authorized to transact business within these lines of insurance. For an explanation of any of these terms, please refer to the [glossary](#).

- AUTOMOBILE
- BOILER AND MACHINERY
- BURGLARY
- COMMON CARRIER LIABILITY
- CREDIT
- FIRE
- LEGAL INSURANCE
- LIABILITY
- MARINE
- MISCELLANEOUS
- PLATE GLASS
- SPRINKLER
- SURETY
- TEAM AND VEHICLE

[back to top](#)