

**SUBMITTAL TO THE BOARD OF SUPERVISORS
COUNTY OF RIVERSIDE, STATE OF CALIFORNIA**

507



FORM APPROVED COUNTY COUNSEL
 BY: GREGORY P. PRIAMOS DATE: 4/18/16
 Departmental Concurrence

FROM: Economic Development Agency

SUBMITTAL DATE:
April 21, 2016

SUBJECT: Chiriaco Summit Airport –Runway Pavement Rehabilitation Project, District 4, [\$582,551] Special Aviation Fund (22350) 31.5%, California Aid to Airports Program State Funds 68.5%

RECOMMENDED MOTION: That the Board of Supervisors:

1. Approve the Bid Documents for the Runway Pavement Rehabilitation Project;
2. Authorize the Clerk of the Board to Advertise for bids for Construction of Airport Improvements.
3. Upon completion of the bid process, authorize the Assistant County Executive Officer/EDA or designee to determine the award of the project and authorize the Chairman to execute the agreement with the lowest responsive and responsible bidder in accordance with Board Policy B-11; and

(Continued)

Robert Field

Robert Field
Assistant County Executive Officer/EDA

FISCAL PROCEDURES APPROVED
 PAUL ANGLIG CPA, AUDITOR-CONTROLLER
 BY: Esteban Hernandez DATE: 4/21/16

FINANCIAL DATA	Current Fiscal Year:	Next Fiscal Year:	Total Cost:	Ongoing Cost:	POLICY/CONSENT (per Exec. Office)
COST	\$ 0	\$ 582,551	\$ 582,551	\$	Consent <input type="checkbox"/> Policy <input checked="" type="checkbox"/>
NET COUNTY COST	\$	\$ 0	\$	\$	
SOURCE OF FUNDS: Special Aviation Fund (22350) 31.5%, California Aid to Airports Program State Funds 68.5%				Budget Adjustment: No	
				For Fiscal Year: 2015/16	

C.E.O. RECOMMENDATION:

REVIEWED BY CIP

APPROVE

Ivan M. Chand

BY: *Rohini Dasika*

Ivan M. Chand

Rohini Dasika

County Executive Office Signature

4/20/2016

MINUTES OF THE BOARD OF SUPERVISORS

- A-30
- 4/5 Vote
- Positions Added
- Change Order

Prev. Agn. Ref.: 3.6 of 10/27/15

District: 4

Agenda Number:

3-12

SUBMITTAL TO THE BOARD OF SUPERVISORS, COUNTY OF RIVERSIDE, STATE OF CALIFORNIA

Economic Development Agency

FORM 11: Chiriaco Summit Airport –Runway Pavement Rehabilitation Project, District 4, [\$582,551] Special Aviation Fund (22350) 31.5%, California Aid to Airports Program State Funds 68.5%

DATE: April 21, 2016

PAGE: 2 of 2

RECOMMENDED MOTION: (Continued)

4. Delegate Change Order authority to the Assistant County Executive Officer/EDA or designee in accordance with Board Policy B-11

BACKGROUND:

Summary

On June 25, 2015 the California Transportation Commission (Commission), acting on the California Department of Transportation's (Caltrans) recommendation, allocated California Aid to Airports Program (CAAP) funds to the County of Riverside, for the Runway Pavement Rehabilitation Project at Chiriaco Summit Airport.

This project involves a 2" overlay (50' x 4,000') of the asphalt concrete runway at the Chiriaco Summit Airport. The pavement was constructed prior to 1950, and displays severe cracking, raveling, rutting and distortion. Alligator cracking and potholes are evident in approximately 30% of the runway pavement. Specific improvements will include surface preparation, crack repairs, pavement overlay, pavement marking removal, and application of pavement marking.

The California Department of Transportation (CALTRANS), Division of Aeronautics, will review and approve the contract documents. This project will be funded with the Special Aviation Fund, and the California Department of Transportation (CALTRANS), Division of Aeronautics allocation of California Aid to Airports Program (CAAP) funds.

Impact on Citizens and Businesses

The rehabilitation of the Runway Pavement will improve the airport operations and enhance capacity and safety.

SUPPLEMENTAL:

Additional Fiscal Information

The California Aid to Airports Program (CAAP) will fund 68.5%, and 31.5% will be taken from the Restricted Fund Balance held for airport improvements in Special Aviation Fund 22350. The engineer's construction cost estimate for this project is \$582,551. There will be no impact on the County's general fund.

ATTACHMENTS:

Caltrans Authorization Letter

Contract Documents and Specifications

DEPARTMENT OF TRANSPORTATION

DIVISION OF AERONAUTICS
1120 N STREET, SUITE 3300
P.O. BOX 942874, MS-40
SACRAMENTO, CA 94274-0001
PHONE (916) 654-4959
FAX (916) 653-9531
TTY 711
www.dot.ca.gov



*Serious drought.
Help save water!*

March 29, 2016

Mr. Daryl Shippy, Airport Manager
Chiriaco Summit Airport
County of Riverside
3403 10th St., Suite 500
Riverside, CA 92501-3658

Dear Mr. Shippy:

The California Department of Transportation (Caltrans), Division of Aeronautics, has reviewed the plans and specifications for Project CAAP # Riv-4-14-1 for Runway Paving and Grading at the Chiriaco Summit Airport. Please ensure comments are included for plans and specifications as below.

Specifications

1. Add phone number, 877-487-6867 for NOTAMT.
2. On Construction Safety set, first page, please remove the line with "Caltrans Project Manager."

Plans

1. On cover sheet G-001, add NOTAM with phone number, 877-487-6867.

One copy of the approved plans and specifications is being returned for your records. This letter is a confirmation of the authorization given to the County of Riverside (County) to solicit construction bids for both projects and to confirm Caltrans' maximum allocation of \$479,000 to the County for these projects.

When bids are received, please submit an abstract of the bids, together with the County's designation of the successful bidder for Caltrans' approval. After approval, Caltrans will initiate a Grant Agreement setting forth the terms under which State funds will be disbursed, and will authorize the award of the State's portion of the construction project. If, for any reason, the State does not approve the designated bidder, or if the designated bidder refuses to enter into the contract, the County may recommend that the award be given to the next lowest bidder, or that the project be rebid.

Mr. Daryl Shippy, Airport Manager

March 29, 2016

Page 2

The above approval of specifications should not be construed as assurance that State funds will be available for items not related to the Runway Paving and Grading Project.

If you have any questions, please contact me at (916) 657-0543 or by email at parvin.bijani@dot.ca.gov.

Sincerely,

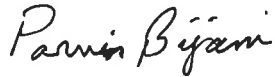

PARVIN BIJANI, P.E.
Airport Engineer
Office of Program and Technical Services

Enclosures

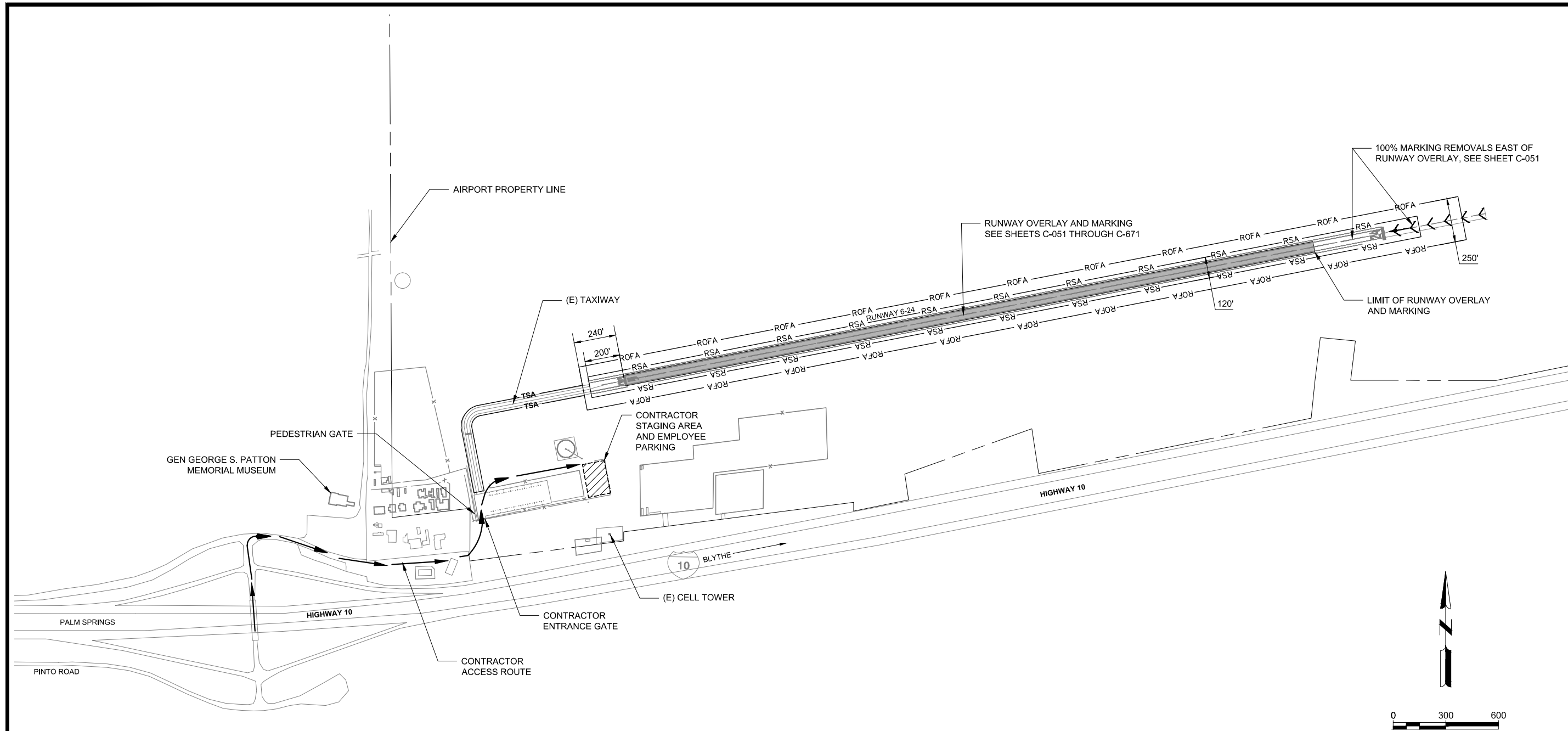

GENERAL CONSTRUCTION NOTES:

1. CONTRACTOR'S ACCESS TO THE AIRPORT SHALL BE AS APPROVED BY THE COUNTY. THE CONTRACTOR SHALL BE RESPONSIBLE FOR REPAIRING ANY DAMAGE TO PAVEMENTS OR OTHER EXISTING FACILITIES CAUSED BY CONSTRUCTION ACTIVITIES INCLUDING UNDERGROUND UTILITIES. THE STAGING AND STORAGE OF CONSTRUCTION MATERIALS AND EQUIPMENT SHALL BE AS SHOWN OR OTHERWISE APPROVED BY THE COUNTY. CONSTRUCTION TRAFFIC IS LIMITED TO APPROVED HAUL AND ACCESS ROUTES. HAUL ROUTES ON PAVEMENTS SHALL BE CLEANED EACH DAY. HAUL ROUTES OVER DIRT/GRAVEL SHALL BE SMOOTH GRADED AND OBLITERATED UPON COMPLETION OF THE PROJECT. DUST CONTROL SHALL BE MAINTAINED BY THE CONTRACTOR AT THE DISCRETION OF THE COUNTY.
2. THE FOLLOWING DOCUMENTS ARE CONSIDERED A PART OF THESE PLANS BY REFERENCE:
 - 2010 CALTRANS STANDARD SPECIFICATIONS.
 - FAA AC 150/5340-1L STANDARDS FOR AIRPORT MARKINGS
 - FAA AC 150/5370-2E OPERATIONAL SAFETY ON AIRPORTS DURING CONSTRUCTION
 - FAA AC 150/5370-10G STANDARDS FOR SPECIFYING CONSTRUCTION OF AIRPORTS
3. NO WORK SHALL BEGIN UNTIL THE CONTRACTOR HAS RECEIVED A NOTICE TO PROCEED FROM THE CALTRANS, DIVISION OF AERONAUTICS.



These documents shall not be used for any purpose or project for which it is not intended. Mead & Hunt shall be indemnified by the client and held harmless from all claims, damages, liabilities, losses, and expenses, including attorneys' fees and costs, arising out of such misuse or reuse of the documents. In addition, unauthorized reproduction of these documents, in part or as a whole, is prohibited.

COUNTY OF RIVERSIDE
L77 CHIRIACO SUMMIT AIRPORT
RUNWAY PAVING AND GRADING

62450 CHIRIACO ROAD, CHIRIACO SUMMIT, CA 92201

ISSUED

BID SET

CAAP NO: RIV-4-14-1
M&H NO: 3169800-155792.01
DATE: FEBRUARY 2016
DESIGNED BY: MSA
DRAWN BY: JML
CHECKED BY: RAC
DO NOT SCALE DRAWINGS

SHEET CONTENTS

PROJECT LAYOUT
PLAN

SHEET NO. 3 of 10

G-021

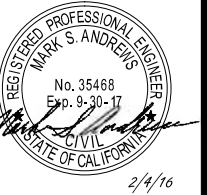

These documents shall not be used for any purpose or project for which it is not intended. Mead & Hunt shall be indemnified by the client and held harmless from all claims, damages, liabilities, losses and expenses, including attorneys' fees and costs, arising out of such misuse or reuse of the documents. In addition, unauthorized reproduction of these documents, in part or as a whole, is prohibited.

COUNTY OF RIVERSIDE
L77 CHIRIACO SUMMIT AIRPORT
RUNWAY PAVING AND GRADING
62450 CHIRIACO ROAD, CHIRIACO SUMMIT, CA 92201

BID SET

CAAP NO: RIV-4-14-1
M&H NO: 3169800-155792.01
DATE: FEBRUARY 2016
DESIGNED BY: JML
DRAWN BY: JML
CHECKED BY: RAC
DO NOT SCALE DRAWINGS

SHEET CONTENTS
CONSTRUCTIONS
SAFETY PHASING
PLAN

SHEET NO. 4 of 10

G-081

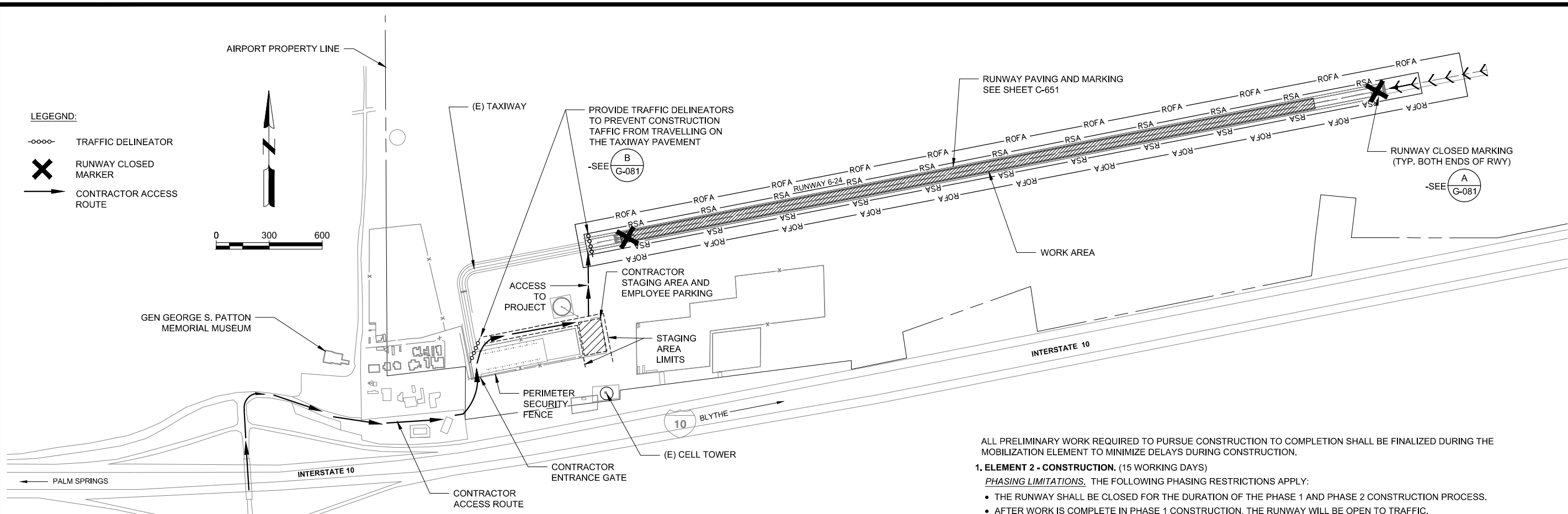

- LEGEND:**
- o---o---o--- TRAFFIC DELINEATOR
 - X RUNWAY CLOSED MARKER
 - CONTRACTOR ACCESS ROUTE

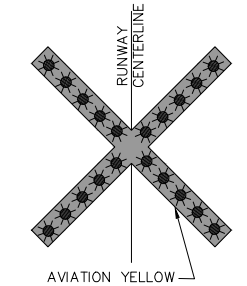

NOTE:
TEMPORARY CLOSED RUNWAY MARKERS SHALL BE PROVIDED BY COUNTY, MOVED AND MAINTAINED BY THE CONTRACTOR DURING CONSTRUCTION PER THE SCHEDULE APPROVED BY THE ENGINEER. CLOSED RUNWAY MARKERS ARE LIGHTED TRAILER MOUNTED, AND EQUIPPED WITH A PORTABLE DIESEL GENERATOR. CLOSED RUNWAY MARKERS SHALL BE RETURNED TO THE AIRPORT IN GOOD CONDITION, FULL OF FUEL AND FRESH FILTERS AT THE END OF THE PROJECT.

A CLOSED RUNWAY MARKERS
NO SCALE

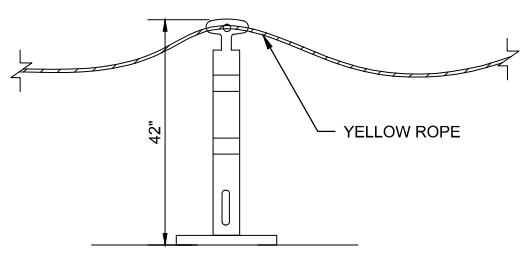

B TRAFFIC DELINEATOR
NO SCALE

- GENERAL PHASING NOTES:**
- CONTRACTOR SHALL REMAIN WITHIN THE LIMITS OF THE CONTRACTOR STAGING AREA AS WELL AS THE WORK AREAS DESIGNATED ON THE PLANS. CONSTRUCTION TRAFFIC SHALL BE RESTRICTED FROM TRAVELING ON OR ACROSS THE EXISTING TAXIWAY PAVEMENT EXCEPT AS APPROVED BY THE COUNTY.
 - THE CONTRACTOR SHALL NOTIFY THE COUNTY PRIOR TO STARTING ANY WORK ON THE AIRPORT. A MINIMUM OF 48 HOURS ADVANCE NOTICE IS REQUIRED. PHONE: (951) 955-9418.
 - THE CONTRACTOR IS RESPONSIBLE FOR SUPPLYING AND PLACING TRAFFIC DELINEATORS AND YELLOW ROPE AS REQUIRED.
 - COUNTY SHALL ISSUE A RUNWAY CLOSURE NOTAM PRIOR TO CONTRACTOR STARTING WORK.
 - RUNWAY CLOSURE MARKERS SHALL BE IN-PLACE, OPERATING, AND APPROVED BY COUNTY PRIOR TO CONTRACTOR STARTING WORK.

PHASING AND TIME LIMITATIONS
THE PROJECT HAS BEEN DIVIDED INTO TWO ELEMENTS: 1) MOBILIZATION AND 2) CONSTRUCTION. THE CONSTRUCTION ELEMENT HAS BEEN DIVIDED INTO PHASES TO SEPARATE THE CONSTRUCTION AREAS AND DEFINE THE SEQUENCE OF THE WORK ASSOCIATED WITH THE PROJECT. A SEPARATE NOTICE TO PROCEED SHALL BE ISSUED FOR MOBILIZATION ELEMENT AND THE CONSTRUCTION ELEMENT. THE NOTICE TO PROCEED FOR THE CONSTRUCTION ELEMENT WILL NOT BE ISSUED UNTIL THE MOBILIZATION ELEMENT IS COMPLETE AND THE SPCD IS APPROVED. THE WORK EFFORTS AND AFFECTED AIRFIELD AREAS WITHIN THE AOA ARE DETAILED BELOW. THE MOBILIZATION ELEMENT SHALL BE COMPLETED WITHIN TWENTY (20) WORKING DAYS AND THE CONSTRUCTION ELEMENT (PHASES 1-CONSTRUCTION, PHASE 2 - FINAL PAVEMENT MARKINGS) SHALL BE COMPLETED WITHIN FIFTEEN (15) WORKING DAYS. IF THE CONTRACTOR FAILS TO MEET ANY OF THESE TIME LIMITATIONS, LIQUIDATED DAMAGES WILL BE ASSESSED AS DESCRIBED IN SECTION ___ OF THE PROJECT SPECIFICATIONS.

- 1. ELEMENT 1 - MOBILIZATION. (20 WORKING DAYS)**
DURING THIS ELEMENT OF THE PROJECT, NO WORK SHALL BE CONDUCTED THAT IN ANY WAY RESTRICTS AIRPORT OPERATIONS. MOBILIZATION WORK SHALL INCLUDE, BUT NOT BE LIMITED TO, THE FOLLOWING:
- PROCESSING OF REQUIRED SUBMITTALS, INCLUDING THE CONTRACTOR'S WORK SCHEDULE.
 - PREPARATION AND SUBMISSION OF THE SPCD.
 - ALL PREQUALIFICATION TESTING, REVIEW, AND APPROVAL.
 - MIX DESIGN PREPARATION, REVIEW, AND APPROVAL.
 - AIRFIELD SAFETY DEVICES DELIVERED TO SITE (CONSTRUCTION FLAGS, LOW PROFILE BARRICADES, AIRPORT RADIOS, RUNWAY CLOSURE MARKERS).
 - ALL MISCELLANEOUS MOBILIZATION EFFORTS REQUIRED TO COMMENCE CONSTRUCTION.
 - MATERIALS AND EQUIPMENT DELIVERED TO SITE, AS APPLICABLE.
 - CONTRACTOR STAGING AREA SETUP AND UTILITY CONNECTIONS.

ALL PRELIMINARY WORK REQUIRED TO PURSUE CONSTRUCTION TO COMPLETION SHALL BE FINALIZED DURING THE MOBILIZATION ELEMENT TO MINIMIZE DELAYS DURING CONSTRUCTION.

- 1. ELEMENT 2 - CONSTRUCTION. (15 WORKING DAYS)**
PHASING LIMITATIONS. THE FOLLOWING PHASING RESTRICTIONS APPLY:
- THE RUNWAY SHALL BE CLOSED FOR THE DURATION OF THE PHASE 1 AND PHASE 2 CONSTRUCTION PROCESS.
 - AFTER WORK IS COMPLETE IN PHASE 1 CONSTRUCTION, THE RUNWAY WILL BE OPEN TO TRAFFIC.
 - AFTER THE NEW PAVEMENT WORK HAS CURED FOR 30 CALENDAR DAYS, A SEPARATE NOTICE TO PROCEED WITH PHASE 2 - FINAL PAVEMENT MARKINGS WILL BE ISSUED BY THE COUNTY.
 - PRIOR TO REOPENING AIRFIELD PAVEMENTS TO TRAFFIC, THE AREAS MUST BE SAFETY AREA COMPLIANT PER SECTION IV.Q "PROTECTION OF RUNWAY AND TAXIWAY CRITICAL AREAS" FOR ALL PHASES.
- a) PHASE 1 - AIRPORT RUNWAY CLOSURE PERIODS (14 WORKING DAYS).** PHASE 1 SHALL INCLUDE THE PAVEMENT MARKING REMOVAL, SURFACE PREPARATION FOR CRACK SEALS AND 2-INCH OVERLAY, THE PLACEMENT OF THE 2-INCH OVERLAY, AND THE FIRST APPLICATION OF RUNWAY PAVEMENT MARKINGS.
- PHASE 1 SUMMARY**
- SCOPE OF WORK - WORK WITHIN THE RUNWAY SAFETY AREAS.
 - AREA CLOSED TO AIRCRAFT OPERATIONS - AIRPORT RUNWAY AND TAXIWAY.
 - DURATION OF CLOSURE - FOURTEEN (14) WORKING DAYS.
 - ALTERNATE TAXI ROUTE - NOT APPLICABLE.
 - EMERGENCY ACCESS ROUTES - NOT REQUIRED DUE TO RUNWAY CLOSURE.
 - CONSTRUCTION STAGING AREA - MATERIAL AND EQUIPMENT STORAGE AS SHOWN PER PLAN SHEET G-021 AND G-081.
 - CONSTRUCTION ACCESS AND HAUL ROUTE - PER PLAN SHEET DETAIL SHOWN ON PAGE G-021 AND G-081.
 - IMPACTS TO NAVAIDS - NONE, THERE ARE NO NAVAIDS.
 - LIGHTING AND MARKING CHANGES - NONE, THERE ARE NO LIGHTS.
 - REQUIRED HAZARD MARKING AND LIGHTING - LIGHTED RUNWAY CLOSURE MARKER AND FLASHING AMBER LIGHTS AND/OR FLAGS ON EQUIPMENT AND VEHICLES.
 - LEAD TIMES FOR REQUIRED NOTIFICATION - TWO (2) WORKING DAYS.
- ADDITIONAL PHASE 1 NOTES:**
- SEE PHASING LIMITATIONS ABOVE.
- b) PHASE 2 - AIRPORT RUNWAY CLOSURE PERIODS (1 WORKING DAY).** PHASE 2 SHALL CONSIST OF THE FINAL APPLICATION OF PAVEMENT MARKINGS.
- PHASE 2 SUMMARY**
- SCOPE OF WORK - WORK WITHIN THE RUNWAY SAFETY AREAS.
 - AREA CLOSED TO AIRCRAFT OPERATIONS - AIRPORT RUNWAY AND TAXIWAY.
 - DURATION OF CLOSURE - ONE (1) WORKING DAY.
 - ALTERNATE TAXI ROUTE - NOT APPLICABLE.
 - EMERGENCY ACCESS ROUTES - NOT REQUIRED DUE TO RUNWAY CLOSURE.
 - CONSTRUCTION STAGING AREA - MATERIAL AND EQUIPMENT STORAGE AS SHOWN PER PLAN SHEET G-021 AND G-081.
 - CONSTRUCTION ACCESS AND HAUL ROUTE - PER PLAN SHEET DETAIL SHOWN ON PAGE G-021 AND G-081.
 - IMPACTS TO NAVAIDS - NONE, THERE ARE NO NAVAIDS.
 - LIGHTING AND MARKING CHANGES - NONE, THERE ARE NO LIGHTS.
 - REQUIRED HAZARD MARKING AND LIGHTING - LIGHTED RUNWAY CLOSURE MARKER AND FLASHING AMBER LIGHTS AND/OR FLAGS ON EQUIPMENT AND VEHICLES.
 - LEAD TIMES FOR REQUIRED NOTIFICATION - FIVE (5) WORKING DAYS.
- ADDITIONAL PHASE 2 NOTES:**
- SEE PHASING LIMITATIONS ABOVE.
- 2. CONSTRUCTION SAFETY AND PHASING PLAN SHEETS.** DRAWINGS SPECIFICALLY INDICATING OPERATIONAL SAFETY PROCEDURES AND METHODS IN AFFECTED AREAS HAVE BEEN DEVELOPED FOR EACH CONSTRUCTION PHASE AND WORK AREA. THESE DRAWINGS ARE INCLUDED IN THE CONTRACT DRAWING BID PACKAGE (PLAN SHEETS G-021 AND G-081).

X:\13186800\155792\17\TECH\DRAWINGS\C081 - CONSTRUCTION OPERATION AND SAFETY PLAN.DWG 02/28/2016 2:52 PM

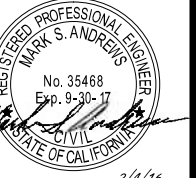

These documents shall not be used for any purpose or project for which it is not intended. Mead & Hunt shall be indemnified by the client and held harmless from all claims, damages, liabilities, losses, and expenses, including attorneys' fees and costs, arising out of such misuse or reuse of the documents. In addition, unauthorized reproduction of these documents, in part or as a whole, is prohibited.

COUNTY OF RIVERSIDE
L77 CHIRIACO SUMMIT AIRPORT
RUNWAY PAVING AND GRADING

62450 CHIRIACO ROAD, CHIRIACO SUMMIT, CA 92201

ISSUED

BID SET

CAAP NO: RIV-4-14-1
MAH NO: 3169800-155792.01
DATE: FEBRUARY 2016
DESIGNED BY: JML
DRAWN BY: JML
CHECKED BY: MSA
DO NOT SCALE DRAWINGS

SHEET CONTENTS
DEMOLITION PLAN

SHEET NO. 5 of 10

C-051

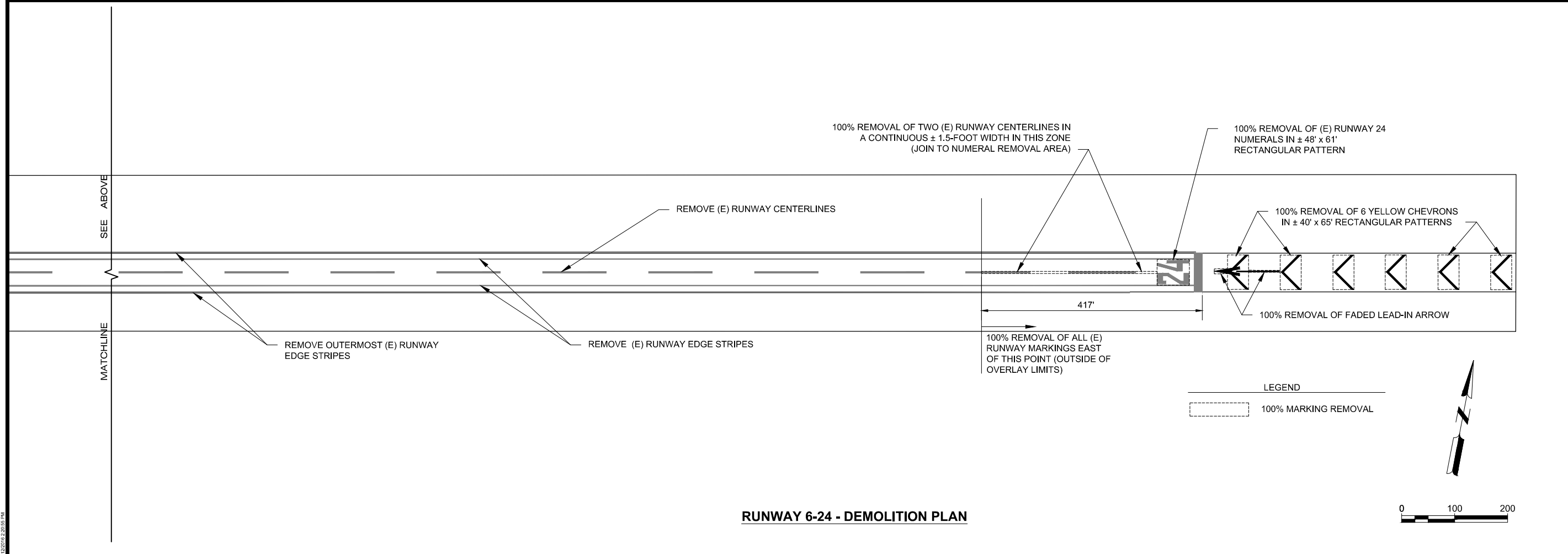
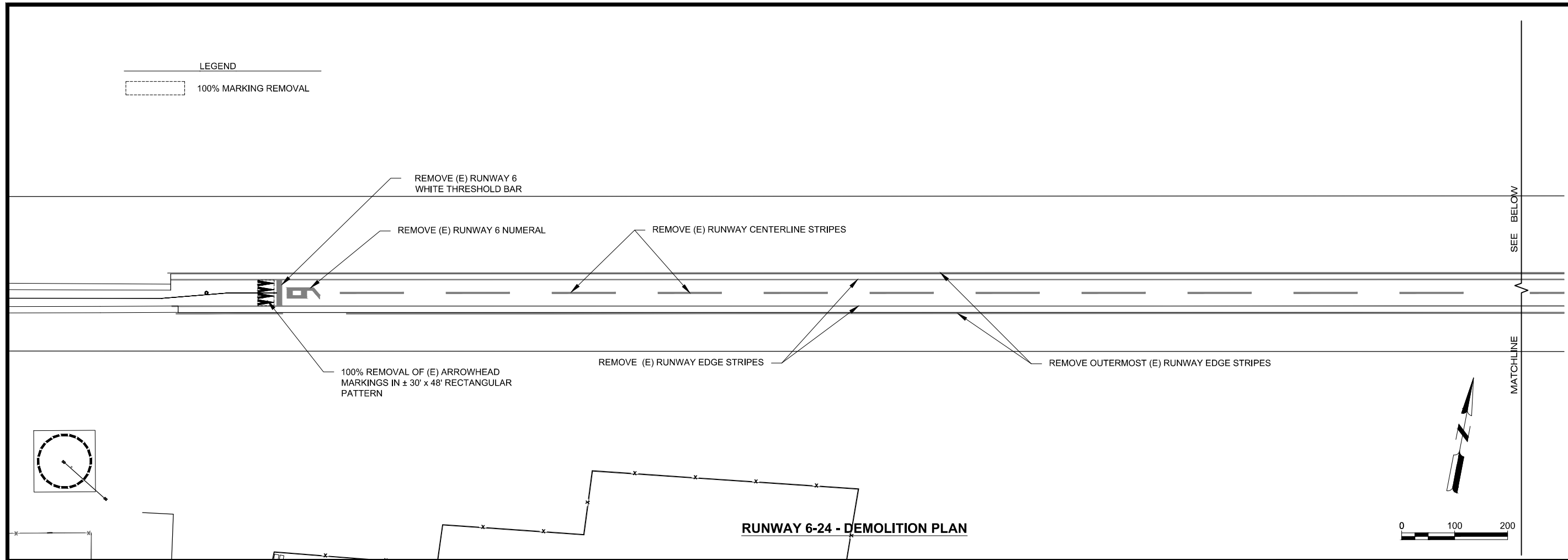

X:\3169800\7878\01\TECH\DRAWINGS\C-051 DEMOLITION PLAN AND DETAILS.DWG
2/2/2016 2:55:24 PM



2/4/16

These documents shall not be used for any purpose or project for which it is not intended. Mead & Hunt shall be indemnified by the client and held harmless from all claims, damages, liabilities, losses, and expenses, including attorneys' fees and costs, arising out of such misuse or reuse of the documents. In addition, unauthorized reproduction of these documents, in part or as a whole, is prohibited.

COUNTY OF RIVERSIDE
L77 CHIRIACO SUMMIT AIRPORT
RUNWAY PAVING AND GRADING

62450 CHIRIACO ROAD, CHIRIACO SUMMIT, CA 92201

BID SET

CAAP NO: RIV-4-14-1
MAH NO: 3169800-155792.01
DATE: FEBRUARY 2016
DESIGNED BY: JML
DRAWN BY: JML
CHECKED BY: MSA
DO NOT SCALE DRAWINGS

SHEET CONTENTS
PAVING PLAN

SHEET NO. 6 of 10

C-101

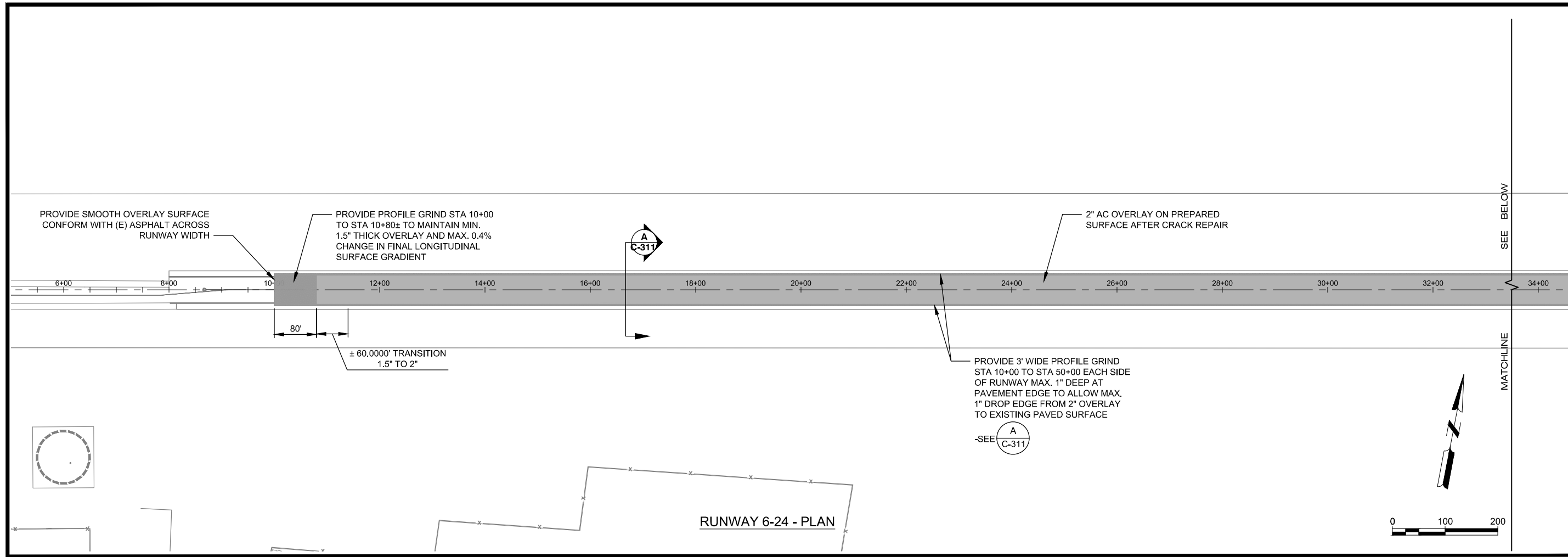

RUNWAY 6-24 - PLAN

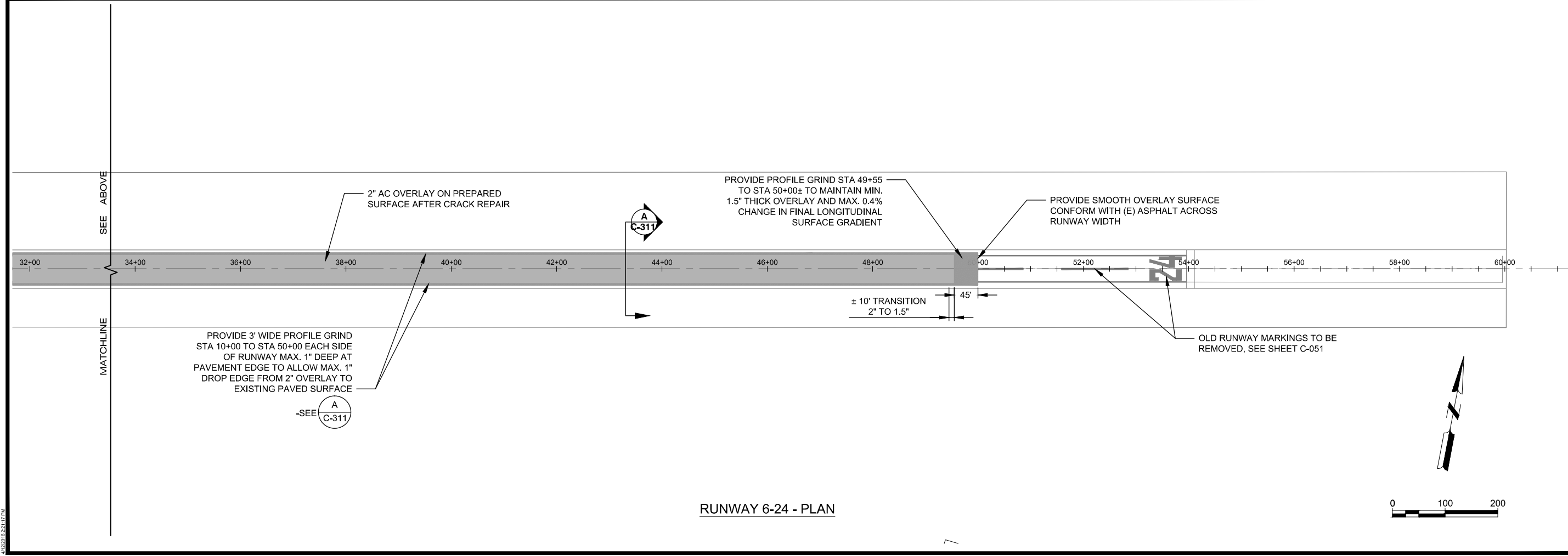

RUNWAY 6-24 - PLAN

X:\3169800\155792\01\TECH\DRAWINGS\C-101 PAVING PLAN.DWG
2/22/2016 2:21:17 PM

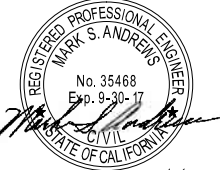

2/4/16

These documents shall not be used for any purpose or project for which it is not intended. Mead & Hunt shall be indemnified by the client and hold harmless from all claims, damages, liabilities, losses, and expenses, including attorneys' fees and costs, arising out of such misuse or reuse of the documents. In addition, unauthorized reproduction of these documents, in part or as a whole, is prohibited.

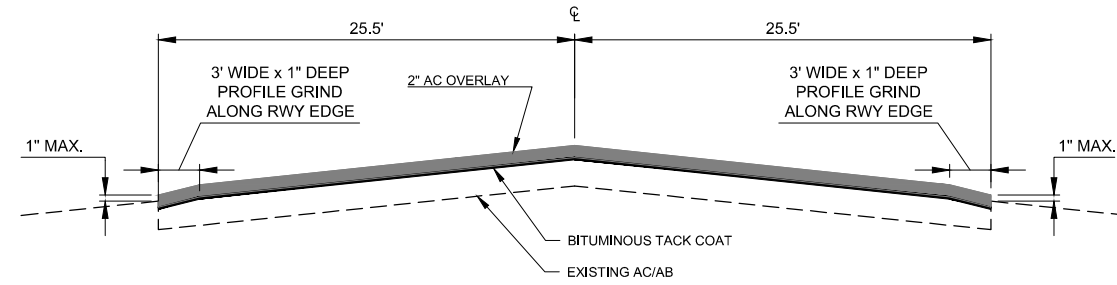

A RUNWAY OVERLAY SECTION
NO SCALE

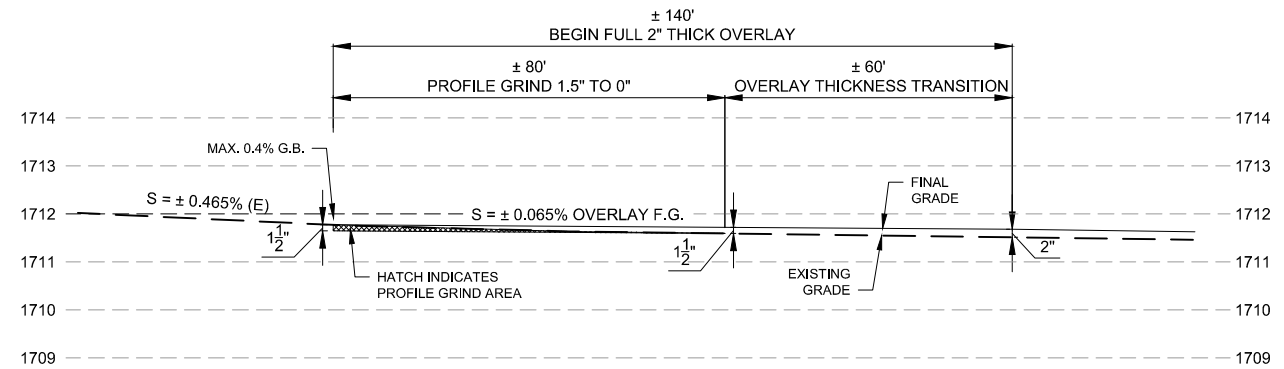

B RUNWAY 6 END PROFILE GRIND STA 10+00 TO 10+80
NO SCALE

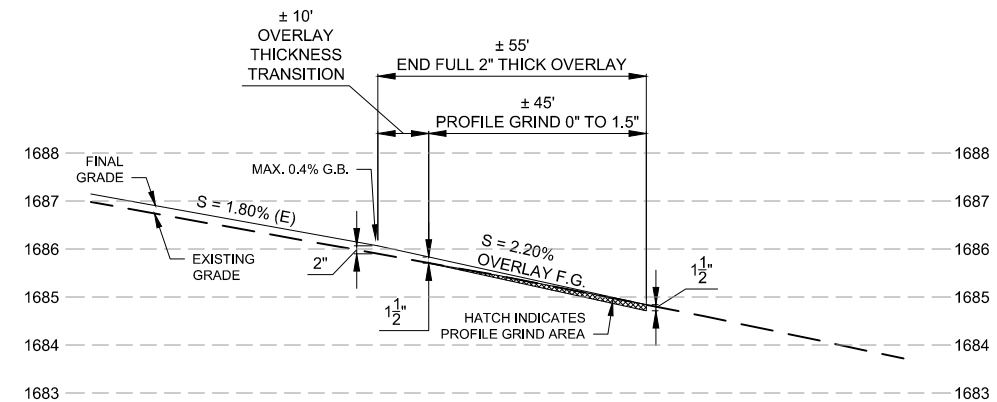

C RUNWAY 24 END PROFILE GRIND STA 49+55 TO 50+00
NO SCALE

NOTES

1. ELEVATIONS AND EXISTING GRADES ARE APPROXIMATE, DERIVED FROM AVAILABLE TOPOGRAPHIC INFORMATION.
2. CONTRACTOR SHALL SURVEY PROFILE GRIND AREAS AND PROVIDE GRADE CONTROL SHOTS.
3. RUNWAY END OVERLAY CONFORMS SHALL BE SMOOTH AND RUNWAY FINAL PROFILE SHALL HAVE LESS THAN 0.4% GRADE BREAKS.
4. PROFILE GRIND ALONG BOTH RUNWAY EDGES SHALL BE A MINIMUM 3" WIDE AND 1" DEEP TO PROVIDE MAXIMUM 1" DROP EDGE.

COUNTY OF RIVERSIDE
L77 CHIRIACO SUMMIT AIRPORT
RUNWAY PAVING AND GRADING
62450 CHIRIACO ROAD, CHIRIACO SUMMIT, CA 92201

ISSUED
BID SET

CAAP NO: RIV-4-14-1
M&H NO: 3169800-155792.01
DATE: FEBRUARY 2016
DESIGNED BY: JML
DRAWN BY: JML
CHECKED BY: MSA
DO NOT SCALE DRAWINGS

SHEET CONTENTS
PAVING DETAILS

SHEET NO. 7 of 10

C-311

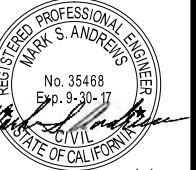

2/4/16
These documents shall not be used for any purpose or project for which it is not intended. Mead & Hunt shall be indemnified by the client and hold harmless from all claims, damages, liabilities, losses, and expenses, including attorneys' fees and costs, arising out of such misuse or reuse of the documents. In addition, unauthorized reproduction of these documents, in part or as a whole, is prohibited.

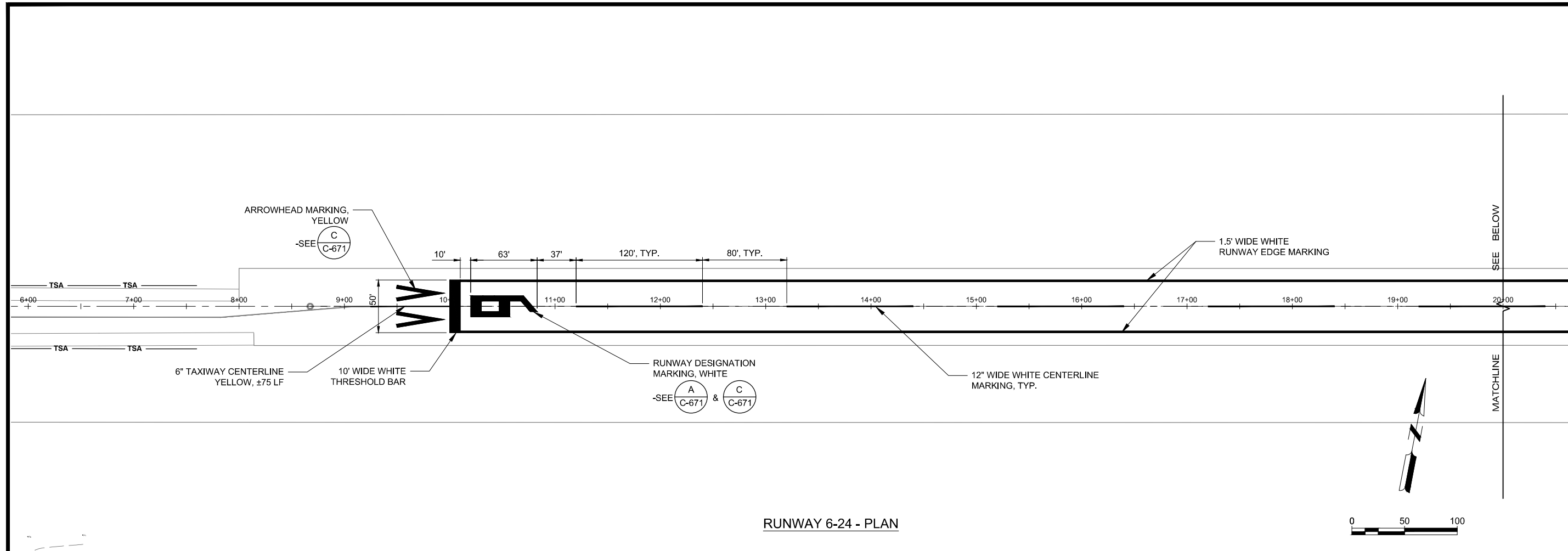

RUNWAY 6-24 - PLAN

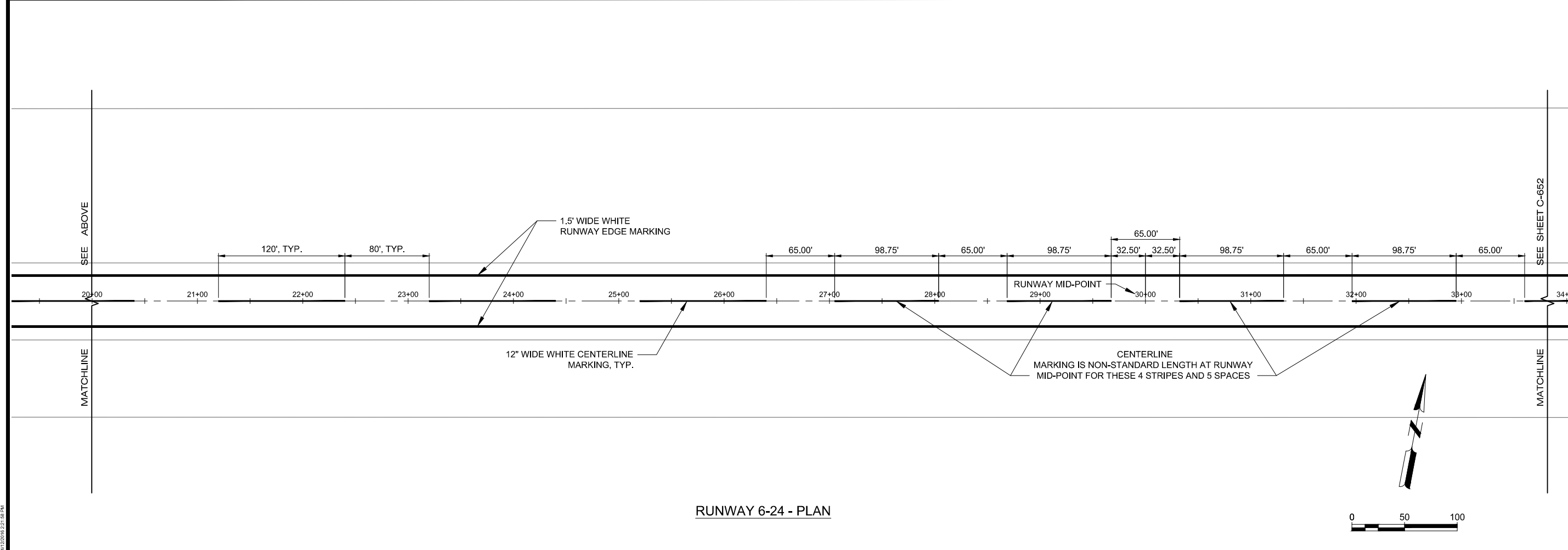

RUNWAY 6-24 - PLAN

COUNTY OF RIVERSIDE
L77 CHIRIACO SUMMIT AIRPORT
RUNWAY PAVING AND GRADING
62450 CHIRIACO ROAD, CHIRIACO SUMMIT, CA 92201

ISSUED
BID SET

CAAP NO: RIV-4-14-1
MAH NO.: 3169800-155792.01
DATE: FEBRUARY 2016
DESIGNED BY: JML
DRAWN BY: JML
CHECKED BY: MSA
DO NOT SCALE DRAWINGS

SHEET CONTENTS
MARKING PLAN-1

SHEET NO. 8 of 10

C-651

X:\3169800\155792\7\TECH\DRAWINGS\C-651 MARKING PLAN.DWG
2/2/2016 2:41:38 PM

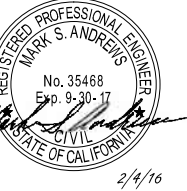

These documents shall not be used for any purpose or project for which it is not intended. Mead & Hunt shall be indemnified by the client and held harmless from all claims, damages, liabilities, losses and expenses, including attorneys' fees and costs, arising out of such misuse or reuse of the documents. In addition, unauthorized reproduction of these documents, in part or as a whole, is prohibited.

COUNTY OF RIVERSIDE
L77 CHIRIACO SUMMIT AIRPORT
RUNWAY PAVING AND GRADING

62450 CHIRIACO ROAD, CHIRIACO SUMMIT, CA 92201

ISSUED

BID SET

CRAP NO: RIV-4-14-1
M&H NO: 3169800-155792.01
DATE: FEBRUARY 2016
DESIGNED BY: JML
DRAWN BY: JML
CHECKED BY: MSA
DO NOT SCALE DRAWINGS

SHEET CONTENTS
MARKING PLAN-2

SHEET NO. 9 of 10

C-652

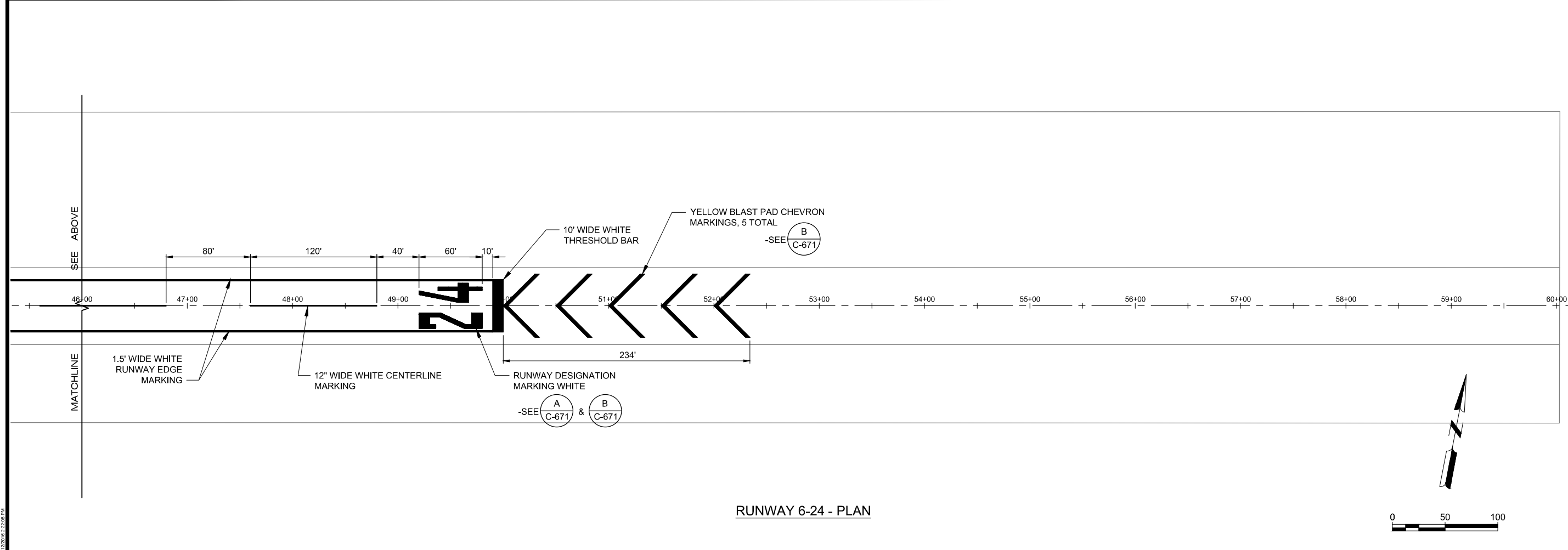
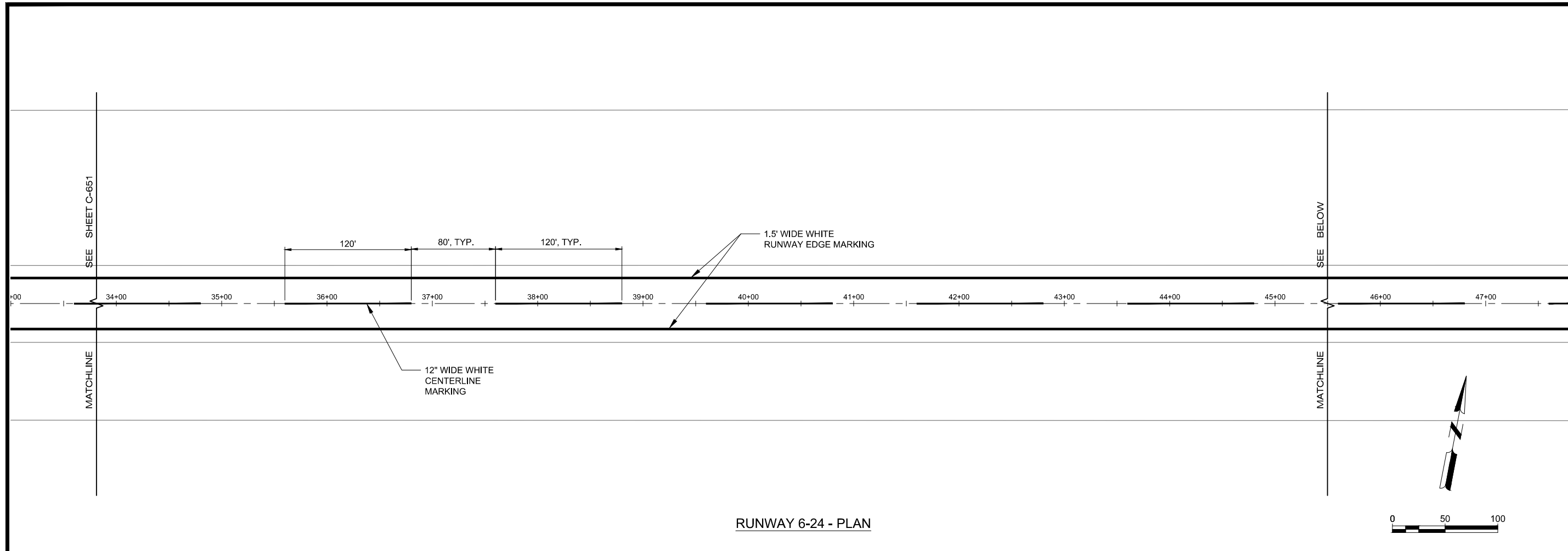

X:\3169800\01\757\TECH\DRAWINGS\C-651 MARKING PLAN.DWG
2/2/2016 2:28:34 PM

NOTE: THE "24" RUNWAY DESIGNATOR MARKINGS ARE REDUCED ± 73.5% PROPORTIONATELY IN WIDTH ONLY IN ORDER TO FIT ON THE 50'-WIDE RUNWAY PER AC 150/5340-1L, SECTIONS 2.1 AND 2.3

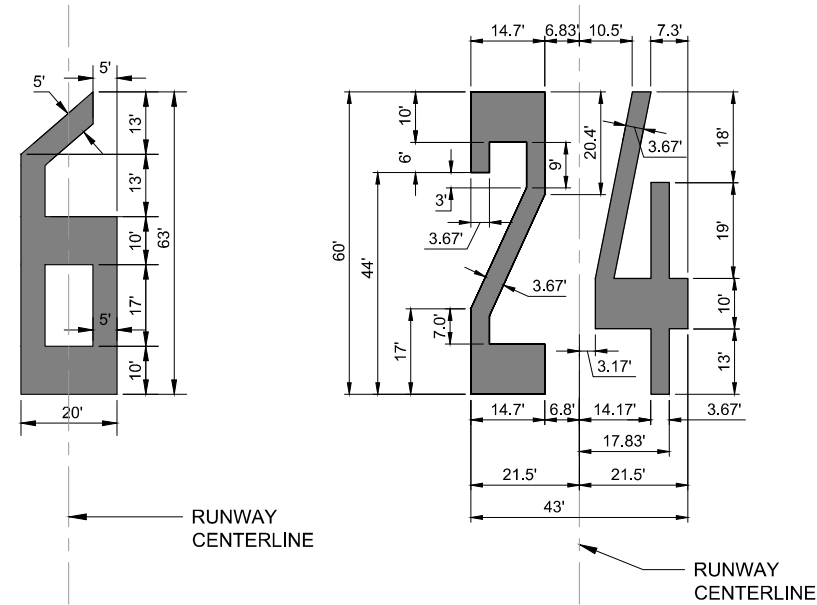

A RUNWAY NUMERALS
NO SCALE

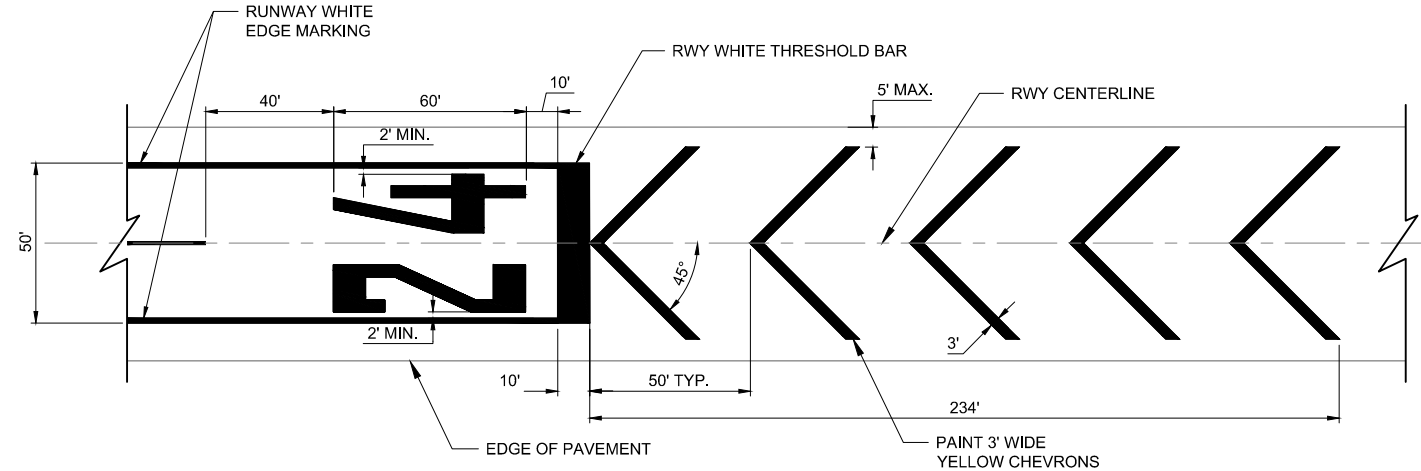

B BLAST PAD MARKING
NO SCALE

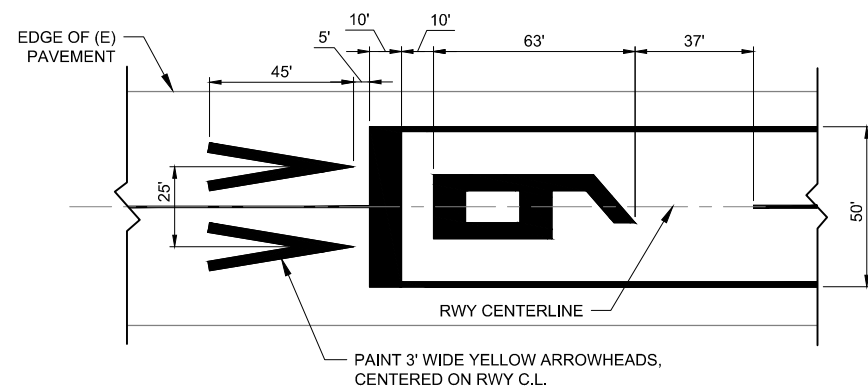

C ARROWHEAD MARKING
NO SCALE

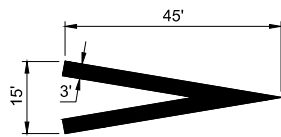

COUNTY OF RIVERSIDE

CHIRIACO SUMMIT AIRPORT RUNWAY PAVING AND GRADING

CALTRANS NO. – RIV-4-14-1

Bid Opening: May 25, 2016, at 10:00 a.m.

CONTRACT DOCUMENTS AND SPECIFICATIONS



Riverside County Board of Supervisors

Marion Ashley, Chairman
John J. Benoit, Vice Chairman
Kevin Jeffries
John F. Tavaglione
Chuck Washington

County of Riverside

3403 10th Street, Suite 400
Riverside, California 92501
(951) 955-8916
www.rivcoeda.org

Riverside County E.D.A. Aviation Division

Robert Field, Assistant County Executive Officer
Daryl Shippy, County Airport Manager

Mead & Hunt, Inc.

133 Aviation Boulevard, Ste. 100
Santa Rosa, California 95403
(707) 526-5010

April 13, 2016

BID SET

CHIRIACO SUMMIT AIRPORT RUNWAY PAVING AND GRADING PROJECT

CALTRANS NO. – RIV-4-14-1

BID DOCUMENTS

Prepared for



Prepared by:

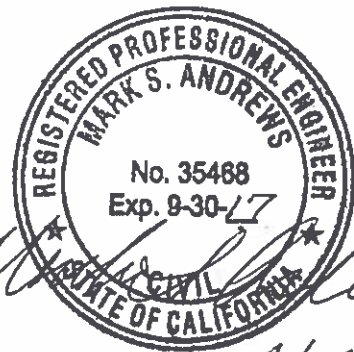

Mark S. Andrews
4/14/16

BID OPENING: MAY 25, 2016

Issued April 13, 2016

TABLE OF CONTENTS

DIVISION I – BIDDING AND CONTRACT DOCUMENTS **Page No.**

Advertisement for Bids	1
Instructions to Bidders.....	4

Proposal Forms

Proposal Form, including Bid Schedule	16
List of Subcontractors	18
Non-Collusion Affidavit.....	19
Affidavit for Individual Contractors	21
Affidavit for Joint Venture of Co-partnership Contractor	22
Affidavit for Corporate Contractor	23
Bid Bond.....	24

Sample Forms

Contract Agreement.....	26
Performance Bond	28
Payment Bond.....	29

DIVISION II – GENERAL PROVISIONS

1.1 Authorities and Limitations	31
1.2 Legal Requirements	31
1.3 Standard References	32
1.4 Permits, Licenses, Fees and Taxes.....	32
1.5 Separate Contracts	32
1.6 County’s Authorized Representative, Inspector(s), and Engineer	33
2.1 Bonds and Insurance	34
3.1 Site Conditions	37
4.1 Specifications and Drawings.....	39
5.1 Clarification/Request for Information and Additional Instructions	40
6.1 Qualification for Employment and Apprenticeship Standards	41
6.2 Wages and Records	41
6.3 Notice of Labor Disputes.....	42
6.4 Nondiscrimination.....	42
7.1 Fair Employment Practices	44
7.2 Labor Code	46
8.1 Subcontractors	49
8.2 Relations of Contractor and Subcontractor	49
8.3 Subcontracts	49
9.1 Sales and Payroll Taxes	50
10.1 Change Order Work	51
10.2 Change Orders and Labor Rates Guidelines.....	53
10.3 Audit	54
11.1 Non-Compliance with Contract Requirements.....	54
11.2 Termination	55
12.1 Time of Work.....	57
12.2 Unavoidable Delays	57
12.3 Request for Time Extension.....	58

13.1	Supervision and Construction Procedures.....	59
13.2	Supervision	59
13.3	Conduct of Work	60
13.4	Contractor's Responsibility for Work and Property	60
13.5	Utilities.....	60
13.6	Working Hours	60
13.7	Material and Equipment	61
13.8	Use of Premises.....	61
13.9	Operations and Storage.....	61
13.10	Heat/Power/Light.....	62
14.1	Accident Prevention	62
14.2	Responsibility for Compliance with CAL-OSHA.....	62
14.3	Toxic and Hazardous Materials and Waste	63
15.1	County-Furnished Property	63
16.1	Beneficial Occupancy.....	64
17.1	Inspection and Testing.....	64
17.2	Inspection by other Jurisdictions	65
17.3	Final Inspection and Tests	65
18.1	Acceptance of the Work.....	66
19.1	Contractor's Warranty and Guarantee	66
20.1	Environmental Protection	67

DIVISION III – SPECIAL PROVISIONS

Section 1	Terms, Definitions, Abbreviations, and Symbols	71
Section 2	Scope and Control of the Work.....	75
Section 3	Control of Materials	76
Section 4	Utilities.....	79
Section 5	Prosecution, Progress, and Acceptance of Work	80
Section 6	Measurement and Payment.....	80

DIVISION IV – TECHNICAL SPECIFICATIONS

A-100	Miscellaneous Provisions for Airport Safety and Construction	85
A-105	Mobilization.....	88
P-101	Surface Preparation.....	90
P-603	Bituminous Tack Coat	94
Caltrans Chapter 39	Hot Mixed Asphalt Concrete	97
P-620	Runway and Taxiway Marking	137

Appendix 1 - Construction Safety and Phasing Plan

DIVISION I

Bidding and Contract Documents

**ADVERTISEMENT FOR BIDS
CHIRIACO SUMMIT AIRPORT
RUNWAY PAVING AND GRADING
CALTRANS NO. RIV-4-14-1**

Sealed proposals for the construction of airport improvements at Chiriaco Summit Airport will be received at the offices of the Clerk of the Board of Supervisors for the County of Riverside, 4080 Lemon Street, First Floor, Riverside, California 92501 until **10:00 a.m. (PST), May 25, 2016**, and then will be publicly opened and read.

DESCRIPTION OF WORK

- Runway 6-24 Pavement Overlay
- Surface Preparation
- Pavement Marking Removal
- Crack Repairs
- Application of Pavement Marking

BID DOCUMENTS

Complete digital Project Bidding Documents (Plans, Specifications, and Bid Documents) for the Project are available online from Quest Construction Data Network (Quest CDN) at www.questcdn.com. Interested parties may download the digital documents for twenty dollars (\$20.00) by inputting **Quest Project #4368064** on the Project Search page. Those downloading the bidding documents electronically do so at their own risk for completeness of documents. Please contact Quest CDN at (952)233-1632 or info@questcdn.com for assistance in free membership registration, downloading, and working with this digital project information. (The Documents may also be previewed online prior to ordering at no charge via Quest CDN as specified above.)

Each bidder must supply all the information required by the Bid Documents and specifications. Bidders shall provide prices for all the items in the bid schedule. Each bid shall be in accordance with the plans and specifications and other Contract Documents on file at the Riverside County Economic Development Agency, 1325 Spruce Street, Suite 400, Riverside, California 92507.

All proposals sent by mail must be posted so as to be in the hands of the County of Riverside, by the hour and date set forth above for the bid opening. Bidding will not be held electronically.

The County reserves the right to award the Contract to the lowest responsive and responsible base bid depending on the availability of funds.

Each proposal must be accompanied by a certified check, cashier's check, or bid bond in an amount not less than ten percent (10%) of the amount bid. The successful bidder will be required to submit at the time of execution of the Contract a Performance Bond and a Payment Bond (Labor and Material), each for 100% of the Contract price.

All proposals shall be addressed to:

**Clerk of the Board of Supervisors for the County of Riverside
4080 Lemon Street, First Floor, Riverside, California 92501**

and marked: **Chiriaco Summit Airport, Runway Paving and Grading
CALTRANS NO. RIV-4-14-1**

PRE-BID MEETING AND WALK THROUGH

A Prebid meeting and walk-through is scheduled for **May 18, 2016, at 11:00 a.m.** PST, at Chiriaco Summit Airport. Bidders are highly encouraged to attend.

CONTRACTOR'S LICENSE

To be considered, a potential bidder must have a Class A contractor's license or a C-12 contractor's license with a combination of Class "C" Specialty Contractors License(s) sufficient to perform the work, as required under provisions of the Public Contracts Code Section 3300, and the California Business and Professions (CBP) Code 7028.15, for work covered in its proposal when a bid is submitted and throughout Contract. This includes a joint venture formed to submit a bid. Joint venture bidders must obtain a joint venture license before contract award, per CBP Code 7029.1.

CONTRACTOR REQUIREMENTS

1. Mandatory Registration.

- A. No contractor or subcontractor may be listed on a bid proposal for a public works project unless registered with the Department of Industrial Relations pursuant to Labor Code section 1725.5 (with limited exceptions from this requirement for bid purposes only under Labor Code section 1771.1(a)).
- B. No contractor or subcontractor may be awarded a contract for public work on a public works project unless registered with the Department of Industrial Relations pursuant to Labor Code section 1725.5.
- C. This project is subject to compliance monitoring and enforcement by the Department of Industrial Relations.

2. Payroll Records.

The contractor must comply with the provisions of Labor Code Section 1776 regarding payroll records, which includes forms, retention, provisions electronically, and new provisions for response to Public Records requests.

3. Job Site Notices.

The prime contractor will be required to post job site notices prescribed by regulation, related to wages, hours, and working conditions and any other postings required for specific workplace.

4. List of Subcontractors

The prime contractor must provide a list of subcontractors with his bid on the form provided in the Proposal forms.

PREVAILING WAGES: - Pursuant to Section 1773 of the Labor Code, the general prevailing wage rates, including the per diem wages applicable to the work, and for holiday and overtime work, including employer payments for health and welfare, pension, vacation, and similar purposes, in the County of Riverside in which the work is to be done, have been determined by the Director of the Department of Industrial Relations, State of California. These wages are set forth in the General Prevailing Wage Rates for this project, available from the California Department of Industrial Relations' Internet web site at www.dir.ca.gov. Future effective prevailing wage rates that have been predetermined and are on file with the California Department of Industrial Relations are referenced but not printed in the general prevailing wage rates.

NON-DISCRIMINATION: It is the policy of Riverside County to practice nondiscrimination based on race, color, sex, or national origin in the award or performance of this contract. All firms qualifying under this solicitation are encouraged to submit bids/proposals.

SUBSTITUTE SECURITIES (PCC § 22300): As provided for in Section 22300 of the California Public Contract Code, the Contractor (awarded) may substitute securities for any monies withheld by the County to ensure performance under the contract.

COUNTY RIGHTS: The County reserves the right to reject any and all bid proposals (in accordance with Section 20150.9 of the California Public Contracts Code) and to waive any technical irregularities; to accept any bid or portion thereof, and to take all bids under advisement for a period of up to ninety (90) days.

Date: _____

By: _____

INSTRUCTIONS TO BIDDERS

All services rendered under this contract shall conform to the State of California Standard Specifications published by the Department of Transportation, the FAA Advisory Circular 150-5370-10G "Standards for Specifying Construction of Airports," and the Standard Specifications for Public Works (the "Green Book") as modified in this document, including Supplements thereof, are incorporated into this contract by this reference except to the extent that they are explicitly or implicitly superseded or amended by provisions of this instrument.

1. PROJECT INFORMATION

- A. General.** General and technical information can be obtained from the offices of Mead & Hunt, 133 Aviation Blvd., Suite 100, Santa Rosa, California 95403; phone (707) 526-5010. Contact: Brett Siweck, Project Engineer; email: Brett.Siweck@meadhunt.com.
- B. Disabled Veteran Business Enterprises.** Take necessary and reasonable steps to ensure that DVBEs have the opportunity to participate in the Contract. Comply with Mil & Vet Code § 999 et seq.
- C. Small Business and Non-Small Business Subcontractor Preferences.** The County applies small business preferences and non-small business preferences under Govt Code § 14835 et seq. and 2 CA Code of Regs § 1896 et seq.

Any contractor, subcontractor, supplier, or service provider who qualifies as a small business is encouraged to apply for certification as a small business by submitting its application to the Department of General Services, Office of Small Business and DVBE Services. Contract award is based on the total bid, not the reduced bid.

- D. California Companies.** Under Pub Cont Code § 6107, the County gives preference to a California company, as defined, for bid comparison purposes over a nonresident contractor from any state that gives or requires a preference to be given to contractors from that state on its public entity construction contracts. Complete a California Company Preference form.

The California company reciprocal preference amount is equal to the preference amount applied by the state of the nonresident contractor with the lowest responsive bid unless the California company is eligible for a small business preference or a non-small business subcontractor preference, in which case the preference amount is the greater of the two, but not both.

If the low bidder is not a California company and a California company's bid with reciprocal preference is equal to or less than the lowest bid, the Department awards the contract to the California company on the basis of its total bid.

2. BID PROPOSAL REQUIREMENTS

- A. Bid Proposal Preparation and Submission.** Bid Proposals shall be submitted to the Riverside County Economic Development Agency.D.A (EDA). Aviation Division, hereinafter, the "COUNTY," on forms prepared and furnished for the purpose, which are included in Division I of these Contract Documents. When submitted they must be completely filled out in the manner and form indicated therein, showing

the proposed prices clearly and legibly, and must be properly signed by an authorized representative of the bidder. Bid Proposals presented otherwise may not be considered.

All Bid Proposals should all be made in accordance with these documents and as indicated in the provisions of the Standard Specifications for Public Works Construction, Latest Edition. Each Bid Proposal so submitted, together with the required Bid Proposal guaranty (Bid Bond) hereinafter prescribed, shall be submitted in sealed envelopes bearing on the outside the name of the bidder, his address, and the name of the project for which the Bid Proposal is submitted, and addressed to the designated address as stated in the Advertisement for Bids. It is the sole responsibility of the Bidder to see that the Bid Proposal is received in proper time. Any Bid Proposal received after the scheduled closing date and time for receipt of Bid Proposals will be returned to the Bidder unopened

All Bid Proposals submitted, as aforementioned prescribed will be publicly opened and read at the time and place indicated in the Notice Inviting Sealed Bid Proposals Advertisement for Bids.

B. Withdrawal of Bid Proposals: A Bid Proposal so presented, however, may be withdrawn by the bidder, provided the request therefore is made in writing, is signed by the bidder or his authorized representative, and is filed prior to the time fixed for the opening of bids. A request for withdrawal may be sent by fax. The withdrawal of a Bid Proposal does not prejudice the right of the bidder to file a new Bid Proposal within the time period allowed.

C. Bid Proposal Forms Instructions and Information:

- 1) Bid Proposals are required for the entire work: The amount of the Bid Proposal for comparison purposes will be the total of all items.

The bidder shall set forth for each item of work, in clearly legible figures, a unit price and a total for the item in the respective spaces provided for this purpose. In the case of the unit price items, the amount set forth under the "Total" column shall be the extension of the unit price bid on the basis of the estimated quantity for the item.

In case of discrepancy between the unit price and the total set forth for the item, the unit price shall prevail; provided, however, if the amount set forth as a unit price is ambiguous, unintelligible or uncertain for any cause, or is omitted, or in the case where the unit price is the same amount as the entry in the "Total" column, then the amount set forth in the "Total" column for the item shall prevail in accordance with the following:

- (a) As to lump sum items, the amount set forth in the "Total" column shall be the unit price.
- (b) As to unit price items, the amount set forth in the "Total" column shall be divided by the estimated quantity for the item and the price thus obtained shall be the unit price.

- 2) Taxes: No mention shall be made of Sales Tax or Use Tax as all bid prices submitted will be considered to include such taxes.

- 3) Quantities: The quantities shown in the Bid Proposal form, and in the estimate included in the Specifications, shall be considered as approximate only, being listed therein for the purpose of serving as a general indication of the amount of work or materials to be performed or furnished, and as a basis for the comparison of Bid Proposals and the COUNTY does not guarantee nor agree, either expressly or by implication, that the actual amounts required will correspond therewith, but

reserves the right to increase or decrease the amount of any item or portion of work or material to be performed or furnished, or to omit any such item or portion, in accordance with the provisions relative thereto set forth in the Special Provisions or Standard Specifications, under which the work is to be constructed, without in any way invalidating the contract, should such increase, decrease or omission be deemed necessary or expedient.

- 4) Listing Subcontractors: Each bidder shall submit a list of the proposed subcontractors on this project as required by the Subletting and Subcontracting Fair Practices Act (Gov. Code Sec. 4100 and following). Forms for this purpose are furnished with the proposal documents.
- 5) “Or Equal”: All specifications shall be deemed to include the words “or equal;” provided however that permissible exceptions hereto shall be specifically noted in the specifications.
- 6) Competency: Bidders must be thoroughly competent, and capable of satisfactorily performing the work covered by the Bid Proposal; and when requested shall furnish such statements relative to previous experience on similar work, the plan of procedure proposed, and the organization, machinery, plant and other equipment available for the contemplated work, and the financial condition and resources of the Bidder, as may be deemed necessary by the COUNTY in determining such competence and capability.
- 7) Contractor’s License: The required Contractor’s license for this project is: **California Class A or California Class C-12, with a combination of Class C Specialty Contractor’s License(s)**. Each Bidder shall be licensed as a Contractor in accordance with the provisions of Chapter 9 of Division 3 of the Business and Professions Code at the time of submitting his Bid Proposal. The signature in the Bid Proposal shall clearly show the Bidder’s name, address, telephone number, valid State of California Contractor’s License number, and proper license class to perform the work under the contract. The same requirements shall apply to subcontractors. Any Bid Proposal submitted which does not show the above information may be considered an incomplete Bid Proposal and rejected as such.
- 8) Altering Bid Proposals: The wording of the Bid Proposal forms shall not be changed. Any additions, conditions, limitations, or provisions inserted by the bidder will render the Bid Proposal irregular and may cause its rejection. Erasures or interlineations in the Bid Proposal must be explained or noted over the signature of the bidder.

Changes in or additions to the Bid Proposal form, recapitulations of the work bid upon, alternative Bid Proposals or any other modifications of the Bid Proposal form that are not specifically called for in the contract documents may result in the COUNTY’S rejection of the Bid Proposal as not being responsive to the invitation to bid. No oral or telephonic modification of any Bid Proposal submitted will be considered. The Bid Proposal submitted must not contain any erasures, interlineations, or other corrections unless each such correction is suitably authenticated by affixing in the margin immediately opposite the correction the surname or surnames of the person or persons signing the Bid Proposal. A Bid proposal which is incomplete or shows any alteration of form, erasures or irregularities of any kind, or contain any additions or conditional or alternate bids that are not called for or otherwise permitted, may be rejected. A Bid Proposal on which the signature of the bidder has been omitted may, be rejected.

- 9) Discrepancies in Bid Proposals: If the amounts bid on individual items (if called for) do not in fact add to the total amount shown by the bidder, the correctly added total of the individual items shall prevail over the total figure shown. The estimated quantities and amounts are for the purpose of comparison of Bid Proposals only. The COUNTY reserves the right to reject any or all Bid

Proposals and to waive any irregularity or informality in any Bid Proposals to the extent permitted by law.

- 10) Acceptance or Rejection of Bid Proposals: The COUNTY reserves the right to reject any or all Bid Proposals and to waive any informality or defects in Bid Proposals received as in the best interests of the COUNTY.
 - (a) Bid Proposals in which the bid prices are obviously unbalanced may be rejected.
 - (b) Bid Proposals in which a bid item is left totally blank will be considered as being non-responsive and rejected.
- 11) Disqualification of Bidders: The successful Bidder must be responsive and responsible. More than one Bid Proposal for the same work from any individual, firm, partnership, corporation, or association under the same or different names, will not be accepted; and reasonable grounds for believing that any bidder is interested in more than one Bid Proposal for the work will be cause for rejecting all Bid Proposals in which such bidder is interested. Apparent collusion among bidders will likewise be sufficient cause for rejecting any or all Bid Proposals and the participants in such collusion may be barred from future bidding.

The COUNTY reserves the right to find a Bid Proposal of a Bidder who has been delinquent, is in current litigation with the COUNTY or has been within the preceding 12 months or was unfaithful in any former contract with the COUNTY non-responsive. No Bidder may withdraw his Bid Proposal for a period of sixty days after the date of the Bid Proposal opening.

3. BID PROPOSAL GUARANTY: Each Bid Proposal submitted must be accompanied either by cash, or by a certified or cashier's check, or a surety bond, payable to the COUNTY in an amount equivalent to at least ten percent (10%) of the total aggregate bid price of such Bid Proposal, or in such additional amount as may be otherwise provided by law, as a guarantee that the bidder, if his Bid Proposal be accepted, will promptly execute the contract, secure payment of Worker's Compensation Insurance, furnish a satisfactory Faithful Performance Bond in the amount of one hundred percent (100%) of the total bid price, and a Labor and Material Bond in the amount of one hundred percent (100%) of the total bid price. No Bid Proposal will be accepted unless such cash check or surety bond is enclosed therewith. The Bid Proposal bond shall be executed by the bidder and a financially sound surety company authorized to transact business in this state as a "California admitted insurer". Each bidder shall identify the surety company that will furnish payment/performance bonds if awarded the contract.

Should any bidder to whom an award is made fail to properly enter into and execute the awarded contract, the cash, check or bond submitted with its Bid Proposal shall be forfeited to, and become the property of the COUNTY; whereupon the COUNTY shall have the right to collect the amount thereof by any appropriate means.

Following the award of the contract the Bid Proposal guarantees will be returned to the respective bidders by whom they were submitted, except as otherwise provided.

4. PRE-BID MEETING: A mandatory prebid meeting and walk-through is scheduled for May 18, 2016, at 11:00 a.m. at the airport site located 700 feet N.E of Chiriaco Summit Post Office, CA. At this time, bidders must satisfy themselves by personal examination of the location of the proposed work and by such other means as they may prefer as to the actual conditions and requirements of the work, and shall not at any time after submission of the Bid Proposal dispute, complain, or assert that there was any misunderstanding in regard to the nature or amount of work to be done.

5. BIDDER'S EXAMINATION OF SITE AND CONTRACT DOCUMENTS: Each bidder shall examine carefully the site of the proposed work and the contract documents therefore. By submitting a Bid Proposal it will be assumed that the bidder has investigated and is satisfied as to the conditions to be encountered as to the character, quality, and quantity of materials to be furnished, and as to the requirements of the contract, specifications and drawings; and to have satisfied himself as to his ability to meet requirements attendant the execution of the proposed contract before the delivery of his Bid Proposal, and agrees that if he is awarded the contract, he will make no claim against the COUNTY based on ignorance or misunderstanding of the contract provisions. It is mutually agreed that submission of a Bid Proposal shall be considered prima facie evidence that the bidder has made such examination.

6. INTERPRETATION OF DRAWINGS AND DOCUMENTS:

If any Bidder contemplating submitting a Bid Proposal for the proposed contract is in doubt as to the true meaning of any part of the Plans, Specifications, or other Contract Documents, or finds discrepancies in or omissions from the Plans and Specifications, questions or request for information / clarification may be submitted in writing to the Engineer not later than **three (3) working days** before the date set for receipt of bids. The person submitting the request will be responsible for its prompt delivery. Any interpretation or correction of the Contract Documents will be made only by Addendum and will be e-mailed, faxed, mailed or delivered to each person receiving a set of such documents. Inquiries received after **May 20, 2016, at 1:00 p.m. PST**, will not be answered. Bid must acknowledge any issued addenda by signature where provided on the proposal form and included with the bid submission. Verbal interpretations are not to be relied upon. **FAILURE OF THE BIDDER TO CALL ATTENTION TO IRREGULARITIES OR LACK OF CLARITY WILL NOT RELIEVE THE BIDDER OF PERFORMANCE UNDER THE CONTRACT.**

7. BID EVALUATION AND AWARD OF CONTRACT

A. Evaluation: Bids will be evaluated for price, conformance to the Plans, Specifications, Bid Documents, experience, and other factors as appropriate.

Each Bid Schedule and Alternates (if applicable) will be evaluated separately. The bid price for each Contract item shall include all costs associated with completing the work included in the item and only those costs. Profit and overhead shall be factored into each item.

After the Bid Proposals for the contemplated work have been opened and read as provided herein, the respective totals thereof, determined by applying the unit prices bid to the estimated quantities shown, will be extended and compared; and the results will thereupon be made public.

B. Award: The COUNTY reserves the right to reject any and all bids. The award of the contract, if any, will be made to the lowest responsive and responsible bidder whose Bid Proposal complies with all the prescribed requirements, but until an award is made the right will be reserved to reject any or all Bid Proposals, in conformance with Section 20150.9 of the California Public Contracts Code, or to waive technical errors or discrepancies, or to take any other actions allowed by law, if to do so is deemed to best serve the interests of the COUNTY. In no event will an award be made until all necessary investigations are made as to the responsibility qualifications and responsiveness of the bidder to whom it is proposed to make such award.

All bids shall be valid for a period of ninety (90) working days from the opening date.

1) Responsive bidder: A responsive bid conforms to all significant terms and conditions contained in the COUNTY's invitation for bid and contract documents. It is the COUNTY's responsibility to

decide if the exceptions taken by a bidder to the solicitation are material or not and the extent of deviation it is willing to accept.

- 2) **Responsible bidder:** A responsible bidder has the ability to perform successfully under the terms and conditions of a proposed procurement. This includes such matters as Contractor integrity, compliance with public policy, record of past performance, and financial and technical resources. In the event the COUNTY determines that the lowest responsive bidder is not also a responsible bidder, that bidder may be entitled to a hearing if requested and as required by law.

8. BID DEPOSIT RETURN: Deposits by of three or more low bidders for the project, on each alternate, the number being at the discretion of the COUNTY, will be held for ninety (90) days or until posting by the successful bidder of the Bonds required and return of executed copies of the Agreement, whichever first occurs, at which time the deposits will be required after consideration of the bids.

9. EVIDENCE OF RESPONSIBILITY: Upon the request of the COUNTY, a bidder whose Bid Proposal is under consideration for the award of the contract shall submit promptly to the COUNTY satisfactory evidence showing the bidder's financial resources, his construction experience, and his organization and plant facilities available for the performance of the contract.

10. BID PROTEST PROCEDURES: Any protest of the proposed award of bid to the bidder deemed the lowest responsible bidder must be submitted in writing to the COUNTY no later than 5:00 PM on the third business day following the date of the bid opening.

The initial protest must contain a complete statement of the basis for the protest.

The protest must state the facts and refer to the specific portion of the document or the specific statute that forms the basis for the protest. The protest must include the name, address, and telephone number of the person representing the protesting party.

The party filing the protest must concurrently transmit a copy of the initial protest to the bidder deemed the lowest responsible bidder.

The party filing the protest must have actually submitted a bid on the project. A subcontractor of a party filing a bid on this project may not submit a Bid Protest. A party may not rely on the Bid Protest submitted by another bidder, but must timely pursue its own protest.

The procedure and time limits set forth in this Section are mandatory and are the bidder's sole and exclusive remedy in the event of a Bid Protest. The bidder's failure to fully comply with these procedures shall constitute a waiver of any right to further pursue the Bid Protest, including filing of a challenge of the award pursuant to the California Public Contracts Code, filing of a claim pursuant to the California Government Code, or filing of any other legal proceedings.

The COUNTY shall review all timely protests prior to formal award of the bid. The COUNTY shall not be required to hold an administrative hearing to consider a timely protest, but may do so at the option of the Director, or if otherwise legally required. At the time of the COUNTY'S Board of Supervisors consideration of the award of the bid, the COUNTY'S Board of Supervisors may also consider the merits of any timely protests and the Director's recommendation thereon. The COUNTY'S Board of Supervisors may either accept the protest and award the bid to the next lowest responsible bidder, or reject the protest and award to

the lowest responsible bidder. Nothing in this section shall be construed as a waiver of the COUNTY'S Board of Supervisors right to reject all bids, to rebid the project, to perform the work by force account or waive technical irregularities.

11. TIME OF COMPLETION AND LIQUIDATED DAMAGES:

A. Time: Successful Bidder ("Contractor") must agree to commence work on the date of the written "Notice to Proceed" from Caltrans and the of the COUNTY and to fully complete the project in accordance with the proposed construction schedule as defined in Division IV, Item A-100 "Operational Safety for Airport Construction" and Appendix 1, "Construction Safety and Phasing Plan" of these Specifications.

The anticipated schedule is as follows:

Award Contract:	June 21, 2016
Pre-Construction Meeting:	July 5, 2016
Notice to Proceed:	July 7, 2016
Construction Start Date	August 3, 2016
Completion Date:	August 24, 2016

B. Liquidated Damages: This Project is subject to liquidated damages if time limitations are not met. Details are in Division IV, Item A-100 "Miscellaneous Provisions for Airport Safety and Construction" and Appendix 1, "Construction Safety and Phasing" of these Specifications. Contractor must agree also to pay as liquidated damages, the sum of One Thousand Five Hundred dollars (\$1,500) for each calendar day thereafter as defined in Division IV, Item A-100, "Miscellaneous Provisions for Airport Safety and Construction" of these Specifications. Other time limitations may apply for airport construction. See the Miscellaneous Provisions and the Construction Safety and Phasing Plan for details.

12. BONDS: The successful Bidder (Contractor) shall secure with a responsible corporate surety, or corporate sureties, satisfactory bonds conditioned upon faithful performance by the Contractor of all requirements under the contract and upon the payment of claims of materials, men and laborers thereunder. The faithful performance bond shall be in the sum of not less than one hundred percent (100%) of the estimated aggregate amount of the payments to be made under the contract computed on the basis of the prices stated in the proposal. The labor and material bond shall be in the sum of not less than one hundred percent (100%) of the estimated aggregate amount of the payments to be made under the contract computed on the basis of the prices stated in the proposal.

13. EXECUTION OF CONTRACT: The agreement shall be signed by the awardees and returned to the COUNTY together with the contract bonds, and other contract documents as required in the Bid Documents, within ten (10) business days after it has been delivered or mailed to him or his authorized agent.

No Bid Proposal shall be considered as being binding upon the COUNTY until the contract is fully executed; any failure of the awardees to properly execute the awarded contract and file acceptable bonds as provided in the Standard Specifications, shall be just and sufficient cause for the annulment of the award by the COUNTY and the forfeiture of his Bid Proposal guaranty.

14. EMPLOYMENT OF APPRENTICES: The CONTRACTOR, and all subcontractors, shall comply with the provisions in Sections 1777.5, (Chapter 1411, Statutes of 1968), and 1777.6 of the California Labor Code concerning the employment of apprentices. The CONTRACTOR and any subcontractor under him shall comply with the requirements of said sections in the employment of apprentices; however, the CONTRACTOR shall have full responsibility for compliance with said Labor Code section, for all apprentice able occupations, regardless of any other contractual or employment relationships alleged to exist. In addition to the above State Labor Code Requirements regarding the employment of apprentices and trainees, the CONTRACTOR and all subcontractors shall comply with Sections 5 a. 3, Title 29 of the Code of Federal Regulations (29CFR) if applicable.

15. PERMITS, FEES, AND LICENSES: The CONTRACTOR shall possess valid business licenses as stated in Instructions to Bidders. The CONTRACTOR must also secure a permit from the County of Riverside.

16. QUANTITIES: The quantity of work for the unit price items to be done under the contract, as noted in the Schedule of Prices, is an estimate and is not to be taken as an expressed or implied statement that the actual quantity of work will correspond to the estimate.

The right is reserved by the COUNTY to increase or decrease or to entirely eliminate items from the work if found desirable or expedient.

The CONTRACTOR will not be allowed any claims for anticipated profits, loss of profits or for any damages of any sort because of any difference between the estimated and actual quantities of work done or for work decreased or eliminated by the COUNTY.

17. ADDENDA TO CONTRACT DOCUMENTS: The COUNTY Director may, from time to time, issue addenda to the contract documents during the period of advertising for Bid Proposals, for the purpose of clarifying or correcting Plans, Specifications, or other bid documents.

Purchasers of contract documents will be furnished with copies of such addenda, either by first class mail, electronic email, or personal delivery, during the period of advertising. Any addenda will be sent to the address of the purchaser of the contract documents furnished to QuestCDN.com at the time the purchase was made.

18. REQUIRED NOTIFICATIONS: The Contractor shall notify the COUNTY and the owners of all utilities and substructures not less than 72 hours prior to starting construction. The Contractor shall notify the utility companies (to include telephone, water, gas, electric, etc.), and adjacent properties in writing of the project with copies of the letters sent to the COUNTY.

19. TEMPORARY SUSPENSION OF WORK: The COUNTY shall have the authority to suspend the work wholly or in part, for such a period as it may deem necessary, due to unsuitable weather, or to such other conditions as are considered unfavorable for the suitable prosecution of the work, or for such time as it may deem convenient due to failure on the part of the Contractor to carry out orders given or to perform any provisions of the work. The Contractor shall immediately obey such order and shall not resume the work until so ordered in writing by the COUNTY.

20. CONFERENCES AND MEETINGS: When and as directed by the COUNTY, the Contractor shall attend all conferences and meetings that the COUNTY deems necessary for the proper progress of work

under this contract. A weekly meeting will be held to discuss project and progress; Contractor shall provide a schedule update at the weekly meeting.

21. COOPERATION WITH OTHERS: Utility owners, contractors of the COUNTY, or contractors authorized by the COUNTY responsible for facilities located within the limits of work shall have the right to enter upon the limits of work and upon any structure therein for the purpose of making new installations, changes, or repairs, and the Contractor shall so conduct his operations as to provide the time needed for such work to be accomplished during the progress of the improvement.

22. MODIFICATIONS AND ADDITIONS: The COUNTY may, if it deems necessary, make modifications to the Specifications and plans for the work, covering any portion under such altered or modified work shall be agreed upon in writing endorsed upon the original contract and signed by the proper parties to the contract. It is expressly understood and agreed that such alterations, additions, modifications or omissions shall not in any way violate or annul the contract. Whenever, during the progress of work, any additional work or change or modification in the work contracted for is agreed upon as aforesaid, such additional work or modification shall be considered and treated as though originally contracted for, and shall be subject to all the terms, conditions and provisions of the original contract.

23. DISPOSAL OF WASTE MATERIAL: All waste to be removed and other miscellaneous items that interfere with the work shall be removed and disposed of outside the boundaries of the project by the Contractor. The Contractor shall transport the material to an authorized dump site; the cost of such disposal, if any, shall be part of the bid.

24. PROTECTION OF WORK: (Cleanup and Dust Control) The Contractor shall protect and care for all work until final acceptance. Throughout the period of construction, the Contractor shall keep the site free and clean from all rubbish and debris and any unnecessary obstructions and shall promptly clean up all or any portion of the site when notified to do so by the COUNTY representative. The Contractor shall promptly remove from any parts of the working area all unused materials and debris, to the end that construction areas are returned to a clean, neat and acceptable condition at the earliest time following completion of the work in any reasonable reach. Failure on the part of the Contractor to comply with the orders of the COUNTY any or all parts of the work under contract until the unsatisfactory condition is corrected. No additional compensation or time extension will be allowed as a result of such suspension. During all phases of the construction work, the Contractor shall take precautions to abate dust nuisance by cleaning up, sweeping, sprinkling with water, or other means as necessary to accomplish results satisfactory to the COUNTY representative.

25. WATER: Refer to Division IV Item A-100, "Miscellaneous Provisions for Airport Safety and Construction."

26. INSPECTION: The COUNTY Director, or their his/her authorized agent, shall at all times have access to work during construction, and shall be furnished with every reasonable facility for ascertaining full knowledge regarding the progress, workmanship and character of materials used and employed in the work.

The inspection of the work shall not relieve the Contractor of any of his obligations to fulfill the contract as prescribed. Defective work shall be made good, and unsuitable materials may be rejected, notwithstanding the fact that such defective work and unsuitable materials have been previously overlooked by the Building Official COUNTY and accepted or estimated for payment.

The cost for any additional inspection as a result of the Contractor's failure to meet the required time for completion of these specifications may be charged to the Contractor and withheld from final payment.

27. RESPONSIBILITY OF COUNTY: The COUNTY shall not be held responsible for the care or protection of any material or parts of the work prior to final acceptance, except as expressly provided in these Specifications.

28. PAYMENTS: In accordance with the terms of the contract, the Engineer shall upon request after the completion of the contract, make an estimate of the amount of work done thereunder, and the value of such work, and the COUNTY shall pay 95% of the sum so found to be due. The COUNTY shall retain five percent (5%) of such estimated value of work done as part security for the fulfillment of this contract by the Contractor. The final payment shall not be due and payable until the expiration of thirty-five (35) days after the recordation of the Notice of Completion of the work. Partial payments based on a percentage of work completed may be approved by the COUNTY.

29. PARTIAL PAYMENTS: Partial payments based on a percentage of work completed may be approved by the COUNTY. Said payment shall be in the amount of the total value of work estimated by the Engineer at the time of the estimate, less five percent (5%) of said estimated value retained as part security for fulfillment of the contract by the Contractor, and less all previous payments made and sums to be kept or retained under the provisions of the contract.

30. FINAL PAYMENT: Final estimate of the amount of work done under the contract shall be made and the value of such work and the COUNTY shall pay the entire sum so found to be due after deducting therefrom all previous payments and all amounts to be kept and all amounts to be retained under the provisions of the contract. All prior partial payments and estimates shall be subject to correction in the final estimate and payment.

31. CERTIFIED PAYROLL. Certified payroll records shall be provided electronically to the California Department of Industrial Relations using the appropriate form provided on the DIR website and as otherwise provided in Labor Code Section 1776 as that may be amended from time to time.

32. INDEMNIFICATION: Contractor and COUNTY agree that COUNTY should, to the extent permitted by law, be fully protected from any loss, injury, damage, claim, lawsuit, cost, expense, attorney's fees, litigation costs, defense costs, court costs or any other cost arising out of or in any way related to the performance of this agreement.

Accordingly, the provisions of this indemnity provision are intended by the parties to be interpreted and construed to provide the fullest protection possible under the law to the COUNTY. Contractor acknowledges that COUNTY would not enter into this agreement in the absence of this commitment from Contractor to indemnify and protect COUNTY as set forth here.

To the full extent permitted by law, Contractor shall defend, indemnify and hold harmless COUNTY, its employees, agents and officials, from any liability, losses, expenses or costs of any kind, whether actual, alleged or threatened, actual attorney fees incurred by COUNTY, court costs, interest, defense costs including but not limited to expert witness fees and any other costs or expenses of any kind whatsoever without restriction or limitation incurred in relation to, for bodily injury (including death) or property damage, as a consequence of or arising out of or in any way attributable actually, allegedly or implied in whole or in part to Contractor's performance or failure to perform under this agreement, except those arising from the

sole negligence of willful misconduct of COUNTY. All obligations under this provision are to be paid by Contractor as incurred by COUNTY.

The obligations of Contractor under this or any other provision of this agreement will not be limited by the provisions of any workers' compensation act or similar act. Contractor expressly waives its statutory immunity under such statutes or laws as to COUNTY, its employees and officials.

Contractor agrees to obtain executed indemnity agreements with provisions identical to those set forth here in this section from each and every subcontractor, sub-tier Contractor or any other person or entity involved by, for, with or on behalf of Contractor in the performance or subject matter of this agreement. In the event Contractor fails to obtain such indemnity obligations from others as required here, Contractor agrees to be fully responsible according to the terms of this section.

Failure of COUNTY to monitor compliance with these requirements imposes no additional obligations on COUNTY and will in no way act as a waiver of any rights hereunder. This obligation to indemnify and defend COUNTY as set forth herein is binding on the successors, assigns, or heirs of Contractor and shall survive the termination of this agreement or this section.

Proposal Forms

PROPOSAL FORM

**CHIRIACO SUMMIT AIRPORT
RIVERSIDE COUNTY, CALIFORNIA**

**RUNWAY PAVING AND GRADING PROJECT
CALTRANS NO.: RIV-4-14-1**

FROM: _____

NAME OF BIDDER: _____

BUSINESS ADDRESS: _____

BUSINESS TELEPHONE: _____ AFTER-HOURS TELEPHONE _____

CONTRACTOR LICENSE NUMBER: _____

CONTRACTOR DIR¹ REGISTRATION NUMBER: _____

TO: Economic Development Agency
Aviation Division
County of Riverside
1325 Spruce Street, Suite 400
Riverside, California 92507

The undersigned, as bidder, *under penalty of perjury*, declares that the only persons or parties interested in this proposal as principals are those named herein: that this proposal is made without collusion with any other person, firm or corporation; that he has carefully examined the location of the proposed work, the proposed form of contract, the plans and specifications herein referred to; and he proposes, and agrees if this proposal is accepted, that he will contract with the County of Riverside, in the form of the Contract annexed hereto, to provide all necessary machinery, tools, apparatus and other means of construction, and to do all the work and furnish all the materials specified in the Contract, in the manner and time therein prescribed, and according to the requirements of the County as therein set forth, and that he will take in full payment therefore the following item prices, to wit:

¹ DIR – Director of Industrial Relations

BID SCHEDULE

BASE BID –RIV 4-14-1 Runway Paving and Grading

Item	Description	Unit	Est. Qty.	Unit Cost	Total Cost
1	Mobilization	LS	1	\$	\$
2	Airfield Safety and Traffic Control	LS	1	\$	\$
3	Asphalt Pavement Sawcutting	LF	102	\$	\$
4	Minor Crack Seal (>3/8" <1")	LF	2,500	\$	\$
5	Major Crack Seal (>1")	LF	500	\$	\$
6	Paint And Rubber Removal	SY	45,200	\$	\$
7	Pavement Profile Milling	SY	3,380	\$	\$
8	Surface Preparation	SY	22,700	\$	\$
9	Bituminous Tack Coat	TON	5	\$	\$
10	Hot Mixed Asphalt Caltrans, 2-Inch Overlay	TON	2,590	\$	\$
11	Pavement Marking Including Refl. Media,	SF	18,400	\$	\$
12	Pavement Marking Including Refl. Media,	SF	1,600	\$	\$
Total Bid – Items 1 through 12 in figures :					\$
Total Bid – Items 1 through 12 in In words:					

The COUNTY reserves the right to reject any single bid or all bids. The award, if made, will be to the lowest responsive Bid.

Acknowledgment of Addenda

Addendum No. Initial

 Signature/Title

 Company

 Contractor's License Number/Expiration Date

NOTE: Contractor License Number and Expiration Date stated herein are made under penalty of perjury.

LIST OF SUBCONTRACTORS FORM

PURSUANT TO THE PROVISIONS SET FORTH IN TITLE I, DIVISION 5, CHAPTER 2 (Sections 4100-4113, inclusive) of the Government Code of the State of California -- it is required that the Contractor set forth in his Bid the name and principal business address of each Subcontractor who will perform work or labor or render service to the Contractor on or about the construction. Vendors or suppliers of materials, only, are not required to be listed.

If a Contractor fails to specify a Subcontractor for any portion of the work to be performed under the Contract, on or about the construction of the project, in excess of 1/2 of 1% of the Contractor's total Bid, he shall be deemed to have agreed to perform such portion himself, using his own resources and employed personnel and he shall not be permitted to sub-contract that portion of the work, except under the conditions set forth in Section 4107 of the Government Code of the State of California. Subcontractors shall not sublet their work as a whole.

Should the Contractor violate any of the provisions of said Chapter, his so doing will be deemed a violation of his Contract and the awarding authority shall have the right to terminate the Contractor's control over the work. Upon any such violation, the Contractor may be subject to such penalties as are prescribed by Law.

Name and Address of Subcontractor	License No.	DIR License No.	Description of Work & Reference to Bid Items	Portion of Work (%)

END OF SECTION

INSTRUCTIONS FOR NONCOLLUSION AFFIDAVIT

1. This Noncollusion Affidavit is material to any contract/purchase order awarded pursuant to this bid. According to *Section 4507 of Act 57 of May 15, 1998, 62 Pa. C. S. § 4507*, governmental agencies may require Noncollusion Affidavits to be submitted with bids.
2. This Noncollusion Affidavit must be executed by the member, officer or employee of the bidder who makes the final decision on prices and the amount quoted in the bid.
3. Bid rigging and other efforts to restrain competition, and the making of false sworn statements in connection with the submission of bids are unlawful and may be subject to criminal prosecution. The person who signs the affidavit should examine it carefully before signing and assure himself or herself that each statement is true and accurate, making diligent inquiry, as necessary, of all other persons employed by or associated with the bidder with responsibilities for the preparation, approval or submission of the bid.
4. In the case of a bid submitted by a joint venture, each party to the venture must be identified in the bid documents, and an affidavit must be submitted separately on behalf of each party.
5. The term "complementary bid" as used in the affidavit has the meaning commonly associated with that term in the bidding process, and includes the knowing submission of bids higher than the bid of another firm, any intentionally high or noncompetitive bid, and any other form of bid submitted for the purpose of giving a false appearance of competition.
6. Failure to submit an affidavit with the bid proposal in compliance with these instructions may result in disqualification of the bid.

NONCOLLUSION AFFIDAVIT

Contract/Requisition No. _____

State of _____:

County of _____: s.s.

I state that I am _____ **(Title)** of _____ **(Name of Firm)** and that I am authorized to make this affidavit on behalf of my firm, and its owners, directors, and, officers. I am the person responsible in my firm for the price(s) and the amount of this bid.

I state that:

(1) The price(s) and amount of this bid have been arrived at independently and without consultation, communication or agreement with any other contractor, bidder or potential bidder.

(2) Neither the price(s) nor the amount of this bid, and neither the approximate price(s) nor approximate amount of this bid, have been disclosed to any other firm or person who is a bidder or potential bidder, and they will not be disclosed before bid opening.

(3) No attempt has been made or will be made to induce any firm or person to refrain from bidding on this contract, or to submit a bid higher than this bid, or to submit any intentionally high or noncompetitive bid or other form of complementary bid.

(4) The bid of my firm is made in good faith and not pursuant to any agreement or discussion with, or inducement from, any firm or person to submit a complementary or other noncompetitive bid.

(5) _____ **(Name of Firm)** its affiliates, subsidiaries, officers, directors, and employees are not currently under investigation by any governmental agency and have not in the last four years been convicted or found liable for any act prohibited by state or federal law in any jurisdiction, involving conspiracy or collusion with respect to bidding on any public contract, except as follows:

I state that _____ **(Name of Firm)** understands and acknowledges that the above representations are material and important, and will be relied on by _____ **(Name of Purchasing Agency)** in awarding the contract(s)/ purchase order(s) for which this bid is submitted. I understand and my firm understands that any misstatement in this affidavit is and shall be treated as fraudulent concealment from the Purchasing Agency of the true facts relating to the submission of this bid.

(Signature)

(Signatory's Name)

(Signatory's Title)

SWORN TO AND SUBSCRIBED
BEFORE ME THIS _____ DAY
OF _____ 20____

_____ My Commission

Expires _____
Notary Public

AFFIDAVIT FOR INDIVIDUAL CONTRACTORS

_____ declares as follows:

That he or she is the party making the foregoing proposal or bid; that the bid is not made in the interest of, or on behalf of, any undisclosed person, partnership, company, association, organization, or corporation; that the bid is genuine and not collusive or sham; that the bidder has not directly or indirectly induced or solicited any other bidder to put in a false or sham bid, and has not directly or indirectly colluded, conspired, connived, or agreed with any bidder or anyone else to put in a sham bid, or that anyone shall refrain from bidding; that the bidder has not in any manner, directly or indirectly, sought by agreement, communication, or conference with anyone to fix the bid price of the bidder or any other bidder, or to fix any overhead, profit, or cost element of the bid price, or of that of any other bidder, or to secure any advantage against the County of Riverside or anyone interested in the proposed CONTRACT; that all statements contained in the bid are true; and, further, that the bidder has not, directly or indirectly, submitted his or her bid price or any breakdown thereof, or the contents thereof, or divulged information or data relative thereto, or paid, and will not pay, any fee to any corporation, partnership, company, association, organization, bid depository, or to any member or agent thereof to effectuate a collusive or sham bid.

I declare, under penalty of perjury, that the foregoing is true and correct.

**Dated this _____ day of _____, 2016, at _____,
California.**

Signature of affiant: _____

NOTE: Notarization of signature required

AFFIDAVIT FOR JOINT VENTURE OF COPARTNERSHIP CONTRACTOR

_____ declares as follows:

That he or she is a member of the joint venture or copartnership firm designated as

which is the party making the foregoing proposal or bid; that the bid is not made in the interest of, or on behalf of, any undisclosed person, partnership, company, association, organization, or corporation; that the bid is genuine and not collusive or sham; that the bidder has not directly or indirectly induced or solicited any other bidder to put in a false or sham bid, and has not directly or indirectly colluded, conspired, connived, or agreed with any bidder or anyone else to put in a sham bid, or that anyone shall refrain from bidding; that the bidder has not in any manner, directly or indirectly, sought by agreement, communication, or conference with anyone to fix the bid price of the bidder or any other bidder, or to fix any overhead, profit, or cost element of the bid price, or of that of any other bidder, or to secure any advantage against the County of Riverside or anyone interested in the proposed CONTRACT; that all statements contained in the bid are true; and, further, that the bidder has not, directly or indirectly, submitted his or her bid price or any breakdown thereof, or the contents thereof, or divulged information or data relative thereto, or paid, and will not pay, any fee to any corporation, partnership, company, association, organization, bid depository or to any member or agent thereof to effectuate a collusive or sham bid.

That he has been and is duly vested with authority to make and sign instruments for the joint venture or copartnership by _____

who constitute the other members of the joint venture or copartnership.

I declare, under penalty of perjury, that the foregoing is true and correct.

**Dated this _____ day of _____, 2016, at _____,
California.**

Signature of affiant: _____

NOTE: Notarization of signature required

AFFIDAVIT FOR CORPORATE CONTRACTOR

_____ declares as follows:

That he or she is _____
of _____

a corporation which is the party making the foregoing proposal or bid; that the bid is not made in the interest of, or on behalf of, any undisclosed person, partnership, company, association, organization, or corporation; that the bid is genuine and not collusive or sham; that the bidder has not directly or indirectly induced or solicited any other bidder to put in a false or sham bid, and has not directly or indirectly colluded, conspired, connived, or agreed with any bidder or anyone else to put in a sham bid, or that anyone shall refrain from bidding; that the bidder has not in any manner, directly or indirectly, sought by agreement, communication, or conference with anyone to fix the bid price of the bidder or any other bidder, or to fix any overhead, profit, or cost element of the bid price, or of that of any other bidder, or to secure any advantage against the County of Riverside or anyone interested in the proposed CONTRACT; that all statements contained in the bid are true; and further, that the bidder has not, directly or indirectly, submitted his or her bid price or any breakdown thereof, or the contents thereof, or divulged information or data relative thereto, or paid, and will not pay, any fee to any corporation, partnership, company, association, organization, bid depository, or to any member or agent thereof to effectuate a collusive or sham bid.

I declare, under penalty of perjury, that the foregoing is true and correct.

**Dated this _____ day of _____, 2016, at _____,
California.**

Signature of affiant: _____

NOTE: Notarization of signature required

Sample Forms

**CONTRACT AGREEMENT
CHIRIACO SUMMIT AIRPORT
COUNTY OF RIVERSIDE
RUNWAY PAVING AND GRADING**

THIS AGREEMENT, made and entered into this ____ day of _____, 2016, by and between the County of Riverside, organized and existing under and by virtue of the laws of the State of California, hereinafter designated the OWNER, and _____ of the City of _____ County of _____, State of California, hereinafter designated the CONTRACTOR.

WITNESSETH:

That the said CONTRACTOR has covenanted and agreed, for and in consideration of the payments made as provided for in the Proposal, PROJECT SPECIFICATIONS, and Contract Documents, to the CONTRACTOR by the said OWNER, and under the penalty expressed in the bond hereto attached, at his proper cost and expense, to do all the work and furnish all materials, tools, labor, and all appliance and appurtenances called for by the Agreement, free from all claims, liens, and charges whatsoever, in the manner and under the conditions hereinafter specified, that are necessary for the construction of:

The work done and materials and equipment furnished shall be strictly pursuant to and in conformity with the PLANS, PROJECT SPECIFICATIONS, and Contract Documents. The PROJECT SPECIFICATIONS and Contract Documents and DRAWINGS furnished by the CONTRACTOR with his proposal and the additional drawings or prints and other information to be furnished by the Contractor in accordance with the PROJECT SPECIFICATIONS and Contract Documents are made a part of this Agreement when and as approved by the County of Riverside, are intended to be complementary, and all PROJECT SPECIFICATIONS and Contract Documents, PLANS, DRAWINGS, or prints furnished by the Contractor and approved by the County of Riverside shall be complementary therewith. Any work appearing in or upon the one and not mentioned in the others shall be executed according to the true intent and meaning of the said PLANS, PROJECT SPECIFICATIONS, and Contract Documents, DRAWINGS, or prints the same as though the said work were contained and described in all.

The Notice Inviting Bids, Instruction to Bidders, Riverside County Provisions, General, and Special Provisions, Proposal, Bid Bond, Payment Bond, Performance Bond, Certificate of Insurance, CONTRACTOR's Affidavit, Technical Provisions, Appendix, Plans, Addenda, General Wage Decisions, any change orders issued, and any additional or supplemental specifications, notices, instructions, and drawings issued in accordance with the provisions of the Contract Documents are hereby understood to be a part of this CONTRACT. The Bid Bond is exonerated upon execution of this Agreement, the Payment Bond, Faithful Performance Bond, and the submission of proof of insurance.

It is further covenanted and agreed that the work shall be executed under the direction and supervision of the County of Riverside, California, or properly authorized agents, on whose inspection all work shall be accepted or rejected.

The COUNTY shall have full power to reject or condemn all materials furnished or work performed under this CONTRACT which do not conform to the terms and conditions herein expressed.

To prevent all disputes and litigation, it is further agreed by and between the County of Riverside, California and said CONTRACTOR, that the Aviation Division of the County of Riverside, Economic Development Agency, shall determine all questions in relation to the work and the construction thereof, and it shall in all cases decide all questions may arise relative to the execution of the work under this CONTRACT on the part of the said CONTRACTOR, and its estimates and decisions, in case any questions may arise, shall be a condition precedent to the right of said CONTRACTOR to receive any money or compensation for anything done or furnished under this CONTRACT.

Any violation or breach of the terms of this CONTRACT on the part of the CONTRACTOR / Subcontractor may result in the suspension or termination of this CONTRACT, or such other action which may be necessary to enforce the rights of the parties of this Agreement.

IN WITNESS WHEREOF, five (5) identical counterparts of this CONTRACT, each of which shall for all purposes be deemed an original thereof, have been duly executed by the parties hereinabove named, on the date and year first herein written.

SEAL (ATTEST)

COUNTY OF RIVERSIDE, CALIFORNIA
(OWNER)

Chairman, Board of Supervisors

APPROVED (AS TO FORM):

County Counsel

(CONTRACTOR)

Title: _____

WITNESSES:

Title: _____

(CORPORATE SEAL)

Address: _____

Phone: _____

Contractor's License No. _____

Classification and Expiration Date: _____

PERFORMANCE BOND

RECITALS:

1. _____, (CONTRACTOR) has entered into an Agreement dated _____ with the COUNTY OF RIVERSIDE (COUNTY) for construction of public work known as Runway Grading and Paving at Chiriaco Summit Airport for the Project.
2. _____, a _____, corporation (Surety), is the Surety under this Bond.

AGREEMENT:

We, CONTRACTOR, as Principal, and Surety, jointly and severally agree, state, and are bound unto County

1. The amount of the obligation of this Bond is one hundred percent (100%) of the estimated CONTRACT PRICE for the PROJECT of \$ _____ and inures to the benefit of COUNTY.
2. This Bond is exonerated by CONTRACTOR doing all things to be kept and performed by it in strict conformance with the Contract Documents for the PROJECT; otherwise it remains in full force and effect for the recovery of loss, damage, and expense of COUNTY resulting from failure of CONTRACTOR to so act. All of said Contract Documents are incorporated herein.
3. This obligation is binding on our successors and assigns.
4. For value received, Surety stipulates and agrees that no change, time extension, prepayment to CONTRACTOR, alteration, or addition to the terms and requirements of the Contract Documents or the work to be performed thereunder shall affect its obligations hereunder and waives notice as to such matters, except the total CONTRACT PRICE cannot be increased by more than twenty-five percent (25%) without approval of Surety.

THIS BOND is executed as of _____.

By: _____
(Authorized Signature)

Type Name _____
Its Attorney in Fact

Name of Surety

By:

Title:
"Contractor"

NOTE: This Bond must be executed by both parties with corporate seal affixed. All signatures must be acknowledged.

PAYMENT BOND

(Public Work Civil Code 3247 et seq.)

The makers of this Bond are _____, as Principal and Original CONTRACTOR, and _____, a corporation, authorized to issue Surety Bonds in California, as Surety, and this Bond is issued in conjunction with that certain public works contract dated _____, between Principal and County of Riverside, a public entity, as OWNER, for \$ _____, the total amount Payable. THE AMOUNT OF THIS BOND IS 100 PERCENT (100%) OF SAID SUM. Said CONTRACT is for public work generally consisting of Runway Paving and Grading at Chiriaco Summit Airport.

The beneficiaries of this Bond are as stated in 3248 of the Civil Code and the requirements and conditions of this Bond are as set forth in 3248, 3249, 3250, and 3252 of said Code. Without notice, Surety consents to the extension of time for performance, change in requirements, amount of compensation, or prepayment under said CONTRACT.

Dated: _____
Original Contractor

By: _____

By: _____
Its Attorney in Fact
Title: _____
(If corporation, affix seal)

STATE OF CALIFORNIA)
) ss.
COUNTY OF _____) SURETY'S
ACKNOWLEDGEMENT

On _____, before me personally appeared person whose name is subscribed the name of said corporation thereto, and acknowledged that he subscribed the name of said corporation thereto, and his name as its attorney in fact.

Notary Public (SEAL)

NOTE: All signatures must be notarized.

DIVISION II

State and Local General Provisions

DIVISION II
STATE AND LOCAL GENERAL PROVISIONS
DESCRIPTION

1.1 AUTHORITIES AND LIMITATIONS. The Riverside County Board of Supervisors alone have the power to bind the COUNTY and to exercise the rights, responsibilities, authorities, and functions vested therein by the CONTRACT Documents, except that they shall have the right to designate authorized representatives to act for them.

Neither the CONTRACT, nor any part thereof, nor moneys due or to become due there under may be assigned by the CONTRACTOR without the prior written approval of the COUNTY with the exception of the assignments to COUNTY which may be required under the terms of this CONTRACT.

1.2 LEGAL REQUIREMENTS.

- A.** CONTRACTOR shall keep informed of, and comply with, all federal, state and COUNTY laws, ordinances, rules, and regulations applicable to the Work or to those engaged or employed in the Work of this CONTRACT, especially (but not limited to) those laws relating to hours of employment, prevailing wages, payment of wages, sanitary and safety conditions for workers, workers' compensation insurance, type and kind of materials that can be used, non-discrimination in employment and affirmative action programs. Failure to identify a specific provision in these CONTRACT Documents shall not excuse the CONTRACTOR from complying with such applicable statutory requirements.
- B.** If conflict arises between provisions of the CONTRACT Documents and any such laws, rules, or regulations, the CONTRACTOR shall notify the COUNTY at once in writing. If, before receiving clarification, CONTRACTOR performs any portion of the Work affected by such apparent conflict, such performance shall be at CONTRACTOR'S own risk. CONTRACTOR shall not be entitled to any additional compensation or time by reason of the conflict or its later correction.
- C.** All work and materials shall be in full accordance with the latest applicable (or otherwise noted) codes, rules, and regulations including, but not limited to, the following:
- Uniform Building Code
 - Uniform Plumbing Code
 - Uniform Mechanical Code
 - Uniform Fire Code
 - State Fire Marshal
 - State Industrial Accident Commission's Safety Orders
 - Ordinances of the County of Riverside
 - Caltrans State Standard Specifications
 - FAA Advisory Circular Standards
- D.** Nothing in the specifications is to be construed to permit work not conforming to the above, and expense incurred complying with the above shall be borne by the CONTRACTOR. Whenever the specifications and working details require higher standards than those required by the ordinances, codes and statutes, the specifications and working details shall take priority over the ordinances, codes and statutes.

- E. In submitting a bid on this public works projects, or any subcontractor agreeing to supply goods, services, or materials, and entering a CONTRACT pursuant thereto, the CONTRACTOR and/or subcontractor do offer and agree to assign the COUNTY all rights, title, and interest in and to all causes of action it may have under Section 4 of the Clayton Act (15 U.S.C. Section 15) or under the Cartwright Act (Chapter 2 (commencing with Section 16700) of Part 2 of Division 7 of the Business and Professions Code), arising from purchases of goods, services, or materials pursuant to the public works CONTRACT or the subcontract. This assignment shall be made and become effective at the time the awarding body tenders final acknowledgement by the parties.

1.3 STANDARD REFERENCES. All documents and publications (such as, but not limited to, manuals, handbooks, codes, standards, and specifications) which are cited in this CONTRACT for the purpose of establishing technical (non-administrative) requirements applicable to equipment, materials, or workmanship under this CONTRACT, shall be deemed to be incorporated herein as though fully set forth.

Whenever reference is made to any particular document or publication, the CONTRACTOR shall comply with the requirements set out in the edition specified in this CONTRACT, or if not specified, the latest edition or revision thereof, in effect on the date of the solicitation of bid on this project, except as modified by, as otherwise provided in, or as limited to type, class, or grade, in the specifications of this CONTRACT.

1.4 PERMITS, LICENSES, FEES AND TAXES.

A. County's Responsibilities.

1. The COUNTY will apply for all plan checks and will apply for and obtain the Building Permit(s), the Grading Permit and Construction Permits required by the COUNTY, paying all fees in connection therewith.
2. The COUNTY will furnish, at no expense to the CONTRACTOR, all on-site inspection of the Work and will arrange and pay for off-site inspection only as noted in the CONTRACT DOCUMENTS.

B. Contractor's Responsibilities.

1. The CONTRACTOR shall obtain and pay for all other permits and licenses required for the Work, including excavation permit and for plumbing, mechanical and electrical work and for operations in or over public streets or right of way under jurisdiction of public agencies other than the COUNTY.
2. Exclusive of off-site inspection specified herein to be the COUNTY'S responsibility, the CONTRACTOR shall arrange and pay for all off-site inspection of the Work, including certification, required by the specifications, drawings, or by governing authorities.
3. Before Acceptance of the project by the COUNTY, the CONTRACTOR shall submit all licenses, permits, and certificates of inspection to the COUNTY.

1.5 SEPARATE CONTRACTS.

- A. The COUNTY reserves the right to perform work related to this project with its own forces, and to award separate CONTRACTs in connection with other portions of the project or other work on the site. The CONTRACTOR shall cooperate with others in the prosecution of all work and shall not interfere with material, appliances or workmen of the COUNTY or any other CONTRACTOR engaged by the COUNTY at the site of the Work. In case of disagreement regarding such use, the matter shall be referred to the COUNTY whose decision relative to said use shall govern.

- B. The CONTRACTOR shall afford the COUNTY and separate CONTRACTORS reasonable opportunity for the introduction and storage of their materials and equipment and the execution of their work, and shall properly connect and coordinate CONTRACTOR'S Work with theirs.
- C. If any part of the CONTRACTOR'S Work depends for proper execution or results upon the work of the COUNTY or any separate CONTRACTOR, the CONTRACTOR shall inspect and promptly report to the COUNTY any discrepancies or defects in such other work that render it unsuitable for such proper execution and results. Failure of the CONTRACTOR to so inspect and report shall constitute an acceptance of the COUNTY'S or the separate CONTRACTOR'S work as fit and proper to receive the Work, except as to defects which may develop in the other separate CONTRACTOR'S work after the execution of the CONTRACTOR'S Work.
- D. Should the CONTRACTOR cause damage to the work or property of any separate CONTRACTOR on the Project, the CONTRACTOR shall, upon due notice, settle with such other CONTRACTOR by agreement, if both will so settle. If such separate CONTRACTOR sues the COUNTY because of any damage alleged to have been so sustained, the CONTRACTOR agrees to indemnify and defend the COUNTY in such proceedings with the COUNTY retaining the right to select and hire independent counsel for the COUNTY paid by the CONTRACTOR.
- E. Any cost caused by defective or ill-timed work shall be borne by the party responsible therefore.

1.6 COUNTY'S AUTHORIZED REPRESENTATIVE, INSPECTOR(S), AND ENGINEER.

- A. **Authorized Representative.** The COUNTY shall designate a representative during the Work, who shall have the right to be present at the job site during construction and shall supervise any additional representatives appointed by the COUNTY.
- B. **Inspector(s).** The Inspector(s) shall have the right to observe the installation of all materials and equipment to be incorporated into the Work and the placing of such material and equipment to determine in general if the Work is proceeding in accordance with the CONTRACT DOCUMENTS. The Inspector(s) is not authorized to make changes in the CONTRACT DOCUMENTS. On the basis of his observations, he shall keep the COUNTY informed as to the progress of the Work. The Inspector shall not be responsible for means, methods, techniques, sequences, or procedures of construction nor for safety precautions and programs in connection with the Work. Nor will the Inspector be responsible for the CONTRACTOR'S failure to carry out the Work in accordance with the CONTRACT DOCUMENTS.
- C. **ENGINEER.** The COUNTY has retained an ENGINEER for this project. The ENGINEER will advise and consult with the COUNTY, and the COUNTY will issue instructions to the CONTRACTOR. The ENGINEER will be requested to interpret the requirements of the CONTRACT. When requested by the COUNTY, the ENGINEER will, within a reasonable time, render such interpretations as he may deem necessary for the proper execution of the Work.

The ENGINEER will make periodic visits to the job site to familiarize himself generally with the progress and quality of the Work and to determine in general whether the work is proceeding in accordance with the CONTRACT Documents. Based on such observations he will recommend approval of applications for progress payments made by CONTRACTOR. The ENGINEER shall not be responsible for means, methods, techniques, sequences, or procedures of construction nor for safety precautions and programs in connection with the Work. Nor will the ENGINEER be responsible for the CONTRACTOR'S failure to carry out the Work in accordance with the Contract Documents.

2.1 BONDS AND INSURANCE

A. Bids of \$25,000 or Less. If the total amount bid on the Work is \$25,000 or less, the payment bond and performance bond are not required, provided that one payment of all compensation shall be made following Acceptance of all work.

B. Bonds.

1. General Requirements

a. Before commencing any Work under this CONTRACT, the CONTRACTOR shall file four of each bond with the COUNTY. These bonds shall be in the amounts and for the purposes specified below. They shall be surety bonds issued by:

1) Either a California Admitted Surety OR a current Treasury Listed Surety (Federal Register).

And

2) Either a current A.M. Best A VIII rated Surety OR an admitted surety insurer which complies with the provisions of the Code of Civil Procedure, § 995.660.

b. Should any surety or sureties upon said bonds or any of them become insufficient, CONTRACTOR shall renew said bond or bonds with good and sufficient sureties within ten (10) calendar days after receiving notice from the COUNTY that the surety or sureties are insufficient. Cost of bonds shall be included in the bid price.

2. **Performance Bond.** The successful bidder shall deliver to the COUNTY an executed Performance Bond on the attached form in an amount equal to 100% of the accepted bid as security for the faithful performance of the CONTRACT.

3. **Payment Bond.** The successful bidder shall deliver to the COUNTY an executed Payment Bond on the attached form in an amount equal to 100% of the accepted bid as security for the payment of all persons performing labor and furnishing materials in connection with the Work.

C. Insurance.

1. **General Requirements.** Before commencing this Work under the CONTRACT, and without limiting or diminishing CONTRACTOR'S obligation to indemnify and hold the COUNTY harmless, the CONTRACTOR shall procure and maintain, or cause to be maintained at its sole cost and expense, the following insurance coverages during the term of this CONTRACT.

The successful bidder must submit:

a. Copy of its commercial general liability policy and its excess policy or binder until such time as a policy is available, including the declarations page, applicable endorsements, riders, and other modifications in effect at the time of CONTRACT execution. Standard ISO form no. CG 0001 or similar exclusions are allowed if not inconsistent with other sections.

b. Certificate of insurance showing all other required coverages. Certificates of insurance, as evidence of required insurance for the auto liability and any other required policy, shall set forth deductible amounts applicable to each policy and all exclusions that are added by endorsement to each policy. The evidence of insurance shall provide that no cancellation, lapse, or reduction of coverage will occur without 30 days prior written notice to the COUNTY.

- c. A declaration under the penalty of perjury by a CPA certifying the accountant has applied GAAP guidelines confirming the successful bidder has sufficient funds and resources to cover any self-insured retentions if the self-insured retention is over \$50,000.

If the successful bidder uses any form of self-insurance for workers compensation in lieu of an insurance policy, it shall submit a certificate of consent to self-insure under Labor Code 3700.

2. **Workers' Compensation Insurance.** CONTRACTOR shall secure Workers' Compensation Insurance (Coverage A) as prescribed by the laws of the State of California. Policy shall include Employers' Liability (Coverage B) including Occupational Disease with limits not less than \$1,000,000 per person per accident. Policy shall be endorsed, if applicable, to provide a Borrowed Servant/Alternate Employer Endorsement, and contain a Waiver of Subrogation in favor of the County of Riverside, pursuant to Section 3700 of the Labor Code of the State of California, CONTRACTOR shall file with the COUNTY before commencing the Work the following signed certification:

"I am aware of the provisions of Section 3700 of the Labor Code, which requires every employer to be insured against liability for workers' compensation or to undertake self-insurance in accordance with the provisions of that Code, and I shall comply with such provisions before commencing the performance of the Work of this CONTRACT."

3. **Commercial General Liability.** Commercial General Liability insurance coverage, including but not limited to, premises liability, contractual liability, products/completed operations if applicable, personal and advertising injury – which may arise from or out of CONTRACTOR'S operations, use, and management of the premises, or the performance of its obligations hereunder. Policy shall name the COUNTY, their Directors, Officers, special Districts, Board of Supervisors, employees, agents or representatives as Additional Insured, and contain a Waiver of Subrogation in favor of the County of Riverside. Policy limits shall not be less than \$1,000,000 per occurrence combined single limits. If such insurance contains a general aggregate limit, it shall apply separately to this agreement or be no less than two (2) times the occurrence limit. Policy shall also contain coverage for \$5,000 Medical Payments coverage per accident, per person, and Fire Legal Liability in an amount not less than \$50,000.
4. **Vehicle Liability.** If CONTRACTOR'S vehicles or licensed mobile equipment are used on COUNTY property, or used in any manner on behalf of the COUNTY, CONTRACTOR shall maintain auto liability insurance for all owned, non-owned and hired automobiles in an amount not less than \$1,000,000 per occurrence combined single limit, \$2,000,000 in the aggregate. Policy shall name the County of Riverside, their Director's Officers, Special Districts, Board of Supervisors, employees, agents, or representatives as Additional Insured, and provide a Waiver of Subrogation in favor of the County of Riverside.
5. **Property (Physical Damage).** All-Risk property insurance coverage for the full replacement value of all CONTRACTOR'S equipment, improvements/alterations, temporary structures, and systems (Care, Custody, and Control of Contractor) used on COUNTY property, or used in any way connected with the accomplishment of the Work performed in this contract.
6. **Course of Construction Insurance.** CONTRACTOR shall provide All Risk Builder's Risk (Course of Construction) insurance, including earthquake and flood if in an earthquake or flood zone (required on financed or bond financing arrangements), covering the COUNTY and the CONTRACTOR and every subcontractor of every tier for the entire project including property to be used in the construction of the project while such property is at off site storage locations or while in transit. Policy shall include coverage for collapse, faulty workmanship, debris removal, expediting expense, Fire Department

Service charges, valuable papers and records, trees, grass, shrubbery and plants. If scaffolding, falsework and temporary buildings are insured separately by the CONTRACTOR or others, evidence of such separate coverage shall be provided to COUNTY prior to the start of the work. Policy shall be written on a completed value form. Policy shall also provide coverage for temporary structures (onsite offices, etc.), fixtures, machinery and equipment being installed as part of the construction project. (The Base Bid including course of construction insurance shall be used for determination of lowest bid, unless otherwise stated in the bid form.).

CONTRACTOR shall provide a bid price with Course of Construction insurance as outlined herein, and shall also separately provide the cost of the Course of Construction insurance and deductible; and shall declare all terms, conditions, coverages and limits upon request of COUNTY. COUNTY RETAINS THE RIGHT TO CHOOSE TO USE ITS OWN COURSE OF CONSTRUCTION PROGRAM. If the COUNTY program is chosen, CONTRACTOR shall assume the cost of any and all applicable policy deductibles (currently \$50,000 per occurrence), and shall insure its own machinery, equipment, tools, etc., from any loss of any nature whatever. If COUNTY elects the CONTRACTOR'S All Risk Builder's Risk Program, CONTRACTOR shall be responsible for any and all policy deductibles.

7. General Insurance Provisions.

- a. Any insurance carrier providing insurance coverage hereunder shall be admitted to the State of California unless waived, in writing, by the County Risk Manager. Carrier(s) shall have an A.M. BEST rating of not less than an A: VIII. Insurance deductibles or self-insured retentions must be declared by the carrier(s), and such deductibles and retentions shall have the prior written consent from the County Risk Manager. At the election of the Risk Manager, carriers shall provide written notification, and shall either 1) reduce or eliminate such deductibles or self-insured retentions, or 2) procure a bond which guarantees payment of losses and related investigations, claims administration, and defense costs and expenses. If no written notice is received from the County Risk Manager within ten (10) days of the acceptance of agreement, then such deductibles or self-insured retentions shall be deemed acceptable.
- b. Cause its insurance carrier(s) to furnish the County of Riverside with either 1) a properly executed original Certificate(s) of Insurance and certified original copies of Endorsements effecting coverage as required herein, or 2) if requested to do so in writing by the County Risk Manager, provide original Certified copies of policies including all Endorsements and all attachments thereto, showing such insurance is in full force and effect. The County of Riverside, their Directors and Officers, Special Districts, Board of Supervisors, elected officials, employees, agents or representatives are named as Additional Insureds. Further, said Certificate(s) and policies of insurance shall contain the covenant of the insurance carrier(s) that shall provide no less than thirty (30) days written notice be given to the County of Riverside prior to any material modification or cancellation of such insurance. In the event of a material modification or cancellation of coverage, this Agreement shall terminate forthwith, unless the County of Riverside receives, prior to such effective date, another properly executed original Certificate of Insurance and original copies of endorsements or certified original policies, including all endorsements and attachments thereto evidencing coverages set forth herein and the insurance required herein is in full force and effect. **CONTRACTOR shall not commence operations under this Agreement until the County of Riverside has been furnished original Certificate(s) of Insurance and certified original copies of Endorsements or policies of insurance including all Endorsements and any and all other attachments as required in this Section. The**

original Endorsements for each policy and the Certificate of Insurance shall be signed by an individual authorized by the insurance carrier to do so on its behalf.

- c. It is understood and agreed to by the parties hereto and the insurance company(s), that the Certificate(s) of Insurance and policies shall so covenant and shall be construed as primary, and the COUNTY'S insurance and or deductibles and or self-insured retentions or self-insured programs shall not be construed as contributory.
- d. CONTRACTOR shall pass down the insurance obligations contained herein to all tiers of sub-consultants working under this Agreement.

Bond & insurance information to be included with next submittal.

3.1 SITE CONDITIONS

A. Differing Site Conditions.

- 1. The CONTRACTOR shall have reviewed and ascertained pertinent local conditions such as location, accessibility, and general character of the site and satisfy himself as to the conditions under which the Work is to be performed. No claim for allowances shall be made because of CONTRACTOR'S error or negligence in acquainting himself with the conditions at the site.
- 2. The CONTRACTOR shall carefully study and compare the Contract Documents with each other and with information furnished by COUNTY. The CONTRACTOR shall promptly report in writing to COUNTY any errors, inconsistencies, or omissions in the Contract Documents or inconsistencies with applicable code requirements observed by CONTRACTOR.
- 3. If CONTRACTOR performs any construction activity which it knows or should know involves an error, inconsistency, or omission without notifying and obtaining the written consent of COUNTY, CONTRACTOR shall be responsible for the resultant losses, including, without limitation, the costs of correcting defective work.
- 4. The COUNTY will furnish surveys necessary to properly locate the property and establish the boundaries thereof with general reference points as well as to enable the CONTRACTOR to proceed with the Work.
- 5. The CONTRACTOR shall provide competent engineering services to lay out the Work and all parts thereof and to establish all grades and elevations in accordance with the CONTRACT requirements. The CONTRACTOR shall verify the figures shown on the survey and approach drawings before undertaking any construction work and shall be responsible for the accuracy of the finished work.
- 6. The CONTRACTOR shall protect and preserve established bench marks and monuments and shall make no changes in locations without the written approval of the COUNTY. Any bench marks or monuments that are lost or destroyed shall be replaced by the CONTRACTOR subsequent to notification and approval from COUNTY.

B. Site Investigation and Conditions Affecting the Work.

- 1. The CONTRACTOR acknowledges by submission of his/her bid that he is satisfied as to the character, quality, and quantity of surface and subsurface materials or obstacles to be encountered insofar as this information is reasonably ascertainable from an inspection of the site, including any exploratory work deemed necessary by the CONTRACTOR. Any failure of the CONTRACTOR to take the actions described and acknowledged in this paragraph will not relieve the CONTRACTOR

from responsibility for estimating the difficulty and cost of successfully performing the Work, or for proceeding to successfully perform the Work without additional expense to the COUNTY.

2. Elsewhere in the Contract Documents reference may be made, graphically, descriptively or both, to the existence or possible existence of other improvements affecting the site and the prosecution of the work such as surface and subsurface utilities, drainage ditches and courses, buildings, fencing, retaining walls, roadways, curbs, trees, shrubs, and similar matters. Such matters are included to be used by CONTRACTOR to the extent he deems appropriate. However, it is expressly understood and agreed:
 - a. Showing or describing such items does not mean that it is an exhaustive and complete presentation and that as to matters shown or described that they necessarily exist.
 - b. All graphic presentations are schematic only unless the contrary is clearly set out elsewhere as to a particular matter.
 - c. Whenever in the plans survey markers are shown, boundaries of the site are shown or contour lines are shown, CONTRACTOR may assume that such matters are shown in accordance with acceptable standards. All improvements of the nature above described, whether elsewhere shown or described or not, shall, unless the contrary is elsewhere specifically directed, remain in place, undisturbed and suitably protected during the course of the work.
 - d. Whenever during the course of the work a subsurface improvement is discovered which CONTRACTOR believes is unknown to COUNTY, he shall immediately so inform the Consultant and COUNTY. Except as elsewhere provided, whenever in the course of the work it becomes apparent that the work cannot proceed without the destruction or relocation of any improvement, whether shown or described or not, CONTRACTOR shall immediately cease work affecting such improvements and notify the Consultant and COUNTY as to such circumstance and await instructions as to how to proceed.
 - e. All dimensions shown for existing conditions and all dimensions required for work that is to connect with work now in place, shall be verified and calculated by the CONTRACTOR by actual measurement of the existing work. Any discrepancies between the Contract Documents and the existing conditions shall be referred to the authorized representative of the COUNTY before any work affected thereby has been performed. Failure to notify the COUNTY before starting work will be considered acceptance by the CONTRACTOR. Where doubts as to dimensions exist, COUNTY shall determine the correct dimensions.
 - f. The CONTRACTOR shall be required to cooperate fully with all utility forces or forces of other public agencies engaged in relocation, lowering, altering or otherwise rearranging any facilities interfering with the progress of work or installing any facilities thereon.

The CONTRACTOR will also be required to cooperate fully with any COUNTY or State forces working on or near the project, or requiring access to the work in the performance of their duties.

- C. Dimensions and Measurements.** All dimensions shown for existing conditions and all dimensions required for work that is to connect with work now in place, shall be verified and calculated by the CONTRACTOR by actual measurement of the existing work. Any discrepancies between the Contract Documents and the existing conditions shall be referred to the authorized representative of the COUNTY before any work affected thereby has been performed. Failure to notify the COUNTY before starting work

will be considered acceptance by the CONTRACTOR. Where doubts as to dimensions exist, COUNTY shall determine the correct dimensions.

4.1 SPECIFICATIONS AND DRAWINGS.

A. Standard Specifications. The Standard Specifications referenced in this document are contained in the most recent edition of the *Standard Specifications for Public Works Construction*, including all supplements as written and promulgated by the Joint Cooperative Committee of the Southern California Chapter of the American Public Works Association and the Southern California District of the Associated General Contractors of California. Copies of those Standard Specifications are available from the publisher:

Building News, Inc.
3055 Overland Avenue
Los Angeles, CA 90034
(213) 202-7775

The Standard Specifications set forth above will control this CONTRACT except as amended by the Plans, and Specification contained Contract Documents and as listed below.

1. The 2010 *Standard Specifications, Department of Transportation, State of California*, will control the installation of traffic signals, signs, striping, construction materials, and construction methods for this CONTRACT, except as amended by the Plans, General Provisions, or other Contract Documents. Only those sections requiring amendment or elaboration or specifying options are called out.
2. The Federal Aviation Administration Advisory Circular 150-5370-10G will control the work items described in Division IV, Technical Specifications except as amended by the Plans or other Contract Documents. Only those sections requiring amendment or elaboration or specifying options are called out.

B. Subdivisions. For convenience, the specifications are arranged into several sections, but such separation shall not be considered as the limits of the work required of any separate trade. The terms and conditions of such limitations are wholly between the CONTRACTOR and his subcontractors. Requirements contained in any section are required as if contained in all sections and are the responsibility of the CONTRACTOR. The CONTRACTOR, prior to awarding subcontracts, will assure the Work required as a whole has been coordinated among the subcontracts.

C. Record Documents.

1. The CONTRACTOR shall keep on the work site a copy of the awarded construction documents (drawings and specifications) and shall at all times give the COUNTY and ENGINEER access thereto.
2. The CONTRACTOR will be given one set of drawings and specifications which shall be kept at the site of the Work at all times and updated weekly. Payment may be withheld if drawings are not kept current. Exact locations of all pipes and conduits and all changes in construction and details shall be indicated and dimensions provided upon these drawings, and all changes in materials and equipment installed shall be indicated in these specifications. Upon completion and prior to Acceptance of the Work, a final reproducible (transparencies) set of project record documents and specifications shall be submitted to the COUNTY by the CONTRACTOR.

3. The working details will indicate dimensions, position, and kind of construction, and the specifications, qualities, and methods. Any Work indicated on the working details and not mentioned in the specifications, or vice versa, shall be furnished as though fully set forth in both. Work not particularly detailed, marked, or specified shall be the same as similar work that is detailed, marked, or specified.
4. In case of discrepancy in the documents, the matter shall be promptly submitted to the COUNTY, who shall make a determination in writing. Any adjustment by the CONTRACTOR without such a determination shall be at his own risk and expense. The COUNTY shall furnish from time to time such detailed information as considered necessary to clarify the Work.
5. Where the word "similar" occurs on the drawings, it shall have a general meaning and not be interpreted as meaning identical, and all details shall be worked out in relation to their location and their connection with other parts of the work.
6. Standard details or specification drawings are applicable when listed, bound with specifications, noted on the drawings or referenced elsewhere in the specifications. Where the notes on the drawings indicate modifications, such modifications shall govern.
7. All drawings, specifications and copies thereof furnished to the CONTRACTOR are the property of the COUNTY and shall not be used on other work without its consent. Upon completion of this project, all copies of the drawings and specifications shall be returned to the COUNTY.

5.1 CLARIFICATIONS/REQUEST FOR INFORMATION AND ADDITIONAL INSTRUCTIONS.

A. Notification by CONTRACTOR.

1. Should CONTRACTOR discover what he perceives to be conflicts, omissions, or errors in the Contract Documents, or have any question concerning interpretation or clarification of the Contract Documents, or if it appears that the work to be done or any matters relative thereto are not sufficiently detailed or explained in the Contract Documents, then, before proceeding with the work affected, CONTRACTOR shall notify COUNTY'S authorized representative in writing, and request interpretation, clarification, or additional detailed information concerning the work. The CONTRACTOR shall ask for the clarification (Request for Information) immediately upon discovery but no less than 14 calendar days prior to the start date of the activities related to the clarification, based on the latest updated version of the accepted Progress Schedule. COUNTY, whose decision shall be final and conclusive, shall resolve such questions and issue instructions to CONTRACTOR. Should CONTRACTOR proceed with work affected before receipt of instructions from COUNTY, CONTRACTOR shall remove and replace or adjust work which is not in accordance with the instructions from COUNTY and shall be responsible for resultant damage, defect or added cost. In event of failure to agree as to scope of CONTRACT requirements, CONTRACTOR shall follow the procedure set forth in the DISPUTES article.
2. The CONTRACTOR shall not be entitled to any compensation for delays, disruptions, inefficiencies or additional administrative effort caused by the CONTRACTOR'S untimely review of the CONTRACT DOCUMENTS for potential conflicts, omissions, discrepancies or ambiguities.
3. COUNTY may charge back to the CONTRACTOR, time and expenses associated with RFI's, as may be reasonably determined by the COUNTY to be unnecessary.

B. Additional Detailed Instructions.

1. The COUNTY may furnish additional detailed written instructions on any Request for Information to further explain the Work. If in the opinion of CONTRACTOR, the additional detailed instructions constitute work in excess of the scope of the CONTRACT, he must submit written notice thereof immediately to the COUNTY, but no later than seven (7) calendar days following receipt of such instruction(s), and in any event prior to commencement of work thereon. The CONTRACTOR shall not be entitled to additional compensation due to any additional instructions unless the CONTRACTOR shall have given the appropriate written notice. COUNTY will then consider such notice and, if in its judgment it is justified, the COUNTY instructions will be revised or extra work shall be authorized by Change Order. In the event of a dispute hereunder, attention is directed to the DISPUTES article.

6.1 QUALIFICATIONS FOR EMPLOYMENT AND APPRENTICESHIP STANDARDS. In accordance with Section 1735 of the *California Labor Code*, no person under the age of 16 years and no person currently serving sentence in a penal or correctional institution shall be employed to perform any Work under this CONTRACT. No person whose age or physical condition is such as to make his employment dangerous to his health or safety or to the health or safety of others shall be employed to perform Work under this CONTRACT; provided that this requirement shall not operate against any physically handicapped persons otherwise employable where such persons may be safely assigned to Work which they ably perform.

This CONTRACT is subject to the provisions of Sections 1777.5 and 1777.6 of the *California Labor Code* concerning the employment of apprentices by the CONTRACTOR or any subcontractor under him. Section 1777.5 as amended, requires the CONTRACTOR or subcontractor employing tradesmen in any apprenticeable occupation to apply to the Joint Apprenticeship Committee nearest the site of this project and which administers the apprenticeship program in that trade for a certificate of approval. The certificate will also fix the ratio of apprentices to journeymen that will be used in the performance of the CONTRACT.

The CONTRACTOR is required to make contributions to funds established for the administration of apprenticeship programs if he employs registered apprentices or journeymen in any apprenticeable trade on such CONTRACTS and if other CONTRACTORS on the public works site are making contributions.

All employees engaged in work on the project under this CONTRACT shall have the right to organize and bargain collectively through representatives of their own choosing, and such employees shall be free from interference, restraint, and coercion of employers in the designation of such employees for the purpose of collective bargaining or other mutual aid or protection, and no person seeking employment under this CONTRACT shall be required as a condition of initial or continued employment to join any company, union, or to refrain from joining, organizing, or assisting a labor organization of such person's own choosing. No person in the employment of the COUNTY shall be employed by this CONTRACTOR.

6.2 WAGES AND RECORDS.

A. Wage Rates.

1. Pursuant to Section 1770 and 1773 et seq. of the *California Labor Code*, the Director of Industrial Relations has ascertained the general prevailing rate of per diem wages and the rates for overtime and holiday work in the locality in which the work is to be performed for each craft, classification, or type of workman needed to execute the CONTRACT which will be awarded to the successful bidder, copies

of which are on file and available upon request at the Clerk of the Board, Board of Supervisors, 4080 Lemon St., 14th Floor, Riverside, CA 92501-3655, and shall be posted at the job site.

2. It shall be mandatory upon the CONTRACTOR and upon any subcontractor under him, to pay not less than the said specified rates to all laborers, workmen, and mechanics employed in the execution of the CONTRACT. It is further expressly stipulated that the CONTRACTOR shall, as a penalty to COUNTY, forfeit twenty-five dollars (\$25.00) for each calendar day, or portion thereof, for each laborer, workman, or mechanic paid less than the stipulated prevailing rates for any work done under this CONTRACT by him or by any subcontractor under him; and CONTRACTOR agrees to comply with all provisions of Section 1770 et. seq. of the *California Labor Code*.
3. In case it becomes necessary for the CONTRACTOR or any sub-CONTRACTOR to employ on the project under this CONTRACT any person in a trade or occupation (except executives, supervisory, administrative, clerical, or other non-manual workers as such) for which no minimum wage rate is herein specified, the CONTRACTOR shall immediately notify the COUNTY who will promptly thereafter determine the prevailing rate for such additional trade or occupation and shall furnish the CONTRACTOR with the minimum rate based thereon. The minimum rate thus furnished shall be applicable as a minimum for such trade or occupation from the time of the initial employment of the person affected and during the continuance of such employment.
4. The COUNTY will not recognize any claim for additional compensation because of the payment by the CONTRACTOR of any wage rate in excess of the prevailing wage rate set forth as provided herein. The possibility of wage increases is one of the elements to be considered by the CONTRACTOR in determining his bid, and will not under any circumstances be considered as the basis of a claim against the COUNTY on the CONTRACT.

B. Wage Records.

1. The CONTRACTOR and each subcontractor shall keep or cause to be kept an accurate record (certified payroll) showing the names and occupations of all laborers, workers, and mechanics employed by him in connection with the execution of this CONTRACT or any subcontract thereunder. The record shall show the actual per diem wages paid to each of said workers, which records shall be provided to the COUNTY, and to the Division of Labor Standards Enforcement upon its request. Copies provided will include one which has the name and social security numbers marked out.

6.3 NOTICE OF LABOR DISPUTES. If the CONTRACTOR has knowledge that any actual or potential labor dispute is delaying or threatens to delay the timely performance of this CONTRACT, the CONTRACTOR shall immediately give notice, including all relevant information, to the COUNTY.

The CONTRACTOR agrees to insert the substance of this clause, including this paragraph into any subcontract in which a labor dispute may delay the timely performance of this CONTRACT; except that each subcontract shall provide that in the event its timely performance is delayed or threatened by delay by any actual or potential labor dispute, the subcontractor shall immediately notify the next higher tier subcontractor or the prime CONTRACTOR, as the case may be, of all relevant information concerning the dispute.

6.4 NONDISCRIMINATION.

A. Equal Employment Opportunity.

1. CONTRACTOR agrees for the duration of this CONTRACT that it will not discriminate against any employee or applicant for employment because of race, color, religion, sex, national origin, age,

political affiliation, marital status, or handicap. The CONTRACTOR will take affirmative action to insure that employees are treated during employment or training without regard to their race, color, religion, sex, national origin, age, political affiliation, marital status, or handicap. Such action shall include, but not be limited to, the following: employment, upgrading, demotion, or transfer; recruitment or recruitment advertising; layoff or termination; rates of pay or other forms of compensation; and selection for training, including apprenticeship. The CONTRACTOR agrees to post in conspicuous places, available to employees and applicants for employment, notices to be provided setting forth the provisions of this nondiscrimination clause.

2. The CONTRACTOR will in all solicitations or advertisements for employees placed by or on behalf of the CONTRACTOR, state that all qualified applicants will receive consideration for employment without regard to race, color, religion, sex, national origin, age, political affiliation, marital status, or handicap.
3. The CONTRACTOR will send to each labor union or other representative of workers with which it has a collective bargaining agreement or other CONTRACT or understanding, a notice advising the workers' representative of the CONTRACTOR commitments under this agreement.
4. The CONTRACTOR agrees that it will comply with the provisions of *Titles VI and VII of the Civil Rights Act, Revenue Sharing Act Title 31*, U.S. Code Section 2716, and California Government Code Section 12990.
5. The CONTRACTOR agrees that it will assist and cooperate with the COUNTY, the State of California and the United States Government in obtaining compliance with the equal opportunity clause, rules, regulations, and relevant orders of the State of California and United States Government issued pursuant to the Acts.
6. In the event of the CONTRACTOR'S non-compliance with the discrimination clause, the affirmative action plan of this CONTRACT, or with any of the said rules, regulations or orders, this CONTRACT may be canceled, terminated, or suspended in whole or in part by the COUNTY.

B. Handicapped Non-discrimination. This project is subject to Section 504 of the *Rehabilitation Act of 1973* as amended, (29 U.S.C. 794), and the *Americans with Disabilities Act* of 1990, as amended, and all requirements imposed by the guidelines and interpretations issued thereto. In this regard, the COUNTY and all of its contractors and subcontractors will take all reasonable steps to ensure that handicapped individuals have the maximum opportunity for the same level of aid, benefit or service as any other individual.

C. Fair Employment and Housing Act Addendum. In the performance of this CONTRACT, the CONTRACTOR will not discriminate against any employee or applicant for employment because of race, sex, color, religion, ancestry, or national origin. The CONTRACTOR will take affirmative action to ensure that applicants are employed, and that employees are treated during employment, without regard to their race, sex, color, religion, ancestry, or national origin. Such action shall include, but not limited to, the following: employment, upgrading, emotion, or transfer; recruitment or recruitment advertising; layoff or termination; rates of pay or other forms of compensation; and selection for training, including apprenticeship. The CONTRACTOR shall post in conspicuous places, available to employees and applicants for employment, notices to be provided by the State, or COUNTY setting forth the provisions of this Fair Employment and Housing Section.

- D. **Access to Records.** The CONTRACTOR will permit access to his records of employment, employment advertisements, application forms, and other pertinent data and records by the State Fair Employment and Housing Commission, or any other COUNTY of the State of California designated by the awarding authority, for the purposes of investigation to ascertain compliance with the Fair Employment and Housing section of this CONTRACT.
- E. **Remedies for Willful Violation.** The State or local COUNTY may determine a willful violation of the Fair Employment and Housing provision to have occurred upon receipt of a final judgment having that effect from a court in an action to which CONTRACTOR was a party, or upon receipt of a written notice from the Fair Employment and Housing Commission that it has investigated and determined that the CONTRACTOR has violated the Fair Employment and Housing Act and has issued an order or obtained an injunction under Government Code Sections 12900, et seq.

7.1 FAIR EMPLOYMENT PRACTICES. In connection with the performance of work under this CONTRACT, the CONTRACTOR agrees as follows:

- A. The CONTRACTOR will not willfully discriminate against any employee or applicant for employment because of race, sex, color, religion, ancestry, or national origin. The CONTRACTOR will take affirmative action to ensure that applicants are employed, and that employees are treated during employment, without regard to their race, sex, color, religion, ancestry, or national original. Such action shall include, but not be limited to, the following: employment, upgrading, demotion or transfer; recruitment or recruitment advertising; layoff or termination; rates of pay or other forms of compensation; and selection for training, including apprenticeship. The CONTRACTOR agrees to post in conspicuous places, available to employees and applicants for employment, notices to be provided by the awarding authority setting forth the provisions of this Fair Employment Practices section.
- B. The CONTRACTOR will send to each labor union or representative of workers with which he has a collective bargaining agreement or other CONTRACT or understanding, a notice, to be provided by the awarding authority, advising the said labor union or workers' representative of the CONTRACTOR'S commitments under this section, and shall post copies of the notice in conspicuous places available to employees and applicants for employment.
- C. The CONTRACTOR will permit access to his records of employment, employment advertisements, application forms, and other pertinent data and records by the Fair Employment Practices Commission, the awarding authority or any other appropriate COUNTY of the State of California designated by the awarding authority, for the purposes of investigation to ascertain compliance with the Fair Employment Practices section of this CONTRACT.
- D. A finding of willful violation of the Fair Employment Practices section of this CONTRACT or of the Fair Employment Practices Act shall be regarded by the awarding authority as a basis for determining the CONTRACTOR to be not a "responsible bidder" as to future CONTRACTS for which such CONTRACTOR may submit bids, for revoking the CONTRACTOR'S prequalification rating, if any, and for refusing to establish, reestablish or renew a prequalification rating for the CONTRACTOR.

The awarding authority shall deem a finding of willful violation of the Fair Employment Practices Act to have occurred upon receipt of written notice from the Fair Employment Practices Commission that it has investigated and determined that the CONTRACTOR has violated the Fair Employment Practices

Act and has issued an order under Labor Code Section 1426 or obtained an injunction under Labor Code Section 1429.

Upon receipt of such written notice from the Fair Employment Practices Commission, the awarding authority shall notify the CONTRACTOR that unless he demonstrates to the satisfaction of the awarding authority within a stated period that the violation has been corrected, his prequalification rating will be revoked at the expiration of such period.

- E.** The CONTRACTOR agrees, that should the awarding authority determine that the CONTRACTOR has not complied with the Fair Employment Practices section of this CONTRACT, then pursuant to Labor Code Sections 1735 and 1775, the CONTRACTOR shall, as a penalty to the awarding authority, forfeit, for each calendar day, or portion thereof, for each person who was denied employment as a result of such noncompliance, the penalties provided in the Labor Code for violation of prevailing wage rates. Such monies may be recovered from the CONTRACTOR. The awarding authority may deduct any such damages from any monies due the CONTRACTOR from the Chiriaco Summit project.
1. Nothing contained in this Fair Employment Practices section shall be construed in any manner or fashion so as to prevent the awarding authority of the Chiriaco Summit project from pursuing any other remedies that may be available at law.
 2. Nothing contained in this Fair Employment Practices section shall be construed in any manner or fashion so as to require or permit the hiring of an employee not permitted by the National Labor Relations Act.
- F.** Prior to award of the CONTRACT, the CONTRACTOR shall certify to the awarding authority that he has or will meet the following standards for affirmative compliance, which shall be evaluated in each case by the awarding authority:
1. The CONTRACTOR shall provide evidence, as required by the awarding authority, that he has notified all supervisors, foremen and other personnel offices in writing of the content of the anti-discriminating clause and their responsibilities under it.
 2. The CONTRACTOR shall provide evidence, as required by the awarding authority, that he has notified all sources of employee referrals (including unions, employment agencies, advertisements, Department of Employment) of the content of the anti-discrimination clause.
 3. Personally, or through his representatives, the CONTRACTOR shall, through negotiations with the unions with whom he has agreements, attempt to develop an agreement which will:
 - a. Spell out responsibilities for nondiscrimination in hiring, re-referral, upgrading and training.
 - b. Otherwise implement an affirmative anti-discrimination program in terms of the unions' specific areas of skill and geography, to the end that qualified minority workers will be available and given an equal opportunity for employment.
 4. The CONTRACTOR shall notify the contracting COUNTY of opposition to the anti-discrimination clause by individuals, firms or organizations during the period of its prequalification.
- G.** The CONTRACTOR will include the provisions of the foregoing Paragraphs A through E in every first tier subcontract, so that such provisions will be binding upon each such subcontractor.

- H. The CONTRACTOR, in executing the proposal, thereby certifies that he has or will meet the standards for affirmative compliance with the Fair Employment Practices requirements contained herein.

7.2 LABOR CODE.

- A. **Penalty.** The CONTRACTOR shall comply with Labor Code Section 1775. In accordance with said Section 1775 the CONTRACTOR shall forfeit as a penalty to the State of California, \$25.00 for each calendar day or portion thereof, for each worker paid less than the stipulated prevailing rates for such work or craft in which such worker is employed for any work done under the CONTRACT by him or by any subcontractor under him in violation of the provisions of the Labor Code and in particular, Labor Code Sections 1770 to 1780, inclusive. In addition to said penalty and pursuant to said Section 1775, the difference between such stipulated prevailing wage rates and the amount paid to each worker for each calendar day or portion thereof for which each worker was paid less than the stipulated prevailing wage rate shall be paid to each worker by the CONTRACTOR.
- B. **Hours of Labor.** Eight hours labor constitutes a legal day's work. The CONTRACTOR shall forfeit, as a penalty to the State of California, \$25.00 for each worker employed in the execution of the CONTRACT by the CONTRACTOR or any subcontractor under him for each calendar day during which such worker is required or permitted to work more than eight hours in any one calendar day and 40 hours in any one calendar week in violation of the provisions of the Labor Code, and in particular Section 1810 to 1815 thereof, inclusive, except that work performed by employees of CONTRACTORS in excess of eight hours per day, and 40 hours during any one week, shall be permitted upon compensation for all hours worked in excess of eight hours per day at not less than one and one-half times the basic rate of pay, as provided in said Section 1815.
- C. **Travel and Subsistence Payments.** Attention is directed to the requirements of Section 1773.8 of the Labor Code. The CONTRACTOR shall make travel and subsistence payments to each worker needed to execute the work in accordance with said requirements.
- D. **Employment of Apprentices.** Attention is directed to the provisions in Sections 1777.5, 1777.6, and 1777.7 of the Labor Code concerning the employment of apprentice by the CONTRACTOR or any subcontractor under him (Section 1777.5 shall not apply to prime CONTRACTs involving less than \$30,000 or 20 working days). The CONTRACTOR and any subcontractor under him shall comply with the requirements of 1777.6 and where applicable, of 1777.5 in the employment of apprentices.

To ensure compliance and complete understanding of the law regarding apprentices, and specifically the required ratio thereunder, each CONTRACTOR or subcontractor should, where some question exists, contact the Division of Apprenticeship Standards, 455 Golden Gate Avenue, San Francisco, California, or one of its branch offices prior to commencement of work on the public works CONTRACT. Responsibility for compliance with this section lies with the prime CONTRACTOR.

- E. **General Prevailing Wage Rates.** Pursuant to Section 1771 of the Labor Code, if this CONTRACT is for more than \$500, not less than the general prevailing rate of wages for work of a similar character in the county in which the work is to be performed shall be paid to all workers employed on this CONTRACT.

Pursuant to Section 1773 of the Labor Code, the general prevailing rate of wages in the county in which the work is to be done has been determined and the Department has listed these wage rates in

the Department of Transportation publication entitled General Prevailing Wage Rates. Future effective wage rates which have been predetermined and are on file with the Department of Industrial Relations are referenced but not printed in said publication.

If this CONTRACT is for more than \$500, the general prevailing wage rates set forth in the Department of Transportation publication entitled "*General Prevailing Wage Rates*", which establish minimum wages for this CONTRACT shall be posted by the CONTRACTOR in a prominent place at the site of the work.

- F. Assignment of Antitrust Actions.** The CONTRACTOR'S attention is directed to the following provisions of Government Code Section 4551 and 4552 (Stats. 1978, Ch. 414) which shall be applicable to the CONTRACTOR and his subcontractors on public works contracts or to the bidder on contracts for the purchase of goods, materials, or services:

"In entering into a public works CONTRACT or a subcontract to supply goods, services, or materials pursuant to a public works contract, the CONTRACTOR or subcontractor offers and agrees to assign to the awarding body all rights, title, and interest in and to all causes of action it may have under Section 4 of the Clayton Act (15 U.S.C. Sec. 15) or under the Cartwright Act (Chapter 2 commencing with Section 16700) of Part 2 of Division 7 of the Business and Professions Code), arising from purchase of goods, services, or materials pursuant to the public works CONTRACT or the subcontract. This assignment shall be made and become effective at the time the awarding body tenders final payment to the CONTRACTOR, without further acknowledgment by the parties."

"In submitting a bid to a public purchasing body, the bidder offers and agrees that if the bid is accepted, it will assign to the purchasing body all rights, title, and interest in and to all causes of action it may have under Section 4 of the Clayton Act (15 U.S.C. Sec 15) or under the Cartwright Act (Chapter 2 commencing with Section 16700) of Part 2 of Division 7 of the Business and Professions Code), arising from purchases of goods, materials, or services by the bidder for sale to the purchasing body pursuant to the bid. Such assignment shall be made and become effective at the time the purchasing body tenders final payment to the bidder."

- G. Payroll Records.** If this CONTRACT is for more than \$500, and involves the employment of people, the CONTRACTOR and each subcontractor shall comply with the following provisions. The CONTRACTOR shall be responsible for compliance with these provisions by his subcontractors.

1. Each CONTRACTOR and subcontractor shall keep an accurate payroll record, for a period of three (3) years from the date of completion of this CONTRACT, showing the full name, address, and social security number of each employee, his correct work classification, rate of pay for straight time and overtime, daily and weekly number of hours worked, itemized deductions made and actual per diem wages paid. They shall also indicate apprentices and ratio of apprentices to journeymen. The employee's address and social security number need only appear on the first payroll on which his name appears.
2. The CONTRACTOR shall submit weekly a copy of all payrolls, covering all the work included on the project or, if permitted by the ENGINEER on CONTRACTS of 30 working days or less, with each invoice the CONTRACTOR shall submit certified copies of all payrolls covering all the work included on the invoice. The copy shall be accompanied by a statement signed by the employer or his agent indicating that the payrolls are correct and complete and that the wage rates contained

therein are not less than those listed or referenced by the Department of Transportation. The CONTRACTOR and subcontractor shall use the certification set forth on Form HC-348 or the same certification appearing on the reverse side of optional Form HC-347, or any form with identical wording. The CONTRACTOR shall be responsible for the submission of copies of payrolls of all subcontractors. Payment will not be made on any invoice until required payrolls have been received.

3. The payroll records enumerated under subdivision (a) shall be certified and shall be available for inspection at all reasonable hours at the principal office of the CONTRACTOR on the following basis:
 - a. A certified copy of an employee's payroll record shall be made available for inspection or furnished to such employee or his or her authorized representative on request.
 - b. A certified copy of all payroll records enumerated in subdivision (a) shall be made available for inspection or furnished upon request to a representative of the body awarding the CONTRACT, the Division of Labor Standards Enforcement and the Division of Apprenticeship Standards of the Department of Industrial Relations.
 - c. A certified copy (with certain obliterations as required by Section 1776 of the Labor Code) of all payroll records enumerated in subdivision (a) shall be made available upon request to the public for inspection or copies thereof made; provided, however, that a request by the public shall be made through either the body awarding the CONTRACT, the Division of Apprenticeship Standards, or the Division of Labor Standards Enforcement. The public shall not be given access to such records at the principal office of the CONTRACTOR.
4. Each CONTRACTOR shall file a certified copy of the records enumerated in subdivision (a) with the entity that requested such record within 10 days after receipt of a written request.
5. The CONTRACTOR shall inform the body awarding the CONTRACT of the location of the records enumerated under subdivision (a), including the street address, city and county, and shall, within five working days, provide a notice of a change of location and address.
6. In the event of noncompliance with the requirements of this section, the CONTRACTOR shall have 10 days in which to comply subsequent to receipt of written notice specifying in what respects such CONTRACTOR must comply with this section. Should noncompliance still be evident after such 10-day period, the CONTRACTOR shall, as a penalty to the STATE or political subdivision on whose behalf the CONTRACT is made or awarded, forfeit \$25 for each calendar day, or portion thereof, for each worker, until strict compliance is effectuated. Upon the request of the Division of Apprenticeship Standards or the Division of Labor Standards Enforcement, such penalties shall be withheld from the progress then due.

Within 10 days, not including Saturdays, Sundays, or legal holidays, following completion of the work, the CONTRACTOR shall furnish to the ENGINEER a certified copy of each payroll record connected with the work performed on forms furnished by the ENGINEER.

H. Workers' Compensation. Pursuant to the requirements in Section 1860 of the Labor Code, the CONTRACTOR will be required to secure the payment of workers' compensation to the

CONTRACTOR's employees in conformance with the requirements in Section 3700 of the Labor Code.

1. Prior to the commencement of work, the CONTRACTOR shall sign and file with the COUNTY a certification in the following form:

"I am aware of the provisions of Section 3700 of the Labor Code which require every employer to be insured against liability for workers' compensation or to undertake self-insurance in accordance with the provisions of that code, and I will comply with such provisions before commencing the performance of the work of this contract."

2. This certification shall be included in the CONTRACT, and signature and return of the CONTRACT shall constitute signing and filing of the certificate. The CONTRACT shall be signed by the CONTRACTOR and returned, together with the CONTRACT bonds, copy of insurance policies, and Certificates of Insurance, with documents to verify any self-insurance coverage within 10 days, not including Saturdays, Sundays, and legal holidays, after the bidder has received the CONTRACT for execution.

8.1 SUBCONTRACTORS.

- A. A subcontractor is an individual, firm or corporation having a direct CONTRACT with the CONTRACTOR or with any other subcontractor for the performance of a part of the Work. In accordance with Section 4104 of the *Public Contract Code*, each CONTRACTOR, in his bid, shall include the name and location of each subcontractor who will perform work or labor, or render services to the CONTRACTOR in or about the Work in an amount in excess of one half of 1% of the CONTRACTOR'S total bid.
- B. The COUNTY reserves the right to approve all subcontractors. Such approval shall be a consideration to the awarding of the CONTRACT and unless notification to the contrary is given to the CONTRACTOR prior to the signing of the CONTRACT, the list of subcontractors which is submitted with his proposal will be deemed to be acceptable.
- C. The CONTRACTOR shall be as fully responsible to the COUNTY for the acts and omissions of his subcontractors and of persons either directly or indirectly employed by them, as he is for the acts and omissions of persons directly employed by him.
- D. Nothing contained in the CONTRACT Documents shall create any contractual relationship between any subcontractor and the COUNTY.
- E. The divisions or sections of the specifications are not intended to control the CONTRACTOR in dividing the Work among subcontractors or to limit the work performed by any trade.

8.2 RELATIONS OF CONTRACTOR AND SUBCONTRACTOR. The CONTRACTOR agrees to bind every subcontractor by the terms of the CONTRACT with the COUNTY, the General Conditions, Supplementary Conditions, and the drawings and specifications as far as applicable to his work, unless specifically noted to the contrary in a subcontract approved in writing as adequate by the COUNTY.

8.3 SUBCONTRACTS.

- A. Pursuant to the provisions of Sections 4100 to 4114 of the California *Public Contract Code*, inclusive, the CONTRACTOR shall not, without the consent of the COUNTY, either:

1. Substitute any persons as subcontractors in place of the subcontractors designated in his original bid without the consent of COUNTY. (The COUNTY'S consent can only be given in cases permitted by *Public Contract Code* Section 4107.)
2. Permit any subcontract to be assigned or transferred or allow any work to be performed by anyone other than the original subcontractor listed in his bid.
3. Sublet or subcontract any portion of the work in excess of one-half of one percent of his bid to which his original bid did not designate a subcontractor.

Should the CONTRACTOR violate any of the provisions of Sections 4100 to 4114, inclusive, of the *Public Contract Code*, his so doing shall be deemed a violation of this CONTRACT, and the COUNTY may either cancel the CONTRACT, or assess the CONTRACTOR a penalty in the amount of not more than ten (10) percent of the amount of the subcontract involved, or both.

9.1 SALES AND PAYROLL TAXES. Each CONTRACTOR, subcontractor, and material dealer shall include in their bid all applicable taxes including but not limited to sales tax and payroll taxes required by law.

10.1 CHANGE ORDER WORK. The COUNTY reserves the right to make changes in the work without impairing the validity of the CONTRACT. The COUNTY may make changes to the work, or suspend the work, and all such changes or suspension are within the contemplation of the parties and will not be a basis for compensable delay. Such changes may be made in accordance with any of the following methods:

- a. By written change order to the CONTRACT ordered by the Board of Supervisors.
- b. By written change order, signed by the Director of Facilities Management in the manner and amounts specified by Board Policy B-11.
- c. By written authorization, issued by the Director of Facilities Management, for items of work done under unit prices. The cost or credit for such added or omitted work shall be determined by multiplying the number of units added to or omitted from the work by the applicable unit price.

Upon receipt of a proposed Change Order from COUNTY, the CONTRACTOR shall submit a proposal in accordance with the requirements and limitations set forth in this "Change Orders" article, for work involved in the contemplated change.

The CONTRACTOR must submit a cost proposal within fifteen (15) calendar days after receipt of the proposed change order. The CONTRACTOR must submit cost proposals in less than fifteen (15) calendar days if requested by the COUNTY or if required by schedule limitations.

If the CONTRACTOR fails to submit the cost proposal within the 15-day period (or as requested), the COUNTY has the right to order the CONTRACTOR in writing to commence the work immediately on a force account basis and/or issue a lump sum change to the CONTRACT price in accordance with the COUNTY'S estimate of cost. If the change is issued based on the COUNTY estimate, the CONTRACTOR will waive his right to dispute the action unless within fifteen (15) calendar days following completion of the added/deleted work, the CONTRACTOR presents proof that the COUNTY'S estimate was in error.

If the COUNTY disagrees with the proposal submitted by CONTRACTOR, it will notify the CONTRACTOR in writing and the CONTRACTOR may elect to proceed under the DISPUTE article of this CONTRACT, or, in the event either party contests the price or time extension of Change work, or time is of the essence, the COUNTY

may issue a Construction Change Directive and the CONTRACTOR shall proceed with the work. The COUNTY will provide its opinion of the appropriate price and/or time extension in a "Response to Change Order Request." If the CONTRACTOR agrees with the COUNTY'S estimate, a change order will be issued by the COUNTY. If no agreement can be reached, the COUNTY shall have the right to issue the Change Order Directive setting forth its unilateral determination of the reasonable additions or savings in costs and time attributable to the extra or deleted work. Such determination shall become final and binding if the CONTRACTOR fails to submit a Claim in writing to the COUNTY, within twenty-one (21) days of the Change Order Directive, disputing the terms of such Directive. No dispute, disagreement or failure of the parties to reach agreement regarding the amount, if any, of any adjustment to the CONTRACT sum or CONTRACT time shall relieve the CONTRACTOR from the obligation to proceed with performance of the work, including extra work, promptly and expeditiously."

The CONTRACTOR will give notice of a requested change on his letterhead within seven (7) calendar days of discovery and, if the COUNTY agrees, a proposed change order will be issued on the COUNTY'S standard change order form.

If any change involves an increase or decrease in the cost of the CONTRACTOR'S work, a change order shall state the amount to be added or deducted from the CONTRACT amount, and the additional time, if any, needed for the performance of such work.

Any changes to the CONTRACT amount shall be in a lump sum mutually agreed to by the CONTRACTOR and the COUNTY, except that when, in the opinion of the COUNTY, such basis is not feasible the change to the CONTRACT amount shall be determined upon a cost-plus-percentage basis with a guaranteed maximum lump sum cost within the limitations provided by law.

Each lump sum quotation from the CONTRACTOR shall be accompanied by sufficiently detailed estimates to permit verification of totals in accordance with A through D listed below.

When the work is to be done on a cost-plus-percentage basis, the CONTRACTOR shall submit statements as required by the COUNTY showing all labor, material, and equipment costs incurred, and upon completion of the work, a summary of costs, including overhead and profit, and in accordance with Items A through D listed below.

Estimates for lump sum quotations and accounting for cost-plus-percentage work shall be limited to direct expenditures necessitated specifically by the subject extra work, and shall be segregated as follows:

- A. Labor.** The costs of labor will be the actual cost for wages prevailing locally for each craft or type of worker at the time the extra work is done, plus employer payments of payroll taxes and insurance, health and welfare, pension, vacation, apprenticeship funds, and other direct costs resulting from Federal, State or local laws, as well as assessment or benefits required by lawful collective bargaining agreements. The use of a labor classification which would increase the extra work cost will not be permitted unless the CONTRACTOR establishes the necessity for such additional costs. Labor costs for equipment operators and helpers shall be reported only when such costs are not included in the invoice for equipment rental.
- B. Materials.** The cost of materials reported shall be at invoice or lowest current price at which such materials are locally available in the quantities involved, plus sales tax, freight and delivery.
- C. Tool and Equipment Use.** No payment will be made for the use of tools which have a replacement value of \$100 or less. Regardless of ownership, the rates to be used in determining equipment use costs shall not exceed listed rates prevailing locally at equipment rental agencies, or distributors, at the time the work is performed.

D. Overhead, Profit and Other Charges. The mark-up for overhead and profit on work added to the CONTRACT shall be according to the following Schedule.

1. For work performed by the CONTRACTOR'S forces the added cost for overhead and profit shall not exceed fifteen (15%) percent of the net cost of the work, equipment, labor and materials.
2. For work performed by a subcontractor, the added cost for overhead and profit shall not exceed fifteen (15%) percent of the net cost of the work, equipment, labor and materials, to which the CONTRACTOR may add five (5) percent of the subcontractor's price of the work.
3. For work performed by a sub-subcontractor the added cost for overhead and profit shall not exceed fifteen (15 %) percent of the net cost for work, equipment, labor and materials to which sub-contractor and general CONTRACTOR may each add an additional five (5 %) percent of the total price from the lower tier subcontractor.
4. "Net Cost" is defined as consisting of costs of labor, materials and equipment use and/or rental only. The costs of applicable insurance and bond premium will be reimbursed to the CONTRACTOR and subcontractors at cost only, without mark-up.
5. The cost of direct supervision, except when provided by working foreman whose time is included above, of change order work when done exclusively, and not in conjunction or at the same time as, other work performed on the job and when approved in advance by the COUNTY'S authorized representative, including only payroll taxes, insurance, pension and direct costs for the labor of supervision may be charged to the change order. The cost of transportation, use of vehicle and other costs incurred by supervision will not be allowed.

For added or deducted work by subcontractors, the CONTRACTOR shall furnish to the COUNTY the subcontractor's signed detailed estimate of the cost of labor, material and equipment, including the markup by such subcontractor for overhead and profit. The same requirement shall apply to subcontractors.

For added or deducted work furnished by a vendor or supplier, the CONTRACTOR shall furnish to the COUNTY a detailed estimate or quotation of the cost to the CONTRACTOR for such work, signed by such vendor or supplier.

Any change in the work involving both extras and credits shall show a new total cost, including subcontracts. Allowance for overhead and profit, as specified therein, shall be applied if the net total cost is an extra; overhead and profit allowances shall not be applied if the net total cost is a credit. The estimated cost of deductions shall be based on labor and material prices on the date the CONTRACT was executed.

The CONTRACTOR shall identify any adjustment in time of the final completion of the Work as a whole which is directly attributable to the changed work within fifteen (15) calendar days of receipt of the proposed change order. The CONTRACTOR'S request for a change in time will be supported by a detailed schedule analysis including a schedule indicating the activities which have been affected and the additional time being requested.

- E.** For a change in time for the Work, the CONTRACTOR shall be entitled only to such adjustments where completion of the entire Work (critical path) is delayed due to the performance of the changed work. Failure to request extra time when submitting such estimate shall constitute waiver of the right to subsequently claim adjustment in time for final completion based upon such changed work.

- F. If the COUNTY and the CONTRACTOR fail to arrive at an agreement on the amount of extra cost, credit or time extension for a proposed change, a change order will be processed in the amount believed by the COUNTY to be reasonable, and the CONTRACTOR shall proceed with the work. If the CONTRACTOR believes that the amount or time stipulated in the change order is not reasonable for the work required, he may elect to issue a notification in accordance with the DISPUTES article for review by the COUNTY, stating therein the basis for his dispute with such change order.

Any change in the Work shall conform to the original Contract Documents insofar as they may apply without conflict to the conditions involved in the change.

Payment for additional work or extras, if any, shall become due and payable in accordance with the provisions for payment in the CONTRACT.

CONTRACTOR shall not reserve a right to assess impact cost, extended job site costs, extended overhead, and/or constructive acceleration at a later date as related to any and all changes. All costs or estimated costs must be supported with full schedule and cost documentation with each proposed change within the prescribed submission times. If a request for a change is denied and the CONTRACTOR disputes the denial, the CONTRACTOR must supply the aforementioned documentation to support his claim under the DISPUTES article of this CONTRACT. No claims shall be allowed for impact, extended overhead costs, and/or construction acceleration due to the multiplicity of changes and/or clarifications. Any attempt by CONTRACTOR to change or modify the change order form (sample included herein) shall void the form, including any letters the CONTRACTOR may issue in conjunction therewith.

All alterations, extensions of time, extra and additional work and other changes authorized by these specifications or any part of the CONTRACT may be made without securing consent of the surety or sureties on the CONTRACT bonds.

10.2 CHANGE ORDERS AND LABOR RATES GUIDELINES. The following are guidelines for preparing change orders:

A. Labor Rates.

1. To establish the labor rate for each classification and trade, a breakdown shall be submitted to the COUNTY.
2. Labor rates are based on current prevailing state and federal wages. Only those benefits mandated by law or a valid labor CONTRACT are paid by the COUNTY.
3. Payroll taxes shall be paid as mandated by law. Labor related insurances shall be paid according to industry standard average.
4. No other costs related to labor shall be paid by COUNTY.

B. Change Orders.

1. Change orders shall be prepared in accordance with the project CONTRACT.
2. No insurance costs are paid by COUNTY, except for labor insurances specified in this guideline under section 1 titled "LABOR RATES".
3. Material cost shall be broken down on a separate sheet, and for those jobs designated as time and material shall be supported by valid invoices from suppliers.

4. Hours for non-productive labor, such as non-working foremen or general foremen, shall be paid only when justified in the opinion of the COUNTY, and approved by the COUNTY. The total number of nonproductive labor hours shall be limited to a maximum of 15% of the total number of productive labor hours.
5. Cost of use of special equipment shall be paid when justified in the opinion of the COUNTY, and approved by the COUNTY. Equipment refers to special equipment that is needed to perform that specific job, and does not include the usual tools customarily required for that trade. Small tools costs are not paid by COUNTY.
6. Material transportation costs are paid by COUNTY when justified in the opinion of the COUNTY, and approved by the COUNTY'S authorized representative.
7. Overhead, profit and fees on subcontracts, are paid according to the CONTRACT.
8. No costs other than those designated above shall be paid by COUNTY. The percentages of overhead and fee allowed with change orders have been established to account for any other direct or indirect costs that might be incurred due to the change order.

10.3 AUDIT. The COUNTY shall have the right to examine and audit all books, estimates, records, CONTRACTS, documents, bid documents, subcontracts, and other data of the CONTRACTOR (including computations and projections) related to negotiating, pricing, or performing the modification in order to evaluate the accuracy and completeness of the cost or pricing data at no additional cost to the COUNTY.

The CONTRACTOR shall make available at its office at all reasonable times the materials described in paragraph above, for examination, audit, or reproduction, until 4 years after final payment under this CONTRACT.

The CONTRACTOR shall insert a clause containing all the provisions of this 10.3, including this paragraph, in all subcontracts over \$10,000 under this CONTRACT.

11.1 NON-COMPLIANCE WITH CONTRACT REQUIREMENTS. In the event the CONTRACTOR, after receiving written notice from the COUNTY of non-compliance with any requirement of this CONTRACT, fails to promptly initiate appropriate action to comply with the specified requirement, the COUNTY shall have the right to withhold payment for work completed under the CONTRACT until the CONTRACTOR has complied with the notice or has initiated such action as may be appropriate to comply, within a reasonable period of time. The CONTRACTOR shall not be entitled to any extension of CONTRACT time or payment for any costs incurred for work under this article.

Should the CONTRACTOR abandon the Work called for under the CONTRACT, or assign his CONTRACT, or unnecessarily and unreasonably delay the work, or willfully violate or perform the work in bad faith, the COUNTY shall have the power to notify the CONTRACTOR to discontinue all work or any part thereof under this CONTRACT, and thereupon the CONTRACTOR shall cease to continue said work or such part thereof as the COUNTY may designate, and the COUNTY shall have the power to employ such persons as it may consider desirable, and to obtain by CONTRACT, purchase, hire or otherwise, such implements, tools, material or materials as the COUNTY may deem advisable to work at and be used to complete the work herein described, or such part thereof as shall have not been completed, and to use such material as it may find upon the site of the work, and to charge the expense of such labor and material, implements and tools to the CONTRACTOR, and the expense so charged shall be deducted and paid by the COUNTY out of such monies as may either be due, or may at any time thereafter become due to the CONTRACTOR under the CONTRACT.

11.2 TERMINATION.

- A. Termination for Breach.** If the CONTRACTOR should be adjudged bankrupt or if he should make a general assignment for the benefit of his creditors, or if a receiver should be appointed on account of his insolvency, or if he or any of his subcontractors should violate any of the provisions of the CONTRACT, the COUNTY may serve written notice upon him and his surety of its intention to terminate CONTRACTOR'S performance hereunder, said notice shall contain the reasons for such intention to terminate CONTRACTOR'S performance, and, unless within ten (10) calendar days after serving of said notice, such violation shall cease and satisfactory arrangements for correction thereof be made, CONTRACTOR'S performance shall, upon the expiration of said ten (10) calendar days, cease and terminate. In the event of any such termination, the COUNTY shall immediately serve written notice thereof upon the surety and the CONTRACTOR, and the COUNTY may take over the CONTRACTOR'S work and prosecute the same to completion by CONTRACT or by any other method it may deem advisable, for the account and at the expense of the CONTRACTOR, and the CONTRACTOR and his surety shall be liable to the COUNTY for any excess cost occasioned the COUNTY thereby, and in such event the COUNTY may without liability for so doing take possession of and utilize in completing the work, such materials, appliances, plants, and other property belonging to the CONTRACTOR as may be on the site of the work and necessary therefore.
- B. Termination for Convenience.**
1. If the construction of the project herein is damaged, which damage is determined to have been proximately caused by an Act of God, in excess of 5% of the CONTRACT amount, provided that the work damaged is built in accordance with applicable building standards and the plans and specifications, then the COUNTY may, without prejudice to any other right or remedy, terminate the CONTRACT.
 2. The COUNTY may terminate performance of work under this CONTRACT in whole or in part, if the COUNTY determines that a termination is in the COUNTY'S interest. The COUNTY shall terminate by delivering to the CONTRACTOR a Notice to Terminate specifying the extent of termination and the effective date.
 3. After receipt of such Notice, and except as directed by the COUNTY, the CONTRACTOR shall immediately proceed with the following obligations, regardless of any delay in determining or adjusting any amounts due under this clause:
 - a. Stop work as specified in the notice.
 - b. Place no further subcontracts or orders (referred to as subcontracts in this clause) for materials, services, or facilities, except as necessary to complete any continued portion of the CONTRACT.
 - c. To terminate all subcontracts to the extent they relate to the work terminated.
 - d. With approval or ratification to the extent required by the COUNTY, settle all outstanding liabilities and termination settlement proposals arising from termination of subcontracts; the approval or ratification will be final for purposes of this clause.
 - e. As directed by the COUNTY, transfer title and deliver to the COUNTY (1) the fabricated or unfabricated parts; work in progress, completed work, supplies, and other material produced or acquired for the work terminated; and (2) the completed or partially completed plans, drawings, information, and other property that, if the CONTRACT had been completed, would be required to be furnished to the COUNTY.

- f. Complete performance of work not terminated.
 - g. Take any action that may be necessary, or that the COUNTY may direct, for the protection and preservation of the property related to this CONTRACT that is in the possession of the CONTRACTOR and in which the COUNTY has or may acquire an interest.
 - h. Use its best efforts to sell, as directed or authorized by the COUNTY, any property of the types referred to in subparagraphs above; provided, however, that the CONTRACTOR (1) is not required to extend credit to any purchaser and (2) may acquire the property under the conditions prescribed by, and at prices approved by the COUNTY. The proceeds of any transfer or disposition will be applied to reduce any payments to be made by the COUNTY under this CONTRACT, credited to the price or cost of the work, or paid in any other manner directed by the COUNTY
4. After termination, the CONTRACTOR shall submit a final termination settlement proposal to the COUNTY in the form and with the certification prescribed by the COUNTY. The CONTRACTOR shall submit the proposal promptly, but no later than thirty (30) days from the effective date of termination. If the CONTRACTOR fails to submit the proposal within the time allowed, the COUNTY may determine, on the basis of information available, the amount, if any, due the CONTRACTOR because of the termination and shall pay the amount determined.
 5. Subject to subparagraph 3b above, the CONTRACTOR and the COUNTY may agree upon the whole or any part of the amount to be paid because of the termination. The amount may include a reasonable allowance for profit on work done. However, the agreed amount, may not exceed the total CONTRACT price as reduced by:
 - a. the amount of payments previously made and;
 - b. the CONTRACT price of work not terminated. The CONTRACT shall be amended with a Change Order, and the CONTRACTOR paid the agreed amount.
 6. If the CONTRACTOR and COUNTY fail to agree on the whole amount to be paid the CONTRACTOR because of the termination of work, the COUNTY shall pay the CONTRACTOR the amounts determined as follows:
 - a. For CONTRACT work performed before the effective date of termination, the total (without duplication of any terms) of:
 - (i) The cost of this work;
 - (ii) The cost of settling and paying termination settlement proposals under terminated subcontracts that are properly chargeable to the terminated portion of the CONTRACT if not included in subdivision (i) above; and
 - (iii) A sum, as profit on (i) above, determined by the COUNTY to be fair and reasonable; however, if it appears that the CONTRACTOR would have sustained a loss on the entire CONTRACT had it been completed, the COUNTY shall allow no profit under this subdivision (iii).
 - b. The reasonable costs of settlement of the work terminated including:
 - (i) Accounting, clerical, and other expenses reasonably necessary for the preparation of termination settlement proposals and supporting data; and

- (ii) Storage, transportation, and other costs incurred, reasonably necessary for the preservation, protection, or disposition of the termination inventory.
7. Except for normal spoilage, the COUNTY shall exclude from the amounts payable to the CONTRACTOR the fair value, as determined by the COUNTY, of defective work, and of property that is destroyed, lost, stolen, or damaged so as to become undeliverable.
 8. The CONTRACTOR shall have the right to make a claim under the DISPUTES article, from any determination made by the COUNTY.
 9. In arriving at the amount due the CONTRACTOR, there shall be deducted:
 - a. All unliquidated advance or other payments to the CONTRACTOR under the terminated portion of this CONTRACT;
 - b. Any claim which the COUNTY has against the CONTRACTOR under this CONTRACT; and
 - c. The agreed price for, or the proceeds of sale of, materials, supplies, or other things acquired by the CONTRACTOR or sold under the provisions of this clause and not recovered by or credited to the COUNTY.
 10. If the termination is partial, the CONTRACTOR may file a proposal with the COUNTY for a Change Order of the price(s) of the continued portion of the CONTRACT. The COUNTY shall process any Change Order agreed upon. Any proposal by the CONTRACTOR for an equitable adjustment under this clause shall be requested within thirty (30) days from the effective date of termination unless extended in writing by the COUNTY.
 11. The COUNTY may, under the terms and conditions it prescribes, make partial payments and payments against costs incurred by the CONTRACTOR for the terminated portion of the CONTRACT, if the COUNTY believes the total of these payments will not exceed the amount to which the CONTRACTOR will be entitled. If the total payments exceed the amount finally determined to be due, the CONTRACTOR shall repay the excess to the COUNTY upon demand, together with interest.
 12. Unless otherwise provided in this CONTRACT or by statute, the CONTRACTOR will maintain all records and documents relating to the terminated portion of this CONTRACT for 4 years after final settlement. This includes all books and other evidence bearing on the CONTRACTOR'S costs and expenses under this CONTRACT. The CONTRACTOR shall make these records and documents available to the COUNTY, State and/or the U.S. Government or their representatives' at all reasonable times, without any direct charge.

12.1 TIME OF WORK. The CONTRACTOR shall commence work on this project immediately upon receipt of the written Notice to Proceed and shall perform the work diligently to completion within the number of working days specified in the CONTRACT. Neither site access nor physical work shall be commenced before the CONTRACT is fully executed, and bonds, insurance and the schedule are submitted as required by the Contract Documents. No work shall be done on Saturday, Sunday and holidays and no work shall be performed outside of normal working hours without the prior written consent of the COUNTY, unless required by these Specifications. See: Working Hours.

12.2 UNAVOIDABLE DELAYS

A. Time Extension.

1. The CONTRACTOR will be granted an extension of time for completion of the Work beyond that named in the Contract Documents, for delays which may result through causes beyond the control

of the CONTRACTOR and which he could not have avoided by the exercise of care, prudence, foresight and diligence. The appropriate extension of time shall constitute full compensation. Costs associated with extended overhead will not be considered.

2. If the CONTRACTOR is allowed extensions of time in which to complete the Work equal to the sum of all unavoidable delays, plus any adjustments of CONTRACT time due to CONTRACT change orders, during such extension of time liquidated damages shall not be charged to the CONTRACTOR.
3. Unavoidable delays within the meaning of this section shall be those caused by Acts of God or of the public enemy, fire, epidemics, or strike. There will be no liquidated damages for delays as described within this paragraph.
4. Delays in the performance of parts of the work which may in themselves be unavoidable, but do not necessarily prevent or delay the performance of critical activity(s) while the activity(s) is on the Critical Path, will not be considered as unavoidable delays within the meaning of the CONTRACT and shall not be the basis of a claim for delay.

B. Weather. Inclement weather shall not be a prima facie reason for granting a time extension. The CONTRACTOR shall make every effort to continue work under prevailing conditions. However, if the inclement weather prevents the CONTRACTOR from beginning at the usual starting time, or prevents the CONTRACTOR from proceeding with seventy-five percent (75%) of the normal labor and equipment force towards completion of the day's current Critical Path activities (shown on the most current, and accepted schedule update) for a period of at least five (5) hours, and the crew is dismissed as a result thereof, the COUNTY will designate such time as unavoidable delay and grant a one (1) calendar day, non-compensable, time extension.

C. Notice of Delays.

1. Whenever the CONTRACTOR foresees any delay in the performance of a Critical Path work activity, and in any event immediately upon the occurrence of any delay which he regards as an unavoidable delay, the CONTRACTOR shall notify the COUNTY in writing of such delay and its cause, in order that the COUNTY may take immediate steps to prevent, if possible, the occurrence or continuance of the delay, and may determine whether the delay is to be considered avoidable or unavoidable, how long it continues, and to what extent the prosecution and completion of the work are to be delayed thereby.
2. After the completion of any part or the whole of the Work, the COUNTY, in calculating the amount due the CONTRACTOR, will assume that any and all delays which have occurred have been avoidable delays, except such delays as shall have been called to the attention of the COUNTY at the time of their occurrence and found by the COUNTY to have been unavoidable as substantiated by a change order. The CONTRACTOR shall make no claims that any delay not called to the attention of the COUNTY at the time of its occurrence has been an unavoidable delay.

12.3 REQUEST FOR TIME EXTENSION. In the event the CONTRACTOR requests an extension of CONTRACT time for unavoidable delay, justification shall be submitted no later than seven (7) calendar days after the initial occurrence of any such delay. When requesting time for proposed change orders, the request(s) must be submitted with the proposed change order with full justification. If the CONTRACTOR fails to submit justification he shall waive his right to a time extension at a later date. Justification must be based on the currently accepted CONTRACT schedule as updated at the time of occurrence of delay or execution of work

related to any change(s) in the scope of work. The justification must include a schedule, including, but not limited to, the following information:

- A. The duration to perform the activity relating to the change(s) in the work and the resources (manpower, equipment, material, etc.) required to perform these activities within the stated duration.
- B. Logical activity ties to the CONTRACT schedule for the proposed changes and/or delay showing the activity/activities in the schedule whose start or completion dates are affected by the change and/or delay.

The COUNTY, after receipt of such justification and supporting evidence, shall make its finding of fact. The COUNTY'S decision shall be final and conclusive and the COUNTY will advise the CONTRACTOR in writing of such decision. If the COUNTY finds that the CONTRACTOR is entitled to any extension of CONTRACT time, the COUNTY'S determination as to the total number of days of extension shall be based upon the latest updated version of the approved CONTRACT schedule.

In the event the CONTRACTOR disagrees with the COUNTY'S decision, the CONTRACTOR shall be required to submit a claim pursuant to the DISPUTE article.

13.1 SUPERVISION AND CONSTRUCTION PROCEDURES. The CONTRACTOR shall supervise and direct the work. The CONTRACTOR shall be solely responsible for all construction means, methods, techniques, sequences, procedures, project safety, and shall coordinate all portions of the Work under the CONTRACT, including the relations of the various trades to the progress of the Work, in accordance with the provisions of the CONTRACT Documents.

The CONTRACTOR shall be responsible to the COUNTY for the acts and omissions of the CONTRACTOR'S employees, subcontractors, and their agents and employees, and any other persons performing any of the work under a CONTRACT with the CONTRACTOR.

The CONTRACTOR is an independent CONTRACTOR and nothing in the CONTRACT Documents shall be interpreted to make the CONTRACTOR an agent of the COUNTY.

13.2 SUPERVISION. Within seven (7) days after the Notice to Proceed, the CONTRACTOR shall provide to the COUNTY an organization chart outlining key job personnel. The CONTRACTOR will also provide a Letter of Authority or Corporate Resolution for the individual(s) authorized to sign documents on its behalf, i.e., payment requests, change orders, inspection reports, etc.

The CONTRACTOR shall employ, during the progress of the Work, a competent Project Superintendent and any necessary assistants, as approved by the COUNTY. The Project Superintendent shall not be changed except with the consent of the Authorized Representative of COUNTY, unless the Superintendent proves to be unsatisfactory to the CONTRACTOR or ceases to be in his employ. The COUNTY shall be notified immediately of any new Superintendent appointed to the Work and the CONTRACTOR shall submit qualifications for approval. The Superintendent shall represent the CONTRACTOR and all directions given to him shall be as binding as if given to the CONTRACTOR.

The COUNTY shall be supplied at all times with the name and telephone number of a person in charge of or responsible for the Work, who can be reached for emergency work twenty-four (24) hours a day, seven (7) days a week.

13.3 CONDUCT OF WORK. In connecting one kind of work with another, marring or damaging same will not be permitted and, in the event such occurs, shall be corrected by the CONTRACTOR at its cost prior to acceptance by the COUNTY. Should improper work of any trade be covered by another which results in damage or defects, the whole work affected shall be made good by the CONTRACTOR without expense to COUNTY.

13.4 CONTRACTOR'S RESPONSIBILITY FOR WORK AND PROPERTY. The CONTRACTOR shall continuously maintain adequate protection of the Work from damage and shall protect the COUNTY'S property from injury or loss in connection with this CONTRACT. He shall make good any such damage, injury, or loss, except what may be directly due to errors in the Contract Documents or caused by agents or employees of the COUNTY. He shall adequately protect adjacent property as provided by law and the Contract Documents.

The CONTRACTOR shall preserve and protect all structures, equipment, and vegetation (such as trees, shrubs, and grass) on or adjacent to the Work site, which are not to be removed and which do not unreasonably interfere with the work required under this CONTRACT.

The CONTRACTOR shall protect from damage all existing improvements and utilities at or near the Work site and on adjacent property of a third party, the locations of which are made known to or should be known by the CONTRACTOR. The CONTRACTOR shall repair any damage to those facilities, including those that are the property of a third party, resulting from failure to comply with the requirements of this CONTRACT or failure to exercise reasonable care in performing the Work. If the CONTRACTOR fails to repair the damage promptly, the COUNTY may have the necessary work performed and charge the cost to the CONTRACTOR.

13.5 UTILITIES. Unless otherwise provided for under separate sections herein, CONTRACTOR will arrange all water, gas, and electricity required for construction purposes until acceptance of the Work. CONTRACTOR shall pay for such services unless otherwise specifically noted.

Utilities shall not be interrupted except with the approval of the COUNTY. A two (2) work day written notice is required prior to any and all interruptions. Interruptions shall be scheduled so as to minimize duration and disruption to existing operations.

- A. The CONTRACTOR shall send notices, make all necessary arrangements, and perform all other services required in the care and maintenance of all public utilities.
- B. Enclosing or boxing in, for protection of any public utility equipment, shall be done by the CONTRACTOR. Upon completion of the Work, the CONTRACTOR shall remove all enclosures, and leave in a finished condition.
- C. All connections to public utilities shall be made and maintained in a manner so as not to interfere with the continuing use of same by the COUNTY during the entire progress of the Work.

13.6 WORKING HOURS. All work shall be performed on a working day basis during the customary working hours of the trades involved unless otherwise specified in this CONTRACT. Work performed by the CONTRACTOR of his own volition outside such established working hours shall be at no additional expense to the COUNTY and without COUNTY approval.

It is expressly stipulated that no laborer, workman, or mechanic employed at any time by the CONTRACTOR or by any subcontractor(s) under this CONTRACT upon the Work or any part thereof, shall be required or permitted to work thereon more than eight (8) hours during any one calendar day and forty (40) hours during any one

calendar week, except, as provided by Section 1815 of the *California Labor Code*. It is further expressly stipulated that for each and every violation of Sections 1811-1815, inclusive, of the *California Labor Code*, all the provisions of which are deemed to be incorporated herein, said CONTRACTOR shall forfeit, as a penalty to COUNTY, twenty-five dollars (\$25.00) for each laborer, workman, or mechanic employed in the execution of this CONTRACT by CONTRACTOR for each calendar day during which said laborer, workman, or mechanic is required or permitted to work more than eight hours in any one calendar day and forty hours in any one calendar week in violation of the provisions of said Sections of the *California Labor Code*.

The CONTRACTOR, and each subcontractor, shall keep an accurate record showing the names of and actual hours worked each calendar day and each calendar week by all laborers, workmen, and mechanics employed by them in connection with the Work contemplated by this CONTRACT, which record shall be open at all reasonable hours to the inspection of the COUNTY or its officers or agents and to the Division of Labor Standards Enforcement of the Department of Industrial Relations.

No construction work shall be done on Saturdays, Sundays or COUNTY holidays and no work shall be performed outside of normal working hours without the prior written consent of the COUNTY. In any event, all work shall be subject to approval of the COUNTY. Prior to start of such work, the CONTRACTOR shall arrange with the COUNTY for the continuous or periodic inspection of the Work and testing of materials, when necessary. If requests are made by the CONTRACTOR for permission to work overtime, nights, Saturdays, Sundays or COUNTY holidays, and such requests are granted, the CONTRACTOR shall bear all extra expense to the COUNTY for inspection and other incidental expenses caused by such overtime work. If CONTRACTORS are requested, in the interest of the COUNTY, to work overtime by the COUNTY, or if overtime work is specifically required by these specifications, all extra expense of inspection will be paid by the COUNTY.

13.7 MATERIAL AND EQUIPMENT. Materials, equipment, and articles incorporated into the Work shall be new and of equal quality to the types and grades specified. When not particularly specified, the CONTRACTOR shall submit for approval satisfactory evidence as to the kind and quality of material. See Division III, Section 3.1.2 "Trade Names or Equals" for requirements and procedure for submitting alternative material, articles, or equipment.

All materials shall be delivered so as to insure a speedy and uninterrupted progress of the Work. All materials shall be stored so as to cause no obstruction and so as to prevent overloading of any portion of the structure on the Work site, and the CONTRACTOR shall be entirely responsible for damage or loss by weather, theft, vandalism, or other cause.

Materials shall be stored to assure the preservation of their quality and fitness for the Work. Stored materials shall be reasonably accessible for inspection. When considered necessary by the COUNTY, stored materials shall be placed on wooden platforms or on other hard, clean surfaces and not directly on the ground, and shall be placed under cover when so directed.

13.8 USE OF PREMISES. The CONTRACTOR shall maintain the entire premises under his control in an orderly condition. He shall store his apparatus, materials, supplies and equipment in such a manner as will not interfere with the progress of his work or the work of other contractors.

13.9 OPERATIONS AND STORAGE. The CONTRACTOR shall confine all operations (including storage of materials) on COUNTY premises to areas authorized or approved by the COUNTY.

Temporary buildings (e.g., storage sheds, shops, offices) and utilities may be erected by the CONTRACTOR only with the approval of the COUNTY and shall be built with labor and materials furnished by the CONTRACTOR without expense to the COUNTY. The temporary buildings and utilities shall remain the property of the CONTRACTOR and shall be removed by the CONTRACTOR at his expense upon completion of the work.

The CONTRACTOR shall, under regulations prescribed by the authority having jurisdiction, use only established roadways, or use temporary roadways constructed by the CONTRACTOR when and as authorized by the authority having jurisdiction. When materials are transported in performance of the Work, vehicles shall not be loaded beyond the loading capacity recommended by the manufacturer of the vehicle or prescribed by any Federal, State, or COUNTY regulation. When it is necessary to cross curbs or sidewalks, the CONTRACTOR shall protect them from damage. The CONTRACTOR shall repair, or pay for the repair, of any damaged curbs, sidewalks, or roads.

13.10 HEAT/POWER/LIGHT. Unless otherwise specified or already provided by the COUNTY, the CONTRACTOR shall:

- A. Provide heat, as necessary to protect all work, materials, and equipment against injury from dampness and cold;
- B. Provide heat as necessary in the area where work is to be done to provide the minimum temperature recommended by the supplier or manufacturer of the material;
- C. Provide electric power and light as required for performance of the Work.

14.1 ACCIDENT PREVENTION. In performing this CONTRACT, the CONTRACTOR shall provide for protecting the lives and health of employees and other persons; preventing damage to property, materials, supplies, and equipment; and avoiding work interruptions. For these purposes, the CONTRACTOR shall:

- A. Provide a copy of its safety program;
- B. Provide appropriate safety barricades, signs, and signal lights;
- C. Comply with standards issued by the U.S. Government, State, COUNTY, and other governing agencies having jurisdiction;
- D. Ensure that any additional measures the COUNTY determines to be reasonably necessary for this purpose are taken.

The CONTRACTOR shall maintain an accurate record of exposure data on all accidents incident to work performed under this CONTRACT resulting in death, traumatic injury, occupational disease, or damage to property, materials, supplies, or equipment. The CONTRACTOR shall report this data in the manner prescribed by the COUNTY.

Before beginning excavation for a trench 5 feet or more in depth, CONTRACTOR shall provide evidence of having obtained a permit from the authority having jurisdiction.

Nothing herein shall be deemed to allow use of shoring, sloping, or protective systems less effective than those required by the Construction Safety Orders of the California Division of Industrial Safety.

14.2 RESPONSIBILITY FOR COMPLIANCE WITH CAL-OSHA. All work, materials, work safety procedures and equipment shall be in full accordance with the latest Cal-OSHA rules and regulations.

CONTRACTOR warrants that he and each of his subcontractors shall, in performance of this CONTRACT, comply with each and every compliance order issued pursuant to Cal-OSHA. The CONTRACTOR assumes full and total responsibility for compliance with Cal-OSHA standards by his subcontractors as well as himself. The cost of complying with any order and/or payment of any penalty assessed pursuant to Cal-OSHA shall be borne by the CONTRACTOR. Nothing contained therein shall be deemed to prevent the CONTRACTOR and his subcontractors from otherwise allocating between themselves responsibility for compliance with Cal-OSHA requirements; provided, however, that the CONTRACTOR shall not thereby, in any manner whatsoever, be relieved of his responsibility to the COUNTY as herein set forth.

14.3 TOXIC AND HAZARDOUS MATERIALS AND WASTE

- A. **Asbestos.** Operations which may cause release of asbestos fibers into the atmosphere shall meet the requirements of *Title 8 CCR General Industrial Safety Orders*, Section 5208 and California law. Some operations which may cause such concentrations include sanding, grinding, abrasive blasting, sawing, drilling, shoveling, or otherwise handling materials containing asbestos so that dust will be raised.
- B. **Toxic Materials.** Operations which release toxic materials into the atmosphere shall meet the requirements of *Title 8 CCR General Industrial Safety Orders*. Some operations which may release such materials include use of adhesives, sealants, paint, and other coatings.
- C. **Lead-based Paint.** Lead-based paint is prohibited. Lead-based paint is defined as:
 - 1. Any paint containing more than five-tenths of one percentum lead by weight (calculated as lead metal in the total non-volatile content of the paint) or the equivalent measure of lead in the dried film of paint applied or both; or
 - 2. For paint manufactured after June 22, 1977, any paint containing more than six one-hundredths of one percentum lead by weight (calculated as lead metal) in the total content of the paint or the equivalent measure of lead in the dried film or paint already applied.
- D. **Hauling and Disposal.** All hauling and disposal shall meet requirements of Title 22 CCR, Division 4, Chapter 30, "Minimum Standards for Management of Hazardous and Extremely Hazardous Wastes."
- E. **Asbestos Prohibited.** No products or materials containing asbestos shall be incorporated into the Work without the prior written approval of the COUNTY.

15.1 COUNTY-FURNISHED PROPERTY. The COUNTY may furnish to the CONTRACTOR property as identified in the specification(s) to be incorporated or installed into the Work or used in performing the CONTRACT. The listed property will be furnished f.o.b. railroad cars at the place specified in the CONTRACT or f.o.b. truck at the project site. The CONTRACTOR is required to accept delivery. When the property is delivered, the CONTRACTOR shall verify its quantity and condition and acknowledge receipt in writing to the COUNTY within twenty-four (24) hours of delivery, also specifying any damage to or shortage of the property as received. All such property shall be installed or incorporated into the Work at the expense of the CONTRACTOR, unless otherwise indicated in this CONTRACT.

Each item of property to be furnished under this clause shall be identified by the CONTRACTOR in a schedule by quantity, item, and description. Schedule form will be provided by the COUNTY.

The CONTRACTOR shall be held responsible for all material delivered to him and deductions will be made from any moneys due him to make good any shortages and deficiencies, from any cause whatsoever, which may occur after such delivery.

The CONTRACTOR shall set up accounting records and establish an inspection procedure as approved by the COUNTY.

16.1 BENEFICIAL OCCUPANCY. The COUNTY shall have the right to take possession of or use any completed or partially completed portion of the Work. The COUNTY'S possession or use shall not be deemed an acceptance of any Work under the CONTRACT. The CONTRACTOR will continue to pay for any portion of the utilities which he is using.

While the COUNTY has such possession or use, the CONTRACTOR shall be relieved of the responsibility for the loss of or damage to that portion of the Work resulting from the COUNTY'S possession or use. If CONTRACTOR believes the partial possession or use by the COUNTY will delay the progress of the Work or will cause additional expense to the CONTRACTOR, CONTRACTOR shall immediately submit a written request for an equitable adjustment in the CONTRACT price or the time of completion. COUNTY will then consider such request and, if in its judgment it is justified, the COUNTY will modify the CONTRACT in writing accordingly. In the event the CONTRACTOR disagrees with the COUNTY'S decision, the CONTRACTOR shall be required to submit a claim pursuant to the DISPUTE article.

17.1 INSPECTION AND TESTING.

- A.** The CONTRACTOR shall maintain an adequate inspection system and perform such inspections as will ensure that the work called for by this CONTRACT conforms to CONTRACT requirements. The CONTRACTOR shall maintain complete inspection records and make them available to the COUNTY. The COUNTY shall at all times have access to the Work, and the CONTRACTOR shall provide proper facilities for such access and for inspection.
- B.** COUNTY inspections and tests are for the sole benefit of the COUNTY and do not:
 - 1. Relieve the CONTRACTOR of responsibility for providing adequate quality control measures;
 - 2. Relieve the CONTRACTOR of responsibility for damage to or loss of the material before Acceptance;
 - 3. Constitute or imply Acceptance; or
 - 4. Affect the continuing rights of the COUNTY after Acceptance regarding latent defects, gross mistakes, fraud or the COUNTY'S rights under any warranty or guarantee.
- C.** The presence or absence of a COUNTY inspector does not relieve the CONTRACTOR from any CONTRACT requirement, nor is the inspector authorized to change any term or condition of the specifications without the COUNTY'S written authorization.
- D.** The CONTRACTOR shall promptly furnish, without additional charge, all facilities, labor, and material reasonably needed for performing such safe and convenient inspections and tests as may be required by the COUNTY. The COUNTY may charge to the CONTRACTOR any additional cost of inspection or test when work is not ready at the time specified by the CONTRACTOR for inspection or test, or when prior rejection makes re-inspection or retest necessary. Special, full size, and performance tests shall be performed as described in the CONTRACT.
- E.** The CONTRACTOR shall, without charge, replace or correct work found by the COUNTY not to conform to CONTRACT requirements, unless in the public interest the COUNTY consents to accept the work with

an appropriate adjustment in CONTRACT price. The CONTRACTOR shall promptly segregate and remove rejected material from the premises.

- F. If, before Acceptance of the Work, the COUNTY decides to examine already completed work by removing it or tearing it out, the CONTRACTOR, on request, shall promptly furnish all necessary facilities, labor, and material. If the work is found to be defective or nonconforming in any material respect due to the fault of the CONTRACTOR or its subcontractors, the CONTRACTOR shall defray the expenses of the examination and of satisfactory reconstruction. However, if the work is found to meet CONTRACT requirements, the COUNTY shall issue a Change Order for such removal and reinstallation.
- G. The CONTRACTOR shall at all times maintain proper facilities and provide safe access for inspection by the COUNTY to all parts of the work, and to the shops wherein the work is in preparation. Where the specifications require work to be specially tested or approved, it shall not be tested or covered up without timely notice to the COUNTY of its readiness for inspection and without the approval or consent of COUNTY. Should any such work be covered up without such notice, approval, or consent, it must, if required by COUNTY, be uncovered for examination at the CONTRACTOR'S expense.
- H. The CONTRACTOR shall notify the COUNTY at least one (1) work day in advance of the time scheduled for the inspection. Should the CONTRACTOR fail to notify the COUNTY and proceed with work requiring inspection, all such work is rejected, and no further work shall be done on that portion of the project until the rejected work is accepted by the COUNTY. Should the CONTRACTOR request acceptance of such rejected work the COUNTY shall, at the CONTRACTOR'S expense, secure the services of private material testing laboratories, consulting ENGINEERS or licensed land surveyors, who shall certify that said work does in fact conform to the requirements of the Contract Documents. The work previously rejected shall be accepted by the COUNTY after receipt of such certification if the COUNTY approves of such certification.
- I. If the CONTRACTOR does not promptly replace or correct rejected work, the COUNTY may (1) by CONTRACT or otherwise, replace or correct the work and charge the cost to the CONTRACTOR or (2) terminate for default the CONTRACTOR'S right to proceed.
- J. Construction review of the CONTRACTOR'S performance by the COUNTY is not intended to include the review of the adequacy of the CONTRACTOR'S safety measures, in, on, or near the construction site.
- K. The COUNTY will pay for initial testing services specified to be performed by the COUNTY. When initial tests indicate non-compliance with the Contract Documents, subsequent retesting occasioned by the non-compliance shall be performed by the same testing COUNTY, and costs thereof will be deducted by the COUNTY from the CONTRACT sum.

17.2 INSPECTION BY OTHER JURISDICTIONS. Whenever any part of the Work to be performed is under the jurisdiction or control of another public entity, including but not limited to: The United States Government, State of California, or COUNTY, such work shall be subject to inspection by the officials of such entities and it must pass inspection, in addition to COUNTY inspection, and such other inspections as may otherwise be provided for in the Contract Documents.

17.3 FINAL INSPECTION AND TESTS. The CONTRACTOR shall give the COUNTY at least ten (10) calendar days advance written notice of the date the Work will be fully completed and ready for final inspection and tests. Final inspection and tests will be started within ten (10) calendar days from the date specified in the

aforementioned notice unless the COUNTY determines that the Work is not ready for final inspection and so informs the CONTRACTOR.

18.1 ACCEPTANCE OF THE WORK. After the final inspection by COUNTY and all the CONTRACT documentation has been received, it will be recommended to the COUNTY Board of Supervisors to accept the Work and file a Notice of Completion. Upon approval of the Notice of Completion, a copy will be sent to the CONTRACTOR. (See final payment clause.) Upon Acceptance of the Work, CONTRACTOR will be relieved of the duty of maintaining and protecting the Work. Neither determination by the COUNTY that the Work is complete, nor Acceptance thereof, shall operate as a bar to COUNTY'S claim against CONTRACTOR pursuant to CONTRACTOR'S warranty and guarantees.

Partial payments shall not be construed as acceptance of any part of the Work.

In judging the Work, no allowance for deviations from the drawings and specifications will be made, unless already approved in writing at the time and in the manner as called for herein.

COUNTY shall be given adequate opportunity to make any necessary arrangements for fire insurance and extended coverage.

The Acceptance of the Work will not be recommended until all requirements of the Contract Documents are complete and approved by the COUNTY. This shall include, but is not limited to, all construction, guarantee forms, parts lists, schedules, tests, operating instructions, as-built drawings, and all other documentation identified by the Contract Documents.

19.1 CONTRACTOR'S WARRANTY AND GUARANTEE

- A.** CONTRACTOR warrants that all materials and equipment furnished under this CONTRACT shall be new unless otherwise specified, and that all Work performed under this CONTRACT conforms to the CONTRACT requirements and is free of any defect whether performed by the CONTRACTOR or any subcontractor or supplier.
- B.** This warranty shall continue for a period of one (1) year from the date of filing of Notice of Completion on the Work. The Performance Bond shall remain in force during the warranty period.
- C.** The CONTRACTOR shall remedy at the CONTRACTOR'S expense any damage to COUNTY-owned or controlled real or personal property, when that damage is the result of:
 - 1. The CONTRACTOR'S failure to conform to CONTRACT requirements or
 - 2. Any defect of equipment, material, workmanship, or design furnished by the CONTRACTOR.
- D.** The CONTRACTOR shall restore any work damaged in fulfilling the terms and conditions of this Article. The CONTRACTOR'S warranty with respect to work repaired or replaced will run for one (1) year from the date of repair or replacement.
- E.** The COUNTY shall notify the CONTRACTOR, in writing, within a reasonable time after the discovery of any failure, defect, or damage. The CONTRACTOR shall within ten (10) calendar days after being notified in writing by the COUNTY of any work not in accordance with the requirements of the CONTRACT or any defects in the Work, commence, and perform with due diligence, all work necessary to fulfill the terms of this Article. If the CONTRACTOR fails to remedy any defect, or damage within fourteen (14) calendar

days after receipt of notice, the COUNTY shall have the right to replace, repair, or otherwise remedy the defect, or damage at the CONTRACTOR'S expense. Payment due to the ENGINEER from the COUNTY for extra Engineering services required in the enforcement of CONTRACTOR'S guarantee after Acceptance of the Work shall be paid to the COUNTY by the CONTRACTOR.

- F. In the event of any emergency constituting an immediate hazard to health or safety of COUNTY employees, property, or licensees, when caused by work of the CONTRACTOR that is not in accordance with the CONTRACT requirements, the COUNTY may undertake at CONTRACTOR'S expense and without prior notice, all work necessary to correct such hazardous condition(s).
- G. With respect to all warranties, express or implied, from subcontractors, manufacturers, or suppliers for work performed and materials furnished under this CONTRACT, the CONTRACTOR shall:
 - 1. Obtain all warranties that would be given in normal commercial practice;
 - 2. Require all warranties to be executed, in writing, for the benefit of the COUNTY, unless directed otherwise by the COUNTY; and
 - 3. Enforce all warranties for the benefit of the COUNTY, unless otherwise directed by the COUNTY.
- H. This warranty shall not limit the COUNTY'S rights under the Inspection and Acceptance section(s) of this CONTRACT with respect to latent defects, gross mistakes, or fraud.

20.1 ENVIRONMENTAL PROTECTION

A. Dust Control.

- 1. The CONTRACTOR shall provide any and all dust control required.
- 2. Whenever the CONTRACTOR is negligent in providing dust control, the Agency shall order the CONTRACTOR to provide such dust control. If the CONTRACTOR does not comply promptly with such order, the Agency shall have the authority to provide such dust control and charge the CONTRACTOR therefore by deducting the cost from progress payments to the CONTRACTOR as such costs are incurred by the Agency. The Agency shall not be held responsible for schedule delays due to actions taken by Agency to mitigate the failure of the CONTRACTOR in providing dust control.

The CONTRACTOR is cautioned that failure to control fugitive dust may result in fines being levied by the South Coast Air Quality Management District to both the CONTRACTOR and the County of Riverside, as owner. The CONTRACTOR shall be fully responsible for payment of all fines pertaining to air pollution control violations, resulting from CONTRACTOR'S operations related to the construction CONTRACT, which may be levied against both the CONTRACTOR and the County of Riverside by the AQMD or other regulatory agencies. The CONTRACTOR'S attention is directed to Section 7-1.01 "Laws to be Observed" of the Standard Specifications. The cost of all fines levied against the County of Riverside will be deducted from any moneys due or which may become due to the CONTRACTOR, unless other payment arrangements are made by the CONTRACTOR.

Dust control of all of the CONTRACTOR'S operations is required 24 hours per day, 7 days a week for the duration of the CONTRACT, and until the disturbed soil is permanently stabilized. The CONTRACTOR shall take every precaution to prevent emissions of fugitive dust from the project site, from locations of stockpiled materials, from unpaved driving surfaces, from haul vehicles, from inactive construction areas, and from all other operations of the CONTRACTOR. The

CONTRACTOR shall plan for and carry out proper and efficient measures to prevent his operations from producing dust in amounts damaging to property or which constitute a public nuisance, or which cause harm to persons living or working in the vicinity of the work. Of particular concern are emissions of PM10 particles, which are fine particulate matter of 10 microns or less and which are associated with sickness and death from respiratory disease.

The CONTRACTOR shall furnish and post dust mitigation signs, which shall be, at a minimum, in accordance with the "AQMD Signage Recommendations", attached hereto. Additional copies are available upon request from the ENGINEER. The sign shall include the CONTRACTOR'S phone number which shall be maintained on a 24 hour basis. The sign message, size and design, including any deviations from the signage recommendations, shall be approved by the ENGINEER prior to fabrication. The CONTRACTOR shall respond to complaints by mobilizing equipment and personnel at the construction site within 2 hours of each complaint to control fugitive dust.

Attention is directed to AQMD Rule 403.1, which applies to all contracts within the Coachella Valley area of Riverside County. That AQMD rule requires the CONTRACTOR to take specified dust control actions when prevailing wind speeds exceed 25 miles per hour. Wind forecasts, AQMD Rules and other related information are provided by AQMD at 1-800-CUT-SMOG and at www.aqmd.gov .

Any days on which the CONTRACTOR is prevented from working, due to the requirements of AQMD rules, will be considered as non-working days, in accordance with Section 8-1.06 "Time of Completion" of the Standard Specifications.

The CONTRACTOR shall utilize the "Best Available Control Measures" of controlling fugitive dust, as prepared by the AQMD. For projects within the Coachella Valley, the "Reasonably Available Control Measures" may be employed, if effective within the context of the AQMD rules. However, if fugitive dust crosses the project boundary, more effective control measures, including the "Best Available Control Measures" shall be implemented.

A site-specific fugitive dust control plan shall be submitted to the Consultant and Agency for review and approval at least **10 days** prior to the start of construction. Additionally, for projects outside of the Coachella Valley which meet the criteria for AQMD plan approval, the CONTRACTOR shall submit the dust control plan to AQMD for approval. AQMD plan submittal criteria is defined in AQMD Rule 403 as being for projects that will have disturbed surface area in excess of 100 acres, or for projects with a scope of work which requires the movement of more than 10,000 cubic yards of soil on each of any three working days.

A sample plan and other pertinent information is attached, and additional copies are available from the ENGINEER upon request. The fugitive dust control plan shall include the "Reasonably Available Control Measures" and "Best Available Control Measures" of controlling fugitive dust, as may be appropriate and necessary, including but not limited to watering, application of chemical dust suppressants, wind fencing, covering of haul vehicles, haul vehicle bed-liners, covering or chemically stabilizing stored materials, phased grading, planting of vegetation, the use of a 24 hour environmental observer, and track-out controls at locations where unpaved construction accesses intersect with paved roads. The use of chemical stabilizers, which are approved by all environmental regulatory agencies, and the use of reclaimed water is encouraged. If water is intended as a primary dust control tool, the dust control plan shall provide for at least one 2,000 gallon water truck for every 4 acres of disturbed soil, unless otherwise approved by the ENGINEER.

If the Construction ENGINEER determines that the project scope and the forecasted weather conditions are such that the CONTRACTOR'S work is unlikely to be a source of dust emissions, the Construction ENGINEER has the authority to waive the requirements for submittal of a dust control plan and for placement of the dust control signs described herein. However, the CONTRACTORS responsibilities for the control of fugitive dust and the other requirements of this section may not be waived.

A completion notice will not be filed, and final payment will not be made to the CONTRACTOR until the areas of disturbed soil on the construction site, including roadway shoulders, are suitably stabilized for long term control of fugitive dust. **The successful CONTRACTOR shall attend an AQMD PM10 Dust Control Program training session, and furnish evidence of attendance to the ENGINEER.** Attendance at AQMD training seminars can be scheduled through AQMD at 1-866-861-DUST (1-866-861-3878) or by email to dustcontrol@aqmd.gov . Current AQMD certification of previous attendance will be accepted. At that training session, the successful CONTRACTOR will be furnished with the AQMD prepared Rule 403 and Rule 403.1 implementation handbooks, which include the "Best Available Control Measures" and "Reasonably Available Control Measures", and other associated information, including a listing of suggested dust control related devices, materials and chemicals.

The signature of the CONTRACTOR on the Proposal constitutes acknowledgement by the CONTRACTOR of the dust control requirements established by law and described herein, and the enforceability of those requirements.

When the CONTRACT includes a bid item for Dust Abatement, full compensation for conformance with these dust abatement requirements, including labor, equipment, materials, developing water supply and incidentals, shall be paid under the Bid Item "Dust Abatement" on a lump sum basis, up to the fixed bid price, for the work performed.

When the CONTRACT does not include a bid item for Dust Abatement, full compensation for conformance with these dust abatement requirements, including labor, equipment, materials, developing water supply and incidentals, shall be considered as included in the various items of work, and no additional compensation will be allowed therefore.

B. Excessive Noise.

1. The CONTRACTOR shall use only such equipment on the Work and in such state of repair that the emission of sound therefrom is within the noise tolerance level of that equipment as established by CAL-OSHA.
2. Should the Agency determine that the muffling device on any equipment used on the Work is ineffective or defective so that the noise tolerance of such equipment is exceeded, such equipment shall not, after such determination by the Agency, be used on the Work until its muffling device is repaired or replaced so as to bring the noise tolerance level of such equipment within such standards.

C. Pollution Control, Cleaning.

1. The CONTRACTOR shall not, in connection with the Work, discharge any smoke, dust, or other contaminants into the atmosphere which are in violation of South Coast Air Quality Management District standards or discharge any fluids or materials into any lake, river, stream, or channel as will violate regulations of State of California Water Resources Board. The CONTRACTOR shall control accumulation of waste materials and rubbish and dispose of waste materials and rubbish off-site at a minimum of weekly intervals. Burning of materials is not permitted.

END OF DIVISION II GENERAL PROVISIONS