



ECONOMIC DEVELOPMENT AGENCY – COUNTY OF RIVERSIDE

ADDENDUM NO. 004

TO BIDDING DOCUMENTS, CONTRACT, BASIC SPECIFICATIONS, AND SPECIAL REQUIREMENTS
FOR
RANCHO JURUPA REGIONAL SPORTS COMPLEX

Bidders are advised that the Contract Documents for the above referenced contract are hereby amended in the following manner and in the following manner only:

A. GENERAL ITEMS

1. All provisions of this Addendum No. 004 are hereby incorporated into the contract documents, and bidders shall account for all provisions pursuant to this Addendum No. 004 in submitting their bid proposals. Each bidder shall include a dated and signed copy of this Addendum No. 004 with his sealed bid proposal.
2. The cutoff for RFI's has changed to **Thursday, October 21, 2010 at 2:30pm**

B. PLAN & SPECIFICATION ITEMS

1. Change the play equipment model number in the construction legend items "D" and "E" on detail "A" sheet CD-2, to 31360-1-2.
2. Specification Section 13000.F.1. shall be changed to "The **OWNER** is responsible for the site survey and staking the building location,"
3. The quantity of picnic tables on CP-1 and CP-2, item 16 shall be changed to **52**.
4. The retaining walls located along the north property line shall be constructed per detail H, sheet C2 as indicated on sheets C3 and C4. The retaining walls located on the north and west sides of the soccer field adjacent to the concrete paving shall be constructed per details A and D, sheet CD-3 as indicated on sheet CP-2.
5. Detail A and D on sheet CD-3 show a typical mow curb against wall, where turf occurs. It then references detail F, on CD-1 which is the monument sign, which is incorrect. A mow curb detail has been included as part of this addendum.

6. Specification Section 02890.08 Field Conditions **Part A** shall be removed from the specifications.
7. The contractor shall be required to prepare the Storm Water Pollution Prevention Plan (SWPPP) for the project. The SWPPP shall meet all requirements of the **2009-0009-DWQ Construction general permit** which can be found at:
http://www.swrcb.ca.gov/water_issues/programs/stormwater/constpermits.shtml
8. The connection to the existing flood control down drain shall be made utilizing a concrete collar in accordance with APWA STD 380-4.
9. The electrical plan sheets (E-1, E-2, E-3, E-4, E-5, E-6, E-7, E-8, E-9, E-10) dated 5/10/10 shall be replaced with the attached sheets dated 5/27/10. Information missing from the original sheets has been added.
10. All work within 5' of the synthetic turf system, both above and below ground, must be performed by a qualified contractor according to the project specifications. Pre-qualifications shall be submitted for the synthetic field installers **AND** sub-drain and crushed rock preparation installers. The pre-qualifications can be submitted **within 24 hours after the bid opening by the three apparent low bidders**.
11. The 15" drain line indicated on sheet C9 should be revised to the 18" perforated drain as indicated within the specs. The 48" perforated drain line adjacent to the parking lot is the infiltration trench drain for water quality purposes and is considered to be part of the perimeter drain system for the synthetic turf fields. In addition, all drain inlets and laterals that connect to the perimeter drain system are considered part of the synthetic turf sub-drainage system and must be installed by a qualified sub-drainage subcontractor with 10 fields in 3 years experience per the project specifications. The connections must be made to 5' outside of the trench/synthetic turf area where a qualified underground utility contractor may pick up the connection and install the rest of the upstream system.
12. The sidewalk that is referred to in detail C sheet C-3 is the public sidewalk within the County right-of-way that is indicated on the SP sheets. This sidewalk per County standard is a 4" thick sidewalk. Interior sidewalks (outside of the R/W) shall be 6" thick per the CP sheets.
13. Sheets C7 and C11 were labeled incorrectly; the scale of these sheets is 1"=30'.
14. Wire note #1 on sheet IP-1 specifies "All valve control / common wires shall be installed in a schedule 40 gray PVC conduit per detail "B" sheet ID-1". The detail reference should be **detail "I" sheet ID-1**. All common, pilot and spare wires shall be installed inside schedule 40 PVC grey conduit in a **continuous route** from controllers to all the remote control valve locations.
15. The pipe for all drinking fountain lines shall be schedule 40 PVC.
16. All 6" irrigation pipe shall be Class 200 PVC Ring-Tite.

17. The exterior of the trash enclosure walls shall have a stone veneer wainscot to match the electrical enclosure on detail "E" sheet CD-2.

18. Refer to Stone Veneer Column detail included in Addendum #4 for detail on stone veneer columns at the shade structure posts.

DATED: October 20, 2010

By: _____
Jason Plotkin, Project Manager

10/20/2010
Date Received by Bidder

By:  _____
Bidder's Signature

Vince Germann
Typed or Printed Name



ECONOMIC DEVELOPMENT AGENCY – COUNTY OF RIVERSIDE

ADDENDUM NO. 005

TO BIDDING DOCUMENTS, CONTRACT, BASIC SPECIFICATIONS, AND SPECIAL REQUIREMENTS
FOR
RANCHO JURUPA REGIONAL SPORTS COMPLEX

Bidders are advised that the Contract Documents for the above referenced contract are hereby amended in the following manner and in the following manner only:

A. GENERAL ITEMS

1. All provisions of this Addendum No. 005 are hereby incorporated into the contract documents, and bidders shall account for all provisions pursuant to this Addendum No. 005 in submitting their bid proposals. Each bidder shall include a dated and signed copy of this Addendum No. 005 with his sealed bid proposal.

B. PLAN & SPECIFICATION ITEMS

1. All concrete paving shall be 3,250 psi per plans. The reference to 4,000 psi concrete in the Geotechnical Report shall be revised to 3,250 psi.
2. Detail 'C', Sheet CD-3 shall be modified to have the gravel base and geotextile fabric extend 18" beyond the edge of the concrete pavers.
3. Construct a 6" wide by 16" deep concrete curb to separate the asphalt paving and permeable pavers. Install continuous #4 rebar 3" below top of curb and 1" deep score joints at 10' O.C. The top of curb is to be flush with the adjacent pavers and asphalt paving.
4. The existing stump and tree along Loring Ranch are to be removed.
5. The reference to hydroseed turf on sheets PP-1 and PP-2 shall be removed. The base bid shall be sod turf as specified on the plans.
6. The alternate bid item for the football striping shall also include increasing the length of the synthetic turf blades to a minimum of 2.5".

DATED: October 22, 2010

By: _____
Jason Plotkin, Project Manager

10/22/2010
Date Received by Bidder

By: 
Bidder's Signature

Vince Germann
Typed or Printed Name

CERTIFICATE OF RESOLUTION

I, ANDREW J. MANDELL, the Assistant Secretary of VALLEYCREST LANDSCAPE DEVELOPMENT, INC., a California corporation, do hereby certify that on March 30, 2010, the following resolutions were adopted by unanimous consent of the Directors of VALLEYCREST LANDSCAPE DEVELOPMENT, INC., in accordance with Article III, Section 3.10 of the By-Laws of the Corporation:

RESOLVED, that the Board of Directors have authorized and they do hereby authorize Burton S. Sperber, Richard A. Sperber, Bill Babineau, Sean Brosnan, Richard P. Bruttig, Kurt Buxton, Po Chen, Brian Chesnut, William N. Cohen, Jeffrey A. Colton, Stanley A. Colton, Paul Comstock, Mike Cooper, John Cunningham, Michael L. Dingman, Thomas C. Donnelly, Kelly F. Duke, Pete Dykstra, Jeffrey Gainey, Vincent S. Germann, Darby Gilmer, Phil Graham, Philip Graham IV, Dan Harper, Betty Mallory Heron, Jeff Hiners, James B. Hogan, Peter Hunn, Jim Hyatt, Rich Jacoby, Andy Johnson, Cliff Johnson, Karl V. Kaliebe, Jay Kassabian, Sandy Kayser, Matilde Lavenant, Matthew Leathers, William A. Leathers, Jeff Lennon, John Lohman, Andrew J. Mandell, Brendan McFadden, Greg K. Motschenbacher, Matthew Mudek, Thomas Powell, Brian Prantil, Joseph R. Parinella, Holly Rabbai, George W. Reber, William Ropp, Eileen M. Saldivar, Julianne Seeley, James Wallace or any of them to execute and deliver in the name of and for and on behalf of this Corporation, any and all bids, bid bonds, contracts, contract bonds, authorizations pertaining to contracts, liens and releases, and credit applications;

FURTHER RESOLVED, that the Board of Directors have authorized and they do hereby authorize Mark Carlos, Virginia Comas, Jean Creeger, Lisa Griffiths, Louis Gutierrez, Judy Hogan, Gary Hoopengardner, Cindy James, Walter Johnson, Steve Koschak, Matilde Lavenant, Judith Leiby, Elina Luterstein, Cheryl Mathes, Eva Morrissey, Marie Moyer, Holly Rabbai, Eileen M. Saldivar, Glen Sharrar, Gina Smith, Teresa Thomas, Jyssette Vargas, or any of them, to execute and deliver in the name of and for and on behalf of this Corporation, credit applications, billings and releases;

FURTHER RESOLVED, that the Secretary or Assistant Secretary of the Corporation is hereby authorized and directed to execute a Certificate of the Secretary certifying to the passage of these resolutions;

FURTHER RESOLVED, that any and all firms, persons, corporations and other entities, including, without limiting effect, public entities, shall be entitled to rely on the authority of any one of the foregoing persons to bind this corporation by the execution and the delivery of any such bids, bid bonds, contracts, contract bonds, and authorizations pertaining to contracts, liens and releases;

FURTHER RESOLVED, that the authority herein contained, shall remain in effect until the persons, firm, corporation or other entity relying upon the authority herein contained receive written notice to the contrary and that all previous authorizations heretofore given with respect to the matters herein contained are revoked; provided, however, that this revocation shall not affect the validity of any instrument hereinabove referred to that was executed by any person or persons who at the time of such execution was duly authorized to act.

DATED: March 30, 2010



ANDREW J. MANDELL
Assistant Secretary

Field Qualifications



ValleyCrest
Landscape Development
PROJECT PROFILE

Lions Field Redevelopment Fullerton, California

WEC Engineering

26672 Towne Centre Drive
Foothills Ranch, California
(949) 600-5105 / (949) 600-5106 FAX
Contact: Mr. Scott Walker
Project Manager

Completion Date: Ongoing

Total Contract Value: \$ 5,814,000

Self-Performed Work: \$ 2,389,000

Multi-Project Contracts: Value

Grading / Demo	\$ 325,000
Concrete - Structural	\$ 1,305,000
Concrete - Flatwork	\$ 400,000
Fence	\$ 410,000
Electrical	\$ 500,000
Pile Walls	\$ 210,000
Structural Steel / Carpentry	\$ 275,000

Landscape Architect

CTDLA

1903 St. Simons Place
Fullerton, California 92831
(714) 773-0899

Contact: Mr. Craig Thomas Duncan



Project consist of 215,000 sf of synthetic turf.



Slip form of box culvert.

Synopsis:

ValleyCrest was the successful low bidder for the much needed renovation of Lions Field, a historic park located in Fullerton, California. The job consisted of clearing 15 acres of hardscape, trees, buildings, fence and light fixtures and replacing with updated amenities. A double 5' w x 8' h box culvert was also constructed to improve the drainage in the surrounding area. Soldier pile walls were installed to retain the slopes of the neighboring Hillcrest Park. The 4 baseball/softball and football fields are completely installed with synthetic turf.



La Pata Park
San Clemente, California

Owner:

City of San Clemente
910 Calle Negocio
San Clemente, CA 92673
(949) 361-8267 / (949) 492-5289 Fax
Contact: Mr. Tim Shaw
Project Manager



Aerial view of park in early construction

Completion Date: Ongoing

Total Contract Value: \$ 10,900,000

Self-Performed Work: \$ 5,390,000

Multi-Project Contracts: Value

Multi-Project Contracts:	Value
Grading	\$ 200,000
Concrete & Asphalt	\$ 1,300,000
Fencing	\$ 470,000
Fabric Shade Structures	\$ 100,000
Masonry / Pavers	\$ 450,000
Carpentry	\$ 100,000
Synthetic Turf	\$ 1,050,000
Play Surface / Equipment	\$ 200,000
Misc. Building Trades	\$ 240,000
Electrical	\$ 1,400,000

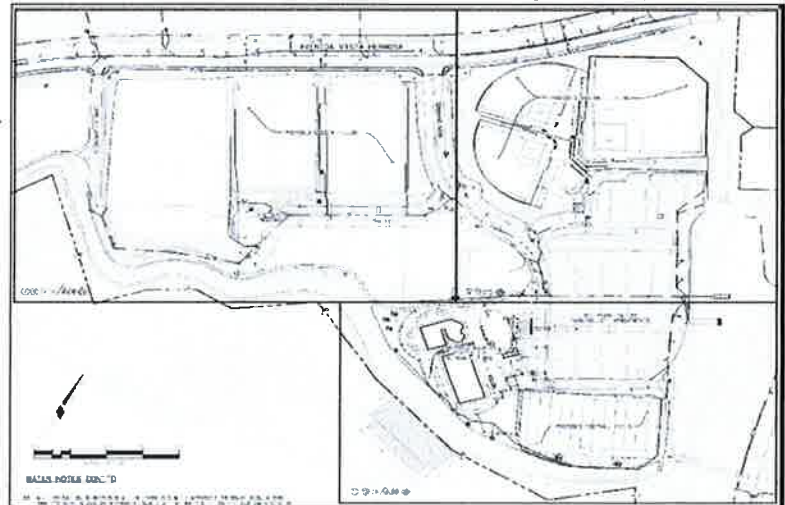

Overview of 45 Acre Sports Complex w/ Three Synthetic Turf Fields

Landscape Architect

Summers / Murphy and Partners, Inc.

34197 Coast Highway, Suite 200

Dana Point, California 92629

(949) 443-1446 / (949) 443-1631 FAX

Contact: Mr. Patrick Murphy



ValleyCrest
Landscape Development
PROJECT PROFILE

**Expo Center Sports Fields
Exposition Park
Los Angeles, California**

Owner

The State of California
c/o Friends of Expo
5510 Lincoln Boulevard, Suite 100
Playa Vista, California 90094
(310) 832-1881

Contact: Mr. Steve Soboroff
Chairman

Completion Date: Month / Year

Total Contract Value: \$ 4,600,000

Self-Performed Work: \$ 3,340,000

Multi-Project Contracts: Value

Concrete:	\$	120,000
Masonry:	\$	15,000
Concrete:	\$	120,000
Masonry:	\$	15,000
Fencing:	\$	150,000
Synthetic Turf:	\$	475,000
Pre-Engineered Building:	\$	300,000
Electrical:	\$	65,000



Fields during synthetic turf installation



Completed installation serves as two practice or one competition field

Landscape Architect

ValleyCrest Design Group - HRP Studio
3242 Halladay, Suite 203
Santa Ana, California 92705
(714) 557-5852 / (714) 557-7621 FAX

Contact: Mr. Kurt Buxton
Vice-President, Design Lead

Synopsis:

The Friends of Expo are a group of concerned citizens who spearheaded the effort to raise funds and promote the construction of soccer fields in park space adjacent to the Los Angeles Coliseum. ValleyCrest was awarded a contract to design and build the deceptively complex project. ValleyCrest's design team satisfied all of the stringent requirements of the Department of the State Architect and navigated the project through the complex approval process to secure all of the necessary entitlements. The scope of work consists of two synthetic soccer fields, a restroom, fencing, site concrete, irrigation, and planting. As part of the project ValleyCrest worked with Friends of Expo to explore options and develop a methodology for covering the fields with a protective cover that allows overflow parking during events at the adjacent Coliseum.



**Torrance Unified School District
(4) New Synthetic Track & Fields
Torrance, California**

Torrance Unified School District

2334 Plaza del Amo
Torrance, California 90501
(310) 972-6511 / (310) 972-6221 FAX
Contact: Ms. Kathleen Hodge



Completion Date: August, 2009

Total Contract Value: \$ 8,700,000

Self-Performed Work: \$ 3,448,000

Multi-Project Contracts: Value

Concrete \$ 280,000.00

Asphalt \$ 650,000.00

Electrical \$ 720,000.00

Fence \$ 190,000.00

Synthetic Track Surface \$ 1,262,000.00

Grandstand Bleachers \$ 2,150,000.00



Football season 2009 opening day at Torrance High School

Landscape Architect

Westberg + White, Inc.

14471 Chambers Road, Suite 210
Tustin, California 92780
(714) 508-1780 / (714) 508-1790 FAX

Contact: Mr. Paul Dennis Westberg

Synopsis:

ValleyCrest won this public works bid to install four new synthetic track and fields for the School District of Torrance. The work consisted of upgrading the stadium amenities such as new grandstand bleachers, electrical and PA system, new synthetic track surface, all sports field equipment, and preparing the field with a base and drainage system for the 360,000 sf of synthetic turf. The turf was installed under a separate contract. ValleyCrest used its 50 years of sports field construction to deliver this project on a strict 4 month schedule to have all the fields ready by opening day of the 2009 football season.

KEY to COLOR CODES

- High School Fields
- Municipal Fields
- Collegiate Fields
- Minor and Major League Professional Fields:
- Club Sports / Military / Other:

SPORTS FIELD PROJECTS
 Selected Sports Field Projects Constructed by ValleyCrest Companies - 2004 to Present

Project Name	Total Project Value	Project Role	No. of Fields	Self-Performed Work Scope	Year Built	Customer or Facility Owner	Designer
ValleyCrest Landscape Development, Inc., - All Offices Nationally							
All Fields (Natural and Synthetic Turf) Combined 135 Total Fields Constructed							
La Pata Park San Clemente, California	\$ 10,900,000	Prime	6	Site landscaping along with field sub-grade, Brock drain mat, and irrigation for three synthetic fields along with root zone and natural turf for three baseball fields. All utilities, DG pavements, skinned surfaces, and site amenities.	2011*	City of San Clemente 910 Calle Negocio San Clemente, California 92673 (949) 361-8267 / (949) 492-5289 FAX Attention: Mr. Tim Shaw, Project Manager	Summers, Murphy, and Partners, Inc., 34197 Coast Highway, Suite 200 Dana Point, California 92629 (949) 443-1446 / (949) 443-1631 FAX Attention: Mr. Patrick Murphy
Salt River Fields at Talking Stick MLB Diamondbacks and Rockies Spring Training Facility Scottsdale, Arizona *In Progress	\$ 7,596,174	Sub	12	Site landscaping along with field sub-grade, sub-drains, irrigation, root zone mix, laser grading, sod, skinned areas grow-in maintenance	2011*	M. A. Mortenson Company 3100 West Ray Road, Suite 101 Chandler, Arizona 85226 (480) 839-5944 / (480) 839-5996 FAX Attention: Mr. Ty Bohlander	Ten Eyck Landscape Architects 808 East Osborn Road, Suite 100 Phoenix, Arizona 85014 (602) 468-0505 / (602) 468-5775 FAX Attention: Ms. Christine Ten Eyck
Florida Marlins Playing Field Miami, Florida *In Progress	\$ 1,344,984	Sub	1	Construction of a vertically drained Major League baseball field including excavation for drainlines, irrigation, sand-based rootzone mix, bermuda sod, warming track, infield mix and bull pen mounds.	2010*	Marlins Stadium Developer LLC clo Hunt / Moss, A Joint Venture 2450 South Tibbs Avenue Indianapolis, Indiana 46206 (305) 325-0577 / (305) 325-0765 FAX Attention: Mr. Michael Delano, Jr.	Rosenberg Gardner Design 5190 North West 167th Street, Suite 111 Miami, Florida 33014 (305) 620-7781 / (305) 620-7787 FAX Attention: Mr. Ken Gardner
Arlington Heights Sports Park Riverside, California DESIGN-BUILD	\$ 13,700,000	Prime Design-Build	7	38 Acre municipal sports park with baseball, softball, football, soccer, and multi-sport fields, basketball courts, playground, water play area restroom/concession building, parking, plazas, and all related infrastructure	2010	City of Riverside 3900 Main Street, 6th Floor Riverside, California 92522 (951) 826-5000 / (951) 826-4122 FAX Attention: Mr. Carl Carey	HRP Studio / ValleyCrest Design Group 3242 Halladay, Suite 203 Santa Ana, California 92705 (714) 557-5852 / (714) 557-7621 FAX Attention: Mr. Kurt Buxton, Principal
Village at the Park Sports Complex Camarillo, California	\$ 11,195,000	Prime	14	55 Acre municipal sports park with baseball, softball, football, soccer, and multi-sport fields, basketball courts, playground, water play area restroom/concession building, parking, plazas, and all related infrastructure	2010	Pleasant Valley Recreation and Park District 1605 East Burnley Street Camarillo, California 93010 (619) 895-7177 / (619) 235-0735 FAX Attention: Mr. Joseph Sholle	MJS Design Group 511 30th Street Newport Beach, California 92663

Project Name	Total Project Value	Project Role	No. of Fields	Self-Performed Work Scope	Year Built	Customer or Facility Owner	Designer
NAS San Diego San Diego, California DESIGN-BUILD	\$ 2,169,000	Prime Design-Build	2	Design-Build, synthetic turf fields including sub-drains, irrigation, landscape planning, and hard-scape	2010	Department of the Navy 901 M. Street, S.E. Washington Navy Yard, Building 166 Washington, DC 20374-5095 (202) 685-8243 Attention: Ms. Carolyn Labanowski	DeLorenzo, Incorporated 1775 Hancock Street, Suite 150 San Diego, California 92110 (619) 295-5115 / (619) 297-2354 FAX Attention: Mr. Nicholas DeLorenzo, ASLA
MCAS Fallon Fallon, Nevada DESIGN-BUILD	\$ 1,174,422	Prime Design-Build	1	Design-Build, synthetic turf field including landscape, irrigation, and soft pavements	2010	Department of the Navy 901 M. Street, S.E. Washington Navy Yard, Building 166 Washington, DC 20374-5095 (202) 685-8243 Attention: Ms. Carolyn Labanowski	DeLorenzo, Incorporated 1775 Hancock Street, Suite 150 San Diego, California 92110 (619) 295-5115 / (619) 297-2354 FAX Attention: Mr. Nicholas DeLorenzo, ASLA
Lions Field Redevelopment Fullerton, California	\$ 5,814,000	Prime	5	15 Acre municipal sports park with baseball, softball, football, fields all constructed using synthetic turf. Park also features parking, plazas restroom/concession building, and all related infrastructure	2010	City of Fullerton clo WEC Engineering 26672 Towne Center Drive Foothills Ranch, California (949) 600-5105 / (949) 600-5106 FAX Attention: Mr. Scott Walker	CTDLA 1903 St. Simons Place Fullerton, California 92831 (714) 773-0899 Attention: Mr. Craig Thomas Duncan
El Cerrito Sports Park Riverside County, California	\$ 11,870,000	Prime	6	25 Acre municipal sports park with baseball, softball, football, soccer, and multi-sport fields, basketball courts, playground, water play area restroom/concession building, parking, plazas, and all related infrastructure	2010	Economic Development Agency of Riverside County 3525 Fourteenth Street Riverside, California 92501 (951) 955-5737 / (951) 955-9177 FAX Attention: Ms. Delia Flores	BMLA, Inc. 310 North Joy Street Corona, California 92879 (951) 737-1124 / (951) 737-6551 FAX Attention: Mr. Baxter E. Miller
Torrance Unified School District Synthetic Turf Fields and Synthetic Track Torrance, California	\$ 8,700,000	Prime	4	Sub-grade preparation, sub-drains, aggregate base, irrigation systems,	2009	Torrance Unified School District 2334 Plaza del Amo Torrance, California 90501 (310) 972-6511 / (310) 972-6221 FAX Attention: Ms. Kathleen Hodge	Westberg + White, Inc. 14471 Chambers Road, Suite 210 Tustin, California 92780 (714) 508-1780 / (714) 508-1790 FAX Attention: Mr. Paul Dennis Westberg
Solano Community College Sports Fields Natural Turf Fields and Synthetic Track Sacramento, California	\$ 3,546,000	Sub	1	Construction of one natural turf football field including drainage, base, irrigation system. Also the construction of one natural turf multi-sport field and one synthetic all-weather running track	2009	Solano Community College District c/o Kitchell 4000 Suisun Valley Road Fairfield, California 94534 (707) 864-7189 Attention: Mr. Ron Richards	CMX Sports Engineers 7740 North 16th Street, Suite 100 Phoenix, Arizona 85020 (877) 567-1900 / (602) 567-1901 Attention: Mr. Jim Peryman

Project Name	Total Project Value	Project Role	No. of Fields	Self-Performed Work Scope	Year Built	Customer or Facility Owner	Designer
Durham Athletic Park - Renovation Durham, North Carolina	\$ 1,038,000	Sub	1	Construction of a vertically drained Minor League baseball field including excavation for drainlines, irrigation, sand-based rootzone mix, bermuda sod, warming track, infield mix and bull pen mounds.	2009	Skanska / City of Durham 2011 Fay Street Durham, NC 27704 (919) 560-4197 Attention: Mr. Danny King	Millennium Sports Technologies, Inc. 1893 West Kettle Avenue Littleton, Colorado 80120 (303) 730-1440 / (303) 730-2627 FAX Mr. Daniel Almond
Reno AAA Ballpark and Plaza Minor League Baseball Stadium Reno, Nevada	\$ 2,138,000	Sub	1	Construction of vertically-drained sand-based natural turf field, all skimmed surfaces, irrigation. Also the design of all site landscaping outside of the stadium and the installation of irrigation, planting, play equipment, site furnishings for the exterior space	2009	Devcon Construction 9476 Double R Boulevard, Suite B Reno, Nevada 89521 (775) 851-2255 / (775) 851-2265 FAX Mr. Doug Smith, Project Manager	HRP Studio / ValleyCrest Design Group 3242 Halladay, Suite 203 Santa Ana, California 92705 (714) 557-5852 / (714) 557-7621 FAX Mr. Glen Sharrar, Principal
Expo Center Multi-Use Fields Exposition Park Los Angeles, California DESIGN-BUILD	\$ 2,323,000	Prime Design-Build	2	Construction of a synthetic turf soccer field with surrounding park amenities. Engineering of a modular parkable surface to overlay the field for overflow parking from the adjacent L. A. Coliseum during sports events	2009	Friends of Expo P. O. Box 6097 Los Angeles, California 90734 (310) 832-1881 Mr. Steve Soboroff, President	HRP Studio / ValleyCrest Design Group 3242 Halladay, Suite 203 Santa Ana, California 92705 (714) 557-5852 / (714) 557-7621 FAX Mr. Kurt Buxton, Principal
Fountain Valley Recreation Complex Mile Square Park Fountain Valley, California	\$ 17,815,945	Prime	8	Renovation of existing fields and construction of six new baseball fields. Work also included parking plazas and walks, restroom and concession building, parking, and all related infrastructure.	2008	City of Fountain Valley 10200 Slater Avenue Fountain Valley, California 92708 (714) 593-4400 / (714) 593-4498 FAX Attention: Mr. Mark Lewis	The Willdan Company 2401 East Katella Avenue Anaheim, California 92806 (714) 940-6300 / (714) 940-4920 FAX Attention: Mr. Ken Thompson
Maricopa High School Phase 3 Field Synthetic turf field and synthetic track Maricopa, Arizona	\$ 661,861	Prime	1	Construction of sub-grade sub-drains, base course, & irrigation for one synthetic turf field. Work also included a new synthetic running track	2008	Maricopa Unified School District No. 20 45012 West Honeycutt Avenue Maricopa, Arizona 85239 (520) 568-5100 Attention: Mr. Paul Kasparian	Gilleland Bruebaker Architects 9017 North 57th Drive Glendale, Arizona 85302 (623) 937-5777 Attention: Mr. Donald Campbell
Harvard Westlake School Synthetic turf soccer fields complex Los Angeles, California	\$ 1,707,968	Sub	1	Construction of sub-grade sub-drains, base course, & irrigation for one synthetic turf soccer field	2008	Matt Construction 9814 Norwalk Boulevard, Suite 100 Santa Fe Springs, California 90670 (560) 903-2277 / (560) 903-2290 Attention: Faron van Dissal / Jim De Matte	Land Images Landscape Architects 501 North Larchmont Boulevard Los Angeles, California 90004 (323) 466-4707 / (323) 466-4797 Attention: Ms. Susan Powell

Project Name	Total Project Value	Project Role	No. of Fields	Self-Performed Work Scope	Year Built	Customer or Facility Owner	Designer
Simpson Athletic Fields Baylor University Waco, Texas	\$ 905,781	Sub	1	Construction of two vertically-drained, sand-based natural turf football practice fields	2008	H. C. Beck, Ltd. 1807 Ross Avenue, Suite 500 Dallas, Texas 75201 (214) 303-6650 / (214) 303-6750 FAX Mr. Steve Springer	Millennium Sports Technologies, Inc. 1893 West Kettle Avenue Littleton, Colorado 80120 (303) 730-1440 / (303) 730-2627 FAX Mr. Daniel Almond
Real Salt Lake Soccer Stadium & Plaza Real MLS Stadium Field Sandy, Utah	\$ 1,062,523	Sub	1	Construction of vertically-drained sand-based natural turf soccer stadium field and all irrigation and landscaping for area outside of the stadium	2008	Layton-Turner (JV) 9090 South Sandy Parkway Sandy, Utah 84070 (801) 568-9090 / (801) 569-5450 FAX Mr. Brian Saller, Project Engineer	Millennium Sports Technologies, Inc. 1893 West Kettle Avenue Littleton, Colorado 80120 (303) 730-1440 / (303) 730-2627 FAX Mr. Daniel Almond
Dick's Sporting Goods Park Colorado Rapids MLS Team Commerce City, Colorado	\$ 2,968,886	Sub	1	Construction of vertically drained sand-based natural turf field and all common area landscaping and irrigation around stadium.	2007	Turner Construction Sport 1873 S. Bellaire Street, Suite 1200 Denver, Colorado 80222 (303) 753-9600 / (303) 753-9700 FAX Mr. Gene Future	Millennium Sports Technologies, Inc. 1893 West Kettle Avenue Littleton, Colorado 80120 (303) 730-1440 / (303) 730-2627 FAX Mr. Daniel Almond
Dougherty Valley High School Natural turf baseball fields Synthetic turf soccer fields San Ramon, California	\$ 10,044,480	Prime	1	Construction of sub-grade sub-drains, base course, & irrigation for three baseball and one synthetic turf football field plus all irrigation of surrounding school grounds.	2007	San Ramon Valley Unified School District 699 Old Orchard Drive Danville, California 94526 (925) 552-2967 / (925) 838-3147 FAX Attention: Mr. Robbie Lyng	Akol and Yoshii Architect 1407 Oakland Boulevard Walnut Creek, California 94596 (925) 934-5522 / (925) 934-6427 FAX Attention: Ms. Stacey Durocher
Simi Valley High School Stadium Synthetic turf field and Synthetic Track Simi, California 1 Synthetic Turf Football Field	\$ 1,850,000	Prime	1	Demolition, grading and drainage, concrete and asphalt paving, concrete curbs, synthetic track and synthetic running track	2007	Simi Valley Unified School District 875 East Cochran Street Simi Valley, California 93065 (805) 306-4690 / (805) 520-6504 Attention: Mr. Lowell Schultze	HMC Architecture 766 East Colorado Boulevard, Suite 200 Pasadena, California 91101 (626) 535-0500 / (626) 535-0510 FAX Attention: Mr. Hazim Rabadi
Prairie Gateway Soccer Complex Natural and Synthetic turf fields Commerce City, Colorado	\$ 7,981,036	Sub	2	Construction of sub-grade sub-drains, base course, & irrigation for twenty-two natural turf and two synthetic turf soccer fields. Irrigation of surrounding park and wetlands restoration	2007	KSE Enterprises 1000 Chopper Circle Denver, Colorado 80204 (303) 405-8552 / (303) 893-8022 FAX Mr. Mike Rock	Norris Design Company 1101 Bannock Street Denver, Colorado 80204 (303) 892-1166 / (303) 892-1186 FAX Mr. John Norris
Section 30 Soccer Complex Natural and Synthetic turf fields Broomfield, Colorado	\$ 1,015,814	Prime	2	Construction of sub-grade sub-drains, base course, & irrigation for two synthetic turf soccer fields. Work included surrounding irrigation and planting	2007	KSE Enterprises 1000 Chopper Circle Denver, Colorado 80204 (303) 405-8552 / (303) 893-8022 FAX Mr. Mike Rock	Norris Design Company 1101 Bannock Street Denver, Colorado 80204 (303) 892-1166 / (303) 892-1186 FAX Mr. John Norris

Project Name	Total Project Value	Project Role	No. of Fields	Self-Performed Work Scope	Year Built	Customer or Facility Owner	Designer
Long Lake Park Sports Fields, Phase III Synthetic turf soccer field Arvada, Colorado	\$ 711,865	Prime	2	Construction of sub-grade sub-drains, base course, & irrigation for synthetic turf field	2007	City of Arvada 8101 Ralston Road Arvada, Colorado 80002 (720) 898-7391 / (720) 898-7401 FAX Attention: Mr. Jeff Simmons	City of Arvada Park & Urban Design 8101 Ralston Road Arvada, Colorado 80002 (720) 898-7400 / (720) 898-7401 FAX Attention: Mr. Jeff Simmons
Buccaneers Practice Facility Tampa Bay Buccaneers NFL Team Tampa Bay, Florida	\$ 1,005,867	Sub	3	Sub-grade, sub-drains, irrigation, root zone mix, laser grading, natural and turf fields, and grow-in maintenance	2006	Hunt Construction Group, Inc., 7650 Courtney Campbell Causeway, Suite 1150 Tampa, Florida 33607 (813) 879-0450 / (813) 879-7047 FAX Mr. Stan Shaw	ValleyCrest Landscape Development 5330 Country Road No. 579 Seffner, Florida 33584 (813) 628-8116 Mr. Andy Johnson
Virginia Military Academy Synthetic turf football practice facility Lexington, VA	\$ 1,261,038	Sub	1	Construction of synthetic practice football field including drainage, base, irrigation system.	2006	Branch and Associates (Construction Mgr.) 3902 Franklin Road Roanoke, Virginia 24014 (540) 989-5215 / (540) 989-0883 FAX Attention: Ms. Heather Bowman	Sheretz Franklin Crawford Shaffner 305 South Jefferson Street Roanoke, Virginia 24450 (540) 344-6664 / (540) 343-6925 FAX Attention: Mr. Damm Huff
John Anson Ford Sports Complex Two synthetic turf soccer fields* Bell Gardens, California *Fields are part of the Chivas USA Academy Fields	\$ 7,165,994	GC	2	Total park development including baseball park, synthetic turf soccer fields and all support amenities	2006	City of Bell Gardens 8327 S. Garfield Ave Bell Gardens, California 90201 (562) 776-5342 Attention: Mr. John Oskoui	David Volz Design 17050 Bushard St Ste 300 Fountain Valley, California 92708 (714) 593-3300 / (714) 593-3330 FAX Attention: Mr. David Volz
Reach 11 Soccer Complex - Phase 1 & 2 1 Synthetic turf soccer field* 9 Natural turf soccer fields <i>*ValleyCrest Scope limited to sub-surface</i>	\$ 3,117,478	Prime	1	Construction of sub-grade sub-drains, base course, & irrigation for synthetic turf. Turnkey construction of 9 natural turf fields	2006	D. L. Withers Construction, Inc. 3220 East Harbour Drive Phoenix, Arizona 85034 (602) 438-9500 / (602) 438-9600 FAX Attention: Mr. Mike Bornhoff	Engineering & Environmental Consultants 7878 North 16th Street, Suite 140 Phoenix, Arizona 85020 (602) 248-7702 / (602) 248-7851 FAX Attention: Mr. Mark Gavan
Riverwood High School Track Atlanta, Georgia	\$ 252,900	Sub	1	Demolition, grading and drainage, concrete and asphalt paving, concrete curbs, synthetic track and synthetic turf field	2006	Balfour Beatty Construction, LLC 600 Galleria Parkway, Suite 1800 Atlanta, Georgia 30339 (678) 921-6800 / (678) 921-6801 FAX Attention: Mr. Mel Mauro	Passantino and Bavier, Inc. 2233 Lake Park Drive Smyrna, Georgia 30080 (404) 437-2680 Attention: Mr. Greg Sherley
Buncombe County Field Replacement Multiple school locations Burnsville, North Carolina	\$ 1,653,000	Sub	7	Demolition, grading and drainage, aggregate base layer and synthetic turf fields for seven different high schools.	2006	Young and McQueen Grading Co. 25 Crest View Road Burnsville, North Carolina 29714 (828) 682-7714 / (828) 682-4145 FAX Attention: Mr. Sam Young	Architectural Design Studio PA 90 Church Street Asheville, North Carolina 28801 (828) 252-0355 / (828) 252-4059 FAX Attention: Mr. Tad Clarkston
Golden Valley High School Santa Clarita, California	\$ 8,400,000	Sub	1	Demolition, grading and drainage, concrete and asphalt paving, concrete curbs, synthetic track and synthetic turf field	2006	William S. Hart Union High School Dist. 21515 Center Pointe Parkway Santa Clarita, California 91350 (661) 259-0033 / (661) Attention: Mr. Rony S. Livingston	Oasis Landscape Architecture/Planning 3427 Miguellito Court San Luis Obispo, California 93401 (805) 541-4590 / (805) 546-0525 FAX Attention: Mr. Michael Cripe

Project Name	Total Project Value	Project Role	No. of Fields	Self-Performed Work Scope	Year Built	Customer or Facility Owner	Designer
West Ranch High School Santa Clarita, California	\$ 4,724,456	Sub	1	Demolition, grading and drainage, concrete and asphalt paving, concrete curbs, synthetic track and synthetic turf field	2006	William S. Hart Union High School Dist. 21515 Center Pointe Parkway Santa Clarita, California 91350 (661) 259-0033 / (661) Attention: Mr. Rory S. Livingston	Oasis Landscape Architecture/Planning 3427 Miguelito Court San Luis Obispo, California 93401 (805) 541-4590 / (805) 546-0525 FAX Attention: Mr. Michael Cripe
Tassajara Soccer Fields Danville, California	\$ 1,094,141	Prime	2	Construction of sub-grade sub-drains, base course, & irrigation for synthetic turf. Turnkey construction of 9 natural turf fields	2006	Shapell Homes 100 North Milpitas Boulevard Milpitas, California 95035 (408) 946-1550 / (408) 263-0523 FAX Attention: Jim Gold	Nuvix Landscape Architecture and Planning 5 Crow Canyon Court, Suite 110 San Ramon, California 94583 (925-820-2711 / (925) 820-2772 FAX Attention: Ms. Leslee A. Temple, ASLA
Kenilworth Sports Complex Natural turf baseball and soccer fields Coolidge, Arizona	\$ 3,500,000	Prime	3	Design-build deliver of a 20 acre community park with restrooms, concession building, sports fields lighting, parking, and playground area and all related infrastructure and landscaping.	2006	City of Coolidge 660 South Main Street Coolidge, Arizona 85338 (520) 723-6037 / (520) 723-6021 FAX Ms. Nicole Zimmerman	Logan Simpson Design 51 West Third Street, Suite 450 Tempe, Arizona 85281 (480) 967-1343 / (480) 966-9232 FAX Mr. Steve Lohide
Cardinals Stadium Field The first fully-retractable field in U.S. Glendale, Arizona	\$ 560,000	Sub	1	Construction of vertically drained sand-based natural turf field on structural steel moving platform that can be moved as one unit	2006	Hunt Construction Group, Inc., 426 North 44th Street, Suite 410 Phoenix, Arizona 85008 (602) 225-9500 / (602) 231-8590 FAX Mr. Tad Baker	CMX Sports Engineers 7740 North 16th Street, Suite 100 Phoenix, Arizona 85020 (877) 567-1900 / (602) 567-1901 Mr. Mike Lloyd
Virginia Military Academy Memorial Field Renovation & Soccer Field Lexington, VA	\$ 1,261,038	Sub	2	Sub-grade prep, vertically drained natural bermuda turf football field repair and renovation. Irrigation and bermuda soccer field also.	2006	Branch and Associates (Construction Mgr.) 3902 Franklin Road Roanoke, Virginia 24014 (540) 989-5215 / (540) 989-0883 FAX Attention: Ms. Heather Bowman	Sheretz Franklin Crawford Shaffner 305 South Jefferson Street Roanoke, Virginia 24450 (540) 344-6664 / (540) 343-6925 FAX Attention: Mr. Damm Huff
Tempe Diablo Stadium Renovation Stadium and practice fields for Tempe, Arizona	\$ 1,887,610	Sub	3	Sub-grade, sub-drains, irrigation, root zone mix, laser grading, sod, base line and warming tracks, grow-in maintenance	2006	Moline Construction 118 West Hatcher Phoenix, Arizona 85021 (602) 674-3144 / (602) 674-3125 Attention: Mr. Jerry Huston	DLR Group 6225 North 24th Street Phoenix, Arizona 85016 (602) 381-8580 / (602) 956-8358 FAX Attention: Mr. George Rice
Dodger Stadium Field Renovation Los Angeles, California	\$ 152,637	Sub	1	Remove existing turf field, Re-grade and adjust warming track dimensions to fit new dugouts and seating areas Renovate irrigation system	2005	Gordon and Williams 2 Faraday Irvine California 92610 (949) 588-2855 / (949) 588-2877 FAX Mr. Tom Beacom	ValleyCrest Landscape Development 24151 Ventura Boulevard Calabasas, California 91302 (818) 223-8500 / (818) 225-7408 Mr. Richard Bruttig

Project Name	Total Project Value	Project Role	No. of Fields	Self-Performed Work Scope	Year Built	Customer or Facility Owner	Designer
The Westminster School Football, Soccer, and Baseball Stadium Field Renovations Project in Progress	\$ 336,262	GC	2	Demolition, undercut field, replace existing field with sand rootzone mix, new irrigation and sod	2005	Athletic Facilities Consulting 5001 Lake Forest Drive, SE Conyers Georgia 30094 (770) 760-7988 / (770) 760-7988 FAX Mr. Tom Tupps	Athletic Facilities Consulting 5001 Lake Forest Drive, SE Conyers Georgia 30094 (770) 760-7988 / (770) 760-7988 FAX Mr. Tom Tupps
Artificial Turf Sports Field Athletic Field	\$ 1,450,600	GC	1	Demolition, grading and drainage, concrete and asphalt paving, concrete curbs, synthetic turf field	2005	City of Glendale 613 East Broadway, Suite 120 Glendale, California 91206 (818)-548-3796 / (818) 548-3789 FAX Attention: Mr. Shanan Begoumian	CMX Sports Engineers 7740 North 16th Street, Suite 100 Phoenix, Arizona 85020 (877) 567-1900 / (602) 567-1901 Attention: Mr. Michael Lloyd
Jacksonville State University Paul Snow Stadium - Field Renovation	\$ 361,375	Sub	1	Demolition, grading, and drainage, concrete, sub-surface base for synthetic field	2005	Pro Grass, LLC 960 Penn Avenue, Suite 810 Pittsburg, Pennsylvania 15222 (412) 434-6003 / (412) 391-2270 FAX Mr. Mark Wakeman	Holcombe, Norton, & Pritchett 1914 28th Avenue South Homewood, Alabama 35209 (205) 870-9936 / (205) 871-8974 FAX Mr. Ed Norton
West Los Angeles College Synthetic Turf Athletic (In-Fill) All Weather Synthetic Mondo Track	\$ 2,915,000	GC	1	Demolition, grading and drainage, concrete and asphalt paving, concrete curbs, synthetic track and synthetic turf field	2005	Los Angeles Community College Dist. c/o Turner Construction (CM) 9000 Overland Avenue, Building A15 Culver City, California 90230 (310) 202-2575 / (310) 202-2576 FAX Ms. Amanda Mason	Ah Be Landscape Architects 8729 Washington Boulevard Culver City, California 90323 (310) 838-0448 / (310) 204-2664 FAX Attention: Evan Mather
Bell Gardens High School Athletic Field Athletic Field	\$ 2,028,000	GC	1	Demolition, grading and drainage, concrete and asphalt paving, concrete curbs, synthetic track and synthetic turf field	2005	Montebello Unified School District 500 North Hendricks Street Montebello, California 90640 (323) 887-7900 / (323) 887-3048 FAX Attention: Ms. Pamela T. Johnson	HMC Architecture 766 East Colorado Boulevard, Suite 200 Pasadena, California 91101 (626) 535-0500 / (626) 535-0510 FAX Attention: Mats Peika
Arcadia High School Synthetic Turf Athletic Field (In-Fill) All Weather Synthetic Track	\$ 1,045,000	GC	1	Demolition, grading and drainage, concrete and asphalt paving, concrete curbs, synthetic track and synthetic turf field	2005	Arcadia Unified School District 234 Campus Drive Arcadia, California 91007 (626) 821-6631 / (626) 574-3802 FAX Mr. Jerry Thompson	Ah Be Landscape Architects 8729 Washington Boulevard Culver City, California 90323 (310) 838-0448 / (310) 204-2664 FAX Attention: David Briley
Sir Francis Drake High School Synthetic Turf Athletic Field (In-Fill) All Weather Synthetic Track San Enselmo, California	\$ 2,809,095	GC	1	Demolition, grading and drainage, concrete and asphalt paving, concrete curbs, synthetic track and synthetic turf field	2004	Tamalpais Union High School District 1327 Sir Francis Drake Boulevard San Enselmo, California 94960 (415) 924-2683 / (415) 924-7419 FAX Ms. Erica Moreno	Carducci and Associates 555 Beach Street, 4th Floor San Francisco, California 94133 (415) 674-0990 / (415) 674-0999

Project Name	Total Project Value	Project Role	No. of Fields	Self-Performed Work Scope	Year Built	Customer or Facility Owner	Designer
Green Bay Packers Practice Facility Phase 1 and 2 NFL Practice Facility Green Bay, Wisconsin	\$ 1,929,000	GC	2	Sub-grade, sub-drains, irrigation, root zone mix, laser grading, sod, goal posts, wall pads, and grow-in maintenance	2004	Green Bay Packers 1265 Lombardi Avenue Green Bay, Wisconsin 54301 (920) 569-7301 Mr. Allen Johnson	D. A. Hogan and Associates 1708 Bellevue Avenue Seattle, Washington 98122 (206) 285-0400 / (206) 285-0480 FAX Mr. Richard McDonald
Mountain View / Los Altos (2 Sites) Synthetic Turf Athletic Field (In-Fill) All Weather Synthetic Track 1 = Mountain View High School 2 = Los Altos High School	\$ 4,665,300	GC	3	Demolition, grading and drainage, concrete and asphalt paving, concrete curbs, synthetic track and synthetic turf field	2004	Mountain View / Los Altos H. S. Dist. 1299 Bryant Avenue Mountain View, California 94040 (650) 940-4650 / (650) 961-1346 FAX Mr. Joe White, District Manager	Beals Sports Collaborative 2 Market Street, 5th Floor San Jose, California 95113 (408) 287-3030 / Mr. Devin Conway
Boulder Valley Schools Track and Field Renovations Three High School Sites Boulder, Colorado	\$ 2,823,012	GC	3	Removal and replacement of existing natural turf fields with synthetic turf and installation of new amenities	2004	Boulder Valley Schools, Public RE-2 6500 Arapahoe Boulder, Colorado 80301 (303) 447-5157 / (303) 447-5160 FAX Mr. Lou Novak	Davis Partners 2301 Blake Street Boulder, Colorado 80205 (303) 861-8555 / (303) 861-3027 FAX Mr. David Land
Regis Jesuit High School High School Synthetic Turf Field Aurora, Colorado	\$ 862,467	GC	1	Removal and replacement of existing natural turf fields with synthetic turf	2004	Regis Jesuit High School 16300 East Weaver Place Aurora, Colorado 80016 (303) 269-8031 / (303) 766-2240 FAX Mr. Rick Sullivan	Millennium Sports Technologies, Inc. 1893 West Kettle Avenue Littleton, Colorado 80120 (303) 730-1440 / (303) 730-2627 FAX Mr. Daniel Almond
Boston College Football Field Athletic Field Irrigation System Chestnut Hill, Massachusetts	\$ 80,000	Sub	1	Installed new irrigation system for college football field	2004	Boston College 140 Commonwealth Avenue Chestnut Hill, Massachusetts 02467 Not Applicable Attention: N/A work performed as a sub.	Geller DeVelis, Inc., (Now Stantec) 141 Portland Street Boston, Massachusetts 02114 (617) 523-8103 / (617) 523-4333 FAX Ms. Robert Coming
Bell Field at Occidental College Athletic Field and Parking Lot Los Angeles, California	\$ 766,230	GC	1	Demolition, grading and drainage, concrete and asphalt paving, concrete curbs, natural turf field.	2004	Occidental College 1600 Campus Road Los Angeles, California 90041 (323) 259-2853 / (323) 341-4978 FAX Mr. John Morl	Carter, Romanek Landscape Architects 540 Palisades Drive Pacific Palisades, California 90272 (310) 230-9691 / (310) 230-9231 FAX Ms. Gillian Blessley
Mt. San Antonio College Athletic Fields Community College Sports Field Walnut, California	\$ 1,019,341	Sub	1	Field sub-grade, vertically drained sand-based natural turf field	2004	W. B. Allen Construction, Inc., 6191 Junupa Aveue Riverside, California 92504 (909) 688-3221 / (909) 688-7063 FAX Mr. Chns Ivany	R. J. M. Design Group 27285 Las Ramblas, Suite 250 Mission Viejo, California 92691 (949) 493-2600 / (949) 493-2690 FAX Mr. Larry Ryan
Bill Barber Marine Park - Phase II Regional Sports Park Irvine, California <i>Note ValleyCrest also constructed Phase One of this park</i>	\$ 5,795,000	GC	2	Fine grade, landscape drains, sub-drains, concrete, irrigation, planting, site furniture, maintenance	2004	City of Irvine 1 Civic Center Plaza Irvine CA 92623 (949) 724-6000 / (949) Ms. Christina Lo	R. J. M. Design Group 27285 Las Ramblas, Suite 250 Mission Viejo, California 92691 (949) 493-2600 / (949) 493-2690 FAX Mr. Larry Ryan



ValleyCrest
Landscape Development
Celebrating 60 Years
1949 ~ 2009

10855 Business Center Drive, Suite C
Cypress, California 90630

****Sealed Bid****
RANCHO JURUPA REGIONAL SPORTS COMPLEX

REDEVELOPMENT AGENCY FOR THE COUNTY OF ORANGE
County Administrative Center
4080 Lemon Street
Riverside, CA. 92501

Landscape Development Landscape Maintenance Golf Course Maintenance Tree Com

SEALED BID RECEIVED
CLERK OF THE BOARD OF SUPERVISORS

RECEIVED RIVERSIDE COUNTY
CLERK / BOARD OF SUPERVISORS
2010 OCT 25 PM 2:20

CONTRACTOR'S PROPOSAL
Rancho Jurupa Regional Sports Complex

TO THE GOVERNING BOARD OF THE REDEVELOPMENT AGENCY FOR THE COUNTY OF RIVERSIDE:

Date: 10/25/10

Bidder: Armand Gonzales Inc. dba Gonzales Construction

The undersigned, having carefully examined the proposed site and the Plans and Specifications, the Notice Inviting Bids, the Instructions to Bidders, the Agreement Form, the Bond Forms, the General Conditions for the Construction of the Rancho Jurupa Regional Sports Complex, hereby proposes and agrees to furnish all tools, equipment, services, apparatus, facilities, transportation, labor and materials necessary to complete the work in strict conformity with the Plans and Specifications, including all work specified in Addenda numbered and dated:

Addendum No. 1 Date 10/7/10
Addendum No. 2 Date 10/13/10
Addendum No. 3 Date 10/15/10
Addendum No. 4 Date 10/20/10
Addendum No. 5 Date 10/22/10
Addendum No. _____ Date _____
Addendum No. _____ Date _____

BASE BID

Clear and Grub/Demolition:	\$ _____
Grading and Drainage:	\$ <u>1,486,270</u>
Water and Sewer:	\$ <u>585,648</u>
Electrical:	\$ <u>1,151,500</u>
Site Construction:	\$ <u>6,078,419</u>
Irrigation:	\$ _____
Planting:	\$ <u>1,124,297</u>

For the total Base Bid Ten million Four hundred twenty-six thousand dollars
(in words) one hundred thirty-four
(\$ 10,426,134)

including all applicable taxes, permits, licenses, **AND Course of Construction Insurance.**

ALTERNATE BID ITEMS

(Add or Deduct state which)

1. Alternate Bid Synthetic Turf "FieldTurf Prestige XM50"
(refer to specifications section 02890.05 A)

\$ 1,601,876 Add

2. Alternate Bid Synthetic Turf "Mondo Green Ecofill MF4563"
(refer to specifications section 02890.05 B)

\$ 2,239,200 Add

3. Alternate Bid Synthetic Turf "Sprinturf Ultrablade DF"
(refer to specifications section 02890.05 C)

\$ 1,214,668 Add

4. Alternate Bid Football Field
Item includes football field striping, combination football/soccer goals and steel posts and netting. Original soccer goals shall be included in the base bid.

\$ 7,000 Add

5. Alternate Bid _____
(as listed by contractor)

\$ _____

6. Alternate Bid _____
(as listed by contractor)

\$ _____

7. Alternate Bid _____
(as listed by contractor)

\$ _____

8. Alternate Bid _____
(as listed by contractor)

\$ _____

9. Alternate Bid _____
(as listed by contractor)

\$ _____

10. Alternate Bid _____
(as listed by contractor)

\$ _____

And,
Cost of Contractor's Course of Construction Insurance Seventyone Thousand dollars (\$ 17,000) and deductible \$ 5,000.

Bids must be submitted on all items (except Alternate Bid items 5-10 if not needed by contractor). Failure to bid on all items may result in the bid being rejected as non-responsive. The basis for award will be the qualified bidder with the lowest total of the Base Bid WITH COURSE OF CONSTRUCTION INSURANCE. Alternates may be awarded in any order after determination of the lowest responsible and responsive bidder.

5. Contractor shall note the requirement of providing for turnover to the County a synthetic turf sweeper and groomer as part of the base bid cost as noted on page 9 of specification section 02890.
6. Contractor shall note that the drainline shown on sheets C5 and C9 shall NOT be installed under the concrete paving as shown. Drainline shall be installed as shown on sheet TD-1.
7. The **County will provide** all site survey services. Section 8.9.1 under "LAYOUT OF WORK" shall be modified accordingly.
8. The attached "Contractor's Proposal" shall be used in place of the one in the original bid specifications.

DATED: October 7, 2010

10/14/2010

Date Received by Bidder

By: _____
Jason Plotkin, Project Manager

By: _____
Bidder's Signature

Armand Gonzales, President

Typed or Printed Name



ECONOMIC DEVELOPMENT AGENCY – COUNTY OF RIVERSIDE

ADDENDUM NO. 002

TO BIDDING DOCUMENTS, CONTRACT, BASIC SPECIFICATIONS, AND SPECIAL REQUIREMENTS
FOR
RANCHO JURUPA REGIONAL SPORTS COMPLEX

Bidders are advised that the Contract Documents for the above referenced contract are hereby amended in the following manner and in the following manner only:

A. GENERAL

1. All provisions of this Addendum No. 002 are hereby incorporated into the contract documents, and bidders shall account for all provisions pursuant to this Addendum No. 002 in submitting their bid proposals. Each bidder shall include a dated and signed copy of this Addendum No. 002 with his sealed bid proposal.
2. The following Addendum No. 002 contains the job walk sign-in sheets, agenda, and answers to questions asked at the job walk.

DATED: October 13, 2010

By: _____
Jason Plotkin, Project Manager

October 14, 2010

Date Received by Bidder

By: _____
Bidder's Signature

Armand Gonzales, President

Typed or Printed Name

5. Replace specification Section 02890 – Synthetic Turf with the attached file:
"02890 - SYNTHETIC TURF SYSTEM (rev for Addendum #3).pdf"

Note change to 02890.06 item 2:

2. In the event that the Prime Contractor does not meet these requirements, a sub-contractor may be listed that does meet the requirements specified in item 1 above. The Prime Contractor shall provide evidence of experience by the listed sub-contractor in preparing drainage base systems for synthetic turf and the sub-contractor must have installed a minimum of 10 sub-grade drainage base systems for synthetic turf playing fields in the past 3 years in California.

6. Replace the Contractor's Proposal with the attached file:
"RJSC Contractor's Proposal - Addendum #3 (10-15-10).pdf"

DATED: October 15, 2010

By: _____
Jason Plotkin, Project Manager

10/15/10
Date Received by Bidder

By: _____
Bidder's Signature

Armand Gonzales, President
Typed or Printed Name

- 17. The exterior of the trash enclosure walls shall have a stone veneer wainscot to match the electrical enclosure on detail "E" sheet CD-2.
- 18. Refer to Stone Veneer Column detail included in Addendum #4 for detail on stone veneer columns at the shade structure posts.

DATED: October 20, 2010

By: _____
Jason Plotkin, Project Manager

October 20, 2010

Date Received by Bidder

By: _____
Bidder's Signature

Armand Gonzales, President

Typed or Printed Name

DATED: October 22, 2010

10/22/10

Date Received by Bidder

By: 
Jason Plotkin, Project Manager

By: 
Bidder's Signature

Armand Gonzales, President

Typed or Printed Name

DESIGNATION OF SUBCONTRACTORS

In compliance with Section 4104 of the Public Contract Code the undersigned submits the following complete list of each Subcontractor who will perform work or labor or render service in or about the construction/installation in an amount in excess of 1/100th 1% of said total bid.

<u>PORTION OF THE WORK</u>	<u>SUBCONTRACTOR</u>	<u>ADDRESS</u>
SITE WORK	VARMER CONST.	RIVERSIDE
PAVE SHADE	PARK SPECIALTIES	FALLBROOK
SITE UTILITIES	PST PLUMBING	SANTA FE SPRINGS
PAVEMENT	PAVEWEST	LA HABRA
PAVEMENT MARKING	A good sign	MISSION Viejo
CONCRETE PAVERS	Alpha & Omega PAVERS	MORENO Valley
LANDSCAPE	ADVANCED LandscAPE	WOODLAND Hills
MASONRY	J GINGER MASONRY	RIVERSIDE
METAL Fabrication	FENCE CORP.	RIVERSIDE
PAINTING	BITHELL	COVINA
ELECTRICAL	RAM ELECT.	LAKE FOREST
TURF	SPRINT TURF	INGERSOLL, PA
DRAINAGE	PARKWEST SPORTS	ORANGE
SITE UTILITIES	J'S PIPING	ONTARIO
PRE-FAB STRUCTURE RESTROOM	Public RESTROOMS	RENO, N.Y.
TURF	A TURF	williamsville, N.Y.

AWARD OF CONTRACT

The undersigned fully understands that a Contract is formed upon the acceptance of this Proposal by the Owner and the undersigned further agrees that upon request he will promptly execute and deliver to Owner a written memorial of the Contract together with the required Payment and Performance Bonds and proof of insurance.

BID GUARANTEE

The enclosed certified or cashier's check or bidder's bond on approved form, made payable to the Owner in the amount of ten percent of the total bid submitted herewith, is hereby given as a guarantee that the bidder will execute and deliver the above mentioned written memorial and required bonds and insurance if awarded the contract, and in the event that the undersigned fails or refuses to execute and deliver said documents, such check or bond is to be charged with the costs of the damages experienced by the Owner as a result of such failure or refusal, including but not limited to publication costs, the difference in money between the amount of the bid of the said principal and the amount for which obligee may legally contract with another party to perform the said work if such amount be in excess of the former, building lease or rental costs, transportation costs and additional salary costs that result from the delay due to the principal's default on the awarded contract. In no event, however, shall the Surety's liability exceed the penal sum hereof.

Name of Bidder: Armand Gonzales Inc. dba Gonzales Construction

Type of Organization: Corporation

Signed By: Armand Gonzales

Title of Signer: President

Address of Bidder: 19531 Ventura Blvd., 2nd Floor
Tarzana, CA 91356

Affix Seal
If
Corporation

Telephone No.: 818-758-2490

Contractor's License No.: 510565

Classification: A, B, C-36 Expiration Date: 5/31/2011

LICENSURE STATEMENTS ARE MADE UNDER PENALTY OF PERJURY

If bidder is a corporation, and signer is not President or Secretary, attach a certified copy of By-Laws or resolution authorizing execution. If bidder is a corporation, affix corporate seal. If signer is an agent, attach Power of Attorney. If bidder is not an individual, list names of other persons authorized to bind the organization.

Bid Bond

KNOWN TO ALL MEN BY THESE PRESENTS, that we, the undersigned Armand Gonzales, Inc.
dba Gonzales Construction, as Principal; and International Fidelity Insurance Company as Surety, are
hereby held and firmly bound unto the Redevelopment Agency for the County of Riverside, hereinafter called
the "Owner", in the sum of (10%) Ten Percent of Attached Bid Amount Dollars (\$ 10.0% of Bid) for the
payment of such sum, well and truly to be made, do hereby jointly and severally bind ourselves, our heirs,
executors, administrators, successors and assigns.

WHEREAS, the said Principal is herewith submitting its Proposal for the
Rancho Jurupa Regional Sports Complex

THE CONDITION OF THE ABOVE OBLIGATION IS SUCH, that if the aforesaid Principal shall be awarded
the Contract upon said Proposal and shall, within the required number of days after the notice of such award,
execute a written memorial of the awarded Contract and submit the required Labor and Material Payment and
faithful Performance Bond and proof of insurance, then this obligation shall be null and void; and in the event
that the Principal fails and/or refuses to execute and deliver said documents this Bond will be charged with the
costs of the damages experienced by the Owner as a result of such refusal, including but not limited to,
publication cost, the difference in money between the amount of the bid of the said Principal and the amount
for which the obligee may legally contract with another party to perform the said work if such amount be in
excess of the former; building lease or rental costs, transportation cost, and additional salary costs that result
from the delay due to the Principal's default on the awarded Contract. In no event however, shall the Surety's
liability exceed the penal sum hereof.

The Surety, for value received, hereby stipulates and agrees that the obligations of said Surety and its bond
shall be in no way impaired or affected by any extension of the time within which the Owner may accept such
bid; and said Surety does hereby waive notice of any such extension.

IN WITNESS WHEREOF, the above bounded parties have executed this instrument under their separate
seals this 20th day of October, 2010, the name and corporate seal of each corporate party
being hereto affixed and those present duly signed by its undersigned representative, pursuant to authority of
its governing body.

Armand Gonzales, Inc. dba Gonzales Construction
(Firm Name - Principal)

19531 Ventura Blvd., 2nd Floor, Tarzana, CA 91356
(Business Address)

By Armand Gonzales
(Original Signature)

President
(Title)

International Fidelity Insurance Company
(Corporation Name - Surety)

One Newark Center, Newark, NJ 07102
(Business Address)

By Stephanie Pham
(Original Signature) Stephanie Pham, Attorney-in-Fact

Affix Seal
If
Corporation

Affix
Corporate
Seal

CALIFORNIA ALL-PURPOSE ACKNOWLEDGMENT

STATE OF CALIFORNIA

County of Orange }

On 10/20/10
Date

before me, Irene Luong, Notary Public
Here Insert Name and Title of the Officer

personally appeared Stephanie Pham
Name(s) of Signer(s)



Place Notary Seal Above

who proved to me on the basis of satisfactory evidence to be the person(s) whose name(s) is/are subscribed to the within instrument and acknowledged to me that he/she/they executed the same in his/her/their authorized capacity(ies), and that by his/her/their signature(s) on the instrument the person(s), or the entity upon behalf of which the person(s) acted, executed the instrument.

I certify under PENALTY OF PERJURY under the laws of the State of California that the foregoing paragraph is true and correct.

Witness my hand and official seal.

Signature Irene Luong
Signature of Notary Public

OPTIONAL

Though the information below is not required by law, it may prove valuable to persons relying on the document and could prevent fraudulent removal and reattachment of this form to another document.

Description of Attached Document

Title or Type of Document: _____

Document Date: _____ Number of Pages: _____

Signer(s) Other Than Named Above: _____

Capacity(ies) Claimed by Signer(s)

Signer's Name: Stephanie Pham

- Individual
- Corporate Officer — Title(s): _____
- Partner — Limited General
- Attorney in Fact
- Trustee
- Guardian or Conservator
- Other: _____

**RIGHT THUMBPRINT
OF SIGNER**

Top of thumb here

Signer Is Representing: _____

Signer's Name: _____

- Individual
- Corporate Officer — Title(s): _____
- Partner — Limited General
- Attorney in Fact
- Trustee
- Guardian or Conservator
- Other: _____

**RIGHT THUMBPRINT
OF SIGNER**

Top of thumb here

Signer Is Representing: _____

POWER OF ATTORNEY INTERNATIONAL FIDELITY INSURANCE COMPANY

HOME OFFICE: ONE NEWARK CENTER, 20TH FLOOR
NEWARK, NEW JERSEY 07102-5207

KNOW ALL MEN BY THESE PRESENTS: That INTERNATIONAL FIDELITY INSURANCE COMPANY, a corporation organized and existing laws of the State of New Jersey, and having its principal office in the City of Newark, New Jersey, does hereby constitute and appoint

STEPHANIE PHAM, MARK RICHARDSON, ERIC LOWEY, SHAWN BLUME

Costa Mesa, CA.

its true and lawful attorney(s)-in-fact to execute, seal and deliver for and on its behalf as surety, any and all bonds and undertakings, contracts of indemnity and other writings obligatory in the nature thereof, which are or may be allowed, required or permitted by law, statute, rule, regulation, contract or otherwise, and the execution of such instrument(s) in pursuance of these presents, shall be as binding upon the said INTERNATIONAL FIDELITY INSURANCE COMPANY, as fully and amply, to all intents and purposes, as if the same had been duly executed and acknowledged by its regularly elected officers at its principal office.

This Power of Attorney is executed, and may be revoked, pursuant to and by authority of Article 3-Section 3, of the By-Laws adopted by the Board of Directors of INTERNATIONAL FIDELITY INSURANCE COMPANY at a meeting called and held on the 7th day of February, 1974.

The President or any Vice President, Executive Vice President, Secretary or Assistant Secretary, shall have power and authority

- (1) To appoint Attorneys-in-fact, and to authorize them to execute on behalf of the Company, and attach the Seal of the Company thereto, bonds and undertakings, contracts of indemnity and other writings obligatory in the nature thereof and,
- (2) To remove, at any time, any such attorney-in-fact and revoke the authority given.

Further, this Power of Attorney is signed and sealed by facsimile pursuant to resolution of the Board of Directors of said Company adopted at a meeting duly called and held on the 29th day of April, 1982 of which the following is a true excerpt:

Now therefore the signatures of such officers and the seal of the Company may be affixed to any such power of attorney or any certificate relating thereto by facsimile, and any such power of attorney or certificate bearing such facsimile signatures or facsimile seal shall be valid and binding upon the Company and any such power so executed and certified by facsimile signatures and facsimile seal shall be valid and binding upon the Company in the future with respect to any bond or undertaking to which it is attached.



IN TESTIMONY WHEREOF, INTERNATIONAL FIDELITY INSURANCE COMPANY has caused this instrument to be signed and its corporate seal to be affixed by its authorized officer, this 16th day of October, A.D. 2007.

INTERNATIONAL FIDELITY INSURANCE COMPANY

STATE OF NEW JERSEY
County of Essex

Secretary

On this 16th day of October 2007, before me came the individual who executed the preceding instrument, to me personally known, and, being by me duly sworn, said the he is the therein described and authorized officer of the INTERNATIONAL FIDELITY INSURANCE COMPANY; that the seal affixed to said instrument is the Corporate Seal of said Company; that the said Corporate Seal and his signature were duly affixed by order of the Board of Directors of said Company.



IN TESTIMONY WHEREOF, I have hereunto set my hand affixed my Official Seal, at the City of Newark, New Jersey the day and year first above written.

A NOTARY PUBLIC OF NEW JERSEY
My Commission Expires Nov. 21, 2010

CERTIFICATION

I, the undersigned officer of INTERNATIONAL FIDELITY INSURANCE COMPANY do hereby certify that I have compared the foregoing copy of the Power of Attorney and affidavit, and the copy of the Section of the By-Laws of said Company as set forth in said Power of Attorney, with the ORIGINALS ON IN THE HOME OFFICE OF SAID COMPANY, and that the same are correct transcripts thereof, and of the whole of the said originals, and that the said Power of Attorney has not been revoked and is now in full force and effect

IN TESTIMONY WHEREOF, I have hereunto set my hand this 20th day of October, 2010

Assistant Secretary

**NONCOLLUSION AFFIDAVIT TO BE EXECUTED BY BIDDER AND
SUBMITTED WITH BID**

State of California) ss.
County of Riverside)

Armand Gonzales

being first duly sworn, deposes and says:

That he or she is President of Armand Gonzales Inc. dba
Gonzales Construction

the party making the foregoing bid; that the bid is not made in the interest of, or on behalf of, any undisclosed person, partnership, company, association, organization, or corporation; that the bid is genuine and not collusive or sham; that the bidder has not directly or indirectly induced or solicited any other bidder to put in a false or sham bid, and has not directly or indirectly colluded, conspired, connived, or agreed with any bidder or anyone else to put in a sham bid, or that anyone shall refrain from bidding; that the bidder has not in any manner, directly or indirectly, sought by agreement, communication, or conference with anyone to fix the bid price of the bidder or any other bidder, or to fix any overhead, profit, or cost element of the bid price, or of that of any other bidder, or to secure any advantage against the public body awarding the contract of anyone interested in the proposed contract; that all statements contained in the bid are true; and, further, that the bidder has not, directly or indirectly, submitted his or her bid price or any breakdown thereof, or the contents thereof, or divulged information or data relative thereto, or paid, and will not pay, any fee to any corporation, partnership, company association, organization, bid depository, or to any member or agent thereof to effectuate a collusive or sham bid.

Armand Gonzales, President

Signature

Subscribed and sworn to before me this 22 day of oct, 2010 by
Armand Gonzales.

Sharon Daniali
Signature of officer administering oath

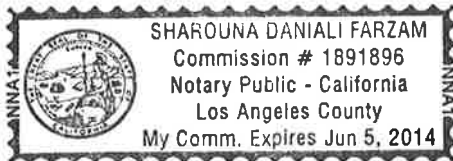

Construction
Blvd., 2nd Floor
CA 91356

Rancho Jurupa Regional Sports Complex
Clerk of the Board of Supervisors, 1st floor, County
Administrative Center
4080 Lemon St., Riverside, CA 92501
October 25, 2010 at 2:30pm

SEALED BID RECEIVED
CLERK OF THE BOARD OF SUPERVISORS

RECEIVED RIVERSIDE COUNTY
CLERK / BOARD OF SUPERVISORS
2010 OCT 25 PM 2:16

CONTRACTOR'S PROPOSAL
Rancho Jurupa Regional Sports Complex

TO THE GOVERNING BOARD OF THE REDEVELOPMENT AGENCY FOR THE COUNTY OF RIVERSIDE:

Date: October 25, 2010

Bidder: Sanders Construction Services, Inc.

The undersigned, having carefully examined the proposed site and the Plans and Specifications, the Notice Inviting Bids, the Instructions to Bidders, the Agreement Form, the Bond Forms, the General Conditions for the Construction of the Rancho Jurupa Regional Sports Complex, hereby proposes and agrees to furnish all tools, equipment, services, apparatus, facilities, transportation, labor and materials necessary to complete the work in strict conformity with the Plans and Specifications, including all work specified in Addenda numbered and dated:

Addendum No. 001 Date 10.7.2010

Addendum No. 002 Date 10.13.2010

Addendum No. 003 Date 10.15.10

Addendum No. 004 Date 10.20.10

Addendum No. 005 Date 10.22.10

Addendum No. _____ Date _____

Addendum No. _____ Date _____

BASE BID

Clear and Grub/Demolition:

\$ 22,000

Grading and Drainage:

\$ 1,550,000

Water and Sewer:

\$ 23,000

Electrical:

\$ 1,200,000

Site Construction:

\$ ~~6,615,000~~ 7,000,000

Irrigation:

\$ 560,000

Planting:

\$ 650,000

For the total Base Bid Ten Million, five hundred & one thousand dollars
(in words)

(\$ 10,501,000)

including all applicable taxes, permits, licenses, **AND Course of Construction Insurance.**

ALTERNATE BID ITEMS

(Add or Deduct state which)

1. Alternate Bid Synthetic Turf "FieldTurf Prestige XM50"
(refer to specifications section 02890.05 A)

\$ 196,000

~~Add~~ Deduct

2. Alternate Bid Synthetic Turf "Mondo Green Ecofill MF4563"
(refer to specifications section 02890.05 B)

\$ 640,000

Add

3. Alternate Bid Synthetic Turf "Sprinturf Ultrablade DF"
(refer to specifications section 02890.05 C)

\$ 385,000

Deduct

4. Alternate Bid Football Field
Item includes football field striping, combination football/soccer goals and steel posts and netting. Original soccer goals shall be included in the base bid.

\$ 10,000

Add

5. Alternate Bid _____
(as listed by contractor)

\$ _____

6. Alternate Bid _____
(as listed by contractor)

\$ _____

7. Alternate Bid _____
(as listed by contractor)

\$ _____

8. Alternate Bid _____
(as listed by contractor)

\$ _____

9. Alternate Bid _____
(as listed by contractor)

\$ _____

10. Alternate Bid _____
(as listed by contractor)

\$ _____

And,
Cost of Contractor's Course of Construction Insurance _____ dollars (\$ _____) and
deductible \$ _____.

Bids must be submitted on all items (except Alternate Bid items 5-10 if not needed by contractor). Failure to bid on all items may result in the bid being rejected as non-responsive. The basis for award will be the qualified bidder with the lowest total of the Base Bid WITH COURSE OF CONSTRUCTION INSURANCE. Alternates may be awarded in any order after determination of the lowest responsible and responsive bidder.

DESIGNATION OF SUBCONTRACTORS

In compliance with Section 4104 of the Public Contract Code the undersigned submits the following complete list of each Subcontractor who will perform work or labor or render service in or about the construction/installation in an amount in excess of 1/100th 1% of said total bid.

<u>PORTION OF THE WORK</u>	<u>SUBCONTRACTOR</u>	<u>ADDRESS</u>
Grading - Dependable		Riverside
Site utilities -	PSI Plumbing	11959 Rivera Rd - Santa Fe Springs
Landscape & IRB -	Advanced Landscape	Woodland Hills
Dewatering -	Viking	Sacramento
Paving -	Pave West	La Habra
Site concrete -	Petaluma Concrete	633 Mohr St. Placentia
Field Turf -	Field Turf	Quebec, Montreal
Pre Cast -	Quick-Crete	Novco
Fencing -	Landmark	Montclair
Masonry -	Steve Lynch Masonry	P.O. Box 745 - La Habra
Pre Fab Buildings -	Public Restrooms Co	Reno
Play Ground Equip -	Coast Recreation	Costa Mesa
Shade Shelters -	USA Shade	Costa Mesa
Shade Structures Structures -	Coast Recreation	Costa Mesa
Painting -	Bithell	Covina
Electric -	CREO	1241 Wright St. Santa Ana

AWARD OF CONTRACT

The undersigned fully understands that a Contract is formed upon the acceptance of this Proposal by the Owner and the undersigned further agrees that upon request he will promptly execute and deliver to Owner a written memorial of the Contract together with the required Payment and Performance Bonds and proof of insurance.

BID GUARANTEE

The enclosed certified or cashier's check or bidder's bond on approved form, made payable to the Owner in the amount of ten percent of the total bid submitted herewith, is hereby given as a guarantee that the bidder will execute and deliver the above mentioned written memorial and required bonds and insurance if awarded the contract, and in the event that the undersigned fails or refuses to execute and deliver said documents, such check or bond is to be charged with the costs of the damages experienced by the Owner as a result of such failure or refusal, including but not limited to publication costs, the difference in money between the amount of the bid of the said principal and the amount for which obligee may legally contract with another party to perform the said work if such amount be in excess of the former, building lease or rental costs, transportation costs and additional salary costs that result from the delay due to the principal's default on the awarded contract. In no event, however, shall the Surety's liability exceed the penal sum hereof.

Name of Bidder: Sanders Construction Services, Inc.

Type of Organization: Corporation

Signed By: Patrick B. Sanders X 

Title of Signer: President

Address of Bidder: 20331 Lake Forest Drive, Ste C2

Lake Forest, CA 92630

Telephone No.: 949-951-6944

Contractor's License No.: 716521

Classification: B Expiration Date: 1-31-2012

Affix Seal
If
Corporation

LICENSURE STATEMENTS ARE MADE UNDER PENALTY OF PERJURY

If bidder is a corporation, and signer is not President or Secretary, attach a certified copy of By-Laws or resolution authorizing execution. If bidder is a corporation, affix corporate seal. If signer is an agent, attach Power of Attorney. If bidder is not an individual, list names of other persons authorized to bind the organization.

**NONCOLLUSION AFFIDAVIT TO BE EXECUTED BY BIDDER AND
SUBMITTED WITH BID**

State of California) ss.
County of Riverside)

Patrick B. Sanders, being first duly sworn, deposes and says:

That he or she is President of Sanders Construction Services, Inc. the party making the foregoing bid; that the bid is not made in the interest of, or on behalf of, any undisclosed person, partnership, company, association, organization, or corporation; that the bid is genuine and not collusive or sham; that the bidder has not directly or indirectly induced or solicited any other bidder to put in a false or sham bid, and has not directly or indirectly colluded, conspired, connived, or agreed with any bidder or anyone else to put in a sham bid, or that anyone shall refrain from bidding; that the bidder has not in any manner, directly or indirectly, sought by agreement, communication, or conference with anyone to fix the bid price of the bidder or any other bidder, or to fix any overhead, profit, or cost element of the bid price, or of that of any other bidder, or to secure any advantage against the public body awarding the contract of anyone interested in the proposed contract; that all statements contained in the bid are true; and, further, that the bidder has not, directly or indirectly, submitted his or her bid price or any breakdown thereof, or the contents thereof, or divulged information or data relative thereto, or paid, and will not pay, any fee to any corporation, partnership, company, association, organization, bid depository, or to any member or agent thereof to effectuate a collusive or sham bid.

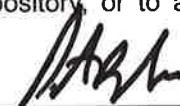

Signature

Subscribed and sworn to before me this 25th day of October, 2010



Signature of officer administering oath



CALIFORNIA ALL-PURPOSE ACKNOWLEDGMENT

State of California

County of ORANGE

On OCTOBER 25 2010 before me, ANNIE BARCOCK, NOTARY PUBLIC

personally appeared PATRICK B. SANDERS

who proved to me on the basis of satisfactory evidence to be the person(s) whose name(s) is/are subscribed to the within instrument and acknowledged to me that he/she/they executed the same in his/her/their authorized capacity(ies), and that by his/her/their signature(s) on the instrument the person(s), or the entity upon behalf of which the person(s) acted, executed the instrument.



I certify under PENALTY OF PERJURY under the laws of the State of California that the foregoing paragraph is true and correct.

WITNESS my hand and official seal.
Signature [Handwritten Signature]
Signature of Notary Public

Place Notary Seal Above

OPTIONAL

Though the information below is not required by law, it may prove valuable to persons relying on the document and could prevent fraudulent removal and reattachment of this form to another document.

Description of Attached Document

Title or Type of Document: NON COLLUSION AFFIDAVIT

Document Date: OCTOBER 25, 2010 Number of Pages: _____

Signer(s) Other Than Named Above: _____

Capacity(ies) Claimed by Signer(s)

- Signer's Name: _____
- Individual
 - Corporate Officer — Title(s): _____
 - Partner — Limited General
 - Attorney in Fact
 - Trustee
 - Guardian or Conservator
 - Other: _____



Signer Is Representing: _____

- Signer's Name: _____
- Individual
 - Corporate Officer — Title(s): _____
 - Partner — Limited General
 - Attorney in Fact
 - Trustee
 - Guardian or Conservator
 - Other: _____



Signer Is Representing: _____

Bid Bond

KNOWN TO ALL MEN BY THESE PRESENTS, that we, the undersigned SANDERS CONSTRUCTION SERVICES, as Principal; and NORTH AMERICAN SPECIALTY * as Surety, are hereby held and firmly bound unto the Redevelopment Agency for the County of Riverside, hereinafter called the "Owner", in the sum of TEN PERCENT OF THE AMT. BID Dollars (\$ 10% OF BID) for the payment of such sum, well and truly to be made, do hereby jointly and severally bind ourselves, our heirs, executors, administrators, successors and assigns.

WHEREAS, the said Principal is herewith submitting its Proposal for the RANCHO JURUPA REGIONAL SPORTS COMPLEX

THE CONDITION OF THE ABOVE OBLIGATION IS SUCH, that if the aforesaid Principal shall be awarded the Contract upon said Proposal and shall, within the required number of days after the notice of such award, execute a written memorial of the awarded Contract and submit the required Labor and Material Payment and faithful Performance Bond and proof of insurance, then this obligation shall be null and void; and in the event that the Principal fails and/or refuses to execute and deliver said documents this Bond will be charged with the costs of the damages experienced by the Owner as a result of such refusal, including but not limited to, publication cost, the difference in money between the amount of the bid of the said Principal and the amount for which the obligee may legally contract with another party to perform the said work if such amount be in excess of the former; building lease or rental costs, transportation cost, and additional salary costs that result from the delay due to the Principal's default on the awarded Contract. In no event however, shall the Surety's liability exceed the penal sum hereof.

The Surety, for value received, hereby stipulates and agrees that the obligations of said Surety and its bond shall be in no way impaired or affected by any extension of the time within which the Owner may accept such bid; and said Surety does hereby waive notice of any such extension.

IN WITNESS WHEREOF, the above bounded parties have executed this instrument under their separate seals this 18th day of OCTOBER, 2010, the name and corporate seal of each corporate party being hereto affixed and those present duly signed by its undersigned representative, pursuant to authority of its governing body.

SANDERS CONSTRUCTION SERVICES
(Firm Name - Principal)
20331 LAKE FOREST DR. #C2, LAKE FOREST CA 92630
(Business Address)

By 
(Original Signature)
President
(Title)

Affix Seal
If
Corporation

NORTH AMERICAN SPECIALTY INSURANCE COMPANY
(Corporation Name - Surety)
701 S. PARKER ST STE 3800, ORANGE CA 92868
(Business Address)

By 
(Original Signature) MICHAEL D. STONG, ATTORNEY-IN-FACT

Affix
Corporate
Seal

CALIFORNIA ALL-PURPOSE CERTIFICATE OF ACKNOWLEDGMENT

State of California

County of RIVERSIDE

On 10/18/10 before me, R. NAPPI "NOTARY PUBLIC",
(Here insert name and title of the officer)

personally appeared MICHAEL D. STONG,

who proved to me on the basis of satisfactory evidence to be the person(s) whose name(s) is/are subscribed to the within instrument and acknowledged to me that he/she/they executed the same in his/her/their authorized capacity(ies), and that by his/her/their signature(s) on the instrument the person(s), or the entity upon behalf of which the person(s) acted, executed the instrument.

I certify under PENALTY OF PERJURY under the laws of the State of California that the foregoing paragraph is true and correct.

WITNESS my hand and official seal.

R. Nappi
 Signature of Notary Public

(Notary Seal)

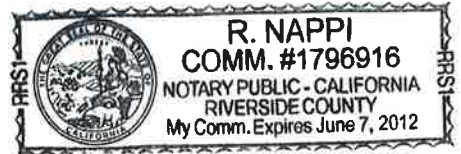

ADDITIONAL OPTIONAL INFORMATION

DESCRIPTION OF THE ATTACHED DOCUMENT

(Title or description of attached document)

(Title or description of attached document continued)

Number of Pages _____ Document Date _____

(Additional information)

CAPACITY CLAIMED BY THE SIGNER

- Individual (s)
- Corporate Officer

(Title)
- Partner(s)
- Attorney-in-Fact
- Trustee(s)
- Other _____

INSTRUCTIONS FOR COMPLETING THIS FORM

Any acknowledgment completed in California must contain verbiage exactly as appears above in the notary section or a separate acknowledgment form must be properly completed and attached to that document. The only exception is if a document is to be recorded outside of California. In such instances, any alternative acknowledgment verbiage as may be printed on such a document so long as the verbiage does not require the notary to do something that is illegal for a notary in California (i.e. certifying the authorized capacity of the signer). Please check the document carefully for proper notarial wording and attach this form if required.

- State and County information must be the State and County where the document signer(s) personally appeared before the notary public for acknowledgment.
- Date of notarization must be the date that the signer(s) personally appeared which must also be the same date the acknowledgment is completed.
- The notary public must print his or her name as it appears within his or her commission followed by a comma and then your title (notary public).
- Print the name(s) of document signer(s) who personally appear at the time of notarization.
- Indicate the correct singular or plural forms by crossing off incorrect forms (i.e. ~~he/she/they~~, is /are) or circling the correct forms. Failure to correctly indicate this information may lead to rejection of document recording.
- The notary seal impression must be clear and photographically reproducible. Impression must not cover text or lines. If seal impression smudges, re-seal if a sufficient area permits, otherwise complete a different acknowledgment form.
- Signature of the notary public must match the signature on file with the office of the county clerk.
 - ❖ Additional information is not required but could help to ensure this acknowledgment is not misused or attached to a different document.
 - ❖ Indicate title or type of attached document, number of pages and date.
 - ❖ Indicate the capacity claimed by the signer. If the claimed capacity is a corporate officer, indicate the title (i.e. CEO, CFO, Secretary).
- Securely attach this document to the signed document

NAS SURETY GROUP

NORTH AMERICAN SPECIALTY INSURANCE COMPANY
WASHINGTON INTERNATIONAL INSURANCE COMPANY

GENERAL POWER OF ATTORNEY

KNOW ALL MEN BY THESE PRESENTS, THAT North American Specialty Insurance Company, a corporation duly organized and existing under laws of the State of New Hampshire, and having its principal office in the City of Manchester, New Hampshire, and Washington International Insurance Company, a corporation organized and existing under the laws of the State of New Hampshire and having its principal office in the City of Schaumburg, Illinois, each does hereby make, constitute and appoint:

ROSEMARY NAPPI,
JEREMY PENDERGAST and MICHAEL D. STONG
JOINTLY OR SEVERALLY

Its true and lawful Attorney(s)-in-Fact, to make, execute, seal and deliver, for and on its behalf and as its act and deed, bonds or other writings obligatory in the nature of a bond on behalf of each of said Companies, as surety, on contracts of suretyship as are or may be required or permitted by law, regulation, contract or otherwise, provided that no bond or undertaking or contract or suretyship executed under this authority shall exceed the amount of:

TWENTY-FIVE MILLION (\$25,000,000.00) DOLLARS

This Power of Attorney is granted and is signed by facsimile under and by the authority of the following Resolutions adopted by the Boards of Directors of both North American Specialty Insurance Company and Washington International Insurance Company at meetings duly called and held on the 24th of March, 2000:

"RESOLVED, that any two of the Presidents, any Managing Director, any Senior Vice President, any Vice President, any Assistant Vice President, the Secretary or any Assistant Secretary be, and each or any of them hereby is authorized to execute a Power of Attorney qualifying the attorney named in the given Power of Attorney to execute on behalf of the Company bonds, undertakings and all contracts of surety, and that each or any of them hereby is authorized to attest to the execution of any such Power of Attorney and to attach therein the seal of the Company; and it is

FURTHER RESOLVED, that the signature of such officers and the seal of the Company may be affixed to any such Power of Attorney or to any certificate relating thereto by facsimile, and any such Power of Attorney or certificate bearing such facsimile signatures or facsimile seal shall be binding upon the Company when so affixed and in the future with regard to any bond, undertaking or contract of surety to which it is attached."



By [Signature]
Steven P. Anderson, President & Chief Executive Officer of Washington International Insurance Company & Senior Vice President of North American Specialty Insurance Company



By [Signature]
David M. Layman, Senior Vice President of Washington International Insurance Company & Vice President of North American Specialty Insurance Company

IN WITNESS WHEREOF, North American Specialty Insurance Company and Washington International Insurance Company have caused their official seals to be hereunto affixed, and these presents to be signed by their authorized officers this 29th day of March, 20 10.

North American Specialty Insurance Company
Washington International Insurance Company

State of Illinois
County of Cook ss:

On this 29th day of March, 20 10, before me, a Notary Public personally appeared Steven P. Anderson, President and CEO of Washington International Insurance Company and Senior Vice President of North American Specialty Insurance Company and David M. Layman, Senior Vice President of Washington International Insurance Company and Vice President of North American Specialty Insurance Company, personally known to me, who being by me duly sworn, acknowledged that they signed the above Power of Attorney as officers of and acknowledged said instrument to be the voluntary act and deed of their respective companies.

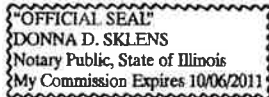

[Signature]
Donna D. Sklens, Notary Public

I, James A. Carpenter, the duly elected Assistant Secretary of North American Specialty Insurance Company and Washington International Insurance Company, do hereby certify that the above and foregoing is a true and correct copy of a Power of Attorney given by said North American Specialty Insurance Company and Washington International Insurance Company, which is still in full force and effect.

IN WITNESS WHEREOF, I have set my hand and affixed the seals of the Companies this 18th day of October, 20 10.

[Signature]

James A. Carpenter, Vice President & Assistant Secretary of Washington International Insurance Company & North American Specialty Insurance Company



ECONOMIC DEVELOPMENT AGENCY – COUNTY OF RIVERSIDE

ADDENDUM NO. 001

TO BIDDING DOCUMENTS, CONTRACT, BASIC SPECIFICATIONS, AND SPECIAL REQUIREMENTS
FOR
RANCHO JURUPA REGIONAL SPORTS COMPLEX

Bidders are advised that the Contract Documents for the above referenced contract are hereby amended in the following manner and in the following manner only:

A. GENERAL ITEMS

1. All provisions of this Addendum No. 001 are hereby incorporated into the contract documents, and bidders shall account for all provisions pursuant to this Addendum No. 001 in submitting their bid proposals. Each bidder shall include a dated and signed copy of this Addendum No. 001 with his sealed bid proposal.
2. Mandatory Job Walk will take place on Wednesday, October 13, 2010 at 10:00 am. The location of the job walk will be at 4800 Crestmore Road, Riverside CA 92509-6839. Follow the directional signs into the Park. The meeting location will be at the Pecan Shade Shelter.
3. Plans and specifications are available at OCB Reprographics of Riverside. Please contact them for cost of plans and specifications.

B. PLAN & SPECIFICATION ITEMS

1. Replace the following specification sections with the specifications attached.
02441, 02461, 02740, 02763, 02783, 02890, 09860, 16000
2. Add the following specification sections attached.
13000, 13120
3. Turf shall be SOD only. Remove reference to hydroseed turf on planting plans.
4. Construction Plan item 24b on sheet CP-2 shall be changed to item 24a.

5. Contractor shall note the requirement of providing for turnover to the County a synthetic turf sweeper and groomer as part of the base bid cost as noted on page 9 of specification section 02890.
6. Contractor shall note that the drainline shown on sheets C5 and C9 shall NOT be installed under the concrete paving as shown. Drainline shall be installed as shown on sheet TD-1.
7. The **County will provide** all site survey services. Section 8.9.1 under "LAYOUT OF WORK" shall be modified accordingly.
8. The attached "Contractor's Proposal" shall be used in place of the one in the original bid specifications.

DATED: October 7, 2010

By: _____
Jason Plotkin, Project Manager

10.7-10
Date Received by Bidder

By: 
Bidder's Signature

Patrick B. Sanders
Typed or Printed Name



2

ECONOMIC DEVELOPMENT AGENCY – COUNTY OF RIVERSIDE

ADDENDUM NO. 002

TO BIDDING DOCUMENTS, CONTRACT, BASIC SPECIFICATIONS, AND SPECIAL REQUIREMENTS FOR RANCHO JURUPA REGIONAL SPORTS COMPLEX

Bidders are advised that the Contract Documents for the above referenced contract are hereby amended in the following manner and in the following manner only:

A. GENERAL

- 1. All provisions of this Addendum No. 002 are hereby incorporated into the contract documents, and bidders shall account for all provisions pursuant to this Addendum No. 002 in submitting their bid proposals. Each bidder shall include a dated and signed copy of this Addendum No. 002 with his sealed bid proposal.
2. The following Addendum No. 002 contains the job walk sign-in sheets, agenda, and answers to questions asked at the job walk.

DATED: October 13, 2010

By: Jason Plotkin, Project Manager

Date Received by Bidder

By: Bidder's Signature

Patrick B. Sanders, President
Typed or Printed Name



ECONOMIC DEVELOPMENT AGENCY – COUNTY OF RIVERSIDE

ADDENDUM NO. 003

TO BIDDING DOCUMENTS, CONTRACT, BASIC SPECIFICATIONS, AND SPECIAL REQUIREMENTS
FOR
RANCHO JURUPA REGIONAL SPORTS COMPLEX

Bidders are advised that the Contract Documents for the above referenced contract are hereby amended in the following manner and in the following manner only:

A. GENERAL ITEMS

- 1. All provisions of this Addendum No. 003 are hereby incorporated into the contract documents, and bidders shall account for all provisions pursuant to this Addendum No. 003 in submitting their bid proposals. Each bidder shall include a dated and signed copy of this Addendum No. 003 with his sealed bid proposal.

B. PLAN & SPECIFICATION ITEMS

- 1. Add football field striping, combination football/soccer goals and steel posts and netting to the southeast synthetic turf field (Field 2). Refer to attached sheets:
"RJRSC - Revised Sheet CP-2 (addendum #3).pdf"
"RJRSC - Revised Sheet LP-2 (addendum #3).pdf"
"RJRSC - Revised Sheet CD-4 (addendum #3).pdf"
- 2. Revise soccer goals on Fields 5 and 6 per attached sheet:
"RJRSC - Revised Sheet CP-2 (addendum #3).pdf".
- 3. Note locations of playground gravel sumps added to detail 'A' on attached sheet:
"RJRSC - Revised Sheet CD-2 (addendum #3).pdf".
- 4. Change Ackerstone paver color to "Charcoal Brown Buff" as shown on attached sheet:
"RJRSC - Revised Sheet CP-2 (addendum #3).pdf"

P.O. Box 1180 • Riverside, California 92502 • T: 951.955.8716 • F: 951.955.4884 www.rivcoeda.org

Administration
 Aviation
 Business Intelligence
 Cultural Services
 Community Services
 Custodial

Housing
 Housing Authority
 Information Technology
 Maintenance
 Marketing

Economic Development
 Edward-Dean Museum
 Environmental Planning
 Fair & National Date Festival
 Foreign Trade
 Graffiti Abatement

Parking
 Project Management
 Purchasing Group
 Real Property
 Redevelopment Agency
 Workforce Development

5. Replace specification Section ~~02890~~ Synthetic Turf with the attached file:
~~02890~~ SYNTHETIC TURF SYSTEM (rev for Addendum #3).pdf

Note change to 02890.06 item 2:

2. *In the event that the Prime Contractor does not meet these requirements, a sub-contractor may be listed that does meet the requirements specified in item 1 above. The Prime Contractor shall provide evidence of experience by the listed sub-contractor in preparing drainage base systems for synthetic turf and the sub-contractor must have installed a minimum of 10 sub-grade drainage base systems for synthetic turf playing fields in the past 3 years in California.*

6. Replace the Contractor's Proposal with the attached file:
"RJRSC Contractor's Proposal - Addendum #3 (10-15-10).pdf"

DATED: October 15, 2010

By: _____
Jason Plotkin, Project Manager

10.15.10
Date Received by Bidder

By: 
Bidder's Signature

Patrick B. Sanders
Typed or Printed Name



ECONOMIC DEVELOPMENT AGENCY – COUNTY OF RIVERSIDE

ADDENDUM NO. 004

TO BIDDING DOCUMENTS, CONTRACT, BASIC SPECIFICATIONS, AND SPECIAL REQUIREMENTS
FOR
RANCHO JURUPA REGIONAL SPORTS COMPLEX

Bidders are advised that the Contract Documents for the above referenced contract are hereby amended in the following manner and in the following manner only:

A. GENERAL ITEMS

1. All provisions of this Addendum No. 004 are hereby incorporated into the contract documents, and bidders shall account for all provisions pursuant to this Addendum No. 004 in submitting their bid proposals. Each bidder shall include a dated and signed copy of this Addendum No. 004 with his sealed bid proposal.
2. The cutoff for RFI's has changed to **Thursday, October 21, 2010 at 2:30pm**

B. PLAN & SPECIFICATION ITEMS

1. Change the play equipment model number in the construction legend items "D" and "E" on detail "A" sheet CD-2, to 31360-1-2.
2. Specification Section 13000.F.1. shall be changed to "The **OWNER** is responsible for the site survey and staking the building location,"
3. The quantity of picnic tables on CP-1 and CP-2, item 16 shall be changed to **52**.
4. The retaining walls located along the north property line shall be constructed per detail H, sheet C2 as indicated on sheets C3 and C4. The retaining walls located on the north and west sides of the soccer field adjacent to the concrete paving shall be constructed per details A and D, sheet CD-3 as indicated on sheet CP-2.
5. Detail A and D on sheet CD-3 show a typical mow curb against wall, where turf occurs. It then references detail F, on CD-1 which is the monument sign, which is incorrect. A mow curb detail has been included as part of this addendum.

6. Specification Section 02890.08 Field Conditions **Part A** shall be removed from the specifications.
7. The contractor shall be required to prepare the Storm Water Pollution Prevention Plan (SWPPP) for the project. The SWPPP shall meet all requirements of the **2009-0009-DWQ Construction general permit** which can be found at:
http://www.swrcb.ca.gov/water_issues/programs/stormwater/constpermits.shtml
8. The connection to the existing flood control down drain shall be made utilizing a concrete collar in accordance with APWA STD 380-4.
9. The electrical plan sheets (E-1, E-2, E-3, E-4, E-5, E-6, E-7, E-8, E-9, E-10) dated 5/10/10 shall be replaced with the attached sheets dated 5/27/10. Information missing from the original sheets has been added.
10. All work within 5' of the synthetic turf system, both above and below ground, must be performed by a qualified contractor according to the project specifications. Pre-qualifications shall be submitted for the synthetic field installers **AND** sub-drain and crushed rock preparation installers. The pre-qualifications can be submitted **within 24 hours after the bid opening by the three apparent low bidders**.
11. The 15" drain line indicated on sheet C9 should be revised to the 18" perforated drain as indicated within the specs. The 48" perforated drain line adjacent to the parking lot is the infiltration trench drain for water quality purposes and is considered to be part of the perimeter drain system for the synthetic turf fields. In addition, all drain inlets and laterals that connect to the perimeter drain system are considered part of the synthetic turf sub-drainage system and must be installed by a qualified sub-drainage subcontractor with 10 fields in 3 years experience per the project specifications. The connections must be made to 5' outside of the trench/synthetic turf area where a qualified underground utility contractor may pick up the connection and install the rest of the upstream system.
12. The sidewalk that is referred to in detail C sheet C-3 is the public sidewalk within the County right-of-way that is indicated on the SP sheets. This sidewalk per County standard is a 4" thick sidewalk. Interior sidewalks (outside of the R/W) shall be 6" thick per the CP sheets.
13. Sheets C7 and C11 were labeled incorrectly; the scale of these sheets is 1"=30'.
14. Wire note #1 on sheet IP-1 specifies "All valve control / common wires shall be installed in a schedule 40 gray PVC conduit per detail "B" sheet ID-1". The detail reference should be **detail "I" sheet ID-1**. All common, pilot and spare wires shall be installed inside schedule 40 PVC grey conduit in a **continuous route** from controllers to all the remote control valve locations.
15. The pipe for all drinking fountain lines shall be schedule 40 PVC.
16. All 6" irrigation pipe shall be Class 200 PVC Ring-Tite.

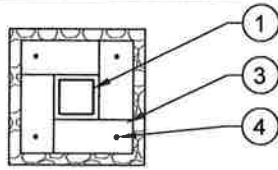

PLAN

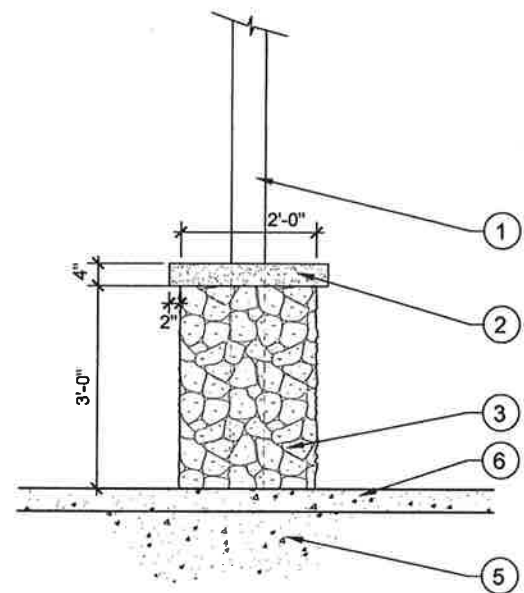

ELEVATION

- ① SHADE STRUCTURE POST
- ② POUR-IN-PLACE CONCRETE CAP WITH MEDIUM SAND BLAST FINISH
- ③ 6 x 8 x 16 PRECISION BLOCK COLUMN WITH COBBLESTONE VENEER - GROUT SOLID
- ④ #4 VERTICAL REBAR - EXTEND 6" INTO CONCRETE FOOTING
- ⑤ CONCRETE FOOTING PER SHADE STRUCTURE DETAIL
- ⑥ CONCRETE PAVING PER PLAN

APPLY 'VITROCHEM' TO ALL EXPOSED CONCRETE AND STONE VENEER PER SPECIFICATIONS

Project Name

RANCHO JURUPA REGIONAL SPORTS COMPLEX



6216 BROCKTON AVENUE
 SUITE 212
 RIVERSIDE, CA 92506
 LIC. #1512
 PH. (951) 781-1930
 FAX (951) 686-8091

Sheet Title
**STONE VENEER
 COLUMN**

Date **10/20/10**
 RHA Project No. **08113**
 Addendum No. **4**

Scale **N.T.S.**
 Sheet No
1

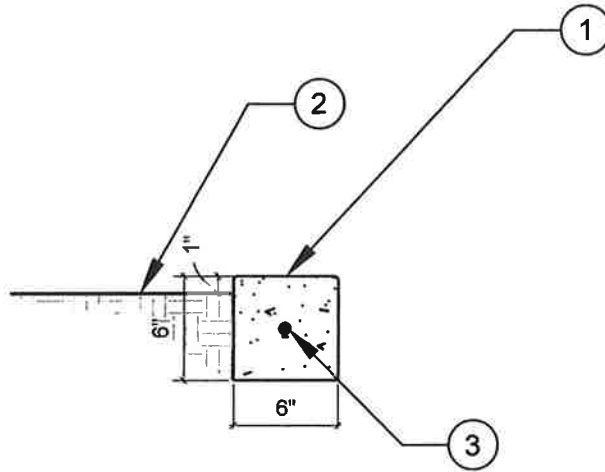

- ① 2500 PSI CONCRETE MOW STRIP NATURAL GREY SMOOTH TROWEL FINISH 1/4" RAD. TO ALL EDGES. INSTALL 1/2" PREFORMED EXPANSION JOINTS @ 15' O/C MAX., AND @ BEGINNING & END OF RADIUS. COLD JOINT/CONSTRUCTION JOINT EVERY 60'.
- ② FINISH GRADE AT TURF AREAS: 1" BELOW TOP OF MOW STRIP
- ③ #3 REBAR CONT. (CENTERED) LAP BARS 8" @ SPLICES & TIE

Project Name

RANCHO JURUPA REGIONAL SPORTS COMPLEX



6216 BROCKTON AVENUE
 SUITE 212
 RIVERSIDE, CA 92506
 LIC. #1512
 PH. (951) 781-1930
 FAX (951) 686-8091

Sheet Title
MOW CURB

Date
10/20/10

Scale
N.T.S.

RHA Project No.
08113

Sheet No

Addendum No.
4

2

- 17. The exterior of the trash enclosure walls shall have a stone veneer wainscot to match the electrical enclosure on detail "E" sheet CD-2.
- 18. Refer to Stone Veneer Column detail included in Addendum #4 for detail on stone veneer columns at the shade structure posts.

DATED: October 20, 2010

Date Received by Bidder

By: _____
Jason Plotkin, Project Manager

By: 

Bidder's Signature

PATRICK B SANDERS
Typed or Printed Name

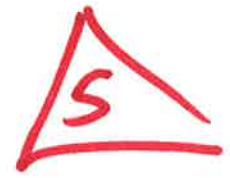

ECONOMIC DEVELOPMENT AGENCY – COUNTY OF RIVERSIDE

ADDENDUM NO. 005

TO BIDDING DOCUMENTS, CONTRACT, BASIC SPECIFICATIONS, AND SPECIAL REQUIREMENTS
FOR
RANCHO JURUPA REGIONAL SPORTS COMPLEX

Bidders are advised that the Contract Documents for the above referenced contract are hereby amended in the following manner and in the following manner only:

A. GENERAL ITEMS

1. All provisions of this Addendum No. 005 are hereby incorporated into the contract documents, and bidders shall account for all provisions pursuant to this Addendum No. 005 in submitting their bid proposals. Each bidder shall include a dated and signed copy of this Addendum No. 005 with his sealed bid proposal.

B. PLAN & SPECIFICATION ITEMS

1. All concrete paving shall be 3,250 psi per plans. The reference to 4,000 psi concrete in the Geotechnical Report shall be revised to 3,250 psi.
2. Detail 'C', Sheet CD-3 shall be modified to have the gravel base and geotextile fabric extend 18" beyond the edge of the concrete pavers.
3. Construct a 6" wide by 16" deep concrete curb to separate the asphalt paving and permeable pavers. Install continuous #4 rebar 3" below top of curb and 1" deep score joints at 10' O.C. The top of curb is to be flush with the adjacent pavers and asphalt paving.
4. The existing stump and tree along Loring Ranch are to be removed.
5. The reference to hydroseed turf on sheets PP-1 and PP-2 shall be removed. The base bid shall be sod turf as specified on the plans.
6. The alternate bid item for the football striping shall also include increasing the length of the synthetic turf blades to a minimum of 2.5".

DATED: October 22, 2010

By: _____
Jason Plotkin, Project Manager

Date Received by Bidder

By:  _____
Bidder's Signature

Patrick B. Sanders, President
Typed or Printed Name

SEALED BID RECEIVED
CLERK OF THE BOARD OF SUPERVISORS

RECEIVED RIVERSIDE COUNTY
CLERK / BOARD OF SUPERVISORS

2010 OCT 25 PM 2:24



**Sanders
Construction
Services**

20331 Lake Forest Dr., Suite C2 • Lake Forest, CA 92630

Rancho Jurupa Regional Sports Park Imprvmts.
October 25, 2010 2:30pm

Clerk of the Board of Supervisors
1st Floor of the County Admin Center
4080 Lemon Street
Riverside, CA 92501

CONTRACTOR'S PROPOSAL
Rancho Jurupa Regional Sports Complex

TO THE GOVERNING BOARD OF THE REDEVELOPMENT AGENCY FOR THE COUNTY OF RIVERSIDE:

Date: October 25, 2010

Bidder: EDGE Development, Inc.

The undersigned, having carefully examined the proposed site and the Plans and Specifications, the Notice Inviting Bids, the Instructions to Bidders, the Agreement Form, the Bond Forms, the General Conditions for the Construction of the Rancho Jurupa Regional Sports Complex, hereby proposes and agrees to furnish all tools, equipment, services, apparatus, facilities, transportation, labor and materials necessary to complete the work in strict conformity with the Plans and Specifications, including all work specified in Addenda numbered and dated:

- Addendum No. 1 Date October 7, 2010
- Addendum No. 2 Date October 13, 2010
- Addendum No. 3 Date October 15, 2010
- Addendum No. 4 Date October 20, 2010
- Addendum No. 5 Date October 22, 2010
- Addendum No. _____ Date _____
- Addendum No. _____ Date _____

BASE BID

A	Clear and Grub/Demolition:	\$ <u>51,656.00</u>
B	Grading and Drainage:	\$ <u>1,254,965.00</u> 4,230,835.00 M.S.
C	Water and Sewer:	\$ <u>170,858.00</u>
D	Electrical:	\$ <u>1,176,094.00</u>
E	Site Construction:	\$ <u>6,704,940.00</u>
F	Irrigation:	\$ <u>1,165,002.00</u>
G	Planting:	\$ <u>31,393.00</u> 31,039.00

For the total Base Bid ten mill. five hundred fifty four thousand nine hundred dollars eight dollars zero cents
 (in words) (\$ 10,554,908.00)

including all applicable taxes, permits, licenses, **AND Course of Construction Insurance.**

ALTERNATE BID ITEMS

(Add or Deduct state which)

1. Alternate Bid Synthetic Turf "FieldTurf Prestige XM50"
(refer to specifications section 02890.05 A)

\$ 190,422.00 deduct

2. Alternate Bid Synthetic Turf "Mondo Green Ecofill MF4563"
(refer to specifications section 02890.05 B)

\$ 720,000.00 add

3. Alternate Bid Synthetic Turf "Sprinturf Ultrablade DF"
(refer to specifications section 02890.05 C)

\$ 2 m.s 15,000.00 add

4. Alternate Bid Football Field
Item includes football field striping, combination football/soccer goals and steel posts and netting. Original soccer goals shall be included in the base bid.

\$ 21,000 add

5. Alternate Bid _____
(as listed by contractor)

\$ _____

6. Alternate Bid _____
(as listed by contractor)

\$ _____

7. Alternate Bid _____
(as listed by contractor)

\$ _____

8. Alternate Bid _____
(as listed by contractor)

\$ _____

9. Alternate Bid _____
(as listed by contractor)

\$ _____

10. Alternate Bid _____
(as listed by contractor)

\$ _____

And,
Cost of Contractor's Course of Construction Insurance 45,000.00 dollars (forty five thous. dollars) and deductible \$ 10,000.00 m.s

Bids must be submitted on all items (except Alternate Bid items 5-10 if not needed by contractor). Failure to bid on all items may result in the bid being rejected as non-responsive. The basis for award will be the qualified bidder with the lowest total of the Base Bid WITH COURSE OF CONSTRUCTION INSURANCE. Alternates may be awarded in any order after determination of the lowest responsible and responsive bidder.



ECONOMIC DEVELOPMENT AGENCY – COUNTY OF RIVERSIDE

ADDENDUM NO. 001

TO BIDDING DOCUMENTS, CONTRACT, BASIC SPECIFICATIONS, AND SPECIAL REQUIREMENTS
FOR
RANCHO JURUPA REGIONAL SPORTS COMPLEX

Bidders are advised that the Contract Documents for the above referenced contract are hereby amended in the following manner and in the following manner only:

A. GENERAL ITEMS

1. All provisions of this Addendum No. 001 are hereby incorporated into the contract documents, and bidders shall account for all provisions pursuant to this Addendum No. 001 in submitting their bid proposals. Each bidder shall include a dated and signed copy of this Addendum No. 001 with his sealed bid proposal.
2. Mandatory Job Walk will take place on Wednesday, October 13, 2010 at 10:00 am. The location of the job walk will be at 4800 Crestmore Road, Riverside CA 92509-6839. Follow the directional signs into the Park. The meeting location will be at the Pecan Shade Shelter.
3. Plans and specifications are available at OCB Reprographics of Riverside. Please contact them for cost of plans and specifications.

B. PLAN & SPECIFICATION ITEMS

1. Replace the following specification sections with the specifications attached.
02441, 02461, 02740, 02763, 02783, 02890, 09860, 16000
2. Add the following specification sections attached.
13000, 13120
3. Turf shall be SOD only. Remove reference to hydroseed turf on planting plans.
4. Construction Plan item 24b on sheet CP-2 shall be changed to item 24a.

www.rivcoeda.org

Administration
Aviation
Business Intelligence
Cultural Services
Community Services
Custodial

Housing
Housing Authority
Information Technology
Maintenance
Marketing

Economic Development
Edward-Dean Museum
Environmental Planning
Fair & National Date Festival
Foreign Trade
Graffiti Abatement

Porting
Project Management
Purchasing Group
Real Property
Redevelopment Agency
Workforce Development

5. Contractor shall note the requirement of providing for turnover to the County a synthetic turf sweeper and groomer as part of the base bid cost as noted on page 9 of specification section 02890.
6. Contractor shall note that the drainline shown on sheets C5 and C9 shall NOT be installed under the concrete paving as shown. Drainline shall be installed as shown on sheet TD-1.
7. The **County will provide** all site survey services. Section 8.9.1 under "LAYOUT OF WORK" shall be modified accordingly.
8. The attached "Contractor's Proposal" shall be used in place of the one in the original bid specifications.

DATED: October 7, 2010

By: _____
Jason Plotkin, Project Manager

October 7, 2010

Date Received by Bidder

By: _____
Bidder's Signature

Mark Stinnett; Senior Vice President
Typed or Printed Name

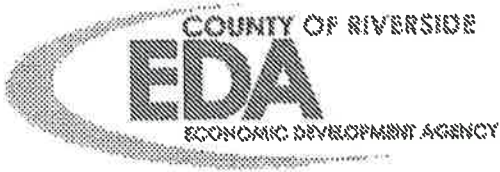

ECONOMIC DEVELOPMENT AGENCY – COUNTY OF RIVERSIDE

ADDENDUM NO. 002

TO BIDDING DOCUMENTS, CONTRACT, BASIC SPECIFICATIONS, AND SPECIAL REQUIREMENTS
FOR
RANCHO JURUPA REGIONAL SPORTS COMPLEX

Bidders are advised that the Contract Documents for the above referenced contract are hereby amended in the following manner and in the following manner only:

A. GENERAL

1. All provisions of this Addendum No. 002 are hereby incorporated into the contract documents, and bidders shall account for all provisions pursuant to this Addendum No. 002 in submitting their bid proposals. Each bidder shall include a dated and signed copy of this Addendum No. 002 with his sealed bid proposal.
2. The following Addendum No. 002 contains the job walk sign-in sheets, agenda, and answers to questions asked at the job walk.

DATED: October 13, 2010

By: _____
Jason Plotkin, Project Manager

October 13, 2010
Date Received by Bidder

By: 
Bidder's Signature

Mark Stinnett; Senior Vice President
Typed or Printed Name



ECONOMIC DEVELOPMENT AGENCY – COUNTY OF RIVERSIDE

ADDENDUM NO. 003

TO BIDDING DOCUMENTS, CONTRACT, BASIC SPECIFICATIONS, AND SPECIAL REQUIREMENTS
FOR
RANCHO JURUPA REGIONAL SPORTS COMPLEX

Bidders are advised that the Contract Documents for the above referenced contract are hereby amended in the following manner and in the following manner only:

A. GENERAL ITEMS

1. All provisions of this Addendum No. 003 are hereby incorporated into the contract documents, and bidders shall account for all provisions pursuant to this Addendum No. 003 in submitting their bid proposals. Each bidder shall include a dated and signed copy of this Addendum No. 003 with his sealed bid proposal.

B. PLAN & SPECIFICATION ITEMS

1. Add football field striping, combination football/soccer goals and steel posts and netting to the southeast synthetic turf field (Field 2). Refer to attached sheets:
"RJRSC - Revised Sheet CP-2 (addendum #3).pdf"
"RJRSC - Revised Sheet LP-2 (addendum #3).pdf"
"RJRSC - Revised Sheet CD-4 (addendum #3).pdf"
2. Revise soccer goals on Fields 5 and 6 per attached sheet:
"RJRSC - Revised Sheet CP-2 (addendum #3).pdf".
3. Note locations of playground gravel sumps added to detail 'A' on attached sheet:
"RJRSC - Revised Sheet CD-2 (addendum #3).pdf".
4. Change Ackerstone paver color to "Charcoal Brown Buff" as shown on attached sheet:
"RJRSC - Revised Sheet CP-2 (addendum #3).pdf"

5. Replace specification Section 02890 – Synthetic Turf with the attached file:
"02890 - SYNTHETIC TURF SYSTEM (rev for Addendum #3).pdf"

Note change to 02890.06 item 2:

2. In the event that the Prime Contractor does not meet these requirements, a sub-contractor may be listed that does meet the requirements specified in item 1 above. The Prime Contractor shall provide evidence of experience by the listed sub-contractor in preparing drainage base systems for synthetic turf and the sub-contractor must have installed a minimum of 10 sub-grade drainage base systems for synthetic turf playing fields in the past 3 years in California.

6. Replace the Contractor's Proposal with the attached file:
"RJRSC Contractor's Proposal - Addendum #3 (10-15-10).pdf"

DATED: October 15, 2010

By: _____
Jason Plotkin, Project Manager

October 15, 2010
Date Received by Bidder

By: 
Bidder's Signature

Mark Stinnett; Senior Vice President
Typed or Printed Name



ECONOMIC DEVELOPMENT AGENCY – COUNTY OF RIVERSIDE

ADDENDUM NO. 004

TO BIDDING DOCUMENTS, CONTRACT, BASIC SPECIFICATIONS, AND SPECIAL REQUIREMENTS
FOR
RANCHO JURUPA REGIONAL SPORTS COMPLEX

Bidders are advised that the Contract Documents for the above referenced contract are hereby amended in the following manner and in the following manner only:

A. GENERAL ITEMS

1. All provisions of this Addendum No. 004 are hereby incorporated into the contract documents, and bidders shall account for all provisions pursuant to this Addendum No. 004 in submitting their bid proposals. Each bidder shall include a dated and signed copy of this Addendum No. 004 with his sealed bid proposal.
2. The cutoff for RFI's has changed to **Thursday, October 21, 2010 at 2:30pm**

B. PLAN & SPECIFICATION ITEMS

1. Change the play equipment model number in the construction legend items "D" and "E" on detail "A" sheet CD-2, to 31360-1-2.
2. Specification Section 13000.F.1. shall be changed to "The **OWNER** is responsible for the site survey and staking the building location,"
3. The quantity of picnic tables on CP-1 and CP-2, item 16 shall be changed to **52**.
4. The retaining walls located along the north property line shall be constructed per detail H, sheet C2 as indicated on sheets C3 and C4. The retaining walls located on the north and west sides of the soccer field adjacent to the concrete paving shall be constructed per details A and D, sheet CD-3 as indicated on sheet CP-2.
5. Detail A and D on sheet CD-3 show a typical mow curb against wall, where turf occurs. It then references detail F, on CD-1 which is the monument sign, which is incorrect. A mow curb detail has been included as part of this addendum.

6. Specification Section 02890.08 Field Conditions **Part A** shall be removed from the specifications.
7. The contractor shall be required to prepare the Storm Water Pollution Prevention Plan (SWPPP) for the project. The SWPPP shall meet all requirements of the **2009-0009-DWQ Construction general permit** which can be found at:
http://www.swrcb.ca.gov/water_issues/programs/stormwater/constpermits.shtml
8. The connection to the existing flood control down drain shall be made utilizing a concrete collar in accordance with APWA STD 380-4.
9. The electrical plan sheets (E-1, E-2, E-3, E-4, E-5, E-6, E-7, E-8, E-9, E-10) dated 5/10/10 shall be replaced with the attached sheets dated 5/27/10. Information missing from the original sheets has been added.
10. All work within 5' of the synthetic turf system, both above and below ground, must be performed by a qualified contractor according to the project specifications. Pre-qualifications shall be submitted for the synthetic field installers **AND** sub-drain and crushed rock preparation installers. The pre-qualifications can be submitted **within 24 hours after the bid opening by the three apparent low bidders**.
11. The 15" drain line indicated on sheet C9 should be revised to the 18" perforated drain as indicated within the specs. The 48" perforated drain line adjacent to the parking lot is the infiltration trench drain for water quality purposes and is considered to be part of the perimeter drain system for the synthetic turf fields. In addition, all drain inlets and laterals that connect to the perimeter drain system are considered part of the synthetic turf sub-drainage system and must be installed by a qualified sub-drainage subcontractor with 10 fields in 3 years experience per the project specifications. The connections must be made to 5' outside of the trench/synthetic turf area where a qualified underground utility contractor may pick up the connection and install the rest of the upstream system.
12. The sidewalk that is referred to in detail C sheet C-3 is the public sidewalk within the County right-of-way that is indicated on the SP sheets. This sidewalk per County standard is a 4" thick sidewalk. Interior sidewalks (outside of the R/W) shall be 6" thick per the CP sheets.
13. Sheets C7 and C11 were labeled incorrectly; the scale of these sheets is 1"=30'.
14. Wire note #1 on sheet IP-1 specifies "All valve control / common wires shall be installed in a schedule 40 gray PVC conduit per detail "B" sheet ID-1". The detail reference should be **detail "I" sheet ID-1**. All common, pilot and spare wires shall be installed inside schedule 40 PVC grey conduit in a **continuous route** from controllers to all the remote control valve locations.
15. The pipe for all drinking fountain lines shall be schedule 40 PVC.
16. All 6" irrigation pipe shall be Class 200 PVC Ring-Tite.

- 17. The exterior of the trash enclosure walls shall have a stone veneer wainscot to match the electrical enclosure on detail "E" sheet CD-2.
- 18. Refer to Stone Veneer Column detail included in Addendum #4 for detail on stone veneer columns at the shade structure posts.

DATED: October 20, 2010

October 20, 2010
Date Received by Bidder

By: _____
Jason Plotkin, Project Manager

By:  _____
Bidder's Signature

Mark Stinnett; Senior Vice President
Typed or Printed Name



ECONOMIC DEVELOPMENT AGENCY – COUNTY OF RIVERSIDE

ADDENDUM NO. 005

TO BIDDING DOCUMENTS, CONTRACT, BASIC SPECIFICATIONS, AND SPECIAL REQUIREMENTS
FOR
RANCHO JURUPA REGIONAL SPORTS COMPLEX

Bidders are advised that the Contract Documents for the above referenced contract are hereby amended in the following manner and in the following manner only:

A. GENERAL ITEMS

1. All provisions of this Addendum No. 005 are hereby incorporated into the contract documents, and bidders shall account for all provisions pursuant to this Addendum No. 005 in submitting their bid proposals. Each bidder shall include a dated and signed copy of this Addendum No. 005 with his sealed bid proposal.

B. PLAN & SPECIFICATION ITEMS

1. All concrete paving shall be 3,250 psi per plans. The reference to 4,000 psi concrete in the Geotechnical Report shall be revised to 3,250 psi.
2. Detail 'C', Sheet CD-3 shall be modified to have the gravel base and geotextile fabric extend 18" beyond the edge of the concrete pavers.
3. Construct a 6" wide by 16" deep concrete curb to separate the asphalt paving and permeable pavers. Install continuous #4 rebar 3" below top of curb and 1" deep score joints at 10' O.C. The top of curb is to be flush with the adjacent pavers and asphalt paving.
4. The existing stump and tree along Loring Ranch are to be removed.
5. The reference to hydroseed turf on sheets PP-1 and PP-2 shall be removed. The base bid shall be sod turf as specified on the plans.
6. The alternate bid item for the football striping shall also include increasing the length of the synthetic turf blades to a minimum of 2.5".

DATED: October 22, 2010

October 22, 2010
Date Received by Bidder

By: _____
Jason Plotkin, Project Manager

By:  _____
Bidder's Signature

Mark Stinnett; Senior Vice President
Typed or Printed Name

AWARD OF CONTRACT

The undersigned fully understands that a Contract is formed upon the acceptance of this Proposal by the Owner and the undersigned further agrees that upon request he will promptly execute and deliver to Owner a written memorial of the Contract together with the required Payment and Performance Bonds and proof of insurance.

BID GUARANTEE

The enclosed certified or cashier's check or bidder's bond on approved form, made payable to the Owner in the amount of ten percent of the total bid submitted herewith, is hereby given as a guarantee that the bidder will execute and deliver the above mentioned written memorial and required bonds and insurance if awarded the contract, and in the event that the undersigned fails or refuses to execute and deliver said documents, such check or bond is to be charged with the costs of the damages experienced by the Owner as a result of such failure or refusal, including but not limited to publication costs, the difference in money between the amount of the bid of the said principal and the amount for which obligee may legally contract with another party to perform the said work if such amount be in excess of the former, building lease or rental costs, transportation costs and additional salary costs that result from the delay due to the principal's default on the awarded contract. In no event, however, shall the Surety's liability exceed the penal sum hereof.

Name of Bidder: EDGE Development, Inc.
Type of Organization: Corporation
Signed By: Mark Stinnett
Title of Signer: Senior Vice President
Address of Bidder: 27368 Via Industria; Suite 101
Temecula, CA 92590

Telephone No.: 951-296-0776
Contractor's License No.: 723993
Classification: A, B, C-8 Expiration Date: 06/30/2012

Affix Seal
If
Corporation

LICENSURE STATEMENTS ARE MADE UNDER PENALTY OF PERJURY

If bidder is a corporation, and signer is not President or Secretary, attach a certified copy of By-Laws or resolution authorizing execution. If bidder is a corporation, affix corporate seal. If signer is an agent, attach Power of Attorney. If bidder is not an individual, list names of other persons authorized to bind the organization.

**NONCOLLUSION AFFIDAVIT TO BE EXECUTED BY BIDDER AND
SUBMITTED WITH BID**

State of California) ss.
County of Riverside)

Mark Stinnett, being first duly sworn, deposes and says:

That he or she is Senior Vice President of EDGE Development, Inc.
the party making the foregoing bid; that the bid is not made in the interest of, or on behalf of, any undisclosed person, partnership, company, association, organization, or corporation; that the bid is genuine and not collusive or sham; that the bidder has not directly or indirectly induced or solicited any other bidder to put in a false or sham bid, and has not directly or indirectly colluded, conspired, connived, or agreed with any bidder or anyone else to put in a sham bid, or that anyone shall refrain from bidding; that the bidder has not in any manner, directly or indirectly, sought by agreement, communication, or conference with anyone to fix the bid price of the bidder or any other bidder, or to fix any overhead, profit, or cost element of the bid price, or of that of any other bidder, or to secure any advantage against the public body awarding the contract of anyone interested in the proposed contract; that all statements contained in the bid are true; and, further, that the bidder has not, directly or indirectly, submitted his or her bid price or any breakdown thereof, or the contents thereof, or divulged information or data relative thereto, or paid, and will not pay, any fee to any corporation, partnership, company association, organization, bid depository, or to any member or agent thereof to effectuate a collusive or sham bid.

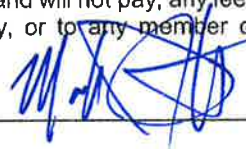

Signature

Subscribed and sworn to before me this 21st day of October, 2010

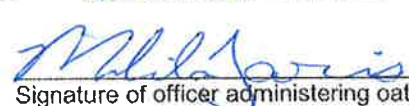

Signature of officer administering oath



Bid Bond

KNOWN TO ALL MEN BY THESE PRESENTS, that we, the undersigned EDGE Development, Inc., as Principal; and Safeco Insurance Company of America, as Surety, are hereby held and firmly bound unto the Redevelopment Agency for the County of Riverside, hereinafter called the "Owner", in the sum of ten percent of the bid amount Dollars (\$ 10% of the bid) for the payment of such sum, well and truly to be made, do hereby jointly and severally bind ourselves, our heirs, executors, administrators, successors and assigns.

WHEREAS, the said Principal is herewith submitting its Proposal for the Rancho Jurupa Regional Sports Complex

THE CONDITION OF THE ABOVE OBLIGATION IS SUCH, that if the aforesaid Principal shall be awarded the Contract upon said Proposal and shall, within the required number of days after the notice of such award, execute a written memorial of the awarded Contract and submit the required Labor and Material Payment and faithful Performance Bond and proof of insurance, then this obligation shall be null and void; and in the event that the Principal falls and/or refuses to execute and deliver said documents this Bond will be charged with the costs of the damages experienced by the Owner as a result of such refusal, including but not limited to, publication cost, the difference in money between the amount of the bid of the said Principal and the amount for which the obligee may legally contract with another party to perform the said work if such amount be in excess of the former; building lease or rental costs, transportation cost, and additional salary costs that result from the delay due to the Principal's default on the awarded Contract. In no event however, shall the Surety's liability exceed the penal sum hereof.

The Surety, for value received, hereby stipulates and agrees that the obligations of said Surety and its bond shall be in no way impaired or affected by any extension of the time within which the Owner may accept such bid; and said Surety does hereby waive notice of any such extension.

IN WITNESS WHEREOF, the above bounded parties have executed this instrument under their separate seals this 19th day of October, 2010, the name and corporate seal of each corporate party being herelo affixed and those present duly signed by its undersigned representative, pursuant to authority of its governing body.

EDGE Development, Inc.

(Firm Name - Principal)

27368 Via Industria, Suite 101, Temecula, CA 92590

(Business Address)

By 

(Original Signature)

CEO/Secretary, K. Dayne Wagoner

(Title)

Safeco Insurance Company of America

(Corporation Name - Surety)

330 North Brand Blvd., Suite 550, Glendale, CA 91207

(Business Address)

By 

(Original Signature) Janina Monroe, Attorney-In-Fact

Affix Seal
If
Corporation

Affix
Corporate
Seal

State of California)
County of Riverside)

CALIFORNIA ALL-PURPOSE CERTIFICATE OF ACKNOWLEDGMENT

On Oct 21, 2010 before me, Melinda Jarvis, a Notary Public, personally appeared, K. Dayne Waggoner, who proved to me on the basis of satisfactory evidence to be the person(s) whose name(s) is/are subscribed to the within instrument and acknowledged to me that he/she/they executed the same in his/her/their authorized capacity(ies), and that by his/her/their signature(s) on the instrument the person(s), or the entity upon behalf of which the person(s) acted, executed the instrument.

I certify under PENALTY OF PERJURY under the laws of the State of California that the foregoing paragraph is true and correct.

WITNESS my hand and official seal.



Signature Melinda Jarvis

(Seal)

OPTIONAL INFORMATION

Although the information in this section is not required by law, it could prevent fraudulent removal and reattachment of this acknowledgment to an unauthorized document and may prove useful to persons relying on the attached document.

Description of Attached Document

The preceding Certificate of Acknowledgment is attached to a document titled/for the purpose of _____ containing _____ pages, and dated _____.

The signer(s) capacity or authority is/are as:

- Individual(s)
- Attorney-in-Fact
- Corporate Officer(s) _____ Title(s)

- Guardian/Conservator
- Partner - Limited/General
- Trustee(s)
- Other: _____

representing: _____
Name(s) of Person(s) or Entity(ies) Signer is Representing

Additional Information	
Method of Signer Identification	
<input type="checkbox"/>	Personally known to me
<input type="checkbox"/>	Proved to me on the basis of satisfactory evidence: <input type="radio"/> form(s) of identification <input type="radio"/> credible witness(es)
Identification is detailed in notary journal on: Page # _____ Entry # _____	
Notary contact: _____	
Other	
<input type="checkbox"/>	Additional Signer(s)
<input type="checkbox"/>	Signer(s) Thumbprint(s)
<input type="checkbox"/>	_____

CALIFORNIA ALL-PURPOSE ACKNOWLEDGMENT

STATE OF CALIFORNIA

County of Orange }

On OCT 19 2010 before me, Michelle Haase, Notary Public
Date Here Insert Name and Title of the Officer

personally appeared Janina Monroe
Name(s) of Signer(s)

who proved to me on the basis of satisfactory evidence to be the person(s) whose name(s) is/are subscribed to the within instrument and acknowledged to me that he/she/they executed the same in his/her/their authorized capacity(ies), and that by his/her/their signature(s) on the instrument the person(s), or the entity upon behalf of which the person(s) acted, executed the instrument.

I certify under PENALTY OF PERJURY under the laws of the State of California that the foregoing paragraph is true and correct.

Witness my hand and official seal.

Signature Michelle Haase
Signature of Notary Public



Place Notary Seal Above

OPTIONAL

Though the information below is not required by law, it may prove valuable to persons relying on the document and could prevent fraudulent removal and reattachment of this form to another document.

Description of Attached Document

Title or Type of Document: _____

Document Date: _____ Number of Pages: _____

Signer(s) Other Than Named Above: _____

Capacity(ies) Claimed by Signer(s)

Signer's Name: _____

- Individual
- Corporate Officer — Title(s): _____
- Partner — Limited General
- Attorney in Fact
- Trustee
- Guardian or Conservator
- Other: _____



Signer Is Representing: _____

Signer's Name: _____

- Individual
- Corporate Officer — Title(s): _____
- Partner — Limited General
- Attorney in Fact
- Trustee
- Guardian or Conservator
- Other: _____



Signer Is Representing: _____



POWER OF ATTORNEY

Safeco Insurance Company of America
General Insurance Company of America
1001 4th Avenue
Suite 1700
Seattle, WA 98154

No. 11614

KNOW ALL BY THESE PRESENTS:

That SAFECO INSURANCE COMPANY OF AMERICA and GENERAL INSURANCE COMPANY OF AMERICA, each a Washington corporation, does each hereby appoint

*****PAUL BOUCHER; LEONARD G. FODEMSKI; JANINA MONROE; TIMOTHY J. NOONAN; SUSAN THURSTON; Los Angeles, California*****

its true and lawful attorney(s)-in-fact, with full authority to execute on its behalf fidelity and surety bonds or undertakings and other documents of a similar character issued in the course of its business, and to bind the respective company thereby.

IN WITNESS WHEREOF, SAFECO INSURANCE COMPANY OF AMERICA and GENERAL INSURANCE COMPANY OF AMERICA have each executed and attested these presents

this 21st day of March 2009

Dexter R. Legg (handwritten signature)

TAMIKOLAJEWSKI (handwritten signature)

Dexter R. Legg, Secretary

Timothy A. Mikolajewski, Vice President

CERTIFICATE

Extract from the By-Laws of SAFECO INSURANCE COMPANY OF AMERICA and of GENERAL INSURANCE COMPANY OF AMERICA:

"Article V, Section 13. - FIDELITY AND SURETY BONDS ... the President, any Vice President, the Secretary, and any Assistant Vice President appointed for that purpose by the officer in charge of surety operations, shall each have authority to appoint individuals as attorneys-in-fact or under other appropriate titles with authority to execute on behalf of the company fidelity and surety bonds and other documents of similar character issued by the company in the course of its business... On any instrument making or evidencing such appointment, the signatures may be affixed by facsimile. On any instrument conferring such authority or on any bond or undertaking of the company, the seal, or a facsimile thereof, may be impressed or affixed or in any other manner reproduced; provided, however, that the seal shall not be necessary to the validity of any such instrument or undertaking."

Extract from a Resolution of the Board of Directors of SAFECO INSURANCE COMPANY OF AMERICA and of GENERAL INSURANCE COMPANY OF AMERICA adopted July 28, 1970.

"On any certificate executed by the Secretary or an assistant secretary of the Company setting out,

- (i) The provisions of Article V, Section 13 of the By-Laws, and
(ii) A copy of the power-of-attorney appointment, executed pursuant thereto, and
(iii) Certifying that said power-of-attorney appointment is in full force and effect,

the signature of the certifying officer may be by facsimile, and the seal of the Company may be a facsimile thereof."

I, Dexter R. Legg, Secretary of SAFECO INSURANCE COMPANY OF AMERICA and of GENERAL INSURANCE COMPANY OF AMERICA, do hereby certify that the foregoing extracts of the By-Laws and of a Resolution of the Board of Directors of these corporations, and of a Power of Attorney issued pursuant thereto, are true and correct, and that both the By-Laws, the Resolution and the Power of Attorney are still in full force and effect.

IN WITNESS WHEREOF, I have hereunto set my hand and affixed the facsimile seal of said corporation

this OCT 19 2010 day of



Dexter R. Legg (handwritten signature)

Dexter R. Legg, Secretary

EDGE DEVELOPMENT, INC.

a California corporation

**ACTIONS BY BOARD OF DIRECTORS
WITHOUT A MEETING
BY UNANIMOUS WRITTEN CONSENT
(Annual Board of Directors Meeting)**

Pursuant to the California Corporations Code and the Bylaws of Edge Development, Inc., (“Corporation”) the undersigned, being all of the Directors of the Corporation, unanimously authorize and consent to the following resolutions and actions of the Board of Directors, without a meeting of the Directors of the Corporation:

WHEREAS, the undersigned Directors are desirous of electing Officers in accordance with the annual Board of Directors meeting procedures of the Corporation;

IT IS, THEREFORE, RESOLVED, the following individuals are elected to the specified position opposite their names and shall serve until the next annual meeting of the Directors of the Corporation, or until their successors are duly elected and qualified;

<u>Name</u>	<u>Office</u>
K. Dayne Wagoner	Chief Executive Officer and Secretary
Stephen S. Prophet	Chief Operations Officer and President
Kathi A. Richards	Chief Financial Officer
Stephen D. Rogers	Executive Vice President
Al Calvet	Senior Vice President
Mark Stinnett	Senior Vice President

WHEREAS, the undersigned Directors are desirous of confirming the state of affairs of the Corporation and its activities since the last annual meeting of the Directors;

IT IS, THEREFORE, RESOLVED, all actions of the Officers of the Corporation subsequent to the last annual meeting of the Directors are hereby affirmed, ratified and approved.

DATED: March 22, 2010



Kenneth D. Wagoner, Director



Stephen S. Prophet, Director



Submittals Required at time of Bid (Information Required of Bidder)

Rancho Jurupa Regional Sports Complex

1. Proof of reference sites with structures for similar scope of project and installation that are engineered to CBC. Include in reference list install dates and project locations:

Joined Cantilevers (2007) Ralph M. Lewis Park – Fontana, CA
Joined Luna /Joined Eclipse structures (2008) – Ontario Sports Complex, Ontario, CA
Joined Hypar Sails (2009) – El Cerrito Park, Corona, CA

2. Please find fabric samples and Powder Coat chart to demonstrate fabric color and powder coat color range. In addition, find letter of authorization from fabric manufacturer for use of fabric.

3. Quality Assurance Items:
 - 3 Reference Sites:
 - Vasquez High School – Acton/Agua Dulce USD – 1999
 - Ray Wiltsey Middle School – Ontario Montclair SD – 1999
 - Hawes Elementary School – Huntington Beach City School District – 1999

 - Please find attached documentation of proof of Liability Insurance and Umbrella Insurance.
 - Please find attached documentation of proof of current CA Contractors License
 - Proof of minimum \$7,000,000 bonding capacity with an A-Class Certified Surety.
 - Please find attached documentation of proof of IAS (International Accreditation Service) certification.
 - Please find attached documentation of proof of Corporate Quality Control Manual
 - Please find attached documentation of proof of Safety Program with Injury & Illness Prevention Program
 - Please find attached documentation of proof of Annual Maintenance Inspection Program and Maintenance Training.



Corporate Headquarters
 8505-A Chancellor Row, Dallas, TX 75247
 P 214.905.9500 F 214.905.9514 TF 800.966.5005



West Coast Headquarters
 350 Kalmus Drive, Costa Mesa, CA 92626
 P 714.427.6981 F 714.427.6982 TF 800.50.SHADE

Shadesure® Fabric

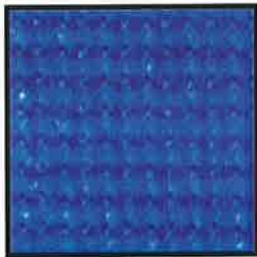

Royal Blue
 Shade Factor 90%
 UV Factor 94%



Laguna Blue
 Shade Factor 90%
 UV Factor 93%

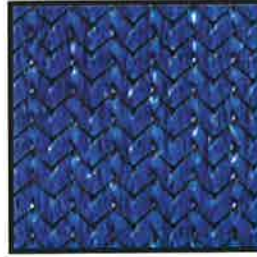

Navy Blue
 Shade Factor 90%
 UV Factor 94%

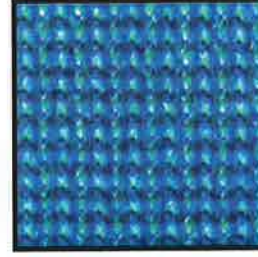

Turquoise
 Shade Factor 83%
 UV Factor 92%



Rain Forest
 Shade Factor 88%
 UV Factor 95%



Arizona
 Shade Factor 81%
 UV Factor 93%



Black
 Shade Factor 95%
 UV Factor 96%

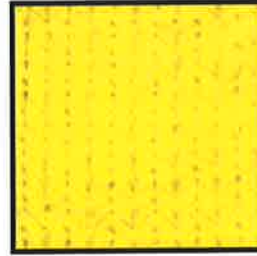

Sunflower Yellow
 Shade Factor 70%
 UV Factor 94%



Desert Sand
 Shade Factor 75%
 UV Factor 95%



Terra-cotta
 Shade Factor 82%
 UV Factor 88%



White
 Shade Factor 50%
 UV Factor 85%



Silver
 Shade Factor 88%
 UV Factor 93%



Red
 Shade Factor 78%
 UV Factor 88%



Shadesure® fabrics carry a 10 year limited manufacturers warranty* from the date of installation against failure from significant fading, deterioration, breakdown, mildew, outdoor heat, cold or discoloration, with the exception of Red and Coolbrella fabrics which carry a 3 year limited warranty.

(Fabric colors may vary slightly based on the media of which this flyer is printed out on or distributed as pdf.)



BRANDS YOU KNOW, STRUCTURES YOU TRUST

A Division of Multiknit (Pty) Ltd
Registration No. 2005/001840/07
VAT Registration No. 4460230123
5 Theo Kleyrhans Street, White River 1240, South Africa
P O Box 798, White River, 1240, South Africa
Tel: 27 13 751-2376
Fax: 27 13 751-3221
E-mail: exports@multiknit.co.za
Web address: www.multiknit.com

30 October 2008

TO WHOM IT MAY CONCERN

USA Shade and Fabric Structures is an authorised distributor and fabricator of Multiknit fabrics, also known as Shadesure® and Colourshade®, in the United States. As such, they are authorised to market, specify, procure, fabricate and install our products in the Shade business industry.

Yours sincerely,



Robin Card
Export Sales Executive

ACORDTM CERTIFICATE OF LIABILITY INSURANCE

DATE (MM/DD/YYYY)

8/30/2010

PRODUCER Phone: 817-299-3800 Fax: 817-299-3890
 IBTX Risk Services Hurst
 8701 Bedford Eules Rd., #450
 Hurst TX 76053

THIS CERTIFICATE IS ISSUED AS A MATTER OF INFORMATION ONLY AND CONFERS NO RIGHTS UPON THE CERTIFICATE HOLDER. THIS CERTIFICATE DOES NOT AMEND, EXTEND OR ALTER THE COVERAGE AFFORDED BY THE POLICIES BELOW.

INSURERS AFFORDING COVERAGE

NAIC #

INSURER A: Continental Casualty Co	20443
INSURER B: Valley Forge Insurance Compan	20508
INSURER C: National Fire Insurance of Ha	20478
INSURER D: GOTHAM INS CO	25569
INSURER E:	

INSURED
 USA Shade & Fabric Structures, Inc.
 P.O. Box 560168
 Dallas TX 75356

COVERAGES

THE POLICIES OF INSURANCE LISTED BELOW HAVE BEEN ISSUED TO THE INSURED NAMED ABOVE FOR THE POLICY PERIOD INDICATED. NOTWITHSTANDING ANY REQUIREMENT, TERM OR CONDITION OF ANY CONTRACT OR OTHER DOCUMENT WITH RESPECT TO WHICH THIS CERTIFICATE MAY BE ISSUED OR MAY PERTAIN, THE INSURANCE AFFORDED BY THE POLICIES DESCRIBED HEREIN IS SUBJECT TO ALL THE TERMS, EXCLUSIONS AND CONDITIONS OF SUCH POLICIES. AGGREGATE LIMITS SHOWN MAY HAVE BEEN REDUCED BY PAID CLAIMS.

INSR ADD'L LTR INSRD	TYPE OF INSURANCE	POLICY NUMBER	POLICY EFFECTIVE DATE (MM/DD/YY)	POLICY EXPIRATION DATE (MM/DD/YY)	LIMITS	
B	GENERAL LIABILITY <input checked="" type="checkbox"/> COMMERCIAL GENERAL LIABILITY <input type="checkbox"/> CLAIMS MADE <input checked="" type="checkbox"/> OCCUR GEN'L AGGREGATE LIMIT APPLIES PER: <input type="checkbox"/> POLICY <input checked="" type="checkbox"/> PROJECT <input type="checkbox"/> LOC	CPP2091508209	8/29/2010	8/29/2011	EACH OCCURRENCE	\$ 1,000,000
					DAMAGE TO RENTED PREMISES (Ea occurrence)	\$200,000
					MED EXP (Any one person)	\$ 15,000
					PERSONAL & ADV INJURY	\$ 1,000,000
					GENERAL AGGREGATE	\$ 2,000,000
					PRODUCTS - COMP/OP AGG	\$ 2,000,000
C	AUTOMOBILE LIABILITY <input checked="" type="checkbox"/> ANY AUTO <input type="checkbox"/> ALL OWNED AUTOS <input type="checkbox"/> SCHEDULED AUTOS <input checked="" type="checkbox"/> HIRED AUTOS <input checked="" type="checkbox"/> NON-OWNED AUTOS	CA2091508212	8/29/2010	8/29/2011	COMBINED SINGLE LIMIT (Ea accident)	\$ 1,000,000
					BODILY INJURY (Per person)	\$
					BODILY INJURY (Per accident)	\$
					PROPERTY DAMAGE (Per accident)	\$
	GARAGE LIABILITY <input type="checkbox"/> ANY AUTO				AUTO ONLY - EA ACCIDENT	\$
					OTHER THAN AUTO ONLY: EA ACC	\$
					AGG	\$
A	EXCESS/UMBRELLA LIABILITY <input checked="" type="checkbox"/> OCCUR <input type="checkbox"/> CLAIMS MADE <input type="checkbox"/> DEDUCTIBLE <input checked="" type="checkbox"/> RETENTION \$ \$10,000	CU2091508243	8/29/2010	8/29/2011	EACH OCCURRENCE	\$ 10,000,000
					AGGREGATE	\$ 10,000,000
						\$
						\$
						\$
B	WORKERS COMPENSATION AND EMPLOYERS' LIABILITY ANY PROPRIETOR/PARTNER/EXECUTIVE OFFICER/MEMBER EXCLUDED? If yes, describe under SPECIAL PROVISIONS below	WC2091508226	8/29/2010	8/29/2011	<input checked="" type="checkbox"/> WC STATUTORY LIMITS	OTHER
B		WC2089224285 - CA	8/29/2010	8/29/2011	E.L. EACH ACCIDENT	\$ 1,000,000
					E.L. DISEASE - EA EMPLOYEE	\$ 1,000,000
					E.L. DISEASE - POLICY LIMIT	\$ 1,000,000
D	OTHER Professional Liability	P10152510	8/29/2010	8/29/2011	\$3,000,000 \$3,000,000 Claims Made; Retro Date:	Occurrence Aggregate Ded.: \$25,000 06/01/2007

DESCRIPTION OF OPERATIONS / LOCATIONS / VEHICLES / EXCLUSIONS ADDED BY ENDORSEMENT / SPECIAL PROVISIONS
 10 Day Notice of Cancellation applies for non-payment of premium

CERTIFICATE HOLDER

Sample

CANCELLATION 30

SHOULD ANY OF THE ABOVE DESCRIBED POLICIES BE CANCELLED BEFORE THE EXPIRATION DATE THEREOF, THE ISSUING INSURER WILL ENDEAVOR TO MAIL 30* DAYS WRITTEN NOTICE TO THE CERTIFICATE HOLDER NAMED TO THE LEFT, BUT FAILURE TO DO SO SHALL IMPOSE NO OBLIGATION OR LIABILITY OF ANY KIND UPON THE INSURER, ITS AGENTS OR REPRESENTATIVES.

AUTHORIZED REPRESENTATIVE

Joseph Clayborne

IMPORTANT

If the certificate holder is an ADDITIONAL INSURED, the policy(ies) must be endorsed. A statement on this certificate does not confer rights to the certificate holder in lieu of such endorsement(s).

If SUBROGATION IS WAIVED, subject to the terms and conditions of the policy, certain policies may require an endorsement. A statement on this certificate does not confer rights to the certificate holder in lieu of such endorsement(s).

DISCLAIMER

The Certificate of Insurance on the reverse side of this form does not constitute a contract between the issuing insurer(s), authorized representative or producer, and the certificate holder, nor does it affirmatively or negatively amend, extend or alter the coverage afforded by the policies listed thereon.



State Of California
CONTRACTORS STATE LICENSE BOARD
ACTIVE LICENSE



License Number **851280**

Entity **CORP**

Business Name **U S A SHADE & FABRIC
STRUCTURES INC**

Classification(s) **B**

Expiration Date **12/31/2010**





IBTX Risk Services

Safety Management • Human Resources Services • Business Insurance • Personal Insurance
Employee Benefits • Surety Bonds • Wealth Management • Executive Planning

February 3, 2010

Jeff Sarembock
USA Shade & Fabric Structures, Inc.
P.O. Box 560168
Dallas, TX 75356

RE: Contact Surety Program

Dear Jeff,

Underwriters for Continental Casualty Company and Western Surety Company, collectively known as CNA Surety have authorized me to write this letter.

Subject to routine underwriting criteria, the CNA Surety companies have issued a \$5,000,000 single job, \$20,000,000 aggregate bonded backlog program for your company. This program is meant to handle the routine contract surety requests that your firm may present. This program is not the maximum size single or aggregate amount that would be approved but is merely the level at which further approvals must be sought.

You are welcome to use this letter in your firm's marketing efforts and those parties who may need further clarification are invited to contact me.

Sincerely,

Michael Hendrickson
Attorney-In-Fact

International Accreditation Service

CERTIFICATE OF ACCREDITATION

This is to signify that

**USA SHADE & FABRIC STRUCTURES, INC. AND WHOLLY OWNED SUBSIDIARIES
SHADE MANUFACTURING, INC. AND SHADE AMERICA, INC.**

8319 CHANCELLOR ROW
DALLAS, TEXAS 75247

Fabricator Inspection Program FA-428

has demonstrated that its in plant inspection program for structural steel fabrication is in compliance with the International Accreditation Service, Inc., Accreditation Criteria for Fabricator Inspection Programs for Structural Steel (AC172) and is recognized under Section 1704.2.2 of the 2000, 2003 or 2006 *International Building Code*®, commencing February 23, 2009.

Accreditation covers inspections conducted in accordance with the fabricator's approved quality control manual and the requirements of AC172. Periodic inspections are conducted by Bucher, Willis and Ratliff Corporation (AA-586), at 8319 Chancellor Row Dallas, TX 75247, to monitor fabrication inspection processes for structural steel welding. Accreditation is limited to inspections related to the fabrication processes and procedures only. Accreditation does not cover the product, the design or the performance characteristics of fabricated products.

Patrick V. McCullen

Patrick V. McCullen
Vice President

C. P. Ramani

C. P. Ramani, P.E.
President

Print Date: 08/07/2009

This accreditation certificate supersedes any IAS accreditation certificate bearing an earlier date. The certificate becomes invalid upon suspension, cancellation, revocation, or expiration of accreditation. See the IAS Accreditation Listings on the web at www.iasonline.org for current accreditation information, or contact IAS directly at (562) 695-0541.

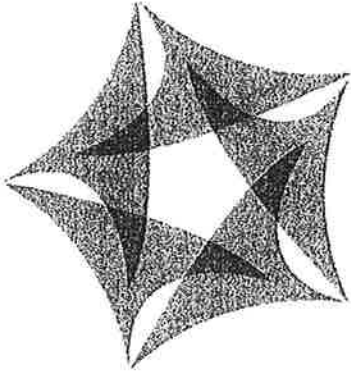

USASHADE **& Fabric Structures, Inc.**

SAFETY PROGRAM



All content © 2006 USA Shade & Fabric Structures, Inc.

USA Shade and Fabric Structures, Inc.

**INJURY & ILLNESS
PREVENTION
PROGRAM**



USASHADE
& Fabric Structures, Inc.

Shade Structure Maintenance Manual

The following Manual contains the following information;

1. Warranty Claims and Questions	1
2. Preliminary Check list Warranty/ Non Warranty	2
3. Tools and Supplies	3
4. 2-4 year Minor Repair/Maintenance for Powder Coat (Light Rust and Painting) <u>Recommended for every 2-4 years</u>	4-5
5. 20 year Major Repair/Maintenance for Powder Coat (Heavy Rust and Painting) <u>Recommended only for severe environment conditions or every 20 years</u>	6
6. Personal Protection and First Aid	7
7. Fabric Minor Repair	8
8. Fabric Maintenance	8

Annotation: These instructions are intended for the use of maintaining and/or repairing Shade Structures. Out door Shade Structures experience light to harsh environment conditions depending on their geographical location and require preventative maintenance. USA SHADE & Fabric Structures, Inc. provides a 1 year limited warranty with all of our powder coated products. Once past that warranty period, it is the consumers' responsibility to ensure the maintenance of the shade structure. As with all things metal and painted; metal requires maintenance and repair to extend the life and aesthetic appeal through out the life of the Shade Structure. These instructions are a helpful guide only and USA SHADE & Fabric Structures, Inc. do not guarantee or take the responsibility of the recommended products for warrantee or otherwise. Always follow the manufacturers' recommendations and all safety precautions to avoid injury. Thank you for purchasing our products and should you feel the need to call then feel free at Phone: 214.905.9500 Fax: 214.905.9514 Toll-Free: 800.966.5005.

1. WARRANTY CLAIMS

If you require information or assistance in preparing a claim covered by our warranty, please advise us immediately:

CLAIMS DEPARTMENT
USA SHADE & Fabric Structures, Inc.
TF: 800-966-5005 P: 214.905.9500 F: 214.905.9514
8505 Chancellor Row
Dallas, TX 75247

EMAIL ADDRESS: INFO@USA-SHADE.COM

Corporate Headquarters 8505 Chancellor Row Dallas, TX 75247
Phone: 214.905.9500 Fax: 214.905.9514 Toll-Free: 800.966.5005
West Coast Headquarters 350 Kalmus Drive Costa Mesa, CA 92626
Phone: 714.427.6981 Fax: 714.427.6982 Toll-Free: 800.507.4233

www.usa-shade.com

No part of this Instruction Manual, or any other USA SHADE & Fabric Structures, Inc. produced materials, may be reproduced, transmitted, transcribed, stored in a retrieval system, or translated into any language (natural or binary), in any form or by any means, without the expressed written consent of USA SHADE & Fabric Structures, Inc. Information contained within this document is subject to change without notice, and does not represent any commitment on the part of USA SHADE & Fabric Structures, Inc.



EDGE



Integrity • Dedication • Client Excellence

*27368 Via Industria, Suite 101
Temecula, CA 92590*

**Rancho Jurupa Regional Sports
Complex**

Clerk to the Board of Supervisors
County Administrative Center
4080 Lemon Street
Riverside, CA 92501

Bids: October 25, 2010 @ 2:30pm

SEALED BID RECEIVED
CLERK OF THE BOARD OF SUPERVISORS

RECEIVED RIVERSIDE COUNTY
CLERK / BOARD OF SUPERVISORS
2010 OCT 25 PM 2:28

CONTRACTOR'S PROPOSAL
Rancho Jurupa Regional Sports Complex

TO THE GOVERNING BOARD OF THE REDEVELOPMENT AGENCY FOR THE COUNTY OF RIVERSIDE:

Date: October 25, 2010

Bidder: Jaynes Corporation of CA

The undersigned, having carefully examined the proposed site and the Plans and Specifications, the Notice Inviting Bids, the Instructions to Bidders, the Agreement Form, the Bond Forms, the General Conditions for the Construction of the Rancho Jurupa Regional Sports Complex, hereby proposes and agrees to furnish all tools, equipment, services, apparatus, facilities, transportation, labor and materials necessary to complete the work in strict conformity with the Plans and Specifications, including all work specified in Addenda numbered and dated:

Addendum No. <u>001</u>	Date <u>10/07/10</u>
Addendum No. <u>002</u>	Date <u>10/13/10</u>
Addendum No. <u>003</u>	Date <u>10/15/10</u>
Addendum No. <u>004</u>	Date <u>10/20/10</u>
Addendum No. <u>005</u>	Date <u>10/22/10</u>
Addendum No. _____	Date _____
Addendum No. _____	Date _____

BASE BID

Clear and Grub/Demolition:	\$ <u>43,000</u>
Grading and Drainage:	\$ <u>1,600,000</u>
Water and Sewer:	\$ <u>25,000</u>
Electrical:	\$ <u>1,090,000</u>
Site Construction:	\$ <u>6,650,000</u>
Irrigation:	\$ <u>650,000</u>
Planting:	\$ <u>508,000</u>

For the total Base Bid ten million five hundred sixty six thousand dollars
(in words)

(\$ 10,566,000)

including all applicable taxes, permits, licenses, AND **Course of Construction Insurance**,

ALTERNATE BID ITEMS

(Add or Deduct state which)

1. Alternate Bid Synthetic Turf "FieldTurf Prestige XM50"
(refer to specifications section 02890.05 A)

\$ 200,000 deduct

2. Alternate Bid Synthetic Turf "Mondo Green Ecofill MF4563"
(refer to specifications section 02890.05 B)

\$ 700,000 add

3. Alternate Bid Synthetic Turf "Sprinturf Ultrablade DF"
(refer to specifications section 02890.05 C)

\$ 290,000 deduct

4. Alternate Bid Football Field
Item includes football field striping, combination football/soccer goals and steel posts and netting. Original soccer goals shall be included in the base bid.

\$ 50,000 add

5. Alternate Bid provide Hanson Associates Fabric Shade Structures, 13120
(as listed by contractor) Section

\$ 200,000 deduct

6. Alternate Bid _____
(as listed by contractor)

\$ _____

7. Alternate Bid _____
(as listed by contractor)

\$ _____

8. Alternate Bid _____
(as listed by contractor)

\$ _____

9. Alternate Bid _____
(as listed by contractor)

\$ _____

10. Alternate Bid _____
(as listed by contractor)

\$ _____

And, Cost of Contractor's Course of Construction Insurance seventeen thousand dollars (\$ 17,000) and deductible \$ 25,000.

Bids must be submitted on all items (except Alternate Bid items 5-10 if not needed by contractor). Failure to bid on all items may result in the bid being rejected as non-responsive. The basis for award will be the qualified bidder with the lowest total of the Base Bid WITH COURSE OF CONSTRUCTION INSURANCE. Alternates may be awarded in any order after determination of the lowest responsible and responsive bidder.

DESIGNATION OF SUBCONTRACTORS

In compliance with Section 4104 of the Public Contract Code the undersigned submits the following complete list of each Subcontractor who will perform work or labor or render service in or about the construction/installation in an amount in excess of 1/100th 1% of said total bid.

<u>PORTION OF THE WORK</u>	<u>SUBCONTRACTOR</u>	<u>ADDRESS</u>
Site Clearing/Earthwork	Dependable	Hemet
Dewatering	viking	West Sacramento Sacramento
Site Utilities	(Universal)	Murrieta
Asphalt Paving	Pave West	La Habra
Precast Concrete Pavers	Land Engineering	Riverside
Fencing	Fence Corp.	Oceanside
Synthetic Turf	Field Turf	Montreal, Canada
Synthetic Turf Drainage	Park West Sports	Rancho Santa Margarita
Masonry	JB Masonry	El Cajon

DESIGNATION OF SUBCONTRACTORS (continued)

In compliance with Section 4104 of the Public Contract Code the undersigned submits the following complete list of each Subcontractor who will perform work or labor or render service in or about the construction/installation in an amount in excess of 1/100th 1% of said total bid.

<u>PORTION OF THE WORK</u>	<u>SUBCONTRACTOR</u>	<u>ADDRESS</u>
Metal Fabrications PC		
Pre-Fab Buildings	# public Restroom Company	Reno Nevada
Icon Shade Structures Installation	TD Grogan	Rancho Cucamonga
Fabric Shade Structures	Shade Structures	Costa Mesa
Electrical	Ace	San Diego
Alt. #2 Synthetic Turf	Mondo	Santa Rosa
Alt. #3 Synthetic Turf	Sprint Turf	King of Prussia, PA.
Site Concrete	Southwest Construction	Fallbrook
Soccer Field Equipment	Tomark	Carona
Landscaping - Irrigation	Advanced Landscape 2000	Woodland Hills

AWARD OF CONTRACT

The undersigned fully understands that a Contract is formed upon the acceptance of this Proposal by the Owner and the undersigned further agrees that upon request he will promptly execute and deliver to Owner a written memorial of the Contract together with the required Payment and Performance Bonds and proof of insurance.

BID GUARANTEE

The enclosed certified or cashier's check or bidder's bond on approved form, made payable to the Owner in the amount of ten percent of the total bid submitted herewith, is hereby given as a guarantee that the bidder will execute and deliver the above mentioned written memorial and required bonds and insurance if awarded the contract, and in the event that the undersigned fails or refuses to execute and deliver said documents, such check or bond is to be charged with the costs of the damages experienced by the Owner as a result of such failure or refusal, including but not limited to publication costs, the difference in money between the amount of the bid of the said principal and the amount for which obligee may legally contract with another party to perform the said work if such amount be in excess of the former, building lease or rental costs, transportation costs and additional salary costs that result from the delay due to the principal's default on the awarded contract. In no event, however, shall the Surety's liability exceed the penal sum hereof.

Name of Bidder: Jaynes Corporation of CA

Type of Organization: Corporation

Signed By: 

Title of Signer: Richard Cohen
Executive Vice-President

Affix Seal
If
Corporation

Address of Bidder: 111 Elm Street, Fourth Floor
San Diego, CA 92101

Telephone No.: (619) 233-4080

Contractor's License No.: 787005

Classification: A, B, C-8 Expiration Date: 11/30/10

LICENSURE STATEMENTS ARE MADE UNDER PENALTY OF PERJURY

If bidder is a corporation, and signer is not President or Secretary, attach a certified copy of By-Laws or resolution authorizing execution. If bidder is a corporation, affix corporate seal. If signer is an agent, attach Power of Attorney. If bidder is not an individual, list names of other persons authorized to bind the organization.

JAYNES CORPORATION OF CALIFORNIA
SECRETARY'S CERTIFICATE

I, Wayne Davenport, Secretary of Jaynes Corporation (formerly known as Kvaas Constructors, Inc.), a California corporation (the "Corporation"), hereby certify as follows:

1. I am the duly elected, qualified and acting Secretary of the Corporation.
2. The following resolution was duly adopted by the Board of Directors of the Corporation at a meeting held on June 17, 2008. Such resolution has not been amended, modified or rescinded, and remains in full force and effect as of the date hereof:

WHEREAS: The Corporation is currently conducting and is expected to regularly conduct business with various agencies and owners (collectively "Owners") within the state of California, which business entails executing and delivering various documents and agreements with Owners, consistent with the Corporation's objectives, and

WHEREAS: It is deemed to be in the best interests of the Corporation to authorize Richard Cohen, the Executive Vice President of the Corporation, to execute and deliver any and all documents and agreements with Owners that he deems necessary or advisable,

IT IS HEREBY RESOLVED: Richard Cohen, the Executive Vice President, is authorized and directed to execute and deliver any and all documents and agreements with Owners on behalf of the Corporation that either of them deems necessary or advisable, and to take such further action as is necessary to carry out the purpose and intent of this resolution as either one, in his discretion, deems advisable.

IN WITNESS WHEREOF, I have executed this Certificate as of September 11, 2008.

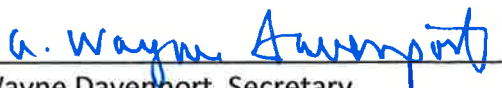

Wayne Davenport, Secretary

**NONCOLLUSION AFFIDAVIT TO BE EXECUTED BY BIDDER AND
SUBMITTED WITH BID**

State of California) ss.
County of Riverside)

Richard Cohen, being first duly sworn, deposes and says:

That he or she is Executive Vice-President of Jaynes Corporation of CA the party making the foregoing bid; that the bid is not made in the interest of, or on behalf of, any undisclosed person, partnership, company, association, organization, or corporation; that the bid is genuine and not collusive or sham; that the bidder has not directly or indirectly induced or solicited any other bidder to put in a false or sham bid, and has not directly or indirectly colluded, conspired, connived, or agreed with any bidder or anyone else to put in a sham bid, or that anyone shall refrain from bidding; that the bidder has not in any manner, directly or indirectly, sought by agreement, communication, or conference with anyone to fix the bid price of the bidder or any other bidder, or to fix any overhead, profit, or cost element of the bid price, or of that of any other bidder, or to secure any advantage against the public body awarding the contract of anyone interested in the proposed contract; that all statements contained in the bid are true; and, further, that the bidder has not, directly or indirectly, submitted his or her bid price or any breakdown thereof, or the contents thereof, or divulged information or data relative thereto, or paid, and will not pay, any fee to any corporation, partnership, company association, organization, bid depository, or to any member or agent thereof to effectuate a collusive or sham bid.

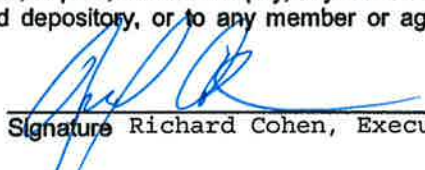
Signature Richard Cohen, Executive V.P.

Subscribed and sworn to before me this _____ day of _____, 2010

(See Attached)
Signature of officer administering oath

CALIFORNIA JURAT WITH AFFIANT STATEMENT

- See Attached Document (Notary to cross out lines 1-6 below)
 See Statement Below (Lines 1-5 to be completed only by document signer[s], *not* Notary)

Signature of Document Signer No. 1

Signature of Document Signer No. 2 (if any)

State of California

County of San Diego

Subscribed and sworn to (or affirmed) before me on this

25th day of October, 2010, by
Date Month Year

(1) Richard Cohen
Name of Signer

proved to me on the basis of satisfactory evidence to be the person who appeared before me (.)

(and

(2) _____
Name of Signer

proved to me on the basis of satisfactory evidence to be the person who appeared before me.)

Signature Valerie T. Doering
Signature of Notary Public



Place Notary Seal Above

OPTIONAL

Though the information below is not required by law, it may prove valuable to persons relying on the document and could prevent fraudulent removal and reattachment of this form to another document.

Further Description of Any Attached Document

Title or Type of Document: _____

Document Date: _____ Number of Pages: _____

Signer(s) Other Than Named Above: _____

RIGHT THUMBPRINT
OF SIGNER #1
Top of thumb here

RIGHT THUMBPRINT
OF SIGNER #2
Top of thumb here

Bid Bond

KNOWN TO ALL MEN BY THESE PRESENTS, that we, the undersigned JAYNES CORPORATION OF CALIFORNIA, as Principal; and WESTERN SURETY COMPANY, as Surety, are hereby held and firmly bound unto the Redevelopment Agency for the County of Riverside, hereinafter called the "Owner", in the sum of TEN PERCENT (10%) OF THE AMOUNT BID--- Dollars (\$ _____) for the payment of such sum, well and truly to be made, do hereby jointly and severally bind ourselves, our heirs, executors, administrators, successors and assigns.

WHEREAS, the said Principal is herewith submitting its Proposal for the RANCHO JURUPA REGIONAL SPORTS COMPLEX

THE CONDITION OF THE ABOVE OBLIGATION IS SUCH, that if the aforesaid Principal shall be awarded the Contract upon said Proposal and shall, within the required number of days after the notice of such award, execute a written memorial of the awarded Contract and submit the required Labor and Material Payment and faithful Performance Bond and proof of insurance, then this obligation shall be null and void; and in the event that the Principal fails and/or refuses to execute and deliver said documents this Bond will be charged with the costs of the damages experienced by the Owner as a result of such refusal, including but not limited to, publication cost, the difference in money between the amount of the bid of the said Principal and the amount for which the obligee may legally contract with another party to perform the said work if such amount be in excess of the former; building lease or rental costs, transportation cost, and additional salary costs that result from the delay due to the Principal's default on the awarded Contract. In no event however, shall the Surety's liability exceed the penal sum hereof.

The Surety, for value received, hereby stipulates and agrees that the obligations of said Surety and its bond shall be in no way impaired or affected by any extension of the time within which the Owner may accept such bid; and said Surety does hereby waive notice of any such extension.

IN WITNESS WHEREOF, the above bounded parties have executed this instrument under their separate seals this 25TH day of OCTOBER, 2010, the name and corporate seal of each corporate party being hereto affixed and those present duly signed by its undersigned representative, pursuant to authority of its governing body.

JAYNES CORPORATION OF CALIFORNIA
(Firm Name - Principal)

111 Elm Street, 4th Floor, San Diego, CA 92101
(Business Address)

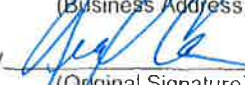
By 
(Original Signature) Richard Cohen,
Executive Vice-President
(Title)

Affix Seal
If
Corporation

WESTERN SURETY COMPANY
(Corporation Name - Surety)

320 Osuna NE, Suite G-1, Albuquerque, NM 87107
(Business Address)

By 
(Original Signature) CARL S. CONLEE, III, ATTORNEY-IN-FACT

Affix
Corporate
Seal

CALIFORNIA ALL-PURPOSE ACKNOWLEDGMENT

New Mexico
State of ~~California~~ }
County of Bernalillo

On October 25, 2010 before me, Muriel Bray, Notary Public
Date Here Insert Name and Title of the Officer

personally appeared Carl S. Conlee, III
Name(s) of Signer(s)

who proved to me on the basis of satisfactory evidence to be the person(s) whose name(s) is/are subscribed to the within instrument and acknowledged to me that he/she/they executed the same in his/her/their authorized capacity(ies), and that by his/her/their signature(s) on the instrument the person(s), or the entity upon behalf of which the person(s) acted, executed the instrument.



OFFICIAL SEAL
Muriel Bray
NOTARY PUBLIC-STATE OF NEW MEXICO

My commission expires: 12/22/12

I certify under PENALTY OF PERJURY under the laws of the State of California that the foregoing paragraph is true and correct.

WITNESS my hand and official seal.

Signature Muriel Bray
Signature of Notary Public
My Commission Expires: December 22, 2012

Place Notary Seal Above

OPTIONAL

Though the information below is not required by law, it may prove valuable to persons relying on the document and could prevent fraudulent removal and reattachment of this form to another document.

Description of Attached Document

Title or Type of Document: _____

Document Date: _____ Number of Pages: _____

Signer(s) Other Than Named Above: _____

Capacity(ies) Claimed by Signer(s)

Signer's Name: _____

- Individual
- Corporate Officer — Title(s): _____
- Partner — Limited General
- Attorney in Fact
- Trustee
- Guardian or Conservator
- Other: _____



Signer Is Representing: _____

Signer's Name: _____

- Individual
- Corporate Officer — Title(s): _____
- Partner — Limited General
- Attorney in Fact
- Trustee
- Guardian or Conservator
- Other: _____



Signer Is Representing: _____

Western Surety Company

POWER OF ATTORNEY APPOINTING INDIVIDUAL ATTORNEY-IN-FACT

Know All Men By These Presents, That WESTERN SURETY COMPANY, a South Dakota corporation, is a duly organized and existing corporation having its principal office in the City of Sioux Falls, and State of South Dakota, and that it does by virtue of the signature and seal herein affixed hereby make, constitute and appoint

Robert L Brooks, Bart H Kinney III, Michael L Chrestman, Carl S Conlee III, Dean E Vigil, Sarah J Hamilton, David D Gebhardt, Sally L Nelson, Individually

of Albuquerque, NM, its true and lawful Attorney(s)-in-Fact with full power and authority hereby conferred to sign, seal and execute for and on its behalf bonds, undertakings and other obligatory instruments of similar nature

- In Unlimited Amounts -

and to bind it thereby as fully and to the same extent as if such instruments were signed by a duly authorized officer of the corporation and all the acts of said Attorney, pursuant to the authority hereby given, are hereby ratified and confirmed.

This Power of Attorney is made and executed pursuant to and by authority of the By-Law printed on the reverse hereof, duly adopted, as indicated, by the shareholders of the corporation.

In Witness Whereof, WESTERN SURETY COMPANY has caused these presents to be signed by its Senior Vice President and its corporate seal to be hereto affixed on this 24th day of October, 2006.



WESTERN SURETY COMPANY

Paul T. Bruflat, Senior Vice President

State of South Dakota }
County of Minnehaha } ss

On this 24th day of October, 2006, before me personally came Paul T. Bruflat, to me known, who, being by me duly sworn, did depose and say: that he resides in the City of Sioux Falls, State of South Dakota; that he is the Senior Vice President of WESTERN SURETY COMPANY described in and which executed the above instrument; that he knows the seal of said corporation; that the seal affixed to the said instrument is such corporate seal; that it was so affixed pursuant to authority given by the Board of Directors of said corporation and that he signed his name thereto pursuant to like authority, and acknowledges same to be the act and deed of said corporation.

My commission expires

November 30, 2012

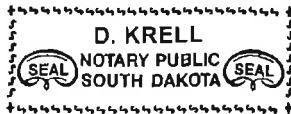

D. Krell, Notary Public

CERTIFICATE

I, L. Nelson, Assistant Secretary of WESTERN SURETY COMPANY do hereby certify that the Power of Attorney hereinabove set forth is still in force, and further certify that the By-Law of the corporation printed on the reverse hereof is still in force. In testimony whereof I have hereunto subscribed my name and affixed the seal of the said corporation this 25TH day of OCTOBER, 2010.



WESTERN SURETY COMPANY

L. Nelson, Assistant Secretary



ECONOMIC DEVELOPMENT AGENCY – COUNTY OF RIVERSIDE

ADDENDUM NO. 001

**TO BIDDING DOCUMENTS, CONTRACT, BASIC SPECIFICATIONS, AND SPECIAL REQUIREMENTS
FOR
RANCHO JURUPA REGIONAL SPORTS COMPLEX**

Bidders are advised that the Contract Documents for the above referenced contract are hereby amended in the following manner and in the following manner only:

A. GENERAL ITEMS

1. All provisions of this Addendum No. 001 are hereby incorporated into the contract documents, and bidders shall account for all provisions pursuant to this Addendum No. 001 in submitting their bid proposals. Each bidder shall include a dated and signed copy of this Addendum No. 001 with his sealed bid proposal.
2. Mandatory Job Walk will take place on Wednesday, October 13, 2010 at 10:00 am. The location of the job walk will be at 4800 Crestmore Road, Riverside CA 92509-6839. Follow the directional signs into the Park. The meeting location will be at the Pecan Shade Shelter.
3. Plans and specifications are available at OCB Reprographics of Riverside. Please contact them for cost of plans and specifications.

B. PLAN & SPECIFICATION ITEMS

1. Replace the following specification sections with the specifications attached.
02441, 02461, 02740, 02763, 02783, 02890, 09860, 16000
2. Add the following specification sections attached.
13000, 13120
3. Turf shall be SOD only. Remove reference to hydroseed turf on planting plans.
4. Construction Plan item 24b on sheet CP-2 shall be changed to item 24a.

www.rivcoeda.org

Administration
A-1000
Business Intelligence
Cultural Services
Community Services
Custodial

Housing
Housing Authority
Information Technology
Maintenance
Recycling

Economic Development
Edward Deon Museum
Environmental Planning
Fair & National Days Festival
Foreign Trade
Grants Administration

Parking
Project Management
Purchasing Group
Real Property
ReDevelopment Agency
Workforce Development

5. Contractor shall note the requirement of providing for turnover to the County a synthetic turf sweeper and groomer as part of the base bid cost as noted on page 9 of specification section 02890.
6. Contractor shall note that the drainline shown on sheets C5 and C9 shall NOT be installed under the concrete paving as shown. Drainline shall be installed as shown on sheet TD-1.
7. The County will provide all site survey services. Section 8.9.1 under "LAYOUT OF WORK" shall be modified accordingly.
8. The attached "Contractor's Proposal" shall be used in place of the one in the original bid specifications.

DATED: October 7, 2010

By: _____
Jason Plotkin, Project Manager

10/12/10
Date Received by Bidder

By: 
Bidder's Signature

Richard Cohen, Executive V.P.
Typed or Printed Name



ECONOMIC DEVELOPMENT AGENCY – COUNTY OF RIVERSIDE

ADDENDUM NO. 002

**TO BIDDING DOCUMENTS, CONTRACT, BASIC SPECIFICATIONS, AND SPECIAL REQUIREMENTS
FOR
RANCHO JURUPA REGIONAL SPORTS COMPLEX**

Bidders are advised that the Contract Documents for the above referenced contract are hereby amended in the following manner and in the following manner only:

A. GENERAL

- 1. All provisions of this Addendum No. 002 are hereby incorporated into the contract documents, and bidders shall account for all provisions pursuant to this Addendum No. 002 in submitting their bid proposals. Each bidder shall include a dated and signed copy of this Addendum No. 002 with his sealed bid proposal.**
- 2. The following Addendum No. 002 contains the job walk sign-in sheets, agenda, and answers to questions asked at the job walk.**

DATED: October 13, 2010

By: _____
Jason Plotkin, Project Manager

10/14/10
Date Received by Bidder

By: 

Bidder's Signature

Richard Cohen, Executive V.P.
Typed or Printed Name

www.rlvceda.org

Administration
Aviation
Business Intelligence
Cultural Services
Community Services
Customer

Housing
Housing Authority
Information Technology
Maintenance
Marketing

Economic Development
Edward Dean Museum
Environmental Planning
Fair & Historic Date Festival
Foreign Trade
Graffiti Abatement

Planning
Project Management
Purchasing Group
Real Property
Redevelopment Agency
Workforce Development



ECONOMIC DEVELOPMENT AGENCY – COUNTY OF RIVERSIDE

ADDENDUM NO. 003

**TO BIDDING DOCUMENTS, CONTRACT, BASIC SPECIFICATIONS, AND SPECIAL REQUIREMENTS
FOR
RANCHO JURUPA REGIONAL SPORTS COMPLEX**

Bidders are advised that the Contract Documents for the above referenced contract are hereby amended in the following manner and in the following manner only:

A. GENERAL ITEMS

1. All provisions of this Addendum No. 003 are hereby incorporated into the contract documents, and bidders shall account for all provisions pursuant to this Addendum No. 003 in submitting their bid proposals. Each bidder shall include a dated and signed copy of this Addendum No. 003 with his sealed bid proposal.

B. PLAN & SPECIFICATION ITEMS

1. Add football field striping, combination football/soccer goals and steel posts and netting to the southeast synthetic turf field (Field 2). Refer to attached sheets:
"RJRSC - Revised Sheet CP-2 (addendum #3).pdf"
"RJRSC - Revised Sheet LP-2 (addendum #3).pdf"
"RJRSC - Revised Sheet CD-4 (addendum #3).pdf"
2. Revise soccer goals on Fields 5 and 6 per attached sheet:
"RJRSC - Revised Sheet CP-2 (addendum #3).pdf".
3. Note locations of playground gravel sumps added to detail 'A' on attached sheet:
"RJRSC - Revised Sheet CD-2 (addendum #3).pdf".
4. Change Ackerstone paver color to "Charcoal Brown Buff" as shown on attached sheet:
"RJRSC - Revised Sheet CP-2 (addendum #3).pdf"

www.rlvcoeda.org

Administration
Aviation
Business Intelligence
Cultural Services
Community Services
Custodial

Housing
Housing Authority
Information Technology
Maintenance
Marketing

Economic Development
Edward-Dean Museum
Environmental Planning
Fair & National Game Festival
Foreign Trade
Graffiti Abatement

Parking
Project Management
Purchasing Group
Real Property
Recreation Agency
Workforce Development

5. Replace specification Section 02890 – Synthetic Turf with the attached file:
"02890 - SYNTHETIC TURF SYSTEM (rev for Addendum #3).pdf"

Note change to 02890.06 Item 2:

2. *In the event that the Prime Contractor does not meet these requirements, a sub-contractor may be listed that does meet the requirements specified in item 1 above. The Prime Contractor shall provide evidence of experience by the listed sub-contractor in preparing drainage base systems for synthetic turf and the sub-contractor must have installed a minimum of 10 sub-grade drainage base systems for synthetic turf playing fields in the past 3 years in California.*

6. Replace the Contractor's Proposal with the attached file:
"RJRSC Contractor's Proposal - Addendum #3 (10-15-10).pdf"

DATED: October 15, 2010

By: _____
Jason Plotkin, Project Manager

10/15/10
Date Received by Bidder

By:  _____
Bidder's Signature

Richard Cohen, Executive V.P.
Typed or Printed Name



ECONOMIC DEVELOPMENT AGENCY – COUNTY OF RIVERSIDE

ADDENDUM NO. 004

**TO BIDDING DOCUMENTS, CONTRACT, BASIC SPECIFICATIONS, AND SPECIAL REQUIREMENTS
FOR
RANCHO JURUPA REGIONAL SPORTS COMPLEX**

Bidders are advised that the Contract Documents for the above referenced contract are hereby amended in the following manner and in the following manner only:

A. GENERAL ITEMS

1. All provisions of this Addendum No. 004 are hereby incorporated into the contract documents, and bidders shall account for all provisions pursuant to this Addendum No. 004 in submitting their bid proposals. Each bidder shall include a dated and signed copy of this Addendum No. 004 with his sealed bid proposal.
2. The cutoff for RFI's has changed to **Thursday, October 21, 2010 at 2:30pm**

B. PLAN & SPECIFICATION ITEMS

1. Change the play equipment model number in the construction legend items "D" and "E" on detail "A" sheet CD-2, to 31360-1-2.
2. Specification Section 13000.F.1. shall be changed to "The OWNER is responsible for the site survey and staking the building location,"
3. The quantity of picnic tables on CP-1 and CP-2, item 16 shall be changed to **52**.
4. The retaining walls located along the north property line shall be constructed per detail H, sheet C2 as indicated on sheets C3 and C4. The retaining walls located on the north and west sides of the soccer field adjacent to the concrete paving shall be constructed per details A and D, sheet CD-3 as indicated on sheet CP-2.
5. Detail A and D on sheet CD-3 show a typical mow curb against wall, where turf occurs. It then references detail F, on CD-1 which is the monument sign, which is incorrect. A mow curb detail has been included as part of this addendum.

www.rivcoedd.org

Administration
Aviation
Business Intelligence
Cultural Services
Community Services
Customs

Housing
Housing Authority
Information Technology
Maintenance
Marketing

Economic Development
Edward-Dean Museum
Environmental Planning
Fair & National Date Festival
Foreign Trade
Graffiti Abatement

Parking
Project Management
Purchasing Group
Real Property
Redevelopment Agency
Workforce Development

6. Specification Section 02890.08 Field Conditions **Part A** shall be removed from the specifications.
7. The contractor shall be required to prepare the Storm Water Pollution Prevention Plan (SWPPP) for the project. The SWPPP shall meet all requirements of the **2009-0009-DWQ Construction general permit** which can be found at:
http://www.swrcb.ca.gov/water_issues/programs/stormwater/constpermits.shtml
8. The connection to the existing flood control down drain shall be made utilizing a concrete collar in accordance with APWA STD 380-4.
9. The electrical plan sheets (E-1, E-2, E-3, E-4, E-5, E-6, E-7, E-8, E-9, E-10) dated 5/10/10 shall be replaced with the attached sheets dated 5/27/10. Information missing from the original sheets has been added.
10. All work within 5' of the synthetic turf system, both above and below ground, must be performed by a qualified contractor according to the project specifications. Pre-qualifications shall be submitted for the synthetic field installers **AND** sub-drain and crushed rock preparation installers. The pre-qualifications can be submitted **within 24 hours after the bid opening by the three apparent low bidders.**
11. The 15" drain line indicated on sheet C9 should be revised to the 18" perforated drain as indicated within the specs. The 48" perforated drain line adjacent to the parking lot is the infiltration trench drain for water quality purposes and is considered to be part of the perimeter drain system for the synthetic turf fields. In addition, all drain inlets and laterals that connect to the perimeter drain system are considered part of the synthetic turf sub-drainage system and must be installed by a qualified sub-drainage subcontractor with 10 fields in 3 years experience per the project specifications. The connections must be made to 5' outside of the trench/synthetic turf area where a qualified underground utility contractor may pick up the connection and install the rest of the upstream system.
12. The sidewalk that is referred to in detail C sheet C-3 is the public sidewalk within the County right-of-way that is indicated on the SP sheets. This sidewalk per County standard is a 4" thick sidewalk. Interior sidewalks (outside of the R/W) shall be 6" thick per the CP sheets.
13. Sheets C7 and C11 were labeled incorrectly; the scale of these sheets is 1"=30'.
14. Wire note #1 on sheet IP-1 specifies "All valve control / common wires shall be installed in a schedule 40 gray PVC conduit per detail "B" sheet ID-1". The detail reference should be **detail "I" sheet ID-1**. All common, pilot and spare wires shall be installed inside schedule 40 PVC grey conduit in a **continuous** route from controllers to all the remote control valve locations.
15. The pipe for all drinking fountain lines shall be schedule 40 PVC.
16. All 6" irrigation pipe shall be Class 200 PVC Ring-Tite.

17. The exterior of the trash enclosure walls shall have a stone veneer wainscot to match the electrical enclosure on detail "E" sheet CD-2.
18. Refer to Stone Veneer Column detail included in Addendum #4 for detail on stone veneer columns at the shade structure posts.

DATED: October 20, 2010

10/20/10
Date Received by Bidder

By: _____
Jason Plotkin, Project Manager

By: 
Bidder's Signature

Richard Cohen, Executive V.P.
Typed or Printed Name



ECONOMIC DEVELOPMENT AGENCY – COUNTY OF RIVERSIDE

ADDENDUM NO. 005

**TO BIDDING DOCUMENTS, CONTRACT, BASIC SPECIFICATIONS, AND SPECIAL REQUIREMENTS
FOR
RANCHO JURUPA REGIONAL SPORTS COMPLEX**

Bidders are advised that the Contract Documents for the above referenced contract are hereby amended in the following manner and in the following manner only:

A. GENERAL ITEMS

1. All provisions of this Addendum No. 005 are hereby incorporated into the contract documents, and bidders shall account for all provisions pursuant to this Addendum No. 005 in submitting their bid proposals. Each bidder shall include a dated and signed copy of this Addendum No. 005 with his sealed bid proposal.

B. PLAN & SPECIFICATION ITEMS

1. All concrete paving shall be 3,250 psi per plans. The reference to 4,000 psi concrete in the Geotechnical Report shall be revised to 3,250 psi.
2. Detail 'C', Sheet CD-3 shall be modified to have the gravel base and geotextile fabric extend 18" beyond the edge of the concrete pavers.
3. Construct a 6" wide by 16" deep concrete curb to separate the asphalt paving and permeable pavers. Install continuous #4 rebar 3" below top of curb and 1" deep score joints at 10' O.C. The top of curb is to be flush with the adjacent pavers and asphalt paving.
4. The existing stump and tree along Loring Ranch are to be removed.
5. The reference to hydroseed turf on sheets PP-1 and PP-2 shall be removed. The base bid shall be sod turf as specified on the plans.
6. The alternate bid item for the football striping shall also include increasing the length of the synthetic turf blades to a minimum of 2.5".

DATED: October 22, 2010

By: _____
Jason Plotkin, Project Manager

10/22/10
Date Received by Bidder

By:  _____
Bidder's Signature

Richard Cohen, Executive V.P.
Typed or Printed Name



JAYNES CORPORATION
GENERAL CONTRACTORS
111 Elm Street, Fourth Floor
San Diego, CA 92101-2649

SEALED BID DOCUMENTS

Rancho Jurupa Regional Sports Complex
Redevelopment Agency of the County of Riverside
Bid Date: October 25, 2010 @ 2:30pm

County of Riverside, Clerk of the Board
County Administrative Center, 1st Floor
4080 Lemon Street
Riverside, CA 92501

SEALED BID RECEIVED
CLERK OF THE BOARD OF SUPERVISORS

RECEIVED RIVERSIDE COUNTY
CLERK / BOARD OF SUPERVISORS
2010 OCT 25 PM 2:25