

**Bid Bond**

KNOWN TO ALL MEN BY THESE PRESENTS, that we, the undersigned NBI General Contractors, Inc., as Principal; and Safeco Insurance Company of America, as Surety, are hereby held and firmly bound unto the County of Riverside, hereinafter called the "Owner", in the sum of Ten Percent of Amount Bid Dollars (\$10% of Bid) for the payment of such sum, well and truly to be made, do hereby jointly and severally bind ourselves, our heirs, executors, administrators, successors and assigns.

WHEREAS, the said Principal is herewith submitting its Proposal for the US Depart. Of Energy's Solar Projects CAC Parking Structure Solar System & Lighting Upgrade

THE CONDITION OF THE ABOVE OBLIGATION IS SUCH, that if the aforesaid Principal shall be awarded the Contract upon said Proposal and shall, within the required number of days after the notice of such award, execute a written memorial of the awarded Contract and submit the required Labor and Material Payment and faithful Performance Bond and proof of insurance, then this obligation shall be null and void; and in the event that the Principal fails and/or refuses to execute and deliver said documents this Bond will be charged with the costs of the damages experienced by the Owner as a result of such refusal, including but not limited to, publication cost, the difference in money between the amount of the bid of the said Principal and the amount for which the obligee may legally contract with another party to perform the said work if such amount be in excess of the former; building lease or rental costs, transportation cost, and additional salary costs that result from the delay due to the Principal's default on the awarded Contract. In no event however, shall the Surety's liability exceed the penal sum hereof.

The Surety, for value received, hereby stipulates and agrees that the obligations of said Surety and its bond shall be in no way impaired or affected by any extension of the time within which the Owner may accept such bid; and said Surety does hereby waive notice of any such extension.

IN WITNESS WHEREOF, the above bounded parties have executed this instrument under their separate seals this 20th day of December, 2010, the name and corporate seal of each corporate party being hereto affixed and those present duly signed by its undersigned representative, pursuant to authority of its governing body.

NBI General Contractors, Inc.  
(Firm Name - Principal)

1770 Howard Place, Redlands, CA 92373  
(Business Address)

By [Signature]  
(Original Signature)

JAMES P. O'HARA, PRESIDENT  
(Title)

Safeco Insurance Company of America  
(Corporation Name - Surety)

330 N. Brand Blvd., Suite 500, Glendale, CA 91203  
(Business Address)

By [Signature]  
(Original Signature) Arturo Ayala,  
Attorney-In-Fact

Affix Seal  
If  
Corporation

Affix  
Corporate  
Seal

# CALIFORNIA ALL-PURPOSE ACKNOWLEDGMENT

STATE OF CALIFORNIA

County of Riverside }

On 12/20/10 before me, Susan Pugh, Notary Public,  
Date Here Insert Name and Title of the Officer

personally appeared Arturo Ayala  
Name(s) of Signer(s)

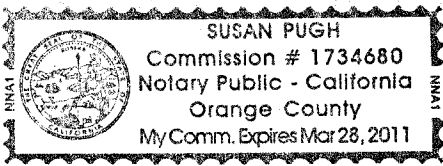

who proved to me on the basis of satisfactory evidence to be the person(s) whose name(s) is/~~are~~ subscribed to the within instrument and acknowledged to me that he/~~she~~/they executed the same in his/~~her~~/their authorized capacity(ies), and that by his/~~her~~/their signature(s) on the instrument the person(s), or the entity upon behalf of which the person(s) acted, executed the instrument.

I certify under PENALTY OF PERJURY under the laws of the State of California that the foregoing paragraph is true and correct.

Witness my hand and official seal.

Signature Susan Pugh  
Signature of Notary Public Susan Pugh

Place Notary Seal Above

## OPTIONAL

*Though the information below is not required by law, it may prove valuable to persons relying on the document and could prevent fraudulent removal and reattachment of this form to another document.*

### Description of Attached Document

Title or Type of Document: Bid Bond

Document Date: 12/20/10 Number of Pages: One

Signer(s) Other Than Named Above: None

### Capacity(ies) Claimed by Signer(s)

Signer's Name: Arturo Ayala

- Individual
- Corporate Officer — Title(s): \_\_\_\_\_
- Partner —  Limited  General
- Attorney in Fact
- Trustee
- Guardian or Conservator
- Other: \_\_\_\_\_

**RIGHT THUMBPRINT OF SIGNER**

Top of thumb here

Signer Is Representing:  
\_\_\_\_\_  
\_\_\_\_\_  
\_\_\_\_\_

Signer's Name: \_\_\_\_\_

- Individual
- Corporate Officer — Title(s): \_\_\_\_\_
- Partner —  Limited  General
- Attorney in Fact
- Trustee
- Guardian or Conservator
- Other: \_\_\_\_\_

**RIGHT THUMBPRINT OF SIGNER**

Top of thumb here

Signer Is Representing:  
\_\_\_\_\_  
\_\_\_\_\_  
\_\_\_\_\_

This Power of Attorney limits the acts of those named herein, and they have no authority to bind the Company except in the manner and to the extent herein stated.

**SAFECO INSURANCE COMPANY OF AMERICA  
SEATTLE, WASHINGTON  
POWER OF ATTORNEY**

**KNOW ALL PERSONS BY THESE PRESENTS:** That Safeco Insurance Company of America (the "Company"), a Washington stock insurance company, pursuant to and by authority of the By-law and Authorization hereinafter set forth, does hereby name, constitute and appoint **DANIEL HUCKABAY, ARTURO AYALA, DWIGHT REILLY, ALLISON RITTO, ALL OF THE CITY OF ORANGE, STATE OF CALIFORNIA** .....

.....  
.....  
each individually if there be more than one named, its true and lawful attorney-in-fact to make, execute, seal, acknowledge and deliver, for and on its behalf as surety and as its act and deed, any and all undertakings, bonds, recognizances and other surety obligations in the penal sum not exceeding **SEVENTY FIVE MILLION AND 00\*\*\*\*\* DOLLARS (\$ 75,000,000.00\*\*\*\*\* )** each, and the execution of such undertakings, bonds, recognizances and other surety obligations, in pursuance of these presents, shall be as binding upon the Company as if they had been duly signed by the president and attested by the secretary of the Company in their own proper persons.

That this power is made and executed pursuant to and by authority of the following By-law and Authorization:

**ARTICLE IV - Execution of Contracts: Section 12. Surety Bonds and Undertakings.**

Any officer or other official of the Corporation authorized for that purpose in writing by the Chairman or the President, and subject to such limitations as the Chairman or the President may prescribe, shall appoint such attorneys-in-fact, as may be necessary to act in behalf of the Corporation to make, execute, seal, acknowledge and deliver as surety any and all undertakings, bonds, recognizances and other surety obligations. Such attorneys-in-fact, subject to the limitations set forth in their respective powers of attorney, shall have full power to bind the Corporation by their signature and executed, such instruments shall be as binding as if signed by the president and attested by the secretary.

By the following instrument the chairman or the president has authorized the officer or other official named therein to appoint attorneys-in-fact:

Pursuant to Article IV, Section 12 of the By-laws, Garnet W. Elliott, Assistant Secretary of Safeco Insurance Company of America, is authorized to appoint such attorneys-in-fact as may be necessary to act in behalf of the Corporation to make, execute, seal, acknowledge and deliver as surety any and all undertakings, bonds, recognizances and other surety obligations.

That the By-law and the Authorization set forth above are true copies thereof and are now in full force and effect.

IN WITNESS WHEREOF, this Power of Attorney has been subscribed by an authorized officer or official of the Company and the corporate seal of Safeco Insurance Company of America has been affixed thereto in Plymouth Meeting, Pennsylvania this 30th day of August, 2010.



**SAFECO INSURANCE COMPANY OF AMERICA**

By Garnet W. Elliott  
Garnet W. Elliott, Assistant Secretary

COMMONWEALTH OF PENNSYLVANIA ss  
COUNTY OF MONTGOMERY

On this 30th day of August, 2010, before me, a Notary Public, personally came Garnet W. Elliott, to me known, and acknowledged that he is an Assistant Secretary of Safeco Insurance Company of America; that he knows the seal of said corporation; and that he executed the above Power of Attorney and affixed the corporate seal of Safeco Insurance Company of America thereto with the authority and at the direction of said corporation.

IN TESTIMONY WHEREOF, I have hereunto subscribed my name and affixed my notarial seal at Plymouth Meeting, Pennsylvania, on the day and year first above written.

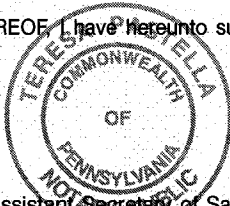

Notarial Seal  
Teresa Pastella, Notary Public  
Plymouth Twp., Montgomery County  
My Commission Expires Mar. 28, 2013  
Member, Pennsylvania Association of Notaries

By Teresa Pastella  
Teresa Pastella, Notary Public

**CERTIFICATE**

I, the undersigned, Assistant Secretary of Safeco Insurance Company of America, do hereby certify that the original power of attorney of which the foregoing is a full, true and correct copy, is in full force and effect on the date of this certificate; and I do further certify that the officer or official who executed the said power of attorney is an Assistant Secretary specially authorized by the chairman or the president to appoint attorneys-in-fact as provided in Article IV, Section 12 of the By-laws of Safeco Insurance Company of America.

This certificate and the above power of attorney may be signed by facsimile or mechanically reproduced signatures under and by authority of the following vote of the board of directors of Safeco Insurance Company of America at a meeting duly called and held on the 18th day of September, 2009.

VOTED that the facsimile or mechanically reproduced signature of any assistant secretary of the company, wherever appearing upon a certified copy of any power of attorney issued by the company in connection with surety bonds, shall be valid and binding upon the company with the same force and effect as though manually affixed.

IN TESTIMONY WHEREOF, I have hereunto subscribed my name and affixed the corporate seal of the said company, this 20th day of December, 2010.



By David M. Carey  
David M. Carey, Assistant Secretary

Not valid for mortgage, note, loan, letter of credit, bank deposit, currency rate, interest rate or equal value guarantees.

To confirm the validity of this Power of Attorney call 1-610-832-8240 between 9:00 am and 4:30 pm EST on any business day.

ID	Task Name	Duration	Start	Finish	February		
					1/16	1/23	2/6
1	Notice to Proceed	0 days	Tue 2/1/11	Tue 2/1/11			
2	Construction	54 days	Tue 2/1/11	Fri 4/15/11			
3	Construction Commencement	0 days	Tue 2/1/11	Tue 2/1/11			
4	Construct Concrete Footings	3 days	Tue 2/1/11	Thu 2/3/11			
5	Canopy Construction & Erection	14 days	Tue 2/1/11	Fri 2/18/11			
6	PV Panel Installation	40 days	Mon 2/21/11	Fri 4/15/11			
7	DC Distribution	20 days	Mon 2/21/11	Fri 3/18/11			
8	AC Distribution	20 days	Mon 2/21/11	Fri 3/18/11			
9	Monitoring Installation & Commissioning	14 days	Mon 3/21/11	Thu 4/7/11			
10	Commissioning & Close Out	16 days	Fri 4/8/11	Fri 4/29/11			
11	Building Final Inspection	1 day	Fri 4/8/11	Fri 4/8/11			
12	Utility Company Acceptance	14 days	Mon 4/11/11	Thu 4/28/11			
13	System Online	1 day	Fri 4/29/11	Fri 4/29/11			

Project: Bldg\_48 Estimated CPM.mpp  
Date: Wed 1/12/11

Task Progress Summary

Split Milestone Project Summary

# County of Riverside

## **REBID - CAC Parking Structure Solar System & Lighting Upgrade Addendums 1 & 2**

**To:** Erin Wilson  
NBI General Contractors, Inc. 3 Sets  
1770 Howard Place  
Redlands, California , 92373

**Phone:** 909-798-7300  
**Fax:** 909-798-7340  
**Email:** erin@nbigc.com

**From:** Mario Silva  
Mission Reprographics

**Phone:** 951-686-8828  
**Fax:** 951-686-7747  
**Email:** planwell@missionreprographics.com

Gentlemen:

We've attached Addendums 1 & 2 for the bid documents you've purchased. Add the following files to the end of your bid docs.

Please download Addendums 1 & 2 for your bid project:

**CAC Add 1.pdf**

**CAC Add 2.pdf**

**[Click here to view and order plans online, using PlanWell.](#)**

If you've only received the fax, please call 951-686-8828 and request Addendums 1 & 2 to be emailed to you.

**[Click here to acknowledge receipt of Addendums 1 & 2 and confirm your firm will submit a qualified bid.](#)**

**Note:** Please do not delete this email until after the bid due date...It will be used in the future to directly access additional plans, specs and addendum that may change and digitally view them free of charge.

Should there be any questions regarding your bid, feel free to contact Bruce Norris with the County of Riverside at 951-955-0353.

Thank you in advance for your willingness to consider this project.

Sincerely,

Mario Silva



Palm Desert | Santa Ana | San Diego

Date: December 6, 2010  
Project: CAC Parking Structure Solar Project  
Project No.: FM0672000027  
Addendum: **NUMBER ONE**

I. INSTRUCTIONS:

- A. This supplement to the bid package is issued prior to the receipt of proposals. All changes covered in this supplement shall be included in the original quotation and the supplement will be considered one of the contract documents.
- B. Contractors, Manufacturers and/ or Distributors shall confirm the receipt and consideration of this addendum prior to the submittal of their proposal by noting inclusion of addendum one on the Contractor's Proposal.

II. PURPOSE OF ADDENDUM:

- A. Electrical coordination clarifications.

III. CONTENT:

1. The P.V. module was changed from the Solon 230/ 15 to the SolarWolrd SunModule SW45 Mono. The new module will have a shorter lead time and is less expensive. It will also raise the power production. See sheet E1.0 for PV module specs.
2. The wiring of the P.V. modules was re arranged to provide balance between the three phases. See attached ESK1.0.

IV. ATTACHMENTS:

SEE FOLLOWING PAGE.

© MRC ENGINEERING, INC. 2009 - Plotted December 30, 2010 - 03:32 pm - File Path & Name: Y:\COUNTY OF RIVERSIDE\PROJECTS\NEW DESIGN\1049.D00 CAC PARKING\WD\ESD SOLAR STRUCTURE.DWG

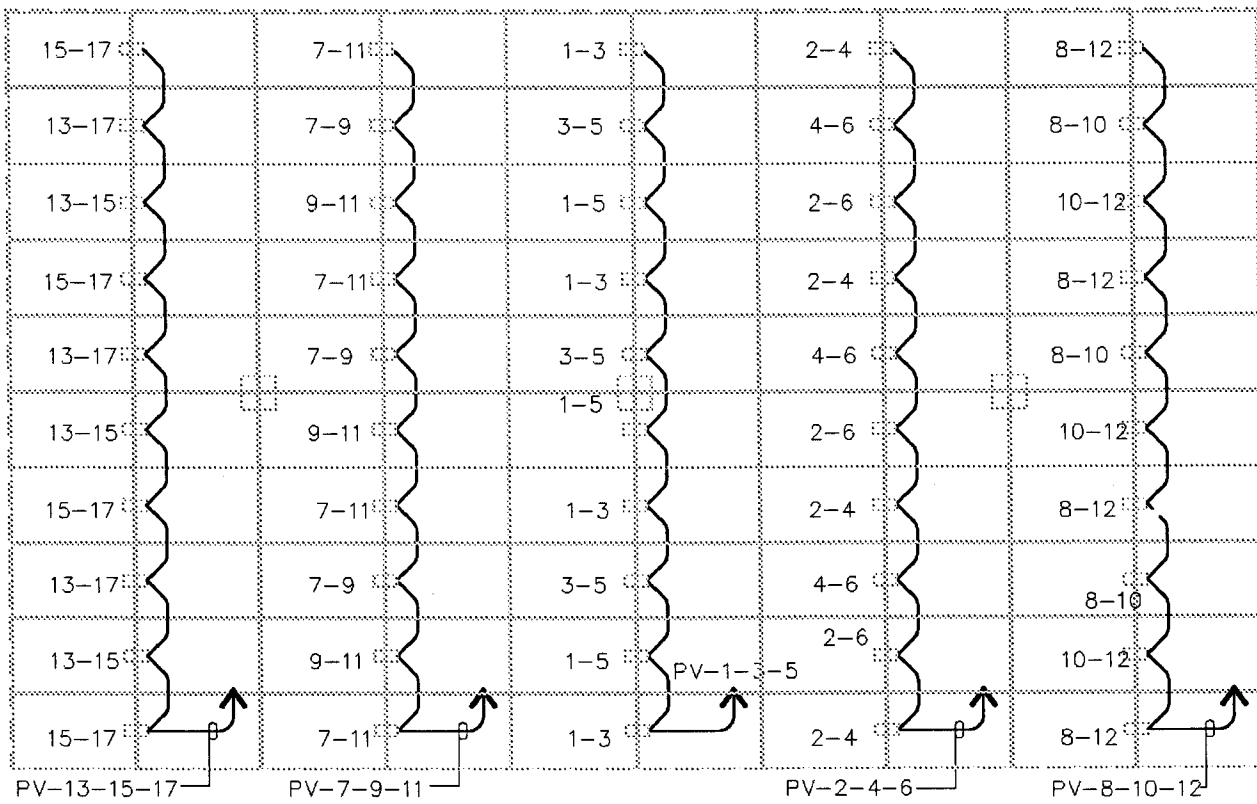

PANEL: PV				PANEL VOLTAGE: 120/208 3P, 4W				CIRCUIT CODE: N: NON-CONTINUOUS							
LOCATION: SOLAR CARPORT				BUS: 100A				L: LONG-CONTINUOUS							
MOUNTING: SURFACE				MAIN: 80A				R: DEMANDABLE RECEPTACLES							
				AIC RATING: 10,000				K: KITCHEN							
CIRC	VA LOAD			LOAD DESCRIPTION	C.B.	TYPE	BUS	C.B.	TYPE	CODE	LOAD DESCRIPTION	VA LOAD			CIRC
	A	B	C									A	B	C	
1	1520			ENPHASE #0380 INVERTERS	N		20 3	X		N	ENPHASE #0380 INVERTERS	1520			2
3		1140			N			X		N			1140		4
5			1140		N			X		N				1140	6
7	1140			ENPHASE #0380 INVERTERS	N		20 3	X		N	ENPHASE #0380 INVERTERS	1140			8
9		1520			N			X		N			1520		10
11			1140		N			X		N				1140	12
13	1140			ENPHASE #0380 INVERTERS	N		20 3	X		N	SPACE				14
15		1140			N			X		N	SPACE				16
17			1520		N			X		N	SPACE				18
19				SPACE				X		N	SPACE				20
21				SPACE				X		N	SPACE				22
23				SPACE				X		N	SPACE				24
3800 3800 3800			PHASE TOTALS			PHASE TOTALS			2660 2660 2280						
Total Phase A: 5460				CONNECTED VA (CODE N):				19000							
Total Phase B: 5480				CONNECTED VA (CODE L):											
Total Phase C: 6080				CONNECTED VA (CODE R):											
				CONNECTED VA (CODE K):											
				TOTAL CONNECTED KVA:				19.0							
				DEMAND KVA:											
				TOTAL ADJUSTED KVA:				19.0							
				TOTAL PANEL AMPS:				52.8							
				AMPS W/CL:				52.8							

NOTES:

**M|R|C**  
ENGINEERING, INC  
Professional Engineers & Lighting Consultants  
Palm Desert | Irvine | San Diego  
72880 Fred Waring Drive, Suite C  
Palm Desert, CA 92260  
Tel: 760-340-9005 Fax: 760-340-9100



PROJECT NAME:  
**CAC PARKING STRUCTURE**  
4090 LEMON STREET  
RIVERSIDE, CA 92501  
DRAWING TITLE:  
**BALANCED PANEL SCHEDULES**

SCALE: NTS  
PROJECT NO.: 1049.00  
DATE: 12/06/10  
ADDENDUM NO.: 1  
DERIVED FROM: E3.0  
SHEET:  
**ESK1.0**



----- Palm Desert | Santa Ana | San Diego

----- END -----





..... Palm Desert | Santa Ana | San Diego

Date: December 30, 2010  
 Project: CAC Parking Structure Solar Project  
 Project No.: FM0672000027  
 Addendum: **NUMBER TWO**

I. INSTRUCTIONS:

- A. This supplement to the bid package is issued prior to the receipt of proposals. All changes covered in this supplement shall be included in the original quotation and the supplement will be considered one of the contract documents.
- B. Contractors, Manufacturers and/ or Distributors shall confirm the receipt and consideration of this addendum prior to the submittal of their proposal by noting inclusion of addendum two on the Contractor's Proposal.

II. PURPOSE OF ADDENDUM:

- A. To respond to all RFI's to issued construction documents dated 11-05-10 RFI's.

III. RFI'S AND ANSWERS:

**1. RIS ELECTRICAL CONTRACTORS #3.**

Question:

Per the note on S-2 and S-3, the concrete columns are to be tested. What percentage of the columns need to be tested and by what methods?

Answer:

All columns are to be tested. Use X-RAY, sonogram or other tests to establish: size of column, strength of concrete, size and location of reinforcement.

**2. PACWEST CONSTRUCTION. 12/23/10 EMAIL.**

Questions:

- a. Do you require good faith effort of DVBE for this project? If so, how many percent is the goal?  
 b. Also, what are the documents that should be submitted with the bid?

Answers:

- a. This project does not have a specific requirement for DVBE participation.  
 b. All forms are part and contained in the document: " SPECIFICATIONS AND CONTRACT DOCUMENTS FOR US DEPARTMENT OF ENERGY - SOLAR PROJECTS. CAC PARKING STRUCTURE SOLAR SYSTEM AND



Palm Desert | Santa Ana | San Diego

LIGHTING UPGRADE FM0672000027". This document is part of the Bid documents and is available at Mission Reprographics.

### 3. QUALITY IRON. 12/22/10 EMAIL.

Question:

Is a requirement that the Steel Subcontractor be AISC certified?

Answer:

Yes.

### 4. GEORGE HALABIAN. 12/27/10 EMAIL.

Question:

We just want to make sure and confirm with you, regarding the documents that should be submitted with the bid, are these the following docs, since it is not listed in the instruction to bidders nor the specs:

1. Contractor's proposal.
2. Designation of Subcontractors.
3. Award of Contract/ Bid Guarantee.
4. Non Collusion Affidavit.
5. Bid Bond.

Is there anything else, what about the Contractor's Certificate regarding worker's compensation, should we submit that too with the bid documents.

Answer:

All forms are part and contained in the document: "SPECIFICATIONS AND CONTRACT DOCUMENTS FOR US DEPARTMENT OF ENERGY - SOLAR PROJECTS. CAC PARKING STRUCTURE SOLAR SYSTEM AND LIGHTING UPGRADE FM0672000027". This document is part of the Bid documents and is available at Mission Reprographics.

### 5. WEST COAST IRON, INC. 12/23/10 EMAIL.

Questions:

- a. Please confirm access that will be available for staging a truck crane for hoisting steel components to the top level of the parking deck. Ideally, the area of on-grade parking, at the parking lot off of Lemon Street and 12<sup>th</sup> Street, should be partially accessible for at least a week, to allow for hoisting of components. The area closest to the parking deck, which parks about 26 cars, would need to be



..... Palm Desert | Santa Ana | San Diego

available for a few hours each morning (7:00 AM to 10:00 AM), to allow for hoisting. Can you confirm that this area will be available?

b. Are As-Built drawings available for the parking deck?

c. The Framing Plan on Sheet S-2 and Details 3 and 4 on Sheet S-3 call for "3HU3x105 Galvanized Hat Channel Runners". We have been unable to locate this product. Can you provide the specific procurement details for this product or can you provide an alternate module mounting solution?

d. Detail 11 on Sheet S-3, Plan View A, appears to indicate 3" x 3" square washers, or perhaps weld washers; however, there is not a call-out on the drawings. Can you clarify?

Answers:

a. The final staging area will be coordinated with the contractor prior to work.

b. No.

c. See attached detail (CACRF15.c) for Hat channel dimensions and Manufacturer. We are also open to alternatives.

d. 3" x 3" plates are not needed and can be omitted.

#### 6. ORR BUILDERS #1.

Questions:

a. Reference: Electrical Drawing Sheet E1.1, Paragraph 2.11, C, Carport Structure: Please provide paint specification and paint manufacture and number of coats.

b. Reference: Electrical Drawing Sheet E1.2: What is the thickness of the existing asphalt paving and aggregate base that needs to be replaced for the electrical underground conduits.

Answers:

a. Paints to be: Dunn-Edwards, Benjamin Moore & CO., Pratt & Lambert Paints, Sherwin William, Approved equal. First coat: S-W Pro-Cryl Universal Metal Primer B66-310 series (110 g/l VOC); second coat: S-W SoloGloss Acrylic Semigloss B21WJ8651 (48 g/l VOC); third and last coat: S-W SoloGloss Acrylic Semigloss B21WJ8651 (48 g/l VOC).

b. This item needs to be field verified during construction.

#### IV. JOB WALK QUESTIONS TO BE CLARIFIED:

1.

Question:

Alternate #1 regarding type of Halide Light Fixture to be replaced.



Palm Desert | Santa Ana | San Diego

Answer:

See attached picture (CACJWQ1) of existing Halide Fixture to be replaced. Existing fixtures are to be replaced on base bid and also on Alternate Bid #1. Refer to lighting fixture schedule on sheet C1.0 for fixture type #2. KIM lighting fixtures are to be used to replace all existing fixture on Base Bid. LSI fixtures are to be used to replace all existing fixture on Alternate Bid #1.

2.

Question:

Operating hours for the trenching portion of the project:

Answer:

Normal business hours, unless noted otherwise.

3.

Question:

TEL-COMMties at which room?

Answer:

See sheet E1.2, communication run.

#### V. FOR CLARIFICATION:

1. The structure for the solar panel canopies are to be shop and field fabricated in accordance with the framing and foundation plans, structural details and typical notes. These structures are not intended to be prefabricated units.
2. All "copper" terminations to the aluminum solar module frame for grounding must be done with a Tyco Electronics "Solklamp Ground Bolt" or equal.
3. The contractor shall coordinate all inspections with the county inspector and provide all concrete compression testing as required.
4. The contractor shall provide an estimated draft work schedule with the Bid Price submittal.
5. The contractor is responsible for the removal of the existing railing during the installation of the new structures and re-install when completed. Provide temporary protective rails during the construction process.
6. Provide galvanized seamless couplings and connectors (compression type) with factory applied insulated throat. Devices shall be used in accordance with the article 348-electrical metallic tubing. Set screw connectors are not approved.



Palm Desert | Santa Ana | San Diego

7. The structural steel canopies shall be shop primed and painted as recommended by the paint manufacture for exterior ferrous metal and a minimum of 3 coats.
8. Existing shade structures shall be disassembled and stored on site. The location shall be coordinate with the County Project Manager: Bruce Norris.
9. Provide an Alternate Bid Price "Maintenance" that will cover the maintenance program as described on sheet E1.1 part 1 general note 2.4 b (maintenance to include 3 site visits per year for 4 years for the testing and cleaning of the solar equipment).
10. About the time frame of completion for this project, the intent is to allow 90 days for delivery of materials and 60 days for construction. The contractor and trades can start work within the 90 day material period, however, the bonded period should not exceed 60 construction days, and the total project period should not exceed 150 days. The contractor shall provide an estimated draft work schedule with the Bid Price submittal.
11. Shop Drawings & Substitutions. The contractor is required to bid the specified products. If an alternate product is being proposed the contractor shall submit the bid price as an "Alternate Bid Price" for that item.
12. No central inverters will be considered for this project. If another micro-inverter is available the contractor shall submit a bid price as an "Alternate Bid Price" for that item and follow the requirements of the Notes on sheet E1.1 "Shop Drawings & Substitutions".
13. Neutral wire was added from solar distribution panel DPV to Main Switchboard. See attached revised single line diagram (CACCLA13).

#### VI. ATTACHMENTS:

SEE FOLLOWING PAGE.

HAT CHANNELS ARE AVAILABLE AT:  
 JOHNSON BROTHERS METAL FORMING CO.  
 5520 MCDERMOTT DRIVE  
 BERKLEY, IL 60163-1203  
 TEL: (708)449-7050  
 FAX: (708)449-0042  
 WWW.JOHNSONROLLFORMING.COM

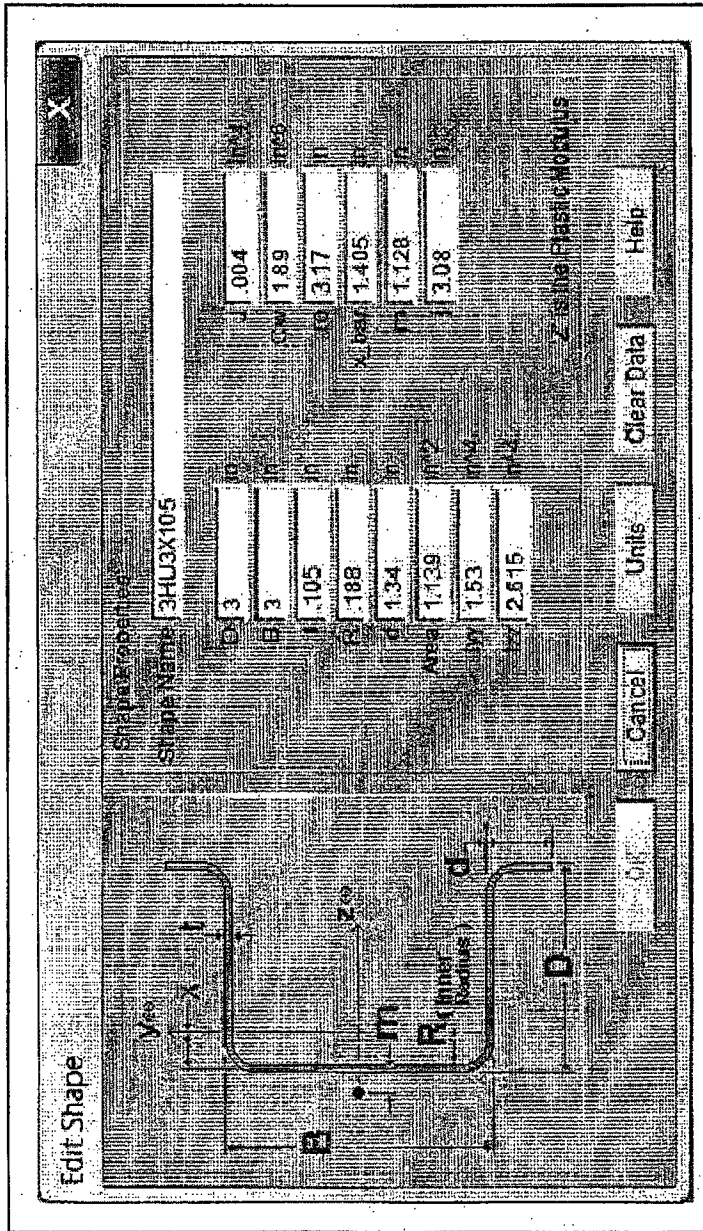

Attachment  
CACRFI5.c

Attachment  
CACJWQ1

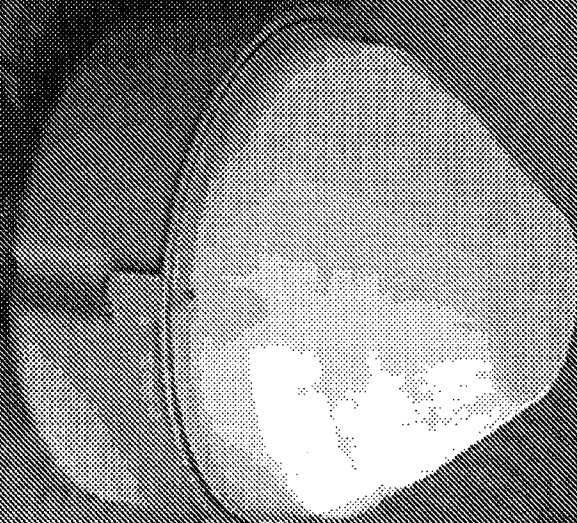

MIRC ENGINEERING, INC. 2009 - Plotted December 30, 2010 - 03:43 pm - File Path & Name: Y:\COUNTY OF RIVERSIDE\DOE SOLAR PROJECT\NEW DESIGN\104900 CAC PARKING\WDV340 SOLAR STRUCTURE.DWG

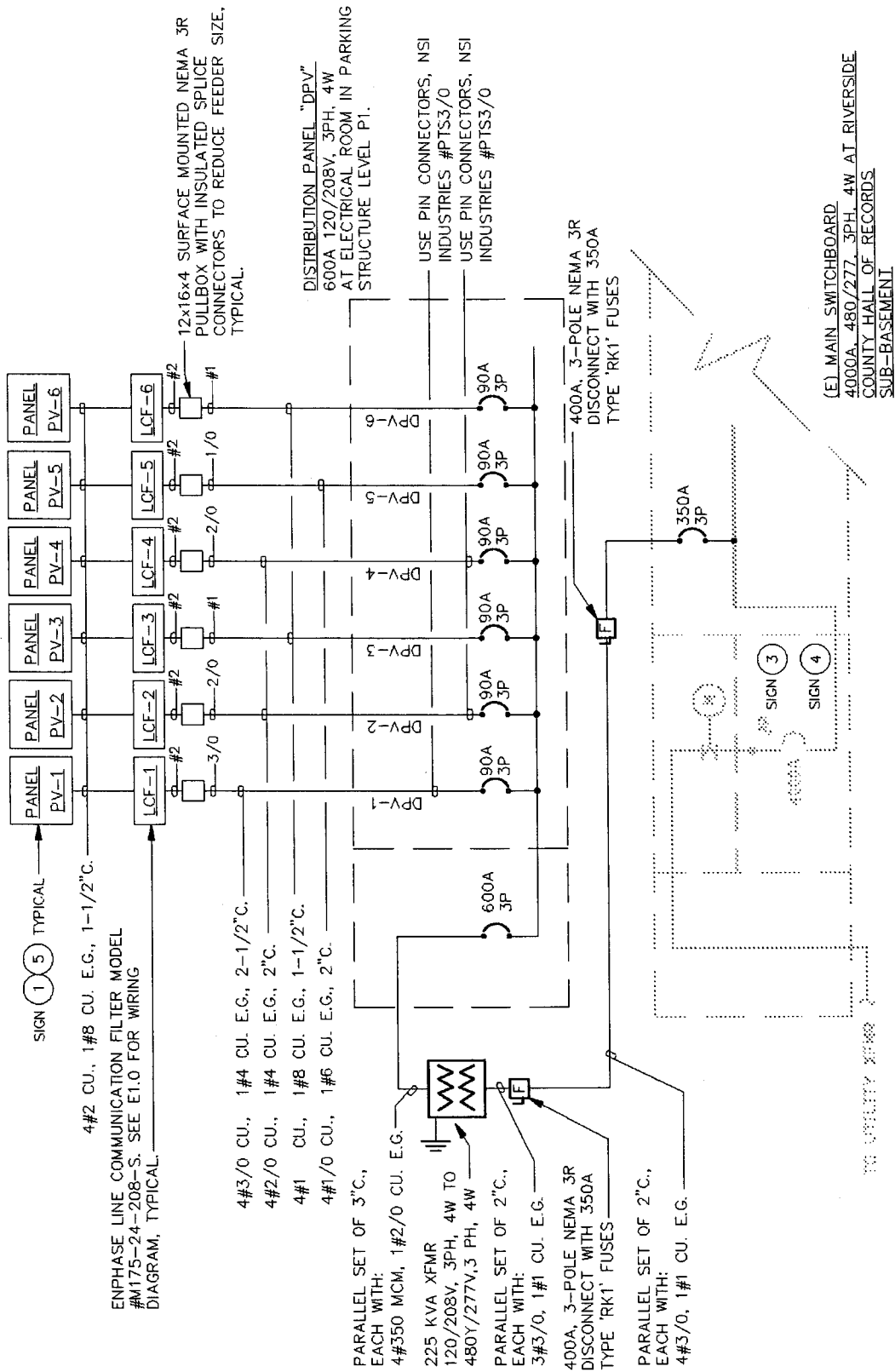

**M|R|C**  
ENGINEERING, INC  
Professional Engineers & Lighting Consultants

Palm Desert | Irvine | San Diego  
7280 Fred Weberg Drive, Suite C  
Palm Desert, CA 92260  
Tel: 760-340-9005 F: 760-340-9190

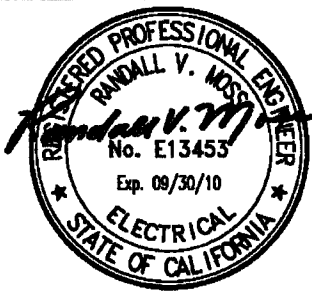

PROJECT NAME:  
**CAC PARKING STRUCTURE**  
4090 LEMON STREET  
RIVERSIDE, CA 92501

DRAWING TITLE:  
**REVISED SINGLE LINE DIAGRAM**

SCALE:	NTS
PROJECT NO.:	1049.00
DATE:	12/30/10
ADDENDUM NO.:	2
DERIVED FROM:	E3.0

SHEET:  
**CACCLA13**





----- Palm Desert | Santa Ana | San Diego

-----END-----

# County of Riverside

## REBID - CAC Parking Structure Solar System & Lighting Upgrade Addendum 3

**To:** Erin Wilson  
NBI General Contractors, Inc. 3 Sets  
1770 Howard Place  
Redlands, California , 92373

**Phone:** 909-798-7300  
**Fax:** 909-798-7340  
**Email:** erin@nbigc.com

**From:** Mario Silva  
Mission Reprographics

**Phone:** 951-686-8828  
**Fax:** 951-686-7747  
**Email:** planwell@missionreprographics.com

Gentlemen:

We've attached Addendum 3 for the bid documents you've purchased. Add the following files to the end of your bid docs.

Please download Addendum 3 for your bid project:  
**CAC Add 3.pdf**

**[Click here to view and order plans online, using PlanWell.](#)**

If you've only received the fax, please call 951-686-8828 and request Addendum 3 to be emailed to you.

**[Click here to acknowledge receipt of Addendum 3 and confirm your firm will submit a qualified bid.](#)**

**Note:** Please do not delete this email until after the bid due date...It will be used in the future to directly access additional plans, specs and addendum that may change and digitally view them free of charge.

Should there be any questions regarding your bid, feel free to contact Bruce Norris with the County of Riverside at 951-955-0353.  
Thank you in advance for your willingness to consider this project.

Sincerely,

Mario Silva



Palm Desert | Santa Ana | San Diego

Date: January 3, 2011  
Project: CAC Parking Structure Solar Project  
Project No.: FM0672000027  
Addendum: **NUMBER THREE**

I. INSTRUCTIONS:

- A. This supplement to the bid package is issued prior to the receipt of proposals. All changes covered in this supplement shall be included in the original quotation and the supplement will be considered one of the contract documents.
- B. Contractors, Manufacturers and/ or Distributors shall confirm the receipt and consideration of this addendum prior to the submittal of their proposal by noting inclusion of addendum three on the Contractor's Proposal.

II. PURPOSE OF ADDENDUM:

- A. The purpose of this addendum is to provide all bidders with notice of the extension of the bid date.
- B. **The bid date is hereby extended to Wednesday, January 12, 2011, at 14:00 hrs. (2:00 PM). See attached Notice Inviting Bids document from the County of Riverside.**

III. CHANGES AND CLARIFICATIONS:

1. STRCUTURAL DETAIL #3 ON SHEET S-3.

The Hat Channel Runners material was changed to aluminum to prevent corrosion issues. The attachment from solar module to steel beam specification is as follows: UNIRAC Solar Mount-I Series Sider with Md Clamp or equal.

-----END-----

**NOTICE INVITING BIDS**

COUNTY OF RIVERSIDE, herein called Owner, invites sealed proposals for:

**US Depart. Of Energy's Solar Projects  
CAC Parking Structure Solar System & Lighting Upgrade**

This Project is to build & install a 110KW solar system on the top level of the CAC Parking structure & Upgrade the existing structure Lighting, located at 4090 Lemon Street, Riverside, CA 92501 per plans and specifications. Project is Estimated at \$1,248,700.00

Proposals shall be delivered to the Clerk of the Board, on the 1st floor of the Riverside County Administration Center located at 4090 Lemon Street, Riverside, CA 92501, no later than 2:00 pm on January 12<sup>th</sup>, 2011 and will be promptly opened in public at said address.

Each Proposal shall be in accordance with the Plans, Specifications, and other Contract Documents prepared by MRC Engineering. Plans and Specifications may be obtained from Mission Reprographics, 2050E. La Cadena Drive Suite L Riverside, CA 92507, 951-686-8828, for a nonrefundable fee of (\$30.00). An additional nonrefundable fee will be charged for each set of Plans and Specifications furnished that are requested to be mailed to Contractors.

Pursuant to the Labor Code, obtained from the Director of the *Department of Industrial Relations, State of California*, and his determination of the general prevailing rates of per diem wages applicable to the work, and for holiday and overtime work, including employer payments for health and welfare, pension, vacation, and similar purposes, as set forth on the schedule, copies of which are on file at the Clerk of the Board of Supervisors, 4090 Lemon St., 1<sup>st</sup> floor, Riverside, CA 92501-3655.

**NOTE:** The County of Riverside will be using the Davis Bacon prevailing wage rates of per diem wages applicable to the work, or whichever is the higher rate.

A Bid Bond, Performance Bond and Payment Bond shall be required for this Project. The Contract General Conditions for this project will contain provisions allowing the successful contractor to substitute securities for monies withheld by the County to ensure performance (Public Contract Code 22300).

The Contractor will be required, per Public Contracts Code, Section 3300 and for this contract, to have a State of California contractor's license classification "B" General Contractors license.

Mandatory pre-bid job walk inspection will be held on December 20<sup>th</sup>, 2010 starting at 09:00 Am., we will meet on the upper level of the CAC parking structure at 4090 Lemon St., Riverside, CA 92501.

**No bids will be accepted from bidders who have not attended the pre-bid job walk.**

For additional information, contact Bruce Norris at the Economic Development Agency, located at 3403 10<sup>th</sup> St., Riverside, CA 92501, whose telephone number is (951) 955-0353.

STATE OF CALIFORNIA

**Contractors State License Board**

Pursuant to Chapter 9 of Division 3 of the Business and Professions Code and the Rules and Regulations of the Contractors State License Board, the Registrar of Contractors does hereby issue this license to:

**N B I GENERAL CONTRACTORS INC**

License Number 435915

to engage in the business or act in the capacity of a contractor in the following classification(s):

- B - GENERAL BUILDING CONTRACTOR
- A - GENERAL ENGINEERING CONTRACTOR

Witness my hand and seal this day,

September 29, 2010

**Issued March 2, 1983**

Reissued September 6, 2007

This license is the property of the Registrar of Contractors, is not transferable, and shall be returned to the Registrar upon demand when suspended, revoked, or invalidated for any reason. It becomes void if not renewed.

James Miller  
Board Chair

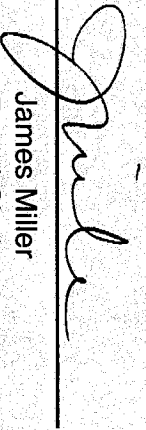

Stephen P. Sands  
Registrar of Contractors





State Of California  
**CONTRACTORS STATE LICENSE BOARD**  
**ACTIVE LICENSE**



License Number

**435915**

Entity **CORP**

Business Name

**N B I GENERAL CONTRACTORS INC**

Classification(s) **B A**

Expiration Date

**09/30/2011**

[www.cslb.ca.gov](http://www.cslb.ca.gov)





# CERTIFICATE OF LIABILITY INSURANCE

OP ID JK  
NBIGE-1

DATE (MM/DD/YYYY)

11/01/10

<b>PRODUCER</b>  Andrew R. Smith Ins. Svs., Inc. 1200 California St., Ste. 112 Redlands CA 92374 Phone: 909-793-4085 Fax: 909-793-5316		THIS CERTIFICATE IS ISSUED AS A MATTER OF INFORMATION ONLY AND CONFERS NO RIGHTS UPON THE CERTIFICATE HOLDER. THIS CERTIFICATE DOES NOT AMEND, EXTEND OR ALTER THE COVERAGE AFFORDED BY THE POLICIES BELOW.	
<b>INSURED</b>  NBI General Contractors, Inc. P.O. Box 8580 Redlands CA 92375		<b>INSURERS AFFORDING COVERAGE</b>	<b>NAIC #</b>
		INSURER A: Mt. Hawley Insurance Company	
		INSURER B: Golden Eagle Insurance Corp.	
		INSURER C: Topa Insurance Company	
		INSURER D:	
		INSURER E:	

### COVERAGES

THE POLICIES OF INSURANCE LISTED BELOW HAVE BEEN ISSUED TO THE INSURED NAMED ABOVE FOR THE POLICY PERIOD INDICATED. NOTWITHSTANDING ANY REQUIREMENT, TERM OR CONDITION OF ANY CONTRACT OR OTHER DOCUMENT WITH RESPECT TO WHICH THIS CERTIFICATE MAY BE ISSUED OR MAY PERTAIN, THE INSURANCE AFFORDED BY THE POLICIES DESCRIBED HEREIN IS SUBJECT TO ALL THE TERMS, EXCLUSIONS AND CONDITIONS OF SUCH POLICIES. AGGREGATE LIMITS SHOWN MAY HAVE BEEN REDUCED BY PAID CLAIMS.

INSR ADD'L LTR	INSRD	TYPE OF INSURANCE	POLICY NUMBER	POLICY EFFECTIVE DATE (MM/DD/YYYY)	POLICY EXPIRATION DATE (MM/DD/YYYY)	LIMITS
A		GENERAL LIABILITY	MGL0170596	08/17/10	08/17/11	EACH OCCURRENCE \$ 1,000,000
		<input checked="" type="checkbox"/> COMMERCIAL GENERAL LIABILITY				DAMAGE TO RENTED PREMISES (Ea occurrence) \$ 50,000
		<input type="checkbox"/> CLAIMS MADE <input checked="" type="checkbox"/> OCCUR				MED EXP (Any one person) \$ 5,000
		GEN'L AGGREGATE LIMIT APPLIES PER:				PERSONAL & ADV INJURY \$ 1,000,000
		<input type="checkbox"/> POLICY <input checked="" type="checkbox"/> PROJECT <input type="checkbox"/> LOC				GENERAL AGGREGATE \$ 2,000,000
						PRODUCTS - COMP/OP AGG \$ 2,000,000
B		AUTOMOBILE LIABILITY	BA1377174	08/17/10	08/17/11	COMBINED SINGLE LIMIT (Ea accident) \$ 1,000,000
		<input checked="" type="checkbox"/> ANY AUTO				BODILY INJURY (Per person) \$
		<input type="checkbox"/> ALL OWNED AUTOS				BODILY INJURY (Per accident) \$
		<input type="checkbox"/> SCHEDULED AUTOS				PROPERTY DAMAGE (Per accident) \$
		<input type="checkbox"/> HIRED AUTOS				
		<input type="checkbox"/> NON-OWNED AUTOS				
		GARAGE LIABILITY				AUTO ONLY - EA ACCIDENT \$
		<input type="checkbox"/> ANY AUTO				OTHER THAN EA ACC \$
						AUTO ONLY: AGG \$
C		EXCESS / UMBRELLA LIABILITY	XL6601589	08/17/10	08/17/11	EACH OCCURRENCE \$ 4,000,000
		<input checked="" type="checkbox"/> OCCUR <input type="checkbox"/> CLAIMS MADE				AGGREGATE \$ 4,000,000
		<input type="checkbox"/> DEDUCTIBLE				\$
		<input type="checkbox"/> RETENTION \$				\$
		WORKERS COMPENSATION AND EMPLOYERS' LIABILITY				WC STATUTORY LIMITS
		ANY PROPRIETOR/PARTNER/EXECUTIVE OFFICER/MEMBER EXCLUDED? (Mandatory in NH)				OTHER
		If yes, describe under SPECIAL PROVISIONS below				E.L. EACH ACCIDENT \$
		OTHER				E.L. DISEASE - EA EMPLOYEE \$
						E.L. DISEASE - POLICY LIMIT \$

DESCRIPTION OF OPERATIONS / LOCATIONS / VEHICLES / EXCLUSIONS ADDED BY ENDORSEMENT / SPECIAL PROVISIONS

\*10 Day notice for non-payment of premium. Verification of Insurance.

### CERTIFICATE HOLDER

<b>INSURED</b>  Issued to Insured
---

### CANCELLATION

SHOULD ANY OF THE ABOVE DESCRIBED POLICIES BE CANCELLED BEFORE THE EXPIRATION DATE THEREOF, THE ISSUING INSURER WILL ENDEAVOR TO MAIL 30* DAYS WRITTEN NOTICE TO THE CERTIFICATE HOLDER NAMED TO THE LEFT, BUT FAILURE TO DO SO SHALL IMPOSE NO OBLIGATION OR LIABILITY OF ANY KIND UPON THE INSURER, ITS AGENTS OR REPRESENTATIVES.
AUTHORIZED REPRESENTATIVE <i>Jeanie Kyschak</i>



P.O. BOX 420807, SAN FRANCISCO, CA 94142-0807

## CERTIFICATE OF WORKERS' COMPENSATION INSURANCE

ISSUE DATE: 01-01-2011

GROUP: 000713  
 POLICY NUMBER: 0008756-2010  
 CERTIFICATE ID: 65  
 CERTIFICATE EXPIRES: 01-01-2012  
 01-01-2011/01-01-2012

CONTRACTORS STATE LICENSE BOARD  
 WORKERS COMPENSATION UNIT  
 PO BOX 26000  
 SACRAMENTO CA 95826-0026

SJ

LIC PERMIT#: 435915  
 INCEPTION DATE: 01-01-2011  
 DO: SJ

This is to certify that we have issued a valid Workers' Compensation insurance policy in a form approved by the California Insurance Commissioner to the employer named below for the policy period indicated.

This policy is not subject to cancellation by the Fund except upon 30 days advance written notice to the employer.

We will also give you 30 days advance notice should this policy be cancelled prior to its normal expiration.

This certificate of insurance is not an insurance policy and does not amend, extend or alter the coverage afforded by the policy listed herein. Notwithstanding any requirement, term or condition of any contract or other document with respect to which this certificate of insurance may be issued or to which it may pertain, the insurance afforded by the policy described herein is subject to all the terms, exclusions, and conditions, of such policy.

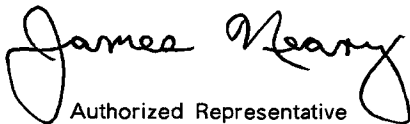
  
 Authorized Representative

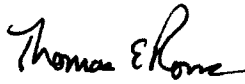
  
 President and CEO

EMPLOYER'S LIABILITY LIMIT INCLUDING DEFENSE COSTS: \$1,000,000 PER OCCURRENCE.

ENDORSEMENT #2065 ENTITLED CERTIFICATE HOLDERS' NOTICE EFFECTIVE 01-01-2004 IS ATTACHED TO AND FORMS A PART OF THIS POLICY.

EMPLOYER

N B I GENERAL CONTRACTORS INC  
 PO BOX 8580  
 REDLANDS CA 92375

SJ





General Contractors, Inc.

NBI GENERAL CONTRACTORS, INC.  
James P. O'Hara, President  
1770 Howard Place  
Redlands, CA. 92373  
(909)798-7300  
CSLB #435915, Class A, B

SEALED BID RECEIVED  
CLERK OF THE BOARD OF SUPERVISORS

RECEIVED RIVERSIDE COUNTY  
CLERK / BOARD OF SUPERVISORS  
2011 JAN 12 PM 1:36

County of Riverside  
Clerk of the Board  
4080 Lemon Avenue  
First Floor  
Riverside, CA. 92501

SEALED BID PROPOSAL FOR:  
CAC Parking Structure Solar System  
& Lighting Upgrade

BID DATE:  
Wednesday, January 5, 2011 @ 2:00pm

Post Office Box 8580, Redlands, CA 92375 • 1770 Howard Place, Redlands, CA 92373  
Phone (909) 798-7300 • Fax (909) 798-7340 • License 435915

**CONTRACTOR'S PROPOSAL    CAC Parking Structure**

TO THE GOVERNING BOARD OF THE COUNTY OF RIVERSIDE:

Date: 1/12/11

Bidder: Stronghold Engineering, Inc.

The undersigned, having carefully examined the proposed site and the Plans and Specifications, the Notice Inviting Bids, the Instructions to Bidders, the Agreement Form, the Bond Forms, the General Conditions for the Construction of the CAC Parking Structure Solar System & Lighting Upgrade, hereby proposes and agrees to furnish all tools, equipment, services, apparatus, facilities, transportation, labor and materials necessary to complete the work in strict conformity with the Plans and Specifications, including all work specified in Addenda numbered and dated:

Addendum No. 01 Date 12/6/10

Addendum No. 02 Date 12/30/10

Addendum No. 03 Date 1/3/11

For the total Base Bid One Million, Three Hundred and Eighty Three Thousand One Hundred Dollars and No Cents One Hundred Dollars and No Cents dollars (\$ 1,383,100.00 ), including all applicable taxes, permits, licenses, **AND Course of Construction Insurance.**

		(Add or Deduct state which)
Alternate 1	\$ <u>10,000.00</u>	<u>Deduct</u>
Alternate 2	\$ _____	_____
Alternate 3	\$ _____	_____
Alternate 4	\$ _____	_____

And,  
Cost of Contractor's Course of Construction Insurance \_\_\_\_\_ dollars (\$ 4,000.00 )  
and deductible \$ 2,500.00.

Bids must be submitted on all items. Failure to bid on all items may result in the bid being rejected as non-responsive. The basis for award will be the qualified bidder with the lowest total of the Base Bid WITH COURSE OF CONSTRUCTION INSURANCE and all alternates. Alternates may be awarded in any order after determination of the lowest responsible and responsive bidder.





**Bid Bond**

KNOWN TO ALL MEN BY THESE PRESENTS, that we, the undersigned Stronghold Engineering Incorporated, as Principal; and Safeco Insurance Company of America, as Surety, are hereby held and firmly bound unto the County of Riverside, hereinafter called the "Owner", in the sum of Ten Percent of the Total Amount Bid Dollars (\$ 10% ) for the payment of such sum, well and truly to be made, do hereby jointly and severally bind ourselves, our heirs, executors, administrators, successors and assigns.

WHEREAS, the said Principal is herewith submitting its Proposal for the US DEPARTMENT of ENERGY - SOLAR PROJECTS  
CAC Parking Structure Solar System & Lighting Upgrade - FM0672000027

---

THE CONDITION OF THE ABOVE OBLIGATION IS SUCH, that if the aforesaid Principal shall be awarded the Contract upon said Proposal and shall, within the required number of days after the notice of such award, execute a written memorial of the awarded Contract and submit the required Labor and Material Payment and faithful Performance Bond and proof of insurance, then this obligation shall be null and void; and in the event that the Principal fails and/or refuses to execute and deliver said documents this Bond will be charged with the costs of the damages experienced by the Owner as a result of such refusal, including but not limited to, publication cost, the difference in money between the amount of the bid of the said Principal and the amount for which the obligee may legally contract with another party to perform the said work if such amount be in excess of the former; building lease or rental costs, transportation cost, and additional salary costs that result from the delay due to the Principal's default on the awarded Contract. In no event however, shall the Surety's liability exceed the penal sum hereof.

The Surety, for value received, hereby stipulates and agrees that the obligations of said Surety and its bond shall be in no way impaired or affected by any extension of the time within which the Owner may accept such bid; and said Surety does hereby waive notice of any such extension.

IN WITNESS WHEREOF, the above bounded parties have executed this instrument under their separate seals this 22nd day of December, 2010, the name and corporate seal of each corporate party being hereto affixed and those present duly signed by its undersigned representative, pursuant to authority of its governing body.

Stronghold Engineering Incorporated  
(Firm Name - Principal)

2000 Market Street, Riverside, CA 92501  
(Business Address)

By [Signature]  
(Original Signature)

(Title)

Safeco Insurance Company of America  
(Corporation Name - Surety)

330 N. Brand Blvd., Suite 680, Glendale, CA 91203  
(Business Address)

By [Signature]  
(Original Signature) Jennifer L. Cox, Attorney-in-Fact

Affix Seal  
If  
Corporation

Affix  
Corporate  
Seal

POWER  
OF ATTORNEY

No. 9979

KNOW ALL BY THESE PRESENTS:

That **SAFECO INSURANCE COMPANY OF AMERICA** and **GENERAL INSURANCE COMPANY OF AMERICA**, each a Washington corporation, does each hereby appoint

\*\*\*\*\***GERRIT E. BROUWER; JEFFREY W. CAVIGNAC; JENNIFER L. COX; JAMES P. SCHABARUM, II; JANIS THEODORE; San Diego, California**\*\*\*\*\*

its true and lawful attorney(s)-in-fact, with full authority to execute on its behalf fidelity and surety bonds or undertakings and other documents of a similar character issued in the course of its business, and to bind the respective company thereby.

**IN WITNESS WHEREOF, SAFECO INSURANCE COMPANY OF AMERICA and GENERAL INSURANCE COMPANY OF AMERICA have each executed and attested these presents**

this 23rd day of June, 2010

*Dexter R. Legg*

*T. Mikolajewski*

**Dexter R. Legg, Secretary**

**Timothy A. Mikolajewski, Vice President**

**CERTIFICATE**

Extract from the By-Laws of **SAFECO INSURANCE COMPANY OF AMERICA**  
and of **GENERAL INSURANCE COMPANY OF AMERICA**:

"Article V, Section 13. - FIDELITY AND SURETY BONDS ... the President, any Vice President, the Secretary, and any Assistant Vice President appointed for that purpose by the officer in charge of surety operations, shall each have authority to appoint individuals as attorneys-in-fact or under other appropriate titles with authority to execute on behalf of the company fidelity and surety bonds and other documents of similar character issued by the company in the course of its business... On any instrument making or evidencing such appointment, the signatures may be affixed by facsimile. On any instrument conferring such authority or on any bond or undertaking of the company, the seal, or a facsimile thereof, may be impressed or affixed or in any other manner reproduced; provided, however, that the seal shall not be necessary to the validity of any such instrument or undertaking."

Extract from a Resolution of the Board of Directors of **SAFECO INSURANCE COMPANY OF AMERICA**  
and of **GENERAL INSURANCE COMPANY OF AMERICA** adopted July 28, 1970.

"On any certificate executed by the Secretary or an assistant secretary of the Company setting out,

- (i) The provisions of Article V, Section 13 of the By-Laws, and
- (ii) A copy of the power-of-attorney appointment, executed pursuant thereto, and
- (iii) Certifying that said power-of-attorney appointment is in full force and effect,

the signature of the certifying officer may be by facsimile, and the seal of the Company may be a facsimile thereof."

I, **Dexter R. Legg**, Secretary of **SAFECO INSURANCE COMPANY OF AMERICA** and of **GENERAL INSURANCE COMPANY OF AMERICA**, do hereby certify that the foregoing extracts of the By-Laws and of a Resolution of the Board of Directors of these corporations, and of a Power of Attorney issued pursuant thereto, are true and correct, and that both the By-Laws, the Resolution and the Power of Attorney are still in full force and effect.

**IN WITNESS WHEREOF, I have hereunto set my hand and affixed the facsimile seal of said corporation**

this 22nd day of December, 2010



*Dexter R. Legg*

**Dexter R. Legg, Secretary**

# CALIFORNIA ALL-PURPOSE ACKNOWLEDGMENT

STATE OF CALIFORNIA

County of San Diego }

On December 22, 2010 before me, J. E. Theodore, Notary Public,  
Date Here Insert Name and Title of the Officer

personally appeared Jennifer L. Cox  
Name(s) of Signer(s)

who proved to me on the basis of satisfactory evidence to be the person(s) whose name(s) is/~~is~~ subscribed to the within instrument and acknowledged to me that ~~he~~/she/~~they~~ executed the same in ~~his~~/her/~~their~~ authorized capacity(~~ies~~), and that by ~~his~~/her/~~their~~ signature(s) on the instrument the person(s), or the entity upon behalf of which the person(s) acted, executed the instrument.

I certify under PENALTY OF PERJURY under the laws of the State of California that the foregoing paragraph is true and correct.

Witness my hand and official seal.  
 Signature J. E. Theodore  
Signature of Notary Public

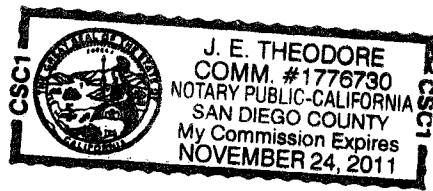

Place Notary Seal Above

## OPTIONAL

*Though the information below is not required by law, it may prove valuable to persons relying on the document and could prevent fraudulent removal and reattachment of this form to another document.*

### Description of Attached Document

Title or Type of Document: \_\_\_\_\_

Document Date: \_\_\_\_\_ Number of Pages: \_\_\_\_\_

Signer(s) Other Than Named Above: \_\_\_\_\_

### Capacity(ies) Claimed by Signer(s)

Signer's Name: \_\_\_\_\_

- Individual
- Corporate Officer — Title(s): \_\_\_\_\_
- Partner —  Limited  General
- Attorney in Fact
- Trustee
- Guardian or Conservator
- Other: \_\_\_\_\_

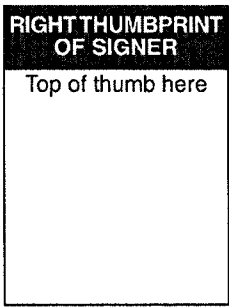

Signer Is Representing:  
 \_\_\_\_\_  
 \_\_\_\_\_  
 \_\_\_\_\_

Signer's Name: \_\_\_\_\_

- Individual
- Corporate Officer — Title(s): \_\_\_\_\_
- Partner —  Limited  General
- Attorney in Fact
- Trustee
- Guardian or Conservator
- Other: \_\_\_\_\_

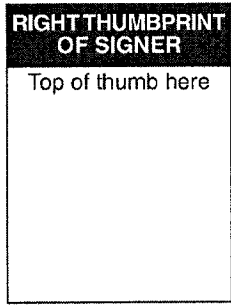

Signer Is Representing:  
 \_\_\_\_\_  
 \_\_\_\_\_  
 \_\_\_\_\_

**NONCOLLUSION AFFIDAVIT TO BE EXECUTED BY BIDDER AND  
SUBMITTED WITH BID**

State of California ) ss.  
County of Riverside )

Charles R. Gossage, being first duly sworn, deposes and says:

That he or she is Executive VP / Secretary of Stronghold Engineering, Inc. the party making the foregoing bid; that the bid is not made in the interest of, or on behalf of, any undisclosed person, partnership, company, association, organization, or corporation; that the bid is genuine and not collusive or sham; that the bidder has not directly or indirectly induced or solicited any other bidder to put in a false or sham bid, and has not directly or indirectly colluded, conspired, connived, or agreed with any bidder or anyone else to put in a sham bid, or that anyone shall refrain from bidding; that the bidder has not in any manner, directly or indirectly, sought by agreement, communication, or conference with anyone to fix the bid price of the bidder or any other bidder, or to fix any overhead, profit, or cost element of the bid price, or of that of any other bidder, or to secure any advantage against the public body awarding the contract of anyone interested in the proposed contract; that all statements contained in the bid are true; and, further, that the bidder has not, directly or indirectly, submitted his or her bid price or any breakdown thereof, or the contents thereof, or divulged information or data relative thereto, or paid, and will not pay, any fee to any corporation, partnership, company association, organization, bid depository, or to any member or agent thereof to effectuate a collusive or sham bid.

Signature 

Subscribed and sworn to before me this \_\_\_\_\_ day of \_\_\_\_\_, 2010.

\_\_\_\_\_  
Signature of officer administering oath

\* SEE ATTACHED JURAT



# Jurat

State of California

County of RIVERSIDE

Subscribed and sworn to (or affirmed) before me on this 12 day of JANUARY,

20 11 by CHARLES R. CROSSAGE

proved to me on the basis of satisfactory evidence to be the person(s) who appeared before me.

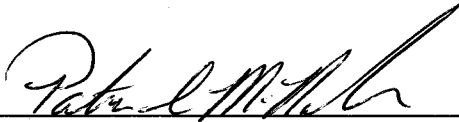

Signature

(Notary seal)

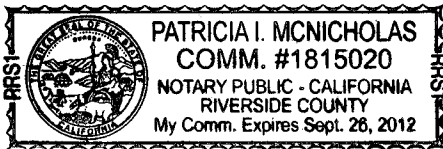

## OPTIONAL INFORMATION

### DESCRIPTION OF THE ATTACHED DOCUMENT

NON COLLUSION AFFIDAVIT  
(Title or description of attached document)

(Title or description of attached document continued)

Number of Pages 1 Document Date 12 Jan 11

CAC Parking Structure Solar System Lighting  
(Additional information)

### INSTRUCTIONS FOR COMPLETING THIS FORM

The wording of all Jurats completed in California after January 1, 2008 must be in the form as set forth within this Jurat. There are no exceptions. If a Jurat to be completed does not follow this form, the notary must correct the verbiage by using a jurat stamp containing the correct wording or attaching a separate jurat form such as this one which does contain proper wording. In addition, the notary must require an oath or affirmation from the document signer regarding the truthfulness of the contents of the document. The document must be signed AFTER the oath or affirmation. If the document was previously signed, it must be re-signed in front of the notary public during the jurat process.

- State and County information must be the State and County where the document signer(s) personally appeared before the notary public.
- Date of notarization must be the date that the signer(s) personally appeared which must also be the same date the jurat process is completed.
- Print the name(s) of document signer(s) who personally appear at the time of notarization.
- Signature of the notary public must match the signature on file with the office of the county clerk.
- The notary seal impression must be clear and photographically reproducible. Impression must not cover text or lines. If seal impression smudges, re-seal if a sufficient area permits, otherwise complete a different jurat form.
  - ❖ Additional information is not required but could help to ensure this jurat is not misused or attached to a different document.
  - ❖ Indicate title or type of attached document, number of pages and date.
- Securely attach this document to the signed document

**AWARD OF CONTRACT**

The undersigned fully understands that a Contract is formed upon the acceptance of this Proposal by the Owner and the undersigned further agrees that upon request he will promptly execute and deliver to Owner a written memorial of the Contract together with the required Payment and Performance Bonds and proof of insurance.

**BID GUARANTEE**

The enclosed certified or cashier's check or bidder's bond on approved form, made payable to the Owner in the amount of ten percent of the total bid submitted herewith, is hereby given as a guarantee that the bidder will execute and deliver the above mentioned written memorial and required bonds and insurance if awarded the contract, and in the event that the undersigned fails or refuses to execute and deliver said documents, such check or bond is to be charged with the costs of the damages experienced by the Owner as a result of such failure or refusal, including but not limited to publication costs, the difference in money between the amount of the bid of the said principal and the amount for which obligee may legally contract with another party to perform the said work if such amount be in excess of the former, building lease or rental costs, transportation costs and additional salary costs that result from the delay due to the principal's default on the awarded contract. In no event, however, shall the Surety's liability exceed the penal sum hereof.

Name of Bidder: Stronghold Engineering, Inc.

Type of Organization: Corporation

Signed By: \_\_\_\_\_

*Charles R. Gostage*

Title of Signer: Executive Vice President/Secretary

Affix Seal

Address of Bidder: 2000 Market Street

If

Riverside, CA 92501

Corporation

Telephone No.: (951) 684-9303

Contractor's License No.: 787490

Classification: A/B/C-10 Expiration Date: 11/30/2012

**LICENSURE STATEMENTS ARE MADE UNDER PENALTY OF PERJURY**

If bidder is a corporation, and signer is not President or Secretary, attach a certified copy of By-Laws or resolution authorizing execution. If bidder is a corporation, affix corporate seal. If signer is an agent, attach Power of Attorney. If bidder is not an individual, list names of other persons authorized to bind the organization.

Date: December 6, 2010  
Project: CAC Parking Structure Solar Project  
Project No.: FM0672000027  
Addendum: **NUMBER ONE**

I. INSTRUCTIONS:

- A. This supplement to the bid package is issued prior to the receipt of proposals. All changes covered in this supplement shall be included in the original quotation and the supplement will be considered one of the contract documents.
- B. Contractors, Manufacturers and/or Distributors shall confirm the receipt and consideration of this addendum prior to the submittal of their proposal by noting inclusion of addendum one on the Contractor's Proposal.

II. PURPOSE OF ADDENDUM:

- A. Electrical coordination clarifications.

III. CONTENT:

- 1. The P.V. module was changed from the Solon 230/15 to the SolarWolrd SunModule SW45 Mono. The new module will have a shorter lead time and is less expensive. It will also raise the power production. See sheet E1.0 for PV module specs.
- 2. The wiring of the P.V. modules was re arranged to provide balance between the three phases. See attached ESK1.0.

IV. ATTACHMENTS:

SEE FOLLOWING PAGE.

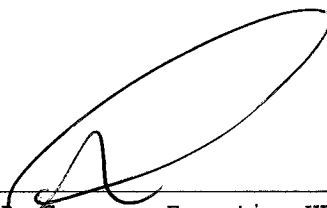
  
\_\_\_\_\_  
Charles R. Gossage, Executive VP/Secretary

12/6/2010  
Date

Date: December 30, 2010  
Project: CAC Parking Structure Solar Project  
Project No.: FM06720000027  
Addendum: **NUMBER TWO**

I. INSTRUCTIONS:

- A. This supplement to the bid package is issued prior to the receipt of proposals. All changes covered in this supplement shall be included in the original quotation and the supplement will be considered one of the contract documents.
- B. Contractors, Manufacturers and/or Distributors shall confirm the receipt and consideration of this addendum prior to the submittal of their proposal by noting inclusion of addendum two on the Contractor's Proposal.

II. PURPOSE OF ADDENDUM:

- A. To respond to all RFI's to issued construction documents dated 11-05-10 RFI's.

III. RFI'S AND ANSWERS:

1. RIS ELECTRICAL CONTRACTORS #3.

Question:

Per the note on S-2 and S-3, the concrete columns are to be tested. What percentage of the columns need to be tested and by what methods?

Answer:

All columns are to be tested. Use X-RAY, sonogram or other tests to establish: size of column, strength of concrete, size and location of reinforcement.

2. PACWEST CONSTRUCTION. 12/23/10 EMAIL.

Questions:

- a. Do you require good faith effort of DVBE for this project? If so, how many percent is the goal?
- b. Also, what are the documents that should be submitted with the bid?

Answers:

- a. This project does not have a specific requirement for DVBE participation.
- b. All forms are part and contained in the document: "SPECIFICATIONS AND CONTRACT DOCUMENTS FOR US DEPARTMENT OF ENERGY - SOLAR PROJECTS. CAC PARKING STRUCTURE SOLAR SYSTEM AND

Date: January 3, 2011  
Project: CAC Parking Structure Solar Project  
Project No.: FM0672000027  
Addendum: **NUMBER THREE**

I. INSTRUCTIONS:

- A. This supplement to the bid package is issued prior to the receipt of proposals. All changes covered in this supplement shall be included in the original quotation and the supplement will be considered one of the contract documents.
- B. Contractors, Manufacturers and/or Distributors shall confirm the receipt and consideration of this addendum prior to the submittal of their proposal by noting inclusion of addendum three on the Contractor's Proposal.

II. PURPOSE OF ADDENDUM:

- A. The purpose of this addendum is to provide all bidders with notice of the extension of the bid date.
- B. **The bid date is hereby extended to Wednesday, January 12, 2011, at 14:00 hrs. (2:00 PM). See attached Notice Inviting Bids document from the County of Riverside.**

III. CHANGES AND CLARIFICATIONS:

1. STRCUTURAL DETAIL #3 ON SHEET S-3.

The Hat Channel Runners material was changed to aluminum to prevent corrosion issues. The attachment from solar module to steel beam specification is as follows: UNIRAC Solar Mount-I Series Slider with Mid Clamp or equal.

-----END-----

  
\_\_\_\_\_  
Charles R. Gossage, Executive VP/Secretary

1/3/2011  
Date

**STRONGHOLD ENGINEERING INC.  
2000 MARKET STREET  
RIVERSIDE, CA 92501**

**County of Riverside Admir  
4080 Lemon Street  
Riverside, CA 92501**

**US DEPT OF ENERGY SOLAR PROJECTS CAC PARKING STRUCTURE  
SOLAR SYSTEM & LIGHTING UPGRADE, RIVERSIDE, CA  
PRICE PROPOSAL ENCLOSED  
12 JANUARY (WEDNESDAY), 2:00 P.M.**

**SEALD BID RECEIVED  
CLERK OF THE BOARD OF SUPERVISORS**

RECEIVED RIVERSIDE COUNTY  
CLERK/BOARD OF SUPERVISORS

2011 JAN 12 PM 1:54









**AWARD OF CONTRACT**

The undersigned fully understands that a Contract is formed upon the acceptance of this Proposal by the Owner and the undersigned further agrees that upon request he will promptly execute and deliver to Owner a written memorial of the Contract together with the required Payment and Performance Bonds and proof of insurance.

**BID GUARANTEE**

The enclosed certified or cashier's check or bidder's bond on approved form, made payable to the Owner in the amount of ten percent of the total bid submitted herewith, is hereby given as a guarantee that the bidder will execute and deliver the above mentioned written memorial and required bonds and insurance if awarded the contract, and in the event that the undersigned fails or refuses to execute and deliver said documents, such check or bond is to be charged with the costs of the damages experienced by the Owner as a result of such failure or refusal, including but not limited to publication costs, the difference in money between the amount of the bid of the said principal and the amount for which obligee may legally contract with another party to perform the said work if such amount be in excess of the former, building lease or rental costs, transportation costs and additional salary costs that result from the delay due to the principal's default on the awarded contract. In no event, however, shall the Surety's liability exceed the penal sum hereof.

Name of Bidder: R.I.S. Electrical Contractors, Inc.

Type of Organization: Corporation

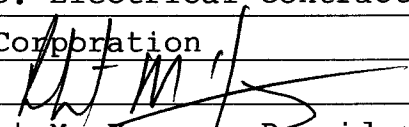
Signed By: 

Title of Signer: Robert M. Hayes - President

Address of Bidder: 7330 Sycamore Canyon Blvd St#1  
Riverside, CA92508

Affix Seal  
If  
Corporation

Telephone No.: 951-653-2611

Contractor's License No.: 712468

Classification: C-10, B Expiration Date: 9/30/11

**LICENSURE STATEMENTS ARE MADE UNDER PENALTY OF PERJURY**

If bidder is a corporation, and signer is not President or Secretary, attach a certified copy of By-Laws or resolution authorizing execution. If bidder is a corporation, affix corporate seal. If signer is an agent, attach Power of Attorney. If bidder is not an individual, list names of other persons authorized to bind the organization.

**NONCOLLUSION AFFIDAVIT TO BE EXECUTED BY BIDDER AND  
SUBMITTED WITH BID**

State of California ) ss.  
County of Riverside )

Robert M. Hayes, being first duly sworn, deposes and says:

That he or she is President of R.I.S. Electrical Contractors, Inc. the party making the foregoing bid; that the bid is not made in the interest of, or on behalf of, any undisclosed person, partnership, company, association, organization, or corporation; that the bid is genuine and not collusive or sham; that the bidder has not directly or indirectly induced or solicited any other bidder to put in a false or sham bid, and has not directly or indirectly colluded, conspired, connived, or agreed with any bidder or anyone else to put in a sham bid, or that anyone shall refrain from bidding; that the bidder has not in any manner, directly or indirectly, sought by agreement, communication, or conference with anyone to fix the bid price of the bidder or any other bidder, or to fix any overhead, profit, or cost element of the bid price, or of that of any other bidder, or to secure any advantage against the public body awarding the contract of anyone interested in the proposed contract; that all statements contained in the bid are true; and, further, that the bidder has not, directly or indirectly, submitted his or her bid price or any breakdown thereof, or the contents thereof, or divulged information or data relative thereto, or paid, and will not pay, any fee to any corporation, partnership, company, association, organization, bid depository, or to any member or agent thereof to effectuate a collusive or sham bid.

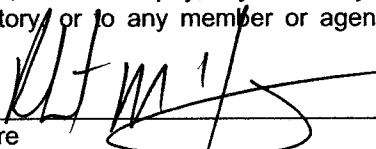
  
\_\_\_\_\_  
Signature

Subscribed and sworn to before me this 10 day of January 2011, 2010: -

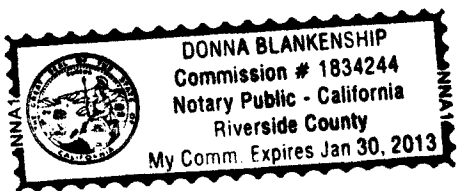

  
\_\_\_\_\_  
Signature of officer administering oath

DUKE BLANKENHORN  
Commission # 180414  
Notary Public - California  
Orange County  
My Commission Expires 09 30 2013

**Bid Bond**

KNOWN TO ALL MEN BY THESE PRESENTS, that we, the undersigned R.I.S. Electrical Contractors, Inc., as Principal; and Fidelity and Deposit Company of Maryland as Surety, are hereby held and firmly bound unto the County of Riverside, hereinafter called the "Owner", in the sum of Ten Percent of the Total Amount Bid----- Dollars (\$ 10%----- ) for the payment of such sum, well and truly to be made, do hereby jointly and severally bind ourselves, our heirs, executors, administrators, successors and assigns.

WHEREAS, the said Principal is herewith submitting its Proposal for the CAC Parking Structure Solar System & Lighting Upgrade

THE CONDITION OF THE ABOVE OBLIGATION IS SUCH, that if the aforesaid Principal shall be awarded the Contract upon said Proposal and shall, within the required number of days after the notice of such award, execute a written memorial of the awarded Contract and submit the required Labor and Material Payment and faithful Performance Bond and proof of insurance, then this obligation shall be null and void; and in the event that the Principal fails and/or refuses to execute and deliver said documents this Bond will be charged with the costs of the damages experienced by the Owner as a result of such refusal, including but not limited to, publication cost, the difference in money between the amount of the bid of the said Principal and the amount for which the obligee may legally contract with another party to perform the said work if such amount be in excess of the former; building lease or rental costs, transportation cost, and additional salary costs that result from the delay due to the Principal's default on the awarded Contract. In no event however, shall the Surety's liability exceed the penal sum hereof.

The Surety, for value received, hereby stipulates and agrees that the obligations of said Surety and its bond shall be in no way impaired or affected by any extension of the time within which the Owner may accept such bid; and said Surety does hereby waive notice of any such extension.

IN WITNESS WHEREOF, the above bounded parties have executed this instrument under their separate seals this 20th day of December, 2010, the name and corporate seal of each corporate party being hereto affixed and those present duly signed by its undersigned representative, pursuant to authority of its governing body.

R.I.S. Electrical Contractors, Inc.  
(Firm Name - Principal)

7330 Sycamore Canyon Blvd St#1 Riverside CA 92508  
(Business Address)

By [Signature]  
(Original Signature)  
Pres.  
(Title)

Affix Seal  
If  
Corporation

Fidelity and Deposit Company of Maryland  
(Corporation Name - Surety)

801 N. Brand Blvd., Penthouse Suite, Glendale, CA 91203  
(Business Address)

By [Signature]  
(Original Signature) Dwight Reilly,  
Attorney-In-Fact

Affix  
Corporate  
Seal

## ACKNOWLEDGMENT

State of California  
County of Orange )

On December 20th, 2010 before me, Allison Ritto, Notary Public  
(insert name and title of the officer)

personally appeared Dwight Reilly  
who proved to me on the basis of satisfactory evidence to be the person(s) whose name(s) is/are  
subscribed to the within instrument and acknowledged to me that he/~~she/they~~ executed the same in  
his/~~her/their~~ authorized capacity(ies), and that by his/~~her/their~~ signature(s) on the instrument the  
person(s), or the entity upon behalf of which the person(s) acted, executed the instrument.

I certify under PENALTY OF PERJURY under the laws of the State of California that the foregoing  
paragraph is true and correct.

WITNESS my hand and official seal.

Signature   
Allison Ritto

(Seal)

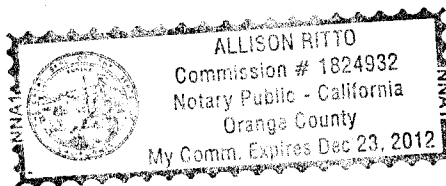

**Power of Attorney**  
**FIDELITY AND DEPOSIT COMPANY OF MARYLAND**

KNOW ALL MEN BY THESE PRESENTS: That the FIDELITY AND DEPOSIT COMPANY OF MARYLAND, a corporation of the State of Maryland, by DAVID S. HEWETT, Vice President, and ERIC D. BARNES, Assistant Secretary, in pursuance of authority granted by Article VI, Section 2, of the By-Laws of said Company, which are set forth on the reverse side hereof and are hereby certified to be in full force and effect on the date hereof, does hereby nominate, constitute and appoint **Dwight REILLY and Allison RITTO, both of Orange, California, EACH** its true and lawful agent and Attorney-in-Fact, to make, execute, seal and deliver, for, and on its behalf as surety, and as its act and deed: **any and all bonds and undertakings**, and the execution of such bonds or undertakings in pursuance of these presents, shall be as binding upon said Company, as fully and amply, to all intents and purposes, as if they had been duly executed and acknowledged by the regularly elected officers of the Company at its office in Baltimore, Md., in their own proper persons.

The said Assistant Secretary does hereby certify that the extract set forth on the reverse side hereof is a true copy of Article VI, Section 2, of the By-Laws of said Company, and is now in force.

IN WITNESS WHEREOF, the said Vice-President and Assistant Secretary have hereunto subscribed their names and affixed the Corporate Seal of the said FIDELITY AND DEPOSIT COMPANY OF MARYLAND, this 24th day of June, A.D. 2010.

ATTEST:

**FIDELITY AND DEPOSIT COMPANY OF MARYLAND**



*Eric D. Barnes*

*Eric D. Barnes*

*Assistant Secretary*

By:

*David S. Hewett*

*David S. Hewett*

*Vice President*

State of Maryland }  
City of Baltimore } ss:

On this 24th day of June, A.D. 2010, before the subscriber, a Notary Public of the State of Maryland, duly commissioned and qualified, came DAVID S. HEWETT, Vice President, and ERIC D. BARNES, Assistant Secretary of the FIDELITY AND DEPOSIT COMPANY OF MARYLAND, to me personally known to be the individuals and officers described in and who executed the preceding instrument, and they each acknowledged the execution of the same, and being by me duly sworn, severally and each for himself depose and saith, that they are the said officers of the Company aforesaid, and that the seal affixed to the preceding instrument is the Corporate Seal of said Company, and that the said Corporate Seal and their signatures as such officers were duly affixed and subscribed to the said instrument by the authority and direction of the said Corporation.

IN TESTIMONY WHEREOF, I have hereunto set my hand and affixed my Official Seal the day and year first above written.



*Constance A. Dunn*

*Constance A. Dunn*

*Notary Public*

My Commission Expires: July 14, 2011

**EXTRACT FROM BY-LAWS OF FIDELITY AND DEPOSIT COMPANY OF MARYLAND**

"Article VI, Section 2. The Chairman of the Board, or the President, or any Executive Vice-President, or any of the Senior Vice-Presidents or Vice-Presidents specially authorized so to do by the Board of Directors or by the Executive Committee, shall have power, by and with the concurrence of the Secretary or any one of the Assistant Secretaries, to appoint Resident Vice-Presidents, Assistant Vice-Presidents and Attorneys-in-Fact as the business of the Company may require, or to authorize any person or persons to execute on behalf of the Company any bonds, undertakings, recognizances, stipulations, policies, contracts, agreements, deeds, and releases and assignments of judgements, decrees, mortgages and instruments in the nature of mortgages,...and to affix the seal of the Company thereto."

**CERTIFICATE**

I, the undersigned, Assistant Secretary of the FIDELITY AND DEPOSIT COMPANY OF MARYLAND, do hereby certify that the foregoing Power of Attorney is still in full force and effect on the date of this certificate; and I do further certify that the Vice-President who executed the said Power of Attorney was one of the additional Vice-Presidents specially authorized by the Board of Directors to appoint any Attorney-in-Fact as provided in Article VI, Section 2, of the By-Laws of the FIDELITY AND DEPOSIT COMPANY OF MARYLAND.

This Power of Attorney and Certificate may be signed by facsimile under and by authority of the following resolution of the Board of Directors of the FIDELITY AND DEPOSIT COMPANY OF MARYLAND at a meeting duly called and held on the 10th day of May, 1990.

RESOLVED: "That the facsimile or mechanically reproduced seal of the company and facsimile or mechanically reproduced signature of any Vice-President, Secretary, or Assistant Secretary of the Company, whether made heretofore or hereafter, wherever appearing upon a certified copy of any power of attorney issued by the Company, shall be valid and binding upon the Company with the same force and effect as though manually affixed."

IN TESTIMONY WHEREOF, I have hereunto subscribed my name and affixed the corporate seal of the said Company,

this 20th day of December, 2010.

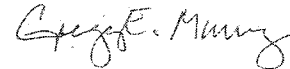

*Assistant Secretary*





**R.I.S. ELECTRICAL CONTRACTORS, INC.**  
7330 Sycamore Canyon Blvd., Suite 1  
Riverside, California 92508  
(951) 653-2611 • Fax (951) 653-5611

County of Riverside  
Attn: Clerk of the Board  
CAC Parking Structure  
Solar System & Lighting Upgrade  
Bid Date: 1/12/11      Bid Time: 2:00pm

**SEALED BID RECEIVED**  
**CLERK OF THE BOARD OF SUPERVISORS**

RECEIVED RIVERSIDE COUNTY  
CLERK / BOARD OF SUPERVISORS

JAN 12 PM 1:36

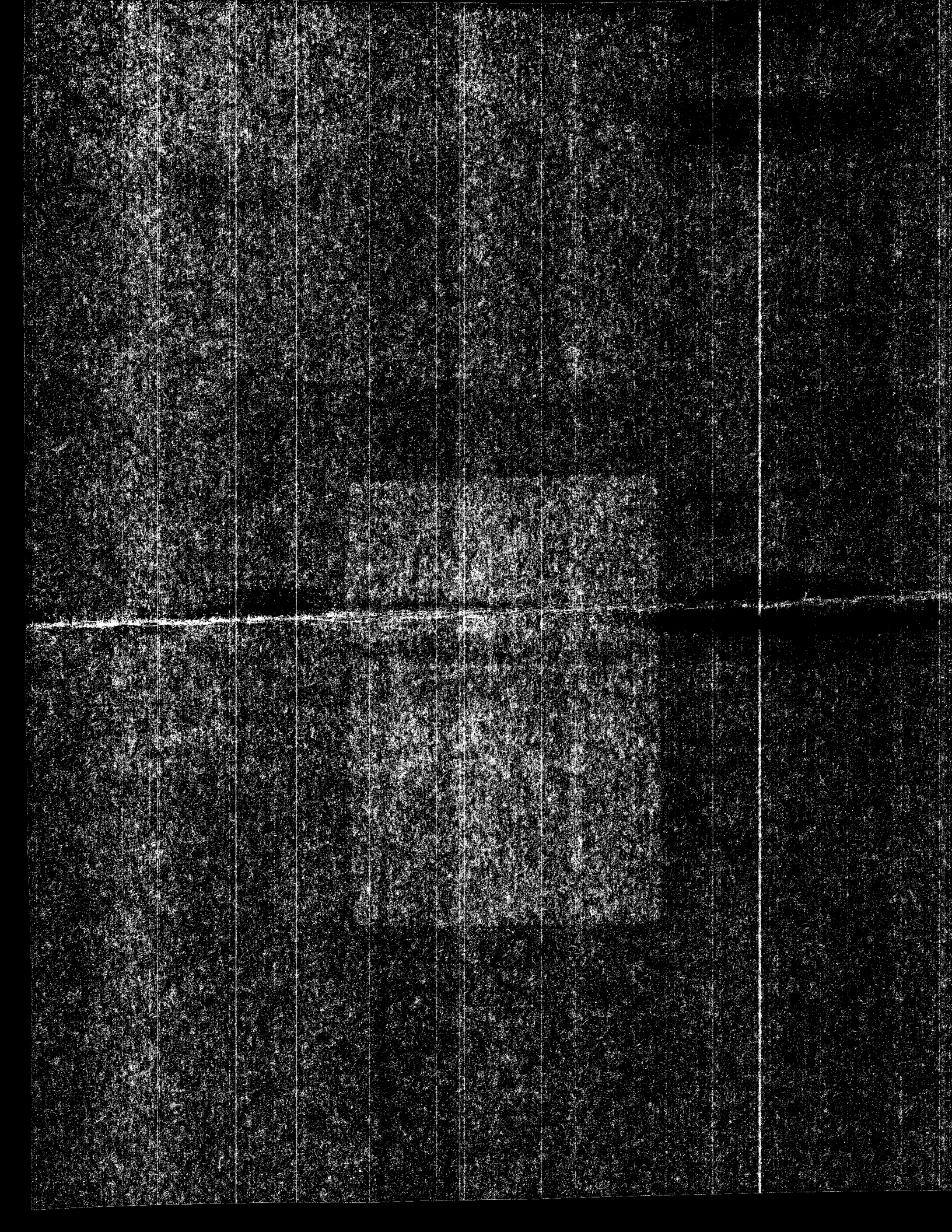

**CONTRACTOR'S PROPOSAL**

TO THE GOVERNING BOARD OF THE COUNTY OF RIVERSIDE:

Date: 1-12-11

Bidder: Dalke & Sons Construction, Inc.

The undersigned, having carefully examined the proposed site and the Plans and Specifications, the Notice Inviting Bids, the Instructions to Bidders, the Agreement Form, the Bond Forms, the General Conditions for the Construction of the CAC Parking Structure Solar System & Lighting Upgrade, hereby proposes and agrees to furnish all tools, equipment, services, apparatus, facilities, transportation, labor and materials necessary to complete the work in strict conformity with the Plans and Specifications, including all work specified in Addenda numbered and dated:

Addendum No. 1 Date 12/6/10  
Addendum No. 2 Date 12/30/10  
Addendum No. 3 Date 1/3/11

For the total Base Bid one million four 1,434,850 dollars (\$ 1,434,850 ), including all applicable taxes, permits, licenses, **AND Course of Construction Insurance.**

		(Add or Deduct state which)
Alternate 1	\$ <u>light fixtures</u> <u>0</u>	<u>add</u>
Alternate 2	\$ <u>maintenance</u> <u>0</u>	
Alternate 3	\$ <u>alternate markers</u> <u>0</u>	
Alternate 4	\$ _____	

And,  
Cost of Contractor's Course of Construction Insurance \_\_\_\_\_ dollars (\$ 3,400 )  
and deductible \$ 10,000

Bids must be submitted on all items. Failure to bid on all items may result in the bid being rejected as non-responsive. The basis for award will be the qualified bidder with the lowest total of the Base Bid WITH COURSE OF CONSTRUCTION INSURANCE and all alternates. Alternates may be awarded in any order after determination of the lowest responsible and responsive bidder.





**AWARD OF CONTRACT**

The undersigned fully understands that a Contract is formed upon the acceptance of this Proposal by the Owner and the undersigned further agrees that upon request he will promptly execute and deliver to Owner a written memorial of the Contract together with the required Payment and Performance Bonds and proof of insurance.

**BID GUARANTEE**

The enclosed certified or cashier's check or bidder's bond on approved form, made payable to the Owner in the amount of ten percent of the total bid submitted herewith, is hereby given as a guarantee that the bidder will execute and deliver the above mentioned written memorial and required bonds and insurance if awarded the contract, and in the event that the undersigned fails or refuses to execute and deliver said documents, such check or bond is to be charged with the costs of the damages experienced by the Owner as a result of such failure or refusal, including but not limited to publication costs, the difference in money between the amount of the bid of the said principal and the amount for which obligee may legally contract with another party to perform the said work if such amount be in excess of the former, building lease or rental costs, transportation costs and additional salary costs that result from the delay due to the principal's default on the awarded contract. In no event, however, shall the Surety's liability exceed the penal sum hereof.

Name of Bidder: Dalke & Sons Construction, Inc.

Type of Organization: Corporation

Signed By: 

Title of Signer: Vice President

Affix Seal  
If  
Corporation

Address of Bidder: 4585 Allstate Drive  
Riverside, CA 92501

Telephone No.: 951-274-9880

Contractor's License No.: 612500

Classification: B, C-10 Expiration Date: 2-28-11

**LICENSURE STATEMENTS ARE MADE UNDER PENALTY OF PERJURY**

If bidder is a corporation, and signer is not President or Secretary, attach a certified copy of By-Laws or resolution authorizing execution. If bidder is a corporation, affix corporate seal. If signer is an agent, attach Power of Attorney. If bidder is not an individual, list names of other persons authorized to bind the organization.

**NONCOLLUSION AFFIDAVIT TO BE EXECUTED BY BIDDER AND  
SUBMITTED WITH BID**

State of California ) ss.  
County of Riverside )

Barry Dalke, being first duly sworn, deposes and says:

That ~~he~~ <sup>she</sup> is Vice President of Dalke & Sons Construction, Inc. the party making the foregoing bid; that the bid is not made in the interest of, or on behalf of, any undisclosed person, partnership, company, association, organization, or corporation; that the bid is genuine and not collusive or sham; that the bidder has not directly or indirectly induced or solicited any other bidder to put in a false or sham bid, and has not directly or indirectly colluded, conspired, connived, or agreed with any bidder or anyone else to put in a sham bid, or that anyone shall refrain from bidding; that the bidder has not in any manner, directly or indirectly, sought by agreement, communication, or conference with anyone to fix the bid price of the bidder or any other bidder, or to fix any overhead, profit, or cost element of the bid price, or of that of any other bidder, or to secure any advantage against the public body awarding the contract of anyone interested in the proposed contract; that all statements contained in the bid are true; and, further, that the bidder has not, directly or indirectly, submitted his or her bid price or any breakdown thereof, or the contents thereof, or divulged information or data relative thereto, or paid, and will not pay, any fee to any corporation, partnership, company association, organization, bid depository, or to any member or agent thereof to effectuate a collusive or sham bid.

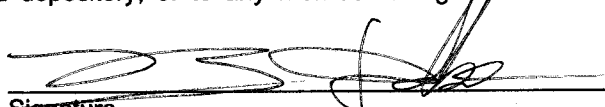
  
Signature

Subscribed and sworn to before me this 11th day of January, 2010.11

SEE ATTACH CERTIFICATE  
Signature of officer administering oath

**CALIFORNIA ALL-PURPOSE ACKNOWLEDGMENT**

State of California

County of Riverside

On January 11, 2011 before me, Elvia Villeda, Notary Public  
Date Here Insert Name and Title of the Officer

personally appeared Barry Dalke  
Name(s) of Signer(s)

who proved to me on the basis of satisfactory evidence to be the person(s) whose name(s) is/are subscribed to the within instrument and acknowledged to me that he/she/they executed the same in his/her/their authorized capacity(ies); and that by his/her/their signature(s) on the instrument the person(s); or the entity upon behalf of which the person(s) acted, executed the instrument.

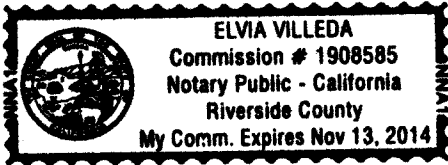

I certify under PENALTY OF PERJURY under the laws of the State of California that the foregoing paragraph is true and correct.

WITNESS my hand and official seal.

Signature: [Signature]  
Signature of Notary Public

Place Notary Seal Above

**OPTIONAL**

*Though the information below is not required by law, it may prove valuable to persons relying on the document and could prevent fraudulent removal and reattachment of this form to another document.*

**Description of Attached Document**

Title or Type of Document: Noncollusion Affidavit

Document Date: \_\_\_\_\_ Number of Pages: \_\_\_\_\_

Signer(s) Other Than Named Above: \_\_\_\_\_

**Capacity(ies) Claimed by Signer(s)**

Signer's Name: \_\_\_\_\_ Signer's Name: \_\_\_\_\_

Corporate Officer — Title(s): \_\_\_\_\_  Corporate Officer — Title(s): \_\_\_\_\_

Individual  Individual

Partner —  Limited  General  Partner —  Limited  General

Attorney in Fact  Attorney in Fact

Trustee  Trustee

Guardian or Conservator  Guardian or Conservator

Other: \_\_\_\_\_  Other: \_\_\_\_\_

Signer Is Representing: \_\_\_\_\_ Signer Is Representing: \_\_\_\_\_

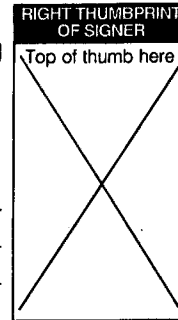
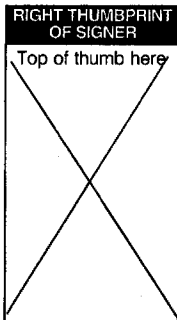



RECEIVED  
GOVERNMENT & COMMUNITY DEVELOPMENT  
DIVISION  
MAY 13 1984





# Power of Attorney

## WESTCHESTER FIRE INSURANCE COMPANY

Know all men by these presents: That WESTCHESTER FIRE INSURANCE COMPANY, a corporation of the State of New York, having its principal office in the City of Atlanta, Georgia pursuant to the following Resolution, adopted by the Board of Directors of the said Company on December 11, 2006, to wit:

"RESOLVED, that the following authorizations relate to the execution, for and on behalf of the Company, of bonds, undertakings, recognizances, contracts and other written commitments of the Company entered into the ordinary course of business (each a "Written Commitment"):

- (1) Each of the Chairman, the President and the Vice Presidents of the Company is hereby authorized to execute any Written Commitment for and on behalf of the Company, under the seal of the Company or otherwise.
- (2) Each duly appointed attorney-in-fact of the Company is hereby authorized to execute any Written Commitment for and on behalf of the Company, under the seal of the Company or otherwise, to the extent that such action is authorized by the grant of powers provided for in such persons written appointment as such attorney-in-fact.
- (3) Each of the Chairman, the President and the Vice Presidents of the Company is hereby authorized, for and on behalf of the Company, to appoint in writing any person the attorney-in-fact of the Company with full power and authority to execute, for and on behalf of the Company, under the seal of the Company or otherwise, such Written Commitments of the Company as may be specified in such written appointment, which specification may be by general type or class of Written Commitments or by specification of one or more particular Written Commitments.
- (4) Each of the Chairman, the President and Vice Presidents of the Company is hereby authorized, for and on behalf of the Company, to delegate in writing any other officer of the Company the authority to execute, for and on behalf of the Company, under the Company's seal or otherwise, such Written Commitments of the Company as are specified in such written delegation, which specification may be by general type or class of Written Commitments or by specification of one or more particular Written Commitments.
- (5) The signature of any officer or other person executing any Written Commitment or appointment or delegation pursuant to this Resolution, and the seal of the Company, may be affixed by facsimile on such Written Commitment or written appointment or delegation.

FURTHER RESOLVED, that the foregoing Resolution shall not be deemed to be an exclusive statement of the powers and authority of officers, employees and other persons to act for and on behalf of the Company, and such Resolution shall not limit or otherwise affect the exercise of any such power or authority otherwise validly granted or vested.

FURTHER RESOLVED, that the Resolution of the Board of Directors of the Company adopted at the meeting held on November 8, 1999 relating to the authorization of certain persons to execute, for and on behalf of the Company, Written Commitments and appointments and delegations, is hereby rescinded.

Does hereby nominate, constitute and appoint John A Ruiz, Karen A Eby, Melody L Spaur, Timothy C Baker, all of the City of TEMECULA, California, each individually if there be more than one named, its true and lawful attorney-in-fact, to make, execute, seal and deliver on its behalf, and as its act and deed any and all bonds, undertakings, recognizances, contracts and other writings in the nature thereof in penalties not exceeding Three million dollars & zero cents (\$3,000,000.00) and the execution of such writings in pursuance of these presents shall be as binding upon said Company, as fully and amply as if they had been duly executed and acknowledged by the regularly elected officers of the Company at its principal office.

IN WITNESS WHEREOF, the said Stephen M. Haney, Vice-President, has hereunto subscribed his name and affixed the Corporate seal of the said WESTCHESTER FIRE INSURANCE COMPANY this 29 day of May 2009.

WESTCHESTER FIRE INSURANCE COMPANY



*Stephen M. Haney*  
Stephen M. Haney, Vice President

COMMONWEALTH OF PENNSYLVANIA  
COUNTY OF PHILADELPHIA ss.

On this 29 day of May, AD. 2009 before me, a Notary Public of the Commonwealth of Pennsylvania in and for the County of Philadelphia came Stephen M. Haney, Vice-President of the WESTCHESTER FIRE INSURANCE COMPANY to me personally known to be the individual and officer who executed the preceding instrument, and he acknowledged that he executed the same, and that the seal affixed to the preceding instrument is the corporate seal of said Company; that the said corporate seal and his signature were duly affixed by the authority and direction of the said corporation, and that Resolution, adopted by the Board of Directors of said Company, referred to in the preceding instrument, is now in force.

IN TESTIMONY WHEREOF, I have hereunto set my hand and affixed my official seal at the City of Philadelphia the day and year first above written.

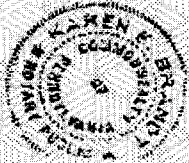

COMMONWEALTH OF PENNSYLVANIA  
NOTARIAL SEAL  
KAREN E. BRANDT Notary Public  
City of Philadelphia, Phila. County  
My Commission Expires September 26, 2010

*Karen E. Brandt*  
Notary Public

I, the undersigned Assistant Secretary of the WESTCHESTER FIRE INSURANCE COMPANY, do hereby certify that the original POWER OF ATTORNEY, of which the foregoing is a substantially true and correct copy, is in full force and effect.

In witness whereof, I have hereunto subscribed my name as Assistant Secretary, and affixed the corporate seal of the Corporation, this 23 day of December, 2010



*William L. Kelly*  
William L. Kelly, Assistant Secretary

THIS POWER OF ATTORNEY MAY NOT BE USED TO EXECUTE ANY BOND WITH AN INCEPTION DATE AFTER May 29, 2011.

**CALIFORNIA ALL-PURPOSE ACKNOWLEDGEMENT**

State of California }  
County of Riverside } SS.

On 23 December 2010 Before Me

K. A. EBY, a Notary Public  
Name of Notary Public

Personally Appeared

Melody L. Spaur  
Name(s) of Signer(s)

Proved to me on the basis of satisfactory evidence

To be the person(s) whose name(s) is / are subscribed to the within instrument and acknowledged to me that he / she / they executed the same in his / her / their authorized capacity(ies) and that by his / her / their signature(s) on the instrument the person(s), or the entity upon behalf of which the person(s) acted, executed the instrument.

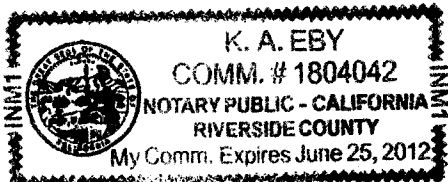

I certify under PENALTY OF PERJURY under the laws of the State of California that the foregoing paragraph is true and correct.

WITNESS my hand and official seal.

[Signature]  
Signature of Notary Public

Notary Stamp

License Number Expires

**OPTIONAL**

Though the information below is not required by law, it may prove valuable to persons relying on the document and could prevent fraudulent removal and reattachment of this form to another document.

**Description of Attached Document**

Title our Type of Document: \_\_\_\_\_

Document Date: \_\_\_\_\_ Number of Pages \_\_\_\_\_

Signer(s) Other Than Named Above: \_\_\_\_\_

**Capacity(ies) Claimed by Signer(s)**

Signers Name: \_\_\_\_\_

- Individual:
- Corporate Officer - Title(s):
- Partner -  Limited  General
- Attorney-in-fact
- Trustee
- Guardian or Conservator
- Other: \_\_\_\_\_

Signer is Representing \_\_\_\_\_

Right Thumb Print  
of Signer 1

Right Thumb Print  
of Signer 2

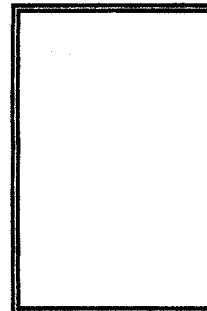
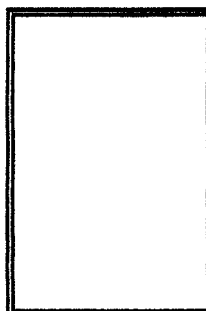

**CONTRACTOR'S CERTIFICATE  
REGARDING WORKERS' COMPENSATION**

Labor Code Section 3700

Every employer, except the State and all political subdivisions or institutions thereof, shall secure the payment of compensation in one or more of the following ways:

- (a) By being insured against liability to pay compensation in one or more insurers duly authorized to write compensation insurance in this State.
  
- (b) By securing from the Director of Industrial Relations, a Certificate of Consent to Self-Insure, which may be given upon furnishing proof satisfactory to the Director of Industrial Relations of ability to self-insure and to pay any compensation that may become due to his employees

I am aware of the provisions of Section 3700 of the Labor Code which requires every employer to be insured against liability for Workers' Compensation or to undertake self-insurance in accordance with the provisions of that Code, and I will comply with such provisions before commencing the performance of this Contract.

Dalke & Sons Construction, Inc.

Principal



Principal

Barry Dalke, Vice President

Title

(In accordance with Article 5 [commencing at Section 1860], Chapter, Part 7, Division 2 of the Labor Code, the above Certificate must be signed and filed with the Owner prior to performing any work under this Contract.)



**DALKE & SONS CONSTRUCTION, INC.**

Corporation Certificate

State of California )  
 )  
County of Riverside )

I HEREBY CERTIFY that during a meeting of the Board of Directors of **Dalke & Sons Construction, Inc.** a corporation existing under the Laws of the State of California, held on June 23, 1994, the following resolution was duly passed and adopted:

“Resolved, that **Barry Dalke, Troy Dalke, Todd Dalke, Calvin Dalke Jr.** as Vice President of the corporation, be and is hereby authorized to execute all Bid and Contract documents for this corporation and that his execution thereof and with the Corporate Seal affixed, shall be the official act and deed of this Corporation.”

I further certify that said resolution is now in full force and effect.

IN WITNESS WHEREOF, I have hereunto set my hand and affixed the official seal of the corporation this 23rd , day of June, 1994.

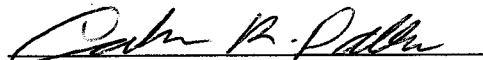
  
Calvin R. Dalke, President

  
Carol A. Dalke, Secretary

**SEALED BID RECEIVED**  
**CLERK OF THE BOARD OF SUPERVISORS**

RECEIVED RIVERSIDE COUNTY  
CLERK / BOARD OF SUPERVISORS

2011 JAN 12 PM 1:59

Bid Proposal For:  
**County of Riverside**  
4080 Lemon St.  
Riverside, CA 92501

**CAC Parking Structure Solar System &**  
**Lighting Upgrade**

Bid Date: January 12, 2011

Bid Time: 2:00 p.m.

**Sealed Bid Enclosed**

**\*DONT OPEN W/REGULAR MAIL\***

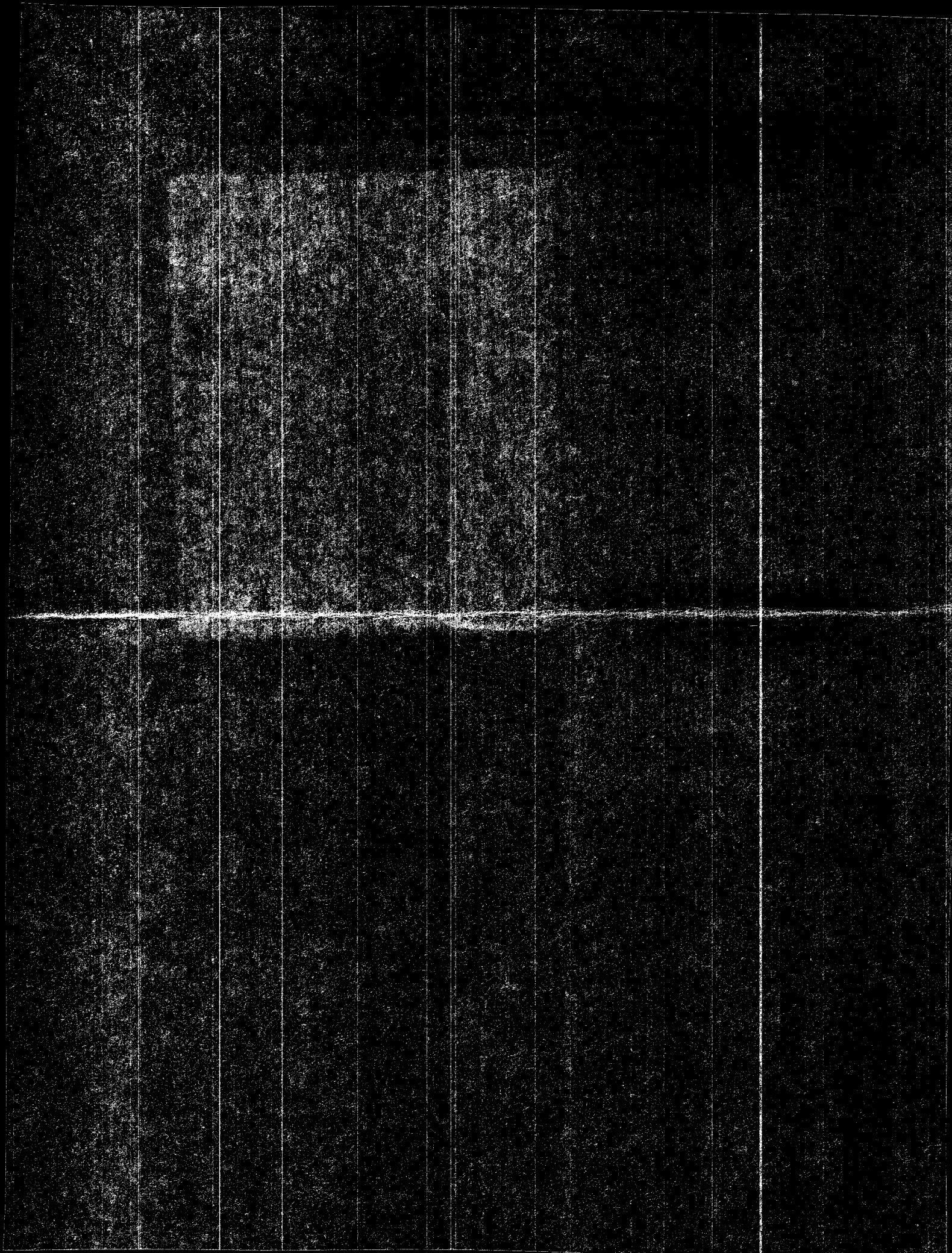



**CONTRACTOR'S PROPOSAL**

TO THE GOVERNING BOARD OF THE COUNTY OF RIVERSIDE:

Date: 1/5/11

Bidder: Fast-Track Construction Corporation

The undersigned, having carefully examined the proposed site and the Plans and Specifications, the Notice Inviting Bids, the Instructions to Bidders, the Agreement Form, the Bond Forms, the General Conditions for the Construction of the CAC Parking Structure Solar System & Lighting Upgrade, hereby proposes and agrees to furnish all tools, equipment, services, apparatus, facilities, transportation, labor and materials necessary to complete the work in strict conformity with the Plans and Specifications, including all work specified in Addenda numbered and dated:

Addendum No. 1 Date 12/6/10  
Addendum No. 2 Date 12/30/10  
Addendum No. 3 Date 1/3/11

For the total Base Bid one million four hundred + fifty five thousand ~~95~~ dollars (\$ 1,455,000.00 ~~95~~ 00 F.C. including all applicable taxes, permits, licenses, **AND Course of Construction Insurance.**

Alternate 1 (deduct)	\$ <u>(8,000)</u>	(Add or Deduct state which)	<u>LSI light fixture</u>
Alternate 2 (ADD)	<u>C.O. \$46,000.00 C.O.</u>		<u>4 yr Maintenance (3 visits)</u>
Alternate 3 (deduct)	\$ <u>(20,000.00)</u>		<u>Alternate solar panels (sharp)</u>
Alternate 4	\$ _____		_____

And,  
Cost of Contractor's Course of Construction Insurance Two thousand \$/m dollars (\$ 2,000.00 ) and deductible \$ 2,000.00

Bids must be submitted on all items. Failure to bid on all items may result in the bid being rejected as non-responsive. The basis for award will be the qualified bidder with the lowest total of the Base Bid WITH COURSE OF CONSTRUCTION INSURANCE and all alternates. Alternates may be awarded in any order after determination of the lowest responsible and responsive bidder.

\* SEE ATTACHED WORK SCHEDULE AS REQUIRES PER ADDENDUM #2 ITEM #10 \*

CAC Parking Structure Preliminary Project/Duration Schedule

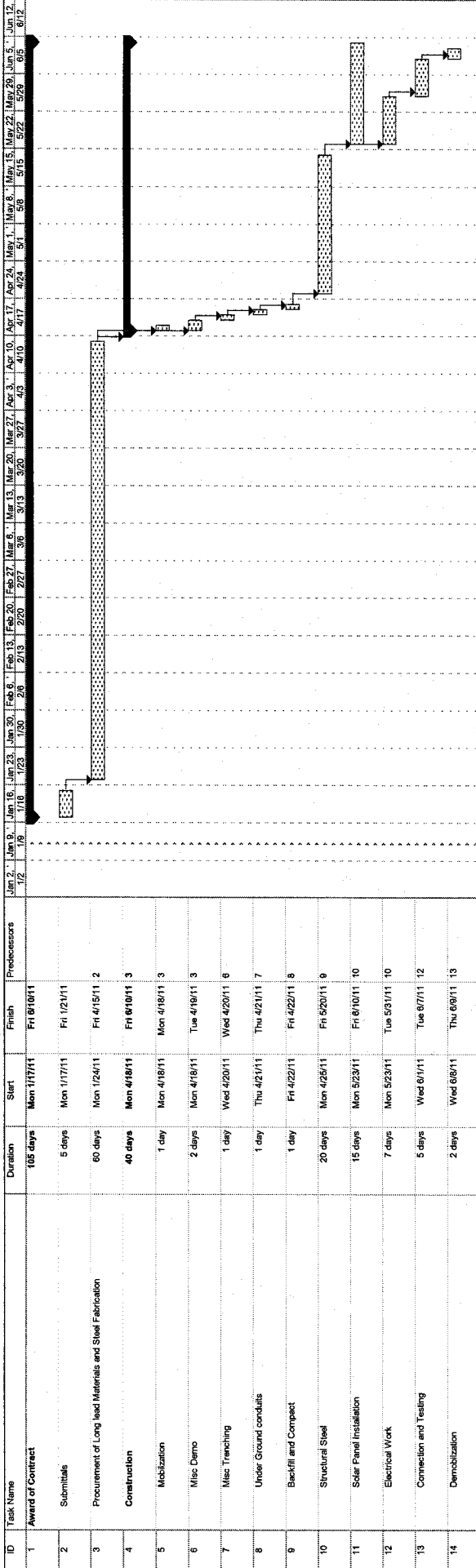

Project: CAC Solar Project  
 Date: Wed 1/12/11

Task Split

Progress Milestone

Summary Project Summary

External Tasks External Milestone

Deadline

Fast-Track Construction







**AWARD OF CONTRACT**

The undersigned fully understands that a Contract is formed upon the acceptance of this Proposal by the Owner and the undersigned further agrees that upon request he will promptly execute and deliver to Owner a written memorial of the Contract together with the required Payment and Performance Bonds and proof of insurance.

**BID GUARANTEE**

The enclosed certified or cashier's check or bidder's bond on approved form, made payable to the Owner in the amount of ten percent of the total bid submitted herewith, is hereby given as a guarantee that the bidder will execute and deliver the above mentioned written memorial and required bonds and insurance if awarded the contract, and in the event that the undersigned fails or refuses to execute and deliver said documents, such check or bond is to be charged with the costs of the damages experienced by the Owner as a result of such failure or refusal, including but not limited to publication costs, the difference in money between the amount of the bid of the said principal and the amount for which obligee may legally contract with another party to perform the said work if such amount be in excess of the former, building lease or rental costs, transportation costs and additional salary costs that result from the delay due to the principal's default on the awarded contract. In no event, however, shall the Surety's liability exceed the penal sum hereof.

Name of Bidder: Fast-Track Construction Corporation  
Type of Organization: Corporation  
Signed By: Richard Oja  
Title of Signer: President Affix Seal  
Address of Bidder: 5857 Uplander Way If  
Culver City, CA 90230 Corporation  
Telephone No.: (310) 215-3099  
Contractor's License No.: 674880  
Classification: B Expiration Date: 7/31/11

LICENSURE STATEMENTS ARE MADE UNDER PENALTY OF PERJURY

If bidder is a corporation, and signer is not President or Secretary, attach a certified copy of By-Laws or resolution authorizing execution. If bidder is a corporation, affix corporate seal. If signer is an agent, attach Power of Attorney. If bidder is not an individual, list names of other persons authorized to bind the organization.

**NONCOLLUSION AFFIDAVIT TO BE EXECUTED BY BIDDER AND  
SUBMITTED WITH BID**

State of California ) ss.  
County of Riverside )

Richard Tyler

, being first duly sworn, deposes and says:

That he or she is President of Fast-Track Construction Corp.  
the party making the foregoing bid; that the bid is not made in the interest of, or on behalf of, any undisclosed person, partnership, company, association, organization, or corporation; that the bid is genuine and not collusive or sham; that the bidder has not directly or indirectly induced or solicited any other bidder to put in a false or sham bid, and has not directly or indirectly colluded, conspired, connived, or agreed with any bidder or anyone else to put in a sham bid, or that anyone shall refrain from bidding; that the bidder has not in any manner, directly or indirectly, sought by agreement, communication, or conference with anyone to fix the bid price of the bidder or any other bidder, or to fix any overhead, profit, or cost element of the bid price, or of that of any other bidder, or to secure any advantage against the public body awarding the contract of anyone interested in the proposed contract; that all statements contained in the bid are true; and, further, that the bidder has not, directly or indirectly, submitted his or her bid price or any breakdown thereof, or the contents thereof, or divulged information or data relative thereto, or paid, and will not pay, any fee to any corporation, partnership, company association, organization, bid depository, or to any member or agent thereof to effectuate a collusive or sham bid.

[Signature]  
Signature

Subscribed and sworn to before me this 5<sup>th</sup> day of January, 2011.

[Signature]  
Signature of officer administering oath

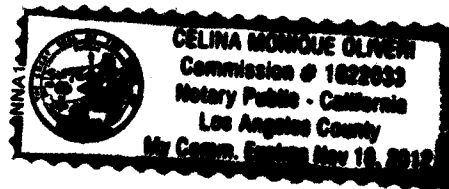

CELINA MONROE OLIVERI  
Commission # 182823  
Notary Public - California  
Los Angeles County  
My Comm. Expires Nov 18, 2018



**Bid Bond**

KNOWN TO ALL MEN BY THESE PRESENTS, that we, the undersigned Fast Track Construction Corporation, as Principal; and Arch Insurance Company, as Surety, are hereby held and firmly bound unto the County of Riverside, hereinafter called the "Owner", in the sum of \*\*\*\*\* Dollars (\$ 160,000.00) for the payment of such sum, well and truly to be made, do hereby jointly and severally bind ourselves, our heirs, executors, administrators, successors and assigns. \*10% percent of bid amount not to exceed One hundred sixty thousand and 00/100\*Dollars

WHEREAS, the said Principal is herewith submitting its Proposal for the #FM06720000027-CAC Parking Structure Solar System & Lighting Upgrade

THE CONDITION OF THE ABOVE OBLIGATION IS SUCH, that if the aforesaid Principal shall be awarded the Contract upon said Proposal and shall, within the required number of days after the notice of such award, execute a written memorial of the awarded Contract and submit the required Labor and Material Payment and faithful Performance Bond and proof of insurance, then this obligation shall be null and void; and in the event that the Principal fails and/or refuses to execute and deliver said documents this Bond will be charged with the costs of the damages experienced by the Owner as a result of such refusal, including but not limited to, publication cost, the difference in money between the amount of the bid of the said Principal and the amount for which the obligee may legally contract with another party to perform the said work if such amount be in excess of the former; building lease or rental costs, transportation cost, and additional salary costs that result from the delay due to the Principal's default on the awarded Contract. In no event however, shall the Surety's liability exceed the penal sum hereof.

The Surety, for value received, hereby stipulates and agrees that the obligations of said Surety and its bond shall be in no way impaired or affected by any extension of the time within which the Owner may accept such bid; and said Surety does hereby waive notice of any such extension.

IN WITNESS WHEREOF, the above bounded parties have executed this instrument under their separate seals this 4th day of January, 2011~~2010~~, the name and corporate seal of each corporate party being hereto affixed and those present duly signed by its undersigned representative, pursuant to authority of its governing body.

Fast Track Construction Corporation

(Firm Name - Principal)  
5857 Uplander Way  
Culver City, CA 90230  
(Business Address)

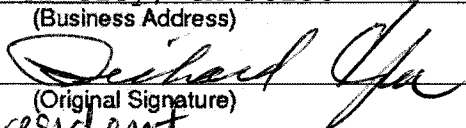
By   
(Original Signature)  
President  
(Title)

Affix Seal  
If  
Corporation

Arch Insurance Company  
(Corporation Name - Surety)  
135 North Los Robles Avenue, Suite 825  
Pasadena, CA 91101  
(Business Address)

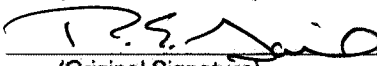
By   
(Original Signature)  
Raymond E. Gail, Attorney in Fact

Affix  
Corporate  
Seal



**CALIFORNIA ALL-PURPOSE ACKNOWLEDGMENT**

State of California

County of San Bernardino



On JAN 04 2011 before me, Stacia C. Baker, Notary Public  
Date Here Insert Name and Title of the Officer

personally appeared Raymond E. Gail  
Name(s) of Signer(s)

N/A

who proved to me on the basis of satisfactory evidence to be the person(s) whose name(s) is/are subscribed to the within instrument and acknowledged to me that he/~~she/they~~ executed the same in his/~~her/their~~ authorized capacity(ies), and that by his/~~her/their~~ signature(s) on the instrument the person(s), or the entity upon behalf of which the person(s) acted, executed the instrument.

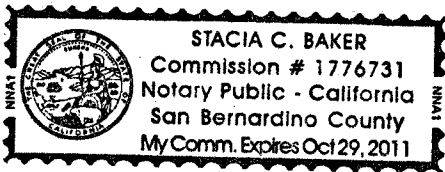

I certify under PENALTY OF PERJURY under the laws of the State of California that the foregoing paragraph is true and correct.

WITNESS my hand and official seal.

Signature Stacia C. Baker  
Signature of Notary Public

Place Notary Seal Above

**OPTIONAL**

*Though the information below is not required by law, it may prove valuable to persons relying on the document and could prevent fraudulent removal and reattachment of this form to another document.*

**Description of Attached Document**

Title or Type of Document: \_\_\_\_\_

Document Date: \_\_\_\_\_ Number of Pages: \_\_\_\_\_

Signer(s) Other Than Named Above: \_\_\_\_\_

**Capacity(ies) Claimed by Signer(s)**

Signer's Name: \_\_\_\_\_

- Individual
- Corporate Officer — Title(s): \_\_\_\_\_
- Partner —  Limited  General
- Attorney in Fact
- Trustee
- Guardian or Conservator
- Other: \_\_\_\_\_

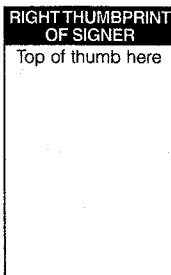

Signer Is Representing: \_\_\_\_\_

Signer's Name: \_\_\_\_\_

- Individual
- Corporate Officer — Title(s): \_\_\_\_\_
- Partner —  Limited  General
- Attorney in Fact
- Trustee
- Guardian or Conservator
- Other: \_\_\_\_\_

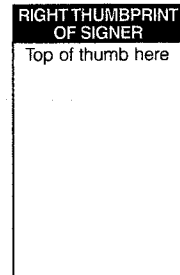

Signer Is Representing: \_\_\_\_\_

## POWER OF ATTORNEY

Know All Men By These Presents:

That the Arch Insurance Company, a corporation organized and existing under the laws of the State of Missouri, having its principal office in Kansas City, Missouri (hereinafter referred to as the "Company") does hereby appoint

Raymond E. Gail and William J. Shupper of Rancho Cucamonga, CA (EACH)

its true and lawful Attorney(s)-in-Fact, to make, execute, seal, and deliver from the date of issuance of this power for and on its behalf as surety, and as its act and deed:

Any and all bonds and undertakings

**EXCEPTION:** NO AUTHORITY is granted to make, execute, seal and deliver bonds or undertakings that guarantee the payment or collection of any promissory note, check, draft or letter of credit.

This authority does not permit the same obligation to be split into two or more bonds in order to bring each such bond within the dollar limit of authority as set forth herein.

The Company may revoke this appointment at any time.

The execution of such bonds and undertakings in pursuance of these presents shall be as binding upon the said Company as fully and amply to all intents and purposes, as if the same had been duly executed and acknowledged by its regularly elected officers at its principal office in Kansas City, Missouri.

This Power of Attorney is executed by authority of resolutions adopted by unanimous consent of the Board of Directors of the Company on March 3, 2003, true and accurate copies of which are hereinafter set forth and are hereby certified to by the undersigned Secretary as being in full force and effect:

"VOTED, That the Chairman of the Board, the President, or any Vice President, or their appointees designated in writing and filed with the Secretary, or the Secretary shall have the power and authority to appoint agents and attorneys-in-fact, and to authorize them to execute on behalf of the Company, and attach the seal of the Company thereto, bonds and undertakings, recognizances, contracts of indemnity and other writings, obligatory in the nature thereof, and any such officers of the Company may appoint agents for acceptance of process."

This Power of Attorney is signed, sealed and certified by facsimile under and by authority of the following resolution adopted by the unanimous consent of the Board of Directors of the Company on March 3, 2003:

VOTED, That the signature of the Chairman of the Board, the President, or any Vice President, or their appointees designated in writing and filed with the Secretary, and the signature of the Secretary, the seal of the Company, and certifications by the Secretary, may be affixed by facsimile on any power of attorney or bond executed pursuant to the resolution adopted by the Board of Directors on March 3, 2003, and any such power so executed, sealed and certified with respect to any bond or undertaking to which it is attached, shall continue to be valid and binding upon the Company.

In Testimony Whereof, the Company has caused this instrument to be signed and its corporate seal to be affixed by their authorized officers, this 1st day of May, 2008.

Arch Insurance Company

Attested and Certified



*Martin J. Nilsen*  
Martin J. Nilsen, Secretary

*J. Michael Pete*  
J. Michael Pete, Vice President

STATE OF PENNSYLVANIA SS

COUNTY OF PHILADELPHIA SS

I, Brian C. Kuhn, a Notary Public, do hereby certify that Martin J. Nilsen and J. Michael Pete personally known to me to be the same persons whose names are respectively as Secretary and Vice President of the Arch Insurance Company, a Corporation organized and existing under the laws of the State of Missouri, subscribed to the foregoing instrument, appeared before me this day in person and severally acknowledged that they being thereunto duly authorized signed, sealed with the corporate seal and delivered the said instrument as the free and voluntary act of said corporation and as their own free and voluntary acts for the uses and purposes therein set forth

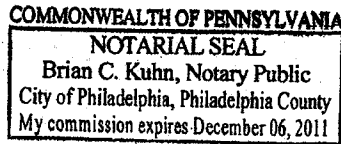

*Brian C. Kuhn*  
Brian C. Kuhn, Notary Public  
My commission expires 12-06-2011

CERTIFICATION

I, Martin J. Nilsen, Secretary of the Arch Insurance Company, do hereby certify that the attached Power of Attorney dated May 1, 2008 on behalf of the person(s) as listed above is a true and correct copy and that the same has been in full force and effect since the date thereof and is in full force and effect on the date of this certificate; and I do further certify that the said J. Michael Pete, who executed the Power of Attorney as Vice President, was on the date of execution of the attached Power of Attorney the duly elected Vice President of the Arch Insurance Company.

IN TESTIMONY WHEREOF, I have hereunto subscribed my name and affixed the corporate seal of the Arch Insurance Company on this \_\_\_\_\_ day of JAN 04 2011 20\_\_\_\_\_.

*Martin J. Nilsen*  
Martin J. Nilsen, Secretary

This Power of Attorney limits the acts of those named therein to the bonds and undertakings specifically named therein and they have no authority to bind the Company except in the manner and to the extent herein stated.

**PLEASE SEND ALL CLAIM INQUIRIES RELATING TO THIS BOND TO THE FOLLOWING ADDRESS:**

**Arch Contractors & Developers Group  
135 N. Robles Ave., Ste. 825  
Pasadena, CA 91101**





Fast-Track Construction Corporation  
5857 Uplander Way, Culver City, CA 90230-6607  
(310) 215-3099 Lic#674880

Riverside County Administration Center  
4080 Lemon Street, 1<sup>st</sup> Floor  
Riverside, CA 92501  
Attn: Clerk of the Board

RECEIVED RIV  
CLERK/BOARD

2011 JAN 11

Sealed by:

Project # FM0672000027

Title of Bid: CAC Parking Structure Solar  
System & Lighting Upgrade

Opening Time: January 12, 2011 at 2:00PM

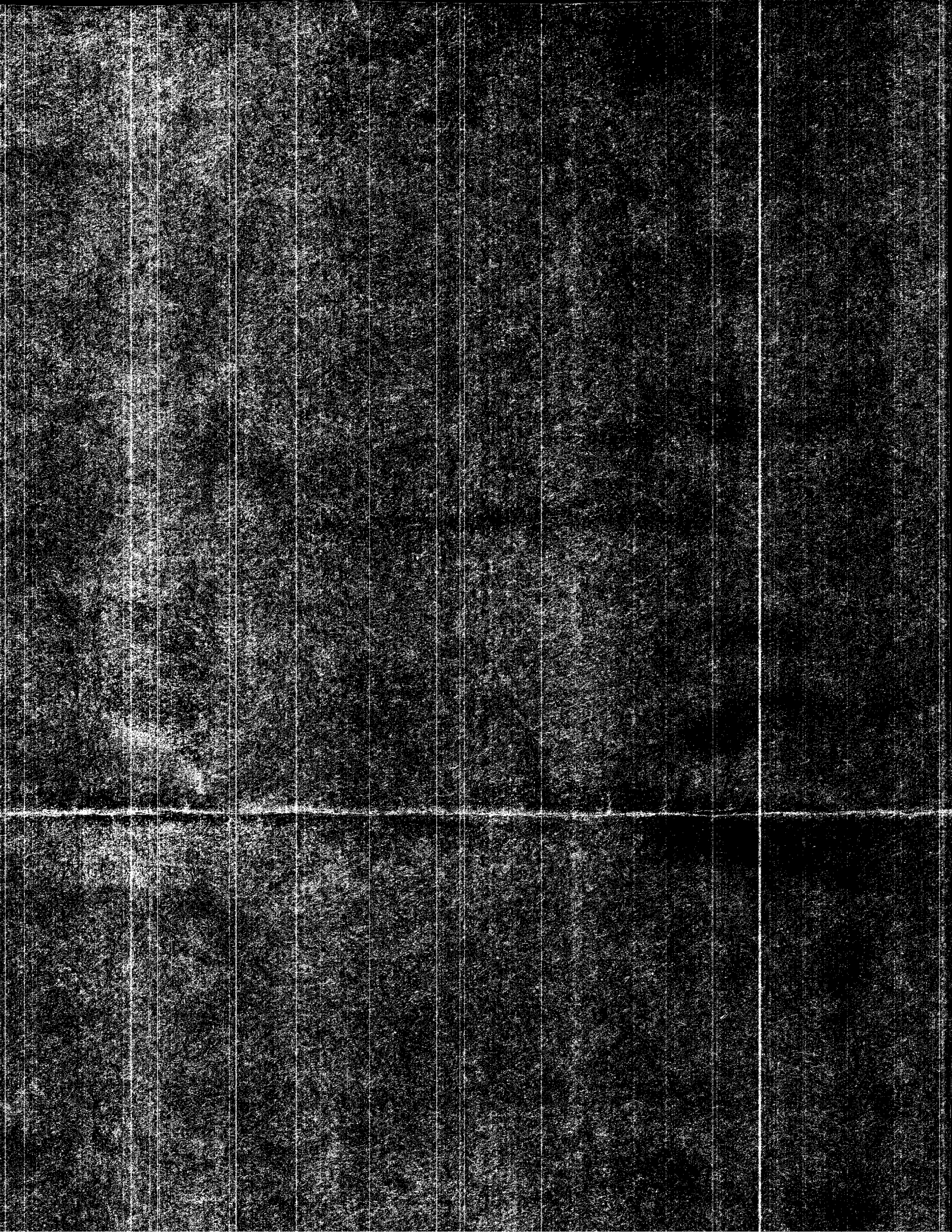

**CONTRACTOR'S PROPOSAL**

TO THE GOVERNING BOARD OF THE COUNTY OF RIVERSIDE:

Date: 1/12/2011

Bidder: AVI-CON, Inc. dba CA Construction

The undersigned, having carefully examined the proposed site and the Plans and Specifications, the Notice Inviting Bids, the Instructions to Bidders, the Agreement Form, the Bond Forms, the General Conditions for the Construction of the CAC Parking Structure Solar System & Lighting Upgrade, hereby proposes and agrees to furnish all tools, equipment, services, apparatus, facilities, transportation, labor and materials necessary to complete the work in strict conformity with the Plans and Specifications, including all work specified in Addenda numbered and dated:

One Million five hundred eleven thousand dollars and zero cents

Addendum No. 1 Date 12/6/2010  
Addendum No. 2 Date 12/30/2010  
Addendum No. 3 Date 1/3/2011

For the total Base Bid ~~One million three hundred thirty~~ Five hundred eleven thousand 1,511,000.<sup>00</sup> dollars (~~\$ 1,370,000.<sup>00</sup>~~), including all applicable taxes, permits, licenses, AND Course of Construction Insurance.

		(Add or Deduct state which)
Alternate 1	\$ <u>15,000.<sup>00</sup></u>	<u>Add (4 year Maintenance Plan)</u>
Alternate 2	\$ _____	_____
Alternate 3	\$ _____	_____
Alternate 4	\$ _____	_____

And,  
Cost of Contractor's Course of Construction Insurance Seven thousand dollars (\$ 7,000.<sup>00</sup>) and deductible \$ 10,000.<sup>00</sup>.

Bids must be submitted on all items. Failure to bid on all items may result in the bid being rejected as non-responsive. The basis for award will be the qualified bidder with the lowest total of the Base Bid WITH COURSE OF CONSTRUCTION INSURANCE and all alternates. Alternates may be awarded in any order after determination of the lowest responsible and responsive bidder.















**AWARD OF CONTRACT**

The undersigned fully understands that a Contract is formed upon the acceptance of this Proposal by the Owner and the undersigned further agrees that upon request he will promptly execute and deliver to Owner a written memorial of the Contract together with the required Payment and Performance Bonds and proof of insurance.

**BID GUARANTEE**

The enclosed certified or cashier's check or bidder's bond on approved form, made payable to the Owner in the amount of ten percent of the total bid submitted herewith, is hereby given as a guarantee that the bidder will execute and deliver the above mentioned written memorial and required bonds and insurance if awarded the contract, and in the event that the undersigned fails or refuses to execute and deliver said documents, such check or bond is to be charged with the costs of the damages experienced by the Owner as a result of such failure or refusal, including but not limited to publication costs, the difference in money between the amount of the bid of the said principal and the amount for which obligee may legally contract with another party to perform the said work if such amount be in excess of the former, building lease or rental costs, transportation costs and additional salary costs that result from the delay due to the principal's default on the awarded contract. In no event, however, shall the Surety's liability exceed the penal sum hereof.

Name of Bidder: AVI-CON, Inc. dba CA Construction  
Type of Organization: Corporation  
Signed By:   
Title of Signer: Charles Avila, President/CEO  
Address of Bidder: 981 Iowa Ave, Suite A  
Riverside, CA 92507  
Telephone No.: 951-781-8055  
Contractor's License No.: 588602  
Classification: A, B, D06 Expiration Date: 6/30/2012

Affix Seal  
If  
Corporation

**LICENSURE STATEMENTS ARE MADE UNDER PENALTY OF PERJURY**

If bidder is a corporation, and signer is not President or Secretary, attach a certified copy of By-Laws or resolution authorizing execution. If bidder is a corporation, affix corporate seal. If signer is an agent, attach Power of Attorney. If bidder is not an individual, list names of other persons authorized to bind the organization.

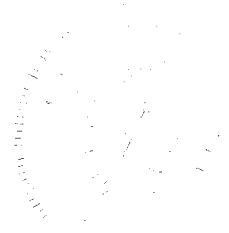

**NONCOLLUSION AFFIDAVIT TO BE EXECUTED BY BIDDER AND  
SUBMITTED WITH BID**

State of California ) ss.  
County of Riverside )

Charles Avila, being first duly sworn, deposes and says:

That he or she is President/CEO of AVI-CON, Inc. dba CA Construction the party making the foregoing bid; that the bid is not made in the interest of, or on behalf of, any undisclosed person, partnership, company, association, organization, or corporation; that the bid is genuine and not collusive or sham; that the bidder has not directly or indirectly induced or solicited any other bidder to put in a false or sham bid, and has not directly or indirectly colluded, conspired, connived, or agreed with any bidder or anyone else to put in a sham bid, or that anyone shall refrain from bidding; that the bidder has not in any manner, directly or indirectly, sought by agreement, communication, or conference with anyone to fix the bid price of the bidder or any other bidder, or to fix any overhead, profit, or cost element of the bid price, or of that of any other bidder, or to secure any advantage against the public body awarding the contract of anyone interested in the proposed contract; that all statements contained in the bid are true; and, further, that the bidder has not, directly or indirectly, submitted his or her bid price or any breakdown thereof, or the contents thereof, or divulged information or data relative thereto, or paid, and will not pay, any fee to any corporation, partnership, company, association, organization, bid depository, or to any member or agent thereof to effectuate a collusive or sham bid.

  
\_\_\_\_\_  
Signature  
Charles Avila, President/CEO

Subscribed and sworn to before me this 12 day of January, ~~2010~~ <sup>2011</sup>.

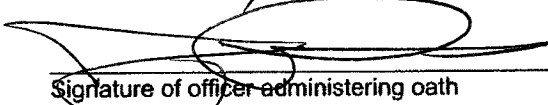
  
\_\_\_\_\_  
Signature of officer administering oath  
Jacob Avila, Secretary

**CALIFORNIA JURAT**

State of California

County of Riverside } SS.

Subscribed and sworn to (or affirmed) before me on this 12 day of January, 2011, by

(1) Charles Avila  
(name of signer(s))

(2) Jacob Avila  
(name of signer(s))

proved to me on the basis of satisfactory evidence to be the person(s) who appeared before me.

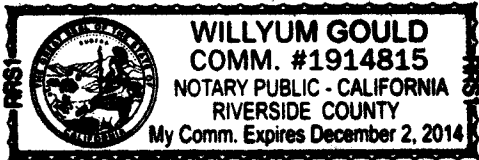

(seal)

Willyum Gould  
(signature of notary public)

**◆ OPTIONAL INFORMATION ◆**

Information below is NOT required by law however may deter fraudulent removal of this form.

DESCRIPTION OF ATTACHED DOCUMENT	RIGHT THUMBPRINT OF SIGNER	CAPACITY CLAIMED BY SIGNER(S)
<hr/> <p>(Title or type of document)</p>		<input type="checkbox"/> Individual(s) <input type="checkbox"/> Corporate Officer
<hr/> <p>(Title or type of document continued)</p>		<input type="checkbox"/> Partner
Number of pages _____ Document Date _____		<input type="checkbox"/> Attorney-in-Fact
<hr/> <p>(additional information)</p>		<input type="checkbox"/> Trustee(s) <input type="checkbox"/> Other: _____





**Bid Bond**

KNOWN TO ALL MEN BY THESE PRESENTS, that we, the undersigned AVI-CON, Inc.  
dba CA Construction, as Principal; and (1) \_\_\_\_\_, as Surety, are  
hereby held and firmly bound unto the County of Riverside, hereinafter called the "Owner", in the sum of  
(2) \_\_\_\_\_ Dollars (\$ ----- ) for the payment of such sum, well  
and truly to be made, do hereby jointly and severally bind ourselves, our heirs, executors, administrators,  
successors and assigns. (1) First National Insurance Company of America (2) not to exceed  
ten percent (10%) of the total bid amount  
WHEREAS, the said Principal is herewith submitting its Proposal for the  
US Department of Energy's Solar Projects CAC Parking Structure Solar System &  
Lighting Upgrade

THE CONDITION OF THE ABOVE OBLIGATION IS SUCH, that if the aforesaid Principal shall be awarded  
the Contract upon said Proposal and shall, within the required number of days after the notice of such award,  
execute a written memorial of the awarded Contract and submit the required Labor and Material Payment and  
faithful Performance Bond and proof of insurance, then this obligation shall be null and void; and in the event  
that the Principal fails and/or refuses to execute and deliver said documents this Bond will be charged with the  
costs of the damages experienced by the Owner as a result of such refusal, including but not limited to,  
publication cost, the difference in money between the amount of the bid of the said Principal and the amount  
for which the obligee may legally contract with another party to perform the said work if such amount be in  
excess of the former; building lease or rental costs, transportation cost, and additional salary costs that result  
from the delay due to the Principal's default on the awarded Contract. In no event however, shall the Surety's  
liability exceed the penal sum hereof.

The Surety, for value received, hereby stipulates and agrees that the obligations of said Surety and its bond  
shall be in no way impaired or affected by any extension of the time within which the Owner may accept such  
bid; and said Surety does hereby waive notice of any such extension.

IN WITNESS WHEREOF, the above bounded parties have executed this instrument under their separate  
seals this 27th day of December, 2010, the name and corporate seal of each corporate party  
being hereto affixed and those present duly signed by its undersigned representative, pursuant to authority of  
its governing body.

AVI-CON, Inc. dba CA Construction  
(Firm Name - Principal)

981 Iowa Ave, Suite A, Riverside, CA 92507  
(Business Address)

By [Signature]  
(Original Signature)

Charles Avila, President/CEO  
(Title)

First National Insurance Company of America  
(Corporation Name - Surety)

333 City Blvd. West, Suite 300, Orange, CA 92868  
(Business Address)

By [Signature]  
(Original Signature) Julia B. Gladding,  
Attorney-In-Fact

Affix Seal  
If  
Corporation

Affix  
Corporate  
Seal



POWER OF ATTORNEY

First National Insurance Company of America  
1001 4th Avenue  
Suite 1700  
Seattle, WA 98154

KNOW ALL BY THESE PRESENTS:

No. 12417

That FIRST NATIONAL INSURANCE COMPANY OF AMERICA, a Washington corporation, does hereby appoint

\*\*\*\*\*KENNETH A. COATE; JULIA B. GLADDING; Riverside, California\*\*\*\*\*

its true and lawful attorney(s)-in-fact, with full authority to execute on behalf of the company fidelity and surety bonds or undertakings and other documents of a similar character issued by the company in the course of its business, and to bind FIRST NATIONAL INSURANCE COMPANY OF AMERICA thereby as fully as if such instruments had been duly executed by its regularly elected officers at its home office.

IN WITNESS WHEREOF, FIRST NATIONAL INSURANCE COMPANY OF AMERICA has executed and attested these presents

this 21st day of March, 2009

Dexter R. Legg, Secretary

Timothy A. Mikolajewski, Vice President

CERTIFICATE

Extract from the By-Laws of FIRST NATIONAL INSURANCE COMPANY OF AMERICA:

"Article V, Section 13. - FIDELITY AND SURETY BONDS ... the President, any Vice President, the Secretary, and any Assistant Vice President appointed for that purpose by the officer in charge of surety operations, shall each have authority to appoint individuals as attorneys-in-fact or under other appropriate titles with authority to execute on behalf of the company fidelity and surety bonds and other documents of similar character issued by the company in the course of its business... On any instrument making or evidencing such appointment, the signatures may be affixed by facsimile. On any instrument conferring such authority or on any bond or undertaking of the company, the seal, or a facsimile thereof, may be impressed or affixed or in any other manner reproduced; provided, however, that the seal shall not be necessary to the validity of any such instrument or undertaking."

Extract from a Resolution of the Board of Directors of FIRST NATIONAL INSURANCE COMPANY OF AMERICA adopted July 28, 1970.

"On any certificate executed by the Secretary or an assistant secretary of the Company setting out,

- (i) The provisions of Article V, Section 13 of the By-Laws, and
- (ii) A copy of the power-of-attorney appointment, executed pursuant thereto, and
- (iii) Certifying that said power-of-attorney appointment is in full force and effect,

the signature of the certifying officer may be by facsimile, and the seal of the Company may be a facsimile thereof."

I, Dexter R. Legg, Secretary of FIRST NATIONAL INSURANCE COMPANY OF AMERICA, do hereby certify that the foregoing extracts of the By-Laws and of a Resolution of the Board of Directors of this corporation, and of a Power of Attorney issued pursuant thereto, are true and correct, and that both the By-Laws, the Resolution and the Power of Attorney are still in full force and effect.

IN WITNESS WHEREOF, I have hereunto set my hand and affixed the facsimile seal of said corporation

this DEC 27 2010 day of



Dexter R. Legg, Secretary

# CALIFORNIA ALL-PURPOSE ACKNOWLEDGMENT

State of California

County of Riverside



On DEC 27 2010 before me, Stephanie D. Montague, Notary Public  
Date Here Insert Name and Title of the Officer

personally appeared Julia B. Gladding  
Name(s) of Signer(s)

who proved to me on the basis of satisfactory evidence to be the person(s) whose name(s) is/are subscribed to the within instrument and acknowledged to me that he/she/they executed the same in his/her/their authorized capacity(ies), and that by his/her/their signature(s) on the instrument the person(s), or the entity upon behalf of which the person(s) acted, executed the instrument.

I certify under PENALTY OF PERJURY under the laws of the State of California that the foregoing paragraph is true and correct.

WITNESS my hand and official seal.

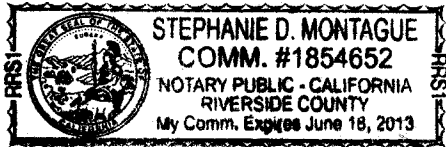

Place Notary Seal Above

Signature [Handwritten Signature]  
Signature of Notary Public

## OPTIONAL

*Though the information below is not required by law, it may prove valuable to persons relying on the document and could prevent fraudulent removal and reattachment of this form to another document.*

### Description of Attached Document

Title or Type of Document: \_\_\_\_\_

Document Date: \_\_\_\_\_ Number of Pages: \_\_\_\_\_

Signer(s) Other Than Named Above: \_\_\_\_\_

### Capacity(ies) Claimed by Signer(s)

Signer's Name: \_\_\_\_\_

- Individual
- Corporate Officer — Title(s): \_\_\_\_\_
- Partner —  Limited  General
- Attorney in Fact
- Trustee
- Guardian or Conservator
- Other: \_\_\_\_\_

Signer Is Representing: \_\_\_\_\_

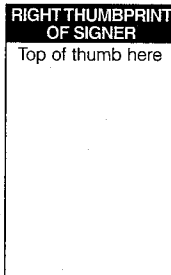

Signer's Name: \_\_\_\_\_

- Individual
- Corporate Officer — Title(s): \_\_\_\_\_
- Partner —  Limited  General
- Attorney in Fact
- Trustee
- Guardian or Conservator
- Other: \_\_\_\_\_

Signer Is Representing: \_\_\_\_\_

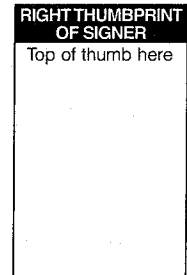

AVI-CON, INC.  
DBA CA CONSTRUCTION  
981 Iowa Ave, Suite A Riverside, CA 92507

US Dept. of Energy's Solar Projects  
CAC Parking Structure Solar System & Lighting Upgrade  
FM0672000027

Clerk of the Board  
1st Floor  
Riverside County Administration Center  
4080 Lemon Street  
Riverside, CA 92504

RECEIVED RIVERSIDE COUNTY  
CLERK / BOARD OF SUPERVISORS

2011 JAN 12 PM 1:43

SEALED BID RECEIVED  
CLERK OF THE BOARD OF SUPERVISORS