

GRADE

Performance graded (PG) asphalt binder shall conform to the following:

Property	AASHTO Test Method	Specification Grade		
		PG 64-10	PG 64-16	PG 70-10
Original Binder				
Flash Point, Minimum °C	T48	230	230	230
Solubility, Minimum % ^b	T44	99	99	99
Viscosity at 135 °C, Maximum, Pa's	T316	3.0	3.0	3.0
Dynamic Shear, Test Temp. at 10 rad/s, °C Minimum G*/sin(delta), kPa	T315	64 1.00	64 1.00	70 1.00
RTFO Test ^e , Mass Loss, Maximum, %	T240	1.00	1.00	1.00
RTFO Test Aged Binder				
Dynamic Shear, Test Temp. at 10 rad/s, °C Minimum G*/sin(delta), kPa	T315	64 2.20	64 2.20	70 2.20
Ductility at 25 °C Minimum, cm	T51	75	75	75
PAV ^f Aging, Temperature, °C	R28	100	100	110
RTFO Test and PAV Aged Binder				
Dynamic Shear, Test Temp. at 10 rad/s, °C Maximum G*/sin(delta), kPa	T315	31 ^d 5000	28 ^d 5000	34 ^d 5000
Creep Stiffness, Test Temperature, °C Maximum S-value, Mpa Minimum M-value	T313	0 300 0.300	-6 300 0.300	0 300 0.300

Notes:

- a. Note used.
- b. The Engineer will waive this specification if the supplier is a Quality Supplier as defined by Department's "Certification Program for Suppliers of Asphalt".
- c. The Engineer will waive this specification if the supplier certifies the asphalt binder can be adequately pumped and mixed at temperatures meeting applicable safety standards.
- d. Test the sample at 3 °C higher if it fails at the specified test temperature. G*/sin(delta) shall remain 5000 kPa maximum.
- e. "RTFO Test" means the asphaltic residue obtained using the Rolling Thin Film Oven Test, AASHTO Test Method T240 or ASTM Designation: D2827.
- f. "PAV" means Pressurized Aging Vessel.

Performance graded polymer modified asphalt binder (PG Polymer Modified) is:

Performance Graded Polymer Modified Asphalt Binder ^a

Property	AASHTO Test Method	Specification Grade		
		PG 58-34 PM	PG 64-28 PM	PG 76-22 PM
Original Binder				
Flash Point, Minimum °C	T 48	230	230	230
Solubility, Minimum % ^b	T 44 ^c	98.5	98.5	98.5
Viscosity at 135°C, ^d Maximum, Pa·s	T 316	3.0	3.0	3.0
Dynamic Shear, Test Temp. at 10 rad/s, °C Minimum G*/sin(delta), kPa	T 315	58 1.00	64 1.00	76 1.00
RTFO Test, Mass Loss, Maximum, %	T 240	1.00	1.00	1.00
RTFO Test Aged Binder				
Dynamic Shear, Test Temp. at 10 rad/s, °C Minimum G*/sin(delta), kPa	T 315	58 2.20	64 2.20	76 2.20
Dynamic Shear, Test Temp. at 10 rad/s, °C Maximum (delta), %	T 315	Note e 80	Note e 80	Note e 80
Elastic Recovery ^f , Test Temp., °C Minimum recovery, %	T 301	25 75	25 75	25 65
PAV ^g Aging, Temperature, °C	R 28	100	100	110
RTFO Test and PAV Aged Binder				
Dynamic Shear, Test Temp. at 10 rad/s, °C Maximum G*sin(delta), kPa	T 315	16 5000	22 5000	31 5000
Creep Stiffness, Test Temperature, °C Maximum S-value, MPa Minimum M-value	T 313	-24 300 0.300	-18 300 0.300	-12 300 0.300

Notes:

- a. Do not modify PG Polymer Modifier using acid modification.
- b. The Engineer waives this specification if the supplier is a Quality Supplier as defined by the Department's "Certification Program for Suppliers of Asphalt".
- c. The Department allows ASTM D5546 instead of AASHTO T44.
- d. The Engineer waives this specification if the supplier certifies the asphalt binder can be adequately pumped and mixed at temperatures meeting applicable safety standards.
- e. Test temperature is the temperature at which G*/sin(delta) is 2.2 kPa. A graph of log G*/sin(delta) plotted against temperature may be used to determine the test temperature when G*/sin(delta) is 2.2 Kpa. A graph of (delta) versus temperature may be used to determine delta at the temperature when G*/sin(delta) is 2.2 kPa. The Engineer also accepts direct measurement of (delta) at the temperature when G*/sin(delta) is 2.2 kPa.
- f. Test without a force ductility clamp may be performed.
- g. "PAV" means Pressurized Aging Vessel.

SAMPLING

Provide a sampling device in the asphalt feed line connecting the plant storage tanks to the asphalt weighing system or spray bar. Make the sampling device accessible between 24 and 30 inches above the platform. Provide a receptacle for flushing the sampling device.

Include with the sampling device a valve:

1. Between 1/2 and 3/4 inch in diameter;
2. Manufactured in a manner that a one-quart sample may be taken slowly at any time during plant operations;
3. Maintained in good condition.

The Contractor shall replace failed valves.

In the Engineer's presence, take 2 one-quart samples per operating day. Provide round, friction top, one-quart containers for storing samples.

APPLYING ASPHALT

Unless otherwise specified, the Contractor shall heat and apply asphalt in conformance with the provisions in Section 93, "Liquid Asphalts" of the Standard Specifications.

Section 39-2.01, "Asphalts" is replaced in its entirety with the following:

Asphalt binder to be mixed with aggregate shall conform to the provisions in "Asphalts" of these Special Provisions.

The grade of asphalt binder shall be 64-10 .

Liquid asphalt for prime coat shall conform to the provisions in Section 93, "Liquid Asphalts" of the Standard Specifications and shall be Grade 64-10 unless otherwise designated by the contract item or otherwise specified in the Special Provisions.

Asphaltic emulsion for paint binder (tack coat) shall conform to the provisions in Section 94, "Asphaltic Emulsion" of the Standard Specifications for the rapid-setting or slow-setting type and grade approved by the Engineer. Grade 64-10 shall be used if not otherwise specified.

Section 39-3.01B (1) shall be amended to include:

Aggregate of the 3/4 inch or 1/2 inch maximum size and aggregate for asphalt concrete base shall be separated into 3 or more sizes and each size shall be stored in separate bins. If 3 sizes are used, one bin shall contain that portion of the material which will pass the maximum size specified and be retained on a 3/8 inch sieve; one bin shall contain that

portion of the material which will pass a 3/8 inch sieve and be retained on a No. 8 sieve; and one bin shall contain that portion of the material which will pass a No. 8 sieve.

Aggregate of 3/8 inch maximum size shall be separated into 2 sizes and each size shall be stored in separate bins. One bin shall contain that portion of the material which will pass the maximum size specified and be retained on a No. 8 sieve and one bin shall contain that portion of the material which will pass a No. 8 sieve.

The bin containing the fine material shall not contain more than 15 percent of material retained on the No. 8 sieve. The material in any of the other bins shall not contain more than 15 percent of material passing a No. 8 sieve. Failure to comply with this requirement shall be corrected immediately, and the material in the bins not meeting these requirements shall be re-screened or wasted.

All asphalt concrete for this project shall be supplied from one source unless approved by the Engineer. Said source shall be listed on the Contractors Source of Materials List as required in Section 6 of the Standard Specifications.

Asphaltic emulsion shall be furnished and applied as provided in Section 39-4.02.

In addition to the provisions in Section 39-5.01, "Spreading Equipment" of the Standard Specifications, asphalt paving equipment shall be equipped with automatic screed controls and a sensing device or devices.

When placing asphalt concrete to the lines and grades established by the Engineer, the automatic controls shall control the longitudinal grade and transverse slope of the screed. Grade and slope references shall be furnished, installed, and maintained by the Contractor. Should the Contractor elect to use a ski device, the minimum length of the ski device shall be 30 feet. The ski device shall be a rigid one piece unit and the entire length shall be utilized in activating the sensor.

When placing the initial mat of asphalt concrete on existing pavement, the end of the screed nearest the centerline shall be controlled by a sensor activated by a ski device not less than 30 feet. The end of the screed farthest from centerline shall be controlled by an automatic transverse slope device set to reproduce the cross slope designated by the Engineer, by a sensor activated by a similar ski device or as directed by the Engineer.

When paving contiguously with previously placed mats, the end of the screed adjacent to the previously placed mat shall be controlled by a sensor that responds to the grade of the previously placed mat and will reproduce the grade in the new mat within a 0.12 inch tolerance. The end of the screed farthest from the previously placed mat shall be controlled in the same way it was controlled when placing the initial mat.

Should the methods and equipment furnished by the Contractor fail to produce a layer of asphalt concrete conforming to the provisions, including straightedge tolerance, of Section 39-6.03, "Compacting" of the Standard Specifications or elsewhere in these Special Provisions, the paving operations shall be discontinued and the Contractor shall modify the equipment or methods, or furnish substitute equipment.

Should the automatic screed controls fail to operate properly during a day's work, the Contractor may manually control the spreading equipment for the remainder of that day. However, the equipment shall be corrected or replaced with alternative automatically controlled equipment conforming to the provisions in this section before starting another day's work.

GENERAL CRITERIA FOR PROFILING

In addition to the straightedge provisions in Section 39-6.03, "Compacting" of the Standard Specifications, asphalt concrete pavement shall conform to the surface tolerances specified herein.

The uppermost layer of asphalt concrete surfacing shall be profiled in the presence of the Engineer using a California Profilograph or equivalent in conformance with California Test 526 and as specified in these Special Provisions.

The California Profilograph or equivalent will not be required for the following areas of the pavement surface but shall conform to the straightedge requirements in Section 39-6.03, "Compacting" of the Standard Specifications:

1. Pavement with a total thickness less than 0.24 foot;
2. Pavement on horizontal curves with a centerline curve radius of less than 1,000 feet and the pavement within the superelevation transition on those curves;
3. Pavement placed in a single lift when required by the Special Provisions;
4. Pavement with extensive grade or cross slope correction which does not receive advance leveling operations in conformance with the provisions in Section 39-6.02, "Spreading" of the Standard Specifications;
5. Pavement for ramps and connectors with steep grades and high rates of superelevation, as determined by the Engineer;
6. Shoulders and miscellaneous areas.

The Contractor shall conform to California Test 526, except a zero (null) blanking band shall be used for determining the Profile Index. Prior to beginning profiles, the profilograph shall be calibrated in the presence of the Engineer. Two profiles shall be obtained within each traffic lane, 3 feet from and parallel with the edges of the lane.

Pavements profiled shall conform to the following Profile Index requirements:

1. Pavement on tangent alignment and pavement on horizontal curves having a centerline curve radius of 2,000 feet or more shall have a Profile Index of 0.16 foot or less for each 330 feet section profiled;
2. Pavement on horizontal curves having a centerline curve radius of 1,000 feet or more but less than 2,000 feet, including the pavement within the superelevation transition

of these curves, shall have a Profile Index of 0.32 foot or less for each 330 feet section profile;

3. Pavement within any 330 feet section, containing high point areas with deviations in excess of 0.025 foot in a length of 25 feet or less, when tested in conformance with the requirements in California Test 526, shall be corrected by the Contractor regardless of the Profile Index.

The Contractor shall complete initial runs of the profilograph prior to opening the pavement to public traffic. If initial profiles can not be made prior to opening the pavement to public traffic, the initial runs of the profilograph shall be made the next day that traffic control is permitted for the area to be profiled.

Areas of the top surface of the uppermost layer of asphalt concrete pavement that do not meet the specified surface tolerances shall be brought within tolerance by abrasive grinding.

Abrasive grinding shall be performed to reduce individual deviations in excess of 0.025 foot, and to reduce the Profile Index of the pavement to be within the specified tolerance. Areas which have been subjected to abrasive grinding shall receive a seal coat. Deviations in excess of 0.025 foot which cannot be brought into specified tolerance by abrasive grinding shall be corrected by either (1) removal and replacement or (2) placing an overlay of asphalt concrete. The corrective method for each area shall be selected by the Contractor and shall be approved by the Engineer prior to beginning the corrective work. Replacement or overlay pavement not meeting the specified tolerances shall be corrected by the methods specified above. Corrective work shall be at the Contractor's expense. The Contractor shall run profilograms on the areas that have received abrasive grinding or corrective work until the final profilograms indicate the Profile Index of the area is within the specified tolerance.

When abrasive grinding is used to bring the top surface of the uppermost layer of asphalt concrete surfacing within the specified surface tolerances, additional abrasive grinding shall be performed as necessary to extend the area ground in each lateral direction so that the lateral limits of grinding are at a constant offset from, and parallel with, the nearest lane line or pavement edge, and in each longitudinal direction so that the grinding begins and ends at lines normal to the pavement centerline, within a ground area. Ground areas shall be neat rectangular areas of uniform surface appearance.

The original of the final profilograms that indicate the pavement surface is within the Profile Index specified shall become the property of the County and shall be delivered to the Engineer prior to acceptance of the contract.

PAYMENT

Asphalt concrete will be paid for at a unit price per ton as a combined item, including mineral aggregate and asphalt binder in place on the roadbed.

Full compensation for furnishing and applying asphaltic emulsion (paint binder) shall be considered as included in the contract price paid for Asphalt Concrete.

COMPENSATION ADJUSTMENTS FOR PRICE INDEX FLUCTUATIONS:

The provisions of this section shall apply only to the following contract items:

ITEM CODE	ITEM
390130	Hot Mix Asphalt

The compensation payable for asphalt binder used in hot mix asphalt and tack coat will be increased or decreased in conformance with the provisions of this section for paving asphalt price fluctuations exceeding 10 percent (Iu/Ib is greater than 1.10 or less than 0.90) which occur during performance of the work.

The quantity of asphalt binder used in tack coat will be determined by multiplying the item quantity for tack coat included in a monthly estimate by the minimum percent residue specified in Section 94, "Asphaltic Emulsions" of the Standard Specifications. The asphaltic emulsion minimum percent residue will be based on the type of emulsion used by the Contractor.

At the Contractor's option, the Contractor may provide actual daily test results for asphalt binder residue for the tack coat used. Test results provided by the Contractor shall be from an independent testing laboratory that participates in the AASHTO Proficiency Sample Program. The Contractor shall take samples of asphaltic emulsion from the distributor truck at mid-load from a sampling tap or thief. Two separate one-half (1/2) gallon samples shall be taken in the presence of the Engineer. The Contractor shall provide one sample to the Contractor's independent testing laboratory within 24 hours of sampling. The second sample shall be given to the Engineer. The test results from the Contractor independent testing laboratory shall be delivered to the Engineer within 10 days from sample date.

The adjustment in compensation will be determined in conformance with the following formulae when the item of hot mix asphalt or tack coat or both are included in a monthly estimate:

A. Total monthly adjustment = AQ

B. For an increase in paving asphalt price index exceeding 10 percent:

$$A = 0.90 (Iu/Ib - 1.10) Ib$$

C. For a decrease in paving asphalt price index exceeding 10 percent:

$$A = 0.90 (Iu/Ib - 0.90) Ib$$

D. Where:

A = Adjustment in dollars per ton of paving asphalt used to produce hot mix asphalt and asphaltic emulsion residue used as tack coat rounded to the nearest \$0.01.

Iu = The California Statewide Paving Asphalt Price Index which is in effect on the first business day of the month within the pay period in which the quantity subject to adjustment was included in the estimate.

Ib = The California Statewide Paving Asphalt Price Index for the month in which the bid opening for the project occurred.

Q = Quantity in tons of asphalt binder that was used in producing the quantity of hot mix asphalt shown under "This Estimate" on the monthly estimate using the amount of asphalt binder determined by the Engineer plus the quantity in tons of asphalt binder that would have been used as residue in the tack coat shown under "This Estimate" on the monthly estimate.

The adjustment in compensation will also be subject to the following:

- A. The compensation adjustments provided herein will be shown separately on payment estimates. The Contractor shall be liable to the State for decreased compensation adjustments and the Department may deduct the amount thereof from moneys due or that may become due the Contractor.
- B. Compensation adjustments made under this section will be taken into account in making adjustments in conformance with the provisions in Section 4-1.03B, "Increased or Decreased Quantities" of the Standard Specifications.
- C. In the event of an overrun of contract time, adjustment in compensation for paving asphalt included in estimates during the overrun period will be determined using the California Statewide Paving Asphalt Price Index in effect on the first business day of the month within the pay period in which the overrun began.

The California Statewide Paving Asphalt Price Index is determined each month on the first business day of the month by the Department using the median of posted prices in effect as posted by Chevron, Mobil, and Unocal for the Buena Vista, Huntington Beach, Kern River, Long Beach, Midway Sunset, and Wilmington fields.

In the event that the companies discontinue posting their prices for a field, the Department will determine an index from the remaining posted prices. The Department reserves the right to include in the index determination the posted prices of additional fields.

The California Statewide Paving Asphalt Price Index is available on the Division of Engineering Services website at: http://www.dot.ca.gov/hq/esc/oc/asphalt_index/astable.html.

FINISHING ROADWAY:

Finishing roadway shall conform to Section 22 of the Standard Specifications.

Full compensation, except as otherwise provided herein, for conforming to the requirements of this article shall be considered as included in the contract bid prices paid for the various items of work, and no additional compensation will be allowed therefor.

ASPHALT CONCRETE DIKE AND OVERSIDE DRAIN:

Asphalt concrete dikes shall be constructed in accordance to the County Road Standard Plans as specified and as directed by the Engineer.

The pay quantity of asphalt concrete dikes and overside drains, the placing of which are to be paid for as a separate item of work in addition to the price paid for the asphalt concrete material.

Object Marker shall be placed adjacent to overside drain per Caltrans Standard Drawings A73A Type L-1

The contract unit bid prices paid per linear foot for Asphalt Concrete Dike and per each for Asphalt Concrete Overside Drain, which prices shall include full compensation for furnishing all labor, material, tools, and equipment and doing all the work involved in placing and compacting, furnishing and installing Object Marker adjacent to overside drain and no additional compensation will be allowed therefor.

Asphalt binder to be mixed with the aggregate shall be PG 64-10 in accordance with the Special Provisions for Asphalts, or as directed by the Engineer.

REPAIR EXISTING CATCH BASIN:

Existing Catch basin shall be repaired with in-kind material and as directed by the Engineer.

Payment:

The unit price paid per each for repairing existing catch basin with in-kind material complete in place shall include full compensation for furnishing all labor, materials, tools, equipment and incidentals, and for doing all work involved and no additional compensation will be allowed.

MINOR CONCRETE (CROSS GUTTER, SPANDREL, CURB AND GUTTER, CURB RAMP):

Concrete cross gutter, spandrel, curb and gutter and curb ramps shall be constructed in accordance with the County Road Improvement Standards And Specifications, or as directed by the Engineer and in conformance with Section 51, 73 and 90 of Standard Specifications, except as here in modified:

Class 2 concrete shall be used for concrete cross-gutter and spandrel.

Class 3 concrete shall be used for curb and gutter, and curb ramps.

Preparation of subgrade for the concrete structures shall be done in conformance with the requirements of Section 73-1.02 of the Standard Specifications.

Excess material resulting from the excavation of the subgrade shall be disposed of as elsewhere provided in these Special Specifications. Full compensation for the removal of existing concrete structures shall be included in the contract bid prices for such items.

The Contractor is responsible for meeting requirements of all American with Disability Act (ADA).

Construction of curb ramps, cross gutter and spandrel shall include, but not be limited to, the following:

- 1) Removal and disposal of existing sidewalk, curb, and/or curb and gutter and existing soil and aggregate as required;
- 2) Remove the gravel behind the new, curb ramp and re-grade;
- 3) Establishing grades, and assuring that all grades are met;
- 4) Performing all grading and compaction – including all required aggregate import, as directed by the Engineer and in accordance with County Standard 403;
- 5) Construction of new curb, and curb ramps, cross gutter and spandrel;
- 6) All scoring/grooving and required saw cutting;
- 7) Repair of existing asphalt and PCC surfacing;
- 8) Installing 1/2" wide expansion joints;
- 9) All landscaping, and related work, to return the area adjacent to the curb ramp to its original condition and to conform the area to the new improvements;

At a minimum, the area from the BCR to ECR shall meet all required ADA standards. Therefore, to conform to existing conditions and/or to achieve the required four-foot level area (maximum of 2.0% crossfall) at the top portion of the curb ramp, it may be necessary to extend the work beyond the BCR/ECR in certain instances.

The area behind and along the curb ramps shall be filled and compacted with native or select material and graded to match and provide a smooth transition from the back of curb ramps, to the satisfaction of the Engineer.

Preparation of subgrade for the concrete structures shall be done in conformance with the requirements of Section 73-1.02 of the Standard Specifications.

Excess material resulting from the excavation of the subgrade shall be disposed of by the contractor.

Attention is directed to curb ramps detail shown on the plan (Sheet X-1). Full compensation for construction of Curb Ramp in conformance with the detail, including but not limited to removal of existing Guard Post, 6" curb behind the ramp, adjusting pull boxes and placement of Push Button and Posts shall be considered as included per unit price paid for bid item "Minor Concrete (Curb Ramp) [detail on X-1]".

Full compensation for concrete curb ramps shall include the removal and construction of the spandrel and no separate payment will be made.

Payment:

The contract unit bid prices paid per square foot for cross gutter and spandrel per linear foot for curb and gutter, and per each for curb ramp shall include full compensation for furnishing all labor, equipment, materials and tools, and incidentals, and for doing all the work involved including expansion joint material and steel joint dowels in the construction and complete in place, and no additional compensation will be allowed therefor.

GUARD POST:

Guard Post shall conform to the plans and these Special Provisions and as directed by the Engineer.

Payment:

The contract unit bid price paid per each for guard post as shown on the plans and as specified in the special provisions and as directed by the Engineer shall include full compensation for furnishing all labor, materials, tools, and equipment and no additional compensation will be allowed therefor."

RELOCATE ROADSIDE SIGNS:

Relocation of roadside signs shall conform to the provisions in Section 56-2, "Roadside Signs" of the Standard Specifications and as directed by the Engineer.

Roadside signs shall be relocated at the locations shown on the construction plans or where directed by the Engineer.

Payment:

The contract unit prices paid per each for relocating Roadside Signs shall include full compensation for furnishing all labor, materials, tools, equipment, and incidentals and for doing

all the work including all necessary concrete, excavation and backfill as specified in the Standard Specification and these Special Provisions and no additional compensation will be allowed therefor.

ADJUST MANHOLE TO GRADE:

Existing utilities cover or valves shall be adjusted to finish grade and new concrete collars poured with materials similar in quality to those in the original structure in accordance with the applicable provisions of Sections 15-2 and 71 of the Standard Specifications, the requirements of the owning utility company and these Special Provisions.

The owners of the facilities, will provide new manhole covers and frames as necessary for the project. The Contractor shall be responsible to coordinate with the owners to obtain the materials.

After the structure frame has been removed, the top of the structure shall be carefully trimmed to provide a suitable foundation for the new material.

Steel plates shall be used as necessary and when directed by the Engineer to prevent asphalt and debris from entering the sewer system.

After completion of the work, the structure covers, frames, grade rings and old concrete collar debris that were removed from the roadbed shall become the property of the Contractor.

Nothing in these Special Provisions shall relieve the Contractor from his responsibilities as provided in Section 7-1.09, "Public Safety" of the Standard Specifications.

The contract unit bid prices paid per each for such item shall include full compensation for furnishing all labor, materials, tools, equipment, and incidentals, for doing all the work involved and no additional compensation will be allowed therefor.

PEDESTRIAN PUSH BUTTONS

Pedestrian, bicycle, and equestrian push buttons shall conform to the provisions in Section 86-5.02, "Pedestrian Push Buttons", of the Standard Specifications and these Special Provisions.

Push button shall utilize solid state Piezo switch technology, shall be ADA compliant, and shall be constructed with high impact polycarbonate alloy blend material.

Push button assembly shall be Type B per Standard Plans ES-5C.

Push button housing shall be die-cast or permanent mold cast aluminum.

Push button sign shall be porcelain enameled metal.

Push button shall be Polara Engineering Inc. model MPBP-BY, Campbell Company TM Solid State model 700 or approved equal. The button shall be yellow and its outer body shall be black.

Payment:

Full compensation for furnishing and installing pedestrian push button complete system in place including all labor, materials, tools, and equipment, shall be considered as included per unit price bid for Minor Concrete (Curb Ramp) detail shown on plan (Sheet X-1) and no separate payment will be allowed therefor.

THERMOPLASTIC CROSSWALK AND PAVEMENT MARKING:

Thermoplastic crosswalk and pavement markings shall conform to the provisions in Sections 84-1, "General," and 84-2, "Thermoplastic Traffic Stripes and Pavement Markings," of the Standard Specifications and these Special Provisions.

Payment for Thermoplastic Crosswalk and Pavement Marking shall be paid by the square foot price bid and shall be considered as full compensation for furnishing all labor, materials, tools, equipment, and incidentals and doing all the work necessary including the placing of limit lines, and no additional compensation will be allowed.

PAINT TRAFFIC STRIPE:

Painting traffic stripe shall conform to the provisions in Sections 84-1, "General" and 84-3, "Painted Traffic Stripes and Pavement Markings" of the Standard Specifications and these Special Provisions.

Traffic striping shall be applied in two coats with airless equipment and shall be performed with a roadliner truck mounted striping machine. Where the configuration or location of a traffic stripe is such that the use of a roadliner truck mounted striping machine is unsuitable, traffic striping and glass spheres may be applied by other methods and equipment approved by the Engineer.

Newly painted traffic striping shall be protected from damage by public traffic or other causes until the paint is thoroughly dry. Any newly painted traffic striping which are damaged as a result of the construction, including wheel markings by public traffic and the construction equipment, shall be repainted by the Contractor and any associated removals shall be performed as called for in these Special Provisions.

The contract price paid per linear foot for Paint Traffic Stripe (2 Coats) shall include full compensation for furnishing all labor, materials, tools, equipment, and incidentals, and for doing all the work involved in painting traffic stripe (regardless of the number, widths, and types of individual stripes involved in each traffic stripe) including any necessary cat tracks, dribble lines any layout work, complete in place as shown on the plans, as specified in the Standard Specifications and these Special Provisions, and as directed by the Engineer.

PAVEMENT MARKERS AND DELINEATORS:

Markers and delineators shall conform to the provisions in Section 82, "Markers and Delineators" of the Standard Specifications and these Special Provisions.

Markers and delineators on flexible posts shall be made from a flexible white plastic which shall be resistant to impact, ultraviolet light, ozone and hydrocarbons. Flexible posts shall resist stiffening with age and shall be free of burns, discoloration, contamination, and other objectionable marks or defects which affect appearance or serviceability.

Retroreflective sheeting for metal and flexible target plates shall be the retroreflective sheeting designated for channelizers, markers, and delineators conforming to the requirements in ASTM Designation: D4956-95.

Payment:

The contract unit bid price paid per each for Delineator (Class 1) shall include full compensation for furnishing all labor, materials, tools, equipment including excavating and backfilling and no additional compensation will be allowed therefor.

DETECTORS LOOP:

Detectors shall conform to the provisions in Section 86-5, "Detectors", of the Standard Specifications and these Special Provisions.

Delay timers shall delay calls only during display of the associated red or yellow indications. If a vehicle departs the area of detection prior to expiration of the assigned delay period, the timer shall reset and no call shall be placed upon the controller. During display of the associated green indication, detectors shall operate in the present mode and calls shall not be delayed.

Inductive Loops

Detector loops' configuration shall be Type E unless otherwise shown on the construction plan, in the Special Provisions or as directed by the Engineer.

Limit Line detector loop configuration shall be modified Type E with diagonal saw cuts and wire winding conforming to Type D loop configuration.

Detector loops' wire shall be Type 2.

Detector loops' lead-in cable shall be Type B.

Detector loops' curb terminations shall be Type A in accordance with Standard Plans ES-5D. The conduit shall extend 18 inches into the paved roadway.

Loop sealant shall be the Hot-Melt Rubberized Asphalt sealant type, unless otherwise directed by the Engineer. Loop conductors and sealant shall be installed on the same day the loop slots are cut.

All detector loops shall be tested sequentially by the following methods:

- impedance (measured by megaohms)
- resistance (measured by ohms)
- inductance (measured in microhenries)

Payment:

The contract unit bid price paid per each for Detector Loops including the removal and disposal of existing detector loops as shown on the plans and as specified in the special provisions and as directed by the Engineer shall include full compensation for furnishing all labor, materials, tools, and equipment and no additional compensation will be allowed therefor.”

EXISTING HIGHWAY FACILITIES:

The work performed in connection with various existing highway facilities shall conform to the provisions in Section 15, "Existing Highway Facilities" of the Standard Specifications and these Special Provisions.

Except as otherwise provided for damaged materials in Section 15-2.04, "Salvage" of the Standard Specifications, the materials to be salvaged shall remain the property of the County, and shall be cleaned, packaged, bundled, tagged, and hauled to the County Maintenance Yard as directed and stockpiled.

Payment:

Full compensation, except as otherwise provided herein, for conforming to the requirements of this article including transportation, furnishing all labor, materials, tools, equipment, and incidentals and for doing all the required work, shall be considered as included in the various items of work, and no additional compensation will be allowed therefor.

APPENDIX A

Attachment "C" for Risk Level 1 Requirements

Of Water Pollution Control

ATTACHMENT C RISK LEVEL 1 REQUIREMENTS

A. Effluent Standards

[These requirements are the same as those in the General Permit order.]

1. Narrative – Risk Level 1 dischargers shall comply with the narrative effluent standards listed below:
 - a. Storm water discharges and authorized non-storm water discharges regulated by this General Permit shall not contain a hazardous substance equal to or in excess of reportable quantities established in 40 C.F.R. §§ 117.3 and 302.4, unless a separate NPDES Permit has been issued to regulate those discharges.
 - b. Dischargers shall minimize or prevent pollutants in storm water discharges and authorized non-storm water discharges through the use of controls, structures, and management practices that achieve BAT for toxic and non-conventional pollutants and BCT for conventional pollutants.
2. Numeric – Risk Level 1 dischargers are not subject to a numeric effluent standard.

B. Good Site Management "Housekeeping"

1. Risk Level 1 dischargers shall implement good site management (i.e., "housekeeping") measures for construction materials that could potentially be a threat to water quality if discharged. At a minimum, Risk Level 1 dischargers shall implement the following good housekeeping measures:
 - a. Conduct an inventory of the products used and/or expected to be used and the end products that are produced and/or expected to be produced. This does not include materials and equipment that are designed to be outdoors and exposed to environmental conditions (i.e. poles, equipment pads, cabinets, conductors, insulators, bricks, etc.).
 - b. Cover and berm loose stockpiled construction materials that are not actively being used (i.e. soil, spoils, aggregate, fly-ash, stucco, hydrated lime, etc.).

- c. Store chemicals in watertight containers (with appropriate secondary containment to prevent any spillage or leakage) or in a storage shed (completely enclosed).
 - d. Minimize exposure of construction materials to precipitation. This does not include materials and equipment that are designed to be outdoors and exposed to environmental conditions (i.e. poles, equipment pads, cabinets, conductors, insulators, bricks, etc.).
 - e. Implement BMPs to prevent the off-site tracking of loose construction and landscape materials.
2. Risk Level 1 dischargers shall implement good housekeeping measures for waste management, which, at a minimum, shall consist of the following:
- a. Prevent disposal of any rinse or wash waters or materials on impervious or pervious site surfaces or into the storm drain system.
 - b. Ensure the containment of sanitation facilities (e.g., portable toilets) to prevent discharges of pollutants to the storm water drainage system or receiving water.
 - c. Clean or replace sanitation facilities and inspecting them regularly for leaks and spills.
 - d. Cover waste disposal containers at the end of every business day and during a rain event.
 - e. Prevent discharges from waste disposal containers to the storm water drainage system or receiving water.
 - f. Contain and securely protect stockpiled waste material from wind and rain at all times unless actively being used.
 - g. Implement procedures that effectively address hazardous and non-hazardous spills.
 - h. Develop a spill response and implementation element of the SWPPP prior to commencement of construction activities. The SWPPP shall require that:
 - i. Equipment and materials for cleanup of spills shall be available on site and that spills and leaks shall be cleaned up immediately and disposed of properly; and

- ii. Appropriate spill response personnel are assigned and trained.
 - i. Ensure the containment of concrete washout areas and other washout areas that may contain additional pollutants so there is no discharge into the underlying soil and onto the surrounding areas.
3. Risk Level 1 dischargers shall implement good housekeeping for vehicle storage and maintenance, which, at a minimum, shall consist of the following:
 - a. Prevent oil, grease, or fuel to leak in to the ground, storm drains or surface waters.
 - b. Place all equipment or vehicles, which are to be fueled, maintained and stored in a designated area fitted with appropriate BMPs.
 - c. Clean leaks immediately and disposing of leaked materials properly.
4. Risk Level 1 dischargers shall implement good housekeeping for landscape materials, which, at a minimum, shall consist of the following:
 - a. Contain stockpiled materials such as mulches and topsoil when they are not actively being used.
 - b. Contain fertilizers and other landscape materials when they are not actively being used.
 - c. Discontinue the application of any erodible landscape material within 2 days before a forecasted rain event or during periods of precipitation.
 - d. Apply erodible landscape material at quantities and application rates according to manufacture recommendations or based on written specifications by knowledgeable and experienced field personnel.
 - e. Stack erodible landscape material on pallets and covering or storing such materials when not being used or applied.
5. Risk Level 1 dischargers shall conduct an assessment and create a list of potential pollutant sources and identify any areas of the site where additional BMPs are necessary to reduce or prevent pollutants in storm water discharges and authorized non-storm water discharges. This potential pollutant list shall be kept with the SWPPP and shall identify

all non-visible pollutants which are known, or should be known, to occur on the construction site. At a minimum, when developing BMPs, Risk Level 1 dischargers shall do the following:

- a. Consider the quantity, physical characteristics (e.g., liquid, powder, solid), and locations of each potential pollutant source handled, produced, stored, recycled, or disposed of at the site.
 - b. Consider the degree to which pollutants associated with those materials may be exposed to and mobilized by contact with storm water.
 - c. Consider the direct and indirect pathways that pollutants may be exposed to storm water or authorized non-storm water discharges. This shall include an assessment of past spills or leaks, non-storm water discharges, and discharges from adjoining areas.
 - d. Ensure retention of sampling, visual observation, and inspection records.
 - e. Ensure effectiveness of existing BMPs to reduce or prevent pollutants in storm water discharges and authorized non-storm water discharges.
6. Risk Level 1 dischargers shall implement good housekeeping measures on the construction site to control the air deposition of site materials and from site operations. Such particulates can include, but are not limited to, sediment, nutrients, trash, metals, bacteria, oil and grease and organics.

C. Non-Storm Water Management

1. Risk Level 1 dischargers shall implement measures to control all non-storm water discharges during construction.
2. Risk Level 1 dischargers shall wash vehicles in such a manner as to prevent non-storm water discharges to surface waters or MS4 drainage systems.
3. Risk Level 1 dischargers shall clean streets in such a manner as to prevent unauthorized non-storm water discharges from reaching surface water or MS4 drainage systems.

D. Erosion Control

1. Risk Level 1 dischargers shall implement effective wind erosion control.
2. Risk Level 1 dischargers shall provide effective soil cover for inactive¹ areas and all finished slopes, open space, utility backfill, and completed lots.
3. Risk Level 1 dischargers shall limit the use of plastic materials when more sustainable, environmentally friendly alternatives exist. Where plastic materials are deemed necessary, the discharger shall consider the use of plastic materials resistant to solar degradation.

E. Sediment Controls

1. Risk Level 1 dischargers shall establish and maintain effective perimeter controls and stabilize all construction entrances and exits to sufficiently control erosion and sediment discharges from the site.
2. On sites where sediment basins are to be used, Risk Level 1 dischargers shall, at minimum, design sediment basins according to the method provided in CASQA's Construction BMP Guidance Handbook.

F. Run-on and Runoff Controls

Risk Level 1 dischargers shall effectively manage all run-on, all runoff within the site and all runoff that discharges off the site. Run-on from off site shall be directed away from all disturbed areas or shall collectively be in compliance with the effluent limitations in this General Permit.

G. Inspection, Maintenance and Repair

1. Risk Level 1 dischargers shall ensure that all inspection, maintenance repair and sampling activities at the project location shall be performed or supervised by a Qualified SWPPP Practitioner (QSP) representing the discharger. The QSP may delegate any or all of these activities to an employee trained to do the task(s) appropriately, but shall ensure adequate deployment.
2. Risk Level 1 dischargers shall perform weekly inspections and observations, and at least once each 24-hour period during extended

¹ Inactive areas of construction are areas of construction activity that have been disturbed and are not scheduled to be re-disturbed for at least 14 days.

storm events, to identify and record BMPs that need maintenance to operate effectively, that have failed, or that could fail to operate as intended. Inspectors shall be the QSP or be trained by the QSP.

3. Upon identifying failures or other shortcomings, as directed by the QSP, Risk Level 1 dischargers shall begin implementing repairs or design changes to BMPs within 72 hours of identification and complete the changes as soon as possible.
4. For each inspection required, Risk Level 1 dischargers shall complete an inspection checklist, using a form provided by the State Water Board or Regional Water Board or in an alternative format.
5. Risk Level 1 dischargers shall ensure that checklists shall remain onsite with the SWPPP and at a minimum, shall include:
 - a. Inspection date and date the inspection report was written.
 - b. Weather information, including presence or absence of precipitation, estimate of beginning of qualifying storm event, duration of event, time elapsed since last storm, and approximate amount of rainfall in inches.
 - c. Site information, including stage of construction, activities completed, and approximate area of the site exposed.
 - d. A description of any BMPs evaluated and any deficiencies noted.
 - e. If the construction site is safely accessible during inclement weather, list the observations of all BMPs: erosion controls, sediment controls, chemical and waste controls, and non-storm water controls. Otherwise, list the results of visual inspections at all relevant outfalls, discharge points, downstream locations and any projected maintenance activities.
 - f. Report the presence of noticeable odors or of any visible sheen on the surface of any discharges.
 - g. Any corrective actions required, including any necessary changes to the SWPPP and the associated implementation dates.
 - h. Photographs taken during the inspection, if any.
 - i. Inspector's name, title, and signature.

H. Rain Event Action Plan

Not required for Risk Level 1 dischargers.

I. Risk Level 1 Monitoring and Reporting Requirements

Table 1- Summary of Monitoring Requirements

Risk Level	Visual Inspections					Sample Collection	
	Quarterly Non-Storm Water Discharge	Pre-Storm Even		Daily Storm BMP	Post-Storm	Storm Water Discharge	Receiving Water
		Baseline	PEAP				
1	X	X		X	X		

1. Construction Site Monitoring Program Requirements

- a. Pursuant to Water Code Sections 13383 and 13267, all dischargers subject to this General Permit shall develop and implement a written site-specific Construction Site Monitoring Program (CSMP) in accordance with the requirements of this Section. The CSMP shall include all monitoring procedures and instructions, location maps, forms, and checklists as required in this section. The CSMP shall be developed prior to the commencement of construction activities, and revised as necessary to reflect project revisions. The CSMP shall be a part of the Storm Water Pollution Prevention Plan (SWPPP), included as an appendix or separate SWPPP chapter.
- b. Existing dischargers registered under the State Water Board Order No. 99-08-DWQ shall make and implement necessary revisions to their Monitoring Programs to reflect the changes in this General Permit in a timely manner, but no later than July 1, 2010. Existing dischargers shall continue to implement their existing Monitoring Programs in compliance with State Water Board Order No. 99-08-DWQ until the necessary revisions are completed according to the schedule above.
- c. When a change of ownership occurs for all or any portion of the construction site prior to completion or final stabilization, the new discharger shall comply with these requirements as of the date the ownership change occurs.

2. Objectives

The CSMP shall be developed and implemented to address the following objectives:

- a. To demonstrate that the site is in compliance with the Discharge Prohibitions;

- b. To determine whether non-visible pollutants are present at the construction site and are causing or contributing to exceedances of water quality objectives;
- c. To determine whether immediate corrective actions, additional Best Management Practice (BMP) implementation, or SWPPP revisions are necessary to reduce pollutants in storm water discharges and authorized non-storm water discharges; and
- d. To determine whether BMPs included in the SWPPP are effective in preventing or reducing pollutants in storm water discharges and authorized non-storm water discharges.

3. Risk Level 1 - Visual Monitoring (Inspection) Requirements for Qualifying Rain Events

- a. Risk Level 1 dischargers shall visually observe (inspect) storm water discharges at all discharge locations within two business days (48 hours) after each qualifying rain event.
- b. Risk Level 1 dischargers shall visually observe (inspect) the discharge of stored or contained storm water that is derived from and discharged subsequent to a qualifying rain event producing precipitation of ½ inch or more at the time of discharge. Stored or contained storm water that will likely discharge after operating hours due to anticipated precipitation shall be observed prior to the discharge during operating hours.
- c. Risk Level 1 dischargers shall conduct visual observations (inspections) during business hours only.
- d. Risk Level 1 dischargers shall record the time, date and rain gauge reading of all qualifying rain events.
- e. Within 2 business days (48 hours) prior to each qualifying rain event, Risk Level 1 dischargers shall visually observe (inspect):
 - i. All storm water drainage areas to identify any spills, leaks, or uncontrolled pollutant sources. If needed, the discharger shall implement appropriate corrective actions.
 - ii. All BMPs to identify whether they have been properly implemented in accordance with the SWPPP. If needed, the discharger shall implement appropriate corrective actions.

- iii. Any storm water storage and containment areas to detect leaks and ensure maintenance of adequate freeboard.
- f. For the visual observations (inspections) described in e.i and e.iii above, Risk Level 1 dischargers shall observe the presence or absence of floating and suspended materials, a sheen on the surface, discolorations, turbidity, odors, and source(s) of any observed pollutants.
- g. Within two business days (48 hours) after each qualifying rain event, Risk Level 1 dischargers shall conduct post rain event visual observations (inspections) to (1) identify whether BMPs were adequately designed, implemented, and effective, and (2) identify additional BMPs and revise the SWPPP accordingly.
- h. Risk Level 1 dischargers shall maintain on-site records of all visual observations (inspections), personnel performing the observations, observation dates, weather conditions, locations observed, and corrective actions taken in response to the observations.

4. Risk Level 1 – Visual Observation Exemptions

- a. Risk Level 1 dischargers shall be prepared to conduct visual observation (inspections) until the minimum requirements of Section I.3 above are completed. Risk Level 1 dischargers are not required to conduct visual observation (inspections) under the following conditions:
 - i. During dangerous weather conditions such as flooding and electrical storms.
 - ii. Outside of scheduled site business hours.
- b. If no required visual observations (inspections) are collected due to these exceptions, Risk Level 1 dischargers shall include an explanation in their SWPPP and in the Annual Report documenting why the visual observations (inspections) were not conducted.

5. Risk Level 1 – Monitoring Methods

Risk Level 1 dischargers shall include a description of the visual observation locations, visual observation procedures, and visual observation follow-up and tracking procedures in the CSMP.

6. Risk Level 1 – Non-Storm Water Discharge Monitoring Requirements

- a. Visual Monitoring Requirements:
 - i. Risk Level 1 dischargers shall visually observe (inspect) each drainage area for the presence of (or indications of prior) unauthorized and authorized non-storm water discharges and their sources.
 - ii. Risk Level 1 dischargers shall conduct one visual observation (inspection) quarterly in each of the following periods: January-March, April-June, July-September, and October-December. Visual observation (inspections) are only required during daylight hours (sunrise to sunset).
 - iii. Risk Level 1 dischargers shall ensure that visual observations (inspections) document the presence or evidence of any non-storm water discharge (authorized or unauthorized), pollutant characteristics (floating and suspended material, sheen, discoloration, turbidity, odor, etc.), and source. Risk Level 1 dischargers shall maintain on-site records indicating the personnel performing the visual observation (inspections), the dates and approximate time each drainage area and non-storm water discharge was observed, and the response taken to eliminate unauthorized non-storm water discharges and to reduce or prevent pollutants from contacting non-storm water discharges.

7. Risk Level 1 – Non-Visible Pollutant Monitoring Requirements

- a. Risk Level 1 dischargers shall collect one or more samples during any breach, malfunction, leakage, or spill observed during a visual inspection which could result in the discharge of pollutants to surface waters that would not be visually detectable in storm water.
- b. Risk Level 1 dischargers shall ensure that water samples are large enough to characterize the site conditions.
- c. Risk Level 1 dischargers shall collect samples at all discharge locations that can be safely accessed.
- d. Risk Level 1 dischargers shall collect samples during the first two hours of discharge from rain events that occur during business hours and which generate runoff.
- e. Risk Level 1 dischargers shall analyze samples for all non-visible pollutant parameters (if applicable) - parameters indicating the

presence of pollutants identified in the pollutant source assessment required (Risk Level 1 dischargers shall modify their CSMPs to address these additional parameters in accordance with any updated SWPPP pollutant source assessment).

- f. Risk Level 1 dischargers shall collect a sample of storm water that has not come in contact with the disturbed soil or the materials stored or used on-site (uncontaminated sample) for comparison with the discharge sample.
- g. Risk Level 1 dischargers shall compare the uncontaminated sample to the samples of discharge using field analysis or through laboratory analysis.²
- h. Risk Level 1 dischargers shall keep all field /or analytical data in the SWPPP document.

8. Risk Level 1 – Particle Size Analysis for Project Risk Justification

Risk Level 1 dischargers justifying an alternative project risk shall report a soil particle size analysis used to determine the RUSLE K-Factor. ASTM D-422 (Standard Test Method for Particle-Size Analysis of Soils), as revised, shall be used to determine the percentages of sand, very fine sand, silt, and clay on the site.

9. Risk Level 1 – Records

Risk Level 1 dischargers shall retain records of all storm water monitoring information and copies of all reports (including Annual Reports) for a period of at least three years. Risk Level 1 dischargers shall retain all records on-site while construction is ongoing. These records include:

- a. The date, place, time of facility inspections, sampling, visual observation (inspections), and/or measurements, including precipitation.
- b. The individual(s) who performed the facility inspections, sampling, visual observation (inspections), and or measurements.
- c. The date and approximate time of analyses.
- d. The individual(s) who performed the analyses.

² For laboratory analysis, all sampling, sample preservation, and analyses must be conducted according to test procedures under 40 CFR Part 136. Field discharge samples shall be collected and analyzed according to the specifications of the manufacturer of the sampling devices employed.

- e. A summary of all analytical results from the last three years, the method detection limits and reporting units, and the analytical techniques or methods used.
- f. Rain gauge readings from site inspections.
- g. Quality assurance/quality control records and results.
- h. Non-storm water discharge inspections and visual observation (inspections) and storm water discharge visual observation records (see Sections 1.3 and 1.6 above).
- i. Visual observation and sample collection exception records (see Section 1.4 above).
- j. The records of any corrective actions and follow-up activities that resulted from analytical results, visual observation (inspections), or inspections.

REFERENCE DRAWINGS

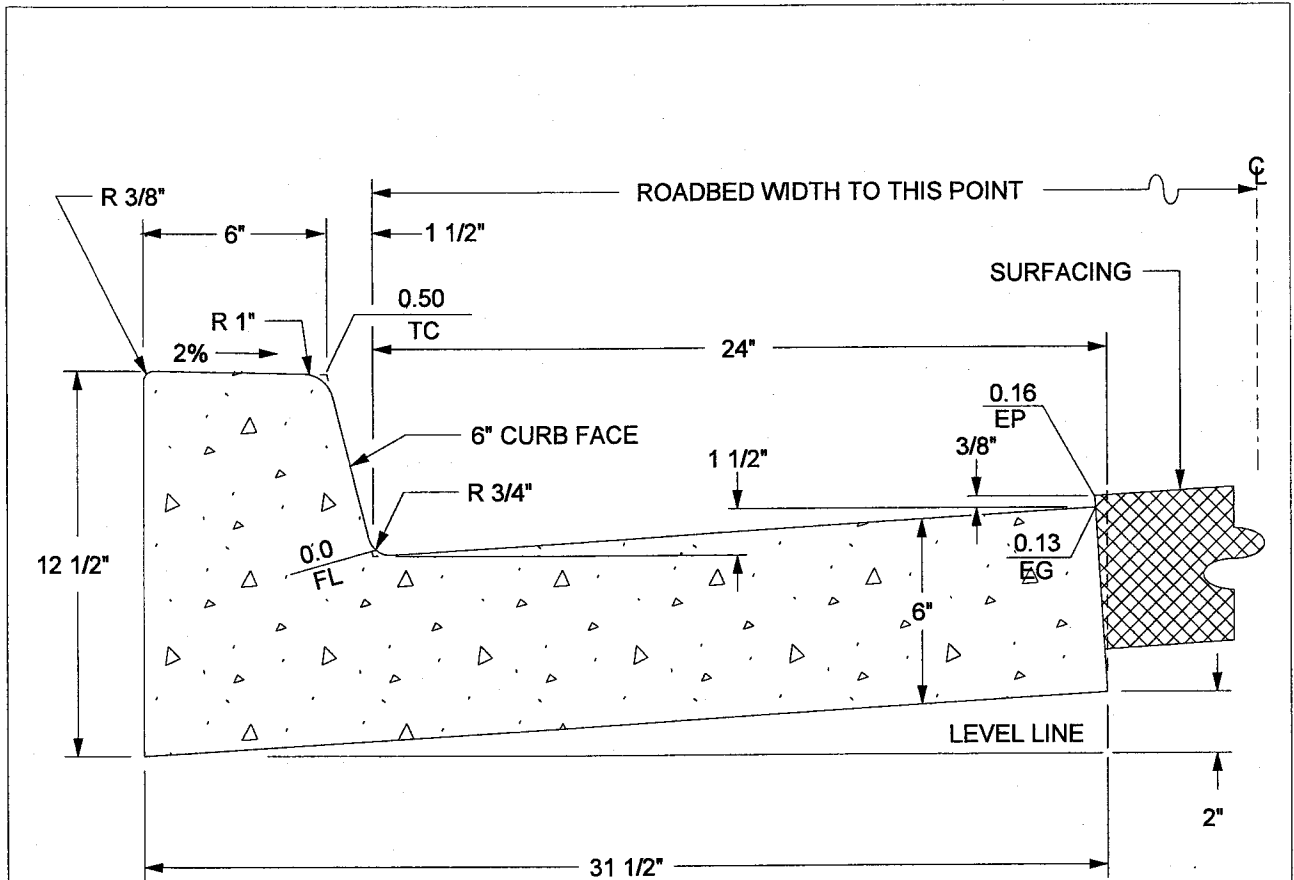

CLASS "B" CONCRETE

1.601 CU. FT. / L.F.

1 CU. YD. = 16.86 L.F.

ABBREVIATIONS:

TC = TOP OF CURB

FL = FLOWLINE

EG = EDGE OF GUTTER

EP = EDGE OF PAVEMENT

APPROVED BY:

George A. Johnson
 DIRECTOR OF TRANSPORTATION
 GEORGE A. JOHNSON, RCE 42328

DATE: 05/01/07

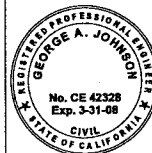

COUNTY OF RIVERSIDE

TYPE A-6 CURB

REVISIONS	REV.	BY:	APR'D	DATE	REV.	BY:	APR'D	DATE
8-71, 9-88	1				4			
2-90, 11-04	2				5			
	3				6			

STANDARD NO. 200

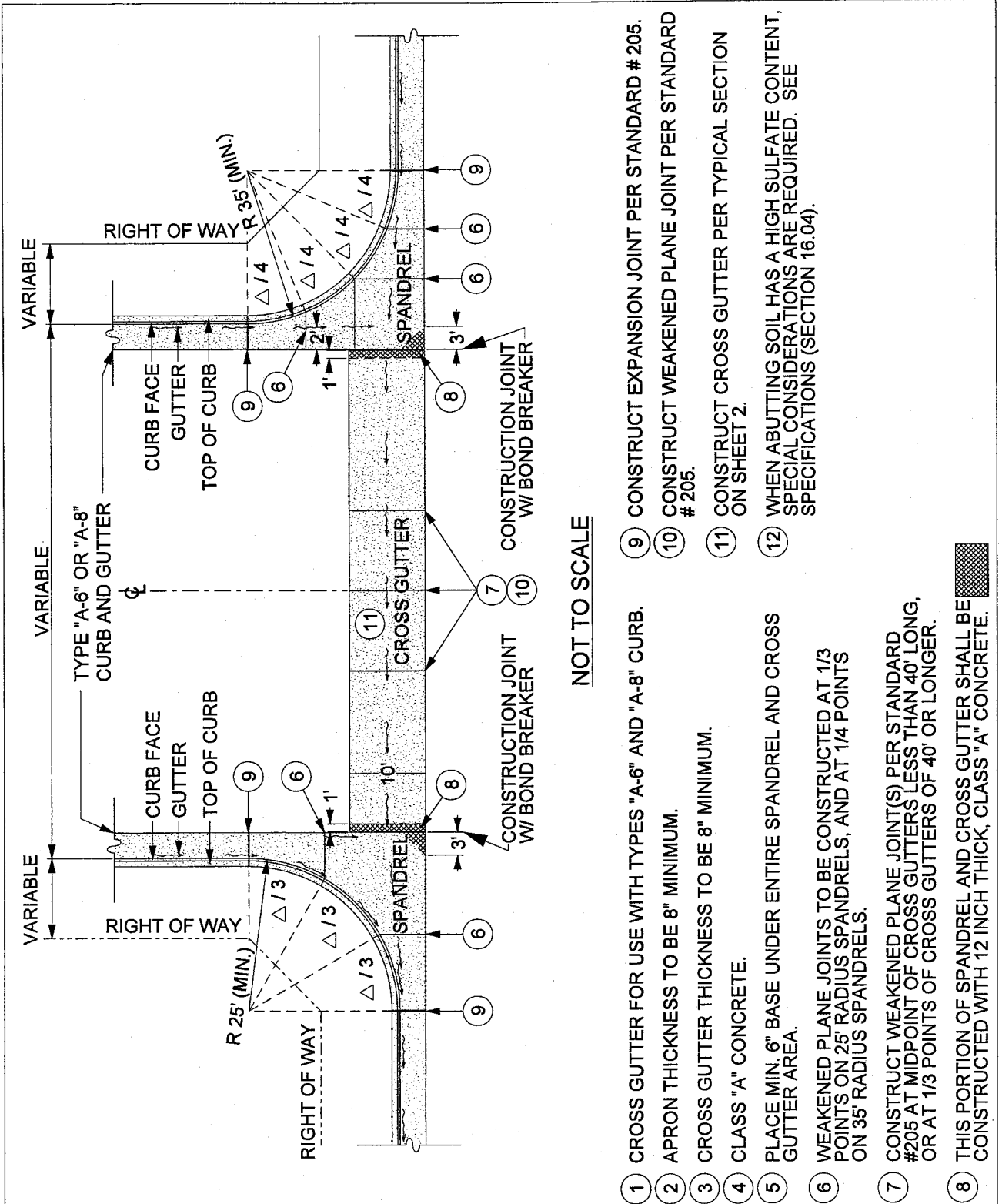

APPROVED BY:

George A. Johnson
 DIRECTOR OF TRANSPORTATION
 GEORGE A. JOHNSON, RCE 42328

DATE: 05/01/07

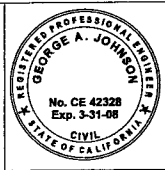

COUNTY OF RIVERSIDE

**CROSS GUTTER
(LAYOUT)**

STANDARD NO. 209 (1 OF 2)

REVISIONS	REV.	BY:	APR'D	DATE	REV.	BY:	APR'D	DATE
11-77, 8-82	1				4			
9-88, 2-90	2				5			
11-04	3				6			

- 1 CROSS GUTTER FOR USE WITH TYPES "A-6" AND "A-8" CURB.
- 2 APRON THICKNESS TO BE 8" MINIMUM.
- 3 CROSS GUTTER THICKNESS TO BE 8" MINIMUM.
- 4 CLASS "A" CONCRETE.
- 5 PLACE MIN. 6" BASE UNDER ENTIRE SPANDREL AND CROSS GUTTER AREA.
- 6 WEAKENED PLANE JOINTS TO BE CONSTRUCTED AT 1/3 POINTS ON 25' RADIUS SPANDRELS, AND AT 1/4 POINTS ON 35' RADIUS SPANDRELS.
- 7 CONSTRUCT WEAKENED PLANE JOINT(S) PER STANDARD #205 AT MIDPOINT OF CROSS GUTTERS LESS THAN 40' LONG, OR AT 1/3 POINTS OF CROSS GUTTERS OF 40' OR LONGER.
- 8 THIS PORTION OF SPANDREL AND CROSS GUTTER SHALL BE CONSTRUCTED WITH 12 INCH THICK, CLASS "A" CONCRETE.
- 9 CONSTRUCT EXPANSION JOINT PER STANDARD # 205.
- 10 CONSTRUCT WEAKENED PLANE JOINT PER STANDARD # 205.
- 11 CONSTRUCT CROSS GUTTER PER TYPICAL SECTION ON SHEET 2.
- 12 WHEN ABUTTING SOIL HAS A HIGH SULFATE CONTENT, SPECIAL CONSIDERATIONS ARE REQUIRED. SEE SPECIFICATIONS (SECTION 16.04).

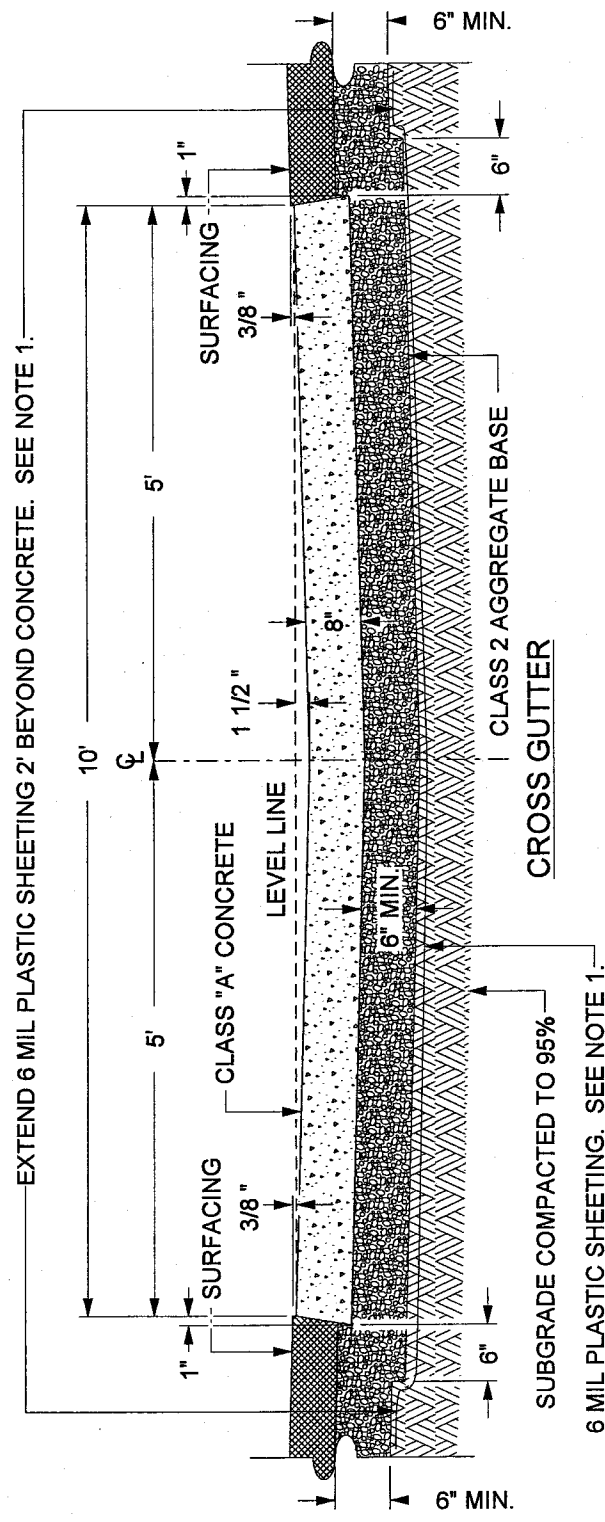

NOT TO SCALE

NOTE
 1. WHEN ABUTTING SOIL HAS A HIGH SULFATE CONTENT, SPECIAL CONSIDERATIONS ARE REQUIRED. SEE SPECIFICATIONS (SECTION 16.04).

APPROVED BY:
George A. Johnson DATE: 05/01/07
 DIRECTOR OF TRANSPORTATION
 GEORGE A. JOHNSON, RCE 42328

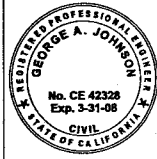

COUNTY OF RIVERSIDE

**CROSS GUTTER
 (TYPICAL SECTION)**

REVISIONS				REV.	BY:	APR'D	DATE	REV.	BY:	APR'D	DATE
8-71, 9-88				1				4			
2-90, 12-97				2				5			
11-04				3				6			

STANDARD NO. 209 (2 OF 2)

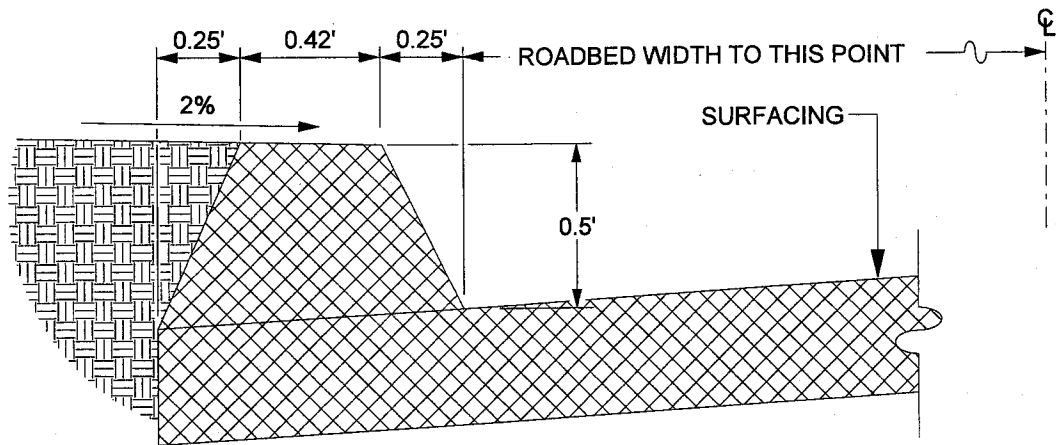

6" A.C. DIKE

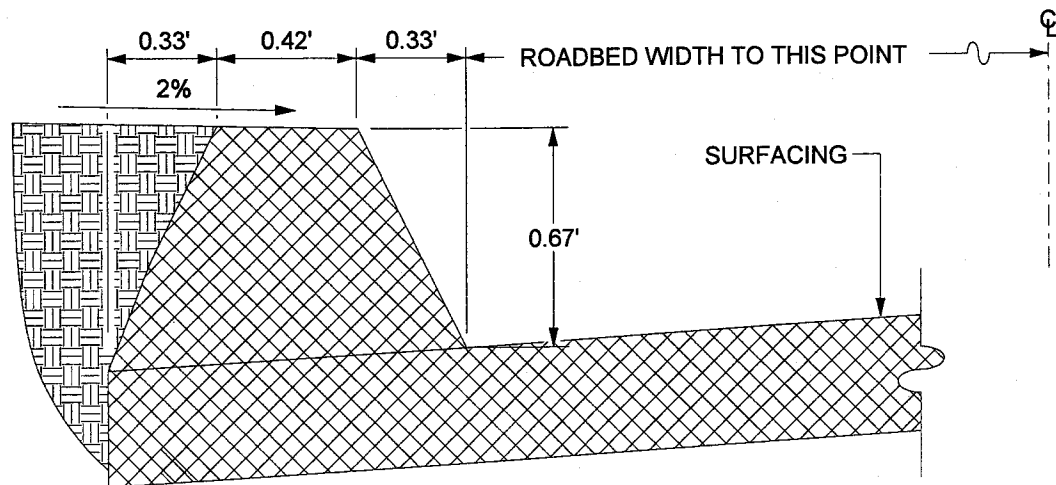

8" A.C. DIKE

NOT TO SCALE

NOTE: A.C. DIKE REQUIRED WHERE FILL SLOPES ARE STEEPER THAN 4:1, MATERIAL IS SUSCEPTIBLE TO EROSION, OR WHERE ROADWAY GRADIENT EXCEEDS 3%.

APPROVED BY:

George A. Johnson
 DIRECTOR OF TRANSPORTATION
 GEORGE A. JOHNSON, RCE 42328

DATE: 05/01/07

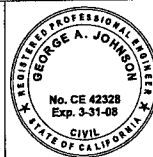

COUNTY OF RIVERSIDE

**ASPHALT CONCRETE
 DIKES**

STANDARD NO. 212

REVISIONS	REV.	BY:	APR'D	DATE	REV.	BY:	APR'D	DATE
	1				4			
	2				5			
	3				6			

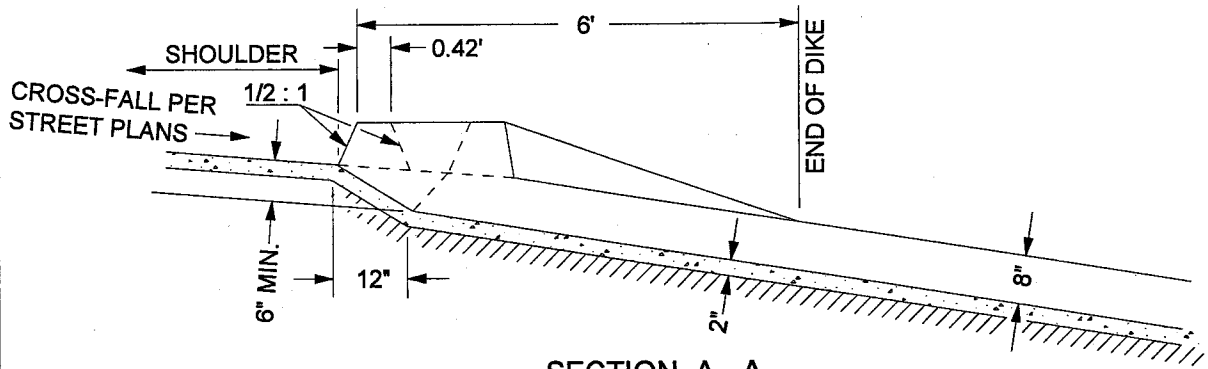

SECTION A - A

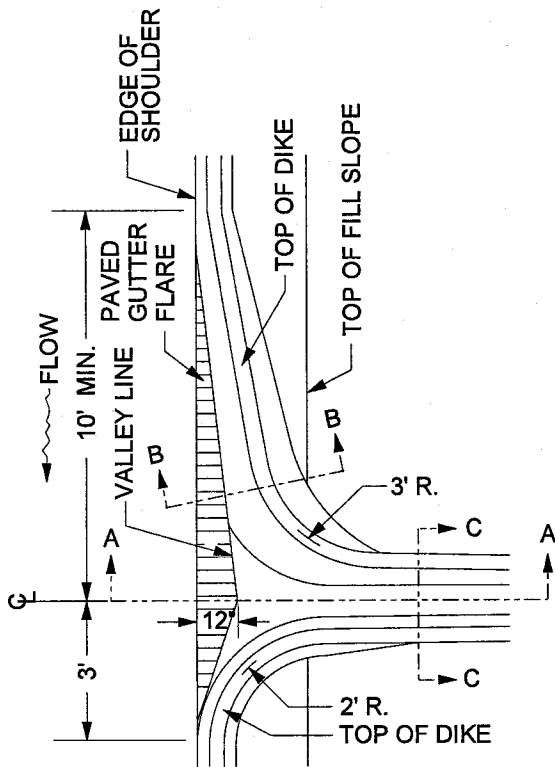

PLAN

NOT TO SCALE

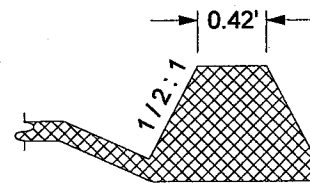

SECTION B - B

NOTE:

CROSS - SECTION OF SLOPE DITCH MAY BE SEMICIRCULAR, VEE, OR TRAPEZOIDAL. MIN. TOP WIDTH = 25", MIN. DEPTH = 8".

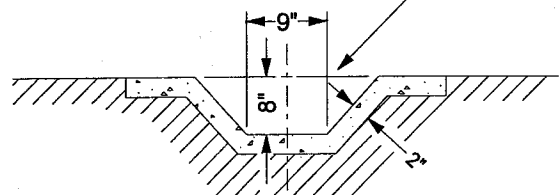

SECTION C - C

TO BE USED ON FILL SLOPES FLATTER THAN 4 : 1. USE MIN. 10' LENGTH OF GUTTER ON BOTH SIDES IN A SAG LOCATION. USE PIPE DOWNDRAINS FOR SLOPES STEEPER THAN 4 : 1 SLOPES.

APPROVED BY:

George A. Johnson
 DIRECTOR OF TRANSPORTATION
 GEORGE A. JOHNSON, RCE 42328

DATE: 05/01/07

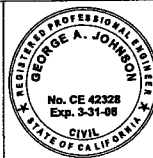

COUNTY OF RIVERSIDE

**ASPHALT CONCRETE
 OVERSIDE DRAIN**

REVISIONS	REV.	BY:	APR'D	DATE	REV.	BY:	APR'D	DATE
8-18-77, 2-82	1				4			
11-04	2				5			
	3				6			

STANDARD NO. 306

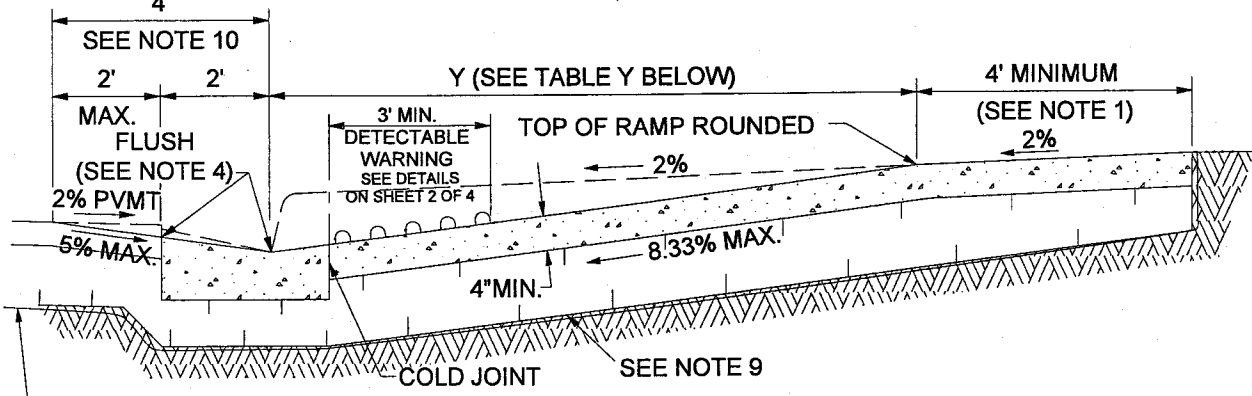
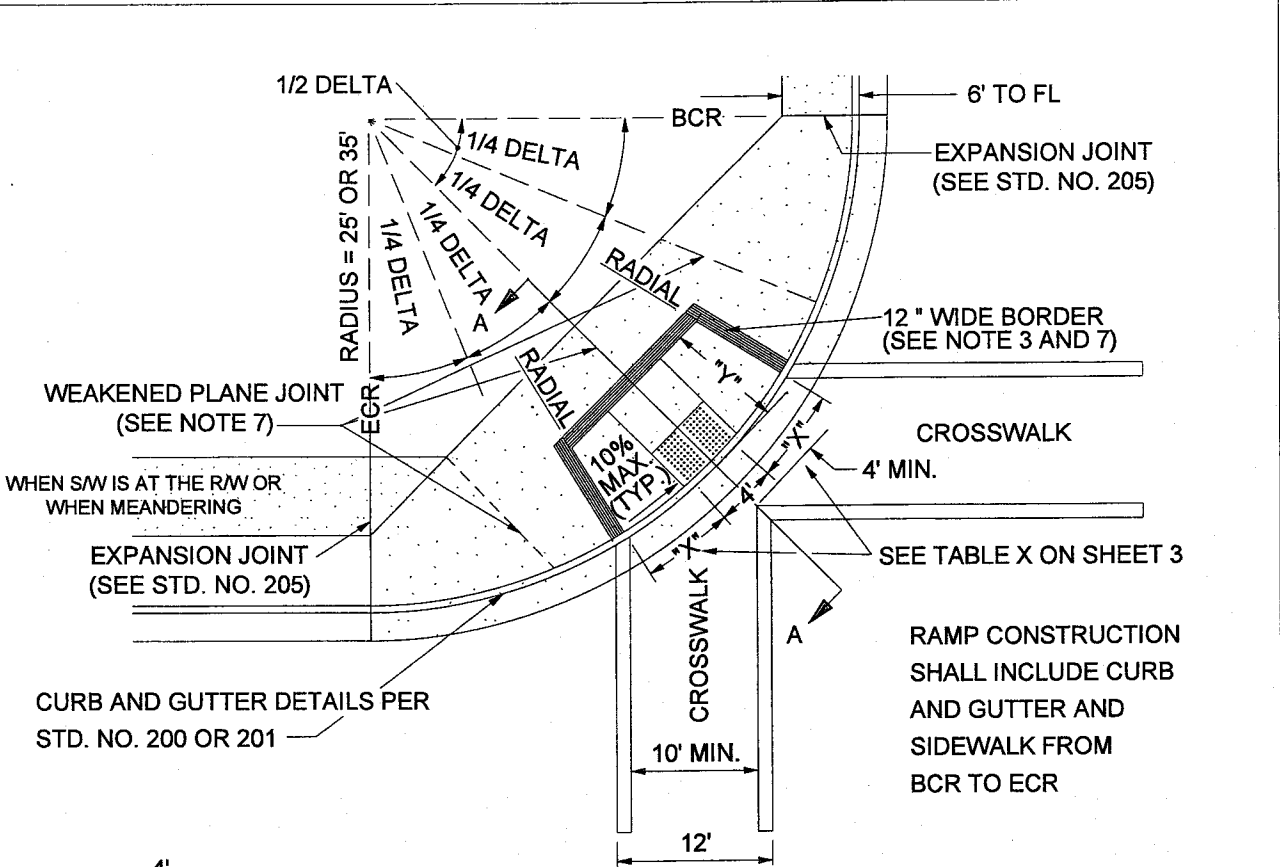

SECTION A-A

TABLE Y

CF	Y
6"	7.90'
8"	10.53'

$$Y = \frac{\text{CURB FACE (FT.)}}{6.33\%}$$

NOT TO SCALE

SEE SHEET 4 OF 4 FOR NOTES.

<p>APPROVED BY:</p> <p><i>George A. Johnson</i> DATE: 11/15/04</p> <p>DIRECTOR OF TRANSPORTATION GEORGE A. JOHNSON, RCE 42328</p>		<p>COUNTY OF RIVERSIDE</p> <p>CURB RAMP CASE A</p>																																							
<table border="1" style="width: 100%; border-collapse: collapse;"> <thead> <tr> <th colspan="2">REVISIONS</th> <th>REV.</th> <th>BY:</th> <th>APR'D</th> <th>DATE</th> <th>REV.</th> <th>BY:</th> <th>APR'D</th> <th>DATE</th> </tr> </thead> <tbody> <tr> <td>8-77, 5-80</td> <td>11-04</td> <td>1</td> <td></td> <td></td> <td></td> <td>4</td> <td></td> <td></td> <td></td> </tr> <tr> <td>10-81, 6-82</td> <td></td> <td>2</td> <td></td> <td></td> <td></td> <td>5</td> <td></td> <td></td> <td></td> </tr> <tr> <td>9-88, 2-90</td> <td></td> <td>3</td> <td></td> <td></td> <td></td> <td>6</td> <td></td> <td></td> <td></td> </tr> </tbody> </table>	REVISIONS		REV.	BY:	APR'D	DATE	REV.	BY:	APR'D	DATE	8-77, 5-80	11-04	1				4				10-81, 6-82		2				5				9-88, 2-90		3				6				<p>STANDARD NO. 403 (1 OF 4)</p>
REVISIONS		REV.	BY:	APR'D	DATE	REV.	BY:	APR'D	DATE																																
8-77, 5-80	11-04	1				4																																			
10-81, 6-82		2				5																																			
9-88, 2-90		3				6																																			

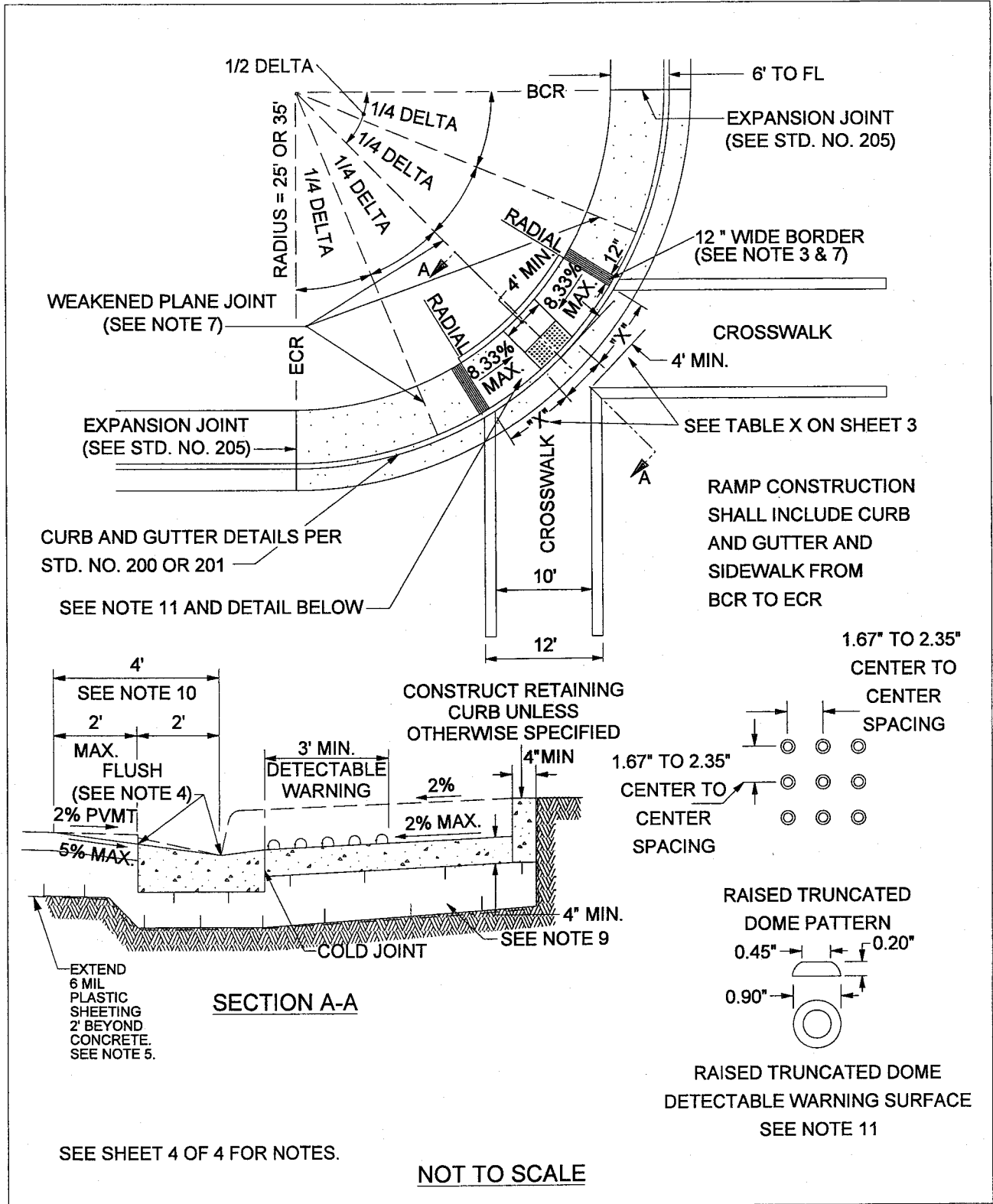

APPROVED BY:

George A. Johnson
 DIRECTOR OF TRANSPORTATION
 GEORGE A. JOHNSON, RCE 42328

DATE: 11/15/04



COUNTY OF RIVERSIDE

**CURB RAMP
 CASE B**

REVISIONS		REV.	BY:	APR'D	DATE	REV.	BY:	APR'D	DATE
8-77, 5-80	11-04	1				4			
10-81, 6-82		2				5			
9-88, 2-90		3				6			

12-97

STANDARD NO. 403 (2 OF 4)

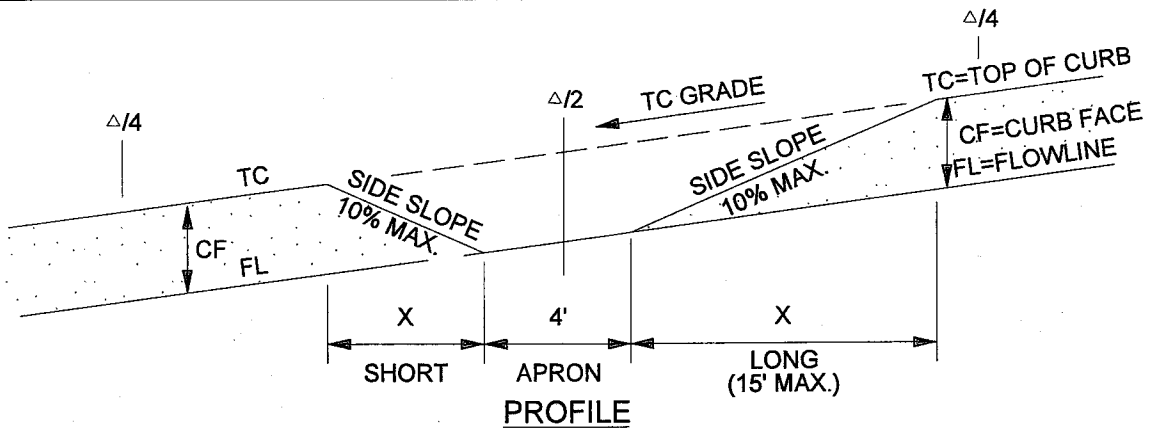

TABLE X

CF (IN)	RADIUS (FT)	SIDE SLOPE	X	TC GRADE (ALONG CURB RETURN)					
				1%	2%	3%	4%	5%	6%
6"	35'	10%	X _S	4.6	4.2	3.9	3.6	3.4	3.2
			X _L	5.6	6.3	7.2	8.4	10.0	12.5
8"	35'	10%	X _S	6.1	5.6	5.2	4.8	4.5	4.2
			X _L	7.5	8.4	9.6	11.2	13.4	15.0

TO CALCULATE "X" DIMENSION:

SHORT SIDE (DOWN SLOPE):

$$X_S (FT) = \frac{\text{CURB FACE (FT)}}{\text{SIDE SLOPE} + \text{TC GRADE}}$$

LONG SIDE (UP SLOPE):

$$X_L (FT) = \frac{\text{CURB FACE (FT)}}{\text{SIDE SLOPE} - \text{TC GRADE}}$$

ENGINEER TO SHOW X_S AND X_L ON IMPROVEMENT PLANS

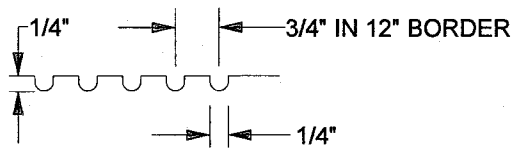

GROOVING DETAIL

APPROVED BY:

George A. Johnson
 DIRECTOR OF TRANSPORTATION
 GEORGE A. JOHNSON, RCE 42328

DATE: 05/05/07

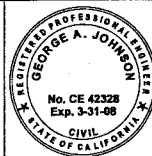

COUNTY OF RIVERSIDE

CURB RAMP

REVISIONS		REV.	BY:	APR'D	DATE	REV.	BY:	APR'D	DATE
8-77, 5-80	11-04	1				4			
10-81, 6-82		2				5			
9-88, 2-90		3				6			

STANDARD NO. 403 (3 OF 4)

CONSTRUCTION NOTES:

1. IF DISTANCE FROM CURB TO BACK OF SIDEWALK IS TOO SHORT TO ACCOMMODATE RAMP AND 4' LANDING, THEN USE THE CASE "B" RAMP.
2. IF SIDEWALK IS LESS THAN 6' WIDE, THE FULL WIDTH OF THE SIDEWALK SHALL BE DEPRESSED AS SHOWN IN CASE B. MINIMUM SIDEWALK WIDTH IS 4' FROM BACK OF CURB.
3. THE RAMP SHALL HAVE A 12" WIDE BORDER WITH GROOVES 1/4" WIDE AND 1/4" DEEP APPROXIMATELY 3/4" ON CENTER. SEE GROOVING DETAIL.
4. TRANSITIONS FROM RAMPS TO WALKS, GUTTERS, OR STREETS SHALL BE FLUSH AND FREE OF ABRUPT CHANGES.
5. WHEN ABUTTING SOIL HAS A HIGH SULFATE CONTENT, SPECIAL CONSIDERATIONS ARE REQUIRED. SEE SPECIFICATIONS (SECTION 16.04).
6. RAMP SIDE SLOPE VARIES UNIFORMLY FROM A MAXIMUM OF UP TO 10% AT CURB TO CONFORM WITH LONGITUDINAL SIDEWALK SLOPE ADJACENT TO TOP OF THE RAMP (EXCEPT IN CASE B).
7. CONSTRUCT WEAKENED PLANE JOINTS AT 1/4 DELTAS WHEN RADIUS EQUALS 35' AND AT INSIDE EDGE OF GROOVED BORDER WHEN RADIUS EQUALS 25'.
8. IF EXPANSIVE SOIL IS ENCOUNTERED, THEN RAMP SHALL BE CONSTRUCTED OVER CLASS 2 AGGREGATE MATERIAL.
9. CONCRETE SHALL BE CLASS B.
10. MAXIMUM SLOPES OF ADJOINING GUTTERS: THE ROAD SURFACE IMMEDIATELY ADJACENT TO THE CURB RAMP AND CONTINUOUS PASSAGE TO THE CURB RAMP SHALL NOT EXCEED 5% WITHIN 4' OF THE BOTTOM OF THE CURB RAMP.
11. DETECTABLE WARNING SURFACES ARE REQUIRED ON ALL CURB RAMPS THAT ENTER INTO A VEHICULAR TRAVEL WAY.

APPROVED BY:

George A. Johnson
 DIRECTOR OF TRANSPORTATION
 GEORGE A. JOHNSON, RCE 42328

DATE: 11/15/04

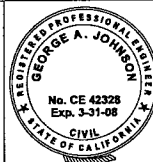

COUNTY OF RIVERSIDE

**CURB RAMP
 CONSTRUCTION NOTES**

REVISIONS		REV.	BY:	APR'D	DATE	REV.	BY:	APR'D	DATE
8-77, 5-80	11-04	1				4			
10-81, 6-82		2				5			
9-88, 2-90		3				6			

STANDARD NO. 403 (4 OF 4)
 12-97

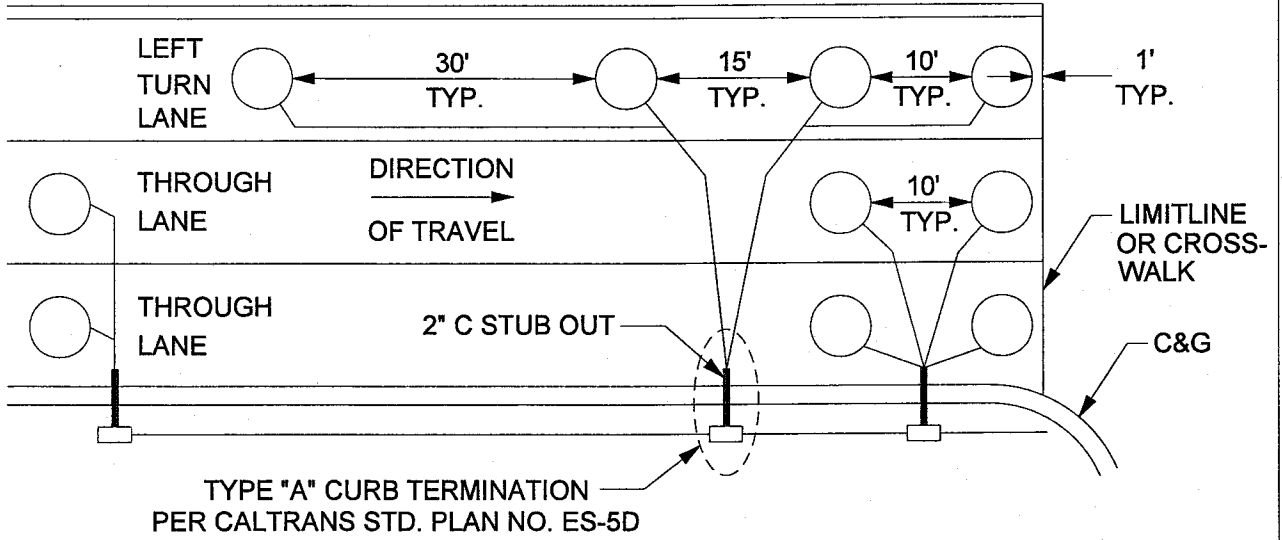

LOOP DETECTOR PLACEMENT DETAIL
NOT TO SCALE

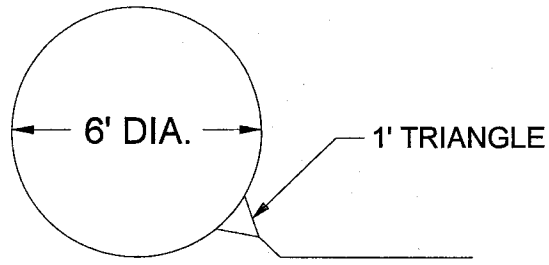

LOOP DETECTOR SAWCUT DETAIL
NOT TO SCALE

**MINIMUM ADVANCED DETECTOR
 SETBACK FROM LIMIT LINE
 (MUTCD 2003 CA SUPPLEMENT)**

SETBACK	SPEED
100'	25
140'	30
185'	35
230'	40
285'	45
345'	50
405'	55
475'	60

APPROVED BY:

George A. Johnson
 DIRECTOR OF TRANSPORTATION
 GEORGE A. JOHNSON, RCE 42328

DATE: 05/01/07

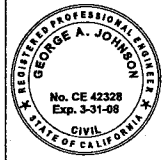

COUNTY OF RIVERSIDE

**TYPE E LOOP DETECTOR
 SAWCUT & PLACEMENT
 DETAIL**

STANDARD NO. 1201

REVISIONS	REV.	BY:	APR'D	DATE	REV.	BY:	APR'D	DATE
	1				4			
	2				5			
	3				6			

2006 STANDARD PLAN A24A

DIST COUNTY ROUTE TOTAL PROJECT NO. SHEETS

REGISTERED CIVIL ENGINEER

May 1, 2006

PLANS APPROVAL DATE

Professional Engineer Seal: Donald E. Hovine, No. C65102, Exp. 3-31-07

To get the software web site, go to <http://www.dot.ca.gov>

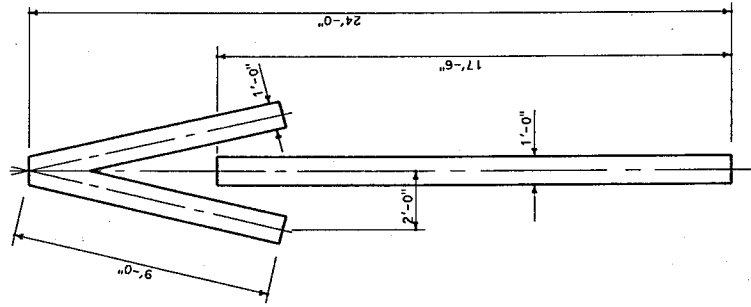

TYPE V ARROW
A=33 sq ft

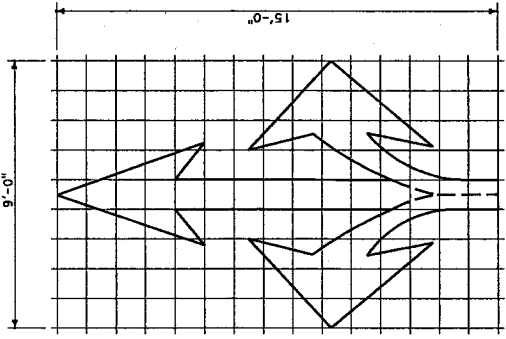

TYPE VIII ARROW
A=36 sq ft

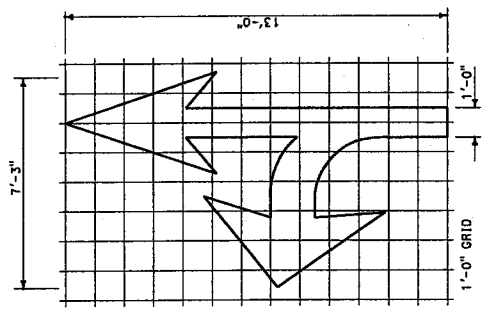

TYPE VII (L) ARROW
A=27 sq ft
(FOR TYPE III (R) ARROW, USE MIRROR IMAGE)

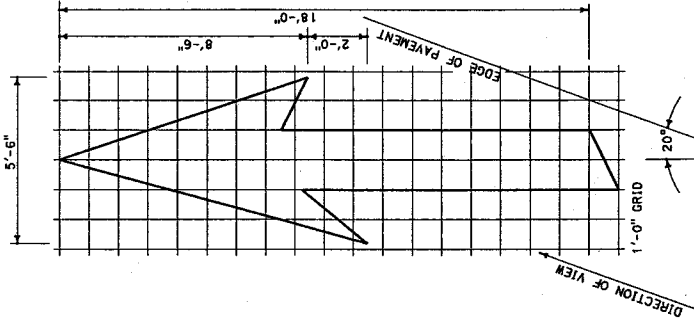

TYPE VI ARROW
A=42 sq ft
RIGHT LANE DROP ARROW
(FOR LEFT LANE, USE MIRROR IMAGE)

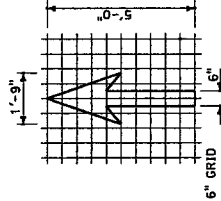

BIKE LANE ARROW
A=7 sq ft

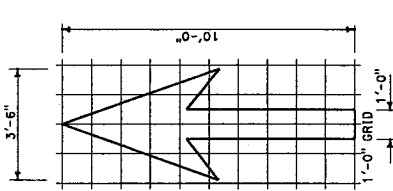

TYPE I 10'-0" ARROW
A=14 sq ft

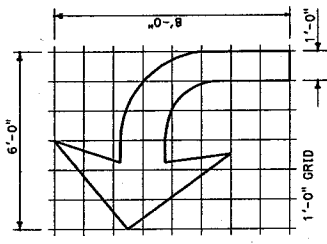

TYPE IV (L) ARROW
A=15 sq ft
(FOR TYPE IV (R) ARROW, USE MIRROR IMAGE)

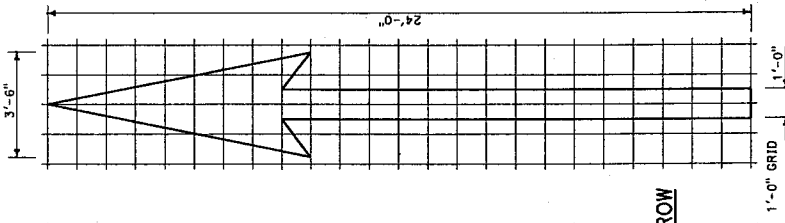

TYPE I 24'-0" ARROW
A=31 sq ft

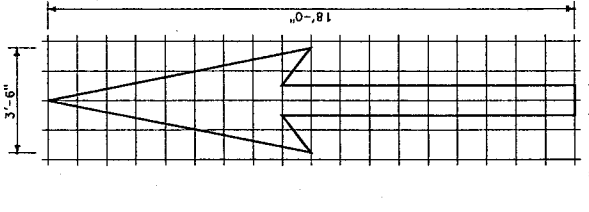

TYPE I 18'-0" ARROW
A=25 sq ft

NOTE:
MINOR VARIATIONS IN DIMENSIONS
MAY BE ACCEPTED BY THE ENGINEER.

STATE OF CALIFORNIA
DEPARTMENT OF TRANSPORTATION
**PAVEMENT MARKINGS
ARROWS**
NO SCALE

A24A

DIST COUNTY ROUTE SHEET NO. PROJECT TOTAL SHEETS

REGISTERED CIVIL ENGINEER
 May 1, 2006
 PLANS APPROVAL DATE
 REGISTERED CIVIL ENGINEER
 PROFESSIONAL ENGINEER
 10080
 No. C16402
 CIVIL
 STATE OF CALIFORNIA
 To get to the California web site, go to <http://www.cesb.org>

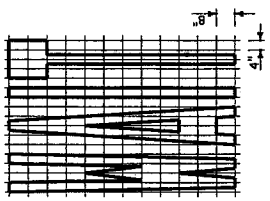

A=19 sq. ft

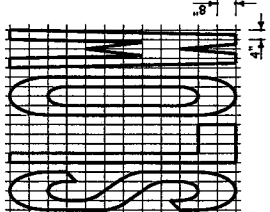

A=23 sq. ft

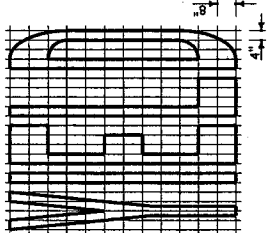

A=24 sq. ft

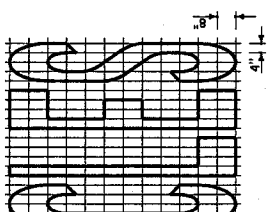

A=42 sq. ft

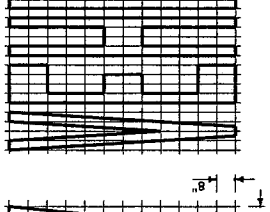

A=31 sq. ft

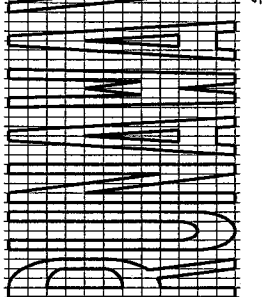

A=43 sq. ft

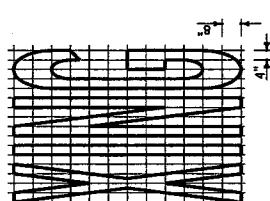

A=21 sq. ft

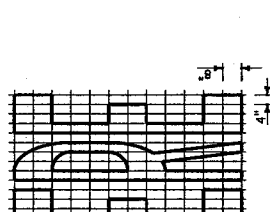

A=26 sq. ft

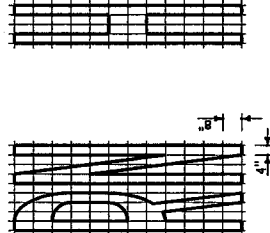

A=24 sq. ft

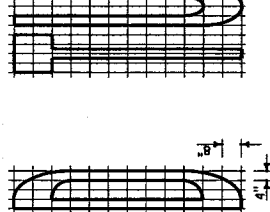

A=31 sq. ft

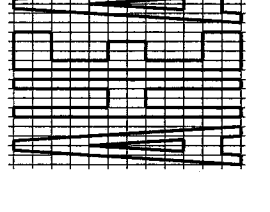

A=35 sq. ft

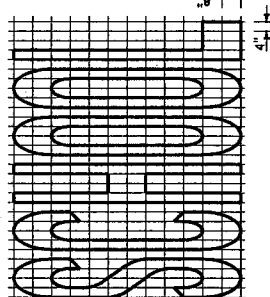

A=10 sq. ft

NOTES:

1. If a message consists of more than one word, it should read "up", i.e., the first word should be nearest the driver.
2. The space between words should be at least four times the height of the characters for low speed roads, but not more than ten times the height of the characters. The space may be reduced appropriately where there is limited space because of local conditions.
3. Minor variations in dimensions may be accepted by the Engineer.
4. Portions of a letter, number or symbol may be separated by connecting segments not to exceed 2" in width.

WORD MARKINGS

ITEM	sq. ft	ITEM	sq. ft	ITEM	sq. ft	ITEM	sq. ft
XING	21	YIELD	24	BIKE	5	PED	18
AHEAD	31	SCHOOL	35	SLOW	23	COMPACT	10
WAIT	19	SIGNAL	32	STOP	22	RUNAWAY	43
LANE	6	TURN	24	LEFT	19	VEHICLES	42
RIGHT	26	HERE	26				

STATE OF CALIFORNIA
 DEPARTMENT OF TRANSPORTATION

PAVEMENT MARKINGS
 WORDS

NO SCALE

A 24D

DIST.	COUNTY	ROUTE	POST MILES	SHEET NO.	TOTAL SHEETS

Michael E. Zinke
REGISTERED CIVIL ENGINEER

PROFESSIONAL ENGINEER
STATE OF CALIFORNIA
NO. 40602
EXPIRES 3-31-07

PLANS APPROVAL DATE: MAY 1, 2006
I, the undersigned, hereby certify that I am a duly licensed Professional Engineer in the State of California and that I am responsible for the accuracy and completeness of the information contained in this plan.
To get to the California web site, go to: <http://www.dca.gov>

WORD MARKINGS			
ITEM	sq. ft.	ITEM sq. ft.	
LANE	24	NO	14
POOL	23	BIKE	21
CLEAR	17	BUS	20
KEEP	24	ONLY	22
		FWY	16

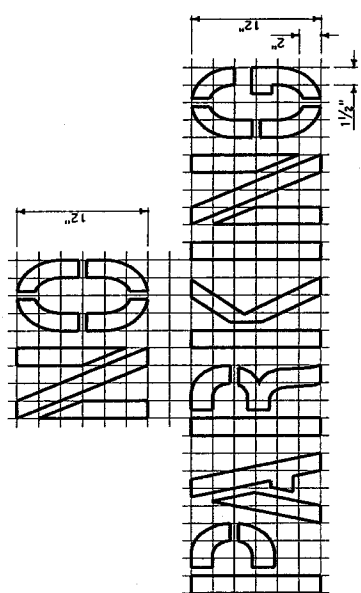
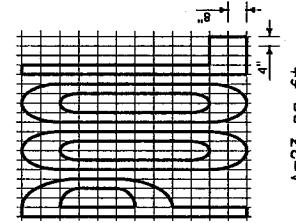
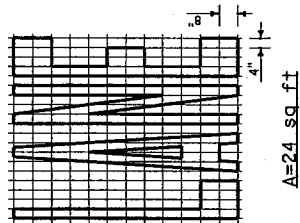
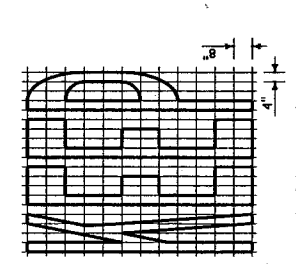
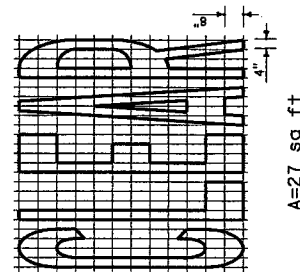
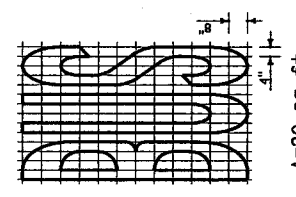
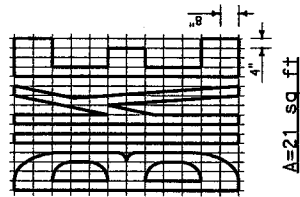
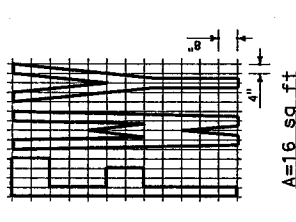
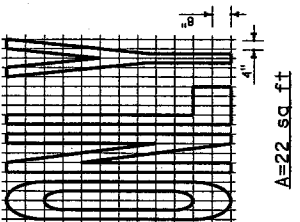
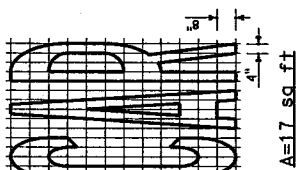
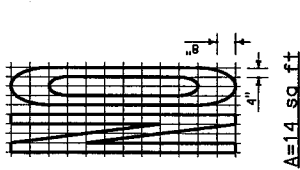

NOTES:

- If a message consists of more than one word, it should read "up", i.e., the first word should be nearest the driver.
- The space between words should be at least four times the height of the characters for low speed roads, but not more than ten times the height of the characters. The space may be reduced appropriately where there is limited space because of local conditions.
- Minor variations in dimensions may be accepted by the Engineer.
- Portions of a letter, number or symbol may be separated by connecting segments not to exceed 2" in width.
- Crosswalks contiguous to school grounds are to be 1'-0" yellow lines in place of 1'-0" white shown.
- The words "NO PARKING" pavement marking is to be used for parking facilities. For typical locations of markings, see Standard Plans A30A and A30B.
- The words "NO PARKING", shall be painted in white letters no less than 1'-0" high on a contrasting background and located so that it is visible to traffic enforcement officials.



CROSSWALK AND LIMIT LINE

See Note 5

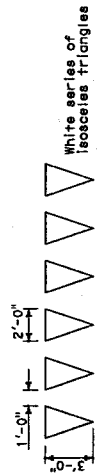

Direction of travel

YIELD LINE

STATE OF CALIFORNIA
DEPARTMENT OF TRANSPORTATION

**PAVEMENT MARKINGS
WORDS AND CROSSWALKS**

NO SCALE

A 24E

DIST.	COUNTY	ROUTE	POST MILES	SHEET TOTALS
			TOTAL PROJECT	NO. SHEETS

REGISTERED PROFESSIONAL ENGINEER Randall D. Hiett REGISTERED CIVIL ENGINEER	
JUNE 6, 2008 PLANS APPROVAL DATE	RANDALL D. HIETT LICENSE NO. 48343 CIVIL

The State of California or the office of the engineer or architect responsible for compliance of electronic works of this plan shall be held harmless.

To accompany plans dated _____

NOTES:

1. When necessary to place dike in front of face of guard railing, only Type C dike may be used. For dike details, see Standard Plan A87B.
2. For standard railing post embedment, see Standard Plans A77C3.
3. Guard railing delineation to be used where shown on the Project Plans.
4. When dike or curb is placed under guard railing, the maximum height of the dike or curb shall be 4". Accountable dike should not be used. For dike and curb details, see Revised Standard Plans RSP A87A and Standard Plan A87B.
5. For details of typical distance between the face of rail and hinge point, see Standard Plan A77C3.

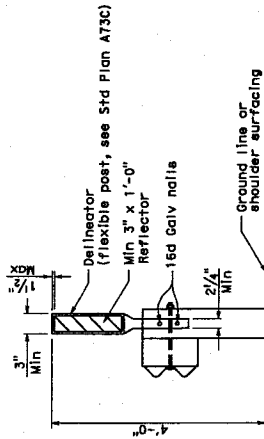

GUARD RAILING DELINEATION
See Note 3

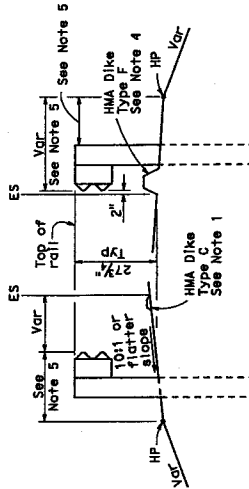

DIKE POSITIONING
See Note 1

STATE OF CALIFORNIA
DEPARTMENT OF TRANSPORTATION

**METAL BEAM GUARD RAILING
TYPICAL RAILING DELINEATION
AND DIKE POSITIONING DETAILS**

NO SCALE

RSP A77C4 DATED JUNE 6, 2008 SUPERSEDES STANDARD PLAN A77C4
DATED MAY 1, 2006 - PAGE 47 OF THE STANDARD PLANS BOOK DATED MAY 2006.

REVISED STANDARD PLAN RSP A77C4

DIST.	COUNTY	ROUTE	POST MILE	SHEET NO.	TOTAL SHEETS

REGISTERED CIVIL ENGINEER
 MAY 1, 2006
 CIVIL ENGINEER
 LICENSE NO. 32507
 REGISTERED PROFESSIONAL ENGINEER
 ALVARADO
 CIVIL ENGINEER
 LICENSE NO. 32507
 REGISTERED PROFESSIONAL ENGINEER

- NOTES:**
1. W = Width of depressed apron. Depressed aprons shall be 4'-0" on shoulder and 4'-0" to 6'-0" in city street gutters unless otherwise shown.
 2. D = Gutter depression. The gutter depression shall be 1/4" for shoulder and 1/4" to 3/8" in city street gutter or locations outside of shoulder unless otherwise shown.
 3. CH = Curb Height.
 4. Details shown for portland cement concrete pavement. When asphalt concrete pavement is used corners to be cut off as shown on detail of Asphalt Concrete Pavement.

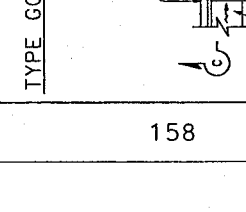
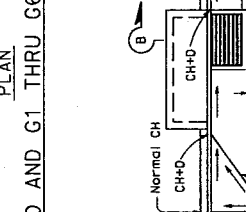
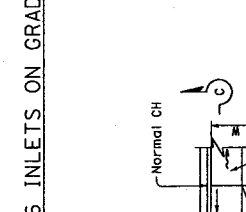
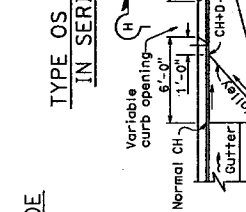
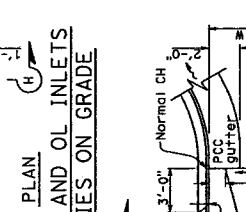
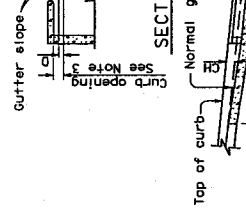
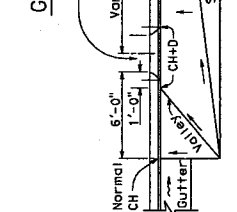
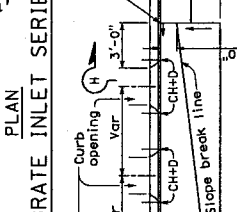
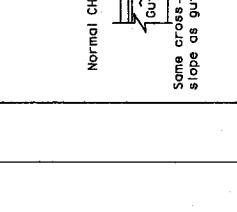
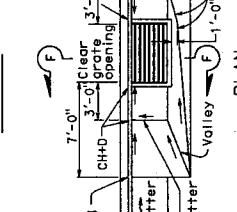
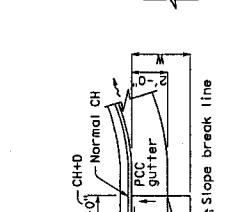
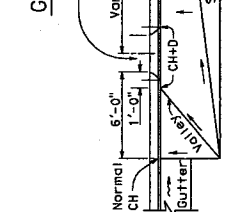
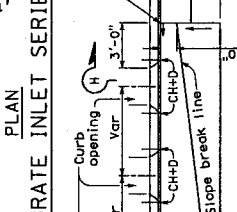
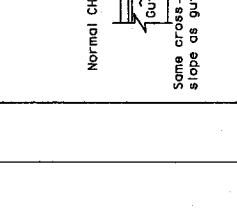
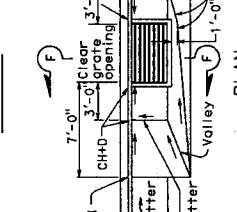
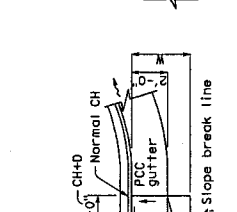
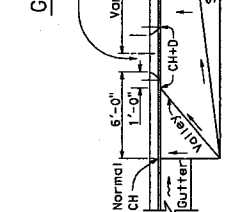
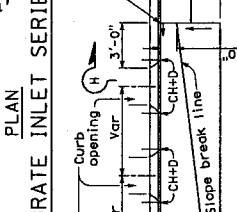
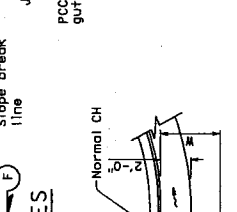
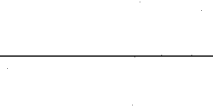
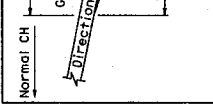
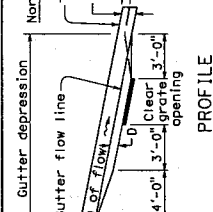
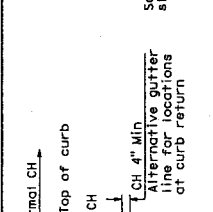
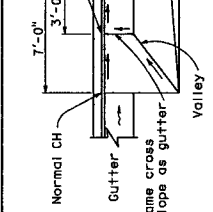
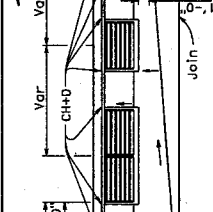
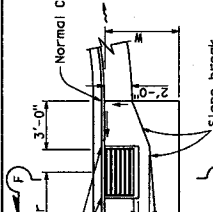

STATE OF CALIFORNIA
 DEPARTMENT OF TRANSPORTATION
GUTTER DEPRESSIONS
 NO SCALE

D78A

PLAN
 TYPE OS AND OL INLETS
 IN GRADE SAG

PLAN
 TYPE G1 THRU G6 GT3 AND GT4
 INLETS IN GRADE SAG

PLAN
 TYPE G0 AND GDO INLET GRADE SAG
 (GDO shown)

DIST.	COUNTY	ROUTE	POST MILES TOTAL PROJECT	SHEET TOTAL SHEETS

REGISTERED ELECTRICAL ENGINEER
Anthony J. McFarland
 License No. 41417
 State of California
 May 1, 2006
 PLANS APPROVAL DATE
 The State of California hereby certifies that the undersigned is a duly licensed and qualified professional engineer for the purpose of electronic design of this plan.

PROJECT: **ES-5B**
 TITLE: **ELECTRICAL SYSTEMS (DETECTORS)**

To get the full California web site, go to: <http://www.ced.org>

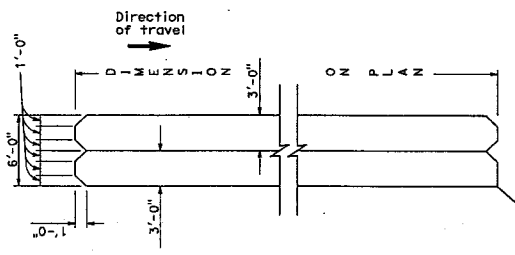

SAWCUT DETAIL
 TYPE C LOOP DETECTOR CONFIGURATION
 WINDING DETAIL

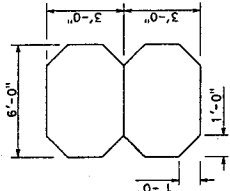

SAWCUT DETAIL
 TYPE Q LOOP DETECTOR CONFIGURATION
 WINDING DETAIL

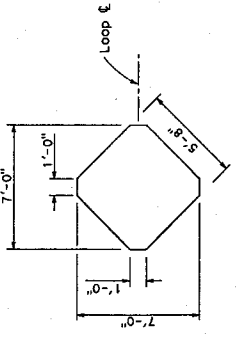

SAWCUT DETAIL
 TYPE B LOOP DETECTOR CONFIGURATION
 WINDING DETAIL

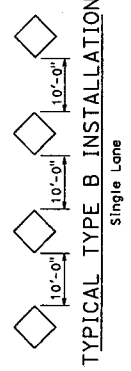
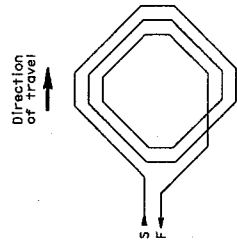

TYPICAL TYPE B INSTALLATION
 Single Lane

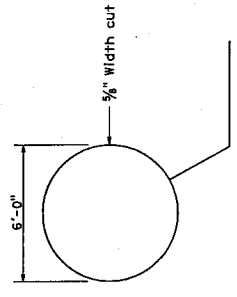

SAWCUT DETAIL
 TYPE E LOOP DETECTOR CONFIGURATION
 WINDING DETAIL

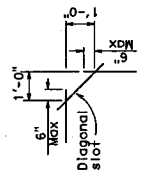
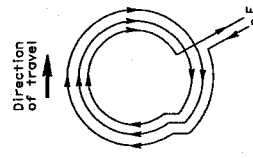

PLAN VIEW OF
 DIAGONAL SLOT
 AT CORNERS

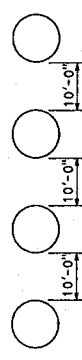

TYPICAL TYPE E INSTALLATION
 Single Lane

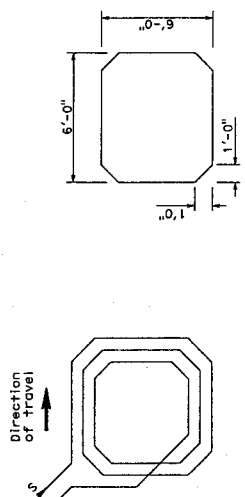

WINDING DETAIL
 TYPE A LOOP DETECTOR CONFIGURATION
 SAWCUT DETAIL

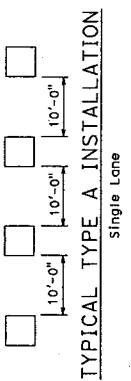

TYPICAL TYPE A INSTALLATION
 Single Lane

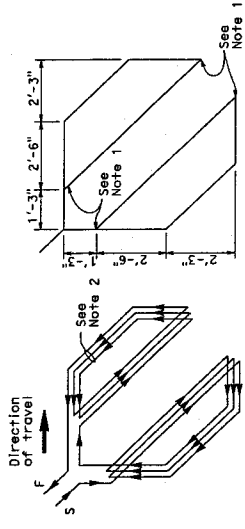

WINDING DETAIL
 TYPE D LOOP DETECTOR CONFIGURATION
 SAWCUT DETAIL

- NOTES:
1. Round corners of acute angle sawcuts to prevent damage to conductors.
 2. Install 3 turns when only one Type D loop is on a sensor unit channel. Install 5 turns when one Type D loop is connected with 3 additional 6'-0" x 5'-0" loops on a sensor unit.

STATE OF CALIFORNIA
 DEPARTMENT OF TRANSPORTATION
**ELECTRICAL SYSTEMS
 (DETECTORS)**

NO SCALE

ES-5B

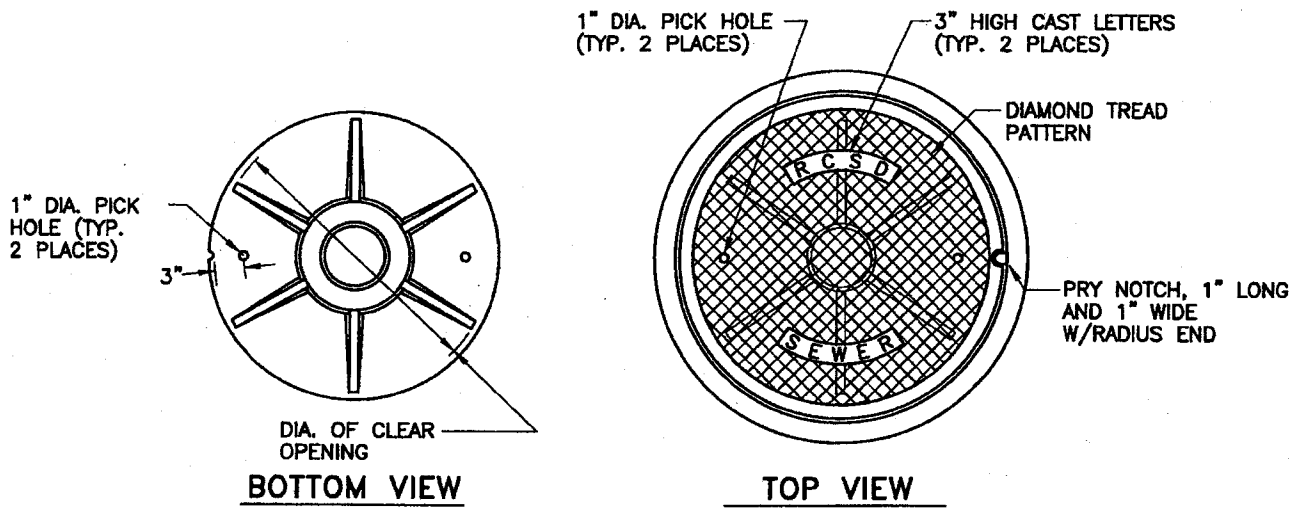

BOTTOM VIEW

TOP VIEW

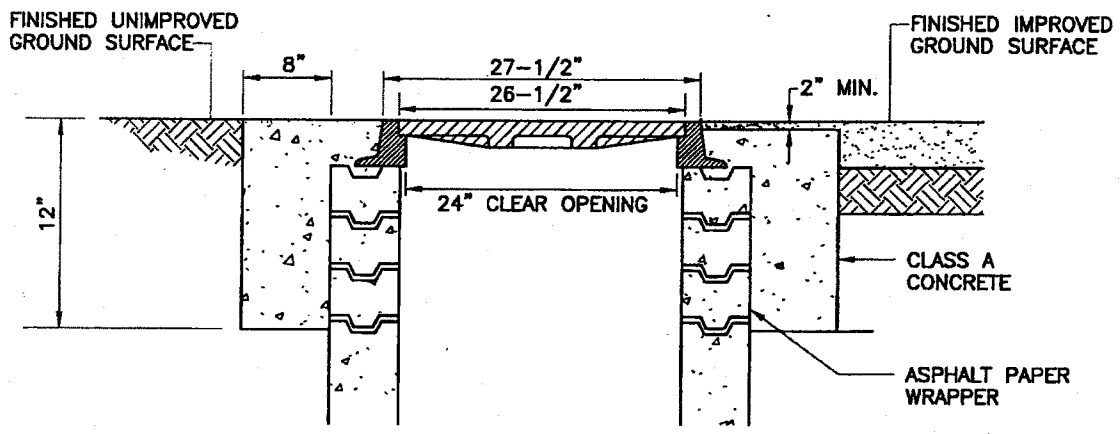

TYPICAL INSTALLATION SECTION

NOTES:

- 1) FRAME AND COVER SHALL BE CAST IRON WITH TENSILE STRENGTH OF 30,000 PSI.
- FOR MANHOLES IN UNIMPROVED LOCATIONS, MANHOLE FRAME AND COVER SHALL BE A WATER PROOF/BOLT DOWN COVER. GASKET MATERIAL SHALL BE 1/2"x1/2" NEOPRENE GASKET. BOLTS SHALL BE A325 (1 1/2" STAINLESS STEEL), SIX EQUALLY SPACED.



APPROVED:
 ASSISTANT GENERAL MANAGER/
 DISTRICT ENGINEER
 DATE: JANUARY 2005

RUBIDOUX COMMUNITY SERVICES DISTRICT
**MANHOLE
 FRAME AND COVER**
 STANDARD DRAWING | S2060



OFFICE OF
CLERK OF THE BOARD OF SUPERVISORS
1st FLOOR, COUNTY ADMINISTRATIVE CENTER
P.O. BOX 1147, 4080 LEMON STREET
RIVERSIDE, CA 92502-1147
PHONE: (951) 955-1060
FAX: (951) 955-1071

KECIA HARPER-IHEM
Clerk of the Board of Supervisors

KIMBERLY A. RECTOR
Assistant Clerk of the Board

December 2, 2010

THE PRESS ENTERPRISE
ATTN: LEGALS
PO BOX 792
RIVERSIDE, CA 92501

FAX (951) 368-9018
E-MAIL: legals@pe.com

**RE: NOTICE INVITING BIDS: RUBIDOUX AREA, MARKET ST., FLEETWOOD DR., VIA CERRO
AND VIA RICARDO – X1107**

To Whom It May Concern:

Attached is a copy for publication in your newspaper for **TEN (10) TIMES:**

Sunday	- December 5, 2010	Friday	- December 10, 2010
Monday	- December 6, 2010	Saturday	- December 11, 2010
Tuesday	- December 7, 2010	Sunday	- December 12, 2010
Wednesday	- December 8, 2010	Monday	- December 13, 2010
Thursday	- December 9, 2010	Tuesday	- December 14, 2010

We require your affidavit of publication immediately upon completion of the last publication.

Your invoice must be submitted to this office in duplicate, WITH TWO CLIPPINGS OF THE PUBLICATION.

**NOTE: PLEASE COMPOSE THIS PUBLICATION INTO A SINGLE COLUMN
FORMAT.**

Thank you in advance for your assistance and expertise.

Sincerely,

Mcgil

Cecilia Gil, Board Assistant to
KECIA HARPER-IHEM, CLERK OF THE BOARD

Gil, Cecilia

From: PE Legals [legals@pe.com]
Sent: Thursday, December 02, 2010 10:19 AM
To: Gil, Cecilia
Subject: RE: FOR PUBLICATION: Rubidoux, Market, Fleetwood - X1107

Hi, yes, sorry we were having some computer issues, but I have it. ☺

Thank You!
Maria

Maria G. Tinajero · Legal Advertising Department · 1-800-880-0345 · Fax: 951-368-9018

enterpris@media

Publisher of the Press-Enterprise

Please Note: Deadline is 10:30 AM two (2) business days prior to the date you would like to publish.
Additional days required for larger ad sizes

From: Gil, Cecilia [mailto:CCGIL@rcbos.org]
Sent: Thursday, December 02, 2010 10:16 AM
To: PE Legals
Subject: FW: FOR PUBLICATION: Rubidoux, Market, Fleetwood - X1107

Hi...did you see this? I don't have confirmation yet (:

Cecilia Gil

Board Assistant to the
Clerk of the Board of Supervisors
951-955-8464

**THE COUNTY ADMINISTRATIVE CENTER IS CLOSED EVERY FRIDAY UNTIL FURTHER NOTICE.
PLEASE CONSIDER THE ENVIRONMENT BEFORE PRINTING.**

From: Gil, Cecilia
Sent: Thursday, December 02, 2010 8:42 AM
To: 'PE Legals'
Subject: FOR PUBLICATION: Rubidoux, Market, Fleetwood - X1107

Again, Notice inviting Bids, for publication from Dec. 5 to Dec. 14, 2010. Please confirm. THANK YOU!

Cecilia Gil

Board Assistant to the
Clerk of the Board of Supervisors
951-955-8464

**THE COUNTY ADMINISTRATIVE CENTER IS CLOSED EVERY FRIDAY UNTIL FURTHER NOTICE.
PLEASE CONSIDER THE ENVIRONMENT BEFORE PRINTING.**



OFFICE OF
CLERK OF THE BOARD OF SUPERVISORS
1st FLOOR, COUNTY ADMINISTRATIVE CENTER
P.O. BOX 1147, 4080 LEMON STREET
RIVERSIDE, CA 92502-1147
PHONE: (951) 955-1060
FAX: (951) 955-1071

KECIA HARPER-IHEM
Clerk of the Board of Supervisors

KIMBERLY A. RECTOR
Assistant Clerk of the Board

December 2, 2010

RIVERSIDE COUNTY RECORD
ATTN: LEGALS
PO BOX 3187
RIVERSIDE, CA 92519

FAX (951) 685-2961
E-MAIL: recordmde@aol.com

**RE: NOTICE INVITING BIDS: RUBIDOUX AREA, MARKET ST., FLEETWOOD DR., VIA CERRO
AND VIA RICARDO – X1107**

To Whom It May Concern:

Attached is a copy for publication in your newspaper for **TWO (2) THURSDAYS:
December 9 and 16, 2010.**

We require your affidavit of publication immediately upon completion of the last publication.

Your invoice must be submitted to this office in duplicate, WITH TWO CLIPPINGS OF THE PUBLICATION.

**NOTE: PLEASE COMPOSE THIS PUBLICATION INTO A SINGLE COLUMN
FORMAT.**

Thank you in advance for your assistance and expertise.

Sincerely,

Mcgil

Cecilia Gil, Board Assistant to
KECIA HARPER-IHEM, CLERK OF THE BOARD

Gil, Cecilia

From: recordmde@aol.com
Sent: Thursday, December 02, 2010 11:42 AM
To: Gil, Cecilia
Subject: Re: FOR PUBLICATION: Rubidoux Area, Market St., Fleetwood - X1107

Hello Cecilia

I have received the notice inviting bids for publication.
Thanks, Mike

-----Original Message-----

From: Gil, Cecilia <CCGIL@rcbos.org>
To: recordmde@aol.com
Sent: Thu, Dec 2, 2010 8:44 am
Subject: FOR PUBLICATION: Rubidoux Area, Market St., Fleetwood - X1107

Hello! Attached is a Notice Inviting Bids, for publication on Dec. 9 and Dec. 16, 2010, Please confirm. THANK YOU!

Cecilia Gil

Board Assistant to the
Clerk of the Board of Supervisors
951-955-8464

**THE COUNTY ADMINISTRATIVE CENTER IS CLOSED EVERY FRIDAY UNTIL FURTHER NOTICE.
PLEASE CONSIDER THE ENVIRONMENT BEFORE PRINTING.**

NOTICE INVITING BIDS

County of Riverside, herein called Owner, invites sealed proposals for:

**RUBIDOUX AREA
ROAD RESURFACING AND RECONSTRUCTION PROJECT
MARKET STREET, FLEETWOOD DRIVE, VIA CERRO, AND VIA RICARDO
PROJECT NO. X1107**

Proposal shall be delivered to the Riverside County Transportation Department, 14th Street Annex, 3525 14th Street, Riverside, California 92501, telephone (951) 955-6780 not later than 2:00 p.m., on Wednesday, December 22, 2010, to be promptly opened in public at said address. Each proposal shall be in accordance with plans, specifications, and other contract documents, dated November 2010, and prepared by County of Riverside, whose address is same as the above, from whom they may be obtained upon deposit of \$35.00 per set plus mailing. No refund. Prospective bidders may preview the plans, specifications and other contract documents, at no charge prior to purchase, at the above noted location.

The Contractor is required to have a Class "A" license or C-12 license at the time of bid submission.

Engineering Estimate:	\$ 2,903,000.00 - \$3,048,000.00
Bid Bond	10%
Performance Bond	100%
Payment Bond	100%
Working Days	60 Calendar Days

www.tlma.co.riverside.ca.us/trans

Dated: December 2, 2010

Kecia Harper-Ihem, Clerk of the Board
By: Cecilia Gil, Board Assistant

⑨ REMITTANCE ADDRESS
 POST OFFICE BOX 12009
 RIVERSIDE, CA 92502-2209
 FAX (951) 368-9026

① BILLING PERIOD
 12/14/10 - 12/14/10
 ⑤ BILLING DATE
 12/14/10
 ② TOTAL AMOUNT DUE
 1,004.30

⑩ ADVERTISING/CLIENT NAME
 BOARD OF SUPERVISORS
 FOR BILLING INFORMATION CALL
 (951) 368-9713
 ④ PAGE NO
 1
 TERMS OF PAYMENT
 Due Upon Receipt

③ BILLED ACCOUNT NAME AND ADDRESS
 BOARD OF SUPERVISORS
 COUNTY OF RIVERSIDE
 P.O. BOX 1147
 RIVERSIDE CA 92502

⑦ BILLED ACCOUNT NUMBER | REP NO
 045202 | LE04

Statement #: 56574600 Amount Paid \$ _____ Your Check # _____

PLEASE DETACH AND RETURN UPPER PORTION WITH YOUR REMITTANCE

① DATE	① REFERENCE	② ③ ④ DESCRIPTION-OTHER COMMENTS/CHARGES	⑤ SAU SIZE ⑥ BILLED UNITS	⑧ RATE	⑩ GROSS AMOUNT	⑫ NET AMOUNT
12/05	4252868 CO	NIB - RUBIDOUX MARKET FLEETWOO Class : 10 Ctext Ad# 10484387 Placed By : Cecilia Gil	83 L	1.30		107.90
12/06	4252868 CO	NIB - RUBIDOUX MARKET FLEETWOO Class : 10 Ctext Ad# 10484387 Placed By : Cecilia Gil	83 L	1.20		99.60
12/07	4252868 CO	NIB - RUBIDOUX MARKET FLEETWOO Class : 10 Ctext Ad# 10484387 Placed By : Cecilia Gil	83 L	1.20		99.60
12/08	4252868 CO	NIB - RUBIDOUX MARKET FLEETWOO Class : 10 Ctext Ad# 10484387 Placed By : Cecilia Gil	83 L	1.20		99.60
12/09	4252868 CO	NIB - RUBIDOUX MARKET FLEETWOO Class : 10 Ctext Ad# 10484387 Placed By : Cecilia Gil	83 L	1.20		99.60
12/10	4252868 CO	NIB - RUBIDOUX MARKET FLEETWOO Class : 10 Ctext Ad# 10484387 Placed By : Cecilia Gil	83 L	1.20		99.60
12/11	4252868 CO	NIB - RUBIDOUX MARKET FLEETWOO Class : 10 Ctext Ad# 10484387 Placed By : Cecilia Gil	83 L	1.20		99.60
12/12	4252868 CO	NIB - RUBIDOUX MARKET FLEETWOO Class : 10 Ctext Ad# 10484387 Placed By : Cecilia Gil	83 L	1.20		99.60
12/13	4252868 CO	NIB - RUBIDOUX MARKET FLEETWOO Class : 10 Ctext Ad# 10484387 Placed By : Cecilia Gil	83 L	1.20		99.60
12/14	4252868 CO	NIB - RUBIDOUX MARKET FLEETWOO Class : 10 Ctext Ad# 10484387 Placed By : Cecilia Gil	83 L	1.20		99.60

*Transp.
3.60 of 11/30/10
1/2*

2010 DEC 20 PM 3:15
 RECEIVED RIVERSIDE COUNTY
 CLERK / BOARD OF SUPERVISORS

④ CURRENT NET AMOUNT DUE	② 30 DAYS	60 DAYS	OVER 90 DAYS	* UNAPPLIED AMOUNT	⑬ PLEASE PAY THIS AMOUNT
					1,004.30

THE PRESS-ENTERPRISE  P.O. BOX 12009
 RIVERSIDE, CA 92502-2209
 TELEPHONE (951) 368-9711
 (951) 368-9720 □ (951) 368-9713

ADVERTISING STATEMENT/INVOICE

* UNAPPLIED AMOUNTS ARE INCLUDED IN TOTAL AMOUNT DUE



⑭ STATEMENT NUMBER	① BILLING PERIOD	⑦ BILLED ACCOUNT NUMBER	⑨ ADVERTISER/CLIENT NUMBER	⑪ ADVERTISER/CLIENT NAME
56574600	12/14/10 - 12/14/10	045202		BOARD OF SUPERVISORS

THE PRESS-ENTERPRISE

3450 Fourteenth Street
Riverside CA 92501-3878
951-684-1200
951-368-9018 FAX

**PROOF OF PUBLICATION
(2010, 2015.5 C.C.P.)**

Press-Enterprise

PROOF OF PUBLICATION OF

Ad Desc.: NIB - Rubidoux Market Fleetwood

I am a citizen of the United States. I am over the age of eighteen years and not a party to or interested in the above entitled matter. I am an authorized representative of THE PRESS-ENTERPRISE, a newspaper of general circulation, printed and published daily in the County of Riverside, and which newspaper has been adjudicated a newspaper of general circulation by the Superior Court of the County of Riverside, State of California, under date of April 25, 1952, Case Number 54446, under date of March 29, 1957, Case Number 65673 and under date of August 25, 1995, Case Number 267864; that the notice, of which the annexed is a printed copy, has been published in said newspaper in accordance with the instructions of the person(s) requesting publication, and not in any supplement thereof on the following dates, to wit:

12-05-10
12-06-10
12-07-10
12-08-10
12-09-10
12-10-10
12-11-10
12-12-10
12-13-10
12-14-10

I Certify (or declare) under penalty of perjury that the foregoing is true and correct.

Date: Dec. 14, 2010
At: Riverside, California

BOARD OF SUPERVISORS

P.O. BOX 1147
COUNTY OF RIVERSIDE
RIVERSIDE CA 92502

Ad #: 10484387

PO #:

Agency #: _____

Ad Copy:

NOTICE INVITING BIDS

County of Riverside, herein called Owner, invites sealed proposals for:

RUBIDOUX AREA ROAD RESURFACING AND RECONSTRUCTION PROJECT MARKET STREET, FLEETWOOD DRIVE, VIA CERRO, AND VIA RICARDO PROJECT NO. X1107

Proposal shall be delivered to the Riverside County Transportation Department, 14th Street Annex, 3525 14th Street, Riverside, California 92501, telephone (951) 955-6780 not later than 2:00 p.m., on Wednesday, December 22, 2010, to be promptly opened in public at said address. Each proposal shall be in accordance with plans, specifications, and other contract documents, dated November 2010, and prepared by County of Riverside, whose address is same as the above, from whom they may be obtained upon deposit of \$35.00 per set plus mailing. No refund. Prospective bidders may preview the plans, specifications and other contract documents, at no charge prior to purchase, at the above noted location.

The Contractor is required to have a Class "A" license or C-12 license at the time of bid submission.

Engineering Estimate: \$ 2,903,000.00 - \$3,048,000.00
Bid Bond 10%
Performance Bond 100%
Payment Bond 100%
Working Days 60 Calendar Days

www.tlma.co.riverside.ca.us/trans

Dated: December 2, 2010

Kecia Harper-Ihern, Clerk of the Board

By: Cecilia Gil, Board Assistant

12/5-14

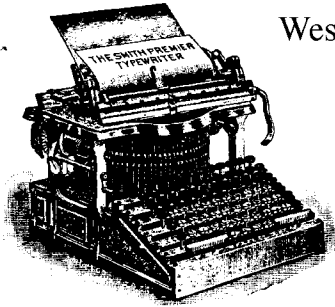

The Riverside County Record Newspaper

Western Riverside County's Only Hometown Newspaper

Since 1955

Post Office Box 3187 • Riverside, California 92519

951 685-6191 • FAX 951 685-2961

e-mail: recorddhh@aol.com

INVOICE

December 8, 2010

Riverside County
Clerk of the Board
4080 Lemon Street, 1st Floor
P.O. Box 1147
Riverside, CA 92502-1147

Legal Advertising

Notice Inviting Bids

Your: Rubidoux Area, X1107
Our #0932

6.50 column inches x \$8.94 = \$58.11 x 2 = \$116.22

Publish two (2) week: December 9, 16, 2010

Amount Due: \$116.22

Thank You,

Cathy Sypin-Barnes

Transp.
3-60 of 11/30/10

RECEIVED RIVERSIDE COUNTY
CLERK / BOARD OF SUPERVISORS
2010 DEC 20 PM 3:17

Affidavit of Publication

(2015.5 C.C.P.)

County of Riverside

State of California

Catherine Sypin-Barnes, being first duly sworn, deposes and says: That at all times hereinafter, mentioned that she was a citizen of the United States, over the age of eighteen years, and a resident of said County, and was at and during all said times the principal clerk of the printer and publisher of The Riverside County Record-News, a newspaper of general circulation, adjudicated by court decree, printed and published weekly in said County of Riverside, State of California, that said Riverside County Record-News is and was at all times herein mentioned, a newspaper of general circulation as that term is defined in section 4460 of the Political Code, and, as provided by that section, is published for the dissemination of local and telegraphic news and intelligence of a general character, having a bona fide subscription list of paying subscribers, and is not devoted to nor published for the interest, entertainment or instruction of a particular class, profession, trade, calling, race or denominations; that at all said time said newspaper has been established, printed and published in said County and State at regular intervals for more than one year preceding the date of publication of the notice hereinafter mentioned; that said notice was set in type not smaller than nonpareil and was preceded with words printed in black face type not smaller than nonpareil describing and expressing in general terms the purport and character of the notice intended to be given; that the

RIVERSIDE COUNTY RECORD NEWSPAPER

of which the annexed is a printed copy, published and printed in said newspaper in at least 2 weekly issues, as follows:

December 9, 16, 2010

I certify (or declare) under penalty of perjury that the foregoing is true and correct.



Signature

Dated: December 16, 2010 at
Riverside, California

NOTICE BY PUBLISHER

County of Riverside, herein called Owner, invites sealed proposals for:
RUBIDOUX AREA

**ROAD RESURFACING AND RECONSTRUCTION PROJECT
MARKET STREET, FLEETWOOD DRIVE, VIA CERRO, AND VIA RICARDO
PROJECT NO. X1107**

Proposal shall be delivered to the Riverside County Transportation Department, 14th Street Annex, 3525 14th Street, Riverside, California 92501, telephone (951) 955-6780 not later than 2:00 p.m., on Wednesday, December 22, 2010, to be promptly opened in public at said address. Each proposal shall be in accordance with plans, specifications, and other contract documents, dated November 22, 2010, and prepared by County of Riverside, whose address is same as the above, from whom they may be obtained upon deposit of \$35.00 per set plus mailing. No refund. Prospective bidders may preview the plans, specifications and other contract documents, at no charge prior to purchase, at the above noted location. The Contractor is required to have a Class "A" license or C-12 license at the time of bid submission.

Engineering Estimate:	\$ 2,903,000.00 - \$3,048,000.00
Bid Bond	10%
Performance Bond	100%
Payment Bond	100%
Working Days	60 Calendar Days

www.tlma.co.riverside.ca.us/trans

Dated: December 2, 2010
By: **Kecia Harper-Thom, Clerk of the Board**
Cecilia Gil, Board Assistant
Published: December 9, 16, 2010 RCR0932