

**SUBMITTAL TO THE BOARD OF SUPERVISORS
COUNTY OF RIVERSIDE, STATE OF CALIFORNIA**

143A



FROM: TLMA - Transportation Department

SUBMITTAL DATE:
December 29, 2010

SUBJECT: Countywide Traffic Signal battery backup system and LED modules improvement project at various locations, Phase 1.

RECOMMENDED MOTION: That the Board of Supervisors:

1. Approve four Addenda to specifications, issued prior to the October 20, 2010 bid opening; and
2. Accept the low bid of Flatiron Electric Group, Inc. of La Mirada, CA in the amount of \$239,685; and

RECOMMENDED MOTION (continued):

Juan C. Perez
Director of Transportation

JCP:jrp:sb
(Continued On Attached Page)

FINANCIAL DATA	Current F.Y. Total Cost:	\$ 239,685	In Current Year Budget:	Yes
	Current F.Y. Net County Cost:	\$ 0	Budget Adjustment:	No
	Annual Net County Cost:	\$ 0	For Fiscal Year:	2010/2011
SOURCE OF FUNDS: Proposition 111 [Gas Tax] (100%)				Positions To Be Deleted Per A-30 <input type="checkbox"/>
				Requires 4/5 Vote <input type="checkbox"/>

C.E.O. RECOMMENDATION:

APPROVE

BY:
Jennifer L. Sargent

County Executive Office Signature

MINUTES OF THE BOARD OF SUPERVISORS

On motion of Supervisor Buster, seconded by Supervisor Benoit and duly carried by unanimous vote, IT WAS ORDERED that the above matter is approved as recommended.

Ayes: Buster, Tavaglione, Stone, Benoit and Ashley
Nays: None
Absent: None
Date: January 11, 2011
xc: Transp.

Kecia Harper-Ihem
Clerk of the Board
By:
Deputy

Prev. Agn. Ref. 9/14/10, Item 3.41 | **District:** All | **Agenda Number:**

3.71

ATTACHMENTS FILED
WITH THE CLERK OF THE BOARD

FORM APPROVED COUNTY COUNSEL
 BY:
 MARSHAL VICTOR
 DATE: 12/21/10
 Departmental Concurrence

Dept't Recomm.: Policy Policy
 Consent Consent
 Per Exec. Ofc.:

The Honorable Board of Supervisors

RE: Countywide Traffic Signal battery backup system and LED modules improvement project at various locations, Phase 1.

December 29, 2010

Page 2 of 2

3. Award the contract to Flatiron Electric Group, Inc. and authorize the Chairman of the Board to execute the contract documents.

BACKGROUND:

By Minute Order dated September 14, 2010 (agenda item 3.41), the Board authorized the Clerk of the Board to advertise for the countywide Traffic Signal battery backup system and LED modules improvement project at various locations, Phase 1. The various locations are listed in Attachment "B". Additionally, the specifications were approved by the Board within this agenda item.

During the advertisement period, four addenda were issued to all registered plan holders as a supplement to the specifications and special provisions. Bidders are required to acknowledge the addenda on their Contractor's Proposal, and are also required to take all addenda into account, to be considered for award. The addenda were issued to clarify and modify the approved contract documents. The addenda are attached as Addendum No. 1, Addendum No. 2, Addendum No. 3, and Addendum No. 4.

Bids for the project were opened in the office of the Director of Transportation at 2:00 PM, Wednesday, October 20, 2010. Eleven bids were received. The basis for the selection of a contractor is the lowest responsive and responsible bid for all schedules of work. The lowest responsive and responsible bid was submitted by Flatiron Electric Group, Inc. of La Mirada, CA, in the amount of \$239,685 which is \$160,730 (40.14%) below the Engineer's Estimate.

The project will be completed within the existing budget shown on Attachment "A".

This project includes replacing and retrofitting existing green and red traffic signal indications with new LED modules and installing battery backup systems throughout Riverside County at various signalized intersections in four phases. There are 47 locations for Phase 1 listed in Attachment "A". Phase 2, 3 and 4 projects are planned for subsequent years. The installation of Battery Backup Systems at these key locations will enhance traffic safety by allowing the signals to keep operating on a battery, or flash red, for a period of time in the event of power interruptions.

The retrofitting of non-LED indications and replacement of old LED indications with more energy efficient LED indications will reduce power consumption and prolong traffic signal operation when operating on battery power.

The Contractor has executed the contract and provided bonds and insurance documents.

The contractor is qualified.

Project No. B9-0996

Form 11 Attachment

Contract/Lease/Purchase Summary Data

Contract (for Services)

- Approval/Renewal
- Sole Source
- Personal Services
- Independent Contractor
- Other than Low Bid
- Change Order

Public Works

Lease

- Approval/Renewal
- Multi-Year Lease
- Equipment
- Real Property
- Change Order

Purchase (for Materials)

- Sole Source
- Other than Low Bid
- Change Order

Selection Committee Member Names (RFPs Only)

User Department:	Transportation Department
-------------------------	----------------------------------

N/A

Vendor/Lessor Name:	Flatiron Electric Group, Inc.
----------------------------	--------------------------------------

Minority

Status: M W DV None

Vendor/Lessor Location:	La Mirada, CA
--------------------------------	----------------------

Local Preference Applied: Yes No N/A

Local Preference Award Cost \$
(5% maximum preference)

Local Preference FYTD: Cost \$ # of Orders

Applicable Board Policy #

Comments:

RFQ/RFP Process:

Date Mailed:
Response Date:
of Responses:
of Qualified Responses:

Bidding Process:

Bid Range: \$ 239,685.00 to \$ 363,287.00
Local Bid Range: N/A
Responsive and Responsible Bid Range: \$ 239,685.00 to \$ 363,287.00

Contract/Lease Renewals Only

Existing Agreement Items

Proposed Agreement Items

1. Rates
2. Terms
3. Conditions
4. Legal Issues
5. Accountability
6. Utilities

(Continue on blank sheet if necessary)

NOTE: COMPETITIVELY BID PUBLIC WORKS CONTRACT

Attachment "A"

Riverside County Transportation Department

Project: **Countywide Traffic Signal battery backup system and LED Module improvement project at various locations, Phase 1**

Project No.(s): **B9-0996**

Project Costs and Budget

Activity	Incurred Costs	Projected Costs	Total Costs	Existing Budget
Preliminary Survey				
Environmental	880	120	1,000	1,000
Design	43,265	735	44,000	37,000
Right-of-way				
Utilities				
Construction		239,685	239,685	400,000
Construction Contingency 10%		23,969	23,969	
Construction Engineering & Inspection 10%	4,800	19,169	23,969	100,000
Construction Survey				
Totals:	48,945	283,677	332,622	538,000

Project Funding

Code	Name	Existing Budget
201	Proposition 111 (Gas Tax)	538,000
Totals		538,000

Comments

COUNTYWIDE TRAFFIC SIGNAL BACKUP SYSTEM AND LED MODULE IMPROVEMENT PROJECT AT VARIOUS LOCATIONS, PHASE 1

ATTACHMENT "B"

NO.	INTERSECTION	SUPERVISOR DISTRICT	CABINET TYPE	BBS INSTALLED EXTERNAL TO EXIST CONTROLLER CABINET	BBS INSTALLED INTERNAL TO EXIST CONTROLLER CABINET	12" RED ARW LED	12" GRN ARW LED	12" RED BALL LED	12" GRN BALL LED	PV RED LED	PV GRN LED
1	LA SIERRA AVE	1	332	EXTERNAL MOUNT	-	2	4	10	9	-	-
2	LA SIERRA AVE	1	332	EXTERNAL MOUNT	-	2	6	11	8	-	-
3	LA SIERRA AVE	1	332	EXTERNAL MOUNT	-	2	6	10	7	-	-
4	LA SIERRA AVE	1	332	EXTERNAL MOUNT	-	3	4	9	9	-	-
5	VAN BUREN BLV	1	333JP	-	-	2	6	12	11	-	-
6	VAN BUREN BLV	1	333JP	-	INTERNAL MOUNT	4	4	12	12	-	-
7	VAN BUREN BLV	1	333JP	-	INTERNAL MOUNT	4	4	10	10	-	-
8	VAN BUREN BLV	1	332	EXTERNAL MOUNT	-	4	10	13	11	-	-
9	VAN BUREN BLV	1	332	EXTERNAL MOUNT	-	8	8	12	12	-	-
10	VAN BUREN BLV	1	332	EXTERNAL MOUNT	-	4	4	12	12	-	-
11	VAN BUREN BLV	1	332	EXTERNAL MOUNT	-	4	4	14	14	-	-
12	ETIWANDA AVE	2	332	EXTERNAL MOUNT	-	4	4	16	16	1	1
13	ETIWANDA AVE	2	332	EXTERNAL MOUNT	-	4	4	14	14	-	-
14	ETIWANDA AVE	2	332	EXTERNAL MOUNT	-	4	4	14	14	-	-
15	ETIWANDA AVE	2	333JP	-	-	8	8	16	16	-	-
16	ETIWANDA AVE	2	333JP	-	INTERNAL MOUNT	4	10	13	11	-	-
17	ETIWANDA AVE	2	332	EXTERNAL MOUNT	-	4	4	14	14	-	-
18	ETIWANDA AVE	2	332	EXTERNAL MOUNT	-	4	4	13	13	-	-
19	ETIWANDA AVE	2	333JP	-	INTERNAL MOUNT	2	2	16	16	2	2
20	ETIWANDA AVE	2	333JP	-	INTERNAL MOUNT	4	6	14	14	2	2
21	MAGNOLIA AVE	2	332	EXTERNAL MOUNT	-	4	4	12	12	-	-
22	MAGNOLIA AVE	2	332	EXTERNAL MOUNT	-	4	4	12	12	-	-
23	MAGNOLIA AVE	2	332	EXTERNAL MOUNT	-	8	8	12	12	-	-
24	MAGNOLIA AVE	2	332	EXTERNAL MOUNT	-	2	4	13	8	2	4
25	MISSION BLV	2	332	EXTERNAL MOUNT	-	-	-	-	-	-	-
26	MISSION BLV	2	332	EXTERNAL MOUNT	-	-	-	-	-	-	-
27	MISSION BLV	2	332	EXTERNAL MOUNT	-	-	-	-	-	-	-
28	MISSION BLV	2	332	EXTERNAL MOUNT	-	-	-	-	-	-	-
29	MISSION BLV	2	332	EXTERNAL MOUNT	-	7	9	10	10	-	-
30	MISSION BLV	2	332	EXTERNAL MOUNT	-	-	-	-	-	-	-
31	MISSION BLV	2	332	EXTERNAL MOUNT	-	5	8	9	8	4	4
32	MISSION BLV	2	332	EXTERNAL MOUNT	-	-	-	-	-	-	-
33	MISSION BLV	2	332	EXTERNAL MOUNT	-	2	2	14	14	2	2
34	DOMENIGONI PKY	3	332	EXTERNAL MOUNT	-	8	8	14	14	-	-
35	DOMENIGONI PKY	3	TYPE P	EXTERNAL MOUNT	-	4	4	16	16	-	-
36	MURRIETA HOT SPRINGS RD	3	332	EXTERNAL MOUNT	-	4	4	16	16	-	-
37	MURRIETA HOT SPRINGS RD	3	332	EXTERNAL MOUNT	-	4	4	16	16	-	-
38	MURRIETA HOT SPRINGS RD	3	332	EXTERNAL MOUNT	-	4	4	16	16	-	-
39	VARNER RD	4	332	EXTERNAL MOUNT	-	8	8	10	10	3	3
40	VARNER RD	4	332	EXTERNAL MOUNT	-	8	8	15	15	-	-
41	WASHINGTON ST	4	332	EXTERNAL MOUNT	-	8	10	12	12	-	-
42	WASHINGTON ST	4	332	EXTERNAL MOUNT	-	3	6	8	6	-	-
43	WASHINGTON ST	4	332	EXTERNAL MOUNT	-	8	10	14	14	-	-
44	CENTER ST	5	332	EXTERNAL MOUNT	-	6	4	10	10	-	-
45	CENTER ST	5	TYPE P	EXTERNAL MOUNT	-	-	-	13	11	-	-
46	RAMONA EKY	5	332	EXTERNAL MOUNT	-	4	4	14	14	-	-
47	RECHE CANYON RD	5	332	EXTERNAL MOUNT	-	-	6	10	7	-	-
TOTAL											
						178	233	521	496	16	18
				39	5						



COUNTY OF RIVERSIDE
TRANSPORTATION AND
LAND MANAGEMENT AGENCY
Transportation Department



Juan C. Perez, P.E., T.E.
Director of Transportation

ADDENDUM NUMBER 1
Dated September 27, 2010

to the
Specifications and Contract Documents
for the construction of

Countywide Traffic Signal Battery Backup system and
LED Modules Improvement Project at various locations, Phase-1
Project No. B9-0996

Bids Due: Wednesday, October 6, 2010; 2:00 PM
14th Street Transportation Annex
3525 14th Street; Riverside, CA 92501
(951) 955-6780

This Addendum is issued pursuant to the Instructions to Bidders, Item No. 8, of the Contract Documents for the reference project. This Addendum is issued as a supplement to the specification and special provisions for the referenced project. The revisions to the specifications shall become a part of the Contract Documents, and each bidder shall acknowledge receipt thereof on the Contractor's Proposal. Bidders are directed to sign this addendum as acknowledged, and attach the signed addendum to the contractor's submitted proposal.

Note: During the advertisement period of this project, this document and attachments (if any) are available upon request at the office of the Transportation Department, and are available as a free download at the Transportation Department's website:
www.tlma.co.riverside.ca.us/trans/con_bid_advertisements.html

MODIFICATIONS / CLARIFICATIONS TO SPECIAL PROVISIONS

Item 1: Liquidated Damages. Refer to page 50, section entitled "Liquidated Damages". Delete the second paragraph and replaced with the following:

"Additionally, the Contractor shall pay to the County of Riverside the sum of \$400.00 per day for each and every calendar day's delay in receiving all of the below listed equipment, onto the job site or at the Contractor's storage facility, and available for installation, within **80** calendar days of the award of the contract by the County of Riverside Board of Supervisors:

1. LED Modules.
2. Battery Backup System.

Contractor shall provide proof of purchase order (PO) and shall furnish the Engineer written statements from vendors stating that they have accepted the order for the said equipment within fifteen (15) calendar days of the date that the County of Riverside Board of Supervisors awarded this contract."

This addendum has been prepared under the direction of the following registered Civil Engineer:



Dowling Tsai, PE
Project Manager



Concurrence:



Khalid Nasim, PE
Engineering Division Manager

Acknowledged: _____ Date: _____
(Contractor)

JRJ:sb



COUNTY OF RIVERSIDE
TRANSPORTATION AND
LAND MANAGEMENT AGENCY
Transportation Department



Juan C. Perez, P.E., T.E.
Director of Transportation

ADDENDUM NUMBER 2

Dated October 5, 2010

to the
Specifications and Contract Documents
for the construction of

Countywide Traffic Signal Battery Backup system and
LED Modules Improvement Project at various locations, Phase-1

Project No. B9-0996

Bids Due: (Revised)
Wednesday, October 13, 2010; 2:00 PM
14th Street Transportation Annex
3525 14th Street; Riverside, CA 92501
(951) 955-6780

This Addendum is issued pursuant to the Instructions to Bidders, Item No. 8, of the Contract Documents for the reference project. This Addendum is issued as a supplement to the specification and special provisions for the referenced project. The revisions to the specifications shall become a part of the Contract Documents, and each bidder shall acknowledge receipt thereof on the Contractor's Proposal. Bidders are directed to sign this addendum as acknowledged, and attach the signed addendum to the contractor's submitted proposal.

Note: During the advertisement period of this project, this document and attachments (if any) are available upon request at the office of the Transportation Department, and are available as a free download at the Transportation Department's website:

www.tlma.co.riverside.ca.us/trans/con_bid_advertisements.html

MODIFICATIONS / CLARIFICATIONS TO SPECIAL PROVISIONS

Item 1: The new designated date and time for the receipt and opening of bids is revised as follows:

Wednesday, October 13, 2010; 2:00 PM
14th Street Transportation Annex
3525 14th Street; Riverside, CA 92501
(951) 955-6780

Item 2: Inspection of Site.
Bidding Contractors are reminded to refer to page A2, section 9, "Inspection of Site".

Regarding **Traffic Control System**, Contractor shall conform to Caltrans Standard Plans for Temporary Traffic Control System in order to prepare necessary lane closure plans per the site requirement.

Regarding **AQMD sign requirements**, Contractor is allowed to use moveable/mobile sign(s) from location to another location. Fugitive dust sources may vary even though this project does not anticipate any grading work; nonetheless, Section 5-1.19 "Dust Abatement" requirements apply as needed for this project's scope of work.

Item 3: Clarification of Battery Back-up System.

Refer to section "Battery Back-up System" page 57 through 64. Delete this Special Provision and replace with the following:

BATTERY BACKUP SYSTEM

This special provision establishes the minimum requirements for a battery backup system (BBS) that shall provide power to a traffic signal system in the event of a power failure or interruption.

The BBS shall be designed for outdoor applications, in accordance with the Chapter 1, Section 8 requirements of Transportation Electrical Equipment Specifications (TEES), dated March 12, 2009.

The BBS batteries shall be external to the traffic signal controller cabinet as specified under "External Battery Cabinet Option" herein unless specified otherwise. The supplied external cabinet shall be listed on the current Caltrans pre-qualified product list for the external BBS cabinet. That list is available at the following Caltrans website:

http://www.dot.ca.gov/hq/esc/ttsb/electrical/pdf/External_BBS_Cabinet_Pre-Qualified_List_rev_9-9-09.pdf

The BBS shall have been installed and operational for a period of one year at any signalized intersection in the United States. The supplied BBS shall be listed on the current Caltrans pre-qualified product list for the BBS. That list is available at the following Caltrans website:

<http://www.dot.ca.gov/hq/esc/ttsb/electrical/bbs.htm>

The BBS shall include, but not limited to the following: cabinet, utility line/generator switch, inverter/charger, power transfer relay, a separate manually operated non-electronic bypass switch, batteries, and all necessary hardware, shelving, and interconnect wiring. The following figure shows BBS components interconnecting with each other and the controller cabinet to ensure interchangeability between all BBS manufacturers.

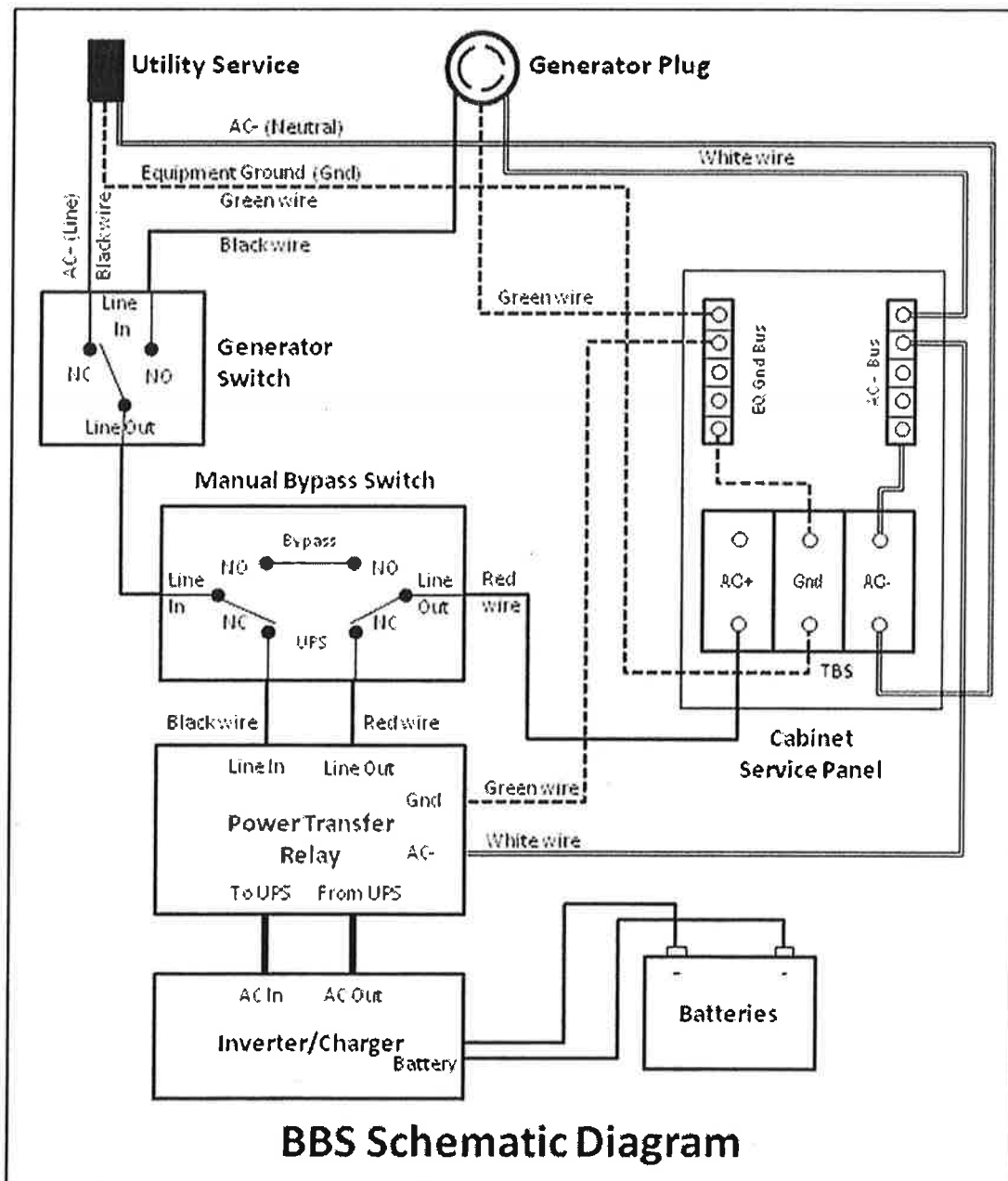

Operation

The BBS shall provide a minimum two (2) hours of full run-time operation for an intersection equipped with all LED traffic signal indications (minimum 1500W/2000VA active output capacity, with 80% minimum inverter efficiency).

The maximum transfer time allowed, from disruption of normal utility line voltage to stabilized inverter line voltage from batteries, shall be 65 milliseconds. The same maximum allowable transfer time shall also apply when switching from inverter line voltage to utility line voltage.

The BBS shall provide the user with 6-sets of fully programmable normally open (NO) and normally closed (NC) single-pole double-throw (SPDT) dry relay contact closures,

available on a panel-mounted terminal block, rated at a minimum 120V/1A, and labeled so as to identify each contact. See below figure for typical configuration.

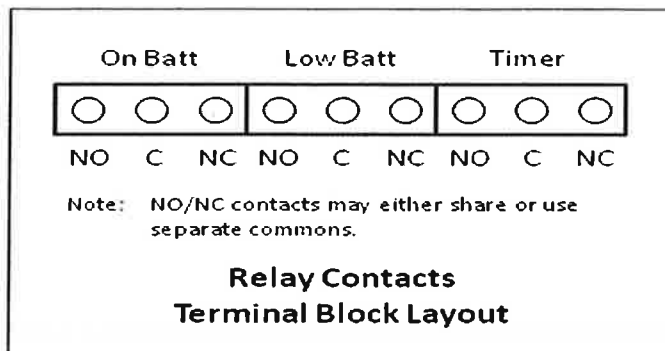

The first set of NO and NC contact closures shall be energized whenever the unit switches to battery power. Contact shall be labeled or marked "On Batt."

The second set of NO and NC contact closures shall be energized whenever the battery approaches approximately 40% of remaining useful capacity. Contact shall be labeled or marked "Low Batt."

The third set of NO and NC contact closures shall be energized two hours after the unit switches to battery power. Contact shall be labeled or marked "Timer".

The six programmable NO and NC contact closures shall be independently configured to activate under any of the following conditions: On Battery, Low Battery, Timer, Alarm, or Fault.

Operating temperature for inverter/charger, power transfer relay and manual bypass switch shall be -37°C to $+74^{\circ}\text{C}$.

Both the Power Transfer Relay and Manual Bypass Switch shall be rated at 240VAC/30 amps, minimum.

The BBS shall use a temperature-compensated battery charging system. The charging system shall compensate over a range of 2.5 – 4.0 mV/ $^{\circ}\text{C}$ per cell.

The temperature sensor shall be external to the inverter/charger unit. The temperature sensor shall come with 10' of wire.

Batteries shall not be recharged when battery temperature exceeds $50^{\circ}\text{C} \pm 3^{\circ}\text{C}$.

BBS shall bypass the utility line power whenever the utility line voltage is outside of the following voltage range: 100VAC to 130VAC ($\pm 2\text{VAC}$).

When utilizing battery power, the BBS output voltage shall be between 110 VAC and 125 VAC, pure sine wave output, $\leq 3\%$ THD, $60\text{Hz} \pm 3\text{Hz}$.

BBS shall be compatible with NEMA and Model 332 Cabinets, Model 170, 390 & 2070 Controllers and cabinet components for full time operation.

In cases of low (below 100VAC) or absent utility line power, when the utility line power

has been restored at above 105 VAC \pm 2 VAC for more than 30 seconds, the BBS shall transfer from battery backed inverter mode back to utility line mode.

In cases of high utility line power (above 130VAC), when the utility line power has been restored at below 125VAC \pm 2 VAC for more than 30 seconds, the BBS shall transfer from battery backed inverter mode back to utility line mode.

The BBS shall have an automatic tap to step up or step down the output voltage by 10 percent. The resulting output voltages shall remain within the above prescribed voltage range: 100VAC to 130VAC. This capability will extend BBS range for operating on input AC and not reverting to battery power.

BBS shall be equipped to prevent a malfunction feedback to the cabinet or from feeding back to the utility service.

In the event of inverter/charger failure, battery failure or complete battery discharge, the power transfer relay shall revert to the NC (and de-energized) state, where utility line power is connected to the cabinet.

Recharge time for the battery, from "protective low-cutoff" to 80% or more of full battery charge capacity, shall not exceed twenty (20) hours.

Mounting / Configuration

Generator Switch, Inverter/Charger, Power Transfer Relay and manually operated Bypass Switch shall fit inside a typical fully equipped traffic signal controller cabinet.

Mounting method inside the 332 cabinet shall be shelf-mount, rack-mount or combination of either. Available rack space for front-mounted inside the 332 cabinet is 3U or approximately 6".

All interconnect wiring provided between Generator Switch, Inverter/Charger, Power Transfer Relay, Bypass Switch and Cabinet Terminal Service Block shall be no less than 9' of UL Style 1015 CSA TEW with the following characteristics:

AWG Rating: 10 AWG
Stranding: 105 strands of 30 AWG tinned copper
Rating: 600 V, 105 °C, PVC Insulation

Relay contact wiring provided for each set of NO/NC relay contact closure terminals shall be 9' of UL Style 1015 CSA TEW 18 AWG wire, same ratings as above, except 16 strands of 30 AWG tinned copper.

All necessary hardware for mounting (shelf angles, rack, etc) shall be included in the bid price of the Traffic and Lighting or BBS.

Internal mounted battery option (Allowed only if requested on the plans)

The controller cabinet shall be equipped with a Hubble generator locking flanged inlet, configuration 6CS6375, 50A, 125VAC and manual transfer switch. The generator inlet

shall be located behind a locking watertight cover. The bypass switch shall transfer the load, including the UPS to the twist lock inlet receptacle. The manual transfer switch shall be wired to prevent any back feed to the utility service.

Batteries shall be mounted on swing-tray mounted below the controller shelf. A minimum of six (6) bolts/fasteners shall be used to secure swing-trays to the 332 Cabinet standard EIA 19" rack. All bolts/fasteners and washers shall meet the following requirements:

Screw type: Pan Head Phillips machine screw Size and Thread pitch: 10-32

Material: 18-8 stainless steel (Type 316 stainless steel is acceptable as an alternate)

Washer: Use one 18-8 stainless steel flat washer under the head 10-32 screw; lock washers are unnecessary provided that the screws are properly tightened.

Number of screws per swivel bracket:

Minimum six (6) screws per swivel bracket. Spaced evenly along bracket, with one screw near each end. Batteries may be shelf mounted in area behind controller so long as shelf and batteries do not interfere with controller unit and C1 plug.

External battery cabinet option

Batteries shall be housed in an external cabinet mounted to the side of the controller cabinet as shown in the following figure or as directed by the Engineer with a minimum of eight bolts:

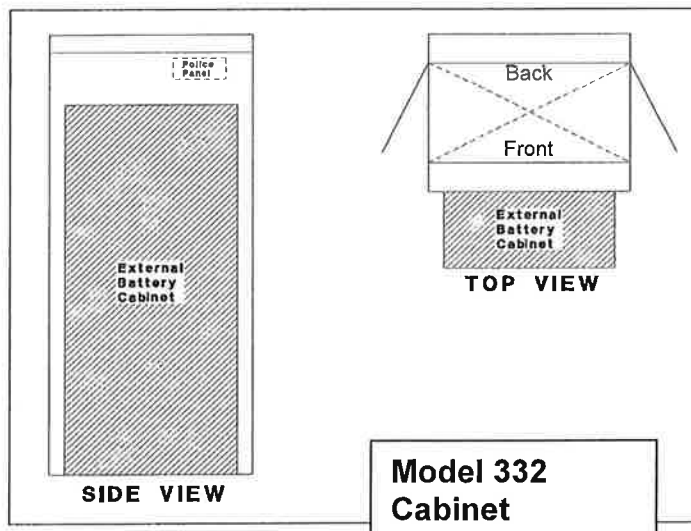

If BBS is installed at the back of controller cabinet, the modification shall include a minimum of 36" wide concrete walkway access to the BBS without encroaching outside the right-of-way. BBS shall be installed at the front of the controller cabinet (in locations where the back of the controller cabinet has limited ROW or conflicting structures and facilities and other obstructions), the BBS cabinet shall not cover the police panel. The BBS cabinet shall also not hinder the access ramp's compliance with ADA requirements.

Four shelves shall be provided within the battery cabinet. There shall be a minimum of 12" clearance between shelves. Each shelf shall be a minimum of 9" X 25", and capable of supporting a minimum of 125 lbs. Batteries shall be mounted on individual shelves.

The external battery cabinet shall be NEMA 3R rated in accordance to Section 2-Housings of the Chapter 7 of TEES, dated March 12, 2009, for the construction of the cabinet and anodic coating finish.

The external battery cabinet shall be ventilated through the use of louvered vents, filter, and one thermostatically controlled fan in accordance to Section 2-Housings of the Chapter 7 of TEES, dated March 12, 2009.

External battery cabinet fan shall be AC operated from the same line output of the Manual Bypass Switch that supplies power to the controller cabinet.

The external battery cabinet shall have a door opening to the entire cabinet. The door shall be attached to the cabinet through the use of either a continuous stainless steel piano hinge or four, two-bolts per leaf, hinges in accordance to Section 2-Housings of the Chapter 7 of TEES, dated March 12, 2009. The door shall use a three-point, roller locking mechanism and standard #2 key lock to lock the door. The door shall have a stainless steel handle.

The external cabinet shall be equipped with a Hubble generator locking flanged inlet, configuration 6CS6375, 50A, 125VAC and manual transfer switch. The generator inlet shall be located behind a locking watertight cover. The bypass switch shall transfer the load, including the UPS to the twist lock inlet receptacle. The manual transfer switch shall be wired to prevent any back feed to the utility service.

The BBS with external battery cabinet shall come with all bolts, conduits and bushings, gaskets, shelves, and hardware needed for mounting.

Maintenance, Displays, Controls And Diagnostics

The BBS shall include a 2 line by 40 character LCD display to indicate current battery charge status, input/output voltages, time and settings of various conditions. The same parameters shall be available via RS232 and USB interfaces on the face of the BBS.

The BBS shall have lightning surge protection compliant with IEEE/ANSI C.62.41.

The BBS shall be capable of accepting firmware upgrades of the non-volatile, read-only memory via serial port communications. The updates shall be accomplished by uploading the software to the BBS over the RS232 serial port located on the face of the BBS.

The BBS shall be equipped with an integral system to prevent battery from destructive discharge and overcharge.

The BBS shall be capable of performing a SELF-TEST, locally from the BBS front panel LCD, or remotely via RS232 or USB interface. The duration of the SELF-TEST shall be programmable in 1-minute increments from 1 minute to 255 minutes.

The BBS and batteries shall be easily replaced with all needed hardware and shall not require any special tools for installation.

The BBS shall include a re-settable inverter event counter to indicate the number of times the BBS was activated and the total number of hours the unit has operated on battery power, accessible via the LCD screen or remotely via RS232 and USB.

The BBS shall be equipped with an event log that stores for a minimum the last 100 events. The events shall be time and date stamped. The event log shall be retrievable via RS232, USB or from the BBS LCD screen. The event log shall be display and print out in plain English when output the RS232 or USB ports.

Battery System

Individual batteries shall be 12V, 105 amp-hour type, and shall be easily replaced and commercially available off the shelf.

Batteries used for BBS shall consist of four (4) batteries with a cumulative minimum rated capacity of 240 amp-hours.

Batteries shall be deep cycle, sealed prismatic lead-calcium based AGM/VRLA (Absorbed Glass Mat/ Valve Regulated Lead Acid).

Batteries shall be certified by the manufacturer to operate over a temperature range of –25 °C to +74 °C.

The batteries shall be provided with appropriate interconnect wiring and corrosion-resistant mounting trays and/or brackets appropriate for the cabinet into which they will be installed.

Batteries shall indicate maximum recharge data and recharging cycles.

Battery Harness

Battery interconnect wiring shall be via two-part modular harness:

Part I shall be equipped with red (+) and black (-) cabling that can be permanently connected to the positive and negative posts of each battery. Each red and black pair shall be terminated into a Molex, polarized – keyed battery cable connector or equivalent. The length of the harness between batteries shall be a minimum of 12”.

Part II shall be equipped with the mating Power Pole style connector for the batteries and a single, insulated Power Pole style connection to the inverter/charger unit. Harness shall be fully insulated and constructed to allow batteries to be quickly and easily connected in any order to ensure proper polarity and circuit configuration. The length of the battery interconnect harness shall be a minimum of 60” from the Inverter/Charger plug to the first battery in the string.

Power Pole connectors may be either one-piece or two-piece. If a two-piece connector is used, a locking pin shall be used to prevent the connectors from separating.

All battery interconnect harness wiring shall be UL Style 1015 CSA TEW or Welding Style Cable or equivalent, all of proper gauge with respect to design current and with sufficient strand count for flexibility and ease of handling.

Battery terminals shall be covered and insulated with molded boots to prevent accidental shorting.

BBS Quality Assurance

Each Battery Backup System (BBS) shall be manufactured in accordance with a manufacturer Quality Assurance (QA) program. The QA program shall include two Quality Assurance procedures:

- (1) Design QA - The manufacturer, or an independent testing lab hired by the manufacturer, shall perform Design Qualification Testing on new BBS system(s) offered, and when any major design change has been implemented on an existing design. A major design change is defined as any modification - material, electrical, physical, or theoretical, that changes any performance characteristics of the system, or results in a different circuit configuration. Where a dispute arises in determining if a system is a new design or if the system has had a major design change, the County will make the final determination if Design Qualification Testing is required prior to production consideration.
- (2) Production QA - The Production QA shall include statistically controlled routine tests to ensure minimum performance levels of BBS units built to meet this specification and a documented process of how problems are to be resolved.

QA process and test results documentation shall be kept on file for a minimum period of seven years.

Battery Backup System designs not satisfying Design QA Testing and Production QA Testing requirements shall not be labeled, advertised, or sold as conforming to this specification.

The Contractor shall arrange to have a technician, qualified to work on the battery backup system and employed by the battery backup system manufacturer or employed by the manufacturers authorized distributor, present at the time the equipment is turned on. It shall be the responsibility of the Contractor to implement and fund any traffic signal controller assembly modifications required to achieve the traffic signal operation as shown on the construction plans and as required in the Special Provisions.

WARRANTY

Manufacturers shall provide a five (5) year warranty. The first three (3) years shall be termed the "Advanced Replacement Program". Under this program, the manufacturer will send out a replacement within two business days of the call notifying them of an issue. The replacement unit may be either a new unit or a re-manufactured unit that is up to the latest revision. The last two years of the warranty will be factory-repair warranty for parts and labor on the BBS.

The contract unit bid prices paid per each for Battery Backup System shall include full compensation for furnishing all labor, tools, materials, equipment and incidentals, and for doing all the work involved to mount BBS externally or internally as specified in these special provisions and as directed by the Engineer, no additional compensation will be allowed therefor.

This addendum has been prepared under the direction of the following registered Civil Engineer:



Dowling Tsai, PE
Project Manager

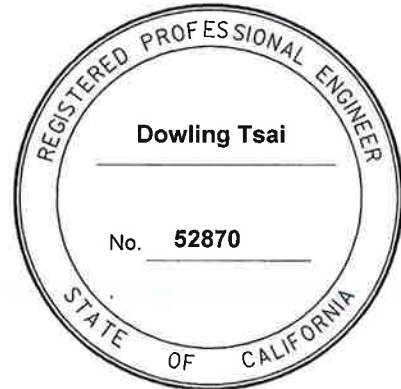

Concurrence:



Khalid Nasim, PE
Engineering Division Manager

Acknowledged: _____ Date: _____
(Contractor)

JRJ:sb



COUNTY OF RIVERSIDE
TRANSPORTATION AND
LAND MANAGEMENT AGENCY
Transportation Department



Juan C. Perez, P.E., T.E.
Director of Transportation

ADDENDUM NUMBER 3
Dated October 7, 2010

to the
Specifications and Contract Documents
for the construction of

Countywide Traffic Signal Battery Backup system and
LED Modules Improvement Project at various locations, Phase-1

Project No. B9-0996

Bids Due: Wednesday, October 13, 2010; 2:00 PM
14th Street Transportation Annex
3525 14th Street; Riverside, CA 92501
(951) 955-6780

This Addendum is issued pursuant to the Instructions to Bidders, Item No. 8, of the Contract Documents for the reference project. This Addendum is issued as a supplement to the specification and special provisions for the referenced project. The revisions to the specifications shall become a part of the Contract Documents, and each bidder shall acknowledge receipt thereof on the Contractor's Proposal. Bidders are directed to sign this addendum as acknowledged, and attach the signed addendum to the contractor's submitted proposal.

Note: During the advertisement period of this project, this document and attachments (if any) are available upon request at the office of the Transportation Department, and are available as a free download at the Transportation Department's website:
www.tlma.co.riverside.ca.us/trans/con_bid_advertisements.html

MODIFICATIONS / CLARIFICATIONS TO SPECIAL PROVISIONS

- Item 1: Clarification of Battery Back-up System.**
Refer to addendum 2; item 3 regarding "Battery Back-up System", page 8 of 10, and subsection entitled "Battery System". Delete second paragraph ("Batteries used....240 amp hours") and replace with the following:

"Batteries used for BBS shall consist of four (4) batteries with a cumulative minimum rated capacity of 420 amp-hours."

This addendum has been prepared under the direction of the following registered Civil Engineer:



Dowling Tsai, PE
Project Manager



Concurrence:



Khalid Nasim, PE
Engineering Division Manager

Acknowledged: _____ Date: _____
(Contractor)

JRJ:sb



COUNTY OF RIVERSIDE
TRANSPORTATION AND
LAND MANAGEMENT AGENCY
Transportation Department



Juan C. Perez, P.E., T.E.
Director of Transportation

ADDENDUM NUMBER 4
Dated October 12, 2010

to the
Specifications and Contract Documents
for the construction of

Countywide Traffic Signal Battery Backup system and
LED Modules Improvement Project at various locations, Phase-1

Project No. B9-0996

Bids Due: (Revised)
Wednesday, October 20, 2010; 2:00 PM
14th Street Transportation Annex
3525 14th Street; Riverside, CA 92501
(951) 955-6780

This Addendum is issued pursuant to the Instructions to Bidders, Item No. 8, of the Contract Documents for the reference project. This Addendum is issued as a supplement to the specification and special provisions for the referenced project. The revisions to the specifications shall become a part of the Contract Documents, and each bidder shall acknowledge receipt thereof on the Contractor's Proposal. Bidders are directed to sign this addendum as acknowledged, and attach the signed addendum to the contractor's submitted proposal.

Note: During the advertisement period of this project, this document and attachments (if any) are available upon request at the office of the Transportation Department, and are available as a free download at the Transportation Department's website:
www.tlma.co.riverside.ca.us/trans/con_bid_advertisements.html

MODIFICATIONS / CLARIFICATIONS TO SPECIAL PROVISIONS

Item 1: The new designated date and time for the receipt and opening of bids is revised as follows:

Wednesday, October 20, 2010; 2:00 PM
14th Street Transportation Annex
3525 14th Street; Riverside, CA 92501
(951) 955-6780

Item 2: Clarification of Battery Back-up System.

Refer to Addendum 2, Item 3, regarding "Battery Back-up System", the following revisions are made in the Special Provisions, and made part hereof:

- A. Refer to Addendum 2, page 3 of 10, subsection entitled "Operation" and delete the first paragraph and replace with the following:

"The BBS shall provide a minimum two (2) hours of full run-time operation for an intersection equipped with all LED traffic signal indications (minimum ~~1500W/2000VA~~ **1100W** active output capacity, with 80% minimum inverter efficiency)."

- B. Refer to Addendum 2, page 7 of 10, subsection entitled "Maintenance, Displays, controls and Diagnostics" and delete the first paragraph and replace with the following:

"The BBS shall include a 2 line by 40 character LCD display to indicate current battery charge status, input/output voltages, time and settings of various conditions. The same parameters shall be available via **RS232 and or USB** interfaces on the face of the BBS."

- C. Refer to Addendum 2, page 8 of 10, delete the first paragraph on this addendum page and replace with the following:

"The BBS shall include a re-settable inverter event counter to indicate the number of times the BBS was activated and the total number of hours the unit has operated on battery power, accessible via the LCD screen or remotely via **RS232 and or USB**."

This addendum has been prepared under the direction of the following registered Civil Engineer:



Dowling Tsai, PE
Project Manager



Concurrence:



Khalid Nasim, PE
Engineering Division Manager

Acknowledged: _____ Date: _____

(Contractor)

JRJ:sb

**Riverside County Transportation Department
Summary of Bids**

**PROJECT: Countywide Traffic Signal Battery Backup System and LED Modules
Improvement Project at various locations, Phase 1**

**Advertised: September 14, 2010 (Agenda Item:3.41)
Addenda: 1 (9/27/10), 2 (10/5/10), 3 (10/7/10), 4 (10/12/10)
Bids Open: 2 pm Date: Wednesday, October 20, 2010**

PROJECT NO. B9-0996

			COUNTY'S ESTIMATE				Flatiron Electric Group, Inc. (Termo) La Mrada, CA. 90638	
ITEM NO.	ITEM CODE	CONTRACT ITEM	UNITS	QUANTITY	UNIT PRICE	ENG ESTIMATE	BID UNIT PRICE	BID ESTIMATE
1	120100	TRAFFIC CONTROL SYSTEM	LS	1	15,000.00	15,000.00	500.00	500.00
2	000003	12" RED ARROW LED TRAFFIC SIGNAL MODULE	EA	178	51.00	9,078.00	51.00	9,078.00
3	000003	12" GREEN ARROW LED TRAFFIC SIGNAL MODULE	EA	233	62.00	14,446.00	58.00	13,514.00
4	000003	12" RED BALL TRAFFIC SIGNAL MODULE	EA	521	55.00	28,655.00	51.00	26,571.00
5	000003	12" GREEN BALL TRAFFIC SIGNAL MODULE	EA	496	79.00	39,184.00	59.00	29,264.00
6	000003	PV RED TRAFFIC SIGNAL MODULE	EA	16	60.00	960.00	104.00	1,664.00
7	000003	PV GREEN TRAFFIC SIGNAL MODULE	EA	18	94.00	1,692.00	118.00	2,124.00
8	731521	MINOR CONCRETE (MAINTENANCE PAD)	SF	220	10.00	2,200.00	9.00	1,980.00
9	000003	BATTERY BACK-UP SYSTEM (MOUNT EXTERNALLY TO CONTROLLER CABINET)	EA	39	6,800.00	265,200.00	3,585.00	139,815.00
10	000003	BATTERY BACK-UP SYSTEM (MOUNT INTERNALLY TO CONTROLLER CABINET)	EA	5	4,800.00	24,000.00	3,035.00	15,175.00
TOTAL						400,415.00		239,685.00
			Republic ITS, Inc. Anaheim, CA 92806				C.T. & F., Inc. Bell Garden, CA 90201	
ITEM NO.	ITEM CODE	CONTRACT ITEM	UNITS	QUANTITY	BID UNIT PRICE	BID ESTIMATE	BID UNIT PRICE	BID ESTIMATE
1	120100	TRAFFIC CONTROL SYSTEM	LS	1	1,500.00	1,500.00	8,002.00	8,002.00
2	000003	12" RED ARROW LED TRAFFIC SIGNAL MODULE	EA	178	48.25	8,588.50	50.72	9,028.16
3	000003	12" GREEN ARROW LED TRAFFIC SIGNAL MODULE	EA	233	55.00	12,815.00	58.95	13,735.35
4	000003	12" RED BALL TRAFFIC SIGNAL MODULE	EA	521	49.00	25,529.00	52.88	27,550.48
5	000003	12" GREEN BALL TRAFFIC SIGNAL MODULE	EA	496	57.00	28,272.00	61.16	30,335.36
6	000003	PV RED TRAFFIC SIGNAL MODULE	EA	16	64.00	1,024.00	54.74	875.84
7	000003	PV GREEN TRAFFIC SIGNAL MODULE	EA	18	79.00	1,422.00	73.32	1,319.76
8	731521	MINOR CONCRETE (MAINTENANCE PAD)	SF	220	48.00	10,560.00	15.01	3,302.20
9	000003	BATTERY BACK-UP SYSTEM (MOUNT EXTERNALLY TO CONTROLLER CABINET)	EA	39	3,875.00	151,125.00	3,771.78	147,099.42
10	000003	BATTERY BACK-UP SYSTEM (MOUNT INTERNALLY TO CONTROLLER CABINET)	EA	5	2,800.00	14,000.00	3,201.42	16,007.10
TOTAL						254,835.50		257,255.67

**Riverside County Transportation Department
Summary of Bids**

**PROJECT: Countywide Traffic Signal Battery Backup System and LED Modules
Improvement Project at various locations, Phase 1**

**Advertised: September 14, 2010 (Agenda Item:3.41)
Addenda: 1 (9/27/10), 2 (10/5/10), 3 (10/7/10), 4 (10/12/10)
Bids Open: 2 pm Date: Wednesday, October 20, 2010**

PROJECT NO. B9-0996

		Macadee Electrical Construction, Inc. Chino, CA 91710			PTM General Engineering, Inc. Riverside, CA 92504			
ITEM NO.	ITEM CODE	CONTRACT ITEM	UNITS	QUANTITY	BID UNIT PRICE	BID ESTIMATE	BID UNIT PRICE	BID ESTIMATE
1	120100	TRAFFIC CONTROL SYSTEM	LS	1	6,519.00	6,519.00	5,385.85	5,385.85
2	000003	12" RED ARROW LED TRAFFIC SIGNAL MODULE	EA	178	82.00	14,596.00	60.94	10,847.32
3	000003	12" GREEN ARROW LED TRAFFIC SIGNAL MODULE	EA	233	82.00	19,106.00	69.24	16,132.92
4	000003	12" RED BALL TRAFFIC SIGNAL MODULE	EA	521	84.00	43,764.00	62.13	32,369.73
5	000003	12" GREEN BALL TRAFFIC SIGNAL MODULE	EA	496	84.00	41,664.00	70.42	34,928.32
6	000003	PV RED TRAFFIC SIGNAL MODULE	EA	16	110.00	1,760.00	78.72	1,259.52
7	000003	PV GREEN TRAFFIC SIGNAL MODULE	EA	18	110.00	1,980.00	94.13	1,694.34
8	731521	MINOR CONCRETE (MAINTENANCE PAD)	SF	220	8.00	1,760.00	32.00	7,040.00
9	000003	BATTERY BACK-UP SYSTEM (MOUNT EXTERNALLY TO CONTROLLER CABINET)	EA	39	3,550.00	138,450.00	4,100.00	159,900.00
10	000003	BATTERY BACK-UP SYSTEM (MOUNT INTERNALLY TO CONTROLLER CABINET)	EA	5	2,870.00	14,350.00	3,100.00	15,500.00
TOTAL								
ITEMS 1-10						283,949.00		285,058.00
		Sierra Pacific Electrical Contracting Riverside, CA 92509			Steiny and Company, Inc. Baldwin Park, CA 91706			
ITEM NO.	ITEM CODE	CONTRACT ITEM	UNITS	QUANTITY	BID UNIT PRICE	BID ESTIMATE	BID UNIT PRICE	BID ESTIMATE
1	120100	TRAFFIC CONTROL SYSTEM	LS	1	8,000.00	8,000.00	4,848.00	4,848.00
2	000003	12" RED ARROW LED TRAFFIC SIGNAL MODULE	EA	178	113.05	20,122.90	54.00	9,612.00
3	000003	12" GREEN ARROW LED TRAFFIC SIGNAL MODULE	EA	233	110.45	25,734.85	61.00	14,213.00
4	000003	12" RED BALL TRAFFIC SIGNAL MODULE	EA	521	86.64	45,139.44	55.00	28,655.00
5	000003	12" GREEN BALL TRAFFIC SIGNAL MODULE	EA	496	95.04	47,139.84	63.00	31,248.00
6	000003	PV RED TRAFFIC SIGNAL MODULE	EA	16	544.25	8,708.00	229.00	3,664.00
7	000003	PV GREEN TRAFFIC SIGNAL MODULE	EA	18	508.55	9,153.90	245.00	4,410.00
8	731521	MINOR CONCRETE (MAINTENANCE PAD)	SF	220	10.00	2,200.00	25.00	5,500.00
9	000003	BATTERY BACK-UP SYSTEM (MOUNT EXTERNALLY TO CONTROLLER CABINET)	EA	39	2,837.00	110,643.00	4,400.00	171,600.00
10	000003	BATTERY BACK-UP SYSTEM (MOUNT INTERNALLY TO CONTROLLER CABINET)	EA	5	2,700.00	13,500.00	3,650.00	18,250.00
TOTAL								
ITEMS 1-10						290,341.93		292,000.00

**Riverside County Transportation Department
Summary of Bids**

**PROJECT: Countywide Traffic Signal Battery Backup System and LED Modules
Improvement Project at various locations, Phase 1**

**Advertised: September 14, 2010 (Agenda Item:3.41)
Addenda: 1 (9/27/10), 2 (10/5/10), 3 (10/7/10), 4 (10/12/10)
Bids Open: 2 pm Date: Wednesday, October 20, 2010**

PROJECT NO. B9-0996

ITEM NO.	ITEM CODE	CONTRACT ITEM	UNITS	QUANTITY	VT Electric, Inc. Upland, CA 91786		Econolite Traffic Engineering, Inc. Anaheim, CA 92806	
					BID UNIT PRICE	BID ESTIMATE	BID UNIT PRICE	BID ESTIMATE
1	120100	TRAFFIC CONTROL SYSTEM	LS	1	10,981.00	10,981.00	11,455.00	11,455.00
2	000003	12" RED ARROW LED TRAFFIC SIGNAL MODULE	EA	178	68.00	12,104.00	93.14	16,578.92
3	000003	12" GREEN ARROW LED TRAFFIC SIGNAL MODULE	EA	233	77.00	17,941.00	100.57	23,432.81
4	000003	12" RED BALL TRAFFIC SIGNAL MODULE	EA	521	69.00	35,949.00	93.77	48,854.17
5	000003	12" GREEN BALL TRAFFIC SIGNAL MODULE	EA	496	78.00	38,688.00	101.81	50,497.76
6	000003	PV RED TRAFFIC SIGNAL MODULE	EA	16	105.00	1,680.00	109.84	1,757.44
7	000003	PV GREEN TRAFFIC SIGNAL MODULE	EA	18	124.00	2,232.00	125.04	2,250.72
8	731521	MINOR CONCRETE (MAINTENANCE PAD)	SF	220	9.00	1,980.00	63.50	13,970.00
9	000003	BATTERY BACK-UP SYSTEM (MOUNT EXTERNALLY TO CONTROLLER CABINET)	EA	39	4,820.00	187,980.00	4,188.70	163,359.30
10	000003	BATTERY BACK-UP SYSTEM (MOUNT INTERNALLY TO CONTROLLER CABINET)	EA	5	3,693.00	18,465.00	3,320.88	16,604.40
TOTAL								
ITEMS 1-10						328,000.00		348,760.52
ITEM NO.	ITEM CODE	CONTRACT ITEM	UNITS	QUANTITY	Dynalectric Los Alamitos, CA 90720		JFL Electric Los Angeles, CA 90001	
					BID UNIT PRICE	BID ESTIMATE	BID UNIT PRICE	BID ESTIMATE
1	120100	TRAFFIC CONTROL SYSTEM	LS	1	75,000.00	75,000.00	34,230.00	34,230.00
2	000003	12" RED ARROW LED TRAFFIC SIGNAL MODULE	EA	178	66.00	11,748.00	68.00	12,104.00
3	000003	12" GREEN ARROW LED TRAFFIC SIGNAL MODULE	EA	233	74.00	17,242.00	85.00	19,805.00
4	000003	12" RED BALL TRAFFIC SIGNAL MODULE	EA	521	50.00	26,050.00	78.00	40,638.00
5	000003	12" GREEN BALL TRAFFIC SIGNAL MODULE	EA	496	58.00	28,768.00	86.00	42,656.00
6	000003	PV RED TRAFFIC SIGNAL MODULE	EA	16	84.00	1,344.00	98.00	1,568.00
7	000003	PV GREEN TRAFFIC SIGNAL MODULE	EA	18	100.00	1,800.00	116.00	2,088.00
8	731521	MINOR CONCRETE (MAINTENANCE PAD)	SF	220	16.00	3,520.00	26.00	5,720.00
9	000003	BATTERY BACK-UP SYSTEM (MOUNT EXTERNALLY TO CONTROLLER CABINET)	EA	39	4,420.00	172,380.00	4,757.00	185,523.00
10	000003	BATTERY BACK-UP SYSTEM (MOUNT INTERNALLY TO CONTROLLER CABINET)	EA	5	3,390.00	16,950.00	3,791.00	18,955.00
TOTAL								
ITEMS 1-10						354,802.00		363,287.00

CONTRACTOR'S PROPOSAL

TO: COUNTY OF RIVERSIDE

DATE: 10-18-10

hereafter called "County":

BIDDER: Flatiron Electric Group, Inc.
(hereafter called "Contractor")

THE UNDERSIGNED, Contractor, having carefully examined the site and the Contract Documents for the construction of COUNTYWIDE TRAFFIC SIGNAL BATTERY BACKUP SYSTEM AND LED MODULES IMPROVEMENT PROJECT AT VARIOUS LOCATIONS, PHASE-1, PROJECT NO. B9-0996 hereby proposes to construct the work in accordance with the Contract Documents, including Addenda Nos. 1, 2 + 3 + 4 for the amount stated in this Proposal.

By submitting this Proposal, Contractor agrees with County:

1. That unless withdrawn in person by Contractor or some person authorized in writing by Contractor not by telephone or telegram before the time specified in the Notice Inviting Bids for the public opening of bids, this Proposal constitutes an irrevocable offer for 90 calendar days after that date.
2. County has the right to reject any or all Proposals and to waive any irregularities or informalities contained in a Proposal.
3. To execute the Agreement and deliver the Faithful Performance Bond, Payment Bond and Insurance Certificate with endorsements, which comply with the requirements set forth in the Instructions to Bidders and General Conditions, within ten (10) working days of the date of the Notice of Acceptance of Proposal and Intent to Award as issued by the County of Riverside.
4. That the contract shall be awarded upon a resolution or minute order to that effect duly adopted by the governing body of County; and that execution of the Contract Documents shall constitute a written memorial thereof.
5. To submit to County such information as County may require to determine whether a particular Proposal is the lowest responsible bid submitted.

6. That the accompanying certified or cashier's check or Bid Bond is in an amount not less than 10% of the total bid submitted and constitutes a guarantee that if awarded the contract, Contractor will execute the Agreement and deliver the required bonds within ten (10) days after notice of award. If Contractor fails to execute and deliver said documents, the check or bond is to be charged with the costs of the resultant damages to County, including but not limited to publication costs, the difference in money between the amount bid and the amount in excess of the bid which it costs County to do or cause to be done the work involved, lease and rental costs, additional salaries and overhead, increased interest and costs of funding the project, attorney expense, additional engineering and architectural expense and cost of maintaining or constructing alternate facilities occasioned by the failure to execute and deliver said documents.
7. By signing this proposal the Contractor certifies that the representations made therein are made under penalty of perjury.

**COUNTY WIDE TRAFFIC SIGNAL BATTERY BACKUP SYSTEM
AND LED MODULE IMPROVEMENT PROJECT
AT VARIOUS LOCATIONS, PHASE 1**

PROJECT NO. B9-0996

PROPOSAL

ITEM No.	ITEM CODE	ITEM	UNIT	ESTIMATED QUANTITY	ITEM PRICE (IN FIGURES)	TOTAL (IN FIGURES)
1	120100	TRAFFIC CONTROL SYSTEM	LS	1	500 ⁰⁰	500 ⁰⁰
2	000003	12" RED ARROW LED TRAFFIC SIGNAL MODULE	EA	178	51.00	9,078 ⁰⁰
3	000003	12" GREEN ARROW LED TRAFFIC SIGNAL MODULE	EA	233	58.00	13,514 ⁰⁰
4	000003	12" RED BALL TRAFFIC SIGNAL MODULE	EA	521	51.00	26,571 ⁰⁰
5	000003	12" GREEN BALL TRAFFIC SIGNAL MODULE	EA	496	59.00	29,264 ⁰⁰
6	000003	PV RED TRAFFIC SIGNAL MODULE	EA	16	104.00	1,664 ⁰⁰
7	000003	PV GREEN TRAFFIC SIGNAL MODULE	EA	18	118.00	2,124 ⁰⁰
8	731521	MINOR CONCRETE (MAINTENANCE PAD)	SF	220	9.00	1,980 ⁰⁰
9	000003	BATTERY BACK-UP SYSTEM (MOUNT EXTERNALLY TO CONTROLLER CABINET)	EA	39	8585 ⁰⁰ mc 7,699	134,815 ⁰⁰ 173,261⁰⁰ mc
10	000003	BATTERY BACK-UP SYSTEM (MOUNT INTERNALLY TO CONTROLLER CABINET)	EA	5	mc 4,165 ⁰⁰ 3035 ⁰⁰	20,825 ⁰⁰ 15,175 ⁰⁰

PROJECT TOTAL: ~~Two Hundred Eighty Eight Thousand Seven Hundred Eighty~~ ^{mc} \$ ~~288,281~~ ^{mc}
 ITEMS 1-10 "WORDS" ~~mc One Dollars & 10/100~~ ^{mc} 239,685⁰⁰
 Two Hundred Thirty Nine Thousand Six Hundred Eighty Five Dollars & 00/100

BIDDER DATA:

Name of Bidder Flatiron Electric Group, Inc.

Type of Organization Corporation

Person(s) Authorized to Sign for Bidder Richard Tesoriero
Vice President

Address 15701 Heron Ave
La Mirada, CA 90638 Phone 714/228-9631

Contractor's License 862724
Type & Number A + C-10

Expiration Date 08-31-11

8. **DESIGNATION OF SUBCONTRACTORS:** Contractor submits the following complete list of each subcontractor who will perform work or labor or render service in or about the construction in an amount in excess of 1/2 of 1% of the total bid.

<u>ITEM</u>	<u>SUBCONTRACTOR</u>	<u>ADDRESS</u>	<u>LICENSE NO.</u>
-------------	----------------------	----------------	--------------------

Percent of work to be performed by sub-contractors: %
(Note: 50% of the work required to be performed by general contractor)

IN WITNESS WHEREOF Contractor executed this Proposal as of the date set forth on Page 1 of this proposal.

Flatiron Electric Group, Inc

TITLE Vice President
"Contractor"

AFFIDAVIT FOR CORPORATE CONTRACTOR

Richard Tesoriero

declares as follows:

That he or she is Vice President of Flatiron Electric Group, Inc. a corporation which is the party making the foregoing proposal or bid; that the bid is not made in the interest of, or on behalf of, any undisclosed person, partnership, company, association, organization, or corporation; that the bid is genuine and not collusive or sham; that the bidder has not directly or indirectly induced or solicited any other bidder to put in a false or sham bid, and has not directly or indirectly colluded, conspired, connived, or agreed with any bidder or anyone else to put in a sham bid, or that anyone shall refrain from bidding; that the bidder has not in any manner, directly or indirectly, sought by agreement, communication, or conference with anyone to fix the bid price of the bidder or any other bidder, or to fix any overhead, profit, or cost element of the bid price, or of that of any other bidder, or to secure any advantage against the County of Riverside or anyone interested in the proposed contract; that all statements contained in the bid are true; and, further, that the bidder has not, directly or indirectly, submitted his or her bid price or any breakdown thereof, or the contents thereof, or divulged information or data relative thereto, or paid, and will not pay, any fee to any corporation, partnership, company association, organization, bid depository, or to any member or agent thereof to effectuate a collusive or sham bid.

I declare, under penalty of perjury, that the foregoing is true and correct.

Dated this 18th (day) of October (month),
2010 (year)
at La Mirada, California

Signature of affiant: 

Note: Notarization of signature required

CALIFORNIA ALL-PURPOSE ACKNOWLEDGMENT

State of California

County of Los Angeles

On October 20, 2010 before me, Shawn R. Bradfield, Notary Public
Date Here Insert Name and Title of the Officer (e.g., "Jane Doe, Notary Public")
personally appeared Richard Tesoriero
Name(s) of Signer(s)

who proved to me on the basis of satisfactory evidence to be the person(s) whose name(s) is/are subscribed to the within instrument and acknowledged to me that he/she/they executed the same in his/her/their authorized capacity(ies), and that by his/her/their signature(s) on the instrument the person(s), or the entity upon behalf of which the person(s) acted, executed the instrument.



I certify under PENALTY OF PERJURY under the laws of the State of California that the foregoing paragraph is true and correct.

WITNESS my hand and official seal.

Signature Shawn R. Bradfield
Signature of Notary Public

OPTIONAL

Though the information below is not required by law, it may prove valuable to persons relying on the document and could prevent fraudulent removal and reattachment of this form to another document.

Description of Attached Document

Title or Type of Document: Affidavit for Corporate Contractor

Document Date: October 19, 2010 Number of Pages: _____

Signer(s) Other Than Named Above: None

Capacity(ies) Claimed by Signer(s)

- Signer's Name: Richard Tesoriero
- Individual
 - Corporate Officer – Title(s): Vice President
 - Partner – Limited General
 - Attorney-in-Fact
 - Trustee
 - Guardian or Conservator
 - Other: _____

- Signer's Name: _____
- Individual
 - Corporate Officer – Title(s): _____
 - Partner – Limited General
 - Attorney-in-Fact
 - Trustee
 - Guardian or Conservator
 - Other: _____

Signer Is Representing: Flatiron Electric Group, Inc.

Signer Is Representing: _____

Addendum no. 1
 Countywide Traffic Signal Battery Backup System and
 LED Modules improvements at various locations, Phase-1
 Project No. B9-0996
 September 27, 2010
 Page 2 of 2

This addendum has been prepared under the direction of the following registered Civil Engineer:



 Dowling Tsai, PE
 Project Manager



Concurrence:



 Khalid Nasim, PE
 Engineering Division Manager

Flatiron Electric Group, Inc

Acknowledged:  _____ Date: Oct. 12, 2010
 (Contractor)

JRJ:sb

Addendum no. 2
 Countywide Traffic Signal Battery Backup System and
 LED Modules improvements at various locations, Phase-1
 Project No. B9-0996
 October 5, 2010
 Page 10 of 10

This addendum has been prepared under the direction of the following registered Civil Engineer:



Dowling Tsai, PE
 Project Manager



Concurrence:



Khalid Nasim, PE
 Engineering Division Manager

Flatiron Electric Group, Inc



Acknowledged: _____ Date: Oct. 12, 2010
 (Contractor)

JR.J:sb

Addendum no. 3
Countywide Traffic Signal Battery Backup System and
LED Modules improvements at various locations, Phase-1
Project No. B9-0996
October 7, 2010
Page 2 of 2

This addendum has been prepared under the direction of the following registered Civil Engineer:



Dowling Tsai, PE
Project Manager



Concurrence:

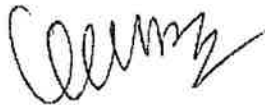

Khalid Nasim, PE
Engineering Division Manager

Flotiron Electric Group, Inc



Acknowledged: _____

(Contractor)

Date: Oct. 12, 2010

JRJ:sb

Addendum no. 4
 Countywide Traffic Signal Battery Backup System and
 LED Modules improvements at various locations, Phase-1
 Project No. B9-0996
 October 12, 2010
 Page 3 of 3

This addendum has been prepared under the direction of the following registered Civil Engineer:



Dowling Tsai, PE
 Project Manager



Concurrence:



Khalid Nasim, PE
 Engineering Division Manager

Flatoron Electric Group, Inc

Acknowledged: _____ Date: 10-20-10
 (Contractor)

JRJ:sb

BID BOND

Recitals:

1. Flatiron Electric Group, Inc. "Contractor", has submitted his Contractor's Proposal to County of Riverside, "County", for the construction of public work for Countywide Traffic Signal Battery Backup System and LED Modules Improvement Project at Various Locations (Phase I) in accordance with a Notice Inviting Bids of County dated September 14, 2010.
2. Travelers Casualty and Surety Company of America a Connecticut corporation, hereafter called "Surety", is the surety of this Bond.

Agreement:

We, Contractor as principal and Surety as surety, jointly and severally agree and state as follows:

1. The amount of the obligation of this bond is 10% of the amount of the Contractor's Proposal, including bid alternates, and inures to the benefit of County.
2. This Bond is exonerated by (1) County rejecting said Proposal or, in the alternate, (2) if said Proposal is accepted, Contractor executes the Agreement and furnishes the Bonds as agreed to in its Proposal, otherwise it remains in full force and effect for the recovery of loss, damage and expense of County resulting from failure of Contractor to act as agreed to in its Proposal. Some types of possible loss, damage and expense are specified in the Contractor's Proposal.
3. Surety, for value received, stipulates and agrees that its obligations hereunder shall in no way be impaired or affected by any extension of time within which County may accept the Proposal and waives notice of any such extension.
4. This Bond is binding on our heirs, executors, administrators, successors and assigns.

Dated: October 19, 2010

Travelers Casualty and Surety Company of America

Flatiron Electric Group, Inc.

By Mary R. McKee

By [Signature]

Title: Attorney in Fact
"Surety"

Title: Vice President
"Contractor"

STATE OF ~~CALIFORNIA~~ New Jersey
COUNTY OF Bergen

} ss. SURETY'S ACKNOWLEDGEMENT

On October 19, 2010 before me, Maria L. Spadaccini personally appeared, Mary R. McKee, known to me, or proved to me on the basis of satisfactory evidence, to be the person whose name is subscribed to the within instrument and acknowledged to me that he/she executed the same in his/her authorized capacities, and that by his/her signature on the instrument the person, or the entity upon behalf of which the person acted, executed the instrument.

WITNESS my hand and official seal.

[Signature]
Signature of Notary Public

MARIA L. SPADACCINI
NOTARY PUBLIC OF NEW JERSEY
COMMISSION EXPIRES
MARCH 6, 2013

Notary Public (Seal)

Note: This Bond must be executed by both parties with corporate seal affixed. All signatures must be notarized

CALIFORNIA ALL-PURPOSE ACKNOWLEDGMENT

State of California

County of Los Angeles

On October 20, 2010 before me, Shawn R. Bradfield, Notary Public
Date Here Insert Name and Title of the Officer (e.g., "Jane Doe, Notary Public")
personally appeared Richard Tesoriero
Name(s) of Signer(s)

who proved to me on the basis of satisfactory evidence to be the person(s) whose name(s) is/are subscribed to the within instrument and acknowledged to me that he/she/they executed the same in his/her/their authorized capacity(ies), and that by his/her/their signature(s) on the instrument the person(s), or the entity upon behalf of which the person(s) acted, executed the instrument.



I certify under PENALTY OF PERJURY under the laws of the State of California that the foregoing paragraph is true and correct.

WITNESS my hand and official seal.

Signature Shawn R. Bradfield
Signature of Notary Public

OPTIONAL

Though the information below is not required by law, it may prove valuable to persons relying on the document and could prevent fraudulent removal and reattachment of this form to another document.

Description of Attached Document

Title or Type of Document: Bid Bond

Document Date: October 19, 2010 Number of Pages: _____

Signer(s) Other Than Named Above: Mary R. McKee, Travelers Casualty and Surety Company

Capacity(ies) Claimed by Signer(s)

- Signer's Name: Richard Tesoriero
- Individual
 - Corporate Officer – Title(s): Vice President
 - Partner – Limited General
 - Attorney-in-Fact
 - Trustee
 - Guardian or Conservator
 - Other: _____

Signer Is Representing: Flatiron Electric Group, Inc.

- Signer's Name: _____
- Individual
 - Corporate Officer – Title(s): _____
 - Partner – Limited General
 - Attorney-in-Fact
 - Trustee
 - Guardian or Conservator
 - Other: _____

Signer Is Representing: _____

CORPORATE ACKNOWLEDGMENT

Form 152

STATE OF NEW JERSEY

COUNTY OF BERGEN

On this 19TH day of OCTOBER, 2010, before me personally came MARY R. MCKEE to me known, who, being by me duly sworn, did depose and say that **she**/he resides SADDLE BROOK, NJ that **she**/he is the ATTORNEY-IN-FACT of TRAVELERS CASUALTY AND SURETY COMPANY OF AMERICA the corporation described in and which executed the above instrument that **she**/he knows the seal of said corporation; that the seal affixed to said instrument is such corporate seal; that it was so affixed by order of the Board of Directors of said corporation, and that **she**/he signed **her**/his name thereto by like order.

(SEAL)



Maria L. Spadaccini, Notary Public

MARIA L. SPADACCINI
NOTARY PUBLIC OF NEW JERSEY
COMMISSION EXPIRES
MARCH 6, 2013

TRAVELERS CASUALTY AND SURETY COMPANY OF AMERICA

HARTFORD, CONNECTICUT 06183

FINANCIAL STATEMENT AS OF DECEMBER 31, 2009

CAPITAL STOCK \$ 6,480,000

ASSETS		LIABILITIES & SURPLUS	
CASH & INVESTED CASH	\$ 91,652,774	UNEARNED PREMIUMS	\$ 856,517,854
BONDS	3,673,398,648	LOSSES	606,279,087
INVESTMENT INCOME DUE AND ACCRUED	51,425,446	LOSS ADJUSTMENT EXPENSES	391,684,336
PREMIUM BALANCES	183,801,016	COMMISSIONS	54,830,598
NET DEFERRED TAX ASSET	72,285,735	TAXES, LICENSES AND FEES	59,474,472
REINSURANCE RECOVERABLE	4,839,080	OTHER EXPENSES	31,730,727
REINSURANCE RECEIVABLE INTERCOMPANY	247,774,291	FUNDS HELD UNDER REINSURANCE TREATIES	101,203,709
OTHER ASSETS	6,728,714	CURRENT FEDERAL AND FOREIGN INCOME TAXES	6,951,413
		REMITTANCES AND ITEMS NOT ALLOCATED	49,208,868
		AMOUNTS WITHHELD / RETAINED BY COMPANY FOR OTHERS	47,770,209
		RETROACTIVE REINSURANCE RESERVE	3,174,786
		POLICYHOLDER DIVIDENDS	8,825,721
		PROVISION FOR REINSURANCE	7,950,803
		CEDED REINSURANCE NET PREMIUMS PAYABLE	(47,612,192)
		PAYABLE TO PARENT, SUBSIDIARIES AND AFFILIATES	60,758,201
		OTHER ACCRUED EXPENSES AND LIABILITIES	1,322,881
		TOTAL LIABILITIES	\$ 2,484,857,039
		CAPITAL STOCK	\$ 6,480,000
		PAID IN SURPLUS	433,803,780
		OTHER SURPLUS	1,356,594,901
		TOTAL SURPLUS TO POLICYHOLDERS	\$ 1,856,648,681
TOTAL ASSETS	\$ 4,331,705,701	TOTAL LIABILITIES & SURPLUS	\$ 4,331,705,701

STATE OF CONNECTICUT)
 COUNTY OF HARTFORD) SS.
 CITY OF HARTFORD)

MICHAEL J. DOODY, BEING DULY SWORN, SAYS THAT HE IS SECOND VICE PRESIDENT, OF TRAVELERS CASUALTY AND SURETY COMPANY OF AMERICA, AND THAT TO THE BEST OF HIS KNOWLEDGE AND BELIEF, THE FOREGOING IS A TRUE AND CORRECT STATEMENT OF THE FINANCIAL CONDITION OF SAID COMPANY AS OF THE 31st DAY OF DECEMBER, 2009.



Michael J. Doody
 SECOND VICE PRESIDENT

 NOTARY PUBLIC -- MY COMMISSION EXPIRES 11/30/2012

SUBSCRIBED AND SWORN TO BEFORE ME THIS
 19th DAY OF APRIL, 2010



POWER OF ATTORNEY

Farmington Casualty Company
Fidelity and Guaranty Insurance Company
Fidelity and Guaranty Insurance Underwriters, Inc.
St. Paul Fire and Marine Insurance Company
St. Paul Guardian Insurance Company

St. Paul Mercury Insurance Company
Travelers Casualty and Surety Company
Travelers Casualty and Surety Company of America
United States Fidelity and Guaranty Company

Attorney-In Fact No. 222859

Certificate No. 003903422

KNOW ALL MEN BY THESE PRESENTS: That St. Paul Fire and Marine Insurance Company, St. Paul Guardian Insurance Company and St. Paul Mercury Insurance Company are corporations duly organized under the laws of the State of Minnesota, that Farmington Casualty Company, Travelers Casualty and Surety Company, and Travelers Casualty and Surety Company of America are corporations duly organized under the laws of the State of Connecticut, that United States Fidelity and Guaranty Company is a corporation duly organized under the laws of the State of Maryland, that Fidelity and Guaranty Insurance Company is a corporation duly organized under the laws of the State of Iowa, and that Fidelity and Guaranty Insurance Underwriters, Inc., is a corporation duly organized under the laws of the State of Wisconsin (herein collectively called the "Companies"), and that the Companies do hereby make, constitute and appoint

Sandra K. Wolf, Alice McLaughlin, Mary R. McKee, Sherryanne M. DePirro, and Maria L. Spadaccini

of the City of Woodcliff Lake, State of New Jersey, their true and lawful Attorney(s)-in-Fact, each in their separate capacity if more than one is named above, to sign, execute, seal and acknowledge any and all bonds, recognizances, conditional undertakings and other writings obligatory in the nature thereof on behalf of the Companies in their business of guaranteeing the fidelity of persons, guaranteeing the performance of contracts and executing or guaranteeing bonds and undertakings required or permitted in any actions or proceedings allowed by law.

IN WITNESS WHEREOF, the Companies have caused this instrument to be signed and their corporate seals to be hereto affixed, this 28th day of September, 2010.

Farmington Casualty Company
Fidelity and Guaranty Insurance Company
Fidelity and Guaranty Insurance Underwriters, Inc.
St. Paul Fire and Marine Insurance Company
St. Paul Guardian Insurance Company

St. Paul Mercury Insurance Company
Travelers Casualty and Surety Company
Travelers Casualty and Surety Company of America
United States Fidelity and Guaranty Company



State of Connecticut
City of Hartford ss.

By: [Signature]
George W. Thompson, Senior Vice President

On this the 28th day of September, 2010, before me personally appeared George W. Thompson, who acknowledged himself to be the Senior Vice President of Farmington Casualty Company, Fidelity and Guaranty Insurance Company, Fidelity and Guaranty Insurance Underwriters, Inc., St. Paul Fire and Marine Insurance Company, St. Paul Guardian Insurance Company, St. Paul Mercury Insurance Company, Travelers Casualty and Surety Company, Travelers Casualty and Surety Company of America, and United States Fidelity and Guaranty Company, and that he, as such, being authorized so to do, executed the foregoing instrument for the purposes therein contained by signing on behalf of the corporations by himself as a duly authorized officer.

In Witness Whereof, I hereunto set my hand and official seal.
My Commission expires the 30th day of June, 2011.



[Signature]
Marie C. Tetreault, Notary Public

This Power of Attorney is granted under and by the authority of the following resolutions adopted by the Boards of Directors of Farmington Casualty Company, Fidelity and Guaranty Insurance Company, Fidelity and Guaranty Insurance Underwriters, Inc., St. Paul Fire and Marine Insurance Company, St. Paul Guardian Insurance Company, St. Paul Mercury Insurance Company, Travelers Casualty and Surety Company, Travelers Casualty and Surety Company of America, and United States Fidelity and Guaranty Company, which resolutions are now in full force and effect, reading as follows:

RESOLVED, that the Chairman, the President, any Vice Chairman, any Executive Vice President, any Senior Vice President, any Vice President, any Second Vice President, the Treasurer, any Assistant Treasurer, the Corporate Secretary or any Assistant Secretary may appoint Attorneys-in-Fact and Agents to act for and on behalf of the Company and may give such appointee such authority as his or her certificate of authority may prescribe to sign with the Company's name and seal with the Company's seal bonds, recognizances, contracts of indemnity, and other writings obligatory in the nature of a bond, recognizance, or conditional undertaking, and any of said officers or the Board of Directors at any time may remove any such appointee and revoke the power given him or her; and it is

FURTHER RESOLVED, that the Chairman, the President, any Vice Chairman, any Executive Vice President, any Senior Vice President or any Vice President may delegate all or any part of the foregoing authority to one or more officers or employees of this Company, provided that each such delegation is in writing and a copy thereof is filed in the office of the Secretary; and it is

FURTHER RESOLVED, that any bond, recognizance, contract of indemnity, or writing obligatory in the nature of a bond, recognizance, or conditional undertaking shall be valid and binding upon the Company when (a) signed by the President, any Vice Chairman, any Executive Vice President, any Senior Vice President or any Vice President, any Second Vice President, the Treasurer, any Assistant Treasurer, the Corporate Secretary or any Assistant Secretary and duly attested and sealed with the Company's seal by a Secretary or Assistant Secretary; or (b) duly executed (under seal, if required) by one or more Attorneys-in-Fact and Agents pursuant to the power prescribed in his or her certificate or their certificates of authority or by one or more Company officers pursuant to a written delegation of authority; and it is

FURTHER RESOLVED, that the signature of each of the following officers: President, any Executive Vice President, any Senior Vice President, any Vice President, any Assistant Vice President, any Secretary, any Assistant Secretary, and the seal of the Company may be affixed by facsimile to any Power of Attorney or to any certificate relating thereto appointing Resident Vice Presidents, Resident Assistant Secretaries or Attorneys-in-Fact for purposes only of executing and attesting bonds and undertakings and other writings obligatory in the nature thereof, and any such Power of Attorney or certificate bearing such facsimile signature or facsimile seal shall be valid and binding upon the Company and any such power so executed and certified by such facsimile signature and facsimile seal shall be valid and binding on the Company in the future with respect to any bond or understanding to which it is attached.

I, Kori M. Johanson, the undersigned, Assistant Secretary, of Farmington Casualty Company, Fidelity and Guaranty Insurance Company, Fidelity and Guaranty Insurance Underwriters, Inc., St. Paul Fire and Marine Insurance Company, St. Paul Guardian Insurance Company, St. Paul Mercury Insurance Company, Travelers Casualty and Surety Company, Travelers Casualty and Surety Company of America, and United States Fidelity and Guaranty Company do hereby certify that the above and foregoing is a true and correct copy of the Power of Attorney executed by said Companies, which is in full force and effect and has not been revoked.

IN TESTIMONY WHEREOF, I have hereunto set my hand and affixed the seals of said Companies this 19th day of October, 20 10.

Kori M. Johanson, Assistant Secretary



To verify the authenticity of this Power of Attorney, call 1-800-421-3880 or contact us at www.travelersbond.com. Please refer to the Attorney-In-Fact number, the above-named individuals and the details of the bond to which the power is attached.

Ratings & Analysis Center

United States | Asia Pacific | Canada | Europe

About | Contact | Sitemap

Ratings & Analysis ▾

- » Home
- » Best's Credit Ratings +
 - » Financial Strength Ratings—Insurer
 - » Issuer Credit Ratings
 - » Debt Ratings
 - » Financial Strength Ratings—Bank
 - » Advanced Search
- » About Best's Credit Ratings +
- » Get a Credit Rating +
- » Best's Special Reports
- » Add Best's Credit Ratings Search To Your Site
- » BestMark for Secure-Rated Insurers
- » Contact an Analyst

News & Research

Products & Services

Industry Information ▾

Corporate ▾

Support & Resources ▾

Conferences and Events ▾

Travelers Casualty and Surety Co America Print this page

(a member of [Travelers Group](#))

A.M. Best #: 003609 NAIC #: 31194 FEIN #: 060907370

Address: One Tower Square
Hartford, CT 06183
UNITED STATES

Phone: 860-277-0111

Fax: 860-277-7002

Web: www.travelers.com

Best's Ratings

Financial Strength Ratings [View Definitions](#) **Issuer Credit Ratings** [View Definitions](#)

Rating: **A+ (Superior)**

Financial Size Category: **XV** (\$2 Billion or greater)

Outlook: **Stable**

Action: **Affirmed**

Effective Date: **June 08, 2010**

* Denotes Under Review [Best's Ratings](#)

This rating is assigned to companies that have, in our opinion, a superior ability to meet their ongoing obligations to policyholders.

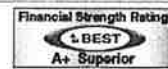

Member Center

For ratings and product access

[Login](#) | [Sign-up](#)

Find a Best's Credit Rating

Enter a Company Name

» [Advanced Search](#)



View Rating Definitions

Select one...

Reports and News

Visit our NewsRoom for the latest [news and press releases](#) for this company and its A.M. Best Group.

 **AMB Credit Report - Insurance Professional** - includes Best's Financial Strength Rating and rationale along with comprehensive analytical commentary, detailed business overview and key financial data.
Report Revision Date: 06/23/2010 (represents the latest significant change).
Historical Reports are available in [AMB Credit Report - Insurance Professional Archive](#).

 **Best's Executive Summary Reports (Financial Overview)** - available in three versions, these presentation style reports feature balance sheet, income statement, key financial performance tests including profitability, liquidity and reserve analysis.
Data Status: 2010 Best's Statement File - P/C, US. Contains data compiled as of 10/14/2010 (Quality Cross Checked).

- **Single Company** - five years of financial data specifically on this company.
- **Comparison** - side-by-side financial analysis of this company with a peer group of up to five other companies you select.
- **Composite** - evaluate this company's financials against a peer group composite. Report displays both the average and total composite of your selected peer group.

 **AMB Credit Report - Business Professional** - provides three years of key financial data presented with colorful charts and tables. Each report also features the latest Best's Ratings, Rating Rationale and an excerpt from our Business Review commentary.
Data Status: Contains data compiled as of 10/14/2010 (Quality Cross Checked).

 **Best's Key Rating Guide Presentation Report** - includes Best's Financial Strength Rating and financial data as provided in Best's Key Rating Guide products.
Data Status: 2009 Financial Data (Quality Cross Checked).

Financial and Analytical Products

- [Best's Key Rating Guide - P/C, US & Canada](#)
- [Best's Statement File - P/C, US](#)
- [Best's Statement File - Global](#)
- [Best's Insurance Reports - P/C, US & Canada](#)
- [Best's State Line - P/C, US](#)
- [Best's Insurance Expense Exhibit \(IEE\) - P/C, US](#)
- [Best's Schedule F \(Reinsurance\) - P/C, US](#)
- [Best's Schedule D \(Municipal Bonds\) - US](#)
- [Best's Schedule D \(Common Stocks\) - US](#)
- [Best's Corporate Changes and Retirements - P/C, US/CN](#)
- [Best's Schedule P \(Loss Reserves\) - P/C, US](#)
- [Best's Schedule D - Hybrid - P/C & L/H, US](#)
- [Best's Schedule D \(Corporate Bonds\) - US](#)
- [Best's Insurance Reports - Online - P/C, US & Canada](#)

Company Profile

TRAVELERS CASUALTY AND SURETY COMPANY OF AMERICA

ONE TOWER SQUARE, 4MN TRAVELERS / Mary T. Restelli
HARTFORD, CT 06183
877-872-8737

Former Names for Company

Old Name: AETNA CASUALTY & SURETY COMPANY OF AMERICA

Effective Date: 07-01-1997

Agent for Service of Process

KAREN HARRIS, C/O CORPORATION SERVICE COMPANY 2730 GATEWAY OAKS DRIVE, SUITE 100
SACRAMENTO, CA 95833

Unable to Locate the Agent for Service of Process?

Reference Information

NAIC #:	31194
NAIC Group #:	<u>3548</u>
California Company ID #:	2444-8
Date authorized in California:	July 31, 1981
License Status:	UNLIMITED-NORMAL
Company Type:	Property & Casualty
State of Domicile:	CONNECTICUT

Lines of Insurance Authorized to Transact

The company is authorized to transact business within these lines of insurance. For an explanation of any of these terms, please refer to the glossary.

AIRCRAFT
AUTOMOBILE
BOILER AND MACHINERY
BURGLARY
COMMON CARRIER LIABILITY
CREDIT
DISABILITY
FIRE
LIABILITY
MARINE
MISCELLANEOUS
PLATE GLASS
SPRINKLER
SURETY
TEAM AND VEHICLE
WORKERS' COMPENSATION

AGREEMENT

THIS AGREEMENT is entered into at Riverside, California as of the date set forth below is between County of Riverside hereafter called "County" and **FLATIRON ELECTRIC GROUP INC.** hereafter called "Contractor".

W I T N E S S E T H

RECITALS:

1. Contractor has submitted to County his Contractor's Proposal for the construction of County Project, **Countywide Traffic Signal Battery Backup System and LED Modules Improvements Project at Various Locations, Phase-1, Project No. B9-0996**, in strict accordance with the Contract Documents identified below and County has accepted said Proposal.
2. Contractor states that he has reexamined his Contractor's Proposal and found it to be correct, has ascertained that his subcontractors are properly licensed and possess the requisite skill and forces, has reexamined the site and Contract Documents and is of the opinion that he can presently do the work in accordance with the Contract Documents for the money set forth in his Proposal to be paid as provided in the Contract Documents.

AGREEMENT:

IT IS AGREED BY THE PARTIES AS FOLLOWS:

1. Contract Documents. The entire contract consists of the following: (a) The Agreement. (b) The Notice Inviting Bids. (c) The Instruction to Bidders. (d) The Contractor's Proposal. (e) The Bid Bond. (f) The Payment Bond. (g) The Performance Bond. (h) The General Conditions. (i) The Special Provisions. (j) The Standard Specifications of the State of California Department of Transportation edition of May 2006 as modified in other portions of the Contract Documents. (k) The Standard Plans of the Department of Transportation identified on the plans or in the Special Provisions. (l) The Plans. (m) Addenda **(1, 2, 3 &4)**. (n) The Determination of Prevailing Wage Rates for Public Work. (o) Any Change Orders issued. (p) Any additional or supplemental specifications, notice, instructions and drawings issued in accordance with the provisions of the Contract Documents. All of said Documents presently in existence are by this reference incorporated herein with like effect as if here set forth in full and upon the proper issuance of other documents they shall likewise be deemed incorporated. The Bid Bond is exonerated upon execution of this Agreement and the Payment Bond and Faithful Performance Bond.
2. The Work. Contractor shall do all things necessary to construct the work generally described in Recital No. 1 in accordance with the Contract Documents.

3. Liquidated Damages and Time of Completion. Attention is directed to the provisions in Section 8-1.06, "Time of Completion", and in Section 8-1.07, "Liquidated Damages", of the Standard Specifications and these Special Provisions.

The Contractor shall begin work within 15 days of the date stated within the written "Notice to Proceed".

The Contractor shall notify the Engineer, in writing, of his intent to begin work at least 72 hours before work is begun. The notice shall be delivered to the Transportation Department's Construction Engineer and shall specify the date the Contractor intends to start. If the project has more than one location of work, a separate notice shall be given for each location.

Should the Contractor begin work in advance of receiving a written "Notice to Proceed", any work performed by him in advance of the date stated in the "Notice to Proceed" shall be considered as having been done by him at his own risk and as a volunteer and subject to the following:

- (1) The Contractor shall, on commencing operations, take all precautions required for public safety and shall observe all the provisions in the Specifications and the Special Provisions.
 - (2) All work done according to the contract prior to the issuance of the "Notice to Proceed", will be considered authorized work and will be paid for as provided in the contract.
 - (3) The Contractor shall not be entitled to any additional compensation or an extension of time for any delay, hindrance or interference caused by or attributable to commencement of work prior to the issuance of the "Notice to Proceed".
4. Compensation. Contractor shall be paid in the manner set forth in the Contract Documents the amount of his Proposal as accepted by County, the above rates, subject to additions and deductions as provided in the Contract Documents. Said Proposal is on file in the Office of the Clerk of the Board of Supervisors of County.

**COUNTYWIDE TRAFFIC SIGNAL BATTERY BACKUP SYSTEM AND LED MODULES
IMPROVEMENTS PROJECT AT VARIOUS LOCATIONS, PHASE-1**

PROJECT No. B9-0996

AGREEMENT

ITEM No.	ITEM CODE	ITEM	UNIT	ESTIMATED QUANTITY	ITEM PRICE (IN FIGURES)	TOTAL (IN FIGURES)
1	120100	TRAFFIC CONTROL SYSTEM	LS	1	500.00	500.00
2	000003	12" RED ARROW LED TRAFFIC SIGNAL MODULE	EA	206	51.00	9,078.00
3	000003	12" GREEN ARROW LED TRAFFIC SIGNAL MODULE	EA	261	58.00	13,514.00
4	000003	12" RED BALL TRAFFIC SIGNAL MODULE	EA	625	51.00	26,571.00
5	000003	12" GREEN BALL TRAFFIC SIGNAL MODULE	EA	600	59.00	29,264.00
6	000003	PV RED TRAFFIC SIGNAL MODULE	EA	24	104.00	1,664.00
7	000003	PV GREEN TRAFFIC SIGNAL MODULE	EA	26	118.00	2,124.00
8	731521	MINOR CONCRETE (SIDEWALK)	SF	220	9.00	1,980.00
9	000003	BATTERY BACK-UP SYSTEM (MOUNT EXTERNALLY TO CONTROLER CABINET)	EA	46	3,585.00	139,815.00
10	000003	BATTERY BACK-UP SYSTEM (MOUNT INTERNALLY TO CONTROLLER CABINET)	EA	7	3,035.00	15,175.00

PROJECT
TOTAL:
ITEMS 1-10

Two hundred thirty nine thousand, six hundred eighty five dollars and zero cents \$239,685.00

"WORDS"

IN WITNESS WHEREOF the parties hereto have executed this agreement as of the date set forth below.

COUNTY OF RIVERSIDE

FLATIRON ELECTRIC GROUP INC.

BY Bob Buster
Chairman, Board of Supervisors
BOB BUSTER

BY [Signature]

Dated JAN 11 2011

TITLE: Vice President
(If Corporation, Affix Seal)

ATTEST:

Kecia Harper-Ihem, Clerk of the Board

ATTEST:

Shawn R. Bradfield

BY [Signature]
Deputy

TITLE: Office Manager

Licensed in accordance with an act providing for the registration of Contractors,

License No. 862724

Federal Employer Identification Number:

20-3076612

BY _____
"County"
(Seal)

"Corporation"
(Seal)

FORM APPROVED COUNTY COUNSEL

BY: [Signature] 12/21/10 DATE
MARSHA L. VICTOR

CALIFORNIA ALL-PURPOSE ACKNOWLEDGMENT

State of California

County of Los Angeles

On November 5, 2010 before me, Shawn R. Bradfield, Notary Public
Date Here Insert Name and Title of the Officer (e.g., "Jane Doe, Notary Public")
personally appeared Richard Tesoriero
Name(s) of Signer(s)

who proved to me on the basis of satisfactory evidence to be the person(s) whose name(s) is/are subscribed to the within instrument and acknowledged to me that he/she/they executed the same in his/her/their authorized capacity(ies), and that by his/her/their signature(s) on the instrument the person(s), or the entity upon behalf of which the person(s) acted, executed the instrument.



I certify under PENALTY OF PERJURY under the laws of the State of California that the foregoing paragraph is true and correct.

WITNESS my hand and official seal.

Signature Shawn R. Bradfield
Signature of Notary Public

OPTIONAL

Though the information below is not required by law, it may prove valuable to persons relying on the document and could prevent fraudulent removal and reattachment of this form to another document.

Description of Attached Document

Title or Type of Document: Agreement

Document Date: _____ No Date _____ Number of Pages: _____

Signer(s) Other Than Named Above: None

Capacity(ies) Claimed by Signer(s)

Signer's Name: Richard Tesoriero

- Individual
- Corporate Officer – Title(s): Vice President
- Partner – Limited General
- Attorney-in-Fact
- Trustee
- Guardian or Conservator
- Other: _____

Signer Is Representing: Flatiron Electric Group, Inc.

Signer's Name: _____

- Individual
- Corporate Officer – Title(s): _____
- Partner – Limited General
- Attorney-in-Fact
- Trustee
- Guardian or Conservator
- Other: _____

Signer Is Representing: _____

PERFORMANCE BOND

Recitals:

1. **Flatiron Electric Group Inc.** (Contractor) intend to enter into an Agreement with COUNTY OF RIVERSIDE (County) for construction of public work known as **Countywide Traffic Signal Battery Backup System and LED Modules Improvements Project at Various Locations, Phase-1, Project No. B9-0996.**

2. _____, a _____ corporation (Surety), is the Surety under this Bond.

Agreement:

We, Contractor, as Principal, and Surety, as Surety, jointly and severally agree, state, and are bound unto County, as obligee, as follows:

1. The amount of the obligation of this Bond is 100% of the estimated contract price for the Project of **\$ 239,685.00, Two hundred thirty nine thousand, six hundred eighty five dollars and zero cents** and inures to the benefit of County.

2. This Bond is exonerated by Contractor doing all things to be kept and performed by it in strict conformance with the Contract Documents for the Project, otherwise it remains in full force and effect for the recovery of loss, damage and expense of County resulting from failure of Contractor to so act. All of said Contract Documents are incorporated herein.

3. This obligation is binding on our successors and assigns.

4. For value received, Surety stipulates and agrees that no change, time extension, prepayment to Contractor, alteration or addition to the terms and requirements of the Contract Documents or the work to be performed thereunder shall affect its obligations hereunder and waives notice as to such matters, except the total contract price cannot be increased by more than 10% without approval of Surety.

THIS BOND is executed as of _____.

By _____

By _____

By _____

Type Name _____

Its Attorney in Fact
"Surety"

Title _____

"Contractor"
(Corporate Seal)

(Corporate Seal)

NOTE: This Bond must be executed by both parties with corporate seal affixed for each party. All signatures must be acknowledged. (Attach acknowledgements).

Executed in Duplicate
Premium Amount: \$2,132.00

Travelers Bond No.: 105439402
Federal Bond No.: 8219-72-63
F&D/Zurich Bond No.: 08981746
Liberty Bond No.: 015030847
CNA Bond No.: 929504968

PERFORMANCE BOND

Recitals:

1. **Flatiron Electric Group Inc.** (Contractor) intend to enter into an Agreement with COUNTY OF RIVERSIDE (County) for construction of public work known as **Countywide Traffic Signal Battery Backup System and LED Modules Improvements Project at Various Locations, Phase-1, Project No. B9-0996.**
2. SEE ATTACHMENT A, a SEE ATTACHEMENT A corporation (Surety), is the Surety under this Bond.

Agreement:

We, Contractor, as Principal, and Surety, as Surety, jointly and severally agree, state, and are bound unto County, as obligee, as follows:

1. The amount of the obligation of this Bond is 100% of the estimated contract price for the Project of **\$ 239,685.00, Two hundred thirty nine thousand, six hundred eighty five dollars and zero cents** and inures to the benefit of County.
2. This Bond is exonerated by Contractor doing all things to be kept and performed by it in strict conformance with the Contract Documents for the Project, otherwise it remains in full force and effect for the recovery of loss, damage and expense of County resulting from failure of Contractor to so act. All of said Contract Documents are incorporated herein.
3. This obligation is binding on our successors and assigns.
4. For value received, Surety stipulates and agrees that no change, time extension, prepayment to Contractor, alteration or addition to the terms and requirements of the Contract Documents or the work to be performed thereunder shall affect its obligations hereunder and waives notice as to such matters, except the total contract price cannot be increased by more than 10% without approval of Surety.

THIS BOND is executed as of November 4, 2010.

By Flatiron Electric Group, Inc.

By SEE ATTACHMENT A

By 

Type Name _____

Title Vice President
"Contractor"
(Corporate Seal)

Its Attorney in Fact
"Surety"

(Corporate Seal)

NOTE: This Bond must be executed by both parties with corporate seal affixed for each party. All signatures must be acknowledged. (Attach acknowledgements).

ATTACHMENT A

BOND NUMBERS:	Travelers	1054393402
	Federal	8219-72-63
	F&D/Zurich	08981746
	Liberty	015030847
	Continental	929504968

Travelers Casualty and Surety Company of America, a Connecticut corporation;
Federal Insurance Company, an Indiana corporation;
Fidelity and Deposit Company of Maryland, a Maryland corporation;
Zurich American Insurance Company, a New York corporation;
Liberty Mutual Insurance Company, a Massachusetts corporation;
The Continental Insurance Company, a Pennsylvania Corporation

Travelers Casualty and Surety Company of America – A.M. Best Rating A+ XV
Construction Services, One Tower Square, Hartford, CT 06183
Contact: Brien Bialaski, V.P. (860) 277-1914

By: 
Alice McLaughlin, Attorney-In-Fact
300 Tice Blvd., Suite 250 North, Woodcliff Lake, NJ 07677 (201) 644-2516

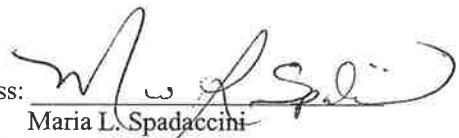
Witness: 
Maria L. Spadaccini

Federal Insurance Company – A.M. Best Rating A++ XV
15 Mountain View Road, Warren, NJ 07061
Contact: Matthew Lubin, Director, National Engineering and Construction Group (908) 903-2461

By: 
Alice McLaughlin, Attorney-In-Fact
300 Tice Blvd., Suite 250 North, Woodcliff Lake, NJ 07677 (201) 644-2516

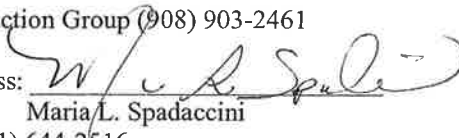
Witness: 
Maria L. Spadaccini

Fidelity and Deposit Company of Maryland – A.M. Best Rating A XV
1400 American Lane, Schaumburg, IL 60196
Contact: Thomas McClellan, Sr. Underwriting Officer (410) 559-8730

By: 
Alice McLaughlin, Attorney-In-Fact
300 Tice Blvd., Suite 250 North, Woodcliff Lake, NJ 07677 (201) 644-2516

Witness: 
Maria L. Spadaccini

Zurich American Insurance Company – A.M. Best Rating A XV
1400 American Lane, Schaumburg, IL 60196
Contact: Thomas McClellan, Sr. Underwriting Officer (410) 559-8730

By: 
Alice McLaughlin, Attorney-In-Fact
300 Tice Blvd., Suite 250 North, Woodcliff Lake, NJ 07677 (201) 644-2516

Witness: 
Maria L. Spadaccini

Liberty Mutual Insurance Company – A.M. Best Rating A XV
175 Berkeley Street, Boston, MA 02116
Contact: David D. Roberts, Branch Manager (212) 719-7750

By: 
Alice McLaughlin, Attorney-In-Fact
300 Tice Blvd., Suite 250 North, Woodcliff Lake, NJ 07677 (201) 644-2516

Witness: 
Maria L. Spadaccini

The Continental Insurance Company – A.M. Best Rating A XV
333 S. Wabash Avenue, Chicago, IL 60604
Contact: John Fullerton, Branch Manager (212) 440-7356

By: 
Alice McLaughlin, Attorney-In-Fact
300 Tice Blvd., Suite 250 North, Woodcliff Lake, NJ 07677 (201) 644-2516

Witness: 
Maria L. Spadaccini

CALIFORNIA ALL-PURPOSE ACKNOWLEDGMENT

State of California

County of Los Angeles

On November 5, 2010 before me, Shawn R. Bradfield, Notary Public
Date Here Insert Name and Title of the Officer (e.g., "Jane Doe, Notary Public")
personally appeared Richard Tesoriero
Name(s) of Signer(s)

who proved to me on the basis of satisfactory evidence to be the person(s) whose name(s) is/~~are~~ subscribed to the within instrument and acknowledged to me that he/~~she~~/they executed the same in his/~~her~~/their authorized capacity(ies), and that by his/~~her~~/their signature(s) on the instrument the person(s), or the entity upon behalf of which the person(s) acted, executed the instrument.



I certify under PENALTY OF PERJURY under the laws of the State of California that the foregoing paragraph is true and correct.

WITNESS my hand and official seal.

Signature Shawn R. Bradfield
Signature of Notary Public

OPTIONAL

Though the information below is not required by law, it may prove valuable to persons relying on the document and could prevent fraudulent removal and reattachment of this form to another document.

Description of Attached Document

Title or Type of Document: Performance Bond

Document Date: November 4, 2010 Number of Pages: _____

Signer(s) Other Than Named Above: Alice McLaughlin, Attorney-in-Fact

Capacity(ies) Claimed by Signer(s)

Signer's Name: Richard Tesoriero
 Individual
 Corporate Officer – Title(s): Vice President
 Partner – Limited General
 Attorney-in-Fact
 Trustee
 Guardian or Conservator
 Other: _____

Signer's Name: _____
 Individual
 Corporate Officer – Title(s): _____
 Partner – Limited General
 Attorney-in-Fact
 Trustee
 Guardian or Conservator
 Other: _____

Signer Is Representing: Flatiron Electric Group, Inc.

Signer Is Representing: _____

CORPORATE ACKNOWLEDGMENT

Form 152

STATE OF NEW JERSEY

COUNTY OF BERGEN

On this 4TH day of NOVEMBER, 2010, before me personally came ALICE McLAUGHLIN to me known, who, being by me duly sworn, did depose and say that she/he resides in NUTLEY, NEW JERSEY that she/he is the ATTORNEY IN FACT of the TRAVELERS CASUALTY AND SURETY COMPANY OF AMERICA the corporation described in and which executed the above instrument that she/he knows the seal of said corporation; that the seal affixed to said instrument is such corporate seal; that it was so affixed by order of the Board of Directors of said corporation, and that she/he signed her/his name thereto by like order.

(SEAL)

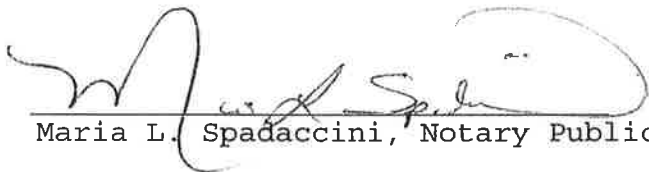
Maria L. Spadaccini, Notary Public

MARIA L. SPADACCINI
NOTARY PUBLIC OF NEW JERSEY
COMMISSION EXPIRES
MARCH 6, 2013

TRAVELERS CASUALTY AND SURETY COMPANY OF AMERICA

HARTFORD, CONNECTICUT 06183

FINANCIAL STATEMENT AS OF DECEMBER 31, 2009

CAPITAL STOCK \$ 6,480,000

ASSETS		LIABILITIES & SURPLUS	
CASH & INVESTED CASH	\$ 91,652,774	UNEARNED PREMIUMS	\$ 839,517,654
BONDS	3,673,398,048	LOSSES	889,279,087
INVESTMENT INCOME DUE AND ACCRUED	51,425,446	LOSS ADJUSTMENT EXPENSES	391,654,338
PREMIUM BALANCES	183,601,016	COMMISSIONS	54,630,588
NET DEFERRED TAX ASSET	72,285,733	TAXES, LICENSES AND FEES	59,474,472
REINSURANCE RECOVERABLE	4,839,080	OTHER EXPENSES	31,736,727
REINSURANCE RECEIVABLE INTERCOMPANY	247,774,291	FUNDS HELD UNDER REINSURANCE TREATIES	101,293,706
OTHER ASSETS	6,728,714	CURRENT FEDERAL AND FOREIGN INCOME TAXES	6,951,413
		REMITTANCES AND ITEMS NOT ALLOCATED	49,208,988
		AMOUNTS WITHHELD / RETAINED BY COMPANY FOR OTHERS	47,770,209
		RETROACTIVE REINSURANCE RESERVE	3,174,786
		POLICYHOLDER DIVIDENDS	8,825,721
		PROVISION FOR REINSURANCE	7,950,503
		CEDED REINSURANCE NET PREMIUMS PAYABLE	(47,012,192)
		PAYABLE TO PARENT, SUBSIDIARIES AND AFFILIATES	60,750,201
		OTHER ACCRUED EXPENSES AND LIABILITIES	1,322,861
		TOTAL LIABILITIES	\$ 2,484,857,039
		CAPITAL STOCK	\$ 6,480,000
		PAID IN SURPLUS	433,803,780
		OTHER SURPLUS	1,396,664,901
		TOTAL SURPLUS TO POLICYHOLDERS	\$ 1,836,848,681
TOTAL ASSETS	\$ 4,331,705,701	TOTAL LIABILITIES & SURPLUS	\$ 4,331,705,701

STATE OF CONNECTICUT)
 COUNTY OF HARTFORD) SS.
 CITY OF HARTFORD)

MICHAEL J. DOODY, BEING DULY SWORN, SAYS THAT HE IS SECOND VICE PRESIDENT, OF TRAVELERS CASUALTY AND SURETY COMPANY OF AMERICA, AND THAT TO THE BEST OF HIS KNOWLEDGE AND BELIEF, THE FOREGOING IS A TRUE AND CORRECT STATEMENT OF THE FINANCIAL CONDITION OF SAID COMPANY AS OF THE 31st DAY OF DECEMBER, 2009.



Michael J. Doody
 SECOND VICE PRESIDENT

 NOTARY PUBLIC -- MY COMMISSION EXPIRES 11/30/2012

SUBSCRIBED AND SWORN TO BEFORE ME THIS
 19th DAY OF APRIL, 2010



POWER OF ATTORNEY

Farmington Casualty Company
Fidelity and Guaranty Insurance Company
Fidelity and Guaranty Insurance Underwriters, Inc.
St. Paul Fire and Marine Insurance Company
St. Paul Guardian Insurance Company

St. Paul Mercury Insurance Company
Travelers Casualty and Surety Company
Travelers Casualty and Surety Company of America
United States Fidelity and Guaranty Company

Attorney-In Fact No. 222859

Certificate No. 003903460

KNOW ALL MEN BY THESE PRESENTS: That St. Paul Fire and Marine Insurance Company, St. Paul Guardian Insurance Company and St. Paul Mercury Insurance Company are corporations duly organized under the laws of the State of Minnesota, that Farmington Casualty Company, Travelers Casualty and Surety Company, and Travelers Casualty and Surety Company of America are corporations duly organized under the laws of the State of Connecticut, that United States Fidelity and Guaranty Company is a corporation duly organized under the laws of the State of Maryland, that Fidelity and Guaranty Insurance Company is a corporation duly organized under the laws of the State of Iowa, and that Fidelity and Guaranty Insurance Underwriters, Inc., is a corporation duly organized under the laws of the State of Wisconsin (herein collectively called the "Companies"), and that the Companies do hereby make, constitute and appoint

Sandra K. Wolf, Alice McLaughlin, Mary R. McKee, Sherryanne M. DePirro, and Maria L. Spadaccini

of the City of Woodcliff Lake, State of New Jersey, their true and lawful Attorney(s)-in-Fact, each in their separate capacity if more than one is named above, to sign, execute, seal and acknowledge any and all bonds, recognizances, conditional undertakings and other writings obligatory in the nature thereof on behalf of the Companies in their business of guaranteeing the fidelity of persons, guaranteeing the performance of contracts and executing or guaranteeing bonds and undertakings required or permitted in any actions or proceedings allowed by law.

IN WITNESS WHEREOF, the Companies have caused this instrument to be signed and their corporate seals to be hereto affixed, this 28th day of September, 2010.

Farmington Casualty Company
Fidelity and Guaranty Insurance Company
Fidelity and Guaranty Insurance Underwriters, Inc.
St. Paul Fire and Marine Insurance Company
St. Paul Guardian Insurance Company

St. Paul Mercury Insurance Company
Travelers Casualty and Surety Company
Travelers Casualty and Surety Company of America
United States Fidelity and Guaranty Company



State of Connecticut
City of Hartford ss.

By: [Signature]
George W. Thompson, Senior Vice President

On this the 28th day of September, 2010, before me personally appeared George W. Thompson, who acknowledged himself to be the Senior Vice President of Farmington Casualty Company, Fidelity and Guaranty Insurance Company, Fidelity and Guaranty Insurance Underwriters, Inc., St. Paul Fire and Marine Insurance Company, St. Paul Guardian Insurance Company, St. Paul Mercury Insurance Company, Travelers Casualty and Surety Company, Travelers Casualty and Surety Company of America, and United States Fidelity and Guaranty Company, and that he, as such, being authorized so to do, executed the foregoing instrument for the purposes therein contained by signing on behalf of the corporations by himself as a duly authorized officer.

In Witness Whereof, I hereunto set my hand and official seal.
My Commission expires the 30th day of June, 2011.



[Signature]
Marie C. Tetreault, Notary Public

This Power of Attorney is granted under and by the authority of the following resolutions adopted by the Boards of Directors of Farmington Casualty Company, Fidelity and Guaranty Insurance Company, Fidelity and Guaranty Insurance Underwriters, Inc., St. Paul Fire and Marine Insurance Company, St. Paul Guardian Insurance Company, St. Paul Mercury Insurance Company, Travelers Casualty and Surety Company, Travelers Casualty and Surety Company of America, and United States Fidelity and Guaranty Company, which resolutions are now in full force and effect, reading as follows:

RESOLVED, that the Chairman, the President, any Vice Chairman, any Executive Vice President, any Senior Vice President, any Vice President, any Second Vice President, the Treasurer, any Assistant Treasurer, the Corporate Secretary or any Assistant Secretary may appoint Attorneys-in-Fact and Agents to act for and on behalf of the Company and may give such appointee such authority as his or her certificate of authority may prescribe to sign with the Company's name and seal with the Company's seal bonds, recognizances, contracts of indemnity, and other writings obligatory in the nature of a bond, recognizance, or conditional undertaking, and any of said officers or the Board of Directors at any time may remove any such appointee and revoke the power given him or her; and it is

FURTHER RESOLVED, that the Chairman, the President, any Vice Chairman, any Executive Vice President, any Senior Vice President or any Vice President may delegate all or any part of the foregoing authority to one or more officers or employees of this Company, provided that each such delegation is in writing and a copy thereof is filed in the office of the Secretary; and it is

FURTHER RESOLVED, that any bond, recognizance, contract of indemnity, or writing obligatory in the nature of a bond, recognizance, or conditional undertaking shall be valid and binding upon the Company when (a) signed by the President, any Vice Chairman, any Executive Vice President, any Senior Vice President or any Vice President, any Second Vice President, the Treasurer, any Assistant Treasurer, the Corporate Secretary or any Assistant Secretary and duly attested and sealed with the Company's seal by a Secretary or Assistant Secretary; or (b) duly executed (under seal, if required) by one or more Attorneys-in-Fact and Agents pursuant to the power prescribed in his or her certificate or their certificates of authority or by one or more Company officers pursuant to a written delegation of authority; and it is

FURTHER RESOLVED, that the signature of each of the following officers: President, any Executive Vice President, any Senior Vice President, any Vice President, any Assistant Vice President, any Secretary, any Assistant Secretary, and the seal of the Company may be affixed by facsimile to any Power of Attorney or to any certificate relating thereto appointing Resident Vice Presidents, Resident Assistant Secretaries or Attorneys-in-Fact for purposes only of executing and attesting bonds and undertakings and other writings obligatory in the nature thereof, and any such Power of Attorney or certificate bearing such facsimile signature or facsimile seal shall be valid and binding upon the Company and any such power so executed and certified by such facsimile signature and facsimile seal shall be valid and binding on the Company in the future with respect to any bond or understanding to which it is attached.

I, Kori M. Johanson, the undersigned, Assistant Secretary, of Farmington Casualty Company, Fidelity and Guaranty Insurance Company, Fidelity and Guaranty Insurance Underwriters, Inc., St. Paul Fire and Marine Insurance Company, St. Paul Guardian Insurance Company, St. Paul Mercury Insurance Company, Travelers Casualty and Surety Company, Travelers Casualty and Surety Company of America, and United States Fidelity and Guaranty Company do hereby certify that the above and foregoing is a true and correct copy of the Power of Attorney executed by said Companies, which is in full force and effect and has not been revoked.

IN TESTIMONY WHEREOF, I have hereunto set my hand and affixed the seals of said Companies this 4th day of November, 2010.

Kori M. Johanson, Assistant Secretary



To verify the authenticity of this Power of Attorney, call 1-800-421-3880 or contact us at www.travelersbond.com. Please refer to the Attorney-In-Fact number, the above-named individuals and the details of the bond to which the power is attached.

CORPORATE ACKNOWLEDGMENT

Form 152

STATE OF NEW JERSEY

COUNTY OF BERGEN

On this 4TH day of NOVEMBER, 2010, before me personally came ALICE McLAUGHLIN to me known, who, being by me duly sworn, did depose and say that she/he resides in NUTLEY, NEW JERSEY that she/he is the ATTORNEY IN FACT of the FEDERAL INSURANCE COMPANY the corporation described in and which executed the above instrument that she/he knows the seal of said corporation; that the seal affixed to said instrument is such corporate seal; that it was so affixed by order of the Board of Directors of said corporation, and that she/he signed her/his name thereto by like order.

(SEAL)



Maria L. Spadaccini, Notary Public

MARIA L. SPADACCINI
NOTARY PUBLIC OF NEW JERSEY
COMMISSION EXPIRES
MARCH 6, 2013

FEDERAL INSURANCE COMPANY

STATEMENT OF ASSETS, LIABILITIES AND SURPLUS TO POLICYHOLDERS

Statutory Basis

DECEMBER 31, 2009

(in thousands of dollars)

ASSETS	LIABILITIES AND SURPLUS TO POLICYHOLDERS
Cash and Short Term Investments..... \$ 257,630	Outstanding Losses and Loss Expenses \$ 11,900,150
United States Government, State and Municipal Bonds..... 11,077,454	Unearned Premiums..... 3,345,760
Other Bonds..... 4,042,056	Reinsurance Premiums Payable 322,875
Stocks 778,949	Provision for Reinsurance 79,993
Other Invested Assets..... 1,758,696	Other Liabilities..... 717,789
TOTAL INVESTMENTS..... 17,914,785	TOTAL LIABILITIES 16,366,567
Investments in Affiliates:	Special Surplus Funds..... 176,031
Chubb Investment Holdings, Inc..... 2,881,003	Capital Stock 20,980
Pacific Indemnity Company 2,200,172	Paid-In Surplus..... 3,106,809
Chubb Insurance Investment Holdings Ltd. ... 1,539,334	Unassigned Funds..... 11,017,701
Executive Risk Indemnity Inc..... 1,078,688	
CC Canada Holdings Ltd..... 607,555	SURPLUS TO POLICYHOLDERS..... 14,321,521
Great Northern Insurance Company 453,227	
Chubb European Investment Holdings SLP . 271,092	
Chubb Insurance Company of Australia... 255,177	
Vigilant Insurance Company..... 176,625	
Other Affiliates 349,088	
Premiums Receivable..... 1,458,416	TOTAL LIABILITIES AND SURPLUS TO POLICYHOLDERS..... \$ 30,688,088
Other Assets 1,502,926	
TOTAL ADMITTED ASSETS \$ 30,688,088	

Investments are valued in accordance with requirements of the National Association of Insurance Commissioners.
Investments valued at \$448,814,488 are deposited with government authorities as required by law.

State, County & City of New York, — ss:

Yvonne Baker, Assistant Secretary _____ of the Federal Insurance Company
being duly sworn, deposes and says that the foregoing Statement of Assets, Liabilities and Surplus to Policyholders of said
Federal Insurance Company on December 31, 2009 is true and correct and is a true abstract of the Annual Statement of said
Company as filed with the Secretary of the Treasury of the United States for the 12 months ending December 31, 2009.

Subscribed and sworn to before me
this



Notary Public

DOROTHY M. BAKER
Notary Public, State of New York
No. 31-4904994
Qualified in New York County
Commission Expires Sept. 14, 2013



Assistant Secretary

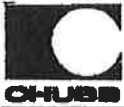

**Chubb
Surety**

**POWER
OF
ATTORNEY**

**Federal Insurance Company
Vigilant Insurance Company
Pacific Indemnity Company**

**Attn: Surety Department
15 Mountain View Road
Warren, NJ 07059**

Know All by These Presents, That FEDERAL INSURANCE COMPANY, an Indiana corporation, VIGILANT INSURANCE COMPANY, a New York corporation, and PACIFIC INDEMNITY COMPANY, a Wisconsin corporation, do each hereby constitute and appoint Sherryanne M. DePirro, Mary R. McKee, Alice McLaughlin, Maria L. Spadaccini and Sandra K. Wolf of Woodcliff Lake, New Jersey

each as their true and lawful Attorney- In- Fact to execute under such designation in their names and to affix their corporate seals to and deliver for and on their behalf as surety thereon or otherwise, bonds and undertakings and other writings obligatory in the nature thereof (other than bail bonds) given or executed in the course of business, and any instruments amending or altering the same, and consents to the modification or alteration of any instrument referred to in said bonds or obligations.

In Witness Whereof, said FEDERAL INSURANCE COMPANY, VIGILANT INSURANCE COMPANY, and PACIFIC INDEMNITY COMPANY have each executed and attested these presents and affixed their corporate seals on this **22nd** day of **September, 2010**.

Kenneth C. Wendel, Assistant Secretary

Richard A. Ciullo, Vice President

STATE OF NEW JERSEY
County of Somerset ss.

On this **22nd** day of **September, 2010** before me, a Notary Public of New Jersey, personally came Kenneth C. Wendel, to me known to be Assistant Secretary of FEDERAL INSURANCE COMPANY, VIGILANT INSURANCE COMPANY, and PACIFIC INDEMNITY COMPANY, the companies which executed the foregoing Power of Attorney, and the said Kenneth C. Wendel, being by me duly sworn, did depose and say that he is Assistant Secretary of FEDERAL INSURANCE COMPANY, VIGILANT INSURANCE COMPANY, and PACIFIC INDEMNITY COMPANY and knows the corporate seals thereof, that the seals affixed to the foregoing Power of Attorney are such corporate seals and were thereto affixed by authority of the By- Laws of said Companies; and that he signed said Power of Attorney as Assistant Secretary of said Companies by like authority; and that he is acquainted with Richard A. Ciullo, and knows him to be Vice President of said Companies; and that the signature of Richard A. Ciullo, subscribed to said Power of Attorney is in the genuine handwriting of Richard A. Ciullo, and was thereto subscribed by authority of said By- Laws and in deponent's presence.

Notarial Seal



KATHERINE J. ADELAAR
NOTARY PUBLIC OF NEW JERSEY
No. 2316685
Commission Expires July 16, 2014

Notary Public

CERTIFICATION

Extract from the By- Laws of FEDERAL INSURANCE COMPANY, VIGILANT INSURANCE COMPANY, and PACIFIC INDEMNITY COMPANY:

"All powers of attorney for and on behalf of the Company may and shall be executed in the name and on behalf of the Company, either by the Chairman or the President or a Vice President or an Assistant Vice President, jointly with the Secretary or an Assistant Secretary, under their respective designations. The signature of such officers may be engraved, printed or lithographed. The signature of each of the following officers: Chairman, President, any Vice President, any Assistant Vice President, any Secretary, any Assistant Secretary and the seal of the Company may be affixed by facsimile to any power of attorney or to any certificate relating thereto appointing Assistant Secretaries or Attorneys- in- Fact for purposes only of executing and attesting bonds and undertakings and other writings obligatory in the nature thereof, and any such power of attorney or certificate bearing such facsimile signature or facsimile seal shall be valid and binding upon the Company and any such power so executed and certified by such facsimile signature and facsimile seal shall be valid and binding upon the Company with respect to any bond or undertaking to which it is attached."

I, Kenneth C. Wendel, Assistant Secretary of FEDERAL INSURANCE COMPANY, VIGILANT INSURANCE COMPANY, and PACIFIC INDEMNITY COMPANY (the "Companies") do hereby certify that

- (i) the foregoing extract of the By- Laws of the Companies is true and correct,
- (ii) the Companies are duly licensed and authorized to transact surety business in all 50 of the United States of America and the District of Columbia and are authorized by the U.S. Treasury Department; further, Federal and Vigilant are licensed in Puerto Rico and the U.S. Virgin Islands, and Federal is licensed in American Samoa, Guam, and each of the Provinces of Canada except Prince Edward Island; and
- (iii) the foregoing Power of Attorney is true, correct and in full force and effect.

Given under my hand and seals of said Companies at Warren, NJ this 4th of November, 2010.



Kenneth C. Wendel, Assistant Secretary

IN THE EVENT YOU WISH TO NOTIFY US OF A CLAIM, VERIFY THE AUTHENTICITY OF THIS BOND OR NOTIFY US OF ANY OTHER MATTER, PLEASE CONTACT US AT ADDRESS LISTED ABOVE, OR BY Telephone (908) 903- 3493 Fax (908) 903- 3656 e-mail: surety@chubb.com

CORPORATE ACKNOWLEDGMENT

Form 152

STATE OF NEW JERSEY

COUNTY OF BERGEN

On this 4TH day of NOVEMBER, 2010, before me personally came ALICE McLAUGHLIN to me known, who, being by me duly sworn, did depose and say that she/he resides in NUTLEY, NEW JERSEY that she/he is the ATTORNEY IN FACT of the FIDELITY AND DEPOSIT COMPANY OF MARYLAND the corporation described in and which executed the above instrument that she/he knows the seal of said corporation; that the seal affixed to said instrument is such corporate seal; that it was so affixed by order of the Board of Directors of said corporation, and that she/he signed her/his name thereto by like order.

(SEAL)

Maria L. Spadaccini, Notary Public

MARIA L. SPADACCINI
NOTARY PUBLIC OF NEW JERSEY
COMMISSION EXPIRES
MARCH 6, 2013

FIDELITY AND DEPOSIT COMPANY

OF MARYLAND

3910 KESWICK ROAD, BALTIMORE, MD 21211-2226

Statement of Financial Condition

As Of December 31, 2009

ASSETS

Bonds	\$ 156,584,995
Stocks	22,537,672
Cash and Short Term Investments	9,719,598
Reinsurance Recoverable	9,347,241
Other Accounts Receivable	51,052,264
TOTAL ADMITTED ASSETS	\$ 249,241,769

LIABILITIES, SURPLUS AND OTHER FUNDS

Reserve for Taxes and Expenses	\$ 76,835
Ceded Reinsurance Premiums Payable	58,237,612
Securities Lending Collateral Liability	5,511,875
TOTAL LIABILITIES	\$ 63,826,322
Capital Stock, Paid Up	\$ 5,000,000
Surplus	180,415,448
Surplus as regards Policyholders	185,415,447
TOTAL	\$ 249,241,769

Securities carried at \$38,385,957 in the above statement are deposited as required by law.

Securities carried on the basis prescribed by the National Association of Insurance Commissioners. On the basis of December 31, 2009 market quotations for all bonds and stocks owned, the Company's total admitted assets would be \$247,657,513 and surplus as regards policyholders \$186,999,703.

I, DENNIS F. KERRIGAN, Corporate Secretary of the FIDELITY AND DEPOSIT COMPANY OF MARYLAND, do hereby certify that the foregoing statement is a correct exhibit of the assets and liabilities of the said Company on the 31st day of December, 2009.



 Corporate Secretary

State of Illinois }
City of Schaumburg } SS:

Subscribed and sworn to, before me, a Notary Public of the State of Illinois, in the City of Schaumburg, this 15th day of March, 2010.



 Notary Public

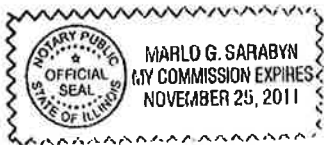

Power of Attorney
FIDELITY AND DEPOSIT COMPANY OF MARYLAND

KNOW ALL MEN BY THESE PRESENTS: That the FIDELITY AND DEPOSIT COMPANY OF MARYLAND, a corporation of the State of Maryland, by WILLIAM J. MILLS, Vice President, and GERALD F. HALEY, Assistant Secretary, in pursuance of authority granted by Article VI, Section 2, of the By-Laws of said Company, which are set forth on the reverse side hereof and are hereby certified to be in full force and effect on the date hereof, does hereby nominate, constitute and appoint **Sandra K. WOLF, Alice MCLAUGHLIN, Mary R. MCKEE and Sherryanne M. DEPIRRO, all of Woodcliff Lake, New Jersey, EACH** its true and lawful agent and Attorney-in-Fact, to make, execute, seal and deliver, for, and on its behalf as surety, and as its act and deed, ~~any and all bonds and undertakings~~, and the execution of such bonds or undertakings in pursuance of these presents, shall be as binding upon said Company, as fully and amply, to all intents and purposes, as if they had been duly executed and acknowledged by the regularly elected officers of the Company at its office in Baltimore, Md, in their own proper persons. This power of attorney revokes that issued on behalf of Sandra K. WOLF, Alice MCLAUGHLIN, Mary R. MCKEE, Sherryanne DEPIRRO, dated March 28, 2008.

The said Assistant Secretary does hereby certify that the extract set forth on the reverse side hereof is a true copy of Article VI, Section 2, of the By-Laws of said Company, and is now in force.

IN WITNESS WHEREOF, the said Vice-President and Assistant Secretary have hereunto subscribed their names and affixed the Corporate Seal of the said FIDELITY AND DEPOSIT COMPANY OF MARYLAND, this 22nd day of April, A.D. 2008.

ATTEST:

FIDELITY AND DEPOSIT COMPANY OF MARYLAND



Gerald F. Haley

Gerald F. Haley Assistant Secretary

William J. Mills

By:

William J. Mills

Vice President

State of Maryland }
City of Baltimore } ss:

On this 22nd day of April, A.D. 2008, before the subscriber, a Notary Public of the State of Maryland, duly commissioned and qualified, came WILLIAM J. MILLS, Vice President, and GERALD F. HALEY, Assistant Secretary of the FIDELITY AND DEPOSIT COMPANY OF MARYLAND, to me personally known to be the individuals and officers described in and who executed the preceding instrument, and they each acknowledged the execution of the same, and being by me duly sworn, severally and each for himself deposed and saith, that they are the said officers of the Company aforesaid, and that the seal affixed to the preceding instrument is the Corporate Seal of said Company, and that the said Corporate Seal and their signatures as such officers were duly affixed and subscribed to the said instrument by the authority and direction of the said Corporation.

IN TESTIMONY WHEREOF, I have hereunto set my hand and affixed my Official Seal the day and year first above written.



Maria D. Adamski

Maria D. Adamski

Notary Public

My Commission Expires: July 8, 2011

EXTRACT FROM BY-LAWS OF FIDELITY AND DEPOSIT COMPANY OF MARYLAND

“Article VI, Section 2. The Chairman of the Board, or the President, or any Executive Vice-President, or any of the Senior Vice-Presidents or Vice-Presidents specially authorized so to do by the Board of Directors or by the Executive Committee, shall have power, by and with the concurrence of the Secretary or any one of the Assistant Secretaries, to appoint Resident Vice-Presidents, Assistant Vice-Presidents and Attorneys-in-Fact as the business of the Company may require, or to authorize any person or persons to execute on behalf of the Company any bonds, undertakings, recognizances, stipulations, policies, contracts, agreements, deeds, and releases and assignments of judgements, decrees, mortgages and instruments in the nature of mortgages,...and to affix the seal of the Company thereto.”

CERTIFICATE

I, the undersigned, Assistant Secretary of the FIDELITY AND DEPOSIT COMPANY OF MARYLAND, do hereby certify that the foregoing Power of Attorney is still in full force and effect on the date of this certificate; and I do further certify that the Vice-President who executed the said Power of Attorney was one of the additional Vice-Presidents specially authorized by the Board of Directors to appoint any Attorney-in-Fact as provided in Article VI, Section 2, of the By-Laws of the FIDELITY AND DEPOSIT COMPANY OF MARYLAND.

This Power of Attorney and Certificate may be signed by facsimile under and by authority of the following resolution of the Board of Directors of the FIDELITY AND DEPOSIT COMPANY OF MARYLAND at a meeting duly called and held on the 10th day of May, 1990.

RESOLVED: "That the facsimile or mechanically reproduced seal of the company and facsimile or mechanically reproduced signature of any Vice-President, Secretary, or Assistant Secretary of the Company, whether made heretofore or hereafter, wherever appearing upon a certified copy of any power of attorney issued by the Company, shall be valid and binding upon the Company with the same force and effect as though manually affixed."

IN TESTIMONY WHEREOF, I have hereunto subscribed my name and affixed the corporate seal of the said Company,

this 4th day of November, 2010.

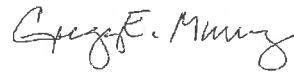

Assistant Secretary

CORPORATE ACKNOWLEDGMENT

Form 152

STATE OF NEW JERSEY

COUNTY OF BERGEN

On this 4TH day of NOVEMBER, 2010, before me personally came ALICE McLAUGHLIN to me known, who, being by me duly sworn, did depose and say that she/he resides in NUTLEY, NEW JERSEY that she/he is the ATTORNEY IN FACT of the ZURICH AMERICAN INSURANCE COMPANY the corporation described in and which executed the above instrument that she/he knows the seal of said corporation; that the seal affixed to said instrument is such corporate seal; that it was so affixed by order of the Board of Directors of said corporation, and that she/he signed her/his name thereto by like order.

(SEAL)



Maria L. Spadaccini, Notary Public

MARIA L. SPADACCINI
NOTARY PUBLIC OF NEW JERSEY
COMMISSION EXPIRES
MARCH 8, 2013

ZURICH AMERICAN INSURANCE COMPANY
COMPARATIVE BALANCE SHEET
ONE LIBERTY PLAZA, 165 BROADWAY, 32nd FLOOR, NEW YORK, NY 10006
As of December 31, 2009 and December 31, 2008

	12/31/2009	12/31/2008
<u>Assets</u>		
Bonds	\$ 18,856,255,156	\$ 18,080,264,654
Preferred Stock	983,952	70,077,341
Common Stock	2,414,799,006	2,523,871,473
Real Estate	-	25,457,836
Other Invested Assets	1,955,583,185	1,699,943,998
Short-term Investments	442,083,498	117,588,071
Receivable for securities	924,864	8,050,472
Cash and cash equivalents	81,175,295	66,140,854
Employee Trust for Deferred Compensation Plan	115,265,399	92,484,754
Total Cash and Invested Assets	\$ 23,867,070,354	\$ 22,683,879,453
Premiums Receivable	\$ 3,789,891,423	\$ 4,504,508,588
Funds Held with Reinsurers	17,543,464	18,761,471
Reinsurance Recoverable	334,417,233	859,700,252
Accrued Investment Income	153,168,265	149,763,601
Federal Income Tax Recoverable	938,076,547	583,896,990
Due from Affiliates	270,234,627	178,313,325
Other Assets	565,343,140	655,646,493
Total Assets	\$ 29,935,745,054	\$ 29,634,470,173
<u>Liabilities and Policyholders' Surplus</u>		
Liabilities:		
Loss and LAE Reserves	\$ 14,457,673,205	\$ 14,645,410,951
Unearned Premium Reserve	4,286,806,531	4,602,631,426
Funds Held with Reinsurers	249,802,186	248,918,770
Loss In Course of Payment	416,324,234	460,126,217
Commission Reserve	154,104,769	155,353,168
Federal Income Tax Payable	24,130,322	16,936,764
Remittances and Items Unallocated	152,534,594	135,262,884
Payable to parent, subs and affiliates	304,648,750	199,894,895
Provision for Reinsurance	74,859,513	95,167,954
Ceded Reinsurance Premiums Payable	62,782,469	605,799,518
Securities Lending Collateral Liability	328,068,754	102,593,522
Other Liabilities	2,006,859,109	2,126,543,703
Total Liabilities	\$ 22,518,594,436	\$ 23,394,639,772
Policyholders' Surplus:		
Common Capital Stock	\$ 5,000,000	\$ 5,000,000
Paid-in and Contributed Surplus	4,394,131,321	4,394,131,321
Surplus Notes	1,883,000,000	1,883,000,000
Special Surplus Retroactive Reinsurance	101,720,000	73,761,000
Change in Net Deferred Tax Asset	348,814,703	-
Cumulative Unrealized Gain	(74,742,079)	(316,593,413)
Dividends Undeclared	-	222,129
Loss Portfolio Transfer Account	-	-
Unassigned Surplus	759,226,673	200,309,364
Total Policyholders' Surplus	\$ 7,417,150,618	\$ 6,239,830,401
Total Liabilities and Policyholders' Surplus	\$ 29,935,745,054	\$ 29,634,470,173

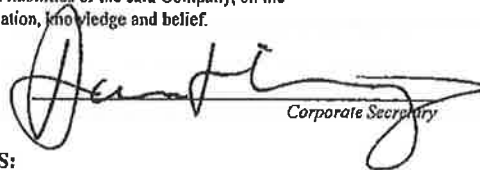
I, Dennis F. Kerrigan, Corporate Secretary of ZURICH AMERICAN INSURANCE COMPANY do hereby certify that the foregoing statement is a correct exhibit of the assets and liabilities of the said Company, on the 31st day of December, 2009, according to the best of my information, knowledge and belief.



 Corporate Secretary

State of Illinois
 County of Cook

} SS:

Subscribed and sworn to, before me, a Notary Public of the State of Illinois, in the City of Schaumburg, this 15th day of March, 2010.

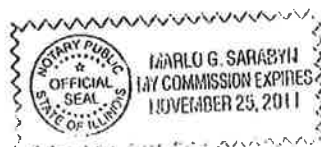

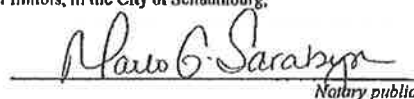

 Notary public

ZURICH AMERICAN INSURANCE COMPANY

POWER OF ATTORNEY

KNOW ALL MEN BY THESE PRESENTS, that the ZURICH AMERICAN INSURANCE COMPANY, a corporation created by and existing under the laws of the State of New York does hereby nominate, constitute and appoint Sandra K. WOLF, Alice MCLAUGHLIN, Mary R. MCKEE and Sherryanne M. DEPIRRO, all of Woodcliff Lake, New Jersey, EACH its true and lawful Attorneys-In-Fact with power and authority hereby conferred to sign, seal, and execute in its behalf, during the period beginning with the date of issuance of this power, : any and all bonds and undertakings, recognizances or other written obligations in the nature thereof, and to bind ZURICH AMERICAN INSURANCE COMPANY thereby, and all of the acts of said Attorney[s]-in-Fact pursuant to these presents are hereby ratified and confirmed . This Power of Attorney is made and executed pursuant to and by the authority of the following By-Law duly adopted by the Board of Directors of the Company which By-Law has not been amended or rescinded.

Article VI, Section 5. "...The President or a Vice President in a written instrument attested by a Secretary or an Assistant Secretary may appoint any person Attorney-In-Fact with authority to execute surety bonds on behalf of the Company and other formal underwriting contracts in reference thereto and reinsurance agreements relating to individual policies and bonds of all kinds and attach the corporate seal. Any such officers may revoke the powers granted to any Attorney-In-Fact."

This Power of Attorney is signed and sealed by facsimile under and by the authority of the following Resolution adopted by the Board of Directors of the ZURICH AMERICAN INSURANCE COMPANY by unanimous consent in lieu of a special meeting dated December 15, 1998

" RESOLVED, that the signature of the President or a Vice President and the attesting signature of a Secretary or an Assistant Secretary and the seal of the Company may be affixed by facsimile on any Power of Attorney pursuant to Article VI, Section 5 of the By-Laws, and the signature of a Secretary or an Assistant Secretary and the seal of the Company may be affixed by facsimile to any certificate of any such power. Any such power or any certificate thereof with such facsimile signature and seal shall be valid and binding on the Company. Furthermore, such power so executed, sealed and certified by certificate so executed and sealed shall, with respect to any bond or undertaking to which it is attached, shall continue to be valid and binding on the Company."

IN WITNESS WHEREOF, the ZURICH AMERICAN INSURANCE COMPANY has caused these presents to be executed in its name and on its behalf and its Corporate Seal to be hereunto affixed and attested by its officers thereunto duly authorized, this 22nd day of April, A.D. 2008. This power of attorney revokes that issued on behalf of Sandra K. WOLF, Alice MCLAUGHLIN, Mary R. MCKEE, Sherryanne DEPIRRO, dated March 28, 2008.



ZURICH AMERICAN INSURANCE COMPANY

Gerald F. Haley

Frank E. Martin Jr.

STATE OF MARYLAND }
CITY OF BALTIMORE }

SS: Gerald F. Haley

Secretary

By:

Frank E. Martin Jr.

Vice President

On the 22nd day of April, A.D. 2008, before the subscriber, a Notary Public of the State of Maryland, duly commissioned and qualified, came the above named Vice President and Secretary of ZURICH AMERICAN INSURANCE COMPANY, to me personally known to be the individuals and officers described in and who executed the preceding instrument and they each acknowledged the execution of the same and being by me duly sworn, they severally and each for himself deposed and said that they respectively hold the offices in said Corporation as indicated, that the Seal affixed to the preceding instrument is the Corporate Seal of said Corporation, and that the said Corporate Seal, and their respective signature as such officers, were duly affixed and subscribed to the said instrument pursuant to all due corporate authorization.

IN WITNESS WHEREOF, I have hereunto set my hand and affixed my Official Seal the day and year first above.



Maria D. Alamb

Notary Public

My Commission Expires: July 8, 2011

This Power of Attorney limits the acts of those named therein to the bonds and undertaking specifically named therein, and they have no authority to bind the Company except in the manner and to the extent herein stated.

CERTIFICATE

I, the undersigned, a Secretary of the ZURICH AMERICAN INSURANCE COMPANY, do hereby certify that the foregoing Power of Attorney is still in full force and effect, and further certify that Article VI, Section 5 of the By-Laws of the Company and the Resolution of the Board of Directors set forth in said Power of Attorney are still in force.

IN TESTIMONY WHEREOF I have hereto subscribed my name and affixed the seal of said Company

Gregory E. Murray

the 4th day of November, 2010

Gregory E. Murray

Secretary



CORPORATE ACKNOWLEDGMENT

Form 152

STATE OF NEW JERSEY

COUNTY OF BERGEN

On this 4TH day of NOVEMBER, 2010, before me personally came ALICE McLAUGHLIN to me known, who, being by me duly sworn, did depose and say that she/he resides in NUTLEY, NEW JERSEY that she/he is the ATTORNEY IN FACT of the LIBERTY MUTUAL INSURANCE COMPANY the corporation described in and which executed the above instrument that she/he knows the seal of said corporation; that the seal affixed to said instrument is such corporate seal; that it was so affixed by order of the Board of Directors of said corporation, and that she/he signed her/his name thereto by like order.

(SEAL)



Maria L. Spadaccini, Notary Public

MARIA L. SPADACCINI
NOTARY PUBLIC OF NEW JERSEY
COMMISSION EXPIRES
SEPTEMBER 9, 2013

ASSETS

	Current Year			Prior Year
	1	2	3	4
	Assets	Nonadmitted Assets	Net Admitted Assets (Cols. 1 - 2)	Net Admitted Assets
1. Bonds (Schedule D)	11,425,766,895		11,425,766,895	11,057,669,501
2. Stocks (Schedule D):				
2.1 Preferred stocks	762,976,318		762,976,318	757,319,706
2.2 Common stocks	9,135,552,552		9,135,552,552	7,570,471,320
3. Mortgage loans on real estate (Schedule B):				
3.1 First liens	519,022,709		519,022,709	548,091,252
3.2 Other than first liens				
4. Real estate (Schedule A):				
4.1 Properties occupied by the company (less \$ 0 encumbrances)	337,179,530		337,179,530	425,989,168
4.2 Properties held for the production of income (less \$ 0 encumbrances)	978,262		978,262	1,039,982
4.3 Properties held for sale (less \$ 0 encumbrances)				
5. Cash (\$ 389,502,555, Schedule E - Part 1), cash equivalents (\$ 82,179,054, Schedule E - Part 2), and short-term investments (\$ 352,850,853, Schedule DA)	824,332,462		824,332,462	1,349,305,516
6. Contract loans (including \$ 0 premium notes)				
7. Other invested assets (Schedule BA)	5,771,150,576	206,157	5,770,944,419	5,131,343,213
8. Receivables for securities	12,271,548		12,271,548	2,859,056
9. Aggregate write-ins for invested assets				
10. Subtotals, cash and invested assets (Lines 1 to 9)	28,809,230,852	206,157	28,809,024,695	26,844,068,712
11. Title plants less \$ 0 charged off (for Title Insurers only)				
12. Investment income due and accrued	133,128,777		133,128,777	140,188,757
13. Premiums and considerations:				
13.1 Uncollected premiums and agents' balances in the course of collection	993,284,743	14,732,220	978,552,523	1,071,899,224
13.2 Deferred premiums, agents' balances and installments booked but deferred and not yet due (including \$ 0 earned but unbilled premiums)	1,519,480,073		1,519,480,073	1,594,927,150
13.3 Accrued retrospective premiums	366,445,346	36,644,535	329,800,811	383,094,097
14. Reinsurance:				
14.1 Amounts recoverable from reinsurers	593,195,507		593,195,507	560,300,803
14.2 Funds held by or deposited with reinsured companies	13,527,020		13,527,020	17,294,633
14.3 Other amounts receivable under reinsurance contracts				
15. Amounts receivable relating to uninsured plans	21,095	11,418	9,677	175,315
16.1 Current federal and foreign income tax recoverable and interest thereon	313,172,056		313,172,056	
16.2 Net deferred tax asset	1,188,251,090	164,925,490	1,023,325,600	846,790,256
17. Guaranty funds receivable or on deposit	33,248,467		33,248,467	32,569,328
18. Electronic data processing equipment and software	319,102,379	257,221,814	61,880,565	50,291,004
19. Furniture and equipment, including health care delivery assets (\$ 0)	129,014,225	129,014,225		
20. Net adjustment in assets and liabilities due to foreign exchange rates				
21. Receivables from parent, subsidiaries and affiliates	348,223,617	610	348,223,007	312,158,606
22. Health care (\$ 0) and other amounts receivable				
23. Aggregate write-ins for other than invested assets	715,856,703	39,949,958	675,906,747	715,420,301
24. Total assets excluding Separate Accounts, Segregated Accounts and Protected Cell Accounts (Lines 10 to 23)	35,470,142,960	639,706,425	34,830,436,535	32,549,788,186
25. From Separate Accounts, Segregated Accounts and Protected Cell Accounts				
26. Total (Lines 24 and 25)	35,470,142,960	639,706,425	34,830,436,535	32,549,788,186

DETAILS OF WRITE-IN LINES				
0901.				
0902.				
0903.				
0998. Summary of remaining write-ins for Line 09 from overflow page				
0999. Totals (Lines 0901 through 0903 plus 0998) (Line 8 above)				
2301. Cash Surrender Value Life Insurance	383,284,398		383,284,398	348,631,623
2302. Amounts receivable under high deductible policies	172,319,200	115,051	172,204,149	165,149,487
2303. Other assets	132,718,497	39,834,802	92,883,695	155,597,198
2398. Summary of remaining write-ins for Line 23 from overflow page	27,534,610		27,534,610	36,042,063
2399. Totals (Lines 2301 through 2303 plus 2398) (Line 23 above)	715,856,703	39,949,858	675,906,747	715,420,301

LIABILITIES, SURPLUS AND OTHER FUNDS

	1 Current Year	2 Prior Year
1. Losses (Part 2A, Line 26, Column 6)	12,580,697,955	12,004,676,358
2. Reinsurance payable on paid losses and loss adjustment expenses (Schedule F, Part 1, Column 6)	78,374,442	92,048,626
3. Loss adjustment expenses (Part 2A, Line 36, Column 6)	2,545,218,983	2,498,675,656
4. Commissions payable, contingent commissions and other similar charges	119,822,389	93,083,893
5. Other expenses (including losses, losses and fees)	234,822,784	300,823,585
6. Taxes, licenses and fees (excluding federal and foreign income taxes)	109,208,453	298,823,744
7.1 Current federal and foreign income taxes (including \$ 0 on realized capital gains (losses))		30,696,136
7.2 Net deferred tax liability		
8. Borrowed money \$ 0 and interest thereon \$ 0		905,212
9. Unearned premiums (Part 1A, Line 30, Column 6) (after deducting unearned premiums for ceded reinsurance of \$ 2,125,447,198 and including warranty reserves of \$ 0)	3,283,042,806	3,320,119,872
10. Advance premiums	43,867,917	63,012,854
11. Dividends declared and on-pact:		
11.1 Stockholders		
11.2 Policyholders	1,800,778	1,139,898
12. Ceded reinsurance premiums payable (net of ceding commissions)	717,189,249	650,466,245
13. Funds held by company under reinsurance treaties (Schedule F, Part 3, Column 10)	1,746,663,198	1,807,274,694
14. Amounts withheld or retained by company for account of others	666,497,197	465,703,129
15. Reserves and items not allocated		
16. Provisions for reinsurance (Schedule F, Part 7)	69,876,166	73,287,401
17. Net adjustments in assets and liabilities due to foreign exchange rates		
18. Debts outstanding	294,010,938	297,886,747
19. Payable to parent, subsidiaries and affiliates	35,080,360	72,875,912
20. Payable to securities	39,891,815	15,497,672
21. Liability for amounts held under unsecured plans		
22. Capital notes \$ 0 and interest thereon \$ 0		
23. Aggregate write-ins for liabilities	(202,891,368)	(478,583,630)
24. Total liabilities excluding protected cell liabilities (Lines 1 through 23)	22,338,883,621	22,215,656,786
25. Protected cell liabilities		
26. Total liabilities (Lines 24 and 25)	22,338,883,621	22,215,656,786
27. Aggregate write-ins for special surplus funds	1,200,000,480	957,821,671
28. Common capital stock	10,000,000	10,000,000
29. Preferred capital stock		
30. Aggregate write-ins for other than special surplus funds	1,250,000	1,250,000
31. Surplus notes	795,347,894	652,074,580
32. Gross paid in and contributed surplus	6,436,272,283	6,335,272,283
33. Unassigned funds (surplus)	4,040,814,478	2,135,213,474
34. Less treasury stock, at cost:		
34.1 0 shares common (value included in Line 28 \$ 0)		
34.2 0 shares preferred (value included in Line 28 \$ 0)		
35. Surplus as regards policyholders (Lines 27 to 33, less 34) (Page 4, Line 29)	12,491,502,915	10,334,732,418
36. Totals (Page 2, Line 26, Col. 3)	34,830,436,536	32,549,788,186

DETAILS OF WRITE-IN LINES		
2301. Amounts held under unsecured plans	651,634,174	551,897,180
2302. Other liabilities	410,875,368	426,687,450
2303. Collateral held for securities loaned	279,831,199	119,822,705
2305. Summary of remaining write-ins for Lines 23 from overflow page	(1,645,002,349)	(1,605,357,809)
2309. Totals (Lines 2301 through 2303 plus 2305) (Line 23 above)	(202,891,368)	(478,583,630)
2701. Special surplus from reinsurance	843,721,894	667,821,671
2702. GSAP10R incremental change	341,246,806	
2703.		
2704. Summary of remaining write-ins for Line 27 from overflow page		
2709. Totals (Lines 2701 through 2703 plus 2704) (Line 27 above)	1,200,000,480	957,821,671
3001. Common stock	1,250,000	1,250,000
3002.		
3003.		
3005. Summary of remaining write-ins for Line 30 from overflow page		
3009. Totals (Lines 3001 through 3003 plus 3005) (Line 30 above)	1,250,000	1,250,000

State of Massachusetts
 County of Suffolk

The officers of this reporting entity being duly sworn, each depose and say that they are the described officers of said reporting entity, and that on the reporting period stated above, all of the herein described assets were the absolute property of the said reporting entity, free and clear from any liens or claims thereon, except as herein stated, and that this statement, together with related exhibits, schedules and explanatory footnotes contained, accurate or intended to, in a full and true statement of all the assets and liabilities and of the condition and affairs of the said reporting entity as of the reporting period stated above, and of its income and deductions thereon for the period stated, and have been compiled in accordance with the NAIC Annual Statement Instructions and Accounting Practices and Procedures manual except to the extent that (1) state law may differ; or, (2) that state rules or regulations require differences in reporting and related to accounting practices and procedures according to the laws of their jurisdiction, knowledge and belief, respectively. Furthermore, the scope of this statement by the described officers also includes the related corresponding electronic filing with the NAIC, when required, the true and correct (except for remaining differences due to electronic filing) of the enclosed statement. The electronic filing may be requested by various regulations in that or in addition to the enclosed statement.

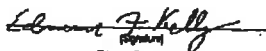
 Edmund Francis Kelly
 Chairman of the Board, President & CEO
 (Title)

 David L. Long
 Vice President & Secretary
 (Title)

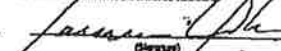
 Laurence Harry Scott Tabb
 Senior Vice President & Treasurer
 (Title)

Subscribed and sworn to (or affirmed) before me on this 14th day of February, 2009, by 



a. Is this an original filing? (X) Yes [] No
 b. If not:
 1. State the attachment number
 2. Date filed
 3. Number of pages attached

THIS POWER OF ATTORNEY IS NOT VALID UNLESS IT IS PRINTED ON RED BACKGROUND.

This Power of Attorney limits the acts of those named herein, and they have no authority to bind the Company except in the manner and to the extent herein stated.

LIBERTY MUTUAL INSURANCE COMPANY
BOSTON, MASSACHUSETTS
POWER OF ATTORNEY

KNOW ALL PERSONS BY THESE PRESENTS: That Liberty Mutual Insurance Company (the "Company"), a Massachusetts stock insurance company, pursuant to and by authority of the By-law and Authorization hereinafter set forth, does hereby name, constitute and appoint SANDRA K. WOLF, ALICE MCLAUGHLIN, MARY R. MCKEE, SHERRYANNE M. DEPIRRO, MARIA L. SPADACCINI, ALL OF THE CITY OF WOODCLIFF LAKE, STATE OF NEW JERSEY.....

, each individually if there be more than one named, its true and lawful attorney-in-fact to make, execute, seal, acknowledge and deliver, for and on its behalf as surety and as its act and deed, any and all undertakings, bonds, recognizances and other surety obligations in the penal sum not exceeding FIVE HUNDRED MILLION AND 00/100***** DOLLARS (\$ 500,000,000.00*****) each, and the execution of such undertakings, bonds, recognizances and other surety obligations, in pursuance of these presents, shall be as binding upon the Company as if they had been duly signed by the president and attested by the secretary of the Company in their own proper persons.

That this power is made and executed pursuant to and by authority of the following By-law and Authorization:

ARTICLE XIII - Execution of Contracts: Section 5. Surety Bonds and Undertakings.

Any officer of the Company authorized for that purpose in writing by the chairman or the president, and subject to such limitations as the chairman or the president may prescribe, shall appoint such attorneys-in-fact, as may be necessary to act in behalf of the Company to make, execute, seal, acknowledge and deliver as surety any and all undertakings, bonds, recognizances and other surety obligations. Such attorneys-in-fact, subject to the limitations set forth in their respective powers of attorney, shall have full power to bind the Company by their signature and execution of any such instruments and to attach thereto the seal of the Company. When so executed such instruments shall be as binding as if signed by the president and attested by the secretary.

By the following instrument the chairman or the president has authorized the officer or other official named therein to appoint attorneys-in-fact:

Pursuant to Article XIII, Section 5 of the By-Laws, Garnet W. Elliott, Assistant Secretary of Liberty Mutual Insurance Company, is hereby authorized to appoint such attorneys-in-fact as may be necessary to act in behalf of the Company to make, execute, seal, acknowledge and deliver as surety any and all undertakings, bonds, recognizances and other surety obligations.

That the By-law and the Authorization set forth above are true copies thereof and are now in full force and effect.

IN WITNESS WHEREOF, this Power of Attorney has been subscribed by an authorized officer or official of the Company and the corporate seal of Liberty Mutual Insurance Company has been affixed thereto in Plymouth Meeting, Pennsylvania this 22nd day of September, 2010.

LIBERTY MUTUAL INSURANCE COMPANY



By Garnet W. Elliott, Assistant Secretary

COMMONWEALTH OF PENNSYLVANIA ss
COUNTY OF MONTGOMERY

On this 22nd day of September, 2010, before me, a Notary Public, personally came Garnet W. Elliott, to me known, and acknowledged that he is an Assistant Secretary of Liberty Mutual Insurance Company; that he knows the seal of said corporation; and that he executed the above Power of Attorney and affixed the corporate seal of Liberty Mutual Insurance Company thereto with the authority and at the direction of said corporation.

IN TESTIMONY WHEREOF, I have hereunto subscribed my name and affixed my notarial seal at Plymouth Meeting, Pennsylvania, on the day and year first above written.



COMMONWEALTH OF PENNSYLVANIA
Notarial Seal
Teresa Pastella, Notary Public
Plymouth Twp., Montgomery County
My Commission Expires March 28, 2013
Member, Pennsylvania Association of Notaries

By Teresa Pastella, Notary Public

CERTIFICATE

I, the undersigned, Assistant Secretary of Liberty Mutual Insurance Company, do hereby certify that the original power of attorney of which the foregoing is a full, true and correct copy, is in full force and effect on the date of this certificate; and I do further certify that the officer or official who executed the said power of attorney is an Assistant Secretary specially authorized by the chairman or the president to appoint attorneys-in-fact as provided in Article XIII, Section 5 of the By-laws of Liberty Mutual Insurance Company.

This certificate and the above power of attorney may be signed by facsimile or mechanically reproduced signatures under and by authority of the following vote of the board of directors of Liberty Mutual Insurance Company at a meeting duly called and held on the 12th day of March, 1980.

VOTED that the facsimile or mechanically reproduced signature of any assistant secretary of the company, wherever appearing upon a certified copy of any power of attorney issued by the company in connection with surety bonds, shall be valid and binding upon the company with the same force and effect as though manually affixed.

IN TESTIMONY WHEREOF, I have hereunto subscribed my name and affixed the corporate seal of the said company, this 4th day of November, 2010.



By David M. Carey, Assistant Secretary

Not valid for mortgage, note, loan, letter of credit, bank deposit, currency rate, interest rate or residual value guarantees.

To confirm the validity of this Power of Attorney call 1-610-832-8240 between 9:00 am and 4:30 pm EST on any business day.

CORPORATE ACKNOWLEDGMENT

Form 152

STATE OF NEW JERSEY

COUNTY OF BERGEN

On this 4TH day of NOVEMBER, 2010, before me personally came ALICE McLAUGHLIN to me known, who, being by me duly sworn, did depose and say that she/he resides in NUTLEY, NEW JERSEY that she/he is the ATTORNEY IN FACT of THE CONTINENTAL INSURANCE COMPANY the corporation described in and which executed the above instrument that she/he knows the seal of said corporation; that the seal affixed to said instrument is such corporate seal; that it was so affixed by order of the Board of Directors of said corporation, and that she/he signed her/his name thereto by like order.

(SEAL)



Maria L. Spadaccini, Notary Public

MARIA L. SPADACCINI
NOTARY PUBLIC OF NEW JERSEY
COMMISSION EXPIRES
MARCH 6, 2013

CNA

THE CONTINENTAL INSURANCE COMPANY
STATEMENT OF NET ADMITTED ASSETS AND LIABILITIES
December 31, 2009

ASSETS:

Cash	\$	2,171,540
Cash equivalents		780,361,330
Short-term investments (principally U.S. government obligations)		476,403,554
United States government obligations		20,618,137
Other public bonds		563,806,324
Industrial and miscellaneous bonds		1,134,444,387
Preferred stocks		0
Common stocks of affiliated companies		235,325,677
Other common stocks		549,621
Real estate		0
Premiums and agents' balances in course of collection		115,928,476
Premiums, agents balances and installments booked but deferred and not yet due		55,245,085
Accrued retrospective premiums		0
Investment income due and accrued		14,427,558
Other assets		406,127,195
Admitted assets	\$	3,805,408,884

LIABILITIES:

Unearned premium reserve	\$	0
Reserve for loss and loss adjustment expense		15,971,162
Reserve for taxes, licenses and fees (including federal income taxes)		44,376,938
Other liabilities		2,203,451,802
Total liabilities		2,263,799,902

SURPLUS:

Capital paid up (\$5.00 par value)		
Shares authorized: 50,000,000 issued: 10,713,272		53,566,360
Gross paid in and contributed surplus		1,423,436,994
Surplus		64,605,628
Surplus as regards policyholders		1,541,608,982
Total	\$	3,805,408,884

State of Illinois)
) ss
County of Cook)

On this 2nd day of April, 2010, before me came Amy Adams, known to me personally to be the Vice President of Continental Insurance Company being fully sworn, certify and attest that the foregoing statement is a true and correct statement of the assets and liabilities of the said company as of the date shown in the statement.

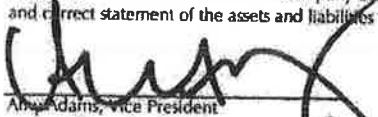
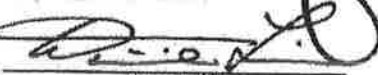
Amy Adams, Vice President

Notary Public



POWER OF ATTORNEY APPOINTING INDIVIDUAL ATTORNEY-IN-FACT

Know All Men By These Presents, That The Continental Insurance Company, a Pennsylvania insurance company, is a duly organized and existing insurance company having its principal office in the City of Chicago, and State of Illinois, and that it does by virtue of the signature and seal herein affixed hereby make, constitute and appoint

Alice Mc Laughlin, Sandra K Wolf, Mary R Mc Kee, Sherryanne M De Pirro, Individually

of Woodcliff Lake, NJ, its true and lawful Attorney(s)-in-Fact with full power and authority hereby conferred to sign, seal and execute for and on its behalf bonds, undertakings and other obligatory instruments of similar nature

- In Unlimited Amounts -

and to bind them thereby as fully and to the same extent as if such instruments were signed by a duly authorized officer of the insurance company and all the acts of said Attorney, pursuant to the authority hereby given is hereby ratified and confirmed.

This Power of Attorney is made and executed pursuant to and by authority of the By-Law and Resolutions, printed on the reverse hereof, duly adopted, as indicated, by the Board of Directors of the insurance company.

In Witness Whereof, The Continental Insurance Company has caused these presents to be signed by its Senior Vice President and its corporate seal to be hereto affixed on this 22nd day of February, 2010.



The Continental Insurance Company

Jacquelyne M. Belcastro
Jacquelyne M. Belcastro Senior Vice President

State of Illinois, County of Cook, ss:

On this 22nd day of February, 2010, before me personally came Jacquelyne M. Belcastro to me known, who, being by me duly sworn, did depose and say: that she resides in the City of Chicago, State of Illinois; that she is a Senior Vice President of The Continental Insurance Company, a Pennsylvania insurance company, described in and which executed the above instrument; that she knows the seal of said insurance company; that the seal affixed to the said instrument is such corporate seal; that it was so affixed pursuant to authority given by the Board of Directors of said insurance company and that she signed her name thereto pursuant to like authority, and acknowledges same to be the act and deed of said insurance company.



My Commission Expires September 17, 2013

Eliza Price
Eliza Price Notary Public

CERTIFICATE

I, Mary A. Ribikawskis, Assistant Secretary of The Continental Insurance Company, a Pennsylvania insurance company, do hereby certify that the Power of Attorney herein above set forth is still in force, and further certify that the By-Law and Resolution of the Board of Directors of the insurance company printed on the reverse hereof is still in force. In testimony whereof I have hereunto subscribed my name and affixed the seal of the said insurance company this 4th day of November, 2010.



The Continental Insurance Company

Mary A. Ribikawskis
Mary A. Ribikawskis Assistant Secretary

Authorizing By-Laws and Resolutions

ADOPTED BY THE BOARD OF DIRECTORS OF THE CONTINENTAL INSURANCE COMPANY:

This Power of Attorney is made and executed pursuant to and by authority of the following By-Law duly adopted by the Board of Directors of the company.

“Article VI-Execution of Documents

Section 3. Appointment of Attorney-in-Fact. The Chairman of the Board of Directors, the President or any Executive or Senior Vice President may, from time to time, appoint by written certificates attorneys-in-fact to act in behalf of the Company in the execution of policies of insurance, bonds, undertakings and other obligatory instruments of like nature. Such attorneys-in-fact, subject to the limitations set forth in their respective certificates of authority shall have full power to bind the Company by their signature and execution of any such instruments and to attach the seal of the Company thereto. The Chairman of the Board of Directors, the President or any Executive or Senior Vice President or the Board of Directors, may, at any time, revoke all power and authority previously given to any attorney-in-fact.

This Power of Attorney is granted and is signed by facsimile under and by the authority of the following Resolution adopted by the Executive Committee of the Board of Directors of The Continental Insurance Company by unanimous written consent dated the 13th day of January, 1989:

RESOLVED, that the signatures of such officers and the seal of the Company may be affixed to any such Power of Attorney or to any certificate relating thereto by facsimile, and any such Power of Attorney or certificate bearing such facsimile signatures or facsimile seal shall be valid and binding upon the Company when so affixed and in the future with respect to any bond, undertaking or contract of suretyship to which it is attached.”

PAYMENT BOND

(Public Work - Civil Code 3247 et seq.)

The makers of this Bond **Flatiron Electric Group Inc**, as Principal and Original Contractor and _____, a corporation, authorized to issue Surety Bonds in California, as Surety, and this Bond is issued in conjunction with that certain public works contract to be executed between Principal and COUNTY OF RIVERSIDE a public entity, as Owner, for **\$ 239,685.00, Two hundred thirty nine thousand, six hundred eighty five dollars and zero cents**, the total amount payable. THE AMOUNT OF THIS BOND IS ONE HUNDRED PERCENT OF SAID SUM. Said contract is for public work generally consisting of **Countywide Traffic Signal Battery Backup System and LED Modules Improvements Project at Various Locations, Phase-1, Project No. B9-0996..**

The beneficiaries of this Bond are as is stated in 3248 of the Civil Code and requirements and conditions of this Bond are as is set forth in 3248, 3249, 3250 and 3252 of said code. Without notice, Surety consents to extension of time for performance, change in requirements, amount of compensation, or prepayment under said contract.

DATED: _____

Original Contractor – Principal

Surety

By _____

By _____
Its Attorney In Fact

Title _____
(If corporation, affix seal)

(Corporate Seal)

(Corporate Seal)

STATE OF CALIFORNIA
COUNTY OF _____

} ss. SURETY'S ACKNOWLEDGEMENT

On _____ before me, _____ personally appeared, _____, known to me, or proved to me on the basis of satisfactory evidence, to be the person whose name is subscribed to the within instrument and acknowledged to me that he/she executed the same in his/her authorized capacities, and that by his/her signature on the instrument the person, or the entity upon behalf of which the person acted, executed the instrument.

WITNESS my hand and official seal.

Signature of Notary Public

Notary Public (Seal)

Note: This Bond must be executed by both parties with corporate seal affixed for each party. All signatures must be notarized. (Attach acknowledgements).

ATTACHMENT A

BOND NUMBERS:	Travelers	1054393402
	Federal	8219-72-63
	F&D/Zurich	08981746
	Liberty	015030847
	Continental	929504968

Travelers Casualty and Surety Company of America, a Connecticut corporation;
 Federal Insurance Company, an Indiana corporation;
 Fidelity and Deposit Company of Maryland, a Maryland corporation;
 Zurich American Insurance Company, a New York corporation;
 Liberty Mutual Insurance Company, a Massachusetts corporation;
 The Continental Insurance Company, a Pennsylvania Corporation

Travelers Casualty and Surety Company of America – A.M. Best Rating A+ XV
 Construction Services, One Tower Square, Hartford, CT 06183
 Contact: Brien Bialaski, V.P. (860) 277-1914

By: 
 Alice McLaughlin, Attorney-In-Fact
 300 Tice Blvd., Suite 250 North, Woodcliff Lake, NJ 07677 (201) 644-2516

Witness: 
 Maria L. Spadaccini

Federal Insurance Company – A.M. Best Rating A++ XV
 15 Mountain View Road, Warren, NJ 07061
 Contact: Matthew Lubin, Director, National Engineering and Construction Group (908) 903-2461

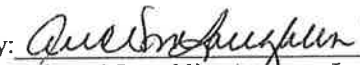
By: 
 Alice McLaughlin, Attorney-In-Fact
 300 Tice Blvd., Suite 250 North, Woodcliff Lake, NJ 07677 (201) 644-2516

Witness: 
 Maria L. Spadaccini

Fidelity and Deposit Company of Maryland – A.M. Best Rating A XV
 1400 American Lane, Schaumburg, IL 60196
 Contact: Thomas McClellan, Sr. Underwriting Officer (410) 559-8730

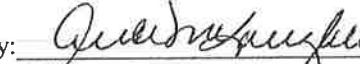
By: 
 Alice McLaughlin, Attorney-In-Fact
 300 Tice Blvd., Suite 250 North, Woodcliff Lake, NJ 07677 (201) 644-2516

Witness: 
 Maria L. Spadaccini

Zurich American Insurance Company – A.M. Best Rating A XV
 1400 American Lane, Schaumburg, IL 60196
 Contact: Thomas McClellan, Sr. Underwriting Officer (410) 559-8730

By: 
 Alice McLaughlin, Attorney-In-Fact
 300 Tice Blvd., Suite 250 North, Woodcliff Lake, NJ 07677 (201) 644-2516

Witness: 
 Maria L. Spadaccini

Liberty Mutual Insurance Company – A.M. Best Rating A XV
 175 Berkeley Street, Boston, MA 02116
 Contact: David D. Roberts, Branch Manager (212) 719-7750

By: 
 Alice McLaughlin, Attorney-In-Fact
 300 Tice Blvd., Suite 250 North, Woodcliff Lake, NJ 07677 (201) 644-2516

Witness: 
 Maria L. Spadaccini

The Continental Insurance Company – A.M. Best Rating A XV
 333 S. Wabash Avenue, Chicago, IL 60604
 Contact: John Fullerton, Branch Manager (212) 440-7356

By: 
 Alice McLaughlin, Attorney-In-Fact
 300 Tice Blvd., Suite 250 North, Woodcliff Lake, NJ 07677 (201) 644-2516

Witness: 
 Maria L. Spadaccini

CALIFORNIA ALL-PURPOSE ACKNOWLEDGMENT

State of California

County of Los Angeles

On November 5, 2010 before me, Shawn R. Bradfield, Notary Public
Date Here Insert Name and Title of the Officer (e.g., "Jane Doe, Notary Public")
personally appeared Richard Tesoriero
Name(s) of Signer(s)

who proved to me on the basis of satisfactory evidence to be the person(s) whose name(s) is/are subscribed to the within instrument and acknowledged to me that he/she/they executed the same in his/her/their authorized capacity(ies), and that by his/her/their signature(s) on the instrument the person(s), or the entity upon behalf of which the person(s) acted, executed the instrument.



I certify under PENALTY OF PERJURY under the laws of the State of California that the foregoing paragraph is true and correct.

WITNESS my hand and official seal.

Signature Shawn R. Bradfield
Signature of Notary Public

OPTIONAL

Though the information below is not required by law, it may prove valuable to persons relying on the document and could prevent fraudulent removal and reattachment of this form to another document.

Description of Attached Document

Title or Type of Document: Payment Bond

Document Date: November 4, 2010 Number of Pages: _____

Signer(s) Other Than Named Above: Alice McLaughlin, Attorney-in-Fact

Capacity(ies) Claimed by Signer(s)

Signer's Name: Richard Tesoriero
 Individual
 Corporate Officer – Title(s): Vice President
 Partner – Limited General
 Attorney-in-Fact
 Trustee
 Guardian or Conservator
 Other: _____

Signer's Name: _____
 Individual
 Corporate Officer – Title(s): _____
 Partner – Limited General
 Attorney-in-Fact
 Trustee
 Guardian or Conservator
 Other: _____

Signer Is Representing: Flatiron Electric Group, Inc.

Signer Is Representing: _____

CORPORATE ACKNOWLEDGMENT

Form 152

STATE OF NEW JERSEY

COUNTY OF BERGEN

On this 4TH day of NOVEMBER, 2010, before me personally came ALICE McLAUGHLIN to me known, who, being by me duly sworn, did depose and say that she/he resides in NUTLEY, NEW JERSEY that she/he is the ATTORNEY IN FACT of the TRAVELERS CASUALTY AND SURETY COMPANY OF AMERICA the corporation described in and which executed the above instrument that she/he knows the seal of said corporation; that the seal affixed to said instrument is such corporate seal; that it was so affixed by order of the Board of Directors of said corporation, and that she/he signed her/his name thereto by like order.

(SEAL)



Maria L. Spadaccini, Notary Public

MARIA L. SPADACCINI
NOTARY PUBLIC OF NEW JERSEY
COMMISSION EXPIRES
MARCH 6, 2013

TRAVELERS CASUALTY AND SURETY COMPANY OF AMERICA

HARTFORD, CONNECTICUT 06183

FINANCIAL STATEMENT AS OF DECEMBER 31, 2009

CAPITAL STOCK \$ 6,480,000

ASSETS		LIABILITIES & SURPLUS	
CASH & INVESTED CASH	\$ 91,652,774	UNEARNED PREMIUMS	\$ 836,517,654
BONDS	3,673,368,648	LOSSES	889,279,087
INVESTMENT INCOME DUE AND ACCRUED	51,425,446	LOSS ADJUSTMENT EXPENSES	391,664,338
PREMIUM BALANCES	183,801,015	COMMISSIONS	\$9,630,568
NET DEFERRED TAX ASSET	72,285,733	TAXES, LICENSES AND FEES	59,474,472
REINSURANCE RECOVERABLE	4,839,080	OTHER EXPENSES	31,736,727
REINSURANCE RECEIVABLE INTERCOMPANY	247,774,291	FUNDS HELD UNDER REINSURANCE TREATIES	101,203,705
OTHER ASSETS	6,728,714	CURRENT FEDERAL AND FOREIGN INCOME TAXES	6,951,413
		REMITTANCES AND ITEMS NOT ALLOCATED	49,208,988
		AMOUNTS WITHHELD / RETAINED BY COMPANY FOR OTHERS	47,770,200
		RETROACTIVE REINSURANCE RESERVE	3,174,786
		POLICYHOLDER DIVIDENDS	6,825,721
		PROVISION FOR REINSURANCE	7,950,503
		CEDED REINSURANCE NET PREMIUMS PAYABLE	(47,012,192)
		PAYABLE TO PARENT, SUBSIDIARIES AND AFFILIATES	60,758,201
		OTHER ACCRUED EXPENSES AND LIABILITIES	1,322,861
		TOTAL LIABILITIES	\$ 2,494,857,039
		CAPITAL STOCK	\$ 6,480,000
		PAID IN SURPLUS	433,603,760
		OTHER SURPLUS	1,396,564,901
		TOTAL SURPLUS TO POLICYHOLDERS	\$ 1,836,648,661
TOTAL ASSETS	\$ 4,331,705,701	TOTAL LIABILITIES & SURPLUS	\$ 4,331,705,701

STATE OF CONNECTICUT)
 COUNTY OF HARTFORD) SS,
 CITY OF HARTFORD)

MICHAEL J. DOODY, BEING DULY SWORN, SAYS THAT HE IS SECOND VICE PRESIDENT, OF TRAVELERS CASUALTY AND SURETY COMPANY OF AMERICA, AND THAT TO THE BEST OF HIS KNOWLEDGE AND BELIEF, THE FOREGOING IS A TRUE AND CORRECT STATEMENT OF THE FINANCIAL CONDITION OF SAID COMPANY AS OF THE 31st DAY OF DECEMBER, 2009.



Michael J. Doody
 SECOND VICE PRESIDENT

[Signature]
 NOTARY PUBLIC -- MY COMMISSION EXPIRES 11/30/2012

SUBSCRIBED AND SWORN TO BEFORE ME THIS
 15th DAY OF APRIL, 2010



POWER OF ATTORNEY

Farmington Casualty Company
Fidelity and Guaranty Insurance Company
Fidelity and Guaranty Insurance Underwriters, Inc.
St. Paul Fire and Marine Insurance Company
St. Paul Guardian Insurance Company

St. Paul Mercury Insurance Company
Travelers Casualty and Surety Company
Travelers Casualty and Surety Company of America
United States Fidelity and Guaranty Company

Attorney-In Fact No. 222859

Certificate No. 003903457

KNOW ALL MEN BY THESE PRESENTS: That St. Paul Fire and Marine Insurance Company, St. Paul Guardian Insurance Company and St. Paul Mercury Insurance Company are corporations duly organized under the laws of the State of Minnesota, that Farmington Casualty Company, Travelers Casualty and Surety Company, and Travelers Casualty and Surety Company of America are corporations duly organized under the laws of the State of Connecticut, that United States Fidelity and Guaranty Company is a corporation duly organized under the laws of the State of Maryland, that Fidelity and Guaranty Insurance Company is a corporation duly organized under the laws of the State of Iowa, and that Fidelity and Guaranty Insurance Underwriters, Inc., is a corporation duly organized under the laws of the State of Wisconsin (herein collectively called the "Companies"), and that the Companies do hereby make, constitute and appoint

Sandra K. Wolf, Alice McLaughlin, Mary R. McKee, Sherryanne M. DePirro, and Maria L. Spadaccini

of the City of Woodcliff Lake, State of New Jersey, their true and lawful Attorney(s)-in-Fact, each in their separate capacity if more than one is named above, to sign, execute, seal and acknowledge any and all bonds, recognizances, conditional undertakings and other writings obligatory in the nature thereof on behalf of the Companies in their business of guaranteeing the fidelity of persons, guaranteeing the performance of contracts and executing or guaranteeing bonds and undertakings required or permitted in any actions or proceedings allowed by law.

IN WITNESS WHEREOF, the Companies have caused this instrument to be signed and their corporate seals to be hereto affixed, this 28th day of September, 2010.

Farmington Casualty Company
Fidelity and Guaranty Insurance Company
Fidelity and Guaranty Insurance Underwriters, Inc.
St. Paul Fire and Marine Insurance Company
St. Paul Guardian Insurance Company

St. Paul Mercury Insurance Company
Travelers Casualty and Surety Company
Travelers Casualty and Surety Company of America
United States Fidelity and Guaranty Company



State of Connecticut
City of Hartford ss.

By: [Signature]
George W. Thompson, Senior Vice President

On this the 28th day of September, 2010, before me personally appeared George W. Thompson, who acknowledged himself to be the Senior Vice President of Farmington Casualty Company, Fidelity and Guaranty Insurance Company, Fidelity and Guaranty Insurance Underwriters, Inc., St. Paul Fire and Marine Insurance Company, St. Paul Guardian Insurance Company, St. Paul Mercury Insurance Company, Travelers Casualty and Surety Company, Travelers Casualty and Surety Company of America, and United States Fidelity and Guaranty Company, and that he, as such, being authorized so to do, executed the foregoing instrument for the purposes therein contained by signing on behalf of the corporations by himself as a duly authorized officer.

In Witness Whereof, I hereunto set my hand and official seal. My Commission expires the 30th day of June, 2011.



[Signature]
Marie C. Tetreault, Notary Public

This Power of Attorney is granted under and by the authority of the following resolutions adopted by the Boards of Directors of Farmington Casualty Company, Fidelity and Guaranty Insurance Company, Fidelity and Guaranty Insurance Underwriters, Inc., St. Paul Fire and Marine Insurance Company, St. Paul Guardian Insurance Company, St. Paul Mercury Insurance Company, Travelers Casualty and Surety Company, Travelers Casualty and Surety Company of America, and United States Fidelity and Guaranty Company, which resolutions are now in full force and effect, reading as follows:

RESOLVED, that the Chairman, the President, any Vice Chairman, any Executive Vice President, any Senior Vice President, any Vice President, any Second Vice President, the Treasurer, any Assistant Treasurer, the Corporate Secretary or any Assistant Secretary may appoint Attorneys-in-Fact and Agents to act for and on behalf of the Company and may give such appointee such authority as his or her certificate of authority may prescribe to sign with the Company's name and seal with the Company's seal bonds, recognizances, contracts of indemnity, and other writings obligatory in the nature of a bond, recognizance, or conditional undertaking, and any of said officers or the Board of Directors at any time may remove any such appointee and revoke the power given him or her; and it is

FURTHER RESOLVED, that the Chairman, the President, any Vice Chairman, any Executive Vice President, any Senior Vice President or any Vice President may delegate all or any part of the foregoing authority to one or more officers or employees of this Company, provided that each such delegation is in writing and a copy thereof is filed in the office of the Secretary; and it is

FURTHER RESOLVED, that any bond, recognizance, contract of indemnity, or writing obligatory in the nature of a bond, recognizance, or conditional undertaking shall be valid and binding upon the Company when (a) signed by the President, any Vice Chairman, any Executive Vice President, any Senior Vice President or any Vice President, any Second Vice President, the Treasurer, any Assistant Treasurer, the Corporate Secretary or any Assistant Secretary and duly attested and sealed with the Company's seal by a Secretary or Assistant Secretary; or (b) duly executed (under seal, if required) by one or more Attorneys-in-Fact and Agents pursuant to the power prescribed in his or her certificate or their certificates of authority or by one or more Company officers pursuant to a written delegation of authority; and it is

FURTHER RESOLVED, that the signature of each of the following officers: President, any Executive Vice President, any Senior Vice President, any Vice President, any Assistant Vice President, any Secretary, any Assistant Secretary, and the seal of the Company may be affixed by facsimile to any Power of Attorney or to any certificate relating thereto appointing Resident Vice Presidents, Resident Assistant Secretaries or Attorneys-in-Fact for purposes only of executing and attesting bonds and undertakings and other writings obligatory in the nature thereof, and any such Power of Attorney or certificate bearing such facsimile signature or facsimile seal shall be valid and binding upon the Company and any such power so executed and certified by such facsimile signature and facsimile seal shall be valid and binding on the Company in the future with respect to any bond or understanding to which it is attached.

I, Kori M. Johanson, the undersigned, Assistant Secretary, of Farmington Casualty Company, Fidelity and Guaranty Insurance Company, Fidelity and Guaranty Insurance Underwriters, Inc., St. Paul Fire and Marine Insurance Company, St. Paul Guardian Insurance Company, St. Paul Mercury Insurance Company, Travelers Casualty and Surety Company, Travelers Casualty and Surety Company of America, and United States Fidelity and Guaranty Company do hereby certify that the above and foregoing is a true and correct copy of the Power of Attorney executed by said Companies, which is in full force and effect and has not been revoked.

IN TESTIMONY WHEREOF, I have hereunto set my hand and affixed the seals of said Companies this 4th day of November, 2010.

WARNING: THIS POWER OF ATTORNEY IS INVALID WITHOUT THE RED BORDER

Kori M. Johanson, Assistant Secretary



To verify the authenticity of this Power of Attorney, call 1-800-421-3880 or contact us at www.travelersbond.com. Please refer to the Attorney-In-Fact number, the above-named individuals and the details of the bond to which the power is attached.

CORPORATE ACKNOWLEDGMENT

Form 152

STATE OF NEW JERSEY

COUNTY OF BERGEN

On this 4TH day of NOVEMBER, 2010, before me personally came ALICE McLAUGHLIN to me known, who, being by me duly sworn, did depose and say that she/he resides in NUTLEY, NEW JERSEY that she/he is the ATTORNEY IN FACT of the FEDERAL INSURANCE COMPANY the corporation described in and which executed the above instrument that she/he knows the seal of said corporation; that the seal affixed to said instrument is such corporate seal; that it was so affixed by order of the Board of Directors of said corporation, and that she/he signed her/his name thereto by like order.

(SEAL)



Maria L. Spadaccini, Notary Public

MARIA L. SPADACCINI
NOTARY PUBLIC OF NEW JERSEY
COMMISSION EXPIRES
MARCH 6, 2013

FEDERAL INSURANCE COMPANY

STATEMENT OF ASSETS, LIABILITIES AND SURPLUS TO POLICYHOLDERS

Statutory Basis

DECEMBER 31, 2009

(in thousands of dollars)

<i>ASSETS</i>		<i>LIABILITIES AND SURPLUS TO POLICYHOLDERS</i>	
Cash and Short Term Investments.....	\$ 257,630	Outstanding Losses and Loss Expenses	\$ 11,900,150
United States Government, State and Municipal Bonds.....	11,077,454	Unearned Premiums.....	3,345,760
Other Bonds.....	4,042,056	Reinsurance Premiums Payable	322,875
Stocks	778,949	Provision for Reinsurance	79,993
Other Invested Assets.....	<u>1,758,696</u>	Other Liabilities.....	<u>717,789</u>
TOTAL INVESTMENTS.....	<u>17,914,785</u>	TOTAL LIABILITIES	<u>16,366,567</u>
Investments in Affiliates:		Special Surplus Funds.....	176,031
Chubb Investment Holdings, Inc.....	2,881,003	Capital Stock	20,980
Pacific Indemnity Company.....	2,200,172	Paid-In Surplus.....	3,106,809
Chubb Insurance Investment Holdings Ltd. ..	1,539,334	Unassigned Funds.....	<u>11,017,701</u>
Executive Risk Indemnity Inc.....	1,078,688		
CC Canada Holdings Ltd.....	607,555	SURPLUS TO POLICYHOLDERS.....	<u>14,321,521</u>
Great Northern Insurance Company	453,227		
Chubb European Investment Holdings SLP .	271,092		
Chubb Insurance Company of Australia ...	255,177		
Vigilant Insurance Company.....	176,625		
Other Affiliates	349,088		
Premiums Receivable.....	1,458,416	TOTAL LIABILITIES AND SURPLUS TO POLICYHOLDERS.....	<u>\$ 30,688,088</u>
Other Assets	<u>1,502,926</u>		
TOTAL ADMITTED ASSETS	<u>\$ 30,688,088</u>		

Investments are valued in accordance with requirements of the National Association of Insurance Commissioners.
Investments valued at \$448,814,488 are deposited with government authorities as required by law.

State, County & City of New York, — ss:

Yvonne Baker, Assistant Secretary _____ of the Federal Insurance Company
being duly sworn, deposes and says that the foregoing Statement of Assets, Liabilities and Surplus to Policyholders of said
Federal Insurance Company on December 31, 2009 is true and correct and is a true abstract of the Annual Statement of said
Company as filed with the Secretary of the Treasury of the United States for the 12 months ending December 31, 2009.

Subscribed and sworn to before me
this



Notary Public

DOROTHY M. BAKER
Notary Public, State of New York
No. 31-4804994
Qualified in New York County
Commission Expires Sept. 14, 2013

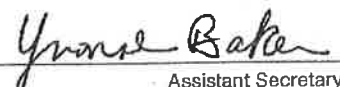

Assistant Secretary



**Chubb
Surety**

**POWER
OF
ATTORNEY**

**Federal Insurance Company
Vigilant Insurance Company
Pacific Indemnity Company**

**Attn: Surety Department
15 Mountain View Road
Warren, NJ 07059**

Know All by These Presents, That FEDERAL INSURANCE COMPANY, an Indiana corporation, VIGILANT INSURANCE COMPANY, a New York corporation, and PACIFIC INDEMNITY COMPANY, a Wisconsin corporation, do each hereby constitute and appoint Sherryanne M. DePirro, Mary R. McKee, Alice McLaughlin, Maria L. Spadaccini and Sandra K. Wolf of Woodcliff Lake, New Jersey

each as their true and lawful Attorney- in- Fact to execute under such designation in their names and to affix their corporate seals to and deliver for and on their behalf as surety thereon or otherwise, bonds and undertakings and other writings obligatory in the nature thereof (other than bail bonds) given or executed in the course of business, and any instruments amending or altering the same, and consents to the modification or alteration of any instrument referred to in said bonds or obligations.

In Witness Whereof, said FEDERAL INSURANCE COMPANY, VIGILANT INSURANCE COMPANY, and PACIFIC INDEMNITY COMPANY have each executed and attested these presents and affixed their corporate seals on this **22nd** day of **September, 2010**.

Kenneth C. Wendel, Assistant Secretary

Richard A. Ciullo, Vice President

STATE OF NEW JERSEY
County of Somerset

ss.

On this **22nd** day of **September, 2010** before me, a Notary Public of New Jersey, personally came Kenneth C. Wendel, to me known to be Assistant Secretary of FEDERAL INSURANCE COMPANY, VIGILANT INSURANCE COMPANY, and PACIFIC INDEMNITY COMPANY, the companies which executed the foregoing Power of Attorney, and the said Kenneth C. Wendel, being by me duly sworn, did depose and say that he is Assistant Secretary of FEDERAL INSURANCE COMPANY, VIGILANT INSURANCE COMPANY, and PACIFIC INDEMNITY COMPANY and knows the corporate seals thereof, that the seals affixed to the foregoing Power of Attorney are such corporate seals and were thereto affixed by authority of the By- Laws of said Companies; and that he signed said Power of Attorney as Assistant Secretary of said Companies by like authority; and that he is acquainted with Richard A. Ciullo, and knows him to be Vice President of said Companies; and that the signature of Richard A. Ciullo, subscribed to said Power of Attorney is in the genuine handwriting of Richard A. Ciullo, and was thereto subscribed by authority of said By- Laws and in deponent's presence.

Notarial Seal



KATHERINE J. ADELAAR
NOTARY PUBLIC OF NEW JERSEY
No. 2316685
Commission Expires July 15, 2014

Notary Public

CERTIFICATION

Extract from the By- Laws of FEDERAL INSURANCE COMPANY, VIGILANT INSURANCE COMPANY, and PACIFIC INDEMNITY COMPANY:

"All powers of attorney for and on behalf of the Company may and shall be executed in the name and on behalf of the Company, either by the Chairman or the President or a Vice President or an Assistant Vice President, jointly with the Secretary or an Assistant Secretary, under their respective designations. The signature of such officers may be engraved, printed or lithographed. The signature of each of the following officers: Chairman, President, any Vice President, any Assistant Vice President, any Secretary, any Assistant Secretary and the seal of the Company may be affixed by facsimile to any power of attorney or to any certificate relating thereto appointing Assistant Secretaries or Attorneys- in- Fact for purposes only of executing and attesting bonds and undertakings and other writings obligatory in the nature thereof, and any such power of attorney or certificate bearing such facsimile signature or facsimile seal shall be valid and binding upon the Company and any such power so executed and certified by such facsimile signature and facsimile seal shall be valid and binding upon the Company with respect to any bond or undertaking to which it is attached."

I, Kenneth C. Wendel, Assistant Secretary of FEDERAL INSURANCE COMPANY, VIGILANT INSURANCE COMPANY, and PACIFIC INDEMNITY COMPANY (the "Companies") do hereby certify that

- (i) the foregoing extract of the By- Laws of the Companies is true and correct,
- (ii) the Companies are duly licensed and authorized to transact surety business in all 50 of the United States of America and the District of Columbia and are authorized by the U.S. Treasury Department; further, Federal and Vigilant are licensed in Puerto Rico and the U.S. Virgin Islands, and Federal is licensed in American Samoa, Guam, and each of the Provinces of Canada except Prince Edward Island; and
- (iii) the foregoing Power of Attorney is true, correct and in full force and effect.

Given under my hand and seals of said Companies at Warren, NJ this 4th of November, 2010.



Kenneth C. Wendel, Assistant Secretary

IN THE EVENT YOU WISH TO NOTIFY US OF A CLAIM, VERIFY THE AUTHENTICITY OF THIS BOND OR NOTIFY US OF ANY OTHER MATTER, PLEASE CONTACT US AT ADDRESS LISTED ABOVE, OR BY Telephone (908) 903- 3493 Fax (908) 903- 3656 e-mail: surety@chubb.com

CORPORATE ACKNOWLEDGMENT

Form 152

STATE OF NEW JERSEY

COUNTY OF BERGEN

On this 4TH day of NOVEMBER, 2010, before me personally came ALICE McLAUGHLIN to me known, who, being by me duly sworn, did depose and say that she/he resides in NUTLEY, NEW JERSEY that she/he is the ATTORNEY IN FACT of the FIDELITY AND DEPOSIT COMPANY OF MARYLAND the corporation described in and which executed the above instrument that she/he knows the seal of said corporation; that the seal affixed to said instrument is such corporate seal; that it was so affixed by order of the Board of Directors of said corporation, and that she/he signed her/his name thereto by like order.

(SEAL)



Maria L. Spadaccini, Notary Public

MARIA L. SPADACCINI
NOTARY PUBLIC OF NEW JERSEY
COMMISSION EXPIRES
MARCH 6, 2013

FIDELITY AND DEPOSIT COMPANY
OF MARYLAND
3910 KESWICK ROAD, BALTIMORE, MD 21211-2226

Statement of Financial Condition
As Of December 31, 2009

ASSETS	
Bonds	\$ 156,584,995
Stocks	22,537,672
Cash and Short Term Investments	9,719,598
Reinsurance Recoverable	9,347,241
Other Accounts Receivable	51,052,264
TOTAL ADMITTED ASSETS	\$ 249,241,769

LIABILITIES, SURPLUS AND OTHER FUNDS	
Reserve for Taxes and Expenses	\$ 76,835
Ceded Reinsurance Premiums Payable	58,237,612
Securities Lending Collateral Liability	5,511,875
TOTAL LIABILITIES	\$ 63,826,322
Capital Stock, Paid Up	\$ 5,000,000
Surplus	180,415,448
Surplus as regards Policyholders	185,415,447
TOTAL	\$ 249,241,769

Securities carried at \$38,385,957 in the above statement are deposited as required by law.

Securities carried on the basis prescribed by the National Association of Insurance Commissioners. On the basis of December 31, 2009 market quotations for all bonds and stocks owned, the Company's total admitted assets would be \$247,657,513 and surplus as regards policyholders \$186,999,703.

I, DENNIS F. KERRIGAN, Corporate Secretary of the FIDELITY AND DEPOSIT COMPANY OF MARYLAND, do hereby certify that the foregoing statement is a correct exhibit of the assets and liabilities of the said Company on the 31st day of December, 2009.

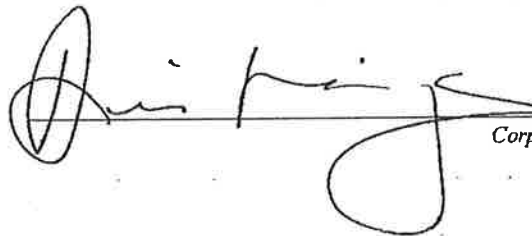

 Corporate Secretary

State of Illinois }
City of Schaumburg } SS:

Subscribed and sworn to, before me, a Notary Public of the State of Illinois, in the City of Schaumburg, this 15th day of March, 2010.



 Notary Public

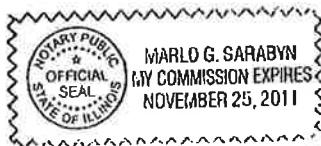

Power of Attorney
FIDELITY AND DEPOSIT COMPANY OF MARYLAND

KNOW ALL MEN BY THESE PRESENTS: That the FIDELITY AND DEPOSIT COMPANY OF MARYLAND, a corporation of the State of Maryland, by WILLIAM J. MILLS, Vice President, and GERALD F. HALEY, Assistant Secretary, in pursuance of authority granted by Article VI, Section 2, of the By-Laws of said Company, which are set forth on the reverse side hereof and are hereby certified to be in full force and effect on the date hereof does hereby nominate, constitute and appoint **Sandra K. WOLF, Alice MCLAUGHLIN, Mary R. MCKEE and Sherryanne M. DEPIRRO, all of Woodcliff Lake, New Jersey, EACH** its true and lawful agent and Attorney-in-Fact to make, execute, seal and deliver, for, and on its behalf as surety, and as its act and deed, ~~any and all bonds and undertakings~~, and the execution of such bonds or undertakings in pursuance of these presents shall be as binding upon said Company, as fully and amply, to all intents and purposes, as if they had been duly executed and acknowledged by the regularly elected officers of the Company at its office in Baltimore, Md. in their own proper persons. This power of attorney revokes that issued on behalf of Sandra K. WOLF, Alice MCLAUGHLIN, Mary R. MCKEE, Sherryanne DEPIRRO, dated March 28, 2008.

The said Assistant Secretary does hereby certify that the extract set forth on the reverse side hereof is a true copy of Article VI, Section 2, of the By-Laws of said Company, and is now in force.

IN WITNESS WHEREOF, the said Vice-President and Assistant Secretary have hereunto subscribed their names and affixed the Corporate Seal of the said FIDELITY AND DEPOSIT COMPANY OF MARYLAND, this 22nd day of April, A.D. 2008.

ATTEST:

FIDELITY AND DEPOSIT COMPANY OF MARYLAND



Gerald F. Haley

By:

William J. Mills

Gerald F. Haley Assistant Secretary

William J. Mills

William J. Mills Vice President

State of Maryland }
City of Baltimore } ss:

On this 22nd day of April, A.D. 2008, before the subscriber, a Notary Public of the State of Maryland, duly commissioned and qualified, came WILLIAM J. MILLS, Vice President, and GERALD F. HALEY, Assistant Secretary of the FIDELITY AND DEPOSIT COMPANY OF MARYLAND, to me personally known to be the individuals and officers described in and who executed the preceding instrument, and they each acknowledged the execution of the same, and being by me duly sworn, severally and each for himself depose and saith, that they are the said officers of the Company aforesaid, and that the seal affixed to the preceding instrument is the Corporate Seal of said Company, and that the said Corporate Seal and their signatures as such officers were duly affixed and subscribed to the said instrument by the authority and direction of the said Corporation.

IN TESTIMONY WHEREOF, I have hereunto set my hand and affixed my Official Seal the day and year first above written.



Maria D. Adamski

Maria D. Adamski

Notary Public

My Commission Expires: July 8, 2011

EXTRACT FROM BY-LAWS OF FIDELITY AND DEPOSIT COMPANY OF MARYLAND

“Article VI, Section 2. The Chairman of the Board, or the President, or any Executive Vice-President, or any of the Senior Vice-Presidents or Vice-Presidents specially authorized so to do by the Board of Directors or by the Executive Committee, shall have power, by and with the concurrence of the Secretary or any one of the Assistant Secretaries, to appoint Resident Vice-Presidents, Assistant Vice-Presidents and Attorneys-in-Fact as the business of the Company may require, or to authorize any person or persons to execute on behalf of the Company any bonds, undertakings, recognizances, stipulations, policies, contracts, agreements, deeds, and releases and assignments of judgements, decrees, mortgages and instruments in the nature of mortgages,...and to affix the seal of the Company thereto.”

CERTIFICATE

I, the undersigned, Assistant Secretary of the FIDELITY AND DEPOSIT COMPANY OF MARYLAND, do hereby certify that the foregoing Power of Attorney is still in full force and effect on the date of this certificate; and I do further certify that the Vice-President who executed the said Power of Attorney was one of the additional Vice-Presidents specially authorized by the Board of Directors to appoint any Attorney-in-Fact as provided in Article VI, Section 2, of the By-Laws of the FIDELITY AND DEPOSIT COMPANY OF MARYLAND.

This Power of Attorney and Certificate may be signed by facsimile under and by authority of the following resolution of the Board of Directors of the FIDELITY AND DEPOSIT COMPANY OF MARYLAND at a meeting duly called and held on the 10th day of May, 1990.

RESOLVED: "That the facsimile or mechanically reproduced seal of the company and facsimile or mechanically reproduced signature of any Vice-President, Secretary, or Assistant Secretary of the Company, whether made heretofore or hereafter, wherever appearing upon a certified copy of any power of attorney issued by the Company, shall be valid and binding upon the Company with the same force and effect as though manually affixed."

IN TESTIMONY WHEREOF, I have hereunto subscribed my name and affixed the corporate seal of the said Company,

this 4th day of November, 2010.

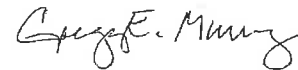

Assistant Secretary

CORPORATE ACKNOWLEDGMENT

Form 152

STATE OF NEW JERSEY

COUNTY OF BERGEN

On this 4TH day of NOVEMBER, 2010, before me personally came ALICE McLAUGHLIN to me known, who, being by me duly sworn, did depose and say that she/he resides in NUTLEY, NEW JERSEY that she/he is the ATTORNEY IN FACT of the ZURICH AMERICAN INSURANCE COMPANY the corporation described in and which executed the above instrument that she/he knows the seal of said corporation; that the seal affixed to said instrument is such corporate seal; that it was so affixed by order of the Board of Directors of said corporation, and that she/he signed her/his name thereto by like order.

(SEAL)



Maria L. Spadaccini, Notary Public

MARIA L. SPADACCINI
NOTARY PUBLIC OF NEW JERSEY
COMMISSION EXPIRES
MARCH 6, 2013

ZURICH AMERICAN INSURANCE COMPANY
COMPARATIVE BALANCE SHEET
ONE LIBERTY PLAZA, 165 BROADWAY, 32nd FLOOR, NEW YORK, NY 10006
As of December 31, 2009 and December 31, 2008

	12/31/2009	12/31/2008
Assets		
Bonds	\$ 18,856,255,156	\$ 18,080,264,654
Preferred Stock	983,952	70,077,341
Common Stock	2,414,799,006	2,523,871,473
Real Estate	-	25,457,836
Other Invested Assets	1,955,583,185	1,699,943,998
Short-term Investments	442,083,498	117,588,071
Receivable for securities	924,864	8,050,472
Cash and cash equivalents	81,175,295	66,140,854
Employees Trust for Deferred Compensation Plan	115,265,399	92,484,754
Total Cash and Invested Assets	\$ 23,867,070,354	\$ 22,683,879,453
Premiums Receivable	\$ 3,789,891,423	\$ 4,504,508,588
Funds Held with Reinsurers	17,543,464	18,761,471
Reinsurance Recoverable	334,417,233	859,700,252
Accrued Investment Income	153,168,265	149,763,601
Federal Income Tax Recoverable	938,076,547	583,896,990
Due from Affiliates	270,234,627	178,313,325
Other Assets	565,343,140	655,646,493
Total Assets	\$ 29,935,745,054	\$ 29,634,470,173
Liabilities and Policyholders' Surplus		
Liabilities:		
Loss and LAE Reserves	\$ 14,457,673,205	\$ 14,645,410,951
Unearned Premium Reserve	4,286,806,531	4,602,631,426
Funds Held with Reinsurers	249,802,186	248,918,770
Loss In Course of Payment	416,324,234	460,126,217
Commission Reserve	154,104,769	155,353,168
Federal Income Tax Payable	24,130,322	16,936,764
Remittances and Items Unallocated	152,534,594	135,262,884
Payable to parent, subs and affiliates	304,648,750	199,894,895
Provision for Reinsurance	74,859,513	95,167,954
Ceded Reinsurance Premiums Payable	62,782,469	605,799,518
Securities Lending Collateral Liability	328,068,754	102,593,522
Other Liabilities	2,006,859,109	2,126,543,703
Total Liabilities	\$ 22,518,594,436	\$ 23,394,639,772
Policyholders' Surplus:		
Common Capital Stock	\$ 5,000,000	\$ 5,000,000
Paid-In and Contributed Surplus	4,394,131,321	4,394,131,321
Surplus Notes	1,883,000,000	1,883,000,000
Special Surplus Retroactive Reinsurance	101,720,000	73,761,000
Change in Net Deferred Tax Asset	348,814,703	-
Cumulative Unrealized Gain	(74,742,079)	(316,593,413)
Dividends Undeclared	-	222,129
Loss Portfolio Transfer Account	-	-
Unassigned Surplus	759,226,673	200,309,364
Total Policyholders' Surplus	\$ 7,417,150,618	\$ 6,239,830,401
Total Liabilities and Policyholders' Surplus	\$ 29,935,745,054	\$ 29,634,470,173

I, Dennis F. Kerrigan, Corporate Secretary of ZURICH AMERICAN INSURANCE COMPANY do hereby certify that the foregoing statement is a correct exhibit of the assets and liabilities of the said Company, on the 31st day of December, 2009, according to the best of my information, knowledge and belief.



Corporate Secretary

State of Illinois
County of Cook

} SS:

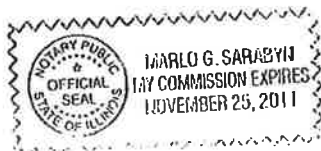
Subscribed and sworn to, before me, a Notary Public of the State of Illinois, in the City of Schaumburg, this 15th day of March, 2010.

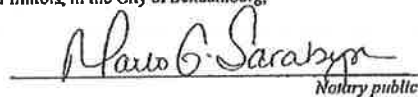

Notary public

ZURICH AMERICAN INSURANCE COMPANY

POWER OF ATTORNEY

KNOW ALL MEN BY THESE PRESENTS, that the ZURICH AMERICAN INSURANCE COMPANY, a corporation created by and existing under the laws of the State of New York does hereby nominate, constitute and appoint Sandra K. WOLF, Alice MCLAUGHLIN, Mary R. MCKEE and Sherryanne M. DEPIRRO, all of Woodcliff Lake, New Jersey, EACH its true and lawful Attorneys-In-Fact with power and authority hereby conferred to sign, seal, and execute in its behalf, during the period beginning with the date of issuance of this power, : any and all bonds and undertakings, recognizances or other written obligations in the nature thereof, and to bind ZURICH AMERICAN INSURANCE COMPANY thereby, and all of the acts of said Attorney[s]-in-Fact pursuant to these presents are hereby ratified and confirmed . This Power of Attorney is made and executed pursuant to and by the authority of the following By-Law duly adopted by the Board of Directors of the Company which By-Law has not been amended or rescinded.

Article VI, Section 5. "...The President or a Vice President in a written instrument attested by a Secretary or an Assistant Secretary may appoint any person Attorney-In-Fact with authority to execute surety bonds on behalf of the Company and other formal underwriting contracts in reference thereto and reinsurance agreements relating to individual policies and bonds of all kinds and attach the corporate seal. Any such officers may revoke the powers granted to any Attorney-In-Fact."

This Power of Attorney is signed and sealed by facsimile under and by the authority of the following Resolution adopted by the Board of Directors of the ZURICH AMERICAN INSURANCE COMPANY by unanimous consent in lieu of a special meeting dated December 15, 1998

" RESOLVED, that the signature of the President or a Vice President and the attesting signature of a Secretary or an Assistant Secretary and the seal of the Company may be affixed by facsimile on any Power of Attorney pursuant to Article VI, Section 5 of the By-Laws, and the signature of a Secretary or an Assistant Secretary and the seal of the Company may be affixed by facsimile to any certificate of any such power. Any such power or any certificate thereof with such facsimile signature and seal shall be valid and binding on the Company. Furthermore, such power so executed, sealed and certified by certificate so executed and sealed shall, with respect to any bond or undertaking to which it is attached, shall continue to be valid and binding on the Company."

IN WITNESS WHEREOF, the ZURICH AMERICAN INSURANCE COMPANY has caused these presents to be executed in its name and on its behalf and its Corporate Seal to be hereunto affixed and attested by its officers thereunto duly authorized, this 22nd day of April, A.D. 2008. This power of attorney revokes that issued on behalf of Sandra K. WOLF, Alice MCLAUGHLIN, Mary R. MCKEE, Sherryanne DEPIRRO, dated March 28, 2008.



ZURICH AMERICAN INSURANCE COMPANY

Gerald F. Haley

Frank E. Martin Jr.

STATE OF MARYLAND }
CITY OF BALTIMORE }

SS:

Gerald F. Haley

Secretary

By:

Frank E. Martin Jr.

Vice President

On the 22nd day of April, A.D. 2008, before the subscriber, a Notary Public of the State of Maryland, duly commissioned and qualified, came the above named Vice President and Secretary of ZURICH AMERICAN INSURANCE COMPANY, to me personally known to be the individuals and officers described in and who executed the preceding instrument and they each acknowledged the execution of the same and being by me duly sworn, they severally and each for himself deposed and said that they respectively hold the offices in said Corporation as indicated, that the Seal affixed to the preceding instrument is the Corporate Seal of said Corporation, and that the said Corporate Seal, and their respective signature as such officers, were duly affixed and subscribed to the said instrument pursuant to all due corporate authorization.

IN WITNESS WHEREOF, I have hereunto set my hand and affixed my Official Seal the day and year first above.



Maria D. Alamb

Notary Public

My Commission Expires: July 8, 2011

This Power of Attorney limits the acts of those named therein to the bonds and undertaking specifically named therein, and they have no authority to bind the Company except in the manner and to the extent herein stated.

CERTIFICATE

I, the undersigned, a Secretary of the ZURICH AMERICAN INSURANCE COMPANY, do hereby certify that the foregoing Power of Attorney is still in full force and effect, and further certify that Article VI, Section 5 of the By-Laws of the Company and the Resolution of the Board of Directors set forth in said Power of Attorney are still in force.

IN TESTIMONY WHEREOF I have hereto subscribed my name and affixed the seal of said Company

Gregory E. Murray

the 4th day of November, 2010

Gregory E. Murray

Secretary



CORPORATE ACKNOWLEDGMENT

Form 152

STATE OF NEW JERSEY

COUNTY OF BERGEN

On this 4TH day of NOVEMBER, 2010, before me personally came ALICE McLAUGHLIN to me known, who, being by me duly sworn, did depose and say that she/he resides in NUTLEY, NEW JERSEY that she/he is the ATTORNEY IN FACT of the LIBERTY MUTUAL INSURANCE COMPANY the corporation described in and which executed the above instrument that she/he knows the seal of said corporation; that the seal affixed to said instrument is such corporate seal; that it was so affixed by order of the Board of Directors of said corporation, and that she/he signed her/his name thereto by like order.

(SEAL)

Maria L. Spadaccini, Notary Public

MARIA L. SPADACCINI
NOTARY PUBLIC OF NEW JERSEY
COMMISSION EXPIRES
MARCH 6, 2013

ASSETS

	Current Year			Prior Year
	1	2	3	4
	Assets	Nonadmitted Assets	Net Admitted Assets (Cols. 1 - 2)	Net Admitted Assets
1. Bonds (Schedule D)	11,425,766,895		11,425,766,895	11,057,669,501
2. Stocks (Schedule D):				
2.1 Preferred stocks	762,976,318		762,976,318	757,319,706
2.2 Common stocks	9,135,552,552		9,135,552,552	7,570,471,320
3. Mortgage loans on real estate (Schedule B):				
3.1 First liens	519,022,709		519,022,709	548,091,252
3.2 Other than first liens				
4. Real estate (Schedule A):				
4.1 Properties occupied by the company (less \$ 0 encumbrances)	337,179,530		337,179,530	425,989,166
4.2 Properties held for the production of income (less \$ 0 encumbrances)	978,262		978,262	1,039,982
4.3 Properties held for sale (less \$ 0 encumbrances)				
5. Cash (\$ 399,502,555, Schedule E - Part 1), cash equivalents (\$ 82,179,054, Schedule E - Part 2), and short-term investments (\$ 352,850,853, Schedule DA)	824,332,462		824,332,462	1,349,306,516
6. Contract loans (including \$ 0 premium notes)				
7. Other invested assets (Schedule BA)	5,771,150,576	206,157	5,770,944,419	5,331,343,213
8. Receivables for securities	12,271,548		12,271,548	2,859,056
9. Aggregate write-ins for invested assets				
10. Subtotals, cash and invested assets (Lines 1 to 9)	28,609,230,852	206,157	28,609,024,695	26,944,088,712
11. Title plants less \$ 0 charged off (for Title Insurers only)				
12. Investment income due and accrued	133,129,777		133,129,777	140,188,757
13. Premiums and considerations:				
13.1 Uncollected premiums and agents' balances in the course of collection	993,284,743	14,732,220	978,552,523	1,071,899,224
13.2 Deferred premiums, agents' balances and installments booked but deferred and not yet due (including \$ 0 earned but unbilled premiums)	1,519,460,073		1,519,460,073	1,594,927,150
13.3 Accrued retrospective premiums	366,445,348	36,644,635	329,800,713	383,694,097
14. Reinsurance:				
14.1 Amounts recoverable from reinsurers	593,195,507		593,195,507	560,300,803
14.2 Funds held by or deposited with reinsured companies	13,527,020		13,527,020	17,294,633
14.3 Other amounts receivable under reinsurance contracts				
15. Amounts receivable relating to uninsured plans	21,095	11,418	9,677	175,315
16.1 Current federal and foreign income tax recoverable and interest thereon	313,172,066		313,172,066	
16.2 Net deferred tax asset	1,188,251,090	164,925,490	1,023,325,600	846,790,256
17. Guaranty funds receivable or on deposit	33,248,467		33,248,467	32,559,328
18. Electronic data processing equipment and software	319,102,379	257,221,814	61,880,565	60,291,004
19. Furniture and equipment, including health care delivery assets (\$ 0)	126,014,225	126,014,225		
20. Net adjustment in assets and liabilities due to foreign exchange rates				
21. Receivables from parent, subsidiaries and affiliates	346,223,617	610	346,223,007	312,158,606
22. Health care (\$ 0) and other amounts receivable				
23. Aggregate write-ins for other than invested assets	715,856,703	39,949,956	675,906,747	715,420,301
24. Total assets excluding Separate Accounts, Segregated Accounts and Protected Cell Accounts (Lines 10 to 23)	35,470,142,980	639,706,425	34,830,436,555	32,549,788,186
25. From Separate Accounts, Segregated Accounts and Protected Cell Accounts				
26. Total (Lines 24 and 25)	35,470,142,980	639,706,425	34,830,436,555	32,549,788,186

DETAILS OF WRITE-IN LINES			
0901.			
0902.			
0903.			
0998. Summary of remaining write-ins for Line 09 from overflow page			
0999. Totals (Lines 0901 through 0903 plus 0906) (Line 9 above)			
2301. Cash Surrender Value Life Insurance	383,284,396		383,284,396
2302. Amounts receivable under high deductible policies	172,319,200	115,094	172,204,146
2303. Other assets	132,718,497	39,834,902	92,883,596
2398. Summary of remaining write-ins for Line 23 from overflow page	27,534,610		27,534,610
2399. Totals (Lines 2301 through 2303 plus 2398) (Line 23 above)	715,856,703	39,949,956	675,906,747

LIABILITIES, SURPLUS AND OTHER FUNDS

	1 Current Year	2 Prior Year
1. Losses (Part 2A, Line 35, Column 8)	12,880,897,955	12,894,676,388
2. Reinsurance payable on paid losses and loss adjustment expenses (Schedule F, Part 1, Column 8)	78,374,442	82,948,426
3. Loss adjustment expenses (Part 2A, Line 35, Column 9)	2,545,218,983	2,488,475,659
4. Commissions payable, contingent commissions and other similar charges	118,822,389	95,083,893
5. Other expenses (excluding losses, losses and fees)	234,829,784	340,923,555
6. Taxes, licenses and fees (excluding federal and foreign income taxes)	188,208,453	238,824,744
7.1 Current federal and foreign income taxes (including \$ 0 on realized capital gains (losses))		38,105,135
7.2 Net deferred tax liability		
8. Borrowed money \$ 0 and interest thereon 0		605,212
9. Unearned premiums (Part 1A, Line 36, Column 9) (after deducting unearned premiums for taxed reinsurance of \$ 2,195,447,180 and including warranty reserves of \$ 0)	3,283,042,806	3,320,119,872
10. Advance premium	48,887,917	80,012,664
11. Dividends declared and unpaid:		
11.1 Stockholders		
11.2 Policyholders	1,600,778	1,138,898
12. Ceded reinsurance premiums payable (net of ceding commissions)	717,189,249	680,465,245
13. Funds held by company under reinsurance treaties (Schedule F, Part 3, Column 19)	1,746,993,198	1,807,214,084
14. Amounts withheld or retained by company for account of others	665,697,197	465,703,129
15. Reserves and items not allocated		
16. Provisions for reinsurance (Schedule F, Part 7)	89,878,168	73,887,801
17. Net adjustments in assets and liabilities due to foreign exchange rates		
18. Items outstanding	294,010,988	292,825,747
19. Payable to parent, subsidiaries and affiliates	35,080,282	72,875,912
20. Payable for securities	58,521,815	15,457,672
21. Liability for amounts held under reinsured plans		
22. Capital notes \$ 0 and interest thereon 0		
23. Aggregate write-ins for liabilities	(202,881,388)	(478,583,030)
24. Total liabilities excluding protected cell liabilities (Lines 1 through 23)	22,338,883,820	22,215,055,788
25. Protected cell liabilities		
26. Total liabilities (Lines 24 and 25)	22,338,883,820	22,215,055,788
27. Aggregate write-ins for special surplus funds	1,209,098,480	957,821,871
28. Common capital stock	10,000,000	10,000,000
29. Preferred capital stock		
30. Aggregate write-ins for other than special surplus funds	1,250,000	1,250,000
31. Surplus notes	755,347,884	682,074,980
32. Gross paid in and contributed surplus	5,435,272,283	6,335,272,283
33. Unassigned funds (surplus)	4,040,814,478	2,438,213,674
34. Less treasury stock, at cost:		
34.1 0 shares common (value included in Line 28 \$ 0)		
34.2 0 shares preferred (value included in Line 28 \$ 0)		
35. Surplus as regards policyholders (Lines 27 to 33, less 34) (Page 4, Line 39)	12,491,469,915	10,334,732,418
36. Totals (Page 2, Line 28, Col. 3)	34,830,436,535	32,549,788,186

DETAILS OF WRITE-IN LINES		
2301. Amounts held under reinsured plans	651,634,174	581,887,188
2302. Other liabilities	410,475,889	424,947,878
2303. Collateral held for securities loaned	279,821,188	110,828,705
2304. Summary of remaining write-ins for Line 23 from overflow page	(1,645,032,348)	(1,896,357,809)
2305. Totals (Lines 2301 through 2304 plus 2305) (Line 23 above)	(202,881,388)	(478,583,030)
2701. Board surplus from reinsurance reinsurance	952,731,854	957,821,871
2702. SSAPTOR incremental change	241,349,028	
2703.		
2704. Summary of remaining write-ins for Line 27 from overflow page		
2705. Totals (Lines 2701 through 2703 plus 2704) (Line 27 above)	1,209,098,480	957,821,871
3001. Quarterly funds	1,250,000	1,250,000
3002.		
3003.		
3004. Summary of remaining write-ins for Line 30 from overflow page		
3005. Totals (Lines 3001 through 3003 plus 3004) (Line 30 above)	1,250,000	1,250,000

Date of Massachusetts
City of Boston

The officers of this reporting entity being duly sworn, each depose and say that they are the described officers of said reporting entity, and that on the reporting period stated above, all of the herein described items were the absolute property of the said reporting entity, free and clear from any liens or claims thereon, except as herein stated, and that this statement, together with related exhibits, schedules and appendices thereto contained, annexed or referred to, is a full and true disclosure of the assets and liabilities and of the condition and status of the said reporting entity as of the reporting period stated above, and of its income and deductions thereon for the period stated, and have been completed in accordance with the NAIC Annual Statement Instructions and Accounting Practices and Procedures rules of effect in the relevant state; (1) none has any effect; or, (2) that state law or regulations require disclosures in reporting not related to accounting practices and procedures, according to the best of their knowledge, knowledge and belief, respectively. Furthermore, to the scope of this statement by the described officers also includes the related source posting electronic filing with the NAIC, when required, that have a primary impact for financial disclosure due to electronic filing of the enclosed statement. This abstract filing may be requested by various regulators in lieu of or in addition to the enclosed statement.

Edmond F. Kelly (Signature) Daniel P. Long (Signature) James H. Smith (Signature)
Edmond Francis Kelly (Printed Name) Daniel P. Long (Printed Name) James Henry Smith (Printed Name)
1. Chairman of the Board President & CEO 2. Vice President & Secretary 3. Senior Vice President & Treasurer
(Title) (Title) (Title)

Subscribed and sworn to (as affirmed) before me on this 1st day of February, 2010, by Edmond F. Kelly



a. Is this an original filing? Yes | No
b. If not: 1. State the document number
2. Date filed
3. Number of pages attached

THIS POWER OF ATTORNEY IS NOT VALID UNLESS IT IS PRINTED ON RED BACKGROUND.

This Power of Attorney limits the acts of those named herein, and they have no authority to bind the Company except in the manner and to the extent herein stated.

LIBERTY MUTUAL INSURANCE COMPANY
BOSTON, MASSACHUSETTS
POWER OF ATTORNEY

KNOW ALL PERSONS BY THESE PRESENTS: That Liberty Mutual Insurance Company (the "Company"), a Massachusetts stock insurance company, pursuant to and by authority of the By-law and Authorization hereinafter set forth, does hereby name, constitute and appoint SANDRA K. WOLF, ALICE MCLAUGHLIN, MARY R. MCKEE, SHERRYANNE M. DEPIRRO, MARIA L. SPADACCINI, ALL OF THE CITY OF WOODCLIFF LAKE, STATE OF NEW JERSEY.....

, each individually if there be more than one named, its true and lawful attorney-in-fact to make, execute, seal, acknowledge and deliver, for and on its behalf as surety and as its act and deed, any and all undertakings, bonds, recognizances and other surety obligations in the penal sum not exceeding FIVE HUNDRED MILLION AND 00/100***** DOLLARS (\$ 500,000,000.00*****) each, and the execution of such undertakings, bonds, recognizances and other surety obligations, in pursuance of these presents, shall be as binding upon the Company as if they had been duly signed by the president and attested by the secretary of the Company in their own proper persons.

That this power is made and executed pursuant to and by authority of the following By-law and Authorization:

ARTICLE XIII - Execution of Contracts: Section 5. Surety Bonds and Undertakings.

Any officer of the Company authorized for that purpose in writing by the chairman or the president, and subject to such limitations as the chairman or the president may prescribe, shall appoint such attorneys-in-fact, as may be necessary to act in behalf of the Company to make, execute, seal, acknowledge and deliver as surety any and all undertakings, bonds, recognizances and other surety obligations. Such attorneys-in-fact, subject to the limitations set forth in their respective powers of attorney, shall have full power to bind the Company by their signature and execution of any such instruments and to attach thereto the seal of the Company. When so executed such instruments shall be as binding as if signed by the president and attested by the secretary.

By the following instrument the chairman or the president has authorized the officer or other official named therein to appoint attorneys-in-fact:

Pursuant to Article XIII, Section 5 of the By-Laws, Garnet W. Elliott, Assistant Secretary of Liberty Mutual Insurance Company, is hereby authorized to appoint such attorneys-in-fact as may be necessary to act in behalf of the Company to make, execute, seal, acknowledge and deliver as surety any and all undertakings, bonds, recognizances and other surety obligations.

That the By-law and the Authorization set forth above are true copies thereof and are now in full force and effect.

IN WITNESS WHEREOF, this Power of Attorney has been subscribed by an authorized officer or official of the Company and the corporate seal of Liberty Mutual Insurance Company has been affixed thereto in Plymouth Meeting, Pennsylvania this 22nd day of September, 2010.

LIBERTY MUTUAL INSURANCE COMPANY

By Garnet W. Elliott, Assistant Secretary



COMMONWEALTH OF PENNSYLVANIA ss
COUNTY OF MONTGOMERY

On this 22nd day of September, 2010, before me, a Notary Public, personally came Garnet W. Elliott, to me known, and acknowledged that he is an Assistant Secretary of Liberty Mutual Insurance Company; that he knows the seal of said corporation; and that he executed the above Power of Attorney and affixed the corporate seal of Liberty Mutual Insurance Company thereto with the authority and at the direction of said corporation.

IN TESTIMONY WHEREOF, I have hereunto subscribed my name and affixed my notarial seal at Plymouth Meeting, Pennsylvania, on the day and year first above written.



COMMONWEALTH OF PENNSYLVANIA
Notarial Seal
Teresa Pastella, Notary Public
Plymouth Twp., Montgomery County
My Commission Expires March 28, 2013
Member, Pennsylvania Association of Notaries

By Teresa Pastella, Notary Public

CERTIFICATE

I, the undersigned, Assistant Secretary of Liberty Mutual Insurance Company, do hereby certify that the original power of attorney of which the foregoing is a full, true and correct copy, is in full force and effect on the date of this certificate; and I do further certify that the officer or official who executed the said power of attorney is an Assistant Secretary specially authorized by the chairman or the president to appoint attorneys-in-fact as provided in Article XIII, Section 5 of the By-laws of Liberty Mutual Insurance Company.

This certificate and the above power of attorney may be signed by facsimile or mechanically reproduced signatures under and by authority of the following vote of the board of directors of Liberty Mutual Insurance Company at a meeting duly called and held on the 12th day of March, 1980.

VOTED that the facsimile or mechanically reproduced signature of any assistant secretary of the company, wherever appearing upon a certified copy of any power of attorney issued by the company in connection with surety bonds, shall be valid and binding upon the company with the same force and effect as though manually affixed.

IN TESTIMONY WHEREOF, I have hereunto subscribed my name and affixed the corporate seal of the said company, this 4th day of November, 2010.



By David M. Carey, Assistant Secretary

Not valid for mortgage, note, loan, letter of credit, bank deposit, currency rate, interest rate or residual value guarantees.

To confirm the validity of this Power of Attorney call 1-610-832-8240 between 9:00 am and 4:30 pm EST on any business day.

CORPORATE ACKNOWLEDGMENT

Form 152

STATE OF NEW JERSEY

COUNTY OF BERGEN

On this 4TH day of NOVEMBER, 2010, before me personally came ALICE McLAUGHLIN to me known, who, being by me duly sworn, did depose and say that she/he resides in NUTLEY, NEW JERSEY that she/he is the ATTORNEY IN FACT of THE CONTINENTAL INSURANCE COMPANY the corporation described in and which executed the above instrument that she/he knows the seal of said corporation; that the seal affixed to said instrument is such corporate seal; that it was so affixed by order of the Board of Directors of said corporation, and that she/he signed her/his name thereto by like order.

(SEAL)

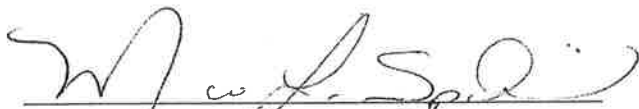

Maria L. Spadaccini, Notary Public

MARIA L. SPADACCINI
NOTARY PUBLIC OF NEW JERSEY
COMMISSION EXPIRES
MARCH 6, 2013

CNA

THE CONTINENTAL INSURANCE COMPANY
STATEMENT OF NET ADMITTED ASSETS AND LIABILITIES
December 31, 2009

ASSETS:

Cash	\$	2,171,540
Cash equivalents		780,361,330
Short-term investments (principally U.S. government obligations)		476,403,554
United States government obligations		20,618,137
Other public bonds		563,806,324
Industrial and miscellaneous bonds		1,134,444,387
Preferred stocks		0
Common stocks of affiliated companies		235,325,677
Other common stocks		549,621
Real estate		0
Premiums and agents' balances in course of collection		115,928,476
Premiums, agents balances and installments booked but deferred and not yet due		55,245,085
Accrued retrospective premiums		0
Investment income due and accrued		14,427,558
Other assets		406,127,195
Admitted assets	\$	3,805,408,884

LIABILITIES:

Unearned premium reserve	\$	0
Reserve for loss and loss adjustment expense		15,971,162
Reserve for taxes, licenses and fees (including federal income taxes)		44,376,938
Other liabilities		2,203,451,802
Total liabilities		2,263,799,902

SURPLUS:

Capital paid up (\$5.00 par value)		
Shares authorized; 50,000,000 issued: 10,713,272		53,566,360
Gross paid in and contributed surplus		1,423,436,994
Surplus		64,605,628
Surplus as regards policyholders		1,541,608,982
Total	\$	3,805,408,884

State of Illinois)
) ss
County of Cook)

On this 2nd day of April, 2010, before me came Amy Adams, known to me personally to be the Vice President of Continental Insurance Company being fully sworn, certify and attest that the foregoing statement is a true and correct statement of the assets and liabilities of the said company as of the date shown in the statement.

Amy Adams, Vice President

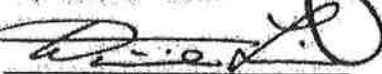
Notary Public



POWER OF ATTORNEY APPOINTING INDIVIDUAL ATTORNEY-IN-FACT

Know All Men By These Presents, That The Continental Insurance Company, a Pennsylvania insurance company, is a duly organized and existing insurance company having its principal office in the City of Chicago, and State of Illinois, and that it does by virtue of the signature and seal herein affixed hereby make, constitute and appoint

Alice Mc Laughlin, Sandra K Wolf, Mary R Mc Kee, Sherryanne M De Pirro, Individually

of Woodcliff Lake, NJ, its true and lawful Attorney(s)-in-Fact with full power and authority hereby conferred to sign, seal and execute for and on its behalf bonds, undertakings and other obligatory instruments of similar nature

- In Unlimited Amounts -

and to bind them thereby as fully and to the same extent as if such instruments were signed by a duly authorized officer of the insurance company and all the acts of said Attorney, pursuant to the authority hereby given is hereby ratified and confirmed.

This Power of Attorney is made and executed pursuant to and by authority of the By-Law and Resolutions, printed on the reverse hereof, duly adopted, as indicated, by the Board of Directors of the insurance company.

In Witness Whereof, The Continental Insurance Company has caused these presents to be signed by its Senior Vice President and its corporate seal to be hereto affixed on this 24th day of August, 2010.



The Continental Insurance Company

Jacquelyne M. Belcastro Senior Vice President

State of Illinois, County of Cook, ss:

On this 24th day of August, 2010, before me personally came Jacquelyne M. Belcastro to me known, who, being by me duly sworn, did depose and say: that she resides in the City of Chicago, State of Illinois; that she is a Senior Vice President of The Continental Insurance Company, a Pennsylvania insurance company, described in and which executed the above instrument; that she knows the seal of said insurance company; that the seal affixed to the said instrument is such corporate seal; that it was so affixed pursuant to authority given by the Board of Directors of said insurance company and that she signed her name thereto pursuant to like authority, and acknowledges same to be the act and deed of said insurance company.



My Commission Expires September 17, 2013

Eliza Price Notary Public

CERTIFICATE

I, Mary A. Ribikawskis, Assistant Secretary of The Continental Insurance Company, a Pennsylvania insurance company, do hereby certify that the Power of Attorney herein above set forth is still in force, and further certify that the By-Law and Resolution of the Board of Directors of the insurance company printed on the reverse hereof is still in force. In testimony whereof I have hereunto subscribed my name and affixed the seal of the said insurance company this 4th day of November, 2010.



The Continental Insurance Company

Mary A. Ribikawskis Assistant Secretary

Authorizing By-Laws and Resolutions

ADOPTED BY THE BOARD OF DIRECTORS OF THE CONTINENTAL INSURANCE COMPANY:

This Power of Attorney is made and executed pursuant to and by authority of the following By-Law duly adopted by the Board of Directors of the company.

"Article VI-Execution of Documents

Section 3. Appointment of Attorney-in-Fact. The Chairman of the Board of Directors, the President or any Executive or Senior Vice President may, from time to time, appoint by written certificates attorneys-in-fact to act in behalf of the Company in the execution of policies of insurance, bonds, undertakings and other obligatory instruments of like nature. Such attorneys-in-fact, subject to the limitations set forth in their respective certificates of authority shall have full power to bind the Company by their signature and execution of any such instruments and to attach the seal of the Company thereto. The Chairman of the Board of Directors, the President or any Executive or Senior Vice President or the Board of Directors, may, at any time, revoke all power and authority previously given to any attorney-in-fact.

This Power of Attorney is granted and is signed by facsimile under and by the authority of the following Resolution adopted by the Executive Committee of the Board of Directors of The Continental Insurance Company by unanimous written consent dated the 13th day of January, 1989:

RESOLVED, that the signatures of such officers and the seal of the Company may be affixed to any such Power of Attorney or to any certificate relating thereto by facsimile, and any such Power of Attorney or certificate bearing such facsimile signatures or facsimile seal shall be valid and binding upon the Company when so affixed and in the future with respect to any bond, undertaking or contract of suretyship to which it is attached."



- Company Profile
- Company Search
- Company Search Results
- Company Information
- Old Company Names
- Agent for Service Reference Information
- NAIC Group List
- Lines of Business
- Complaint and Requests for Action Contact Information
- Financial Statements PDF's
 - Annual Statements
 - Quarterly Statements
 - CA Supplements
- Company Complaint
 - Company Performance & Comparison Data
 - Company Enforcement Action
 - Composite Complaints Studies
- Additional Info
 - Find A Company Representative In Your Area
 - View Financial Disclaimer

COMPANY PROFILE

Company Information

TRAVELERS CASUALTY AND SURETY COMPANY OF AMERICA

**ONE TOWER SQUARE, 4MN
HARTFORD, CT 06183
877-872-8737**

Old Company Names	Effective Date
AETNA CASUALTY & SURETY COMPANY OF AMERICA	07/01/1997

back to top

Agent For Service

KAREN HARRIS
C/O CORPORATION SERVICE COMPANY
2730 GATEWAY OAKS DRIVE, SUITE 100
SACRAMENTO CA 95833

back to top

Reference Information

NAIC #:	31194
California Company ID #:	2444-8
Date Authorized in California:	07/31/1981
License Status:	UNLIMITED-NORMAL
Company Type:	Property & Casualty
State of Domicile:	CONNECTICUT

back to top

NAIC Group List

NAIC Group #: 3548 Travelers Grp

back to top

Lines Of Business

The company is authorized to transact business within these lines of insurance. For an explanation of any of these terms, please refer to the glossary.

- AIRCRAFT
- AUTOMOBILE
- BOILER AND MACHINERY
- BURGLARY
- COMMON CARRIER LIABILITY
- CREDIT
- DISABILITY
- FIRE
- LIABILITY
- MARINE
- MISCELLANEOUS
- PLATE GLASS
- SPRINKLER
- SURETY
- TEAM AND VEHICLE
- WORKERS' COMPENSATION

back to top



- Company Profile
- Company Search
- Company Search Results
- Company Information
- Old Company Names
- Agent for Service Reference Information
- NAIC Group List
- Lines of Business
- Complaint and Requests for Action Contact Information
- Financial Statements PDF's
 - Annual Statements
 - Quarterly Statements
 - CA Supplements
- Company Complaint
- Company Performance & Comparison Data
- Company Enforcement Action
- Composite Complaints Studies
- Additional Info
 - Find A Company Representative In Your Area
 - View Financial Disclaimer

COMPANY PROFILE

Company Information

FEDERAL INSURANCE COMPANY
15 MOUNTAIN VIEW ROAD
WARREN, NJ 07061-1615
800-252-4670

Old Company Names

Effective Date

[back to top](#)

Agent For Service

JERE KEPRIOS
 C/O CT CORPORATION SYSTEM
 818 WEST SEVENTH ST
 LOS ANGELES CA 90017

[back to top](#)

Reference Information

NAIC #:	20281
California Company ID #:	0059-6
Date Authorized in California:	12/18/1902
License Status:	UNLIMITED-NORMAL
Company Type:	Property & Casualty
State of Domicile:	INDIANA

[back to top](#)

NAIC Group List

NAIC Group #: 0038 CHUBB & SON INC

[back to top](#)

Lines Of Business

The company is authorized to transact business within these lines of insurance. For an explanation of any of these terms, please refer to the glossary.

- AIRCRAFT
- AUTOMOBILE
- BOILER AND MACHINERY
- BURGLARY
- COMMON-CARRIER LIABILITY
- CREDIT
- DISABILITY
- FIRE
- LIABILITY
- MARINE
- MISCELLANEOUS
- PLATE GLASS
- SPRINKLER
- SURETY
- TEAM AND VEHICLE
- WORKERS' COMPENSATION

[back to top](#)

Complaint and Requests for Action Contact Information



- Company Profile
- Company Search
- Company Search Results
- Company Information
- Old Company Names
- Agent for Service Reference Information
- NAIC Group List
- Lines of Business
- Complaint and Requests for Action Contact Information
- Financial Statements PDF's
- Annual Statements
- Quarterly Statements
- CA Supplements
- Company Complaint
- Company Performance & Comparison Data
- Company Enforcement Action
- Composite Complaints Studies
- Additional Info
- Find A Company Representative In Your Area
- View Financial Disclaimer

COMPANY PROFILE

Company Information

FIDELITY AND DEPOSIT COMPANY OF MARYLAND

1400 AMERICAN LANE, 19TH FLOOR
 SCHUAMBURG, IL 60196-1056
 800-382-2150

Old Company Names

Effective Date

back to top

Agent For Service

KAREN HARRIS
 C/O CORPORATION SERVICE COMPANY
 2730 GATEWAY OAKS DRIVE, SUITE 100
 SACRAMENTO CA 95833

back to top

Reference Information

NAIC #:	39306
California Company ID #:	2479-4
Date Authorized in California:	01/01/1982
License Status:	UNLIMITED-NORMAL
Company Type:	Property & Casualty
State of Domicile:	MARYLAND

back to top

NAIC Group List

NAIC Group #: 0212 ZURICH INS GRP

back to top

Lines Of Business

The company is authorized to transact business within these lines of insurance. For an explanation of any of these terms, please refer to the glossary.

- AIRCRAFT
- AUTOMOBILE
- BOILER AND MACHINERY
- BURGLARY
- CREDIT
- FIRE
- LIABILITY
- MARINE
- MISCELLANEOUS
- PLATE GLASS
- SPRINKLER
- SURETY
- TEAM AND VEHICLE
- WORKERS' COMPENSATION

back to top

Complaint and Requests for Action Contact Information



- Company Profile
- Company Search
- Company Search Results
- Company Information
- Old Company Names
- Agent for Service Reference Information
- NAIC Group List
- Lines of Business
- Complaint and Requests for Action Contact Information
- Financial Statements PDF's
 - Annual Statements
 - Quarterly Statements
 - CA Supplements
- Company Complaint
- Company Performance & Comparison Data
- Company Enforcement Action
- Composite Complaints Studies
- Additional Info
 - Find A Company Representative In Your Area
 - View Financial Disclaimer

COMPANY PROFILE

Company Information

ZURICH AMERICAN INSURANCE COMPANY

**1400 AMERICAN LANE
SCHAUMBURG, IL 60196-1056
800-382-2150**

Old Company Names

Effective Date

[back to top](#)

Agent For Service

KAREN HARRIS
C/O CORPORATION SERVICE COMPANY
2730 GATEWAY OAKS DRIVE, SUITE 100
SACRAMENTO CA 95833

[back to top](#)

Reference Information

NAIC #:	16535
California Company ID #:	4581-5
Date Authorized in California:	01/01/1999
License Status:	UNLIMITED-NORMAL
Company Type:	Property & Casualty
State of Domicile:	NEW YORK

[back to top](#)

NAIC Group List

NAIC Group #: 0212 ZURICH INS GRP

[back to top](#)

Lines Of Business

The company is authorized to transact business within these lines of insurance. For an explanation of any of these terms, please refer to the glossary.

- AIRCRAFT
- AUTOMOBILE
- BOILER AND MACHINERY
- BURGLARY
- COMMON CARRIER LIABILITY
- CREDIT
- DISABILITY
- FIRE
- LIABILITY
- MARINE
- MISCELLANEOUS
- PLATE GLASS
- SPRINKLER
- SURETY
- TEAM AND VEHICLE
- WORKERS' COMPENSATION

[back to top](#)

Complaint and Requests for Action Contact Information



- Company Profile
- Company Search
- Company Search Results
- Company Information
- Old Company Names
- Agent for Service Reference Information
- NAIC Group List
- Lines of Business
- Complaint and Requests for Action Contact Information
- Financial Statements PDF's
- Annual Statements
- Quarterly Statements
- CA Supplements
- Company Complaint
- Company Performance & Comparison Data
- Company Enforcement Action
- Composite Complaints Studies
- Additional Info
- Find A Company Representative In Your Area
- View Financial Disclaimer

COMPANY PROFILE

Company Information

LIBERTY MUTUAL INSURANCE COMPANY

**175 BERKELEY ST
BOSTON, MA 02116
800-262-8238**

Old Company Names

Effective Date

back to top

Agent For Service

KAREN HARRIS
C/O CORPORATION SERVICE COMPANY
2730 GATEWAY OAKS DRIVE, SUITE 100
SACRAMENTO CA 95833

back to top

Reference Information

NAIC #:	23043
California Company ID #:	1022-3
Date Authorized in California:	08/30/1929
License Status:	UNLIMITED-NORMAL
Company Type:	Property & Casualty
State of Domicile:	MASSACHUSETTS

back to top

NAIC Group List

NAIC Group #: 0111 LIBERTY MUT GRP

back to top

Lines Of Business

The company is authorized to transact business within these lines of insurance. For an explanation of any of these terms, please refer to the glossary.

- AIRCRAFT
- AUTOMOBILE
- BOILER AND MACHINERY
- BURGLARY
- COMMON CARRIER LIABILITY
- CREDIT
- DISABILITY
- FIRE
- LIABILITY
- MARINE
- MISCELLANEOUS
- PLATE GLASS
- SPRINKLER
- SURETY
- TEAM AND VEHICLE
- WORKERS' COMPENSATION

back to top

Complaint and Requests for Action Contact Information



- Company Profile
- Company Search
- Company Search Results
- Company Information
- Old Company Names
- Agent for Service Reference Information
- NAIC Group List
- Lines of Business
- Complaint and Requests for Action Contact Information
- Financial Statements PDF's
 - Annual Statements
 - Quarterly Statements
 - CA Supplements
- Company Complaint
- Company Performance & Comparison Data
- Company Enforcement Action
- Composite Complaints Studies
- Additional Info
 - Find A Company Representative In Your Area
 - View Financial Disclaimer

COMPANY PROFILE

Company Information

CONTINENTAL INSURANCE COMPANY (THE)
CNA 333 S. WABASH, 28TH FL.
CHICAGO, IL 60685
800-262-4554

Old Company Names

Effective Date

[back to top](#)

Agent For Service

JERE KEPRIOS
 C/O CT CORPORATION SYSTEM
 818 WEST SEVENTH ST
 LOS ANGELES CA 90017

[back to top](#)

Reference Information

NAIC #:	35289
California Company ID #:	2270-7
Date Authorized in California:	01/01/1978
License Status:	UNLIMITED-NORMAL
Company Type:	Property & Casualty
State of Domicile:	PENNSYLVANIA

[back to top](#)

NAIC Group List

NAIC Group #: 0218 CNA INS GRP

[back to top](#)

Lines Of Business

The company is authorized to transact business within these lines of insurance. For an explanation of any of these terms, please refer to the glossary.

- AIRCRAFT
- AUTOMOBILE
- BOILER AND MACHINERY
- BURGLARY
- COMMON CARRIER LIABILITY
- CREDIT
- DISABILITY
- FIRE
- LIABILITY
- MARINE
- MISCELLANEOUS
- PLATE GLASS
- SPRINKLER
- SURETY
- TEAM AND VEHICLE
- WORKERS' COMPENSATION

[back to top](#)

Complaint and Requests for Action Contact Information

IMPORTANT

If the certificate holder is an **ADDITIONAL INSURED**, the policy(ies) must be endorsed. A statement on this certificate does not confer rights to the certificate holder in lieu of such endorsement(s).

If **SUBROGATION IS WAIVED**, subject to the terms and conditions of the policy, certain policies may require an endorsement. A statement on this certificate does not confer rights to the certificate holder in lieu of such endorsement(s).

DISCLAIMER

The Certificate of Insurance on the reverse side of this form does not constitute a contract between the issuing insurer(s), authorized representative or producer, and the certificate holder, nor does it affirmatively or negatively amend, extend or alter the coverage afforded by the policies listed thereon.

DESCRIPTIONS (Continued from Page 1)

Job #5247

Value: \$239,685.00

The following are Additional Insureds as respects to General Liability but only if required by written contract or written agreement and coverage applies to work performed by the Insured.

The following are Additional Insureds on the Automobile Liability Policy but only to the extent they meet the definition of an insured, which provides in pertinent part that an insured includes anyone liable for the conduct of an insured but only to the extent of that liability.

All coverages, terms, conditions and exclusions of the General Liability and Automobile Liability Policies apply.

The General Liability policy is Primary and Non-Contributory per the terms and conditions if required by written contract. The Workers' Compensation and General Liability policies include a Waiver of Subrogation in favor of the Additional Insureds only if required by written contract.

Additional Insureds:

Riverside County, including its officials, employees, volunteers and representatives

* The following cancellation conditions always apply: - 10 days for Non-Payment of Premium - If policy shown, 30 days for Workers' Compensation for fraud; material misrepresentation; non-payment of premium; other reasons approved by the Commissioner of Insurance.

General Liability Coverage is Primary and Non-Contributory

Waiver of Subrogation applies

Additional Insured – Automatic – Owners, Lessees Or Contractors



Policy No.	Exp. Date of Pol.	Eff. Date of End.	Agency No.	Addl. Prem.	Return Prem.
GLO593970702	06/01/10	06/01/2011			

THIS ENDORSEMENT CHANGES THE POLICY. PLEASE READ IT CAREFULLY.

Named Insured: Flatiron Electric Group, Inc. F/K/A Terno, Inc.
Address (including ZIP Code): 15701 Heron Avenue, La Mirada, CA 90638

This endorsement modifies insurance provided under the:
Commercial General Liability Coverage Part

- A. **Section II – Who Is An Insured** is amended to include as an insured any person or organization who you are required to add as an additional insured on this policy under a written contract or written agreement.
- B. The insurance provided to the additional insured person or organization applies only to "bodily injury", "property damage" or "personal and advertising injury" covered under **SECTION I - Coverage A - Bodily Injury And Property Damage Liability** and **Section I - Coverage B - Personal And Advertising Injury Liability**, but only with respect to liability for "bodily injury", "property damage" or "personal and advertising injury" caused, in whole or in part, by:
 - 1. Your acts or omissions; or
 - 2. The acts or omissions of those acting on your behalf; and resulting directly from:
 - a. Your ongoing operations performed for the additional insured, which is the subject of the written contract or written agreement; or
 - b. "Your work" completed as included in the "products-completed operations hazard", performed for the additional insured, which is the subject of the written contract or written agreement.
- C. However, regardless of the provisions of paragraphs A. and B. above:
 - 1. We will not extend any insurance coverage to any additional insured person or organization:
 - a. That is not provided to you in this policy; or
 - b. That is any broader coverage than you are required to provide to the additional insured person or organization in the written contract or written agreement; and
 - 2. We will not provide Limits of Insurance to any additional insured person or organization that exceed the lower of:
 - a. The Limits of Insurance provided to you in this policy; or
 - b. The Limits of Insurance you are required to provide in the written contract or written agreement.

D. The insurance provided to the additional insured person or organization does not apply to:

"Bodily injury", "property damage" or "personal and advertising injury" arising out of the rendering or failure to render any professional architectural, engineering or surveying services including:

1. The preparing, approving or failing to prepare or approve maps, shop drawings, opinions, reports, surveys, field orders, change orders or drawings and specifications; and
2. Supervisory, inspection, architectural or engineering activities.

E. The additional insured must see to it that:

1. We are notified as soon as practicable of an "occurrence" or offense that may result in a claim;
2. We receive written notice of a claim or "suit" as soon as practicable; and
3. A request for defense and indemnity of the claim or "suit" will promptly be brought against any policy issued by another insurer under which the additional insured may be an insured in any capacity. This provision does not apply to insurance on which the additional insured is a Named Insured, if the written contract or written agreement requires that this coverage be primary and non-contributory.

F. For the coverage provided by this endorsement:

1. The following paragraph is added to Paragraph 4.a. of the Other Insurance Condition of **Section IV – Commercial General Liability Conditions**:

This insurance is primary insurance as respects our coverage to the additional insured person or organization, where the written contract or written agreement requires that this insurance be primary and non-contributory. In that event, we will not seek contribution from any other insurance policy available to the additional insured on which the additional insured person or organization is a Named Insured.

2. The following paragraph is added to Paragraph 4.b. of the Other Insurance Condition of **Section IV – Commercial General Liability Conditions**:

This insurance is excess over:

Any of the other insurance, whether primary, excess, contingent or on any other basis, available to an additional insured, in which the additional insured on our policy is also covered as an additional insured by attachment of an endorsement to another policy providing coverage for the same "occurrence", claim or "suit". This provision does not apply to any policy in which the additional insured is a Named Insured on such other policy and where our policy is required by written contract or written agreement to provide coverage to the additional insured on a primary and non-contributory basis.

G. This endorsement does not apply to an additional insured which has been added to this policy by an endorsement showing the additional insured in a Schedule of additional insureds, and which endorsement applies specifically to that identified additional insured.

Any provisions in this Coverage Part not changed by the terms and conditions of this endorsement continue to apply as written.

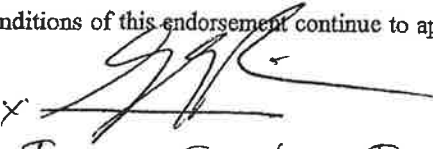
x 
Turner Surety & Insurance Brokerage

WAIVER OF TRANSFER OF RIGHTS OF RECOVERY AGAINST OTHERS TO US

THIS ENDORSEMENT CHANGES THE POLICY. PLEASE READ IT CAREFULLY.

POLICY NO.	EFF. DATE OF POL.	EXP. DATE OF POL.	EFF. DATE OF END.	AGENCY NO.	ADD'L. PREM.	RETURN PREM.
BAP593970802	06/01/2010	06/01/2011	06/01/2010			

Named Insured Flatiron Electric Group, Inc. F/K/A Terno, Inc.

Address (including ZIP Code) 15701 Heron Avenue, La Mirada, CA 90638

This endorsement modifies insurance provided by the following:
Business Auto Coverage Part
Truckers Coverage Part
Garage Coverage Part

SCHEDULE

Name of Person or Organization:

ALL PERSONS AND/OR ORGANIZATIONS THAT ARE REQUIRED BY WRITTEN CONTRACT OR AGREEMENT WITH THE INSURED, EXECUTED PRIOR TO THE ACCIDENT OR LOSS, THAT WAIVER OF SUBROGATION BE PROVIDED UNDER THIS POLICY.

We waive any right of recovery we may have against the designated person or organization shown in the schedule because of payments we make for injury or damage caused by an "accident" or "loss" resulting from the ownership, maintenance, or use of a covered "auto" for which a Waiver of Subrogation is required in conjunction with work performed by you for the designated person or organization. The waiver applies only to the designated person or organization shown in the schedule.

Countersigned

Anthony W. Zino
Authorized Representative

WORKERS' COMPENSATION AND EMPLOYERS' LIABILITY INSURANCE POLICY

WC 04 03 06 (Ed. 4-84)

**WAIVER OF OUR RIGHT TO RECOVER FROM OTHERS ENDORSEMENT—
CALIFORNIA**

This endorsement changes the policy to which it is attached effective on the inception date of the policy unless a different date is indicated below.

(The following "attaching clause" need be completed only when this endorsement is issued subsequent to preparation of the policy.)

This endorsement, effective on 06/01/2010

(DATE)

at 12:01 A.M. standard time, forms a part of

Policy No. WC913889904

Endorsement No.

of the

(NAME OF INSURANCE COMPANY)

issued to Flatiron Electric Group, Inc. F/K/A Terno, Inc.

Premium (if any) \$

Anthony W. Zino
Authorized Representative

We have the right to recover our payments from anyone liable for an injury covered by this policy. We will not enforce our right against the person or organization named in the Schedule. (This agreement applies only to the extent that you perform work under a written contract that requires you to obtain this agreement from us.)

You must maintain payroll records accurately segregating the remuneration of your employees while engaged in the work described in the Schedule.

The additional premium for this endorsement shall be _____ % of the California workers' compensation premium otherwise due on such remuneration.

Schedule

Person or Organization

Job Description

ALL PERSONS AND/OR ORGANIZATIONS THAT ARE REQUIRED BY WRITTEN CONTRACT OR AGREEMENT WITH THE INSURED, EXECUTED PRIOR TO THE ACCIDENT OR LOSS, THAT WAIVER OF SUBROGATION BE PROVIDED UNDER THIS POLICY FOR WORK PERFORMED BY YOU FOR THAT PERSON AND/OR ORGANIZATION

Company Profile

ZURICH AMERICAN INSURANCE COMPANY

1400 AMERICAN LANE
 SCHAUMBURG, IL 60196-1056
 800-382-2150

Agent for Service of Process

KAREN HARRIS, C/O CORPORATION SERVICE COMPANY 2730 GATEWAY OAKS DRIVE, SUITE 100
 SACRAMENTO, CA 95833

Unable to Locate the Agent for Service of Process?

Reference Information

NAIC #:	16535
NAIC Group #:	<u>0212</u>
California Company ID #:	4581-5
Date authorized in California:	January 01, 1999
License Status:	UNLIMITED-NORMAL
Company Type:	Property & Casualty
State of Domicile:	NEW YORK

Lines of Insurance Authorized to Transact

The company is authorized to transact business within these lines of insurance. For an explanation of any of these terms, please refer to the glossary.

AIRCRAFT
 AUTOMOBILE
 BOILER AND MACHINERY
 BURGLARY
 COMMON CARRIER LIABILITY
 CREDIT
 DISABILITY
 FIRE
 LIABILITY
 MARINE
 MISCELLANEOUS
 PLATE GLASS
 SPRINKLER
 SURETY
 TEAM AND VEHICLE
 WORKERS' COMPENSATION
