

**Section 5-2
Federal Prevailing Wage Decision**

General Decision Number: CA100036 01/21/2011 CA36

Date: January 21, 2011

Superseded General Decision Number: CA20080036

State: California

Construction Types: Building, Heavy (Heavy and Dredging) and Highway

County: Riverside County in California.

BUILDING CONSTRUCTION PROJECTS; DREDGING PROJECTS (does not include hopper dredge work); HEAVY CONSTRUCTION PROJECTS (does not include water well drilling); HIGHWAY CONSTRUCTION PROJECTS

Modification Number	Publication Date
0	03/12/2010
1	03/26/2010
2	04/02/2010
3	04/16/2010
4	06/25/2010
5	07/02/2010
6	07/23/2010
7	08/06/2010
8	08/13/2010
9	08/27/2010
10	09/03/2010
11	09/10/2010
12	09/24/2010
13	10/08/2010
14	12/03/2010
15	01/21/2011

ASBE0005-002 06/28/2010 *

	Rates	Fringes
Asbestos Workers/Insulator (Includes the application of all insulating materials, protective coverings, coatings, and finishes to all types of mechanical systems).....	\$ 32.79	16.31
Fire Stop Technician (Application of Firestopping Materials for wall openings and penetrations in walls, floors, ceilings and curtain walls).....	\$ 24.21	13.76

ASBE0005-004 06/28/2010

	Rates	Fringes
Asbestos Removal worker/hazardous material handler (Includes preparation, wetting, stripping, removal, scrapping, vacuuming, bagging		

and disposing of all insulation materials from mechanical systems, whether they contain asbestos or not)....\$ 18.70 8.65

BOIL0092-003 10/01/2009

	Rates	Fringes
BOILERMAKER.....	\$ 40.22	22.26

BRCA0004-011 05/01/2010

	Rates	Fringes
BRICKLAYER; MARBLE SETTER.....	\$ 35.25	10.62

BRCA0018-004 06/01/2008

	Rates	Fringes
MARBLE FINISHER.....	\$ 25.52	9.08
TILE FINISHER.....	\$ 21.07	7.88
TILE LAYER.....	\$ 32.05	11.99

BRCA0018-010 09/01/2009

	Rates	Fringes
TERRAZZO FINISHER.....	\$ 26.59	9.62
TERRAZZO WORKER/SETTER.....	\$ 33.63	10.46

CARP0409-001 07/01/2010

	Rates	Fringes
CARPENTER		
(1) Carpenter, Cabinet Installer, Insulation Installer, Hardwood Floor Worker and acoustical installer.....	\$37.35	11.08
(2) Millwright.....	\$37.85	11.08
(3) Piledriver/Derrick Bargeman, Bridge or Dock Carpenter, Heavy Framer, Rock Bargeman or Scowman, Rockslinger, Shingler (Commercial).....	\$37.48	11.08
(4) Pneumatic Nailer, Power Stapler.....	\$37.60	11.08
(5) Sawfiler.....	\$37.44	11.08
(6) Scaffold Builder.....	\$28.55	11.08
(7) Table Power Saw Operator.....	\$37.45	11.08

FOOTNOTE: Work of forming in the construction of open cut sewers or storm drains, on operations in which horizontal lagging is used in conjunction with steel H-Beams driven or placed in pre- drilled holes, for that portion of a lagged trench against which concrete is poured, namely, as a substitute for back forms (which work is performed by piledrivers): \$0.13 per hour additional. Certified Welder - \$1.00 per hour premium.

CARP0409-002 07/01/2008

	Rates	Fringes
Diver		
(1) Wet.....	\$ 663.68	9.82
(2) Standby.....	\$ 331.84	9.82
(3) Tender.....	\$ 323.84	9.82
(4) Assistant Tender.....	\$ 299.84	9.82

Amounts in "Rates" column are per day

CARP0409-005 07/01/2010

	Rates	Fringes
Drywall		
DRYWALL INSTALLER/LATHER.....	\$ 37.35	11.08
STOCKER/SCRAPPER.....	\$ 10.00	6.67

CARP0409-008 07/01/2008

	Rates	Fringes
Modular Furniture Installer.....	\$ 19.00	7.41

* ELEC0011-002 11/29/2010
COMMUNICATIONS AND SYSTEMS WORK

	Rates	Fringes
Communications System		
Installer.....	\$ 27.25	10.85
Technician.....	\$ 29.05	10.90

SCOPE OF WORK:

Installation, testing, service and maintenance of systems utilizing the transmission and/or transference of voice, sound, vision and digital for commercial, educational, security and entertainment purposes for the following: TV monitoring and surveillance, background-foreground music, intercom and telephone interconnect, inventory control systems, microwave transmission, multi-media, multiplex, nurse call systems, radio page, school intercom and sound, burglar alarms, fire alarm (see last paragraph below) and low voltage master clock systems in commercial buildings. Communication Systems that transmit or receive information and/or control systems that are intrinsic to the above listed systems; inclusion or exclusion of terminations and testings of conductors determined by their function; excluding all other data systems or multiple systems which include control function or power supply; excluding installation of raceway systems, conduit systems, line voltage work, and energy management systems. Does not cover work performed at China Lake Naval Ordnance Test Station. Fire alarm work shall be performed at the current inside wireman total cost package.

ELEC0440-001 06/01/2010

	Rates	Fringes
ELECTRICIAN		
INSIDE ELECTRICIAN.....	\$ 35.70	3%+16.54
INTELLIGENT TRANSPORTATION SYSTEMS		
Electrician.....	\$ 35.00	3%+15.14
Technician.....	\$ 26.25	3%+15.14

ZONE PAY: Zone A: Free travel zone for all contractors performing work in Zone A.

Zone B: Any work performed in Zone (B) shall add \$8.00 per hour to the current wage scale. Zone (B) shall be the area from the eastern perimeter of Zone (A) to a line which runs north and south beginning at Little Morongo Canyon (San Bernardino/Riverside County Line), Southeast along the Coachella Tunnels, Colorado River Aqueduct and Mecca Tunnels to Pinkham Wash then South to Box Canyon Road, then southwest along Box Canyon Road to Highway 195 west onto 195 south to Highway 86 to Riverside/Imperial County Line.

ELEC1245-001 06/01/2010

	Rates	Fringes
LINE CONSTRUCTION		
(1) Lineman; Cable splicer..	\$ 46.14	13.41

(2) Equipment specialist
 (operates crawler
 tractors, commercial motor
 vehicles, backhoes,
 trenchers, cranes (50 tons
 and below), overhead &
 underground distribution
 line equipment)..... \$ 36.85 12.36
 (3) Groundman..... \$ 28.19 12.10
 (4) Powderman..... \$ 41.20 12.53

HOLIDAYS: New Year's Day, M.L. King Day, Memorial Day,
 Independence Day, Labor Day, Veterans Day, Thanksgiving Day
 and day after Thanksgiving, Christmas Day

ELEV0018-001 01/01/2010

	Rates	Fringes
ELEVATOR MECHANIC.....	\$ 45.33	20.035

FOOTNOTE:

PAID VACATION: Employer contributes 8% of regular hourly
 rate as vacation pay credit for employees with more than 5
 years of service, and 6% for 6 months to 5 years of service.
 PAID HOLIDAYS: New Years Day, Memorial Day, Independence Day,
 Labor Day, Veterans Day, Thanksgiving Day, Friday after
 Thanksgiving, and Christmas Day.

* ENGI0012-003 01/01/2011

	Rates	Fringes
OPERATOR: Power Equipment (All Other Work)		
GROUP 1.....	\$ 36.83	18.72
GROUP 2.....	\$ 37.61	18.72
GROUP 3.....	\$ 37.90	18.72
GROUP 4.....	\$ 39.39	18.72
GROUP 5.....	\$ 40.49	18.72
GROUP 6.....	\$ 39.61	18.72
GROUP 7.....	\$ 40.71	18.72
GROUP 8.....	\$ 39.72	18.72
GROUP 9.....	\$ 40.82	18.72
GROUP 10.....	\$ 39.84	18.72
GROUP 11.....	\$ 40.94	18.72
GROUP 12.....	\$ 40.01	18.72
GROUP 13.....	\$ 40.11	18.72
GROUP 14.....	\$ 40.14	18.72
GROUP 15.....	\$ 40.22	18.72
GROUP 16.....	\$ 40.34	18.72
GROUP 17.....	\$ 40.51	18.72
GROUP 18.....	\$ 40.61	18.72
GROUP 19.....	\$ 40.72	18.72
GROUP 20.....	\$ 40.84	18.72
GROUP 21.....	\$ 41.01	18.72
GROUP 22.....	\$ 41.11	18.72
GROUP 23.....	\$ 41.22	18.72
GROUP 24.....	\$ 41.34	18.72
GROUP 25.....	\$ 41.51	18.72
OPERATOR: Power Equipment (Cranes, Piledriving & Hoisting)		
GROUP 1.....	\$ 38.18	18.72
GROUP 2.....	\$ 38.96	18.72
GROUP 3.....	\$ 39.25	18.72
GROUP 4.....	\$ 39.39	18.72
GROUP 5.....	\$ 39.61	18.72
GROUP 6.....	\$ 39.72	18.72

GROUP 7.....	\$ 39.84	18.72
GROUP 8.....	\$ 40.01	18.72
GROUP 9.....	\$ 40.18	18.72
GROUP 10.....	\$ 41.18	18.72
GROUP 11.....	\$ 42.18	18.72
GROUP 12.....	\$ 43.18	18.72
GROUP 13.....	\$ 44.18	18.72
OPERATOR: Power Equipment (Tunnel Work)		
GROUP 1.....	\$ 38.68	18.72
GROUP 2.....	\$ 39.46	18.72
GROUP 3.....	\$ 39.75	18.72
GROUP 4.....	\$ 39.89	18.72
GROUP 5.....	\$ 40.11	18.72
GROUP 6.....	\$ 40.22	18.72
GROUP 7.....	\$ 40.34	18.72

PREMIUM PAY:

\$3.75 per hour shall be paid on all Power Equipment Operator work on the following Military Bases: China Lake Naval Reserve, Vandenberg AFB, Point Arguello, Seely Naval Base, Fort Irwin, Nebo Annex Marine Base, Marine Corp Logistics Base Yermo, Edwards AFB, 29 Palms Marine Base and Camp Pendleton

Workers required to suit up and work in a hazardous material environment: \$2.00 per hour additional. Combination mixer and compressor operator on gunite work shall be classified as a concrete mobile mixer operator.

SEE ZONE DEFINITIONS AFTER CLASSIFICATIONS

POWER EQUIPMENT OPERATORS CLASSIFICATIONS

GROUP 1: Bargeman; Brakeman; Compressor operator; Ditch Witch, with seat or similar type equipment; Elevator operator-inside; Engineer Oiler; Forklift operator (includes loed, lull or similar types under 5 tons; Generator operator; Generator, pump or compressor plant operator; Pump operator; Signalman; Switchman

GROUP 2: Asphalt-rubber plant operator (nurse tank operator); Concrete mixer operator-skip type; Conveyor operator; Fireman; Forklift operator (includes loed, lull or similar types over 5 tons; Hydrostatic pump operator; oiler crusher (asphalt or concrete plant); Petromat laydown machine; PJU side dum jack; Screening and conveyor machine operator (or similar types); Skiploader (wheel type up to 3/4 yd. without attachment); Tar pot fireman; Temporary heating plant operator; Trenching machine oiler

GROUP 3: Asphalt-rubber blend operator; Bobcat or similar type (Skid steer); Equipment greaser (rack); Ford Ferguson (with dragtype attachments); Helicopter radioman (ground); Stationary pipe wrapping and cleaning machine operator

GROUP 4: Asphalt plant fireman; Backhoe operator (mini-max or similar type); Boring machine operator; Boxman or mixerman (asphalt or concrete); Chip spreading machine operator; Concrete cleaning decontamination machine operator; Concrete Pump Operator (small portable); Drilling machine operator, small auger types (Texoma super economatic or similar types - Hughes 100 or 200 or similar types -

drilling depth of 30' maximum); Equipment greaser (grease truck); Guard rail post driver operator; Highline cableway signalman; Horizontal Directional Drilling Machine; Hydra-hammer-aero stomper; Micro Tunneling (above ground tunnel); Power concrete curing machine operator; Power concrete saw operator; Power-driven jumbo form setter operator; Power sweeper operator; Rock Wheel Saw/Trencher; Roller operator (compacting); Screed operator (asphalt or concrete); Trenching machine operator (up to 6 ft.); Vacuum or much truck

GROUP 5: Equipment Greaser (Grease Truck/Multi Shift).

GROUP 6: Articulating material hauler; Asphalt plant engineer; Batch plant operator; Bit sharpener; Concrete joint machine operator (canal and similar type); Concrete planer operator; Dandy digger; Deck engine operator; Derrickman (oilfield type); Drilling machine operator, bucket or auger types (Calweld 100 bucket or similar types - Watson 1000 auger or similar types - Texoma 330, 500 or 600 auger or similar types - drilling depth of 45' maximum); Drilling machine operator; Hydrographic seeder machine operator (straw, pulp or seed), Jackson track maintainer, or similar type; Kalamazoo Switch tamper, or similar type; Machine tool operator; Maginnis internal full slab vibrator, Mechanical berm, curb or gutter (concrete or asphalt); Mechanical finisher operator (concrete, Clary-Johnson-Bidwell or similar); Micro tunnel system (below ground); Pavement breaker operator (truck mounted); Road oil mixing machine operator; Roller operator (asphalt or finish), rubber-tired earth moving equipment (single engine, up to and including 25 yds. struck); Self-propelled tar pipelining machine operator; Skiploader operator (crawler and wheel type, over 3/4 yd. and up to and including 1-1/2 yds.); Slip form pump operator (power driven hydraulic lifting device for concrete forms); Tractor operator-bulldozer, tamper-scraper (single engine, up to 100 h.p. flywheel and similar types, up to and including D-5 and similar types); Tugger hoist operator (1 drum); Ultra high pressure waterjet cutting tool system operator; Vacuum blasting machine operator

GROUP 7: Welder - General

GROUP 8: Asphalt or concrete spreading operator (tamping or finishing); Asphalt paving machine operator (Barber Greene or similar type); Asphalt-rubber distribution operator; Backhoe operator (up to and including 3/4 yd.), small ford, Case or similar; Cast-in-place pipe laying machine operator; Combination mixer and compressor operator (gunite work); Compactor operator (self-propelled); Concrete mixer operator (paving); Crushing plant operator; Drill Doctor; Drilling machine operator, Bucket or auger types (Calweld 150 bucket or similar types - Watson 1500, 2000 2500 auger or similar types - Texoma 700, 800 auger or similar types - drilling depth of 60' maximum); Elevating grader operator; Grade checker; Gradall operator; Grouting machine operator; Heavy-duty repairman; Heavy equipment robotics operator; Kalamazoo balliste regulator or similar type; Kolman belt loader and similar type; Le Tourneau blob compactor or similar type; Loader operator (Athey, Euclid, Sierra and similar types); Mobark Chipper or similar; Ozzie padder or similar types; P.C. slot saw; Pneumatic concrete placing

machine operator (Hackley-Presswell or similar type); Pumpcrete gun operator; Rock Drill or similar types; Rotary drill operator (excluding caisson type); Rubber-tired earth-moving equipment operator (single engine, caterpillar, Euclid, Athey Wagon and similar types with any and all attachments over 25 yds. up to and including 50 cu. yds. struck); Rubber-tired earth-moving equipment operator (multiple engine up to and including 25 yds. struck); Rubber-tired scraper operator (self-loading paddle wheel type-John Deere, 1040 and similar single unit); Selfpropelled curb and gutter machine operator; Shuttle buggy; Skiploader operator (crawler and wheel type over 1-1/2 yds. up to and including 6-1/2 yds.); Soil remediation plant operator; Surface heaters and planer operator; Tractor compressor drill combination operator; Tractor operator (any type larger than D-5 - 100 flywheel h.p. and over, or similar-bulldozer, tamper, scraper and push tractor single engine); Tractor operator (boom attachments), Traveling pipe wrapping, cleaning and bending machine operator; Trenching machine operator (over 6 ft. depth capacity, manufacturer's rating); trenching Machine with Road Miner attachment (over 6 ft depth capacity): Ultra high pressure waterjet cutting tool system mechanic; Water pull (compaction) operator

GROUP 9: Heavy Duty Repairman

GROUP 10: Drilling machine operator, Bucket or auger types (Calweld 200 B bucket or similar types-Watson 3000 or 5000 auger or similar types-Texoma 900 auger or similar types-drilling depth of 105' maximum); Dual drum mixer, dynamic compactor LDC350 (or similar types); Monorail locomotive operator (diesel, gas or electric); Motor patrol-blade operator (single engine); Multiple engine tractor operator (Euclid and similar type-except Quad 9 cat.); Rubber-tired earth-moving equipment operator (single engine, over 50 yds. struck); Pneumatic pipe ramming tool and similar types; Prestressed wrapping machine operator; Rubber-tired earth-moving equipment operator (single engine, over 50 yds. struck); Rubber tired earth moving equipment operator (multiple engine, Euclid, caterpillar and similar over 25 yds. and up to 50 yds. struck), Tower crane repairman; Tractor loader operator (crawler and wheel type over 6-1/2 yds.); Woods mixer operator (and similar Pugmill equipment)

GROUP 11: Heavy Duty Repairman - Welder Combination, Welder - Certified.

GROUP 12: Auto grader operator; Automatic slip form operator; Drilling machine operator, bucket or auger types (Calweld, auger 200 CA or similar types - Watson, auger 6000 or similar types - Hughes Super Duty, auger 200 or similar types - drilling depth of 175' maximum); Hoe ram or similar with compressor; Mass excavator operator less tha 750 cu. yards; Mechanical finishing machine operator; Mobile form traveler operator; Motor patrol operator (multi-engine); Pipe mobile machine operator; Rubber-tired earth-moving equipment operator (multiple engine, Euclid, Caterpillar and similar type, over 50 cu. yds. struck); Rubber-tired self-loading scraper operator (paddle-wheel-auger type self-loading - two (2) or more units)

GROUP 13: Rubber-tired earth-moving equipment operator operating equipment with push-pull system (single engine, up to and including 25 yds. struck)

GROUP 14: Canal liner operator; Canal trimmer operator; Remote-control earth-moving equipment operator (operating a second piece of equipment: \$1.00 per hour additional); Wheel excavator operator (over 750 cu. yds.)

GROUP 15: Rubber-tired earth-moving equipment operator, operating equipment with push-pull system (single engine, Caterpillar, Euclid, Athey Wagon and similar types with any and all attachments over 25 yds. and up to and including 50 yds. struck); Rubber-tired earth-moving equipment operator, operating equipment with push-pull system (multiple engine-up to and including 25 yds. struck)

GROUP 16: Rubber-tired earth-moving equipment operator, operating equipment with push-pull system (single engine, over 50 yds. struck); Rubber-tired earth-moving equipment operator, operating equipment with push-pull system (multiple engine, Euclid, Caterpillar and similar, over 25 yds. and up to 50 yds. struck)

GROUP 17: Rubber-tired earth-moving equipment operator, operating equipment with push-pull system (multiple engine, Euclid, Caterpillar and similar, over 50 cu. yds. struck); Tandem tractor operator (operating crawler type tractors in tandem - Quad 9 and similar type)

GROUP 18: Rubber-tired earth-moving equipment operator, operating in tandem (scrapers, belly dumps and similar types in any combination, excluding compaction units - single engine, up to and including 25 yds. struck)

GROUP 19: Rotex concrete belt operator (or similar types); Rubber-tired earth-moving equipment operator, operating in tandem (scrapers, belly dumps and similar types in any combination, excluding compaction units - single engine, Caterpillar, Euclid, Athey Wagon and similar types with any and all attachments over 25 yds. and up to and including 50 cu. yds. struck); Rubber-tired earth-moving equipment operator, operating in tandem (scrapers, belly dumps and similar types in any combination, excluding compaction units - multiple engine, up to and including 25 yds. struck)

GROUP 20: Rubber-tired earth-moving equipment operator, operating in tandem (scrapers, belly dumps and similar types in any combination, excluding compaction units - single engine, over 50 yds. struck); Rubber-tired earth-moving equipment operator, operating in tandem (scrapers, belly dumps, and similar types in any combination, excluding compaction units - multiple engine, Euclid, Caterpillar and similar, over 25 yds. and up to 50 yds. struck)

GROUP 21: Rubber-tired earth-moving equipment operator, operating in tandem (scrapers, belly dumps and similar types in any combination, excluding compaction units - multiple engine, Euclid, Caterpillar and similar type, over 50 cu. yds. struck)

GROUP 22: Rubber-tired earth-moving equipment operator,

operating equipment with the tandem push-pull system
(single engine, up to and including 25 yds. struck)

GROUP 23: Rubber-tired earth-moving equipment operator, operating equipment with the tandem push-pull system (single engine, Caterpillar, Euclid, Athey Wagon and similar types with any and all attachments over 25 yds. and up to and including 50 yds. struck); Rubber-tired earth-moving equipment operator, operating with the tandem push-pull system (multiple engine, up to and including 25 yds. struck)

GROUP 24: Rubber-tired earth-moving equipment operator, operating equipment with the tandem push-pull system (single engine, over 50 yds. struck); Rubber-tired earth-moving equipment operator, operating equipment with the tandem push-pull system (multiple engine, Euclid, Caterpillar and similar, over 25 yds. and up to 50 yds. struck)

GROUP 25: Concrete pump operator-truck mounted; Rubber-tired earth-moving equipment operator, operating equipment with the tandem push-pull system (multiple engine, Euclid, Caterpillar and similar type, over 50 cu. yds. struck)

CRANES, PILEDIVING AND HOISTING EQUIPMENT CLASSIFICATIONS

GROUP 1: Engineer oiler; Fork lift operator (includes loed, lull or similar types)

GROUP 2: Truck crane oiler

GROUP 3: A-frame or winch truck operator; Ross carrier operator (jobsite)

GROUP 4: Bridge-type unloader and turntable operator; Helicopter hoist operator

GROUP 5: Hydraulic boom truck; Stinger crane (Austin-Western or similar type); Tugger hoist operator (1 drum)

GROUP 6: Bridge crane operator; Cretor crane operator; Hoist operator (Chicago boom and similar type); Lift mobile operator; Lift slab machine operator (Vagtborg and similar types); Material hoist and/or manlift operator; Polar gantry crane operator; Self Climbing scaffold (or similar type); Shovel, backhoe, dragline, clamshell operator (over 3/4 yd. and up to 5 cu. yds. mrc); Tugger hoist operator

GROUP 7: Pedestal crane operator; Shovel, backhoe, dragline, clamshell operator (over 5 cu. yds. mrc); Tower crane repair; Tugger hoist operator (3 drum)

GROUP 8: Crane operator (up to and including 25 ton capacity); Crawler transporter operator; Derrick barge operator (up to and including 25 ton capacity); Hoist operator, stiff legs, Guy derrick or similar type (up to and including 25 ton capacity); Shovel, backhoe, dragline, clamshell operator (over 7 cu. yds., M.R.C.)

GROUP 9: Crane operator (over 25 tons and up to and including 50 tons mrc); Derrick barge operator (over 25 tons up to and including 50 tons mrc); Highline cableway operator;

Hoist operator, stiff legs, Guy derrick or similar type (over 25 tons up to and including 50 tons mrc); K-crane operator; Polar crane operator; Self erecting tower crane operator maximum lifting capacity ten tons

GROUP 10: Crane operator (over 50 tons and up to and including 100 tons mrc); Derrick barge operator (over 50 tons up to and including 100 tons mrc); Hoist operator, stiff legs, Guy derrick or similar type (over 50 tons up to and including 100 tons mrc), Mobile tower crane operator (over 50 tons, up to and including 100 tons M.R.C.); Tower crane operator and tower gantry

GROUP 11: Crane operator (over 100 tons and up to and including 200 tons mrc); Derrick barge operator (over 100 tons up to and including 200 tons mrc); Hoist operator, stiff legs, Guy derrick or similar type (over 100 tons up to and including 200 tons mrc); Mobile tower crane operator (over 100 tons up to and including 200 tons mrc)

GROUP 12: Crane operator (over 200 tons up to and including 300 tons mrc); Derrick barge operator (over 200 tons up to and including 300 tons mrc); Hoist operator, stiff legs, Guy derrick or similar type (over 200 tons, up to and including 300 tons mrc); Mobile tower crane operator (over 200 tons, up to and including 300 tons mrc)

GROUP 13: Crane operator (over 300 tons); Derrick barge operator (over 300 tons); Helicopter pilot; Hoist operator, stiff legs, Guy derrick or similar type (over 300 tons); Mobile tower crane operator (over 300 tons)

TUNNEL CLASSIFICATIONS

GROUP 1: Skiploader (wheel type up to 3/4 yd. without attachment)

GROUP 2: Power-driven jumbo form setter operator

GROUP 3: Dinkey locomotive or motorperson (up to and including 10 tons)

GROUP 4: Bit sharpener; Equipment greaser (grease truck); Slip form pump operator (power-driven hydraulic lifting device for concrete forms); Tugger hoist operator (1 drum); Tunnel locomotive operator (over 10 and up to and including 30 tons)

GROUP 5: Backhoe operator (up to and including 3/4 yd.); Small Ford, Case or similar; Drill doctor; Grouting machine operator; Heading shield operator; Heavy-duty repairperson; Loader operator (Athey, Euclid, Sierra and similar types); Mucking machine operator (1/4 yd., rubber-tired, rail or track type); Pneumatic concrete placing machine operator (Hackley-Presswell or similar type); Pneumatic heading shield (tunnel); Pumpcrete gun operator; Tractor compressor drill combination operator; Tugger hoist operator (2 drum); Tunnel locomotive operator (over 30 tons)

GROUP 6: Heavy Duty Repairman

GROUP 7: Tunnel mole boring machine operator

ENGINEERS ZONES

\$1.00 additional per hour for all of IMPERIAL County and the portions of KERN, RIVERSIDE & SAN BERNARDINO Counties as defined below:

That area within the following Boundary: Begin in San Bernardino County, approximately 3 miles NE of the intersection of I-15 and the California State line at that point which is the NW corner of Section 1, T17N,m R14E, San Bernardino Meridian. Continue W in a straight line to that point which is the SW corner of the northwest quarter of Section 6, T27S, R42E, Mt. Diablo Meridian. Continue North to the intersection with the Inyo County Boundary at that point which is the NE corner of the western half of the northern quarter of Section 6, T25S, R42E, MDM. Continue W along the Inyo and San Bernardino County boundary until the intersection with Kern County, as that point which is the SE corner of Section 34, T24S, R40E, MDM. Continue W along the Inyo and Kern County boundary until the intersection with Tulare County, at that point which is the SW corner of the SE quarter of Section 32, T24S, R37E, MDM. Continue W along the Kern and Tulare County boundary, until that point which is the NW corner of T25S, R32E, MDM. Continue S following R32E lines to the NW corner of T31S, R32E, MDM. Continue W to the NW corner of T31S, R31E, MDM. Continue S to the SW corner of T32S, R31E, MDM. Continue W to SW corner of SE quarter of Section 34, T32S, R30E, MDM. Continue S to SW corner of T11N, R17W, SBM. Continue E along south boundary of T11N, SBM to SW corner of T11N, R7W, SBM. Continue S to SW corner of T9N, R7W, SBM. Continue E along south boundary of T9N, SBM to SW corner of T9N, R1E, SBM. Continue S along west boundary of R1E, SMB to Riverside County line at the SW corner of T1S, R1E, SBM. Continue E along south boundary of T1s, SBM (Riverside County Line) to SW corner of T1S, R10E, SBM. Continue S along west boundary of R10E, SBM to Imperial County line at the SW corner of T8S, R10E, SBM. Continue W along Imperial and Riverside county line to NW corner of T9S, R9E, SBM. Continue S along the boundary between Imperial and San Diego Counties, along the west edge of R9E, SBM to the south boundary of Imperial County/California state line. Follow the California state line west to Arizona state line, then north to Nevada state line, then continuing NW back to start at the point which is the NW corner of Section 1, T17N, R14E, SBM

\$1.00 additional per hour for portions of SAN LUIS OBISPO, KERN, SANTA BARBARA & VENTURA as defined below:

That area within the following Boundary: Begin approximately 5 miles north of the community of Cholame, on the Monterey County and San Luis Obispo County boundary at the NW corner of T25S, R16E, Mt. Diablo Meridian. Continue south along the west side of R16E to the SW corner of T30S, R16E, MDM. Continue E to SW corner of T30S, R17E, MDM. Continue S to SW corner of T31S, R17E, MDM. Continue E to SW corner of T31S, R18E, MDM. Continue S along West side of R18E, MDM as it crosses into San Bernardino Meridian numbering area and becomes R30W. Follow the west side of R30W, SBM to the SW corner of T9N, R30W, SBM. Continue E along the south edge of T9N, SBM to the Santa Barbara County and Ventura County boundary at that point which is the SW corner of Section 34. T9N, R24W, SBM, continue S along the Ventura County line to that point which is the SW corner of the SE quarter of Section 32, T7N, R24W, SBM. Continue E along the south edge of T7N, SBM to the SE corner to T7N, R21W,

SBM. Continue N along East side of R21W, SBM to Ventura County and Kern County boundary at the NE corner of T8N, R21W. Continue W along the Ventura County and Kern County boundary to the SE corner of T9N, R21W. Continue North along the East edge of R21W, SBM to the NE corner of T12N, R21W, SBM. Continue West along the north edge of T12N, SBM to the SE corner of T32S, R21E, MDM. [T12N SBM is a think strip between T11N SBM and T32S MDM]. Continue North along the East side of R21E, MDM to the Kings County and Kern County border at the NE corner of T25S, R21E, MDM, continue West along the Kings County and Kern County Boundary until the intersection of San Luis Obispo County. Continue west along the Kings County and San Luis Obispo County boundary until the intersection with Monterey County. Continue West along the Monterey County and San Luis Obispo County boundary to the beginning point at the NW corner of T25S, R16E, MDM.

\$2.00 additional per hour for INYO and MONO Counties and the Northern portion of SAN BERNARDINO County as defined below: That area within the following Boundary: Begin at the intersection of the northern boundary of Mono County and the California state line at the point which is the center of

Section 17, T10N, R22E, Mt. Diablo Meridian. Continue S then SE along the entire western boundary of Mono County, until it reaches Inyo County at the point which is the NE corner of the Western half of the NW quarter of Section 2, T8S, R29E, MDM. Continue SSE along the entire western boundary of Inyo County, until the intersection with Kern County at the point which is the SW corner of the SE 1/2 of Section 32, T24S, R37E, MDM. Continue E along the Inyo and Kern County boundary until the intersection with San Bernardino County at that point which is the SE corner of section 34, T24S, R40E, MDM. Continue E along the Inyo and San Bernardino County boundary until the point which is the NE corner of the Western half of the NW quarter of Section 6, T25S, R42E, MDM. Continue S to that point which is the SW corner of the NW quarter of Section 6, T27S, R42E, MDM. Continue E in a straight line to the California and Nevada state border at the point which is the NW corner of Section 1, T17N, R14E, San Bernardino Meridian. Then continue NW along the state line to the starting point, which is the center of

Section 18, T10N, R22E, MDM.

REMAINING AREA NOT DEFINED ABOVE RECIEVES BASE RATE

 ENGI0012-004 08/01/2009

Rates Fringes

OPERATOR: Power Equipment

(DREDGING)

(1) Leverman.....	\$ 44.83	17.22
(2) Dredge dozer.....	\$ 40.36	17.22
(3) Deckmate.....	\$ 40.25	17.22
(4) Winch operator (stern winch on dredge).....	\$ 39.70	17.22
(5) Fireman-Oiler, Deckhand, Bargeman, Leveehand.....	\$ 39.16	17.22
(6) Barge Mate.....	\$ 39.77	17.22

 IRON0002-004 07/01/2010

Rates Fringes

Ironworkers:

Fence Erector.....	\$ 26.58	15.26
--------------------	----------	-------

Ornamental, Reinforcing
and Structural.....\$ 33.00 23.73

PREMIUM PAY:

\$6.00 additional per hour at the following locations:

China Lake Naval Test Station, Chocolate Mountains Naval Reserve-Niland,

Edwards AFB, Fort Irwin Military Station, Fort Irwin Training Center-Goldstone, San Clemente Island, San Nicholas Island,

Susanville Federal Prison, 29 Palms - Marine Corps, U.S. Marine Base - Barstow, U.S. Naval Air Facility - Sealey, Vandenberg AFB

\$4.00 additional per hour at the following locations:

Army Defense Language Institute - Monterey, Fallon Air Base, Naval Post Graduate School - Monterey, Yermo Marine Corps

Logistics Center

\$2.00 additional per hour at the following locations:

Port Hueneme, Port Mugu, U.S. Coast Guard Station - Two Rock

LABO0300-001 09/01/2010

Rates Fringes

Brick Tender.....\$ 27.17 14.72

LABO0300-003 07/01/2010

Rates Fringes

LABORER (GUNITE)

GROUP 1.....\$ 30.04 17.37

GROUP 2.....\$ 29.09 17.37

GROUP 3.....\$ 25.55 17.37

LABORER (TUNNEL)

GROUP 1.....\$ 31.24 14.98

GROUP 2.....\$ 31.56 14.98

GROUP 3.....\$ 32.02 14.98

GROUP 4.....\$ 32.71 14.98

LABORER

GROUP 1.....\$ 26.33 14.75

GROUP 2.....\$ 26.88 14.75

GROUP 3.....\$ 27.43 14.75

GROUP 4.....\$ 28.98 14.75

GROUP 5.....\$ 29.33 14.75

FOOTNOTE: GUNITE PREMIUM PAY: Workers working from a Bosn'n's Chair or suspended from a rope or cable shall receive 40 cents per hour above the foregoing applicable classification rates. Workers doing gunitite and/or shotcrete work in a tunnel shall receive 35 cents per hour above the foregoing applicable classification rates, paid on a portal-to-portal basis. Any work performed on, in or above any smoke stack, silo, storage elevator or similar type of structure, when such structure is in excess of 75'-0" above base level and which work must be performed in whole or in part more than 75'-0" above base level, that work performed above the 75'-0" level shall be compensated for at 35 cents per hour above the applicable classification wage rate.

LABORER CLASSIFICATIONS

GROUP 1: Cleaning and handling of panel forms; Concrete screeding for rough strike-off; Concrete, water curing; Demolition laborer, the cleaning of brick if performed by a worker performing any other phase of demolition work, and the cleaning of lumber; Fire watcher, limber, brush loader, piler and debris handler; Flag person; Gas, oil and/or

water pipeline laborer; Laborer, asphalt-rubber material loader; Laborer, general or construction; Laborer, general clean-up; Laborer, landscaping; Laborer, jetting; Laborer, temporary water and air lines; Material hose operator (walls, slabs, floors and decks); Plugging, filling of shee bolt holes; Dry packing of concrete; Railroad maintenance, repair track person and road beds; Streetcar and railroad construction track laborers; Rigging and signaling; Scaler; Slip form raiser; Tar and mortar; Tool crib or tool house laborer; Traffic control by any method; Window cleaner; Wire mesh pulling - all concrete pouring operations

GROUP 2: Asphalt shoveler; Cement dumper (on 1 yd. or larger mixer and handling bulk cement); Cesspool digger and installer; Chucktender; Chute handler, pouring concrete, the handling of the chute from readymix trucks, such as walls, slabs, decks, floors, foundation, footings, curbs, gutters and sidewalks; Concrete curer, impervious membrane and form oiler; Cutting torch operator (demolition); Fine grader, highways and street paving, airport, runways and similar type heavy construction; Gas, oil and/or water pipeline wrapper - pot tender and form person; Guinea chaser; Headerboard person - asphalt; Laborer, packing rod steel and pans; Membrane vapor barrier installer; Power broom sweeper (small); Riprap stonepaver, placing stone or wet sacked concrete; Roto scraper and tiller; Sandblaster (pot tender); Septic tank digger and installer(lead); Tank scaler and cleaner; Tree climber, faller, chain saw operator, Pittsburgh chipper and similar type brush shredder; Underground laborer, including caisson bellower

GROUP 3: Buggymobile person; Concrete cutting torch; Concrete pile cutter; Driller, jackhammer, 2-1/2 ft. drill steel or longer; Dri-pak-it machine; Gas, oil and/or water pipeline wrapper, 6-in. pipe and over, by any method, inside and out; High scaler (including drilling of same); Hydro seeder and similar type; Impact wrench multi-plate; Kettle person, pot person and workers applying asphalt, lay-kold, creosote, lime caustic and similar type materials ("applying" means applying, dipping, brushing or handling of such materials for pipe wrapping and waterproofing); Operator of pneumatic, gas, electric tools, vibrating machine, pavement breaker, air blasting, come-alongs, and similar mechanical tools not separately classified herein; Pipelayer's backup person, coating, grouting, making of joints, sealing, caulking, diapering and including rubber gasket joints, pointing and any and all other services; Rock slinger; Rotary scarifier or multiple head concrete chipping scarifier; Steel headerboard and guideline setter; Tamper, Barko, Wacker and similar type; Trenching machine, hand-propelled

GROUP 4: Asphalt raker, lute person, ironer, asphalt dump person, and asphalt spreader boxes (all types); Concrete core cutter (walls, floors or ceilings), grinder or sander; Concrete saw person, cutting walls or flat work, scoring old or new concrete; Cribber, shorer, lagging, sheeting and trench bracing, hand-guided lagging hammer; Head rock slinger; Laborer, asphalt- rubber distributor boot person; Laser beam in connection with laborers' work; Oversize concrete vibrator operator, 70 lbs. and over; Pipelayer performing all services in the laying and installation of pipe from the point of receiving pipe in the ditch until

completion of operation, including any and all forms of tubular material, whether pipe, metallic or non-metallic, conduit and any other stationary type of tubular device used for the conveying of any substance or element, whether water, sewage, solid gas, air, or other product whatsoever and without regard to the nature of material from which the tubular material is fabricated; No-joint pipe and stripping of same; Prefabricated manhole installer; Sandblaster (nozzle person), water blasting, Porta Shot-Blast GROUP 5: Blaster powder, all work of loading holes, placing and blasting of all powder and explosives of whatever type, regardless of method used for such loading and placing; Driller: All power drills, excluding jackhammer, whether core, diamond, wagon, track, multiple unit, and any and all other types of mechanical drills without regard to the form of motive power; Toxic waste removal

TUNNEL LABORER CLASSIFICATIONS

GROUP 1: Batch plant laborer; Bull gang mucker, track person; Changehouse person; Concrete crew, including rodder and spreader; Dump person; Dump person (outside); Swamper (brake person and switch person on tunnel work); Tunnel materials handling person

GROUP 2: Chucktender, cabletender; Loading and unloading agitator cars; Nipper; Pot tender, using mastic or other materials (for example, but not by way of limitation, shotcrete, etc.); Vibrator person, jack hammer, pneumatic tools (except driller)

GROUP 3: Blaster, driller, powder person; Chemical grout jet person; Cherry picker person; Grout gun person; Grout mixer person; Grout pump person; Jackleg miner; Jumbo person; Kemper and other pneumatic concrete placer operator; Miner, tunnel (hand or machine); Nozzle person; Operating of troweling and/or grouting machines; Powder person (primer house); Primer person; Sandblaster; Shotcrete person; Steel form raiser and setter; Timber person, retimber person, wood or steel; Tunnel Concrete finisher

GROUP 4: Diamond driller; Sandblaster; Shaft and raise work

GUNITE LABORER CLASSIFICATIONS

GROUP 1: Rodmen, Nozzlemen

GROUP 2: Gunmen

GROUP 3: Reboundmen

LABO0300-005 08/05/2009

Rates Fringes

LABORER

PLASTER CLEAN-UP LABORER...\$ 26.65 14.70
PLASTER TENDER.....\$ 29.20 14.70

LABO0882-002 01/01/2010

Rates Fringes

Asbestos Removal Laborer.....\$ 26.15 14.25
SCOPE OF WORK: Includes site mobilization, initial site cleanup, site preparation, removal of asbestos-containing material and toxic waste, encapsulation, enclosure and

disposal of asbestos- containing materials and toxic waste by hand or with equipment or machinery; scaffolding, fabrication of temporary wooden barriers and assembly of decontamination stations.

LABO1184-001 07/01/2010

Rates Fringes

Laborers: (HORIZONTAL DIRECTIONAL DRILLING)

(1) Drilling Crew Laborer...\$ 27.05 11.65
(2) Vehicle Operator/Hauler.\$ 27.22 11.65
(3) Horizontal Directional Drill Operator.....\$ 29.07 11.65
(4) Electronic Tracking Locator.....\$ 31.07 11.65

Laborers: (STRIPING/SLURRY SEAL)

GROUP 1.....\$ 28.50 14.56
GROUP 2.....\$ 29.80 14.56
GROUP 3.....\$ 31.81 14.56
GROUP 4.....\$ 33.55 14.56

LABORERS - STRIPING CLASSIFICATIONS

GROUP 1: Protective coating, pavement sealing, including repair and filling of cracks by any method on any surface in parking lots, game courts and playgrounds; carstops; operation of all related machinery and equipment; equipment repair technician

GROUP 2: Traffic surface abrasive blaster; pot tender - removal of all traffic lines and markings by any method (sandblasting, waterblasting, grinding, etc.) and preparation of surface for coatings. Traffic control person: controlling and directing traffic through both conventional and moving lane closures; operation of all related machinery and equipment

GROUP 3: Traffic delineating device applicator: Layout and application of pavement markers, delineating signs, rumble and traffic bars, adhesives, guide markers, other traffic delineating devices including traffic control. This category includes all traffic related surface preparation (sandblasting, waterblasting, grinding) as part of the application process. Traffic protective delineating system installer: removes, relocates, installs, permanently affixed roadside and parking delineation barricades, fencing, cable anchor, guard rail, reference signs, monument markers; operation of all related machinery and equipment; power broom sweeper

GROUP 4: Striper: layout and application of traffic stripes and markings; hot thermo plastic; tape traffic stripes and markings, including traffic control; operation of all related machinery and equipment

* PAIN0036-001 01/01/2011

Rates Fringes

Painters: (Including Lead Abatement)

(1) Repaint.....\$ 26.05 10.08
(2) All Other Work.....\$ 29.32 10.08

REPAINT of any previously painted structure. Exceptions:

work involving the aerospace industry, breweries, commercial recreational facilities, hotels which operate commercial establishments as part of hotel service, and sports facilities.

PAIN0036-008 01/06/2010

Rates Fringes

DRYWALL FINISHER/TAPER.....\$ 33.22 12.19

* PAIN0036-015 01/01/2011

Rates Fringes

GLAZIER.....\$ 36.90 21.78

FOOTNOTE: Additional \$1.25 per hour for work in a condor, from the third (3rd) floor and up Additional \$1.25 per hour for work on the outside of the building from a swing stage or any suspended contrivance, from the ground up

PAIN1247-002 01/01/2010

Rates Fringes

SOFT FLOOR LAYER.....\$ 30.85 10.54

PLAS0200-009 08/04/2010

Rates Fringes

PLASTERER.....\$ 30.21 14.23

PLAS0500-002 07/01/2010

Rates Fringes

CEMENT MASON/CONCRETE FINISHER...\$ 29.50 19.85

* PLUM0016-001 07/01/2010

Rates Fringes

PLUMBER/PIPEFITTER

(1) Work on strip malls, light commercial, tenant improvement and remodel work.....\$ 30.32 14.98

(2) Work on new additions and remodeling of bars, restaurant, stores and commercial buildings not to exceed 5,000 sq. ft. of floor space.....\$ 37.74 16.66

(3) All other work.....\$ 38.92 17.64

* PLUM0345-001 07/01/2010

Rates Fringes

PLUMBER

Landscape/Irrigation Fitter.\$ 27.35 14.59

Sewer & Storm Drain Work...\$ 26.43 16.47

ROOF0036-002 08/01/2010

Rates Fringes

ROOFER.....\$ 34.65 9.07

FOOTNOTE: Pitch premium: Work on which employees are exposed to pitch fumes or required to handle pitch, pitch base or pitch impregnated products, or any material containing coal tar pitch, the entire roofing crew shall receive \$1.75 per hour "pitch premium" pay.

SFCA0669-002 04/01/2010

Rates Fringes

SPRINKLER FITTER.....\$ 33.35 17.60

* SHEE0105-003 01/01/2011

LOS ANGELES (South of a straight line drawn between Gorman and Big Pines) and Catalina Island, INYO, KERN (Northeast part, East of Hwy 395), MONO ORANGE, RIVERSIDE, AND SAN BERNARDINO COUNTIES
Rates Fringes

SHEET METAL WORKER

(1) Commercial - New
Construction and Remodel
work.....\$ 42.54 17.87

(2) Industrial work
including air pollution
control systems, noise
abatement, hand rails,
guard rails, excluding
aritechtural sheet metal
work, excluding A-C,
heating, ventilating
systems for human comfort...\$ 36.92 23.79

TEAM0011-002 07/01/2008

Rates Fringes

TRUCK DRIVER

GROUP 1.....\$ 26.44 18.24
GROUP 2.....\$ 26.59 18.24
GROUP 3.....\$ 26.72 18.24
GROUP 4.....\$ 26.91 18.24
GROUP 5.....\$ 26.94 18.24
GROUP 6.....\$ 26.97 18.24
GROUP 7.....\$ 27.22 18.24
GROUP 8.....\$ 27.47 18.24
GROUP 9.....\$ 27.67 18.24
GROUP 10.....\$ 27.97 18.24
GROUP 11.....\$ 28.47 18.24
GROUP 12.....\$ 28.90 18.24

WORK ON ALL MILITARY BASES:

PREMIUM PAY: \$3.00 per hour additional.
[29 palms Marine Base, Camp Roberts, China Lake, Edwards AFB,
El Centro Naval Facility, Fort Irwin, Marine Corps
Logistics Base at Nebo & Yermo, Mountain Warfare Training
Center, Bridgeport, Point Arguello, Point Conception,
Vandenberg AFB]

TRUCK DRIVERS CLASSIFICATIONS

GROUP 1: Truck driver

GROUP 2: Driver of vehicle or combination of vehicles - 2 axles; Traffic control pilot car excluding moving heavy equipment permit load; Truck mounted broom

GROUP 3: Driver of vehicle or combination of vehicles - 3 axles; Boot person; Cement mason distribution truck; Fuel truck driver; Water truck - 2 axle; Dump truck, less than 16 yds. water level; Erosion control driver

GROUP 4: Driver of transit mix truck, under 3 yds.; Dumpcrete truck, less than 6-1/2 yds. water level

GROUP 5: Water truck, 3 or more axles; Truck greaser and tire person (\$0.50 additional for tire person); Pipeline and utility working truck driver, including winch truck and

plastic fusion, limited to pipeline and utility work;
Slurry truck driver

GROUP 6: Transit mix truck, 3 yds. or more; Dumpcrete truck, 6-1/2 yds. water level and over; Vehicle or combination of vehicles - 4 or more axles; Oil spreader truck; Dump truck, 16 yds. to 25 yds. water level

GROUP 7: A Frame, Swedish crane or similar; Forklift driver; Ross carrier driver

GROUP 8: Dump truck, 25 yds. to 49 yds. water level; Truck repair person; Water pull - single engine; Welder

GROUP 9: Truck repair person/welder; Low bed driver, 9 axles or over

GROUP 10: Dump truck - 50 yds. or more water level; Water pull - single engine with attachment

GROUP 11: Water pull - twin engine; Water pull - twin engine with attachments; Winch truck driver - \$1.25 additional when operating winch or similar special attachments

GROUP 12: Boom Truck 17K and above

WELDERS - Receive rate prescribed for craft performing operation to which welding is incidental.

=====
Unlisted classifications needed for work not included within the scope of the classifications listed may be added after award only as provided in the labor standards contract clauses (29CFR 5.5 (a) (1) (ii)).

In the listing above, the "SU" designation means that rates listed under the identifier do not reflect collectively bargained wage and fringe benefit rates. Other designations indicate unions whose rates have been determined to be prevailing.

WAGE DETERMINATION APPEALS PROCESS

1.) Has there been an initial decision in the matter? This can be:

- * an existing published wage determination
 - * a survey underlying a wage determination
 - * a Wage and Hour Division letter setting forth a position on a wage determination matter
 - * a conformance (additional classification and rate) ruling
- On survey related matters, initial contact, including requests for summaries of surveys, should be with the Wage and Hour Regional Office for the area in which the survey was conducted because those Regional Offices have responsibility for the Davis-Bacon survey program. If the response from this initial contact is not satisfactory, then the process described in 2.) and 3.) should be followed.

With regard to any other matter not yet ripe for the formal process described here, initial contact should be with the Branch of Construction Wage Determinations. Write to:

Branch of Construction Wage Determinations
Wage and Hour Division

U.S. Department of Labor
200 Constitution Avenue, N.W.
Washington, DC 20210

2.) If the answer to the question in 1.) is yes, then an interested party (those affected by the action) can request review and reconsideration from the Wage and Hour Administrator (See 29 CFR Part 1.8 and 29 CFR Part 7). Write to:

Wage and Hour Administrator
U.S. Department of Labor
200 Constitution Avenue, N.W.
Washington, DC 20210

The request should be accompanied by a full statement of the interested party's position and by any information (wage payment data, project description, area practice material, etc.) that the requestor considers relevant to the issue.

3.) If the decision of the Administrator is not favorable, an interested party may appeal directly to the Administrative Review Board (formerly the Wage Appeals Board). Write to:

Administrative Review Board
U.S. Department of Labor
200 Constitution Avenue, N.W.
Washington, DC 20210

4.) All decisions by the Administrative Review Board are final.

=====

END OF GENERAL DECISION

SECTION 6
FEDERAL REQUIREMENTS FOR FEDERAL AID
CONSTRUCTION PROJECTS

SECTION 6. FEDERAL REQUIREMENTS FOR FEDERAL-AID CONSTRUCTION PROJECTS

GENERAL.—The work herein proposed will be financed in whole or in part with Federal funds, and therefore all of the statutes, rules and regulations promulgated by the Federal Government and applicable to work financed in whole or in part with Federal funds will apply to such work. The "Required Contract Provisions, Federal-Aid Construction Contracts, "Form FHWA 1273, are included in this Section 14. Whenever in said required contract provisions references are made to "SHA contracting officer," "SHA resident engineer," or "authorized representative of the SHA," such references shall be construed to mean "Engineer" as defined in Section 1-1.18 of the Standard Specifications.

PERFORMANCE OF PREVIOUS CONTRACT.—In addition to the provisions in Section II, "Nondiscrimination," and Section VII, "Subletting or Assigning the Contract," of the required contract provisions, the Contractor shall comply with the following:

The bidder shall execute the CERTIFICATION WITH REGARD TO THE PERFORMANCE OF PREVIOUS CONTRACTS OR SUBCONTRACTS SUBJECT TO THE EQUAL OPPORTUNITY CLAUSE AND THE FILING OF REQUIRED REPORTS located in the proposal. No request for subletting or assigning any portion of the contract in excess of \$10,000 will be considered under the provisions of Section VII of the required contract provisions unless such request is accompanied by the CERTIFICATION referred to above, executed by the proposed subcontractor.

NON-COLLUSION PROVISION.—The provisions in this section are applicable to all contracts except contracts for Federal Aid Secondary projects.

Title 23, United States Code, Section 112, requires as a condition precedent to approval by the Federal Highway Administrator of the contract for this work that each bidder file a sworn statement executed by, or on behalf of, the person, firm, association, or corporation to whom such contract is to be awarded, certifying that such person, firm, association, or corporation has not, either directly or indirectly, entered into any agreement, participated in any collusion, or otherwise taken any action in restraint of free competitive bidding in connection with the submitted bid. A form to make the non-collusion affidavit statement required by Section 112 as a certification under penalty of perjury rather than as a sworn statement as permitted by 28, USC, Sec. 1746, is included in the proposal.

PARTICIPATION BY DISADVANTAGED BUSINESS ENTERPRISES IN SUBCONTRACTING.—Part 26, Title 49, Code of Federal Regulations applies to this Federal-aid project. Pertinent sections of said Code are incorporated in part or in its entirety within other sections of these special provisions.

Schedule B—Information for Determining Joint Venture Eligibility

(This form need not be filled in if all joint venture firms are DBE owned.)

1. Name of joint venture _____

2. Address of joint venture _____

3. Phone number of joint venture _____

4. Identify the firms which comprise the joint venture. (The DBE partner must complete Schedule A.) _____

a. Describe the role of the DBE firm in the joint venture.

b. Describe very briefly the experience and business qualifications of each non-DBE joint venturer: _____

5. Nature of the joint venture's business _____

6. Provide a copy of the joint venture agreement.

7. What is the claimed percentage of DBE ownership? _____

8. Ownership of joint venture: (This need not be filled in if described in the joint venture agreement, provided by question 6.)

- a. Profit and loss sharing.
- b. Capital contributions, including equipment.
- c. Other applicable ownership interests.

9. Control of and participation in this contract. Identify by name, race, sex, and "firm" those individuals (and their titles) who are responsible for day-to-day management and policy decision making, including, but not limited to, those with prime responsibility for:

a. Financial decisions _____

b. Management decisions, such as:

1. Estimating _____

2. Marketing and sales _____

3. Hiring and firing of management personnel _____

4. Purchasing of major items or supplies _____

c. Supervision of field operations _____

Note.—If, after filing this Schedule B and before the completion of the joint venture's work on the contract covered by this regulation, there is any significant change in the information submitted, the joint venture must inform the grantee, either directly or through the prime contractor if the joint venture is a subcontractor.

Affidavit

"The undersigned swear that the foregoing statements are correct and include all material information necessary to identify and explain the terms and operation of our joint venture and the intended participation by each joint venturer in the undertaking. Further, the undersigned covenant and agree to provide to grantee current, complete and accurate information regarding actual joint venture work and the payment therefor and any proposed changes in any of the joint venture arrangements and to permit the audit and examination of the books, records and files of the joint venture, or those of each joint venturer relevant to the joint venture, by authorized representatives of the grantee or the Federal funding agency. Any material misrepresentation will be grounds for terminating any contract which may be awarded and for initiating action under Federal or State laws concerning false statements."

Revised 3-95
08-07-95

..... Name of Firm Name of Firm
..... Signature Signature
..... Name Name
..... Title Title
..... Date Date

Date _____

State of _____

County of _____

On this ___ day of _____, 19 __, before me appeared (Name) _____, to me personally known, who, being duly sworn, did execute the foregoing affidavit, and did state that he or she was properly authorized by (Name of firm) _____ to execute the affidavit and did so as his or her free act and deed.

Notary Public _____

Commission expires _____

[Seal]

Date _____

State of _____

County of _____

On this ___ day of _____, 19 __, before me appeared (Name) _____ to me personally known, who, being duly sworn, did execute the foregoing affidavit, and did state that he or she was properly authorized by (Name of firm) _____ to execute the affidavit and did so as his or her free act and deed.

Notary Public _____

Commission expires _____

[Seal]

**REQUIRED CONTRACT PROVISIONS
FEDERAL-AID CONSTRUCTION CONTRACTS**

(Exclusive of Appalachian Contracts)

	Page
I. General	3
II. Nondiscrimination	3
III. Nonsegregated Facilities	5
IV. Payment of Predetermined Minimum Wage	6
V. Statements and Payrolls	8
VI. Record of Materials, Supplies, and Labor	9
VII. Subletting or Assigning the Contract	9
VIII. Safety: Accident Prevention	10
IX. False Statements Concerning Highway Project	10
X. Implementation of Clean Air Act and Federal Water Pollution Control Act.....	10
XI. Certification Regarding Debarment, Suspension, Ineligibility, and Voluntary Exclusion	11
XII. Certification Regarding Use of Contract Funds for Lobbying	12

6. Selection of Labor: During the performance of this contract, the contractor shall not:

a. discriminate against labor from any other State, possession, or territory of the United States (except for employment preference for Appalachian contracts, when applicable, as specified in Attachment A), or

b. employ convict labor for any purpose within the limits of the project unless it is labor performed by convicts who are on parole, supervised release, or probation.

II. NONDISCRIMINATION

(Applicable to all Federal-aid construction contracts and to all related subcontracts of \$10,000 or more.)

1. Equal Employment Opportunity: Equal employment opportunity (EEO) requirements not to discriminate and to take affirmative action to assure equal opportunity as set forth under laws, executive orders, rules, regulations (28 CFR 35, 29 CFR 1630, and 41 CFR 60) and orders of the Secretary of Labor as modified by the provisions prescribed herein, and imposed pursuant to 23 U.S.C. 140 shall constitute the EEO and specific affirmative action standards for the contractor's project activities under this contract. The Equal Opportunity Construction Contract Specifications set forth under 41 CFR 60-4.3 and the provisions of the American Disabilities Act of 1990 (42 U.S.C. 12101 et seq.) set forth under 28 CFR 35 and 29 CFR 1630 are incorporated by reference in this contract. In the execution of this contract, the contractor agrees to comply with the following minimum specific requirement activities of EEO:

a. The contractor will work with the State highway agency (SHA) and the Federal Government in carrying out EEO obligations and in their review of his/her activities under the contract.

b. The contractor will accept as his operating policy the following statement:

"It is the policy of this Company to assure that applicants are employed, and that employees are treated during employment, without regard to their race, religion, sex, color, national origin, age or disability. Such action shall include: employment, upgrading, demotion, or transfer; recruitment or recruitment advertising; layoff or termination; rates of pay or other forms of compensation; and selection for training, including apprenticeship, preapprenticeship, and/or on-the-job training."

2. EEO Officer: The contractor will designate and make known to the SHA contracting officers an EEO Officer who will have the responsibility for and must be capable of effectively

ATTACHMENTS

A. Employment Preference for Appalachian Contracts (included in Appalachian contracts only)

I. GENERAL

1. These contract provisions shall apply to all work performed on the contract by the contractor's own organization and with the assistance of workers under the contractor's immediate superintendence and to all work performed on the contract by piecework, station work, or by subcontract.

2. Except as otherwise provided for in each section, the contractor shall insert in each subcontract all of the stipulations contained in these Required Contract Provisions, and further require their inclusion in any lower tier subcontract or purchase order that may in turn be made. The Required Contract Provisions shall not be incorporated by reference in any case. The prime contractor shall be responsible for compliance by any subcontractor or lower tier subcontractor with these Required Contract Provisions.

3. A breach of any of the stipulations contained in these Required Contract Provisions shall be sufficient grounds for termination of the contract.

4. A breach of the following clauses of the Required Contract Provisions may also be grounds for debarment as provided in 29 CFR 5.12:

- Section I, paragraph 2;
- Section IV, paragraphs 1, 2, 3, 4, and 7;
- Section V, paragraphs 1 and 2a through 2g.

5. Disputes arising out of the labor standards provisions of Section IV (except paragraph 5) and Section V of these Required Contract Provisions shall not be subject to the general disputes clause of this contract. Such disputes shall be resolved in accordance with the procedures of the U.S. Department of Labor (DOL) as set forth in 29 CFR 5, 6, and 7. Disputes within the meaning of this clause include disputes between the contractor (or any of its subcontractors) and the contracting agency, the DOL, or the contractor's employees or their representatives.

FR-3

administering and promoting an active contractor program of EEO and who must be assigned adequate authority and responsibility to do so.

3. Dissemination of Policy: All members of the contractor's staff who are authorized to hire, supervise, promote, and discharge employees, or who recommend such action, or who are substantially involved in such action, will be made fully cognizant of, and will implement, the contractor's EEO policy and contractual responsibilities to provide EEO in each grade and classification of employment. To ensure that the above agreement will be met, the following actions will be taken as a minimum:

a. Periodic meetings of supervisory and personnel office employees will be conducted before the start of work and then not less often than once every six months, at which time the contractor's EEO policy and its implementation will be reviewed and explained. The meetings will be conducted by the EEO Officer.

b. All new supervisory or personnel office employees will be given a thorough indoctrination by the EEO Officer, covering all major aspects of the contractor's EEO obligations within thirty days following their reporting for duty with the contractor.

c. All personnel who are engaged in direct recruitment for the project will be instructed by the EEO Officer in the contractor's procedures for locating and hiring minority group employees.

d. Notices and posters setting forth the contractor's EEO policy will be placed in areas readily accessible to employees, applicants for employment and potential employees.

e. The contractor's EEO policy and the procedures to implement such policy will be brought to the attention of employees by means of meetings, employee handbooks, or other appropriate means.

4. Recruitment: When advertising for employees, the contractor will include in all advertisements for employees the notation: "An Equal Opportunity Employer." All such advertisements will be placed in publications having a large circulation among minority groups in the area from which the project work force would normally be derived.

a. The contractor will, unless precluded by a valid bargaining agreement, conduct systematic and direct recruitment through public and private employee referral sources likely to yield qualified minority group applicants. To meet this requirement, the contractor will identify sources of potential minority group employees, and establish with such identified sources procedures whereby minority group applicants may be referred to the contractor for employment consideration.

b. In the event the contractor has a valid bargaining agreement providing for exclusive hiring hall referrals, he is expected to observe the provisions of that agreement to the extent that the system permits the contractor's compliance with EEO contract provisions. (The DOL has held that where implementation of such agreements have the effect of discriminating against minorities or women, or obligates the contractor to do the same, such implementation violates Executive Order 11246, as amended.)

c. The contractor will encourage his present employees to refer minority group applicants for employment. Information and procedures with regard to referring minority group applicants will be discussed with employees.

5. Personnel Actions: Wages, working conditions, and employee benefits shall be established and administered, and personnel actions of every type, including hiring, upgrading, promotion, transfer, demotion, layoff, and termination, shall be taken without regard to race, color, religion, sex, national origin, age or disability. The following procedures shall be followed:

a. The contractor will conduct periodic inspections of project sites to ensure that working conditions and employee facilities do not indicate discriminatory treatment of project site personnel.

b. The contractor will periodically evaluate the spread of wages paid within each classification to determine any evidence of discriminatory wage practices.

c. The contractor will periodically review selected personnel actions in depth to determine whether there is evidence of discrimination. Where evidence is found, the contractor will promptly take corrective action. If the review indicates that the discrimination may extend beyond the actions reviewed, such corrective action shall include all affected persons.

d. The contractor will promptly investigate all complaints of alleged discrimination made to the contractor in connection with his obligations under this contract, will attempt to resolve such complaints, and will take appropriate corrective action within a reasonable time. If the investigation indicates that the discrimination may affect persons other than the complainant, such corrective action shall include such other persons. Upon completion of each investigation, the contractor will inform every complainant of all of his avenues of appeal.

6. Training and Promotion:

a. The contractor will assist in locating, qualifying, and increasing the skills of minority group and women employees, and applicants for employment.

b. Consistent with the contractor's work force requirements and as permissible under Federal and State regulations, the contractor shall make full use of training programs, i.e., apprenticeship, and on-the-job training programs for the geographical area of contract performance. Where feasible, 25 percent of apprentices or trainees in each occupation shall be in their first year of apprenticeship or training. In the event a special provision for training is provided under this contract, this subparagraph will be superseded as indicated in the special provision.

c. The contractor will advise employees and applicants for employment of available training programs and entrance requirements for each.

d. The contractor will periodically review the training and promotion potential of minority group and women employees and will encourage eligible employees to apply for such training and promotion.

7. Unions: If the contractor relies in whole or in part upon unions as a source of employees, the contractor will use his/her best efforts to obtain the cooperation of such unions to increase opportunities for minority groups and women within the unions, and to effect referrals by such unions of minority and female employees. Actions by the contractor either directly or through a contractor's association acting as agent will include the procedures set forth below:

a. The contractor will use best efforts to develop, in cooperation with the unions, joint training programs aimed toward qualifying more minority group members and women for membership in the unions and increasing the skills of minority group employees and women so that they may qualify for higher paying employment.

b. The contractor will use best efforts to incorporate an EEO clause into each union agreement to the end that such union will be contractually bound to refer applicants without regard to their race, color, religion, sex, national origin, age or disability.

c. The contractor is to obtain information as to the referral practices and policies of the labor union except that to the extent such information is within the exclusive possession of the labor union and such labor union refuses to furnish such information to the contractor, the contractor shall so certify to the SHA and shall set forth what efforts have been made to obtain such information.

d. In the event the union is unable to provide the contractor with a reasonable flow of minority and women referrals within the time limit set forth in the collective bargaining agreement, the contractor will, through independent recruitment efforts, fill the employment vacancies without regard to race, color, religion, sex, national origin, age or disability; making full efforts to obtain qualified and/or qualifiable minority group persons and women. (The DOL has held that it shall be no excuse that the union with which the contractor has a collective bargaining agreement providing for exclusive referral failed to refer minority employees.) In the event the union referral practice prevents the contractor from meeting the obligations pursuant to Executive Order 11246, as amended, and these special provisions, such contractor shall immediately notify the SHA.

8. Selection of Subcontractors, Procurement of Materials and Leasing of Equipment: The contractor shall not discriminate on the grounds of race, color, religion, sex, national origin, age or disability in the selection and retention of subcontractors, including procurement of materials and leases of equipment.

a. The contractor shall notify all potential subcontractors and suppliers of his/her EEO obligations under this contract.

b. Disadvantaged business enterprises (DBE), as defined in 49 CFR 26, shall have equal opportunity to compete for and perform subcontracts which the contractor enters into pursuant to this contract. The contractor will use his best efforts to solicit bids from and to utilize DBE subcontractors or subcontractors with meaningful minority group and female representation among their employees. Contractors shall obtain lists of DBE construction firms from SHA personnel.

c. The contractor will use his best efforts to ensure subcontractor compliance with their EEO obligations.

9. Records and Reports: The contractor shall keep such

records as necessary to document compliance with the EEO requirements. Such records shall be retained for a period of three years following completion of the contract work and shall be available at reasonable times and places for inspection by authorized representatives of the SHA and the FHWA.

a. The records kept by the contractor shall document the following:

(1) The number of minority and non-minority group members and women employed in each work classification on the project;

(2) The progress and efforts being made in cooperation with unions, when applicable, to increase employment opportunities for minorities and women;

(3) The progress and efforts being made in locating, hiring, training, qualifying, and upgrading minority and female employees; and

(4) The progress and efforts being made in securing the services of DBE subcontractors or subcontractors with meaningful minority and female representation among their employees.

b. The contractors will submit an annual report to the SHA each July for the duration of the project, indicating the number of minority, women, and non-minority group employees currently engaged in each work classification required by the contract work. This information is to be reported on Form FHWA-1391. If on-the-job training is being required by special provision, the contractor will be required to collect and report training data.

III NONSEGREGATED FACILITIES

(Applicable to all Federal-aid construction contracts and to all related subcontracts of \$10,000 or more.)

a. By submission of this bid, the execution of this contract or subcontract, or the consummation of this material supply agreement or purchase order, as appropriate, the bidder, Federal-aid construction contractor, subcontractor, material supplier, or vendor, as appropriate, certifies that the firm does not maintain or provide for its employees any segregated facilities at any of its establishments, and that the firm does not permit its employees to perform their services at any location, under its control, where segregated facilities are maintained. The firm agrees that a breach of this certification is a violation of the EEO provisions of this contract. The firm further certifies that no employee will be denied access to adequate facilities on the basis of sex or disability.

b. As used in this certification, the term "segregated facilities" means any waiting rooms, work areas, restrooms and washrooms, restaurants and other eating areas, time clocks, locker rooms, and other storage or dressing areas, parking lots, drinking fountains, recreation or entertainment areas, transportation, and housing facilities provided for employees which are segregated by explicit directive, or are, in fact, segregated on the basis of race, color, religion, national origin, age or disability, because of habit, local custom, or otherwise. The only exception will be for the disabled when the demands for accessibility override (e.g. disabled parking).

c. The contractor agrees that it has obtained or will obtain identical certification from proposed subcontractors or material suppliers prior to award of subcontracts or consummation of material supply agreements of \$10,000 or more and that it will retain such certifications in its files.

IV. PAYMENT OF PREDETERMINED MINIMUM WAGE

(Applicable to all Federal-aid construction contracts exceeding \$2,000 and to all related subcontracts, except for projects located on roadways classified as local roads or rural minor collectors, which are exempt.)

1. General:

a. All mechanics and laborers employed or working upon the site of the work will be paid unconditionally and not less often than once a week and without subsequent deduction or rebate on any account [except such payroll deductions as are permitted by regulations (29 CFR 3)] issued by the Secretary of Labor under the Copeland Act (40 U.S.C. 276c) the full amounts of wages and bona fide fringe benefits (or cash equivalents thereof) due at time of payment. The payment shall be computed at wage rates not less than those contained in the wage determination of the Secretary of Labor (hereinafter "the wage determination") which is attached hereto and made a part hereof, regardless of any contractual relationship which may be alleged to exist between the contractor or its subcontractors and such laborers and mechanics. The wage determination (including any additional classifications and wage rates conformed under paragraph 2 of this Section IV and the DOL poster (WH-1321) or Form FHWA-1495) shall be posted at all times by the contractor and its subcontractors at the site of the work in a prominent and accessible place where it can be easily seen by the workers. For the purpose of this Section, contributions made or costs reasonably anticipated for bona fide fringe benefits under Section 1(b)(2) of the Davis-Bacon Act (40 U.S.C. 276a) on behalf of laborers or mechanics are considered wages paid to such laborers or mechanics, subject to the provisions of Section IV, paragraph 3b, hereof. Also, for the purpose of this Section, regular contributions made or costs incurred for more than a weekly period (but not less often than quarterly) under plans, funds, or programs, which cover the particular weekly period, are deemed to be constructively made or incurred during such weekly period. Such laborers and mechanics shall be paid the appropriate wage rate and fringe benefits on the wage determination for the classification of work actually performed, without regard to skill, except as provided in paragraphs 4 and 5 of this Section IV.

b. Laborers or mechanics performing work in more than one classification may be compensated at the rate specified for each classification for the time actually worked therein, provided, that the employer's payroll records accurately set forth the time spent in each classification in which work is performed.

c. All rulings and interpretations of the Davis-Bacon Act and related acts contained in 29 CFR 1, 3, and 5 are herein incorporated by reference in this contract.

2. Classification:

a. The SHA contracting officer shall require that any class of laborers or mechanics employed under the contract, which is not listed in the wage determination, shall be classified in conformance with the wage determination.

b. The contracting officer shall approve an additional classification, wage rate and fringe benefits only when the following criteria have been met:

(1) the work to be performed by the additional classification requested is not performed by a classification in the wage determination;

(2) the additional classification is utilized in the area by the construction industry;

(3) the proposed wage rate, including any bona fide fringe benefits, bears a reasonable relationship to the wage rates contained in the wage determination; and

(4) with respect to helpers, when such a classification prevails in the area in which the work is performed.

c. If the contractor or subcontractors, as appropriate, the laborers and mechanics (if known) to be employed in the additional classification or their representatives, and the contracting officer agree on the classification and wage rate (including the amount designated for fringe benefits where appropriate), a report of the action taken shall be sent by the contracting officer to the DOL, Administrator of the Wage and Hour Division, Employment Standards Administration, Washington, D.C. 20210. The Wage and Hour Administrator, or an authorized representative, will approve, modify, or disapprove every additional classification action within 30 days of receipt and so advise the contracting officer or will notify the contracting officer within the 30-day period that additional time is necessary.

d. In the event the contractor or subcontractors, as appropriate, the laborers or mechanics to be employed in the additional classification or their representatives, and the contracting officer do not agree on the proposed classification and wage rate (including the amount designated for fringe benefits, where appropriate), the contracting officer shall refer the questions, including the views of all interested parties and the recommendation of the contracting officer, to the Wage and Hour Administrator for determination. Said Administrator, or an authorized representative, will issue a determination within 30 days of receipt and so advise the contracting officer or will notify the contracting officer within the 30-day period that additional time is necessary.

e. The wage rate (including fringe benefits where appropriate) determined pursuant to paragraph 2c or 2d of this Section IV shall be paid to all workers performing work in the additional classification from the first day on which work is performed in the classification.

3. Payment of Fringe Benefits:

a. Whenever the minimum wage rate prescribed in the contract for a class of laborers or mechanics includes a fringe benefit which is not expressed as an hourly rate, the contractor or subcontractors, as appropriate, shall either pay the benefit

as stated in the wage determination or shall pay another bona fide fringe benefit or an hourly case equivalent thereof.

b. If the contractor or subcontractor, as appropriate, does not make payments to a trustee or other third person, he/she may consider as a part of the wages of any laborer or mechanic the amount of any costs reasonably anticipated in providing bona fide fringe benefits under a plan or program, provided, that the Secretary of Labor has found, upon the written request of the contractor, that the applicable standards of the Davis-Bacon Act have been met. The Secretary of Labor may require the contractor to set aside in a separate account assets for the meeting of obligations under the plan or program.

4. Apprentices and Trainees (Programs of the U.S. DOL) and Helpers:

a. Apprentices:

(1) Apprentices will be permitted to work at less than the predetermined rate for the work they performed when they are employed pursuant to and individually registered in a bona fide apprenticeship program registered with the DOL, Employment and Training Administration, Bureau of Apprenticeship and Training, or with a State apprenticeship agency recognized by the Bureau, or if a person is employed in his/her first 90 days of probationary employment as an apprentice in such an apprenticeship program, who is not individually registered in the program, but who has been certified by the Bureau of Apprenticeship and Training or a State apprenticeship agency (where appropriate) to be eligible for probationary employment as an apprentice.

(2) The allowable ratio of apprentices to journeyman-level employees on the job site in any craft classification shall not be greater than the ratio permitted to the contractor as to the entire work force under the registered program. Any employee listed on a payroll at an apprentice wage rate, who is not registered or otherwise employed as stated above, shall be paid not less than the applicable wage rate listed in the wage determination for the classification of work actually performed. In addition, any apprentice performing work on the job site in excess of the ratio permitted under the registered program shall be paid not less than the applicable wage rate on the wage determination for the work actually performed. Where a contractor or subcontractor is performing construction on a project in a locality other than that in which its program is registered, the ratios and wage rates (expressed in percentages of the journeyman-level hourly rate) specified in the contractor's or subcontractor's registered program shall be observed.

(3) Every apprentice must be paid at not less than the rate specified in the registered program for the apprentice's level of progress, expressed as a percentage of the journeyman-level hourly rate specified in the applicable wage determination. Apprentices shall be paid fringe benefits in accordance with the provisions of the apprenticeship program. If the apprenticeship program does not specify fringe benefits, apprentices must be paid the full amount of fringe benefits listed on the wage determination for the applicable classification. If the Administrator for the Wage and Hour Division determines that a different practice prevails for the applicable apprentice classification, fringes shall be paid in accordance with that determination.

(4) In the event the Bureau of Apprenticeship and Training, or a State apprenticeship agency recognized by the Bureau, withdraws approval of an apprenticeship program, the contractor or subcontractor will no longer be permitted to utilize apprentices at less than the applicable predetermined rate for the comparable work performed by regular employees until an acceptable program is approved.

b. Trainees:

(1) Except as provided in 29 CFR 5.16, trainees will not be permitted to work at less than the predetermined rate for the work performed unless they are employed pursuant to and individually registered in a program which has received prior approval, evidenced by formal certification by the DOL, Employment and Training Administration.

(2) The ratio of trainees to journeyman-level employees on the job site shall not be greater than permitted under the plan approved by the Employment and Training Administration. Any employee listed on the payroll at a trainee rate who is not registered and participating in a training plan approved by the Employment and Training Administration shall be paid not less than the applicable wage rate on the wage determination for the classification of work actually performed. In addition, any trainee performing work on the job site in excess of the ratio permitted under the registered program shall be paid not less than the applicable wage rate on the wage determination for the work actually performed.

(3) Every trainee must be paid at not less than the rate specified in the approved program for his/her level of progress, expressed as a percentage of the journeyman-level hourly rate specified in the applicable wage determination. Trainees shall be paid fringe benefits in accordance with the provisions of the trainee program. If the trainee program does not mention fringe benefits, trainees shall be paid the full amount of fringe benefits listed on the wage determination unless the Administrator of the Wage and Hour Division determines that there is an apprenticeship program associated with the corresponding journeyman-level wage rate on the wage determination which provides for less than full fringe benefits for apprentices, in which case such trainees shall receive the same fringe benefits as apprentices.

(4) In the event the Employment and Training Administration withdraws approval of a training program, the contractor or subcontractor will no longer be permitted to utilize trainees at less than the applicable predetermined rate for the work performed until an acceptable program is approved.

c. Helpers:

Helpers will be permitted to work on a project if the helper classification is specified and defined on the applicable wage determination or is approved pursuant to the conformance procedure set forth in Section IV.2. Any worker listed on a payroll at a helper wage rate, who is not a helper under an approved definition, shall be paid not less than the applicable wage rate on the wage determination for the classification of work actually performed.

5. Apprentices and Trainees (Programs of the U.S. DOT):

Apprentices and trainees working under apprenticeship and skill training programs which have been certified by the Secretary of Transportation as promoting EEO in connection with Federal-aid highway construction programs are not subject to the requirements of paragraph 4 of this Section IV. The straight time hourly wage rates for apprentices and trainees under such programs will be established by the particular programs. The ratio of apprentices and trainees to journeymen shall not be greater than permitted by the terms of the particular program.

6. Withholding:

The SHA shall upon its own action or upon written request of an authorized representative of the DOL withhold, or cause to be withheld, from the contractor or subcontractor under this contract or any other Federal contract with the same prime contractor, or any other federally-assisted contract subject to Davis-Bacon prevailing wage requirements which is held by the same prime contractor, as much of the accrued payments or advances as may be considered necessary to pay laborers and mechanics, including apprentices, trainees, and helpers, employed by the contractor or any subcontractor the full amount of wages required by the contract. In the event of failure to pay any laborer or mechanic, including any apprentice, trainee, or helper, employed or working on the site of the work, all or part of the wages required by the contract, the SHA contracting officer may, after written notice to the contractor, take such action as may be necessary to cause the suspension of any further payment, advance, or guarantee of funds until such violations have ceased.

7. Overtime Requirements:

No contractor or subcontractor contracting for any part of the contract work which may require or involve the employment of laborers, mechanics, watchmen, or guards (including apprentices, trainees, and helpers described in paragraphs 4 and 5 above) shall require or permit any laborer, mechanic, watchman, or guard in any workweek in which he/she is employed on such work, to work in excess of 40 hours in such workweek unless such laborer, mechanic, watchman, or guard receives compensation at a rate not less than one-and-one-half times his/her basic rate of pay for all hours worked in excess of 40 hours in such workweek.

8. Violation:

Liability for Unpaid Wages; Liquidated Damages: In the event of any violation of the clause set forth in paragraph 7 above, the contractor and any subcontractor responsible thereof shall be liable to the affected employee for his/her unpaid wages. In addition, such contractor and subcontractor shall be liable to the United States (in the case of work done under contract for the District of Columbia or a territory, to such District or to such territory) for liquidated damages. Such liquidated damages shall be computed with respect to each individual laborer, mechanic, watchman, or guard employed in violation of the clause set forth in paragraph 7, in the sum of \$10 for each calendar day on which such employee was required or permitted to work in excess of the standard work week of 40 hours without payment of the overtime wages required by the clause set forth in paragraph 7.

9. Withholding for Unpaid Wages and Liquidated Damages:

The SHA shall upon its own action or upon written request of any authorized representative of the DOL withhold, or cause to be withheld, from any moneys payable on account of work performed by the contractor or subcontractor under any such contract or any other Federal contract with the same prime contractor, or any other federally-assisted contract subject to the Contract Work Hours and Safety Standards Act, which is held by the same prime contractor, such sums as may be determined to be necessary to satisfy any liabilities of such contractor or subcontractor for unpaid wages and liquidated damages as provided in the clause set forth in paragraph 8 above.

V. STATEMENTS AND PAYROLLS

(Applicable to all Federal-aid construction contracts exceeding \$2,000 and to all related subcontracts, except for projects located on roadways classified as local roads or rural collectors, which are exempt.)

1. Compliance with Copeland Regulations (29 CFR 3):

The contractor shall comply with the Copeland Regulations of the Secretary of Labor which are herein incorporated by reference.

2. Payrolls and Payroll Records:

a. Payrolls and basic records relating thereto shall be maintained by the contractor and each subcontractor during the course of the work and preserved for a period of 3 years from the date of completion of the contract for all laborers, mechanics, apprentices, trainees, watchmen, helpers, and guards working at the site of the work.

b. The payroll records shall contain the name, social security number, and address of each such employee; his or her correct classification; hourly rates of wages paid (including rates of contributions or costs anticipated for bona fide fringe benefits or cash equivalent thereof of the types described in Section 1(b)(2)(B) of the Davis Bacon Act); daily and weekly number of hours worked; deductions made; and actual wages paid. In addition, for Appalachian contracts, the payroll records shall contain a notation indicating whether the employee does, or does not, normally reside in the labor area as defined in Attachment A, paragraph 1. Whenever the Secretary of Labor, pursuant to Section IV, paragraph 3b, has found that the wages of any laborer or mechanic include the amount of any costs reasonably anticipated in providing benefits under a plan or program described in Section 1(b)(2)(B) of the Davis Bacon Act, the contractor and each subcontractor shall maintain records which show that the commitment to provide such benefits is enforceable, that the plan or program is financially responsible, that the plan or program has been communicated in writing to the laborers or mechanics affected, and show the cost anticipated or the actual cost incurred in providing benefits. Contractors or subcontractors employing apprentices or trainees under approved programs shall maintain written evidence of the registration of apprentices and trainees, and ratios and wage rates prescribed in the applicable programs.

c. Each contractor and subcontractor shall furnish, each week in which any contract work is performed, to the SHA resident engineer a payroll of wages paid each of its employees (including apprentices, trainees, and helpers, described in Section IV, paragraphs 4 and 5, and watchmen and guards engaged on work during the preceding weekly payroll period). The payroll submitted shall set out accurately and completely all of the information required to be maintained under paragraph 2b of this Section V. This information may be submitted in any form desired. Optional Form WH-347 is available for this purpose and may be purchased from the Superintendent of Documents (Federal stock number 029-005-0014-1), U.S. Government Printing Office, Washington, D.C. 20402. The prime contractor is responsible for the submission of copies of payrolls by all subcontractors.

d. Each payroll submitted shall be accompanied by a "Statement of Compliance," signed by the contractor or subcontractor or his/her agent who pays or supervises the payment of the persons employed under the contract and shall certify the following:

(1) that the payroll for the payroll period contains the information required to be maintained under paragraph 2b of this Section V and that such information is correct and complete;

(2) that such laborer or mechanic (including each helper, apprentice, and trainee) employed on the contract during the payroll period has been paid the full weekly wages earned, without rebate, either directly or indirectly, and that no deductions have been made either directly or indirectly from the full wages earned, other than permissible deductions as set forth in the Regulations, 29 CFR 3;

(3) that each laborer or mechanic has been paid not less than the applicable wage rate and fringe benefits or cash equivalent for the classification of work performed, as specified in the applicable wage determination incorporated into the contract.

e. The weekly submission of a properly executed certification set forth on the reverse side of Optional Form WH-347 shall satisfy the requirement for submission of the "Statement of Compliance" required by paragraph 2d of this Section V.

f. The falsification of any of the above certifications may subject the contractor to civil or criminal prosecution under 18 U.S.C. 1001 and 31 U.S.C. 231.

g. The contractor or subcontractor shall make the records required under paragraph 2b of this Section V available for inspection, copying, or transcription by authorized representatives of the SHA, the FHWA, or the DOL, and shall permit such representatives to interview employees during working hours on the job. If the contractor or subcontractor fails to submit the required records or to make them available, the SHA, the FHWA, the DOL, or all may, after written notice to the contractor, sponsor, applicant, or owner, take such actions as may be necessary to cause the suspension of any further payment, advance, or guarantee of funds. Furthermore, failure to submit the required records upon request or to make such records available

may be grounds for debarment action pursuant to 29 CFR 5.12.

VI. RECORD OF MATERIALS, SUPPLIES, AND LABOR

1. On all Federal-aid contracts on the National Highway System, except those which provide solely for the installation of protective devices at railroad grade crossings, those which are constructed on a force account or direct labor basis, highway beautification contracts, and contracts for which the total final construction cost for roadway and bridge is less than \$1,000,000 (23 CFR 635); the contractor shall:

a. Become familiar with the list of specific materials and supplies contained in Form FHWA-47, "Statement of Materials and Labor Used by Contractor of Highway Construction Involving Federal Funds," prior to the commencement of work under this contract.

b. Maintain a record of the total cost of all materials and supplies purchased for and incorporated in the work, and also of the quantities of those specific materials and supplies listed on Form FHWA-47, and in the units shown on Form FHWA-47.

c. Furnish, upon the completion of the contract, to the SHA resident engineer on Form FHWA-47 together with the data required in paragraph 1b relative to materials and supplies, a final labor summary of all contract work indicating the total hours worked and the total amount earned.

2. At the prime contractor's option, either a single report covering all contract work or separate reports for the contractor and for each subcontract shall be submitted.

VII. SUBLETTING OR ASSIGNING THE CONTRACT

1. The contractor shall perform with its own organization contract work amounting to not less than 30 percent (or a greater percentage if specified elsewhere in the contract) of the total original contract price, excluding any specialty items designated by the State. Specialty items may be performed by subcontract and the amount of any such specialty items performed may be deducted from the total original contract price before computing the amount of work required to be performed by the contractor's own organization (23 CFR 635).

a. "Its own organization" shall be construed to include only workers employed and paid directly by the prime contractor and equipment owned or rented by the prime contractor, with or without operators. Such term does not include employees or equipment of a subcontractor, assignee, or agent of the prime contractor.

b. "Specialty Items" shall be construed to be limited to work that requires highly specialized knowledge, abilities, or equipment not ordinarily available in the type of contracting organizations qualified and expected to bid on the contract as a whole and in general are to be limited to minor components of the overall contract.

2. The contract amount upon which the requirements set forth in paragraph 1 of Section VII is computed includes the cost of material and manufactured products which are to be purchased or produced by the contractor under the contract provisions.

3. The contractor shall furnish (a) a competent superintendent or supervisor who is employed by the firm, has full authority to direct performance of the work in accordance with the contract requirements, and is in charge of all construction operations (regardless of who performs the work) and (b) such other of its own organizational resources (supervision, management, and engineering services) as the SHA contracting officer determines is necessary to assure the performance of the contract.

4. No portion of the contract shall be sublet, assigned or otherwise disposed of except with the written consent of the SHA contracting officer, or authorized representative, and such consent when given shall not be construed to relieve the contractor of any responsibility for the fulfillment of the contract. Written consent will be given only after the SHA has assured that each subcontract is evidenced in writing and that it contains all pertinent provisions and requirements of the prime contract.

VIII. SAFETY: ACCIDENT PREVENTION

1. In the performance of this contract the contractor shall comply with all applicable Federal, State, and local laws governing safety, health, and sanitation (23 CFR 635). The contractor shall provide all safeguards, safety devices and protective equipment and take any other needed actions as it determines, or as the SHA contracting officer may determine, to be reasonably necessary to protect the life and health of employees on the job and the safety of the public and to protect property in connection with the performance of the work covered by the contract.

2. It is a condition of this contract, and shall be made a condition of each subcontract, which the contractor enters into pursuant to this contract, that the contractor and any subcontractor shall not permit any employee, in performance of the contract, to work in surroundings or under conditions which are unsanitary, hazardous or dangerous to his/her health or safety, as determined under construction safety and health standards (29 CFR 1926) promulgated by the Secretary of Labor, in accordance with Section 107 of the Contract Work Hours and Safety Standards Act (40 U.S.C. 333).

3. Pursuant to 29 CFR 1926.3, it is a condition of this contract that the Secretary of Labor or authorized representative thereof, shall have right of entry to any site of contract performance to inspect or investigate the matter of compliance with the construction safety and health standards and to carry out the duties of the Secretary under Section 107 of the Contract Work Hours and Safety Standards Act (40 U.S.C. 333).

IX. FALSE STATEMENTS CONCERNING HIGHWAY PROJECTS

In order to assure high quality and durable construction in conformity with approved plans and specifications and a high degree of reliability on statements and representations made by engineers, contractors, suppliers, and workers on Federal-aid highway projects, it is essential that all persons concerned with the project perform their functions as carefully, thoroughly, and honestly as possible. Willful falsification, distortion, or misrepresentation with respect to any facts related to the project is a violation of Federal law. To prevent any misunderstanding re-
Form 1273 -- Revised 3-95
08-07-95

garding the seriousness of these and similar acts, the following notice shall be posted on each Federal-aid highway project (23 CFR 635) in one or more places where it is readily available to all persons concerned with the project:

NOTICE TO ALL PERSONNEL ENGAGED ON FEDERAL-AID HIGHWAY PROJECTS

18 U.S.C. 1020 reads as follows:

"Whoever being an officer, agent, or employee of the United States, or any State or Territory, or whoever, whether a person, association, firm, or corporation, knowingly makes any false statement, false representation, or false report as to the character, quality, quantity, or cost of the material used or to be used, or the quantity or quality of the work performed or to be performed, or the cost thereof in connection with the submission of plans, maps, specifications, contracts, or costs of construction on any highway or related project submitted for approval to the Secretary of Transportation; or

Whoever knowingly makes any false statement, false representation, false report or false claim with respect to the character, quality, quantity, or cost of any work performed or to be performed, or materials furnished or to be furnished, in connection with the construction of any highway or related project approved by the Secretary of Transportation; or

Whoever knowingly makes any false statement or false representation as to material fact in any statement, certificate, or report submitted pursuant to provisions of the Federal-aid Roads Act approved July 1, 1916, (39 Stat. 355), as amended and supplemented;

Shall be fined not more than \$10,000 or imprisoned not more than 5 years or both."

X. IMPLEMENTATION OF CLEAN AIR ACT AND FEDERAL WATER POLLUTION CONTROL ACT

(Applicable to all Federal-aid construction contracts and to all related subcontracts of \$100,000 or more.)

By submission of this bid or the execution of this contract, or subcontract, as appropriate, the bidder, Federal-aid construction contractor, or subcontractor, as appropriate, will be deemed to have stipulated as follows:

1. That any facility that is or will be utilized in the performance of this contract, unless such contract is exempt under the Clean Air Act, as amended (42 U.S.C. 1857 et seq., as amended by Pub. L. 91-604), and under the Federal Water Pollution Control Act, as amended (33 U.S.C. 1251 et seq., as amended by Pub. L. 92-500), Executive Order 11738, and regulations in implementation thereof (40 CFR 15) is not listed, on the date of contract award, on the U.S. Environmental Protection Agency (EPA) List of Violating Facilities pursuant to 40 CFR 15.20.

2. That the firm agrees to comply and remain in compliance with all the requirements of Section 114 of the Clean Air Act and Section 308 of the Federal Water Pollution Control Act and all regulations and guidelines listed thereunder.

3. That the firm shall promptly notify the SHA of the receipt of any communication from the Director, Office of Federal Activities, EPA, indicating that a facility that is or will be utilized

for the contract is under consideration to be listed on the EPA List of Violating Facilities.

4. That the firm agrees to include or cause to be included the requirements of paragraph 1 through 4 of this Section X in every nonexempt subcontract, and further agrees to take such action as the government may direct as a means of enforcing such requirements.

XI. CERTIFICATION REGARDING DEBARMENT, SUSPENSION, INELIGIBILITY AND VOLUNTARY EXCLUSION

1. Instructions for Certification - Primary Covered Transactions:

(Applicable to all Federal-aid contracts - 49 CFR 29)

a. By signing and submitting this proposal, the prospective primary participant is providing the certification set out below.

b. The inability of a person to provide the certification set out below will not necessarily result in denial of participation in this covered transaction. The prospective participant shall submit an explanation of why it cannot provide the certification set out below. The certification or explanation will be considered in connection with the department or agency's determination whether to enter into this transaction. However, failure of the prospective primary participant to furnish a certification or an explanation shall disqualify such a person from participation in this transaction.

c. The certification in this clause is a material representation of fact upon which reliance was placed when the department or agency determined to enter into this transaction. If it is later determined that the prospective primary participant knowingly rendered an erroneous certification, in addition to other remedies available to the Federal Government, the department or agency may terminate this transaction for cause of default.

d. The prospective primary participant shall provide immediate written notice to the department or agency to whom this proposal is submitted if any time the prospective primary participant learns that its certification was erroneous when submitted or has become erroneous by reason of changed circumstances.

e. The terms "covered transaction," "debarred," "suspended," "ineligible," "lower tier covered transaction," "participant," "person," "primary covered transaction," "principal," "proposal," and "voluntarily excluded," as used in this clause, have the meanings set out in the Definitions and Coverage sections of rules implementing Executive Order 12549. You may contact the department or agency to which this proposal is submitted for assistance in obtaining a copy of those regulations.

f. The prospective primary participant agrees by submitting this proposal that, should the proposed covered transaction be entered into, it shall not knowingly enter into any lower tier covered transaction with a person who is debarred, suspended, declared ineligible, or voluntarily excluded from participation in this covered transaction, unless authorized by the department or agency entering into this transaction.

g. The prospective primary participant further agrees by submitting this proposal that it will include the clause titled "Certification Regarding Debarment, Suspension, Ineligibility and Voluntary Exclusion-Lower Tier Covered Transaction," provided by the department or agency entering into this covered transaction, without modification, in all lower tier covered transactions and in all solicitations for lower tier covered transactions.

h. A participant in a covered transaction may rely upon a certification of a prospective participant in a lower tier covered transaction that is not debarred, suspended, ineligible, or voluntarily excluded from the covered transaction, unless it knows that the certification is erroneous. A participant may decide the method and frequency by which it determines the eligibility of its principals. Each participant may, but is not required to, check the nonprocurement portion of the "Lists of Parties Excluded From Federal Procurement or Nonprocurement Programs" (Nonprocurement List) which is compiled by the General Services Administration.

i. Nothing contained in the foregoing shall be construed to require establishment of a system of records in order to render in good faith the certification required by this clause. The knowledge and information of participant is not required to exceed that which is normally possessed by a prudent person in the ordinary course of business dealings.

j. Except for transactions authorized under paragraph f of these instructions, if a participant in a covered transaction knowingly enters into a lower tier covered transaction with a person who is suspended, debarred, ineligible, or voluntarily excluded from participation in this transaction, in addition to other remedies available to the Federal Government, the department or agency may terminate this transaction for cause or default.

* * * * *

Certification Regarding Debarment, Suspension, Ineligibility and Voluntary Exclusion—Primary Covered Transactions

1. The prospective primary participant certifies to the best of its knowledge and belief, that it and its principals:

a. Are not presently debarred, suspended, proposed for debarment, declared ineligible, or voluntarily excluded from covered transactions by any Federal department or agency;

b. Have not within a 3-year period preceding this proposal been convicted of or had a civil judgment rendered against them for commission of fraud or a criminal offense in connection with obtaining, attempting to obtain, or performing a public (Federal, State or local) transaction or contract under a public transaction; violation of Federal or State antitrust statutes or commission of embezzlement, theft, forgery, bribery, falsification or destruction of records, making false statements, or receiving stolen property;

c. Are not presently indicted for or otherwise criminally or civilly charged by a governmental entity (Federal, State or local) with commission of any of the offenses enumerated in paragraph 1b of this certification; and

Form 1273 -- Revised 3-95
08-07-95

FR-11

d. Have not within a 3-year period preceding this application/proposal had one or more public transactions (Federal, State or local) terminated for cause or default.

2. Where the prospective primary participant is unable to certify to any of the statements in this certification, such prospective participant shall attach an explanation to this proposal.

* * * * *

2. Instructions for Certification - Lower Tier Covered Transactions:

(Applicable to all subcontracts, purchase orders and other lower tier transactions of \$25,000 or more - 49 CFR 29)

a. By signing and submitting this proposal, the prospective lower tier is providing the certification set out below.

b. The certification in this clause is a material representation of fact upon which reliance was placed when this transaction was entered into. If it is later determined that the prospective lower tier participant knowingly rendered an erroneous certification, in addition to other remedies available to the Federal Government, the department or agency with which this transaction originated may pursue available remedies, including suspension and/or debarment.

c. The prospective lower tier participant shall provide immediate written notice to the person to which this proposal is submitted if at any time the prospective lower tier participant learns that its certification was erroneous by reason of changed circumstances.

d. The terms "covered transaction," "debarred," "suspended," "ineligible," "primary covered transaction," "participant," "person," "principal," "proposal," and "voluntarily excluded," as used in this clause, have the meanings set out in the Definitions and Coverage sections of rules implementing Executive Order 12549. You may contact the person to which this proposal is submitted for assistance in obtaining a copy of those regulations.

e. The prospective lower tier participant agrees by submitting this proposal that, should the proposed covered transaction be entered into, it shall not knowingly enter into any lower tier covered transaction with a person who is debarred, suspended, declared ineligible, or voluntarily excluded from participation in this covered transaction, unless authorized by the department or agency with which this transaction originated.

f. The prospective lower tier participant further agrees by submitting this proposal that it will include this clause titled "Certification Regarding Debarment, Suspension, Ineligibility and Voluntary Exclusion-Lower Tier Covered Transaction," without modification, in all lower tier covered transactions and in all solicitations for lower tier covered transactions.

g. A participant in a covered transaction may rely upon a certification of a prospective participant in a lower tier covered transaction that is not debarred, suspended, ineligible, or voluntarily excluded from the covered transaction, unless it knows that the certification is erroneous. A participant may decide the method and frequency by which it determines the el-

igibility of its principals. Each participant may, but is not required to, check the Nonprocurement List.

h. Nothing contained in the foregoing shall be construed to require establishment of a system of records in order to render in good faith the certification required by this clause. The knowledge and information of participant is not required to exceed that which is normally possessed by a prudent person in the ordinary course of business dealings.

i. Except for transactions authorized under paragraph e of these instructions, if a participant in a covered transaction knowingly enters into a lower tier covered transaction with a person who is suspended, debarred, ineligible, or voluntarily excluded from participation in this transaction, in addition to other remedies available to the Federal Government, the department or agency with which this transaction originated may pursue available remedies, including suspension and/or debarment.

* * * * *

**Certification Regarding Debarment,
Suspension, Ineligibility and Voluntary
Exclusion-Lower Tier Covered Transactions**

1. The prospective lower tier participant certifies, by submission of this proposal, that neither it nor its principals is presently debarred, suspended, proposed for debarment, declared ineligible, or voluntarily excluded from participation in this transaction by any Federal department or agency.

2. Where the prospective lower tier participant is unable to certify to any of the statements in this certification, such prospective participant shall attach an explanation to this proposal.

* * * * *

**XII. CERTIFICATION REGARDING USE OF
CONTRACT FUNDS FOR LOBBYING**

(Applicable to all Federal-aid construction contracts and to all related subcontracts which exceed \$100,000 - 49 CFR 20)

1. The prospective participant certifies, by signing and submitting this bid or proposal, to the best of his or her knowledge and belief, that:

a. No Federal appropriated funds have been paid or will be paid, by or on behalf of the undersigned, to any person for influencing or attempting to influence an officer or employee of any Federal agency, a Member of Congress, an officer or employee of Congress, or an employee of a Member of Congress in connection with the awarding of any Federal contract, the making of any Federal grant, the making of any Federal loan, the entering into of any cooperative agreement, and the extension, continuation, renewal, amendment, or modification of any Federal contract, grant, loan, or cooperative agreement.

b. If any funds other than Federal appropriated funds have been paid or will be paid to any person for influencing or attempting to influence an officer or employee of any Federal agency, a Member of Congress, an officer or employee of Congress, or an employee of a Member of Congress in connection with this Federal contract,

grant, loan, or cooperative agreement, the undersigned shall complete and submit Standard Form-LLL, "Disclosure Form to Report Lobbying," in accordance with its instructions.

2. This certification is a material representation of fact upon which reliance was placed when this transaction was made or entered into. Submission of this certification is a prerequisite for making or entering into this transaction imposed by 31 U.S.C. 1352. Any person who fails to file the required certification shall

be subject to a civil penalty of not less than \$10,000 and not more than \$100,000 for each such failure.

3. The prospective participant also agrees by submitting his or her bid or proposal that he or she shall require that the language of this certification be included in all lower tier subcontracts, which exceed \$100,000 and that all such recipients shall certify and disclose accordingly.

FEDERAL-AID FEMALE AND MINORITY GOALS

In accordance with Section II, "Nondiscrimination," of "Required Contract Provisions Federal-aid Construction Contracts" the following are the goals for female utilization:

Goal for Women
(applies nationwide).....(percent) 6.9

The following are goals for minority utilization:

CALIFORNIA ECONOMIC AREA

	Goal (Percent)
174 Redding, CA:	
Non-SMSA Counties	6.8
CA Lassen; CA Modoc;	
CA Plumas; CA Shasta;	
CA Siskiyou; CA Tehama.	
175 Eureka, CA:	
Non-SMSA Counties	6.6
CA Del Norte; CA Humboldt;	
CA Trinity.	
176 San Francisco-Oakland-San Jose, CA:	
SMSA Counties:	
7120 Salinas-Seaside-	
Monterey, CA.....	28.9
CA Monterey.	
7360 San Francisco-Oakland, CA.....	25.6
CA Alameda; CA Contra Costa;	
CA Marin; CA San Francisco;	
CA San Mateo.	
7400 San Jose, CA	19.6
CA Santa Clara.	
7485 Santa Cruz, CA	14.9
CA Santa Cruz.	
7500 Santa Rosa, CA	9.1
CA Sonoma.	
8720 Vallejo-Fairfield- Napa, CA	17.1
CA Napa; CA Solano	
Non-SMSA Counties	23.2
CA Lake; CA Mendocino;	
CA San Benito.	

177 Sacramento, CA:	
SMSA Counties:	
6920 Sacramento, CA.....	16.1
CA Placer; CA Sacramento;	
CA Yolo.	
Non-SMSA Counties.....	14.3
CA Butte; CA Colusa;	
CA El Dorado; CA Glenn;	
CA Nevada; CA Sierra;	
CA Sutter; CA Yuba.	

178 Stockton-Modesto, CA:	
SMSA Counties:	
5170 Modesto, CA	12.3
CA Stanislaus.	
8120 Stockton, CA	24.3
CA San Joaquin.	
Non-SMSA Counties.....	19.8
CA Alpine; CA Amador;	
CA Calaveras; CA Mariposa;	
CA Merced; CA Tuolumne.	

179 Fresno-Bakersfield, CA:	
SMSA Counties:	
0680 Bakersfield, CA	19.1
CA Kern.	
2840 Fresno, CA.....	26.1
CA Fresno.	
Non-SMSA Counties.....	23.6
CA Kings; CA Madera;	
CA Tulare.	

180 Los Angeles, CA:	
SMSA Counties:	
0360 Anaheim-Santa Ana-Garden	
Grove, CA	11.9
CA Orange.	
4480 Los Angeles-Long	
Beach, CA	28.3
CA Los Angeles.	
6000 Oxnard-Simi Valley-	
Ventura, CA	21.5
CA Ventura.	

Form 1273 — Revised 3-95
08-07-95

6780 Riverside-San Bernardino- Ontario, CA	19.0
CA Riverside; CA San Bernardino.	
7480 Santa Barbara-Santa Maria- Lompoc, CA	19.7
CA Santa Barbara.	
Non-SMSA Counties	24.6
CA Inyo; CA Mono; CA San Luis Obispo.	
181 San Diego, CA:	
SMSA Counties	
7320 San Diego, CA.....	16.9
CA San Diego.	
Non-SMSA Counties	18.2
CA Imperial.	

In addition to the reporting requirements set forth elsewhere in this contract the Contractor and subcontractors holding subcontracts, not including material suppliers, of \$10,000 or more, shall submit for every month of July during which work is performed, employment data as contained under Form FHWA PR-1391 (Appendix C to 23 CFR, Part 230), and in accordance with the instructions included thereon.

Form 1273 — Revised 3-95
08-07-95

STATE OF CALIFORNIA - DEPARTMENT OF TRANSPORTATION
FINAL REPORT-UTILIZATION OF DISADVANTAGED BUSINESS ENTERPRISES (DBE), FIRST-TIER SUBCONTRACTORS

ADA Notice

For individuals with sensory disabilities, this document is available in alternate formats. For information call (916) 654-6410 or TDD (916) 654-3880 or write Records and Forms Management, 1120 N Street, MS-89, Sacramento, CA 95814

CEM-2402F (REV 02/2008)

CONTRACT NUMBER	COUNTY	ROUTE	POST MILES	FEDERAL AID PROJECT NO.	ADMINISTERING AGENCY	CONTRACT COMPLETION DATE					
PRIME CONTRACTOR			BUSINESS ADDRESS		ESTIMATED CONTRACT AMOUNT						
ITEM NO.	DESCRIPTION OF WORK PERFORMED AND MATERIAL PROVIDED	COMPANY NAME AND BUSINESS ADDRESS	DBE CERT NUMBER	CONTRACT PAYMENTS						DATE WORK COMPLETE	DATE OF FINAL PAYMENT
				NON-DBE	DBE	BA UDBE	APA UDBE	NA UDBE	W UDBE		
ORIGINAL COMMITMENT			TOTAL	\$	\$	\$	\$	\$	\$		
UDBE											

List all First-Tier Subcontractors, Disadvantaged Business Enterprises (DBEs) and underutilized DBEs (UDBEs) regardless of tier, whether or not the firms were originally listed for goal credit. If actual UDBE utilization for item of work was different than that approved at time of award, provide comments on back of form. List actual amount paid to each entity.

I CERTIFY THAT THE ABOVE INFORMATION IS COMPLETE AND CORRECT

CONTRACTOR REPRESENTATIVE'S SIGNATURE _____ BUSINESS PHONE NUMBER _____ DATE _____

RESIDENT ENGINEER'S SIGNATURE _____ TO THE BEST OF MY INFORMATION AND BELIEF, THE ABOVE INFORMATION IS COMPLETE AND CORRECT BUSINESS PHONE NUMBER _____ DATE _____

Copy Distribution-Caltrans contracts: Original - District Construction Copy- Business Enterprise Program Copy- Contractor Copy Resident Engineer
 Copy Distribution-Local Agency contracts: Original - District Local Assistance Engineer Copy- District Local Assistance Engineer Copy- Local Agency file

Final Report-Utilization of Disadvantaged Business Enterprises (DBE), First-Tier Subcontractors

FINAL REPORT – UTILIZATION OF DISADVANTAGED BUSINESS ENTERPRISES (DBE), FIRST-TIER SUBCONTRACTORS
CEM 2402(F) (Rev. 02/2008)

The form requires specific information regarding the construction project: Contract Number, County, Route, Post Miles, Federal-aid Project No., the Administering Agency, the Contract Completion Date and the Estimated Contract Amount. It requires the prime contractor name and business address. The focus of the form is to describe who did what by contract item number and descriptions, asking for specific dollar values of item work completed broken down by subcontractors who performed the work both DBE and non-DBE work forces. DBE prime contractors are required to show the date of work performed by their own forces along with the corresponding dollar value of work.

The form has a column to enter the Contract Item No. (or Item No's) and description of work performed or materials provided, as well as a column for the subcontractor name and business address. For those firms who are DBE, there is a column to enter their DBE Certification Number. The DBE should provide their certification number to the contractor and notify the contractor in writing with the date of the decertification if their status should change during the course of the project.

The form has six columns for the dollar value to be entered for the item work performed by the subcontractor.

The Non-DBE column is used to enter the dollar value of work performed for firms who are not certified DBE.

The decision of which column to be used for entering the DBE dollar value is based on what program(s) status the firm is certified. This program status is determined by the California Unified Certification Program by ethnicity, gender, ownership, and control issues at time of certification. To confirm the certification status and program status, access the Department of Transportation Civil Rights web site at: <http://www.dot.ca.gov/hq/bep> or by calling (916) 324-1700 or the toll free number at (888) 810-6346.

Based on this DBE Program status, the following table depicts which column to be used:

DBE Program Status	Column to be used
If program status shows DBE only with no other programs listed	DBE
If program status shows DBE, Black American	BA UDBE
If program status shows DBE, Asian-Pacific Islander	APA UDBE
If program status shows DBE, Native American	NA UDBE
If program status shows DBE, Woman	W UDBE

If a contractor performing work as a DBE on the project becomes decertified and still performs work after their decertification date, enter the total dollar value performed by this contractor under the appropriate DBE identification column.

If a contractor performing work as a non-DBE on the project becomes certified as a DBE, enter the dollar value of all work performed after certification as a DBE under the appropriate identification column.

Enter the total of each of the six columns in Form CEM-2402(F).

Any changes to DBE certification must also be submitted on Form-CEM 2403(F).

Enter the Date Work Completed as well as the Date of Final Payment (the date when the prime contractor made the "final payment" to the subcontractor for the portion of work listed as being completed).

The contractor and the resident engineer sign and date the form indicating that the information provided is complete and correct.

STATE OF CALIFORNIA • DEPARTMENT OF TRANSPORTATION
**DISADVANTAGED BUSINESS ENTERPRISES (DBE)
 CERTIFICATION STATUS CHANGE**
 CEM-2403(F) (REV 4/2005)

ADA Notice

For individuals with sensory disabilities, this document is available in alternate formats. For information call (916) 654-6410 or TDD (916) 654-3880 or write Records and Forms Management, 1120 N Street, MS-99, Sacramento, CA 95814.

CONTRACT NUMBER COUNTY ROUTE POST MILES BUSINESS ADDRESS ADMINISTERING AGENCY CONTRACT COMPLETION DATE
 PRIME CONTRACTOR BUSINESS ADDRESS ESTIMATED CONTRACT AMOUNT \$

The Contractor: List all DBEs with change in certification status (certified/decertified) while in your employ, whether or not firms were originally listed for goal credit. Attach DBE certification/decertification letter in accordance with the Special Provisions.

CONTRACT ITEM NO.	SUBCONTRACTOR NAME AND BUSINESS ADDRESS	BUSINESS PHONE	CERTIFICATION NUMBER	AMOUNT PAID WHILE CERTIFIED	CERTIFICATION/DECERTIFICATION DATE <small>Letter attached</small>

COMMENTS:

I CERTIFY THAT THE ABOVE INFORMATION IS COMPLETE AND CORRECT

CONTRACTOR REPRESENTATIVE'S SIGNATURE TITLE BUSINESS PHONE NUMBER DATE

RESIDENT ENGINEER'S SIGNATURE BUSINESS PHONE NUMBER DATE

TO THE BEST OF MY KNOWLEDGE, THE ABOVE INFORMATION IS COMPLETE AND CORRECT

COPY DISTRIBUTION: Original - Civil Rights Copy - Contractor Copy - District Construction Copy - Resident Engineer

DISADVANTAGED BUSINESS ENTERPRISES (DBE)

CERTIFICATION STATUS CHANGE

CEM-2403(F) (REV 4/2005)

The top of the form requires specific information regarding the construction project: Contract Number, County, Route, Post Miles, the Administering Agency (Caltrans), the Contract Completion Date and the Estimated Contract Amount. It requires the prime contractor name and business address. The focus of the form is to substantiate and verify the actual DBE dollar amount paid to contractors on federally funded projects that had a change in certification status during the course of the completion of the contract. The two situations that are being address by CEM 2403(F) are if a firm certified as a DBE and doing construction work on the contract during the course of the project becomes decertified, and if a non-DBE firm doing work on the contract during the course of the project becomes certified as a DBE.

The form has a column to enter the Contract Item No. (or Item No's), as well as a column for the Subcontractor name and Business Address, Business Phone and contractor's Certification Number.

The column entitled Amount Paid While Certified will be used to enter the actual dollar value of the work performed by those contractors who meet the conditions as outlined above during the time period they are certified as a DBE. This column on the CEM-2403(F) should only reflect the dollar value of work performed while the firm was certified as a DBE.

The column called Certification/Decertification Date (Letter attached) will reflect either the date of the Decertification Letter sent out by the Civil Rights or the date of the Certification Certificate mailed out by the Civil Rights. There is a box to check that support documentation is attached to the CEM-2403(F) form.

There is a comments section for any additional information that may need to be provided regarding any of the above transactions.

The CEM-2403(F) has an area at the bottom where the contractor and the resident engineer sign and date that the information provided is complete and correct.

SECTION 7. (BLANK)

SECTION 8 MATERIALS

SECTION 8-1. MISCELLANEOUS

8-1.01 **BUY AMERICA REQUIREMENTS:**

Attention is directed to the "Buy America" requirements of the Surface Transportation Assistance Act of 1982 (Section 165) and the Intermodal Surface Transportation Efficiency Act of 1991 (ISTEA) Sections 1041(a) and 1048(a), and the regulations adopted pursuant thereto. In conformance with the law and regulations, all manufacturing processes for steel and iron materials furnished for incorporation into the work on this project shall occur in the United States; with the exception that pig iron and processed, pelletized and reduced iron ore manufactured outside of the United States may be used in the domestic manufacturing process for such steel and iron materials. The application of coatings, such as epoxy coating, galvanizing, painting, and other coating that protects or enhances the value of steel or iron materials shall be considered a manufacturing process subject to the "Buy America" requirements.

A Certificate of Compliance, conforming to the provisions in Section 6-1.07, "Certificates of Compliance" of the Standard Specifications, shall be furnished for steel and iron materials. The certificates, in addition to certifying that the materials comply with the specifications, shall specifically certify that all manufacturing processes for the materials occurred in the United States, except for the above exceptions.

The requirements imposed by the law and regulations do not prevent a minimal use of foreign steel and iron materials if the total combined cost of the materials used does not exceed one-tenth of one percent (0.1 percent) of the total contract cost or \$2,500, whichever is greater. The Contractor shall furnish the Engineer acceptable documentation of the quantity and value of the foreign steel and iron prior to incorporating the materials into the work.

8-1.02 **SLAG AGGREGATE:**

Steel slag shall not be used on this project. Iron blast furnace slag will be allowed.

8-1.03**YEAR 2000 COMPLIANCE:**

This contract is subject to Year 2000 Compliance for automated devices in the State of California.

Year 2000 compliance for automated devices in the State of California is achieved when embedded functions have or create no logical or mathematical inconsistencies when dealing with dates prior to and beyond 1999. The year 2000 is recognized and processed as a leap year. The product shall operate accurately in the manner in which the product was intended for date operation without requiring manual intervention.

The Contractor shall provide the Engineer a Certificate of Compliance from the manufacturer in conformance with the provisions in Section 6-1.07, "Certificates of Compliance" of the Standard Specifications for all automated devices furnished for the project.

8-1.04

TESTING:

Whenever a reference is made in the specifications to any of the California Test numbers specified below the corresponding ASTM Designation or AASHTO Designation test numbers may be used to determine the quality of materials

California Test	ASTM Designation	AASHTO Designation
216	D 1557	T 180
231	D 2922	T 238
203	D 422	T 88
204	D 4318	T 89 (a)
		T 90 (b)
504	C 231	T 152
518	C 138	T 121
521	C 39	T 22
523	C 293 (c)	T 177 (c)
	C 78 (d)	T 97 (d)
533	C 360	--
211	C 131 (e)	T 96 (f)
	C 535 (g)	--

Notes:

- (a) Determining the Liquid Limit of Soils.
- (b) Determining the Plastic Limit and Plasticity Index of Soils.
- (c) Flex Strength of Concrete
(Using Simple Beam with Center Point Loading).
- (d) Flexural Strength of Concrete
(Using the Simple Beam with Third Point Loading).
- (e) Resistance to Degradation of Small-Size Coarse Aggregate by Abrasion and Impact on the Los Angeles Machine.
- (f) Resistance to Degradation of Small- Size Coarse Aggregate by Use of the Los Angeles Machine.
- (g) Resistance to Degradation of Large-Size Coarse Aggregate by Abrasion and Impact in the Los Angeles Machine.

SECTION 9 (BLANK)

SECTION 10

**EL SOBRANTE ROAD
SAFETY PROJECT
SHOULDER WIDENING & STRIPING
FROM LA SIERRA AVENUE TO CAJALCO ROAD**

**PROJECT NO. B8-0620
FEDERAL AID NO. HRRRL – 5956 (182)**

SPECIAL PROVISIONS

10-1.01 DESCRIPTION:

In general, this project is a federally funded safety project to widen the paved shoulders on two segments of El Sobrante Road and provide enhanced striping and pavement markers from La Sierra Avenue to Cajalco Road. The Work includes widening the pavement on two segments of El Sobrante Road by 4' and provides a 4' graded shoulder on each side. Widening Segment 1 is from McAllister Street to one mile east, and Widening Segment 3 is from Mockingbird Canyon Road to Cajalco Road. This project will provide new pavement markings, restripe lane lines and replace missing raised pavement markers from McAllister Street to Cajalco Road. New raised pavement markers will be installed from La Sierra Avenue to McAllister Street.

Specifically, the work includes sawcut, pavement removal, excavation, Class 2 aggregate base, Hot Mix Asphalt, shoulder grading, asphalt dike, overside drains, rumble strip, raised pavement markers, striping and pavement markings. Other work as may be required.

10-1.02 SPECIFICATIONS:

This project shall conform to the requirements of the May 2006 edition of the Standard Specifications and Standard Plans as issued by the State of California Department of Transportation.

Requirements on the construction plans for Portland Cement Concrete are modified to the PCC Class designations, as described in Section 90-1.01 of the 2006 Standard Specifications, as follows:

Class "A" shall mean Class "2"
Class "B" shall mean Class "3"
Class "C" shall mean Class "4"
Class "D" shall mean Class "1"

10-1.03 LIQUIDATED DAMAGES:

The Contractor shall diligently prosecute the work to completion before the expiration of **30** working days from the date stated in the "Notice to Proceed". The Contractor shall pay to the County of Riverside the sum of **\$5,000.00** per day, for each and every calendar day's delay in finishing the work in excess of the number of working days prescribed above.

10-1.04 HOURS OF WORK

Refer to Section 2; subsection "Hours of Work" of these Specifications and replace with the following working hours:

All work shall be performed between the hours of 7:00 A.M. and 6:00 P.M., Monday through Friday, except legal holidays, or as approved by the Engineer. Exceptions and specific work schedules shall be submitted to the Engineer for consideration.

10-1.05 DISPOSAL OF EXCESS EXCAVATION OR MATERIALS:

Excess earth excavation, pavement grindings and other excess materials resulting from construction operations shall be disposed of by the Contractor outside of the highway right of way, as provided in Section 7-1.13 of the Standard Specifications.

The second paragraph of Section 7-1.13 of the Standard Specifications is modified to read as follows:

When any material is to be disposed of outside the highway right of way, and the County of Riverside has not made arrangements for the disposal of such material, the Contractor shall first obtain written authorization from the property owner on whose property the disposal is to be made and he shall file with the Engineer said authorization or a certified copy thereof together with a written release from the property owner absolving the County of Riverside from any and all responsibility in connection with the disposal of material on said property. If the disposal of materials is to be made at an established disposal facility that is available for public use, the Contractor shall retain all authorizations and receipts from said disposal facility and shall provide copies to the Engineer upon request.

10-1.06 PROJECT APPEARANCE:

The Contractor shall maintain a neat appearance to the work.

In any area visible to the public, the following shall apply:

When practicable, broken concrete and debris developed during clearing and grubbing shall be disposed of concurrently with its removal. If stockpiling is necessary, the material shall be removed or disposed of weekly.

The Contractor shall furnish trash bins for all debris from structure construction. All debris shall be placed in trash bins daily. Forms of the falsework that are to be reused shall be stacked neatly concurrently with their removal.

Full compensation for conforming to the provisions in this section, not otherwise provided for, shall be considered as included in the prices paid for the various contract items of work involved and no additional compensation will be allowed therefor.

10-1.07 RECORD DRAWINGS:

The Contractor shall keep one clean set of bond originals to note any changes which take place during construction. These changes to the original plans and/or specifications shall be noted at the appropriate locations with the appropriate changes indicated in red pencil or ink. The Contractor shall note in large letters "RECORD DRAWINGS" on the Title Sheet of the plans. The job will not be finalized by the Engineer until these record drawings have been completed to the satisfaction of the Engineer. The changes shall be noted on the plans as the changes occur. The record drawings shall be submitted to the Resident Engineer, and become the property of the County at conclusion of the project.

Full compensation for maintaining and compiling the record drawings shall be considered to be included in other items of work and no additional compensation will be allowed therefor.

10-1.08 ITEMS OF WORK:

10-1.09 PARTIAL PAYMENTS:

Attention is directed to Sections 9 1.06, "Partial Payments," and 9 1.07, "Payment After Acceptance," of the Standard Specifications and these special provisions.

For the purpose of making partial payments pursuant to Section 9- 1.06, "Partial Payments," of the Standard Specifications, the amount set forth for the contract items of work hereinafter listed shall be deemed to be the maximum value of the contract item of work which will be recognized for progress payment purposes:

A. Clearing and Grubbing	\$ 6,900
B. Develop Water Supply	\$ 2,500

After acceptance of the contract pursuant to the provisions in Section 7-1.17, "Acceptance of Contract" of the Standard Specifications, the amount, if any, payable for a contract item of work in excess of the maximum value for progress payment purposes hereinabove listed for the item, will be included for payment in the first estimate made after acceptance of the contract.

ORDER OF WORK:

Order of work shall conform to the provisions in section 5-1.05, "Order of Work" of the Standard Specifications and these Special Provisions.

Attention is directed to "Public Convenience" of these Special Provisions regarding access to the homes and business with driveways on El Sobrante Road. The Contractor shall coordinate with these occupants and business to make accommodations to provide continual access available.

Attention is directed to "Public Convenience" of these Special Provisions regarding the Public Awareness Program and responding to communications with the public. The Contractor shall coordinate with the Public Affairs Officer retained by the County on project signage, responding to comments and complaints from the public and other public awareness requests as needed.

Attention is directed to "Clearing and Grubbing" of these Special Provisions regarding private improvements within the project area. There are several homes on El Sobrante Road with private improvements within the project area. The Contractor shall work directly with the property owners to minimize the disturbance to the private improvements including driveways, fencing walls, landscaping and decorative features.

Attention is directed to "Closure Schedule" of these Special Provisions regarding phasing of closures. All excavation and paving work is to be performed on the northerly side of El Sobrante Road in the first phase. At no time shall any excavation and paving be allowed on the northerly side and the southerly side of El Sobrante Road concurrently. Contractor shall coordinate the excavation and paving on the southerly side of El Sobrante Road with the Gas Company and the 8" steel high pressure gas main relocations.

Attention is directed to "Cooperation" of these Special Provisions regarding excavation and paving adjacent to the existing 8" steel high pressure gas main on the southerly side of El Sobrante Road. Contractor shall construct the improvements as shown unless it is determined by the County that the relocation of the 8" steel high pressure gas main takes priority. Contractor shall not be entitled to compensation for right-of-way delays due to the Gas Company's work being in progress through the end of August, 2011.

Attention is directed to "Public Safety" of these Special Provisions regarding access for emergency vehicles on El Sobrante Road. The Contractor shall provide continual 12' drivable access for emergency vehicles.

Attention is directed to "Liquidated Damages" of these Special Provisions regarding specific duration times for completion of work. El Sobrante Road is a vital commuter route and there are significant liquidated damages for delays.

10-1.11

TRAFFIC CONTROL SYSTEM/ PUBLIC CONVENIENCE/ PUBLIC SAFETY:

Contractor shall prepare construction staging, detour and traffic control plans for review and approval by the Transportation Department.

Proposed plans shall be submitted by the Contractor for review and approval by the Transportation Department at least two weeks prior to the start of construction. The construction staging, detour plans and traffic control plans shall be prepared, signed and stamped by a Civil Engineer or Traffic Engineer who is registered as such in the State of California, unless otherwise specifically allowed by the Engineer. The Contractor shall revise and implement the plans as directed by the Construction Engineer. Construction shall not begin until the Engineer provides Contractor with County approval of the plans.

Construction staging, detour and traffic control plans shall be in accordance with the appropriate standards and specifications for construction staging, detour roads, traffic control, including the State of California Highway Design Manual, the manual on Uniform Traffic Control Devices 2006 Edition, the corresponding California Supplement, and subsequent modifications as adopted by the State of California Department of Transportation, Standard Plans and Standard Specifications, and the Work Area Traffic Control Handbook (WATCH), as published by Building News, Inc. Any requests for deviation from the established design standards or specifications are to be submitted to the Construction Engineer for review and approval prior to submission of the required plans.

With regard to the preparation and implementation of the plans, attention is especially directed to Sections 7-1.06, 7-1.08, 7-1.09, 7-1.11, 7-1.12 and Section 12 of the State of California Standard Specifications. Section 12-2.02 of the Standard Specifications is deleted.

Maintaining traffic shall conform to the provisions in 7-1.02 "Load Limitations", 7-1.06 "Safety and Health Provisions", 7-1.08 "Public Convenience", 7-1.09 "Public Safety", and 12-3.04 "Portable Delineators" of the Standard Specifications, the Manual on Uniform Traffic Control Devices 2006 Edition, the corresponding California Supplement, and subsequent modifications as adopted by the State of California Department of Transportation, the Section of these contract documents entitled "Insurance - Hold Harmless", and these Special Provisions.

All existing traffic control signs and street name signs shall be maintained in visible locations as directed by the Engineer.

Portable changeable message signs shall be furnished, placed, operated and maintained at those locations shown on the approved Traffic Control Plans or where designated by the Engineer in conformance with the provisions in Section 12, "Construction Area Traffic Control Devices" of the Standard Specifications and these Special Provisions.

All warning lights, signs, flares, barricades and other facilities for the sole convenience and direction of public traffic shall be furnished and maintained by the Contractor. All traffic control devices shall conform to and be placed in accordance with the Manual on

Uniform Traffic Control Devices 2006 Edition, the corresponding California Supplement, and subsequent modifications as adopted by the State of California Department of Transportation.

All construction signs shall be either covered or removed when not required by the nature of the work or if no present hazard to the motorist exists.

The Contractor shall notify the appropriate regional notification center for operators of subsurface installations at least 2 working days, but not more than 14 calendar days, prior to commencing excavation for construction area sign posts. The regional notification centers include, but not limited to, the following:

Notification Center	Telephone Number
Underground Service Alert- Southern California (USA)	1-800-422-4133 1-800-227-2600 or 811

Excavations required to install construction area signs shall be performed by hand methods without the use of power equipment, except that power equipment may be used if it is determined there are no utility facilities in the area of the proposed post holes.

No payment for extra work will be allowed for work performed as specified in Section 12-2.02 (Flagging Costs) of the Standard Specifications. Flagging costs will be borne entirely by the Contractor.

Dust control shall conform to the provision of Section 10 of the Standard Specifications except that no extra work will be allowed when the Engineer orders the application of water for the purpose of controlling dust caused by public traffic as provided for in the last paragraph of Section 10.

The Contractor shall be responsible to distribute an information letter pertaining to the planned work to all affected residences and businesses, at least one week prior to commencing work adjacent to those residences and businesses. It shall be the responsibility of the Contractor to coordinate with the Public Affairs Officer to obtain, print sufficient copies, and distribute the letter. The Transportation Department logo shall be included on the letter. A computer file of the logo may be obtained from the Engineer in .WPG, .DXF, .DGN or .DWG format. The letter shall be similar to the sample provided by the Engineer, and shall include a project description, the scope of work, the anticipated construction schedule, and other information as appropriate.

The Contractor shall post temporary no parking signs on affected streets 24 hours prior to work on those streets. The temporary no parking signs shall state the anticipated dates and hours of work on those streets.

Payment - Full compensation, except as otherwise provided herein, for conforming to the requirements of this article, including furnishing, installing and maintaining all traffic control devices shown on the construction staging, detour and traffic control

plans, shall be paid for on a lump sum basis, and no additional compensation will be allowed therefor.

10-1.12 MAINTAINING TRAFFIC:

Maintaining traffic shall conform to the provisions in Section 7-1.08, "Public Convenience", Section 7-1.09, "Public Safety" and Section 12, "Construction Area Traffic Control Devices" of the Standard Specifications and "Public Safety" of these Special Provisions.

Daily working hours shall be between the hours of 7:00 a.m. and 6:00 p.m., Monday through Friday, except legal holidays, as approved by the Engineer. Exceptions and specific work schedules shall be submitted to the Engineer for consideration.

Closure is defined as the closure of a traffic lane or lanes, including shoulder, ramp or connector lanes, within a single traffic control system.

Closure shall conform to the provisions in "Traffic Control System" of these Special Provisions.

Local authorities shall be notified at least five (5) business days before work begins. The Contractor shall cooperate with local authorities to handle traffic through the work area and shall make arrangements to keep the work area clear of parked vehicles.

Personal vehicles of the Contractor's employees shall not be parked on the traveled way or shoulders including sections closed to public traffic.

When work vehicles or equipment are parked on the shoulder within six (6) feet of a traffic lane, the shoulder area shall be closed.

When work vehicles or equipment are parked on the shoulder within six (6) feet of a traffic lane, the shoulder area shall be closed with fluorescent orange traffic cones or portable delineators placed on a taper in advance of the parked vehicles or equipment and along the edge of the pavement at 25-foot intervals to a point not less than 25 feet past the last vehicle or piece of equipment. A minimum of 9 traffic cones or portable delineators shall be used for the taper. A W20-1 (ROAD WORK AHEAD) or W21-5b (RIGHT/LEFT SHOULDER CLOSED AHEAD) or C24 (CA) (SHOULDER WORK AHEAD) sign shall be mounted on a crashworthy portable sign support with flags. The sign shall be placed where designated by the Engineer. The sign shall be a minimum of 48" x 48" in size. The Contractor shall immediately restore to the original position and location a traffic cone or delineator that is displaced or overturned, during the progress of work.

If minor deviations from the lane requirement chart are required, a written request shall be submitted to the Engineer at least 15 days before the proposed date of the closure. The Engineer may approve the deviations if there is no significant increase in the cost to the County and if the work can be expedited and better serve the public traffic.

Designated legal holidays are January 1st, the third Monday in February, the last Monday in May, July 4th, the first Monday in September, November 11th, Thanksgiving Day, and December 25th. When a designated legal holiday falls on a Sunday, the following Monday shall be a designated legal holiday. When November 11th falls on a Saturday, the preceding Friday shall be a designated legal holiday.

Full compensation for furnishing, erecting, maintaining, removing and disposing of the C43 (CA), W20-1, W21-5b and C24 (CA) signs shall be considered as included in the contract lump sum price paid for Traffic Control System and no additional compensation will be allowed therefor.

10-1.13 PORTABLE CHANGEABLE MESSAGE SIGNS:

GENERAL

Summary

Work includes furnishing, placing, operating, maintaining, and removing portable changeable message signs.

Comply with Section 12-3.12 "Portable Changeable Message Signs" of the Standard Specifications.

Definition

Useable Shoulder Area: Paved or unpaved contiguous surface adjacent to the traveled way with:

1. Sufficient weight bearing capacity to support portable changeable message sign.
2. Slope not greater than 6:1 (horizontal:vertical).

Submittals

Upon request, submit a Certificate of Compliance for each portable changeable message sign under Section 6-1.07, "Certificates of Compliance" of the Standard Specifications.

Quality Control and Assurance

Comply with the manufacturer's operating instructions for portable changeable message sign.

Approaching drivers must be able to read the entire message for all phases at least twice at the posted speed limit before passing portable changeable message sign. The Contractor may use more than 1 portable changeable message sign to meet this requirement.

Only display the message shown on the plans or ordered by the Engineer or specified in these Special Provisions.

MATERIALS

Portable changeable message sign must have 24-hour timer control or remote control capability.

The text of the message displayed on portable changeable message sign must not scroll, or travel horizontally or vertically across the face of the message panel.

CONSTRUCTION

Continuously repeat the entire message in no more than 2 phases of at least 3 seconds per phase.

If useable shoulder area is at least 15 feet wide, the displayed message on portable changeable message sign must be minimum 18-inch character height. If useable shoulder area is less than 15 feet wide, you may use a smaller message panel with minimum 12-inch character height to prevent encroachment in the traveled way.

The Contractor shall provide the cell phone number to the Engineer and must be available by cell phone for operations that require portable changeable message signs or to modify the displayed message.

Before closing the lane, the Contractor shall start displaying the message on portable changeable message sign as directed by the Engineer.

Place portable changeable message sign in advance of the first warning sign for:

1. Each stationary lane closure.
2. Each off-ramp closure.
3. Each connector closure.
4. Each shoulder closure.
5. Each speed reduction zone.

Place portable changeable message sign as far from the traveled way as practicable where it is legible to traffic and does not encroach on the traveled way. Place portable changeable sign before or at the crest of vertical roadway curvature where it is visible to approaching traffic. Avoid placing portable changeable message sign within or immediately after horizontal roadway curvature. Where possible, place portable changeable message sign behind guardrail or temporary railing (Type K).

Except where placed behind guardrail or temporary railing (Type K) use traffic control for shoulder closure to delineate portable changeable message sign.

Remove portable changeable message sign when not in use.

MEASUREMENT AND PAYMENT

Full compensation for portable changeable message signs, including furnishing, placing, operating, modifying messages, maintaining, transporting from location to location,

removing, and repairing or replacing defective or damaged portable changeable message signs is included in the contract price paid under Traffic Control and no separate payment will be made therefor.

Portable changeable message signs ordered by the Engineer in excess of the number shown on the plans or specified in these Special Provisions will be paid for as extra work under Section 4-1.03D, "Extra Work" of the Standard Specifications.

10-1.14 COOPERATION:

Attention is directed to Section 7-1.14, "Cooperation" of the Standard Specifications and these Special Provisions.

The Contractor is hereby advised to cooperate with utility companies (Gas Company, WMWD and/or others) for adjusting water valves, manholes and other facilities to grade.

In the event that the gas company's work does overlap our contract work a bit, the Contractor shall construct the improvements as shown unless it is determined by the County that the relocation of the 8" steel high pressure gas main takes priority.

Should construction be under way by other forces or by other Contractors within or adjacent to those limits, the Contractor shall cooperate with all the other Contractors or other forces to the end that any delay or hindrance to their work will be avoided. The right is reserved to perform other or additional work at or near the site (including material sources) at any time, by the use of other forces.

10-1.15 CONSTRUCTION PROJECT FUNDING IDENTIFICATION SIGNS:

County furnished Construction Project Funding Identification Signs (4' X 8') shall be installed at a location to be determined by the Engineer, within or near the project limits, in accordance with the relevant requirements of Section 56-2 of the Standard Specifications and the appropriate details of Standard Plans RS1 through RS4 for two post installation of signs, and as directed by the Engineer.

The Contractor shall be responsible to:

1. Obtain and load the Construction Project Funding Identification Signs at the McKenzie Highway Operations Center, 2950 Washington Street, Riverside, California 92504, and telephone (951) 955-6899.
2. Transport the signs to the job site and off-load.
3. Install the signs using Contractor furnished posts, hardware and other required materials.

4. At the completion of the project, when directed by the Engineer, remove signs from installation location, remove Contractor owned posts and hardware from sign panel, load the signs, and deliver the signs to the address listed above.
5. Off-load the signs to the location directed by the Engineer or other County Representative.

Full compensation for the installation of Construction Project Funding Identification Signs, including transportation, furnishing all labor, materials, tools, equipment, and incidentals and for doing all the required work, including all necessary excavation and backfill, shall be considered as included in the various items of work, and no additional compensation will be allowed therefor.

10-1.16 OBSTRUCTIONS:

Attention is directed to Sections 8-1.10, "Utility and Non-Highway Facilities", and 15, "Existing Highway Facilities" of the Standard Specifications and these Special Provisions.

Existing utility and privately owned facilities shall be protected in accordance with Section 7-1.11, "Preservation of Property" and these Special Provisions. The Contractor is also responsible to protect those facilities that are to be relocated by others prior to or during construction, and shall protect those facilities in both their existing and their ultimate locations. The Contractor shall cooperate with owners and their Contractors of utility and privately owned facilities, for the relocation of said facilities, in accordance with Section 7-1.14, "Cooperation" of the Standard Specifications.

All water valves and covers, gas valves and covers, sewer manholes, survey monuments, survey markers and any other utility appurtenances shall be protected in place.

The Contractor's attention is directed to the existence of certain underground facilities that may require special precautions be taken by the Contractor to protect the health, safety and welfare of workmen and the public. Facilities requiring special precautions include, but are not limited to: conductors of petroleum products, oxygen, chlorine, and toxic or flammable gases; natural gas in pipe lines greater than 6 inches in diameter or pipe lines operating at pressures greater than 60 psi (gage); underground electric supply system conductors or cables either directly buried or in duct or conduit which do not have concentric neutral conductors or other effectively grounded metal shields or sheaths; and underground electrical conductors with potential to ground of more than 300 volts. The Contractor shall notify the Engineer at least twenty-four hours prior to performing any work in the vicinity of such facilities.

Attention is directed to the requirements of Government Code Sections 4216-4216.9 pertaining to existing utility facilities.

The Contractor shall assume that every house, building and lot within the project limits has utility service pipes and conductors (laterals), and that utility main and trunk

facilities exist within the project limits. The Contractor shall determine if it is warranted to determine the exact location of these utility service laterals and existing main lines, unless directed by the Engineer to pot-hole at specific locations, or as otherwise required herein. The Contractor will not be directly reimbursed for determining the exact location of the utility main lines or services laterals but shall include any compensation for this work in the contract price paid for the various items of work. Any damage to existing main lines or service laterals for which pot-holing was not performed shall be considered damage due to not using reasonable care and the damage shall be repaired at the Contractor's expense.

The Contractor shall conduct his operations with the assumption that underground utility facilities exist within the project limits. The Contractor shall exercise caution and best construction practices for safety and for protection of underground facilities. The approximate locations of underground utility facilities, as shown on the plans, are based on information provided by the respective owners, listed below. The Contractor shall also utilize the markings of the regional notification center (Underground Service Alert), and above-ground utility appurtenances to determine the existence and approximate location of underground utilities.

No excavation shall be made within 4 feet of any underground utilities, as shown on the plans and/or marked by Underground Service Alert, unless and until such utilities have been positively located as to horizontal and vertical position. This requirement applies to all underground electric, natural gas, toxic or flammable gas, chlorine, oxygen or petroleum facilities.

Forty-eight hours prior to beginning construction, the Contractor shall notify the following agencies:

Underground Service Alert	800-227-2600
Southern California Edison Company	714-796-9932
Southern California Gas Company	909-335-7561
AT & T	714-963-7964
Kinder Morgan Energy Partners, L.P.	714-560-4600
Verizon Communication	951-925-5319
MCI Network Services, Inc.	972-729-6016
Santa Ana River Water Company	951-685-6503
Western Municipal Water District	951-789-5021
Charter Communications	951-343-5100
Sprint Communication Company	909-873-8022
Time Warner Telecom	925-953-7093
MWD	213-217-6961

Method of Payment

Full compensation for all costs, including labor, equipment, materials and incidentals, required to comply with the requirements of this section above, including protection of water valves and covers, gas valves and covers, sewer manholes, survey monuments, survey markers and any other utility appurtenances, shall be considered as included in the various items of work, and no additional compensation will be allowed therefor.

Adjustments to Grade for Obstructions

The Contractor shall adjust to finish grade any valve covers encountered within the project limits, as required, for those utility valves that are provided with slip cans and are adjustable without the replacement of parts or the removal of concrete collars. In cases where the owning utility company insists upon upgrades in the standards, or when additional parts or the removal of concrete collars are required for the adjustment, said adjustment will be the responsibility of the owning utility company.

Communication and coordination with the owning utility company shall be the responsibility of the contractor.

For public safety, traffic shall not be allowed on temporary or permanent pavement until all manholes are either adjusted to grade or otherwise protected, as approved by the Engineer. The Contractor shall adjust to grade manholes and valves when and as necessary for the protection of the traveling public during construction, and shall coordinate all work on said facilities with the owning utility companies. This requirement is intended for traffic that is to be allowed on temporary surfaces during the course of construction. Final adjustment to grade will be the responsibility of the owning utility company, except as provided herein.

Said work shall be performed in accordance with Section 15-2.05A, "Frames, Covers, Grates, and Manholes" of the Standard Specifications. Full compensation for adjustment of valve covers shall be considered as included in the contract price paid for asphalt concrete, or applicable items of work in the event that there is no asphalt concrete bid item, and no additional compensation will be allowed therefor.

All existing utility facilities shall be protected from damage by the Contractor's operations.

Unless otherwise provided herein, the owning utility companies will not be obligated to lower their surface utilities (manholes and valve covers) for Contractor's grading, grinding and/or paving operations. The contractor shall lower surface facilities, including manholes and valve covers, to facilitate construction, and the following shall apply:

1. Contractor shall coordinate all work with the utility owner.
2. Contractor shall be responsible for all costs and shall be responsible for any damage caused to the owner's facilities. If the Contractor observes any pre-existing damage to the utility facilities, the Contractor shall notify the Engineer and the utility owner of that damage prior to performing additional work on the facility.
3. Contractor shall, after removing grade rings and covers, arrange for pickup by, or delivery to, the owner's yard. Any and all concrete collars removed by the Contractor shall become the property of the Contractor, and shall be disposed of as specified elsewhere in these special provisions.

4. The Contractor is advised that he is responsible for ensuring that construction materials do not enter the utility owner's facilities. The Contractor shall install traffic bearing steel plates for this purpose, and provide all coordination and transportation necessary. It is recommended that the Contractor request the utility owner to provide such steel plates. If the Contractor provides steel plates, it shall be the Contractor's responsibility to coordinate with the utility owner for the return of the steel plates to the Contractor after final adjustment to grade. If the Contractor utilizes utility owner's steel plates, and if the Contract items of work include adjustment to final grade, the Contractor shall return the steel plates to the Utility owner's yard, or as otherwise arranged with the Utility owner.
5. Prior to paving or covering the plated utility facility, the Contractor shall tie-out the facility utilizing a method acceptable to the utility owner and provide notes and data of all covered facilities to both the utility owner and the Engineer.
6. The Contractor shall notify the utility owner, upon completion of the Contractor's work, when the utility owner may move in to make the final adjustments to grade.
7. The requirements for lowering of surface facilities shall not apply to vaults. The Contractor shall notify the utility owner of the need to make adjustments to such major facilities.
8. The Contractor is reminded that the utility facilities are owned by public and private utility companies that operate their facilities within public rights of way. The utility owner's preferences with regards to the handling of its facilities shall be complied with to the greatest extent feasible.

Method of Payment

Full compensation for initial lowering of surface utilities facilities shall be considered as included in the contract price paid for asphalt concrete, or applicable items of work in the event that there is no asphalt concrete bid item, and no additional compensation will be allowed therefor.

10-1.17

WATER POLLUTION CONTROL (SANTA ANA RIVER BASIN-RISK LEVEL-1:

Throughout the term of this contract, the total land disturbance area of the project site is more than 1 acre. County will submit a Notice of Intent (NOI) to the California Regional Water Quality Board – Santa Ana Region for compliance with the General Permit for Stormwater Discharges Associated with Construction and Land Disturbance Activities (hereafter referred to as the Construction General Permit), which is available at:

(http://www.waterboards.ca.gov/water_issues/programs/stormwater/construction.shtml).

The Area-Wide Municipal Stormwater Permit NPDES No. CAS618033, hereafter referred to in this section as the "Municipal Permit", issued by the California Regional

Water Quality Control Board (CRWQCB) – Santa Ana Region. This permit regulates both stormwater and non-stormwater discharges associated with Contractor's construction activities. A copy of the Permit may be obtained at the office of the County of Riverside Transportation Department, 14th Street Transportation Annex, 3525 14th Street, Riverside, California. (951) 955-6780, or may be obtained on the internet at: <http://www.swrcb.ca.gov/rwqcb8>

The Contractor shall comply with the requirements of Construction General Permit, the Municipal Permit.

Contractor's Stormwater Pollution Prevention Plan and Monitoring Program (SWPPP/MP) shall be prepared by a Qualified SWPPP Developer in accordance with Section 2, "Preparing a Stormwater Pollution Prevention Plan (SWPPP)", of the *Caltrans Stormwater Pollution Prevention Plan (SWPPP) and Water Pollution Control Program (WPCP) Preparation Manual (March 2007)*, which is available as a free download from:

<http://www.dot.ca.gov/hq/construc/stormwater/manuals.htm>

This project is a Risk Level 1 project under the Construction General Permit. Therefore, Contractor's SWPPP/MP shall also conform to Attachment C, Risk Level 1 Requirements of the Construction General Permit.

WATER POLLUTION CONTROL MEASURES

- A. Work having the potential to cause water pollution shall not commence until the Contractor's SWPPP/MP has been reviewed and approved by the Engineer. The Engineer's review and approval of the Contractor's SWPPP/MP shall not waive any contractual requirements and shall not relieve the Contractor from achieving and maintaining compliance with all federal, state, and local laws, ordinances, statutes, rules, and regulations. A copy of Contractor's SWPPP/MP shall be maintained onsite. When the SWPPP/MP or access to the construction site is requested by a representative of a federal, state, or local regulatory agency, Contractor shall make the SWPPP/MP available and Contractor shall immediately contact the Engineer. Requests from the public for the Contractor's SWPPP/MP shall be directed to the Engineer.

- B. Contractor's SWPPP/MP shall describe the Contractor's plan for managing runoff during each construction phase. Contractor's SWPPP/MP shall describe the Best Management Practices (BMPs) that will be implemented to control erosion, sediment, tracking, construction materials, construction wastes, and non-stormwater flows. BMP details shall be based upon California Stormwater Quality Association's 2009 California Stormwater Quality BMP Handbook Portal or the Caltrans Construction Site BMP Manual (<http://www.dot.ca.gov/hq/construc/stormwater/manuals.htm>). Contractor's SWPPP/MP shall describe installation, operation, inspection, maintenance, and monitoring activities that will be implemented for compliance with the Construction General Permit and all applicable federal, state, and local laws,

ordinances, statutes, rules, and regulations related to the protection of water quality.

C. Preparer of Contractor's SWPPP/MP shall have one of the following certifications:

1. A California registered professional civil engineer;
2. A California registered professional geologist or engineering geologist;
3. A California registered landscape architect;
4. A professional hydrologist registered through the American Institute of Hydrology;
5. A Certified Professional in Erosion and Sediment Control™ (CPESC®) registered through EnviroCert International, Inc.; or
6. A Certified Professional in Storm Water Quality™ (CPSWQ®) registered through EnviroCert International, Inc.;

D. Contractor shall designate a Water Pollution Control Manager that shall have one of the certifications in the immediately preceding subsection D or one of the following certifications:

1. A certified erosion, sediment and storm water inspector registered through EnviroCert International, Inc.; or
2. A certified inspector of sediment and erosion control registered through Certified Inspector of Sediment and Erosion Control, Inc.

E. Contractor's Water Pollution Control Manager shall:

1. Be responsible for all water pollution control work.
2. Be the Engineer's primary contact for all water pollution control work.
3. Have the authority to mobilize resources (crews, supplies, equipment, etc.) to make immediate repairs of water pollution control measures or to supplement water pollution control measures to maintain compliance with all federal, state, and local laws, ordinances, and regulations related to the protection of water quality, including the General Permit for Stormwater Discharges Associated with Construction and Land Disturbance Activities.

F. Water Pollution Control Training: Contractor shall provide water pollution control training to Contractor's employees and subcontractors prior to their performing work on the work site. The water pollution control training shall be appropriate to the employee or subcontractor function and area of responsibility and shall address (as applicable):

1. Erosion Control (water and wind)
2. Sediment Control
3. Tracking Control
4. Materials & Waste Management
5. Non-Stormwater Discharge Management

G. Monitoring and Reporting: Observations and inspections conducted by the Contractor's Water Pollution Control Manager shall be documented on the

Construction Site Inspection Checklist included in Contractor's SWPPP/MP. A copy of each completed Construction Site Inspection Checklist shall be submitted to the Engineer within 24 hours of conducting the inspection.

General Requirements:

In the event the County incurs any Administrative Civil Liability (fine) imposed by the CRWQCB – Santa Ana River Basin Region, as a result of Contractor's failure to fully implement the provisions of "Stormwater and Non-Stormwater Pollution Control", the Engineer, may, in the exercise of his sole judgment and discretion, withhold from payments otherwise due Contractor a sufficient amount to cover the Administrative Civil Liability including County staff time, legal counsel, consultant support costs and all other associated cost.

The Contractor shall be responsible for all costs and for any liability imposed by law as a result of the Contractor's failure to comply with the requirements set forth in "Water Pollution Control", including but not limited to, compliance with the applicable provisions of the Caltrans Handbooks, Construction General Permit, Federal, State, and local regulations. For the purpose of this paragraph, costs and liabilities include, but not limited to, fines, penalties, damages, and costs associated with defending against enforcement actions whether taken against the County or the Contractor, including those levied under the Federal Clean Water Act and the State Porter-Cologne Water Quality Act.

Within fifteen (15) working days after the award of the contract, the Contractor shall submit two (2) copies of the SWPPP/MP to the Engineer for review and approval. The Contractor shall allow ten (10) working days for the Engineer to review the SWPPP/MP. If revisions are required as determined by the Engineer, the Contractor shall revise and resubmit the SWPPP/MP within three (3) working days of receipt of the Engineer's comments and shall allow ten (10) working days for the Engineer to review the revisions. The Contractor shall submit four (4) copies of the approved SWPPP/MP to the Engineer prior to notice to proceed. The Contractor must have an approved SWPPP/MP prior to the notice to proceed. The Engineer may provide a letter of conditional approval of the Contractor's SWPPP/MP while minor revisions are made and may allow the Contractor to begin only those certain construction activities identified in the letter of conditional approval. In no case will the conditional approval extend beyond twenty-one (21) calendar days. The Engineer may suspend construction operations until the Contractor submits a revised SWPPP/MP that is reviewed and approved by the Engineer.

The SWPPP shall contain all required and applicable certifications and evidence of training for the Water Pollution Control Manager, SWPPP Developer, and all other employees working on the project receiving formal training or certification.

Unless otherwise directed by the Engineer or specified in these Special Provisions, the Contractor's responsibility for SWPPP/MP implementation shall continue throughout any temporary suspension of work ordered in accordance with Section 8-1.05, "Temporary Suspension of the Work", of the Standard Specifications.

The Engineer may withhold progress payments or order the suspension of construction operations without an extension of the contract time, if the Contractor fails to comply with the requirements of "Water Pollution Control" as determined by the Engineer.

All BMP repairs shall be implemented by the Contractor within 72 hrs. All BMP repairs shall also be implemented by the Contractor prior to a qualifying storm event, as defined in the Construction General Permit.

The Contractor shall be responsible for all the "Risk Level 1 Monitoring and Reporting Requirements" described in the General Construction Permit, which includes (but not limited to):

- a. Risk Level 1 - Visual Monitoring (Inspection) Requirements for Qualifying Rain Events
- b. Risk Level 1 – Monitoring Methods
- c. Risk Level 1 – Non-Storm Water Discharge Monitoring Requirements
- d. Risk Level 1 – Non-Visible Pollutant Monitoring Requirements
- e. Risk Level 1 – Records

~~The Contractor shall be responsible for all of the inspection required by the General Construction Permit (weekly, pre and post storm, quarterly non-stormwater, etc). At the direction, the Contractor shall be responsible for providing any information for annual reporting purposes in electronic format, including inspection reports, photos, NOI, sampling and analysis reports, etc.~~

The Contractor shall be responsible for obtaining coverage under latest adopted version of the De Minimus Permit and provide notification prior to a regulated discharge. Compliance with the De Minimus Permit is required by the Municipal Permit. This permit regulates non-stormwater discharges to surface waters of various types of wastes that pose an insignificant threat to water quality and includes monitoring and reporting requirements. At least 45 days before the start of a new (De Minimus Permit) discharge, the contractor shall submit an application and obtain the authorization letter from the (the Regional Board's) Executive Officer to discharge wastewater to surface waters. The types of wastewater discharges regulated under this Permit include the following discharges:

- a. Construction dewatering wastes;
- b. Wastes associated with well installation, development, test pumping and purging;
- c. Aquifer testing wastes;
- d. Dewatering wastes from subterranean seepage, except for discharges from utility vaults;
- e. Discharges resulting from hydrostatic testing of vessels, pipelines, tanks, etc.;
- f. Discharges resulting from the maintenance of potable water supply pipelines, tanks, reservoirs, etc.;
- g. Discharges resulting from the disinfection of potable water supply pipelines, tanks, reservoirs, etc.;
- h. Discharges from potable water supply systems resulting from initial system startup, routine startup, sampling of influent flow, system failures, pressure releases, etc.;

- i. Discharges from fire hydrant testing or flushing;
- j. Air conditioning condensate;
- k. Swimming pool discharge;
- l. Discharges resulting from diverted stream flows;
- m. Decanted filter backwash wastewater and/or sludge dewatering filtrate water from water treatment facilities; and
- n. Other similar types of wastes as determined by the Regional Water Board Executive Officer, which pose a de minimus threat to water quality yet must be regulated under waste discharge requirements.

At the direction of the Engineer the Contractor shall conduct monitoring, sampling and analysis, and report preparation for conformance with Construction Permit, Municipal Permit, and De Minimus Permit. The Contractor will not be compensated for sampling and analysis work due to the Contractor's failure to properly implement, inspect, maintain, and repair BMPs in conformance with the approved SWPPP/MP and any amendments thereto, or for failing to store construction materials or wastes in watertight conditions.

Each proposal shall have listed therein the name and address of a local certified laboratory within 50 miles of the project site to whom the bidder proposes to subcontract all laboratory sampling and analysis, monitoring and report preparation necessary to comply with the Construction General Permit, De Minimus and the Municipal Permit, in accordance with the Subletting and Subcontracting Fair Practices Act, commencing with Section 4100 of the Public Contract Code. The bidder's attention is invited to other provisions of the Act related to the imposition of penalties for a failure to observe its provisions by using unauthorized subcontractors or by making unauthorized substitutions. The certified laboratory shall have experience with monitoring, sampling and analysis, and report preparation for the Construction General Permit and/or the De Minimus Permit and shall be certified by the State. A list of certified laboratories by the State can be found at:

<http://www.cdph.ca.gov/certlic/labs/Documents/ELAPLablist.xls>

Payment for Water Pollution Control shall be on a lump sum basis and shall include full compensation for the work performed, including obtaining Permit coverage, developing, preparing, revising, obtaining approval of, and amending the SWPPP/MP, implementing, installing, constructing, operating, maintaining, and removing and disposing of temporary BMPs, performing the observations, inspections, sampling, analysis, reporting, and street sweeping, and as specified in the Caltrans Handbooks, Construction General Permit, De Minimus Permit, Municipal Permit and these Special Provisions, and as directed by the Engineer.

Street Sweeping.

The following special provision regarding "Street Sweeping" is being added to the contract document.

GENERAL

Summary

This work includes street sweeping.

The SWPPP/MP shall describe and include the use of street sweeping as a Water Pollution Control practice for sediment control and tracking control. Street sweeping shall also conform to all applicable AQMD requirements.

Submittals

At least 5 working days before starting clearing and grubbing, earthwork, or other activities with the potential for tracking sediment or debris, submit:

- A. The number of street sweepers that will be used as described in the SWPPP/MP.
- B. Type of sweeper technology (or technologies).

Quality Control and Assurance

Retain the following records related to street sweeping and submit weekly to Engineer:

- A. Tracking Inspection Log
- B. Sweeping times and locations.
- C. Quantity of sweeping waste disposal.

CONSTRUCTION

Street Sweepers

Sweepers must use one of these technologies:

- A. Mechanical sweeper followed by a vacuum-assisted sweeper.
- B. Vacuum-assisted dry (waterless) sweeper.
- C. Regenerative-air sweeper.
- or
- D. Sweeping by hand is acceptable in lieu of A, B, and C above.

Operation

Street sweeping shall be conducted at:

- A. Paved roads at job site entrance and exit locations.
- B. Paved areas within the job site that flow to storm drains or water bodies.

Street sweeping shall be conducted, and sweeper(s) shall be available on site or within four hours at any given time, for the following:

- A. During clearing and grubbing activities.
- B. During earthwork activities.
- C. During trenching activities.
- D. During roadway structural section activities.
- E. When vehicles are entering and leaving the job site.

- F. After soil disturbing activities.
- G. After observing offsite tracking of material.

Contractor's Water Pollution Control Manager shall inspect adjacent paved areas at job site entrances and exits and paved roadways within the job site on a minimum daily basis, and more frequently when activities that require street sweeping are being performed. Contractor's Water Pollution Control Manager shall maintain a "Tracking Inspection Log." Street sweeping shall be conducted:

- A. Within 4 hours, if sediment or debris is observed on paved areas or paved roadways.

At least one sweeper, in good working order, must be available for the job at all times when sweeping work may be required.

Perform street sweeping to minimize dust. If dust generation is excessive or sediment pickup is ineffective, water may be used but shall be contained, collected (e.g. vacuum), and properly disposed.

Material collected during street sweeping must be removed and disposed of under Section 7-1.13, "Disposal of Material Outside the Highway Right of Way" of the Standard Specifications.

Full compensation to conform with the requirements of this section shall be considered as included the contract lump sum price paid for Water Pollution Control including furnishing all labor, materials, tools, equipment, and incidentals and for doing all the work involved in street sweeping, including disposal of collected material, as shown on the plans, as specified in the Standard Specifications, these Special Provisions, and as directed by the Engineer. Therefore, no additional compensation will be allowed for street sweeping.

10-1.18 DEVELOP WATER SUPPLY:

Develop water supply shall conform to the provisions of Section 17 of the Standard Specifications and these Special Provisions.

Full compensation for developing water supply and furnishing watering equipment shall be considered as included in the lump sum price paid for develop water supply and no additional compensation will be allowed therefore.

Attention is directed to the requirements of Section 10, "Dust Control". Water in amounts specified by the Engineer will be used for dust control, and the cost thereof will be included in the lump sum price paid for Develop Water Supply.

CLEARING AND GRUBBING:

Clearing and grubbing (including trimming trees, cleaning storm drains inlets/outlets, removal of asphalt concrete dike/rolled berms and asphalt concrete overside drains) shall conform to the provisions in Section 16 of the Standard Specifications.

Vegetation within the graded shoulder, except trees, shall be removed or trimmed as shown on the plans and/or as directed by the Engineer.

Removed vegetation shall be the property of the Contractor and shall be disposed of by the Contractor, as provided in Section 7-1.13 of the Standard Specifications.

Regulatory Requirements

Attention is directed to the Federal Migratory Bird Treaty Act (15 USC 703-711) 50 CFR Part 21 and 50 CFR Part 10, and the California Department of Fish and Game Code Sections 3503, 3513 and 3800, that protect migratory birds, their occupied nests, and their eggs from disturbance or destruction.

Construction

Ground disturbance, tree, shrub and/or vegetation removal that occurs between March 1st and September 1st will not commence until a preconstruction survey for nesting birds has verified that no active nests have been located or the Engineer has approved the beginning of work. If an active nest is located, construction within 500 feet of the nest must be avoided until the nest has been vacated and the young are independent of their parents.

Between March 1st and September 1st, the Contractor shall notify the Engineer 15 working days prior to beginning work disturbing structures, the ground or vegetation. The Engineer will approve the beginning of work disturbing the ground or vegetation between March 1st and September 1st.

The Contractor shall use exclusion techniques directed by the Engineer to prevent migratory birds from nesting in trees within the project limits.

If evidence of bird nesting is discovered, the Contractor shall not disturb the nesting birds or nests until the birds have naturally left the nests. If evidence of migratory bird nesting is discovered after beginning work, the Contractor shall immediately stop work within 500 feet of the nests and notify the Engineer. Work shall not resume until the Engineer provides a written notification that work may begin at or adjacent areas of the discovered bird nest locations.

Attention is directed to Section 8-1.05, "Temporary Suspension of Work" of the Standard Specifications.

Nothing in this section shall relieve the Contractor from providing for public safety in conformance with the provisions in Section 7-1.09, "Public Safety" of the Standard Specifications.

Payment:

Full compensation, except as otherwise provided herein, for conforming to the requirements of this article shall be paid for on a lump sum basis and no additional compensation will be allowed therefor.

10-1.20 REMOVE TRAFFIC STRIPE AND PAVEMENT MARKING:

Where blast cleaning/grinding is used for the removal of painted/thermoplastic traffic stripe, and such removal operation is being performed within 10 feet of a lane occupied by public traffic, the residue including dust shall be removed immediately after contact between the sand and the surface being treated. Such removal shall be by wet abrasive blasting, hydro-blasting or vacuum blasting, and shall comply with AQMD regulations.

Blast cleaning/grinding for removal of traffic stripe shall be feathered out to irregular and varying widths.

Pavement markings shall be removed by blast cleaning a rectangular area, rather than just lettering or markings, so the old message cannot be identified.

After removal of traffic stripes and pavement markings, a fog seal coat shall be applied in conformance with the provisions in Section 37, "Bituminous Seals" of the Standard Specifications and the following:

If removal of existing striping is performed more than 24 hours prior to final striping, the Contractor shall place reflective temporary striping tape throughout the limits of sandblasting, to provide channelization of traffic, for all lanes of travel.

Temporary striping tape shall be removed subsequent to final striping.

Nothing in these Special Provisions shall relieve the Contractor from his responsibilities as provided in Section 7-1.09, "Public Safety," of the Standard Specifications.

The contract unit bid price paid per square foot for Remove Traffic Stripe And Pavement Marking shall include full compensation for furnishing all labor, tools, materials, and equipment and no additional compensation will be allowed therefor.

10-1.21 ROADWAY EXCAVATION:

Roadway excavation shall conform to the provisions of Section 19 of the Standard Specifications and these Special Provisions.

At road connections and at limits of asphalt paving, existing pavement shall be header cut as shown on the plans or as directed by the Engineer. Full compensation for furnishing all labor, tools and doing all the work necessary including grinding, and

sawcutting shall be considered as included in the contract prices paid per ton for the various asphalt concrete items and no additional compensation will be allowed therefor.

Existing pavement including any base material shall be cut back to neat lines and removed as shown on the plans or as directed by the Engineer. Excess material will become the property of the Contractor and will be disposed of as provided in Section 7-1.13 of the Standard Specifications.

Payment:

The contract unit bid price paid per cubic yard for Roadway Excavation shall include full compensation for furnishing all labor, materials, tools, equipment, and incidentals, and for doing all work involved in Roadway Excavation/Earthwork, including sawcutting, hauling, placement and compaction of the excavated material, grading the existing dirt driveways to match the new pavement grade and shoulder as directed by the Engineer and no additional compensation will be allowed therefor.

Relative Compaction:

~~Whenever relative compaction is specified to be determined by Test Method No. Calif. 216, the in-place density may be determined by Test Method No. Calif. 231. The in-place density required by Test Method No. Calif. 312 may be determined by Test Method No. 231. The wet weight or dry weight basis and English Units of Measurement may be used at the option of the Materials Engineer.~~

10-1.22

CLASS 2 AGGREGATE BASE:

Aggregate base shall be Class 2 and shall conform to the provisions in Section 26, "Aggregate Bases" of the Standard Specifications and these Special Provisions and shall meet the gradation requirements for 3/4 inch maximum.

The first paragraph of Section 26-1.02A, "Class 2 Aggregate Base" shall be modified to read:

Aggregate for Class 2 aggregate base shall be free from organic matter and other deleterious matter, and shall be of such nature that it can be compacted readily under watering and rolling to form a firm and stable base. Aggregate may consist of broken and crushed asphalt concrete or Portland cement concrete and may contain crushed aggregate base or other rock materials. The material may contain no more than 3 percent brick by weight as determined by California Test Method 202 as modified: Brick material retained on a No.4 sieve shall be identified visually and separated manually. Brick quantification shall be based on total weight of dry sample. Also, material retained on the No.4 sieve shall contain no more than 15 percent of particles (gravel) that have no more than one fractured face.

The Quality Requirements contained in Section 26-1.02A shall be modified to read:

QUALITY REQUIREMENTS

Test	Contract Compliance
Resistance (R-Value)	
Virgin Rock	78 Minimum
Crushed Miscellaneous	80 Minimum
Sand Equivalent	35 Minimum
Durability Index	35 Minimum
Percentage Wear	
100 Revolutions	15 Maximum
500 Revolutions	52 Maximum

Payment:

Quantities of Aggregate Base will be paid for at the contract price per cubic yard and in accordance with the provisions of Sections 26-1.06 and 26-1.07 of the Standard Specifications.

10-1.23 FINISHING ROADWAY:

Finishing roadway shall conform to Section 22 of the Standard Specifications and these Special Provisions.

Payment:

Full compensation, except as otherwise provided herein, for conforming to the requirements of this article shall be paid for on a lump sum basis and no additional compensation will be allowed therefor.

10-1.24 HOT MIX ASPHALT (HMA):

HMA shall be Type "A" and shall conform to the requirements of Section 39 of the Standard Specifications and the following:

Aggregate grading shall be three-quarter inch (3/4") maximum, medium for base course and three-quarter inch (3/4") maximum, medium for the final course.

The grade of Asphalt Binder shall be PG 70-10

The asphalt lift thickness table, as shown in Section 39-6.01, "General Requirements" of the Standard Specifications, is revised as follows:

Total Thickness Shown on Plans	Minimum No. of Layers	Top Layer Thickness (foot)		Next Lower Layer Thickness (foot)		All Other Lower Layer Thickness (foot)	
		Min.	Max.	Min.	Max.	Min.	Max.
0.24-foot or less ^a	1	-	-	-	-	-	-
0.25-foot	2 ^b	0.12	0.13	0.12	0.13	-	-
0.26 - 0.46 foot	2	0.12	0.21	0.14	0.25	-	-
0.47-foot or more	3 or more	0.15	0.21	0.15	0.25	0.17	0.25

Footnotes to asphalt thickness table are revised as follows:

- a. No Change.
- b. One layer of 0.25 foot thick may be placed as approved by the Engineer. When the Traffic Index specified is 5.5 or below, two layers shall be placed.

Asphalts:

Asphalt shall conform to the provisions in this Section, "Asphalts". Section 92, "Asphalts" of the Standard Specifications shall not apply.

Asphalt shall consist of refined petroleum or a mixture of refined liquid asphalt and refined solid asphalt, prepared from crude petroleum. Asphalt shall be:

1. Free from residues caused by the artificial distillation of coal, coal tar, or paraffin;
2. Free from water;
3. Homogeneous.

General:

The Contractor shall furnish asphalt in conformance with the State of California Department of Transportation's "Certification Program for Suppliers of Asphalt." The Department maintains the program requirements, procedures, and a list of approved suppliers at:

<http://www.dot.ca.gov/hq/esc/Translab/fpm/fpmcoc.htm>

The Contractor shall ensure the safe transportation, storage, use, and disposal of asphalt.

The Contractor shall prevent the formation of carbonized particles caused by overheating asphalt during manufacturing or construction.

Grade:

Performance graded (PG) asphalt binder shall conform to the following:

Property	AASHTO Test Method	Specification Grade		
		PG 64-10	PG 64-16	PG 70-10
Original Binder				
Flash Point, Minimum °C	T48	230	230	230
Solubility, Minimum % ^b	T44	99	99	99
Viscosity at 135 °C, Maximum, Pa s	T316	3.0	3.0	3.0
Dynamic Shear, Test Temp. at 10 rad/s, °C Minimum G*/sin(delta), kPa	T315	64 1.00	64 1.00	70 1.00
RTFO Test ^e , Mass Loss, Maximum, %	T240	1.00	1.00	1.00
RTFO Test Aged Binder				
Dynamic Shear, Test Temp. at 10 rad/s, °C Minimum G*/sin(delta), kPa	T315	64 2.20	64 2.20	70 2.20
Ductility at 25 °C Minimum, cm	T51	75	75	75
PAV ^f Aging, Temperature, °C	R28	100	100	110
RTFO Test and PAV Aged Binder				
Dynamic Shear, Test Temp. at 10 rad/s, °C Maximum G*/sin(delta), kPa	T315	31 ^d 5000	28 ^d 5000	34 ^d 5000
Creep Stiffness, Test Temperature, °C Maximum S-value, Mpa Minimum M-value	T313	0 300 0.300	-6 300 0.300	0 300 0.300

Notes:

- a. Not used.
- b. The Engineer will waive this specification if the supplier is a Quality Supplier as defined by Department's "Certification Program for Suppliers of Asphalt".
- c. The Engineer will waive this specification if the supplier certifies the asphalt binder can be adequately pumped and mixed at temperatures meeting applicable safety standards.
- d. Test the sample at 3 °C higher if it fails at the specified test temperature. G* sin(delta) shall remain 5000 kPa maximum.
- e. "RTFO Test" means the asphaltic residue obtained using the Rolling Thin Film Oven Test, AASHTO Test Method T240 or ASTM Designation: D2827.
- f. "PAV" means Pressurized Aging Vessel.

Performance graded polymer modified asphalt binder (PG Polymer Modified) is:

Performance Graded Polymer Modified Asphalt Binder ^a

Property	AASHTO Test Method	Specification Grade		
		PG 58-34 PM	PG 64-28 PM	PG 76-22 PM
Original Binder				
Flash Point, Minimum °C	T 48	230	230	230
Solubility, Minimum % ^b	T 44 ^c	98.5	98.5	98.5
Viscosity at 135°C, ^d Maximum, Pa·s	T 316	3.0	3.0	3.0
Dynamic Shear, Test Temp. at 10 rad/s, °C Minimum G*/sin(delta), kPa	T 315	58 1.00	64 1.00	76 1.00
RTFO Test, Mass Loss, Maximum, %	T 240	1.00	1.00	1.00
RTFO Test Aged Binder				
Dynamic Shear, Test Temp. at 10 rad/s, °C Minimum G*/sin(delta), kPa	T 315	58 2.20	64 2.20	76 2.20
Dynamic Shear, Test Temp. at 10 rad/s, °C Maximum (delta), %	T 315	Note e 80	Note e 80	Note e 80
Elastic Recovery ^f , Test Temp., °C Minimum recovery, %	T 301	25 75	25 75	25 65
PAV ^g Aging, Temperature, °C	R 28	100	100	110
RTFO Test and PAV Aged Binder				
Dynamic Shear, Test Temp. at 10 rad/s, °C Maximum G*/sin(delta), kPa	T 315	16 5000	22 5000	31 5000
Creep Stiffness, Test Temperature, °C Maximum S-value, MPa Minimum M-value	T 313	-24 300 0.300	-18 300 0.300	-12 300 0.300

Notes:

- a. Do not modify PG Polymer Modified using acid modification.
- b. The Engineer waives this specification if the supplier is a Quality Supplier as defined by the Department's "Certification Program for Suppliers of Asphalt."
- c. The Department allows ASTM D 5546 instead of AASHTO T 44
- d. The Engineer waives this specification if the supplier certifies the asphalt binder can be adequately pumped and mixed at temperatures meeting applicable safety standards.
- e. Test temperature is the temperature at which G*/sin(delta) is 2.2 kPa. A graph of log G*/sin(delta) plotted against temperature may be used to determine the test temperature when G*/sin(delta) is 2.2 kPa. A graph of (delta) versus temperature may be used to determine delta at the temperature when G*/sin(delta) is 2.2 kPa. The Engineer also accepts direct measurement of (delta) at the temperature when G*/sin(delta) is 2.2 kPa.
- f. Tests without a force ductility clamp may be performed.
- g. "PAV" means Pressurized Aging Vessel.

Sampling:

Provide a sampling device in the asphalt feed line connecting the plant storage tanks to the asphalt weighing system or spray bar. Make the sampling device accessible between 24 and 30 inches above the platform. Provide a receptacle for flushing the sampling device.

Include with the sampling device a valve:

1. Between 1/2 and 3/4 inch in diameter
2. Manufactured in a manner that a one-quart sample may be taken slowly at any time during plant operations
3. Maintained in good condition

Replace failed valves.

In the Engineer's presence, take 2 one-quart samples per operating day. Provide round, friction top, one-quart containers for storing samples.

Applying Asphalt:

Unless otherwise specified, the Contractor shall heat and apply asphalt in conformance with the provisions in Section 93, "Liquid Asphalts" of the Standard Specifications.

Section 39-2.01, "Asphalts" is replaced in its entirety with the following:

Asphalt binder to be mixed with aggregate shall conform to the provisions in "Asphalts" of these Special Provisions.

The grade of asphalt binder shall be: PG 70-10

Liquid asphalt for prime coat shall conform to the provisions in Section 93, "Liquid Asphalts" of the Standard Specifications and shall be Grade PG 64-10 unless otherwise designated by the contract item or otherwise specified in the Special Provisions.

Asphaltic emulsion for paint binder (tack coat) shall conform to the provisions in Section 94, "Asphaltic Emulsion" of the Standard Specifications for the rapid-setting or slow-setting type and grade approved by the Engineer.

Section 39-3.01B (1) shall be amended to include:

Aggregate of the 3/4 inch or 1/2 inch maximum size and aggregate for asphalt concrete base shall be separated into 3 or more sizes and each size shall be stored in separate bins. If 3 sizes are used, one bin shall contain that portion of the material which will pass the maximum size specified and be retained on a 3/8 inch sieve; one bin shall contain that portion of the material which will pass a 3/8 inch sieve and be retained on a No. 8 sieve; and one bin shall contain that portion of the material which will pass a No. 8 sieve.

Aggregate of 3/8 inch maximum size shall be separated into 2 sizes and each size shall be stored in separate bins. One bin shall contain that portion of the material which will pass the maximum size specified and be retained on a No. 8 sieve and one bin shall contain that portion of the material which will pass a No. 8 sieve.

The bin containing the fine material shall not contain more than 15 percent of material retained on the No. 8 sieve. The material in any of the other bins shall not contain more than 15 percent of material passing a No. 8 sieve. Failure to comply with this requirement shall be corrected immediately, and the material in the bins not meeting these requirements shall be re-screened or wasted.

All asphalt concrete for this project shall be supplied from one source unless approved by the Engineer. Said source shall be listed on the Contractor Source of Materials List as required in Section 6 of the Standard Specifications.

Asphaltic emulsion shall be furnished and applied as provided in Section 39-4.02.

Asphalt concrete driveway approaches shall be reconstructed to match existing as directed by the Engineer.

Unless otherwise specified on the plans, asphalt concrete placed on driveways shall be two and a half inches (2 1/2") in thickness and will be paid for at the same unit price as for material placed on the roadbed.

In addition to the provisions in Section 39-5.01, "Spreading Equipment" of the Standard Specifications, asphalt paving equipment shall be equipped with automatic screed controls and a sensing device or devices.

When placing asphalt concrete to the lines and grades established by the Engineer, the automatic controls shall control the longitudinal grade and transverse slope of the screed. Grade and slope references shall be furnished, installed, and maintained by the Contractor. The Contractor shall use a ski device with a minimum length of 30 feet or as directed by the Engineer. The ski device shall be a rigid one piece unit and the entire length shall be utilized in activating the sensor.

When placing the initial mat of asphalt concrete on existing pavement, the end of the screed nearest the centerline shall be controlled by a sensor activated by a ski device not less than 30 feet. The end of the screed farthest from centerline shall be controlled by an automatic transverse slope device set to reproduce the cross slope designated by the Engineer, by a sensor activated by a similar ski device or as directed by the Engineer.

When paving contiguously with previously placed mats, the end of the screed adjacent to the previously placed mat shall be controlled by a sensor that responds to the grade of the previously placed mat and will reproduce the grade in the new mat within a 0.12 inch tolerance. The end of the screed farthest from the previously placed mat shall be controlled in the same way it was controlled when placing the initial mat.

Should the methods and equipment furnished by the Contractor fail to produce a layer of asphalt concrete conforming to the provisions, including straightedge tolerance, of

Section 39-6.03, "Compacting" of the Standard Specifications or elsewhere in these Special Provisions, the paving operations shall be discontinued and the Contractor shall modify the equipment or methods, or furnish substitute equipment.

Should the automatic screed controls fail to operate properly during a day's work, the Contractor may manually control the spreading equipment for the remainder of that day. However, the equipment shall be corrected or replaced with alternative automatically controlled equipment conforming to the provisions in this section before starting another day's work.

General Criteria For Profiling:

In addition to the straightedge provisions in Section 39-6.03, "Compacting" of the Standard Specifications, asphalt concrete pavement shall conform to the surface tolerances specified herein.

The uppermost layer of asphalt concrete surfacing shall be profiled in the presence of the Engineer using a California Profilograph or equivalent in conformance with California Test 526 and as specified in these Special Provisions.

The California Profilograph or equivalent will not be required for the following areas of the pavement surface but shall conform to the straightedge requirements in Section 39-6.03, "Compacting" of the Standard Specifications:

1. Pavement with a total thickness less than 0.24 foot;
2. Pavement on horizontal curves with a centerline curve radius of less than 1,000 feet and the pavement within the superelevation transition on those curves;
3. Pavement placed in a single lift when required by the Special Provisions;
4. Pavement with extensive grade or cross slope correction which does not receive advance leveling operations in conformance with the provisions in Section 39-6.02, "Spreading" of the Standard Specifications;
5. Pavement for ramps and connectors with steep grades and high rates of superelevation, as determined by the Engineer;
6. Shoulders and miscellaneous areas.

The Contractor shall conform to California Test 526, except a zero (null) blanking band shall be used for determining the Profile Index. Prior to beginning profiles, the profilograph shall be calibrated in the presence of the Engineer. Two profiles shall be obtained within each traffic lane, 3 feet from and parallel with the edges of the lane.

Pavements profiled shall conform to the following Profile Index requirements:

1. Pavement on tangent alignment and pavement on horizontal curves having a centerline curve radius of 2,000 feet or more shall have a Profile Index of 0.16 foot or less for each 330 feet section profiled;
2. Pavement on horizontal curves having a centerline curve radius of 1,000 feet or more but less than 2,000 feet, including the pavement within the superelevation transition of these curves, shall have a Profile Index of 0.32 foot or less for each 330 feet section profile;
3. Pavement within any 330 feet section, containing high point areas with deviations in excess of 0.025 foot in a length of 25 feet or less, when tested in conformance with the requirements in California Test 526, shall be corrected by the Contractor regardless of the Profile Index.

The Contractor shall complete initial runs of the profilograph prior to opening the pavement to public traffic. If initial profiles can not be made prior to opening the pavement to public traffic, the initial runs of the profilograph shall be made the next day that traffic control is permitted for the area to be profiled.

Areas of the top surface of the uppermost layer of asphalt concrete pavement that do not meet the specified surface tolerances shall be brought within tolerance by abrasive grinding.

Abrasive grinding shall be performed to reduce individual deviations in excess of 0.025 foot, and to reduce the Profile Index of the pavement to be within the specified tolerance. Areas which have been subjected to abrasive grinding shall receive a seal coat. Deviations in excess of 0.025 foot which cannot be brought into specified tolerance by abrasive grinding shall be corrected by either (1) removal and replacement or (2) placing an overlay of asphalt concrete. The corrective method for each area shall be selected by the Contractor and shall be approved by the Engineer prior to beginning the corrective work. Replacement or overlay pavement not meeting the specified tolerances shall be corrected by the methods specified above. Corrective work shall be at the Contractor's expense. The Contractor shall run profilograms on the areas that have received abrasive grinding or corrective work until the final profilograms indicate the Profile Index of the area is within the specified tolerance.

When abrasive grinding is used to bring the top surface of the uppermost layer of asphalt concrete surfacing within the specified surface tolerances, additional abrasive grinding shall be performed as necessary to extend the area ground in each lateral direction so that the lateral limits of grinding are at a constant offset from, and parallel with, the nearest lane line or pavement edge, and in each longitudinal direction so that the grinding begins and ends at lines normal to the pavement centerline, within a ground area. Ground areas shall be neat rectangular areas of uniform surface appearance.

The original of the final profilograms that indicate the pavement surface is within the Profile Index specified shall become the property of the County and shall be delivered to the Engineer prior to acceptance of the contract.

Payment:

HMA will be paid for at a unit price per ton as a combined item, including mineral aggregate and asphalt binder in place on the roadbed.

Full compensation for furnishing and applying asphaltic emulsion (paint binder) shall be considered as included in the contract price paid for HMA.

10-1.25 ASPHALT CONCRETE DIKE AND OVERSIDE DRAIN:

Asphalt concrete dikes and overside drains shall be constructed in accordance to the Caltrans Standard Plans or Riverside County Road Improvement Standards And Specifications, as specified and as directed by the Engineer.

The pay quantity of asphalt concrete dikes and overside drains, the placing of which are to be paid for as a separate item of work in addition to the price paid for the asphalt concrete material.

The contract unit bid prices paid per linear foot for Asphalt Concrete Dike and per each for Asphalt Concrete Overside Drain, which prices shall include full compensation for furnishing all labor, material, tools, and equipment and doing all the work involved in placing and compacting and no additional compensation will be allowed therefor.

Asphalt binder to be mixed with the aggregate shall be PG 70-10 in accordance with the Special Provisions for Asphalts, or as directed by the Engineer.

10-1.26 COMPENSATION ADJUSTMENTS FOR PRICE INDEX FLUCTUATIONS:

The provisions of this section shall apply only to the following contract items:

ITEM CODE	ITEM
390130	Hot Mix Asphalt

The compensation payable for asphalt binder used in hot mix asphalt and tack coat will be increased or decreased in conformance with the provisions of this section for paving asphalt price fluctuations exceeding 10 percent (Iu/Ib is greater than 1.10 or less than 0.90) which occur during performance of the work.

The quantity of asphalt binder used in tack coat will be determined by multiplying the item quantity for tack coat included in a monthly estimate by the minimum percent residue specified in Section 94, "Asphaltic Emulsions" of the Standard Specifications. The asphaltic emulsion minimum percent residue will be based on the type of emulsion used by the Contractor.

At the Contractor's option, the Contractor may provide actual daily test results for asphalt binder residue for the tack coat used. Test results provided by the Contractor

shall be from an independent testing laboratory that participates in the AASHTO Proficiency Sample Program. The Contractor shall take samples of asphaltic emulsion from the distributor truck at mid-load from a sampling tap or thief. Two separate one-half (½) gallon samples shall be taken in the presence of the Engineer. The Contractor shall provide one sample to the Contractor's independent testing laboratory within 24 hours of sampling. The second sample shall be given to the Engineer. The test results from the Contractor independent testing laboratory shall be delivered to the Engineer within 10 days from sample date.

The adjustment in compensation will be determined in conformance with the following formulae when the item of hot mix asphalt or tack coat or both are included in a monthly estimate:

- A. Total monthly adjustment = AQ
- B. For an increase in paving asphalt price index exceeding 10 percent:

$$A = 0.90 (I_u/I_b - 1.10) I_b$$

- C. For a decrease in paving asphalt price index exceeding 10 percent:

$$A = 0.90 (I_u/I_b - 0.90) I_b$$

- D. Where:

A = Adjustment in dollars per ton of paving asphalt used to produce hot mix asphalt and asphaltic emulsion residue used as tack coat rounded to the nearest \$0.01.

I_u = The California Statewide Paving Asphalt Price Index which is in effect on the first business day of the month within the pay period in which the quantity subject to adjustment was included in the estimate.

I_b = The California Statewide Paving Asphalt Price Index for the month in which the bid opening for the project occurred.

Q = Quantity in tons of asphalt binder that was used in producing the quantity of hot mix asphalt shown under "This Estimate" on the monthly estimate using the amount of asphalt binder determined by the Engineer plus the quantity in tons of asphalt binder that would have been used as residue in the tack coat shown under "This Estimate" on the monthly estimate.

The adjustment in compensation will also be subject to the following:

- A. The compensation adjustments provided herein will be shown separately on payment estimates. The Contractor shall be liable to the State for decreased compensation adjustments and the Department may deduct the amount thereof from moneys due or that may become due the Contractor.

- B. Compensation adjustments made under this section will be taken into account in making adjustments in conformance with the provisions in Section 4-1.03B, "Increased or Decreased Quantities" of the Standard Specifications.
- C. In the event of an overrun of contract time, adjustment in compensation for paving asphalt included in estimates during the overrun period will be determined using the California Statewide Paving Asphalt Price Index in effect on the first business day of the month within the pay period in which the overrun began.

The California Statewide Paving Asphalt Price Index is determined each month on the first business day of the month by the Department using the median of posted prices in effect as posted by Chevron, Mobil, and Unocal for the Buena Vista, Huntington Beach, Kern River, Long Beach, Midway Sunset, and Wilmington fields.

In the event that the companies discontinue posting their prices for a field, the Department will determine an index from the remaining posted prices. The Department reserves the right to include in the index determination the posted prices of additional fields.

The California Statewide Paving Asphalt Price Index is available on the Division of Engineering Services website at:
http://www.dot.ca.gov/hq/esc/oe/asphalt_index/astable.html

10-1.27

RUMBLE STRIP:

Construction of rumble strips by ground-in indentations shall be per Caltrans Plan No. A40B, modified. Length, width, depth and spacing shall be per standard, modified with placement centered on centerline of road. Indentation shall be completed prior to striping. Centerline striping and RPM placement shall be per Riverside County standards.

Refer to plans for station numbering limits.

Select the method and equipment for constructing ground-in indentations.

Ground-in equipment must be equipped with a sighting device enabling the operator to maintain the rumble strip alignment.

Indentations must not vary from the specified dimensions by more than 1/16 inch in depth or more than 10 percent in length and width.

The Engineer orders grinding or removal and replacement of noncompliant rumble strips to bring them within specified tolerances. Ground surface areas must be neat and uniform in appearance.

The grinding equipment must be equipped with a vacuum attachment to remove residue.

Dispose of removed material under Section 7-1.13 of the Standard Specifications, "Disposal of Material Outside the Highway Right of Way", and "Disposal of Excess Excavation or Materials" of these special provisions.

The contract unit bid price paid per linear foot for Rumble Strips. Bid Item shall include full compensation for furnishing all labor, materials, tools, equipment, and incidentals, for doing all the work involved and no additional compensation will be allowed therefor.

10-1.28 SHOULDER BACKING:

Shoulder backing shall provide for the grading of the shoulder as per plans, or as directed by the Engineer. Unless otherwise specified, the width of the graded shoulder/shoulder backing shall be four feet minimum, measured from the edge of pavement.

Onsite material may be used to fill in low areas, subject to approval by the Engineer. Ground asphalt concrete may be used subject to the Engineer's approval.

Ground asphalt concrete shall not be placed in or in close proximity to streambeds or drainage courses, the limits of which shall be determined by the Engineer.

Imported material, if required to fill in low areas, shall conform to the provisions of Section 25, "Aggregate Subbases" of the Standard Specifications and these Special Provisions, and the aggregate shall conform to the grading and quality requirements for Class 1 aggregate subbases.

Subbase material shall be clean and free from roots, vegetable matter and other deleterious substances, and be of such character that when wet it will compact to form a firm stable base. The material shall be of such sizes that the percentage composition by weight of material shall conform to the aggregate grading requirements at the time the material is deposited on the roadbed when determined by Test Method No. Calif. 202.

Payment for Shoulder Backing will be paid at the linear foot price bid and shall include full compensation for furnishing all labor, materials, tools, and equipment, including the importing of material and/or the handling of onsite material, and no separate payment will be allowed therefor.

10-1.29 PAINT TRAFFIC STRIPE:

Painting traffic stripe shall conform to the provisions in Sections 84-1, "General" and 84-3, "Painted Traffic Stripes and Pavement Markings" of the Standard Specifications and these Special Provisions.

Traffic striping shall be applied in two coats with airless equipment and shall be performed with a roadliner truck mounted striping machine. Where the configuration or

location of a traffic stripe is such that the use of a roadliner truck mounted striping machine is unsuitable, traffic striping and glass spheres may be applied by other methods and equipment approved by the Engineer.

Newly painted traffic striping shall be protected from damage by public traffic or other causes until the paint is thoroughly dry. Any newly painted traffic striping which are damaged as a result of the construction, including wheel markings by public traffic and the construction equipment, shall be repainted by the Contractor and any associated removals shall be performed as called for in these Special Provisions.

The contract price paid per linear foot for Paint Traffic Stripe (2 Coats) shall include full compensation for furnishing all labor, materials, tools, equipment, and incidentals, and for doing all the work involved in painting traffic stripe (regardless of the number, widths, and types of individual stripes involved in each traffic stripe) including any necessary cat tracks, dribble lines any layout work, complete in place as shown on the plans, as specified in the Standard Specifications and these Special Provisions, and as directed by the Engineer.

10-1.30 THERMOPLASTIC PAVEMENT MARKING:

Thermoplastic pavement markings shall conform to the provisions in Sections 84-1, "General," and 84-2, "Thermoplastic Traffic Stripes and Pavement Markings," of the Standard Specifications and these Special Provisions.

Payment for Thermoplastic Pavement Marking shall be paid by the square foot price bid and shall be considered as full compensation for furnishing all labor, materials, tools, equipment, and incidentals and doing all the work necessary to place the pavement markings complete in place and no additional compensation will be allowed.

10-1.31 PAVEMENT MARKER AND OBJECT MARKER:

Pavement markers shall conform to the provisions in Section 85, "Pavement Markers" of the Standard Specifications and these Special Provisions.

Object markers shall conform to the provisions in Section 82, "Markers and Delineators" of the Standard Specifications and these Special Provisions. Object markers shall be installed as indicated on the plans.

Pavement markers shall be placed to the line established by the Engineer. All additional work necessary to establish satisfactory lines for markers shall be performed by the Contractor.

Pavement markers shall be installed where indicated on the plans in accordance with the indicated striping detail. Refer to Standard Plans A20-A through A20-D for striping and markings details.

Markers and adhesive removal shall be performed by a method approved by the Engineer. Any pavement scarring resulting from the markers removal shall be repaired to the satisfaction of the Engineer.

Payment for furnishing and placing Pavement Markers will be at the unit price bid and shall include full compensation for furnishing all labor, materials, tools, equipment, and incidentals, and for doing all the work involved including the removal of existing pavement markers and no additional compensation will be allowed therefor.

10-1.32 ROADSIDE SIGNS (INSTALL/RELOCATE):

Roadside signs (install/relocate) shall conform to the provisions in Section 56-2, "Roadside Signs" of the Standard Specifications and as directed by the Engineer.

Roadside signs shall be installed at the locations shown on the construction plans or where directed by the Engineer.

Roadside signs furnished by the Contractor shall be of the standard size specified in the State of California Department of Transportation Sign Specification Sheets, unless otherwise indicated on the construction plans.

Sheeting shall be guaranteed against defects for a period of ten years from the date of fabrication.

The base metal shall be new aluminum, 0.08 gauge, of alloys 6061-T6 or 5052-H38 conforming to the requirements of ASTM Designation: B209.

Any reflective sheeting supplied as a part of this contract, whether as a legend or background, shall be FHWA FP-85 Type IIA or AASHTO M268 Type III.

Reflective sheeting shall be applied to the sign by a method approved by the manufacturer of the sheeting and shall produce a durable bond equal to or greater than the strength of the reflective sheeting. No air pockets or bubbles shall exist between the sheeting and aluminum backing.

The reflective material and screening inks or overlay film shall be graffiti proof. The graffiti proofing method shall be supplied by and/or approved by the sheeting manufacturer. Neither the color nor the reflective intensity of the finished sign shall be significantly diminished by the use of graffiti remover when used in a manner approved by the Transportation Department in conjunction with the sheeting manufacturer. Any signs graffitied by over the counter spray paint or marking pens, which fail to be restored, shall be replaced by the sign sheeting manufacturer.

All letters and numerals shall be in accordance with the "Standard Alphabet of Highway Signs" as used by the State of California, Department of Transportation.

All signs shall be installed using hex head bolts, washers, nuts and jam nuts in accordance with Standard Plans RS2 or as directed by the Engineer.

The contract unit prices paid per each for Roadside Signs (Install/Relocate) shall include full compensation for furnishing all labor, materials, tools, equipment, and incidentals and for doing all the work including all necessary concrete, excavation and backfill as specified in the Standard Specification and these Special Provisions and no additional compensation will be allowed therefor.

10-1.33 DE-MOBILIZATION:

De-mobilization shall consist of the completion of all final construction and administrative work required to secure the project for termination and acceptance by the Engineer, including, but not limited to the following:

1. Satisfactory completion of Finishing Roadway in accordance with Section 22, "Finishing Roadway" of the Standard Specifications;
2. Removal of all temporary facilities, construction office, temporary utilities, plant, equipment, surplus material, construction debris and similar from project limits and adjacent property, as required and as directed by the Engineer;
3. Restoration of all temporary roads and haul routes and construction storage and office areas, etc. to original or better condition;
4. Completion of record of drawings (as-builts), to the satisfaction of the Engineer;
5. Submission of final Disadvantaged Business Enterprise report to the Engineer;
6. Submission of final certified payroll documents to the Engineer;
7. Submission of property owner releases, as required by the Engineer;
8. Completion of the requirements of permits issued by other agencies;
9. Satisfactory completion of all other contractually and legally required construction and administrative items of work.

De-Mobilization shall include the satisfactory completion of all items of work, but shall not be construed as being a separate payment for work that is paid under separate contract items. The contract item for De-Mobilization is intended for proper close-out activities.

Payment for De-Mobilization will be made on a lump sum basis in the amount of the fixed bid price after satisfactory completion of the above listed items. Payment for De-Mobilization will be included in the final pay estimate and payment. No partial payments will be made for De-Mobilization.

APPENDIX A
Attachment "C" for Risk Level 1 Requirements
Of Water Pollution Control

ATTACHMENT C RISK LEVEL 1 REQUIREMENTS

A. Effluent Standards

[These requirements are the same as those in the General Permit order.]

1. Narrative – Risk Level 1 dischargers shall comply with the narrative effluent standards listed below:
 - a. Storm water discharges and authorized non-storm water discharges regulated by this General Permit shall not contain a hazardous substance equal to or in excess of reportable quantities established in 40 C.F.R. §§ 117.3 and 302.4, unless a separate NPDES Permit has been issued to regulate those discharges.
 - b. Dischargers shall minimize or prevent pollutants in storm water discharges and authorized non-storm water discharges through the use of controls, structures, and management practices that achieve BAT for toxic and non-conventional pollutants and BCT for conventional pollutants.
2. Numeric – Risk Level 1 dischargers are not subject to a numeric effluent standard.

B. Good Site Management "Housekeeping"

1. Risk Level 1 dischargers shall implement good site management (i.e., "housekeeping") measures for construction materials that could potentially be a threat to water quality if discharged. At a minimum, Risk Level 1 dischargers shall implement the following good housekeeping measures:
 - a. Conduct an inventory of the products used and/or expected to be used and the end products that are produced and/or expected to be produced. This does not include materials and equipment that are designed to be outdoors and exposed to environmental conditions (i.e. poles, equipment pads, cabinets, conductors, insulators, bricks, etc.).
 - b. Cover and berm loose stockpiled construction materials that are not actively being used (i.e. soil, spoils, aggregate, fly-ash, stucco, hydrated lime, etc.).

- c. Store chemicals in watertight containers (with appropriate secondary containment to prevent any spillage or leakage) or in a storage shed (completely enclosed).
 - d. Minimize exposure of construction materials to precipitation. This does not include materials and equipment that are designed to be outdoors and exposed to environmental conditions (i.e. poles, equipment pads, cabinets, conductors, insulators, bricks, etc.).
 - e. Implement BMPs to prevent the off-site tracking of loose construction and landscape materials.
2. Risk Level 1 dischargers shall implement good housekeeping measures for waste management, which, at a minimum, shall consist of the following:
- a. Prevent disposal of any rinse or wash waters or materials on impervious or pervious site surfaces or into the storm drain system.
 - b. Ensure the containment of sanitation facilities (e.g., portable toilets) to prevent discharges of pollutants to the storm water drainage system or receiving water.
 - c. Clean or replace sanitation facilities and inspecting them regularly for leaks and spills.
 - d. Cover waste disposal containers at the end of every business day and during a rain event.
 - e. Prevent discharges from waste disposal containers to the storm water drainage system or receiving water.
 - f. Contain and securely protect stockpiled waste material from wind and rain at all times unless actively being used.
 - g. Implement procedures that effectively address hazardous and non-hazardous spills.
 - h. Develop a spill response and implementation element of the SWPPP prior to commencement of construction activities. The SWPPP shall require that:
 - i. Equipment and materials for cleanup of spills shall be available on site and that spills and leaks shall be cleaned up immediately and disposed of properly; and

- ii. Appropriate spill response personnel are assigned and trained.
 - i. Ensure the containment of concrete washout areas and other washout areas that may contain additional pollutants so there is no discharge into the underlying soil and onto the surrounding areas.
3. Risk Level 1 dischargers shall implement good housekeeping for vehicle storage and maintenance, which, at a minimum, shall consist of the following:
 - a. Prevent oil, grease, or fuel to leak in to the ground, storm drains or surface waters.
 - b. Place all equipment or vehicles, which are to be fueled, maintained and stored in a designated area fitted with appropriate BMPs.
 - c. Clean leaks immediately and disposing of leaked materials properly.
4. Risk Level 1 dischargers shall implement good housekeeping for landscape materials, which, at a minimum, shall consist of the following:
 - a. Contain stockpiled materials such as mulches and topsoil when they are not actively being used.
 - b. Contain fertilizers and other landscape materials when they are not actively being used.
 - c. Discontinue the application of any erodible landscape material within 2 days before a forecasted rain event or during periods of precipitation.
 - d. Apply erodible landscape material at quantities and application rates according to manufacture recommendations or based on written specifications by knowledgeable and experienced field personnel.
 - e. Stack erodible landscape material on pallets and covering or storing such materials when not being used or applied.
5. Risk Level 1 dischargers shall conduct an assessment and create a list of potential pollutant sources and identify any areas of the site where additional BMPs are necessary to reduce or prevent pollutants in storm water discharges and authorized non-storm water discharges. This potential pollutant list shall be kept with the SWPPP and shall identify

all non-visible pollutants which are known, or should be known, to occur on the construction site. At a minimum, when developing BMPs, Risk Level 1 dischargers shall do the following:

- a. Consider the quantity, physical characteristics (e.g., liquid, powder, solid), and locations of each potential pollutant source handled, produced, stored, recycled, or disposed of at the site.
 - b. Consider the degree to which pollutants associated with those materials may be exposed to and mobilized by contact with storm water.
 - c. Consider the direct and indirect pathways that pollutants may be exposed to storm water or authorized non-storm water discharges. This shall include an assessment of past spills or leaks, non-storm water discharges, and discharges from adjoining areas.
 - d. Ensure retention of sampling, visual observation, and inspection records.
 - e. Ensure effectiveness of existing BMPs to reduce or prevent pollutants in storm water discharges and authorized non-storm water discharges.
6. Risk Level 1 dischargers shall implement good housekeeping measures on the construction site to control the air deposition of site materials and from site operations. Such particulates can include, but are not limited to, sediment, nutrients, trash, metals, bacteria, oil and grease and organics.

C. Non-Storm Water Management

1. Risk Level 1 dischargers shall implement measures to control all non-storm water discharges during construction.
2. Risk Level 1 dischargers shall wash vehicles in such a manner as to prevent non-storm water discharges to surface waters or MS4 drainage systems.
3. Risk Level 1 dischargers shall clean streets in such a manner as to prevent unauthorized non-storm water discharges from reaching surface water or MS4 drainage systems.

D. Erosion Control

1. Risk Level 1 dischargers shall implement effective wind erosion control.
2. Risk Level 1 dischargers shall provide effective soil cover for inactive¹ areas and all finished slopes, open space, utility backfill, and completed lots.
3. Risk Level 1 dischargers shall limit the use of plastic materials when more sustainable, environmentally friendly alternatives exist. Where plastic materials are deemed necessary, the discharger shall consider the use of plastic materials resistant to solar degradation.

E. Sediment Controls

1. Risk Level 1 dischargers shall establish and maintain effective perimeter controls and stabilize all construction entrances and exits to sufficiently control erosion and sediment discharges from the site.
2. On sites where sediment basins are to be used, Risk Level 1 dischargers shall, at minimum, design sediment basins according to the method provided in CASQA's Construction BMP Guidance Handbook.

F. Run-on and Runoff Controls

Risk Level 1 dischargers shall effectively manage all run-on, all runoff within the site and all runoff that discharges off the site. Run-on from off site shall be directed away from all disturbed areas or shall collectively be in compliance with the effluent limitations in this General Permit.

G. Inspection, Maintenance and Repair

1. Risk Level 1 dischargers shall ensure that all inspection, maintenance repair and sampling activities at the project location shall be performed or supervised by a Qualified SWPPP Practitioner (QSP) representing the discharger. The QSP may delegate any or all of these activities to an employee trained to do the task(s) appropriately, but shall ensure adequate deployment.
2. Risk Level 1 dischargers shall perform weekly inspections and observations, and at least once each 24-hour period during extended

¹ Inactive areas of construction are areas of construction activity that have been disturbed and are not scheduled to be re-disturbed for at least 14 days.

storm events, to identify and record BMPs that need maintenance to operate effectively, that have failed, or that could fail to operate as intended. Inspectors shall be the QSP or be trained by the QSP.

3. Upon identifying failures or other shortcomings, as directed by the QSP, Risk Level 1 dischargers shall begin implementing repairs or design changes to BMPs within 72 hours of identification and complete the changes as soon as possible.
4. For each inspection required, Risk Level 1 dischargers shall complete an inspection checklist, using a form provided by the State Water Board or Regional Water Board or in an alternative format.
5. Risk Level 1 dischargers shall ensure that checklists shall remain onsite with the SWPPP and at a minimum, shall include:
 - a. Inspection date and date the inspection report was written.
 - b. Weather information, including presence or absence of precipitation, estimate of beginning of qualifying storm event, duration of event, time elapsed since last storm, and approximate amount of rainfall in inches.
 - c. Site information, including stage of construction, activities completed, and approximate area of the site exposed.
 - d. A description of any BMPs evaluated and any deficiencies noted.
 - e. If the construction site is safely accessible during inclement weather, list the observations of all BMPs: erosion controls, sediment controls, chemical and waste controls, and non-storm water controls. Otherwise, list the results of visual inspections at all relevant outfalls, discharge points, downstream locations and any projected maintenance activities.
 - f. Report the presence of noticeable odors or of any visible sheen on the surface of any discharges.
 - g. Any corrective actions required, including any necessary changes to the SWPPP and the associated implementation dates.
 - h. Photographs taken during the inspection, if any.
 - i. Inspector's name, title, and signature.

H. Rain Event Action Plan

Not required for Risk Level 1 dischargers.

I. Risk Level 1 Monitoring and Reporting Requirements

Table 1- Summary of Monitoring Requirements

Risk Level	Visual Inspections				Sample Collection		
	Quarterly Non-storm Water Discharge	Pre-storm Event		Daily Storm BMP	Post Storm	Storm Water Discharge	Receiving Water
		Baseline	REAP				
1	X	X		X	X		

1. Construction Site Monitoring Program Requirements

- a. Pursuant to Water Code Sections 13383 and 13267, all dischargers subject to this General Permit shall develop and implement a written site-specific Construction Site Monitoring Program (CSMP) in accordance with the requirements of this Section. The CSMP shall include all monitoring procedures and instructions, location maps, forms, and checklists as required in this section. The CSMP shall be developed prior to the commencement of construction activities, and revised as necessary to reflect project revisions. The CSMP shall be a part of the Storm Water Pollution Prevention Plan (SWPPP), included as an appendix or separate SWPPP chapter.
- b. Existing dischargers registered under the State Water Board Order No. 99-08-DWQ shall make and implement necessary revisions to their Monitoring Programs to reflect the changes in this General Permit in a timely manner, but no later than July 1, 2010. Existing dischargers shall continue to implement their existing Monitoring Programs in compliance with State Water Board Order No. 99-08-DWQ until the necessary revisions are completed according to the schedule above.
- c. When a change of ownership occurs for all or any portion of the construction site prior to completion or final stabilization, the new discharger shall comply with these requirements as of the date the ownership change occurs.

2. Objectives

The CSMP shall be developed and implemented to address the following objectives:

- a. To demonstrate that the site is in compliance with the Discharge Prohibitions;

- b. To determine whether non-visible pollutants are present at the construction site and are causing or contributing to exceedances of water quality objectives;
 - c. To determine whether immediate corrective actions, additional Best Management Practice (BMP) implementation, or SWPPP revisions are necessary to reduce pollutants in storm water discharges and authorized non-storm water discharges; and
 - d. To determine whether BMPs included in the SWPPP are effective in preventing or reducing pollutants in storm water discharges and authorized non-storm water discharges.
- 3. Risk Level 1 - Visual Monitoring (Inspection) Requirements for Qualifying Rain Events**
- a. Risk Level 1 dischargers shall visually observe (inspect) storm water discharges at all discharge locations within two business days (48 hours) after each qualifying rain event.
 - b. Risk Level 1 dischargers shall visually observe (inspect) the discharge of stored or contained storm water that is derived from and discharged subsequent to a qualifying rain event producing precipitation of ½ inch or more at the time of discharge. Stored or contained storm water that will likely discharge after operating hours due to anticipated precipitation shall be observed prior to the discharge during operating hours.
 - c. Risk Level 1 dischargers shall conduct visual observations (inspections) during business hours only.
 - d. Risk Level 1 dischargers shall record the time, date and rain gauge reading of all qualifying rain events.
 - e. Within 2 business days (48 hours) prior to each qualifying rain event, Risk Level 1 dischargers shall visually observe (inspect):
 - i. All storm water drainage areas to identify any spills, leaks, or uncontrolled pollutant sources. If needed, the discharger shall implement appropriate corrective actions.
 - ii. All BMPs to identify whether they have been properly implemented in accordance with the SWPPP. If needed, the discharger shall implement appropriate corrective actions.

- iii. Any storm water storage and containment areas to detect leaks and ensure maintenance of adequate freeboard.
- f. For the visual observations (inspections) described in e.i and e.iii above, Risk Level 1 dischargers shall observe the presence or absence of floating and suspended materials, a sheen on the surface, discolorations, turbidity, odors, and source(s) of any observed pollutants.
- g. Within two business days (48 hours) after each qualifying rain event, Risk Level 1 dischargers shall conduct post rain event visual observations (inspections) to (1) identify whether BMPs were adequately designed, implemented, and effective, and (2) identify additional BMPs and revise the SWPPP accordingly.
- h. Risk Level 1 dischargers shall maintain on-site records of all visual observations (inspections), personnel performing the observations, observation dates, weather conditions, locations observed, and corrective actions taken in response to the observations.

4. Risk Level 1 – Visual Observation Exemptions

- a. Risk Level 1 dischargers shall be prepared to conduct visual observation (inspections) until the minimum requirements of Section I.3 above are completed. Risk Level 1 dischargers are not required to conduct visual observation (inspections) under the following conditions:
 - i. During dangerous weather conditions such as flooding and electrical storms.
 - ii. Outside of scheduled site business hours.
- b. If no required visual observations (inspections) are collected due to these exceptions, Risk Level 1 dischargers shall include an explanation in their SWPPP and in the Annual Report documenting why the visual observations (inspections) were not conducted.

5. Risk Level 1 – Monitoring Methods

Risk Level 1 dischargers shall include a description of the visual observation locations, visual observation procedures, and visual observation follow-up and tracking procedures in the CSMP.

6. Risk Level 1 – Non-Storm Water Discharge Monitoring Requirements

- a. Visual Monitoring Requirements:
- i. Risk Level 1 dischargers shall visually observe (inspect) each drainage area for the presence of (or indications of prior) unauthorized and authorized non-storm water discharges and their sources.
 - ii. Risk Level 1 dischargers shall conduct one visual observation (inspection) quarterly in each of the following periods: January-March, April-June, July-September, and October-December. Visual observation (inspections) are only required during daylight hours (sunrise to sunset).
 - iii. Risk Level 1 dischargers shall ensure that visual observations (inspections) document the presence or evidence of any non-storm water discharge (authorized or unauthorized), pollutant characteristics (floating and suspended material, sheen, discoloration, turbidity, odor, etc.), and source. Risk Level 1 dischargers shall maintain on-site records indicating the personnel performing the visual observation (inspections), the dates and approximate time each drainage area and non-storm water discharge was observed, and the response taken to eliminate unauthorized non-storm water discharges and to reduce or prevent pollutants from contacting non-storm water discharges.

7. Risk Level 1 – Non-Visible Pollutant Monitoring Requirements

- a. Risk Level 1 dischargers shall collect one or more samples during any breach, malfunction, leakage, or spill observed during a visual inspection which could result in the discharge of pollutants to surface waters that would not be visually detectable in storm water.
- b. Risk Level 1 dischargers shall ensure that water samples are large enough to characterize the site conditions.
- c. Risk Level 1 dischargers shall collect samples at all discharge locations that can be safely accessed.
- d. Risk Level 1 dischargers shall collect samples during the first two hours of discharge from rain events that occur during business hours and which generate runoff.
- e. Risk Level 1 dischargers shall analyze samples for all non-visible pollutant parameters (if applicable) - parameters indicating the

presence of pollutants identified in the pollutant source assessment required (Risk Level 1 dischargers shall modify their CSMPs to address these additional parameters in accordance with any updated SWPPP pollutant source assessment).

- f. Risk Level 1 dischargers shall collect a sample of storm water that has not come in contact with the disturbed soil or the materials stored or used on-site (uncontaminated sample) for comparison with the discharge sample.
- g. Risk Level 1 dischargers shall compare the uncontaminated sample to the samples of discharge using field analysis or through laboratory analysis.²
- h. Risk Level 1 dischargers shall keep all field /or analytical data in the SWPPP document.

8. Risk Level 1 – Particle Size Analysis for Project Risk Justification

Risk Level 1 dischargers justifying an alternative project risk shall report a soil particle size analysis used to determine the RUSLE K-Factor. ASTM D-422 (Standard Test Method for Particle-Size Analysis of Soils), as revised, shall be used to determine the percentages of sand, very fine sand, silt, and clay on the site.

9. Risk Level 1 – Records

Risk Level 1 dischargers shall retain records of all storm water monitoring information and copies of all reports (including Annual Reports) for a period of at least three years. Risk Level 1 dischargers shall retain all records on-site while construction is ongoing. These records include:

- a. The date, place, time of facility inspections, sampling, visual observation (inspections), and/or measurements, including precipitation.
- b. The individual(s) who performed the facility inspections, sampling, visual observation (inspections), and or measurements.
- c. The date and approximate time of analyses.
- d. The individual(s) who performed the analyses.

² For laboratory analysis, all sampling, sample preservation, and analyses must be conducted according to test procedures under 40 CFR Part 136. Field discharge samples shall be collected and analyzed according to the specifications of the manufacturer of the sampling devices employed.

- e. A summary of all analytical results from the last three years, the method detection limits and reporting units, and the analytical techniques or methods used.
- f. Rain gauge readings from site inspections.
- g. Quality assurance/quality control records and results.
- h. Non-storm water discharge inspections and visual observation (inspections) and storm water discharge visual observation records (see Sections I.3 and I.6 above).
- i. Visual observation and sample collection exception records (see Section I.4 above).
- j. The records of any corrective actions and follow-up activities that resulted from analytical results, visual observation (inspections), or inspections.

REFERENCE DRAWINGS

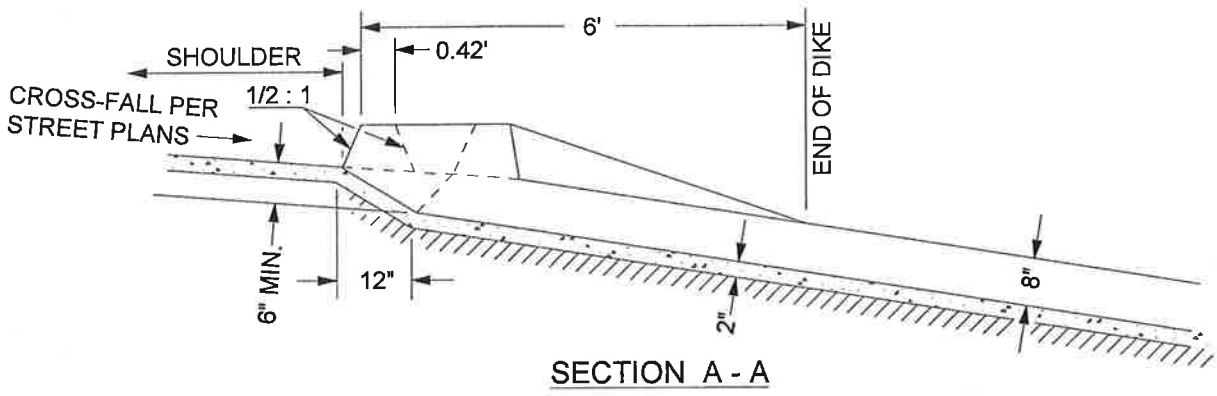

SECTION A - A

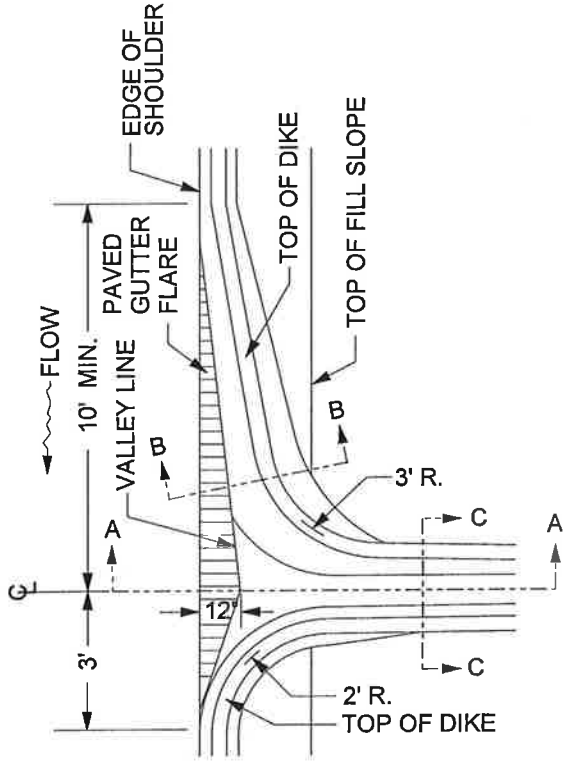

PLAN

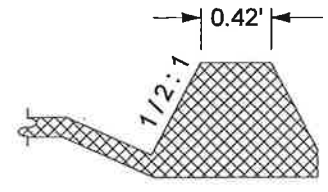

SECTION B - B

NOTE:
CROSS - SECTION OF SLOPE DITCH MAY BE SEMICIRCULAR, VEE, OR TRAPEZOIDAL. MIN. TOP WIDTH = 25", MIN. DEPTH = 8".

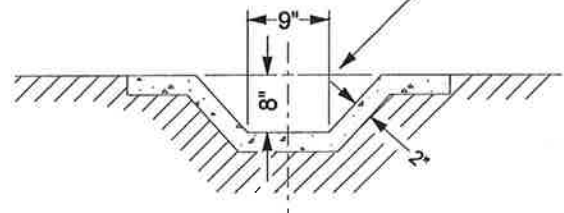

SECTION C - C

TO BE USED ON FILL SLOPES FLATTER THAN 4 : 1. USE MIN. 10' LENGTH OF GUTTER ON BOTH SIDES IN A SAG LOCATION. USE PIPE DOWNDRAINS FOR SLOPES STEEPER THAN 4 : 1 SLOPES.

NOT TO SCALE

APPROVED BY:

George A. Johnson
DIRECTOR OF TRANSPORTATION
GEORGE A. JOHNSON, RCE 42328

DATE: 05/01/07



COUNTY OF RIVERSIDE

**ASPHALT CONCRETE
OVERSIDE DRAIN**

REVISIONS	REV.	BY:	APR'D	DATE	REV.	BY:	APR'D	DATE
8-18-77, 2-82	1				4			
11-04	2				5			
	3				6			

STANDARD NO. 306

DIST.	COUNTY	ROUTE	SHEET TITLE	SHEET NO.
			TOTAL PROJECT	NO. SHEETS

May 1, 2006 REGISTERED CIVIL ENGINEER Chad Capelton REGISTERED CIVIL ENGINEER

The State of California, State Board of Professional Engineers and Land Surveyors, hereby certifies that the undersigned is a duly licensed and qualified professional engineer in the State of California, and is authorized to practice in the State of California.

To get the California web site, go to: <http://www602.ca.gov>

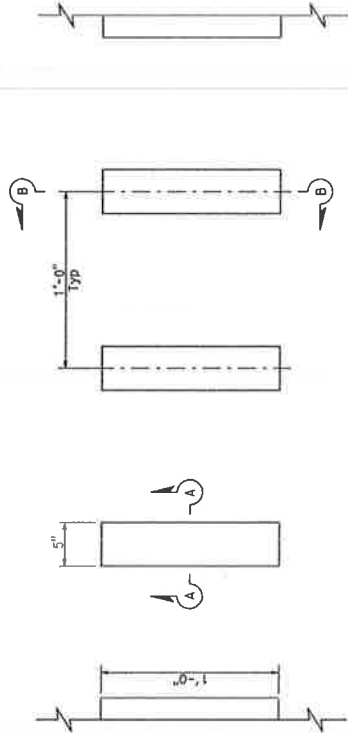

PLAN
GROUND-IN INDENTATIONS

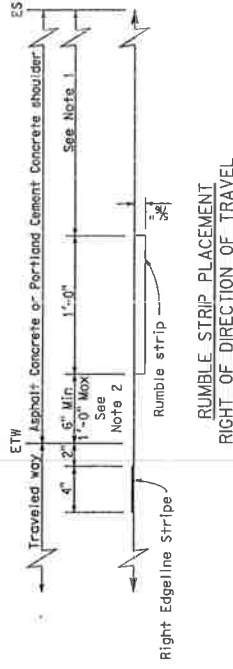
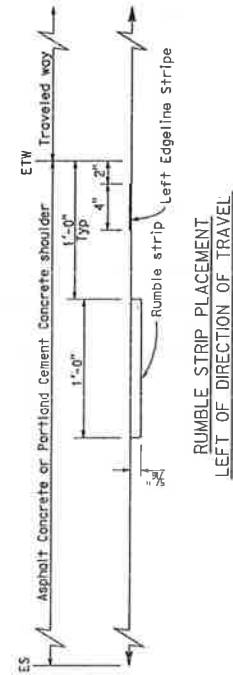

TYPICAL GROUND-IN RUMBLE STRIP
SHOULDER PLACEMENT

STATE OF CALIFORNIA
DEPARTMENT OF TRANSPORTATION

SHOULDER RUMBLE STRIP
DETAILS
GROUND-IN INDENTATIONS

NO SCALE

A 40B

NOTES:

- Where bicycles are permitted, shoulder rumble strips should not be used right of direction of travel, unless a minimum of 6" offset from the edge of the shoulder is available between the rumble strip and the outer edge of the shoulder. Where bicycles are not permitted, a minimum of 4'-0" of distance is required between the rumble strip and the outer edge of the shoulder.
- Unless otherwise shown on the plans or specified in the special provisions, the 6" offset from the edge of traveled way to the edge of the rumble strip shall be used for rumble strip placement right of the direction of travel.

DIST COUNTY ROUTE FOOT MILES SHEET TOTAL
 TOTAL PROJECT NO. SHEETS
 REGISTERED CIVIL ENGINEER
 May 1, 2006
 PLANS APPROVAL DATE
 THE STATE OF CALIFORNIA or its OFFICERS or
 AGENTS shall not be liable for any errors or
 omissions in these plans or for any consequences
 arising therefrom, except to the extent that they
 are caused by negligence.
 To get to the Collins web site, go to: <http://www.dagdy.com>

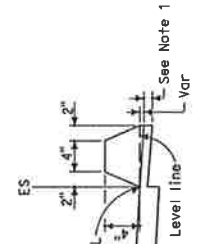

TYPE A
See Note 3

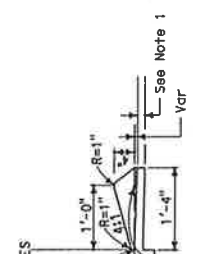

TYPE C

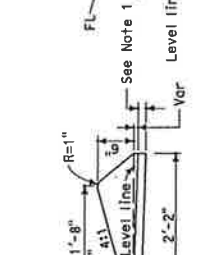

TYPE D

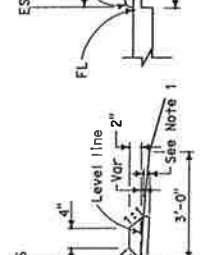

TYPE E

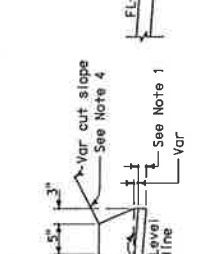

TYPE F
See Note 5

DIKES

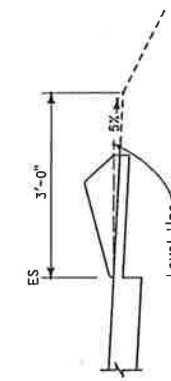

CASE R
See Note 2

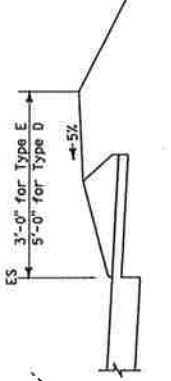

CASE E

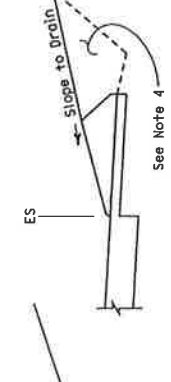

CASE C-2
Cut Slope

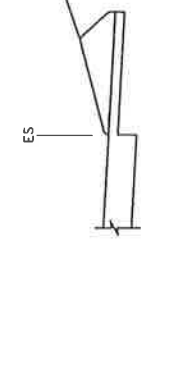

CASE C-1
Cut Slope

TYPE D AND E BACKFILL DETAILS

DIKE QUANTITIES

TYPE	CUBIC YARDS PER LINEAR FOOT
A	0.0135
C	0.0038
D	0.0293
E	0.0130
F	0.0066

Quantities based on 5% cross slope.

- NOTES:**
1. For AC shoulders only, extend top layer of AC placed on the shoulder under dike with no joint at the ES.
 2. Case R applies to retrofit only projects where restrictive conditions do not provide enough width for Case F backfill.
 3. Type A dike only to be used where restrictive slope conditions do not provide enough width to use Type D or Type E dike.
 4. Fill and compact with excavated material to top of dike.
 5. Use Type F dike, where dike is required with guard railing installations. See Standard Plan A764 for dike positioning details.

Typical CA Type L Object Marker

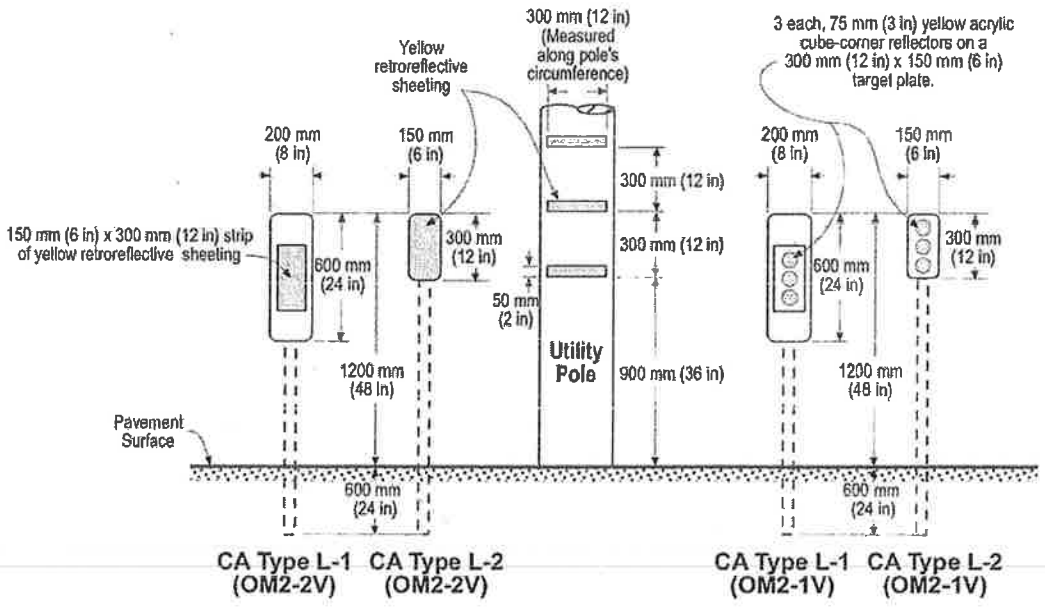



OFFICE OF
CLERK OF THE BOARD OF SUPERVISORS
1st FLOOR, COUNTY ADMINISTRATIVE CENTER
P.O. BOX 1147, 4080 LEMON STREET
RIVERSIDE, CA 92502-1147
PHONE: (951) 955-1060
FAX: (951) 955-1071

KECIA HARPER-IHEM
Clerk of the Board of Supervisors

KIMBERLY A. RECTOR
Assistant Clerk of the Board

March 17, 2011

THE PRESS ENTERPRISE
ATTN: LEGALS
PO BOX 792
RIVERSIDE, CA 92501

FAX (951) 368-9018
E-MAIL: legals@pe.com

RE: NOTICE INVITING BIDS: EL SOBRANTE ROAD B8-0620

To Whom It May Concern:

Attached is a copy for publication in your newspaper for **TEN (10) TIMES:**

Sunday	- March 20, 2011	Friday	- March 25, 2011
Monday	- March 21, 2011	Saturday	- March 26, 2011
Tuesday	- March 22, 2011	Sunday	- March 27, 2011
Wednesday	- March 23, 2011	Monday	- March 28, 2011
Thursday	- March 24, 2011	Tuesday	- March 29, 2011

We require your affidavit of publication immediately upon completion of the last publication.

Your invoice must be submitted to this office in duplicate, WITH TWO CLIPPINGS OF THE PUBLICATION.

NOTE: PLEASE COMPOSE THIS PUBLICATION INTO A SINGLE COLUMN FORMAT.

Thank you in advance for your assistance and expertise.

Sincerely,

McGil

Cecilia Gil, Board Assistant to
KECIA HARPER-IHEM, CLERK OF THE BOARD

Gil, Cecilia

From: PE Legals [legals@pe.com]
Sent: Thursday, March 17, 2011 8:24 AM
To: Gil, Cecilia
Subject: RE: FOR PUBLICATION: Notice Inviting Bids

Received for publication on March 20 ~~and~~ ^{to} 29

Thank You!

enterprise media

Publisher of the Press-Enterprise

Maria G. Tinajero • Legal Advertising Department

1-800-880-0345 • Fax: 951-368-9018 • email: legals@pe.com

Please Note: Deadline is 10:30 AM two (2) business days prior to the date you would like to publish.
Additional days required for larger ad sizes

From: Gil, Cecilia [<mailto:CCGIL@rcbos.org>]
Sent: Thursday, March 17, 2011 8:13 AM
To: PE Legals
Subject: FOR PUBLICATION: Notice Inviting Bids

Good Morning! Attached is a Notice Inviting Bids, for publication from March 20, 2011 to March 29, 2011. Please confirm. THANK YOU!

Cecilia Gil

Board Assistant to the
Clerk of the Board of Supervisors
951-955-8464

**THE COUNTY ADMINISTRATIVE CENTER IS CLOSED EVERY FRIDAY UNTIL FURTHER NOTICE.
PLEASE CONSIDER THE ENVIRONMENT BEFORE PRINTING.**

NOTICE INVITING BIDS

Sealed proposals will be received at the Riverside County Transportation Department, 14th Street Transportation Annex, 3525 14th Street, Riverside, California 92501, telephone (951) 955-6780 until 2:00 pm on Wednesday, April 6, 2011 at which time they will be publicly opened at said address, for construction in accordance with the specifications therefore, to which special reference is made, as follows:
County of Riverside,

**EL SOBRANTE ROAD
SAFETY PROJECT
SHOULDER WIDENING AND STRIPING
FROM LA SIERRA AVENUE TO CAJALCO ROAD**

**PROJECT No. B8-0620
FEDERAL AID NO. HRRRL – 5956 (182)**

The UDBE Contract goal is 1.2 percent.

A pre-bid meeting is scheduled for 2:15 pm on Wednesday, March 30, 2011, at the County of Riverside Transportation Department, 3525 14th Street, Riverside, California 92501. This meeting is to inform bidders of project requirements and subcontractors of subcontracting and material supply opportunities. Bidder's attendance at this meeting is not mandatory.

THIS PROJECT IS SUBJECT TO THE "BUY AMERICA" PROVISIONS OF THE SURFACE TRANSPORTATION ASSISTANCE ACT OF 1982 AS AMENDED BY THE INTERMODAL SURFACE TRANSPORTATION EFFICIENCY ACT OF 1991.

Bids are required for the entire work described herein. The Contractor shall possess a current and active State of California Class "A" Contractor's license or C-12 license at the time this contract is awarded. The successful bidder shall furnish a payment bond and a performance bond.

This contract is subject to state contract nondiscrimination and compliance requirements pursuant to Government Code, Section 12990.

Inquiries or questions based on alleged patent ambiguity of the plans, specifications or estimate must be communicated as a bidder inquiry, in writing, prior to bid opening. Any such inquiries or questions, submitted after bid opening, will not be treated as a bid protest. Technical questions should be directed to the office of the County of Riverside Transportation Department, 3525 14th Street, Riverside, CA 92501, telephone (951) 955-6780, electronic mail: jrjimenez@rctlma.org.

Plans and specifications may be obtained for a NONREFUNDABLE FEE OF \$30 PER SET, and are available at 3525 14th Street, Riverside, CA 92501.

Engineer Estimate	\$630,000 - \$810,000
Bid Bond	10%
Performance Bond	100%
Payment Bond	100%
Working Days	30 (Calendar Days)

Dated: March 17, 2011

Kecia Harper-Ihem, Clerk of the Board
By: Cecilia Gil, Board Assistant



THE PRESS-ENTERPRISE PT.com

THE BUSINESS PRESS SoCal

LA PRENSA WEEKLY



Legal Advertising Invoice

① BILLING PERIOD | ② ADVERTISING/CLIENT NAME
 03/29/11 - 03/29/11 | BOARD OF SUPERVISORS

③ BILLING DATE | | FOR BILLING INFORMATION CALL | ④ PAGE NO
 03/29/11 | (951) 368-9713 | 1

⑤ TOTAL AMOUNT DUE | * UNAPPLIED AMOUNT | ⑥ TERMS OF PAYMENT
 1,754.50 | | Due Upon Receipt

⑦ REMITTANCE ADDRESS
 POST OFFICE BOX 12009
 RIVERSIDE, CA 92502-2209

⑧ BILLED ACCOUNT NAME AND ADDRESS
 BOARD OF SUPERVISORS
 COUNTY OF RIVERSIDE
 P.O. BOX 1147
 RIVERSIDE CA 92502

⑨ BILLED ACCOUNT NUMBER | ⑩ REP NO
 045202 | LE04

Statement #: 56588325 Amount Paid \$ _____ Your Check # _____

PLEASE DETACH AND RETURN UPPER PORTION WITH YOUR REMITTANCE

⑬ DATE	⑪ REFERENCE	⑫ ⑬ ⑭ DESCRIPTION-OTHER COMMENTS/CHARGES	⑮ SAU SIZE ⑯ BILLED UNITS	⑰ RATE	⑱ GROSS AMOUNT	⑳ NET AMOUNT
03/20	4282536 CO	NIB-EL SOBRANTE RD PROJ NO B8- Class : 10 Ctext Ad# 10590077 Placed By : Cecilia Gil	145 L	1.30		188.50
03/21	4282536 CO	NIB-EL SOBRANTE RD PROJ NO B8- Class : 10 Ctext Ad# 10590077 Placed By : Cecilia Gil	145 L	1.20		174.00
03/22	4282536 CO	NIB-EL SOBRANTE RD PROJ NO B8- Class : 10 Ctext Ad# 10590077 Placed By : Cecilia Gil	145 L	1.20		174.00
03/23	4282536 CO	NIB-EL SOBRANTE RD PROJ NO B8- Class : 10 Ctext Ad# 10590077 Placed By : Cecilia Gil	145 L	1.20		174.00
03/24	4282536 CO	NIB-EL SOBRANTE RD PROJ NO B8- Class : 10 Ctext Ad# 10590077 Placed By : Cecilia Gil	145 L	1.20		174.00
03/25	4282536 CO	NIB-EL SOBRANTE RD PROJ NO B8- Class : 10 Ctext Ad# 10590077 Placed By : Cecilia Gil	145 L	1.20		174.00
03/26	4282536 CO	NIB-EL SOBRANTE RD PROJ NO B8- Class : 10 Ctext Ad# 10590077 Placed By : Cecilia Gil	145 L	1.20		174.00
03/27	4282536 CO	NIB-EL SOBRANTE RD PROJ NO B8- Class : 10 Ctext Ad# 10590077 Placed By : Cecilia Gil	145 L	1.20		174.00
03/28	4282536 CO	NIB-EL SOBRANTE RD PROJ NO B8- Class : 10 Ctext Ad# 10590077 Placed By : Cecilia Gil	145 L	1.20		174.00
03/29	4282536 CO	NIB-EL SOBRANTE RD PROJ NO B8- Class : 10 Ctext Ad# 10590077 Placed By : Cecilia Gil	145 L	1.20		174.00

*Transp.
3.50 of 03/15/11
1 hr*

RECEIVED BY THE BOARD OF SUPERVISORS
 2011 APR -4 PM 3:09

②① *CURRENT NET AMOUNT DUE	②② 30 DAYS	②③ 60 DAYS	②④ OVER 90 DAYS	②⑤ * UNAPPLIED AMOUNT	②⑥ PLEASE PAY THIS AMOUNT
					1,754.50

enterprise media P.O. BOX 12009
 THE PRESS-ENTERPRISE PT.com RIVERSIDE, CA 92502-2209
 FAX (951) 368-9026

ADVERTISING
 STATEMENT/INVOICE

* UNAPPLIED AMOUNTS ARE INCLUDED IN TOTAL AMOUNT DUE



②⑦ STATEMENT NUMBER	②⑧ BILLING PERIOD	②⑨ BILLED ACCOUNT NUMBER	②⑩ ADVERTISER/CLIENT NUMBER	②⑪ ADVERTISER/CLIENT NAME
56588325	03/29/11 - 03/29/11	045202		BOARD OF SUPERVISORS

THE PRESS-ENTERPRISE

3450 Fourteenth Street
Riverside CA 92501-3878
951-684-1200
951-368-9018 FAX

**PROOF OF PUBLICATION
(2010, 2015.5 C.C.P.)**

Press-Enterprise

PROOF OF PUBLICATION OF

Ad Desc.: NIB-El Sobrante Rd proj no B8-0620

I am a citizen of the United States. I am over the age of eighteen years and not a party to or interested in the above entitled matter. I am an authorized representative of THE PRESS-ENTERPRISE, a newspaper of general circulation, printed and published daily in the County of Riverside, and which newspaper has been adjudicated a newspaper of general circulation by the Superior Court of the County of Riverside, State of California, under date of April 25, 1952, Case Number 54446, under date of March 29, 1957, Case Number 65673 and under date of August 25, 1995, Case Number 267864; that the notice, of which the annexed is a printed copy, has been published in said newspaper in accordance with the instructions of the person(s) requesting publication, and not in any supplement thereof on the following dates, to wit:

03-20-11
03-21-11
03-22-11
03-23-11
03-24-11
03-25-11
03-26-11
03-27-11
03-28-11
03-29-11

I Certify (or declare) under penalty of perjury that the foregoing is true and correct.

Date: Mar. 29, 2011
At: Riverside, California



BOARD OF SUPERVISORS

P.O. BOX 1147
COUNTY OF RIVERSIDE
RIVERSIDE CA 92502

Ad #: 10590077

PO #:

Agency #: _____

Ad Copy:

NOTICE INVITING BIDS

Sealed proposals will be received at the Riverside County Transportation Department, 14th Street Transportation Annex, 3525 14th Street, Riverside, California 92501, telephone (951) 955-6780 until 2:00 pm on Wednesday, April 6, 2011 at which time they will be publicly opened at said address, for construction in accordance with the specifications therefore, to which special reference is made, as follows:
County of Riverside,

**EL SOBRANTE ROAD
SAFETY PROJECT
SHOULDER WIDENING AND STRIPING
FROM LA SIERRA AVENUE TO CAJALCO ROAD
PROJECT No. B8-0620
FEDERAL AID NO. HRRRL - 5956 (182)**

The UDBE Contract goal is 1.2 percent.

A pre-bid meeting is scheduled for 2:15 pm on Wednesday, March 30, 2011, at the County of Riverside Transportation Department, 3525 14th Street, Riverside, California 92501. This meeting is to inform bidders of project requirements and subcontractors of subcontracting and material supply opportunities. Bidder's attendance at this meeting is not mandatory.

THIS PROJECT IS SUBJECT TO THE "BUY AMERICA" PROVISIONS OF THE SURFACE TRANSPORTATION ASSISTANCE ACT OF 1982 AS AMENDED BY THE INTERMODAL SURFACE TRANSPORTATION EFFICIENCY ACT OF 1991.

Bids are required for the entire work described herein. The Contractor shall possess a current and active State of California Class "A" Contractor's license or C-12 license at the time this contract is awarded. The successful bidder shall furnish a payment bond and a performance bond.

This contract is subject to state contract nondiscrimination and compliance requirements pursuant to Government Code, Section 12990.

Inquiries or questions based on alleged patent ambiguity of the plans, specifications or estimate must be communicated as a bidder inquiry, in writing, prior to bid opening. Any such inquiries or questions, submitted after bid opening, will not be treated as a bid protest. Technical questions should be directed to the office of the County of Riverside Transportation Department, 3525 14th Street, Riverside, CA 92501, telephone (951) 955-6780, electronic mail: rjimenez@rctlma.org.

Plans and specifications may be obtained for a NON-REFUNDABLE FEE OF \$30 PER SET, and are available at 3525 14th Street, Riverside, CA 92501.

Engineer Estimate	\$630,000 - \$810,000
Bid Bond	10%
Performance Bond	100%
Payment Bond	100%
Working Days	30 (Calendar Days)

Dated: March 17, 2011
Kecia Harper-Ihem,
Clerk of the Board
By: Cecilia Gil,
Board Assistant

3/20, 21, 22, 23, 24, 25, 26, 27, 28, 29

RECEIVED RIVERSIDE COUNTY
LEAK/DRAINAGE SUPERVISORS
2011 APR -4 PM 3:09