



REDEVELOPMENT AGENCY FOR THE COUNTY OF RIVERSIDE
CONTRACT DOCUMENTS FOR THE
RUBIDOUX AREA II STREET AND STORM DRAIN IMPROVEMENT PROJECT

ADDENDUM No. 4

Please Be Advised: the Agency hereby updates the following sections of the plans and specifications:

1. Reference: Construction Specifications, Section I Bidding Requirements, Contractor's Proposal:

A. The Contractor's Proposal has been updated in its entirety to reflect the updated field survey plans. There are now 110 items to bid on.

2. ADD Items 104 through 110 as follows:

104. Payment for "Hot Tap and connect to Existing 6" ACP Waterline" will be made on a per each (EA.) basis as specified in the bid schedule, which shall include all cost for labor, materials, equipment, permits/authorization and performing all work required to Hot Tap existing waterline, install gate valve, install cut-in valve, disinfect and connect to new waterlines, cut-off, plug and abandon existing waterline as required, install thrust blocks and legally dispose of removed materials, in accordance with plans and specifications.

105. Payment for "Hot Tap and connect to Existing 8" DIP Waterline" will be made on a per each (EA.) basis as specified in the bid schedule, which shall include all cost for labor, materials, equipment, permits/authorization and performing all work required to Hot Tap existing waterline, install gate valve, install cut-in valve, disinfect and connect to new waterline, cut-off, plug and abandon existing waterline as required, install thrust blocks and legally dispose of removed materials, in accordance with plans and specifications.

106. Payment for "Hot Tap and connect to Existing 12" PVC Waterline" will be made on a per each (EA.) basis as specified in the bid schedule, which shall include all cost for labor, materials, equipment, permits/authorization and performing all work required to Hot Tap existing waterline, install gate valve, install cut-in valve, disinfect and connect to new waterline, cut-off, plug and abandon existing waterline as required, install thrust blocks and legally dispose of removed materials, in accordance with plans and specifications.

107. Payment for "Encase Existing 6" A.C.P Waterline" will be made on a per lineal foot basis (L.F.), which shall include all cost for labor, materials, equipment, permit/authorization, and performing all work required to excavate, encase existing waterline and backfill to bottom of sub-grade of the final road surface elevation, in accordance with plans and specifications.
108. Payment for "Encase Existing 8" D.I.P Waterline" will be made on a per lineal foot basis (L.F.), which shall include all cost for labor, materials, equipment, permit/authorization, and performing all work required to excavate, encase existing waterline and backfill to bottom of sub-grade of the final road surface elevation, in accordance with plans and specifications.
109. Payment for "Encase Existing 12" P.V.C. Waterline" will be made on a per lineal foot basis (L.F.), which shall include all cost for labor, materials, equipment, permit/authorization, and performing all work required to excavate, encase existing waterline and backfill to bottom of sub-grade of the final road surface elevation, in accordance with plans and specifications.
110. Payment for "Connect Existing Water Meter to New Water Main" will be made on a per each (EA.) basis as specified in the bid schedule, which shall include all cost for labor, materials, equipment, permits/authorization and performing all work required to install water meter service connection and piping per R.C.S.D. standard drawing W1090 and W1100. Payment for relocation of water meter, meter box and customer service piping shall be per Bid Item No. 42.

3. **Reference:** Construction Specifications, Technical Provisions, Article 33 Concrete Curb, Gutter, Cross Gutter, Spandrel, Driveway Approaches, Sidewalk and Curb Ramps, Page TP-29 and **Addendum No.3 Item No. 21**

Delete reference to Section 51 of the Standard Specifications in the first paragraph.

Delete the entire second paragraph and the entire third paragraph as modified by Addendum No.3

For clarification note that all removals, excavation and grading within the limits of the roadway between existing or proposed rights-of-way shall be performed under Bid Item No. 9 "Roadway Excavation".

4. **Reference:** Construction Specifications, Technical Provisions.

ADD the following Technical Provision:

ARTICLE 36 WATERLINE ENCASEMENT

Contractor shall encase existing waterlines in accordance with the "Waterline Encasement Detail, Figure 1 Addendum No.4".

Contractor shall encase all waterlines found to have less than 3.5' of cover as measured from the final top of pavement elevation to the top of the existing waterline. Waterlines found to have less than or equal to 2.5' of cover will require to be relocated in accordance with plans and specifications.

Contractor shall backfill encasement excavation with 2-sack sand/cement slurry to bottom of subgrade of the final road surface elevation.

5. **Reference:** Construction Specifications, Technical Provisions.

ADD the following Technical Provision;

ARTICLE 37 WATERLINE RELOCATION SPECIFICATIONS

In order to determine the limits of waterlines to be relocated Contractor shall pothole existing waterline as directed by owner and witnessed by Owner's representative. Thereafter Owner will require a minimum of 15 working days to determine limits of waterline relocation after receipt of pothole data from Contractor.

Once the limits of waterline relocation are determined, Contractor shall provide notice to Rubidoux Community Service District (R.C.S.D.) a minimum of 10 working days in advance of commencement of waterline relocation. Contractor shall be responsible for proper homeowner notification if residential water service is to be interrupted.

Contractor shall furnish and install for each waterline relocation two (2) hot tapped valves, two (2) cut-in valves, new piping, and thrust blocks per "Waterline relocation Detail, Figure 2" (Addendum No.4) and in accordance with R.C.S.D. Standards and Specifications unless approved otherwise.

Contractor shall test and disinfect all new waterline installations, providing all test plates, fitting and equipment as required. All work shall be done in accordance with R.C.S.D. Standards and Specifications

Asbestos Cement Pipe is to be handled in accordance will all applicable California State laws and regulations and legally disposed of at a landfill permitted for disposal of asbestos containing materials.

If determined, the Agency shall address any further clarifications within subsequent Addendums.

By: E.S.
Erik Sydow
Project Manager

Date: 6/1/11

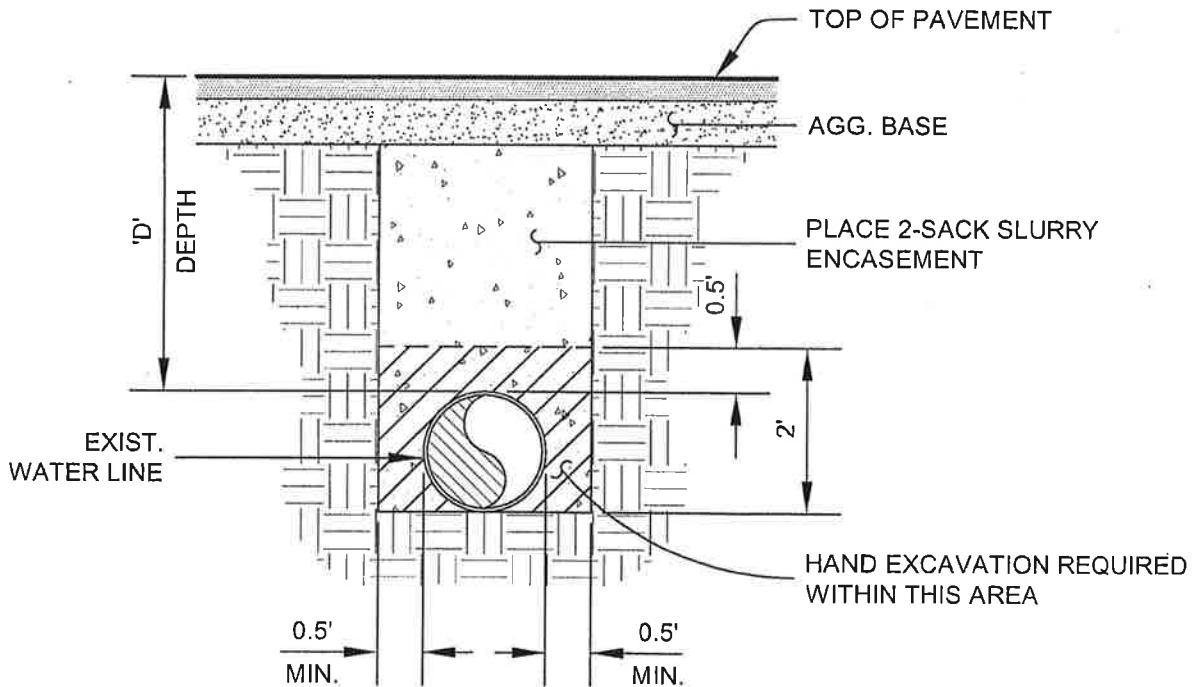

WATERLINE ENCASEMENT DETAIL

NTS

- $D \leq 2.5'$ LOWER WATERLINE AND ENCASE TO 3.5' MIN. COVER PER R.C.S.D. STDS. AND TECHNICAL PROVISION ARTICLE 37.
- $2.5' < D < 3.5'$ EXCAVATE AND ENCASE PER DETAIL HEREON.
- $3.5' \leq D$ NO ENCASEMENT REQUIRED. BACKFILL PER R.C.S.D. STD. DWG. G20.

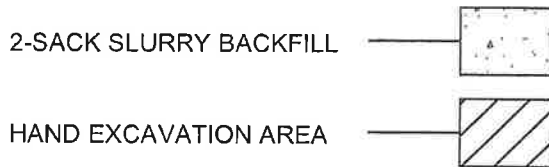

	ADDENDUM # 4	FIGURE
	COUNTY OF RIVERSIDE RUBIDOUX AREA 2 WATERLINE ENCASEMENT DETAIL	1
SCALE: N.T.S. DATE: 05/27/11	ECONOMIC DEVELOPMENT AGENCY OF RIVERSIDE COUNTY	OF 2

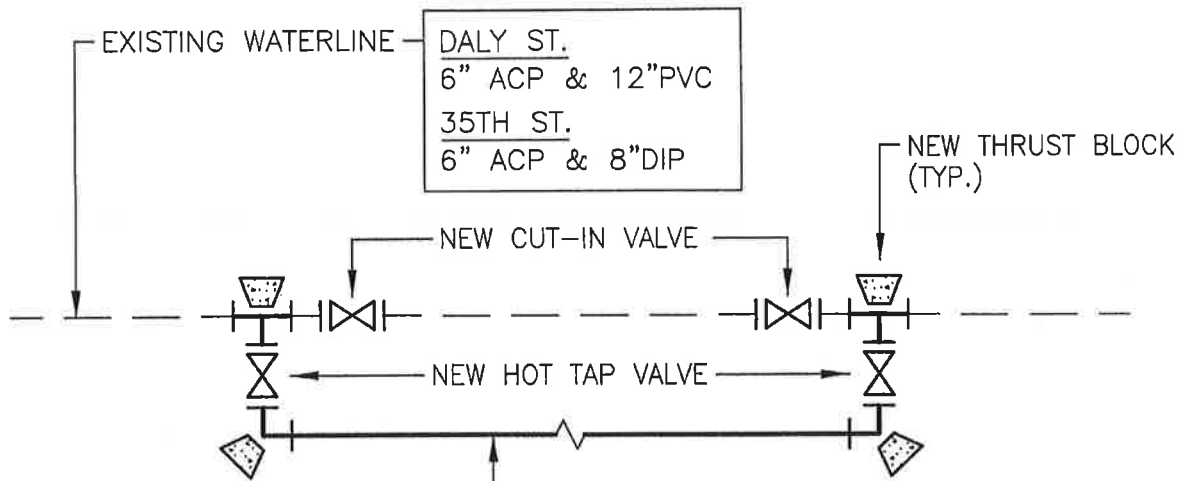

NEW WATERLINE

DALY ST.

400± L.F. 6" CLASS 350 CML/DI PIPE & FITTINGS

250± L.F. 12" C900 CLASS 200 PVC PIPE & DIP FITTINGS

35TH ST.

250± L.F. 6" CLASS 350 CML/DI PIPE & FITTINGS

75± L.F. 8" CLASS 350 CML/DI PIPE & FITTINGS

WATERLINE RELOCATION DETAIL

NTS

GENERAL CONSTRUCTION SEQUENCE

1. INSTALL HOT TAP VALVES AND CUT-IN VALVES.
2. CONSTRUCT BYPASS PIPING AND CONNECT TO HOT TAP VALVES WITH TEST PLATES.
3. TEST AND DISINFECT BYPASS PIPING.
4. REMOVE TEST PLATES AND CLOSE CUT-IN VALVES.

	ADDENDUM # 4	FIGURE
	COUNTY OF RIVERSIDE RUBIDOUX AREA 2 WATERLINE RELOCATION DETAIL	2
SCALE: N.T.S. DATE: 05/31/11	ECONOMIC DEVELOPMENT AGENCY OF RIVERSIDE COUNTY	



**REDEVELOPMENT AGENCY FOR THE COUNTY OF RIVERSIDE
CONTRACT DOCUMENTS FOR THE
RUBIDOUX AREA II STREET AND STORM DRAIN IMPROVEMENT PROJECT**

ADDENDUM No. 3

Please Be Advised: the Agency hereby updates the following sections of the plans and specifications:

1. Reference: Construction Specifications, Notice Inviting Bids, Page BD-1:
 - a. Proposals shall hereby be delivered to the Clerk of the Board of Directors, on the 1st floor of the County Administrative Center located at 4080 Lemon Street, 1st Floor, Riverside, CA 92501, no later than 2:00 p.m., on June 6, 2011 to be promptly opened in public at said address.
2. Soils Report: The Draft Soils Report, Project No. 110055, from Heider Engineering has been executed and finalized; recommendations and conclusion observations have not changed, so the Agency will not reissue the final until construction. Contractor shall base costs on the soil report conclusions and recommendations.
3. **Delete Plans:** Contractor will not be responsible for bidding any items associated with the Claystone Avenue, Canyon Pines Place Sidewalk Project (2 Sheets).
4. **Add Plans:** Contractor shall be responsible for the storm drain improvements identified within the Rubidoux – Crestmore Road Storm Drain Improvement Plans (8 sheets).
5. **Reference:** Construction Specifications, General Conditions, Article 1 General Provisions, 1.1 - Definitions, Page GC-1:

Add the following definitions:

Rubidoux Community Services District, hereinafter RCSD, is the water, fire-water, and sewer purveyor for the Community of Rubidoux. RCSD specifications and standards can be found at RCSD's website, <http://www.rcsd.org/development-resources.asp>, known as the "Water and Sanitary Sewer Design & Construction Manual (2005 version)."

Riverside County Flood Control District, hereinafter RCFC, is the regional drainage authority for the County of Riverside. RCFC specifications and standards can be found at RCFC's website, <http://www.floodcontrol.co.riverside.ca.us/DistrictDocuments.aspx>.

Riverside County Transportation Department, hereinafter RCTD, is responsible for planning, designing, funding, building, operating and maintaining all roads, bridges, and transportation facilities within the unincorporated County territory. RCTD specifications and standards can be found at RCTD's website, http://www.rctlma.org/trans/land_dev_ord_461.html.

6. **Reference:** Construction Specifications, Bidding Documents, Contractor's Proposal, Item 31.
 - a. Contractor can assume a 4" drain.
7. **Reference:** Construction Specifications, Bidding Documents, Contractor's Proposal, Item 38.
 - a. Item 38 is in relation to a 3'x3' water vault.
8. **Reference:** Construction Specifications, Bidding Documents, Contractor's Proposal, Item 71.
 - a. Addendum Number 2 stated "Construct 3'x4' RCB per Caltrans Standard D-80", and will be **Replaced** with "Construct 3'x5' RCB per Caltrans Standard D-80"
9. **Reference:** Construction Specifications, Bidding Documents, Payment for Items, Pages BD-11 through BD-19:
 - a. **Replace** Item 1 with the following:
 1. Payment for **"Mobilization"** will be made on a lump sum (L.S.) basis, as specified in the bid schedule, which shall include all costs for labor, materials, equipment, permits/authorization required to establish a construction staging area(s), and placing a construction trailer and equipment in accordance with the specifications. Mobilization shall also include contract bonds, project insurance, demobilization, and project management.
 - b. **Delete** Item 3 in its entirety.
 - c. **Delete** Item 6 in its entirety.
 - d. **Replace** Item 10 with the following:
 10. Payment for **"Place AC Pavement"** will be made on a per ton (TON) basis, as specified in the bid schedule, which shall include all costs for labor, materials, equipment, permits/authorization, and performing all work required to provide and place AC pavement for course thickness as shown on Standard Improvement Plan Sheet 2, in accordance with the plans and specifications.

- e. **Revise** basis for payment in Item 15 to read "will be made on a per square foot (S.F.) basis".
- f. **Replace** Item 20 with the following:
 - 20. Payment for **"Cold Plane 0.1' Existing Pavement"** will be made on a per square foot (S.F.) basis, as specified in the bid schedule, which shall include all costs for labor, materials, equipment, permits/authorization, and performing all work required to cold plane surface of existing pavement and legally dispose of removed material, in accordance with the plans and specifications.
- g. **Replace** Item 22 with the following:
 - 22. Payment for **"Construct Cross Gutter, Spandrel, and Curb Return"** will be made on a per square foot (S.F.) basis, as specified in the bid schedule, which shall include all costs for labor, materials, equipment, permits/authorization, and performing all work required to prepare subgrade, place, and remove forms and finish concrete in accordance with the plans and specifications.
- h. **Delete** Item 23 in its entirety.
- i. **Revise** basis for payment in Item 24 to read "will be made on a per cubic yard (C.Y.) basis".
- j. **Replace** Item 26 with the following:
 - 26. Payment for **"Remove Existing Curb or Concrete as Noted"** will be made on a per lineal foot (L.F.) basis, as specified in the bid schedule, which shall include all costs for labor, materials, equipment, permits/authorization, and performing all work required to saw cut and remove existing concrete curb, gutter, or spandrel, and legally dispose of the materials, in accordance with the plans and specifications.
- k. **Replace** Item 29 with the following:
 - 29. Payment for **"Relocate Existing Mailbox with New In-Ground Metal Post"** will be made on a per each (EA.) basis, as specified in the bid schedule, which shall include all costs for labor, materials, equipment, permits/authorization, and performing all work required to remove existing mailbox and footing, install mailbox in new location with new in-ground metal post and concrete footing, and legally dispose of removed materials, in accordance with the plans and specifications.

- I. **Delete** Item 30 in its entirety.

- m. **Replace** Item 33 with the following:
 - 33. Payment for **"Reconstruct In-Kind, Existing Private Owner Block Wall"** will be made on a per lineal foot (L.F.) basis, as specified in the bid schedule, which shall include all costs for labor, materials, equipment, permits/authorization, and performing all work required to remove the existing wall and footing, construct new wall to match existing in material and appearance (unless otherwise approved by Owner) in new location, and legally dispose of removed materials, in accordance with the plans and specifications.

- n. **Replace** Item 35 with the following:
 - 35. Payment for **"Reconstruct In-Kind, Existing Private Owner Wood Fence"** will be made on a per lineal foot (L.F.) basis, as specified in the bid schedule, which shall include all costs for labor, materials, equipment, permits/authorization, and performing all work required to remove the existing wood fence and footing, construct new wood fence to match existing in material and appearance (unless otherwise approved by Owner) in new location, and legally dispose of removed materials, in accordance with the plans and specifications.

- o. **Replace** Item 36 with the following:
 - 35. Payment for **"Reconstruct In-Kind, Existing Private Owner Wrought Iron Fence"** will be made on a per lineal foot (L.F.) basis, as specified in the bid schedule, which shall include all costs for labor, materials, equipment, permits/authorization, and performing all work required to remove the existing wrought iron fence and footing, install existing wrought iron fence panels in new location with new posts and footings, and legally dispose of removed materials, in accordance with the plans and specifications.

- p. **Delete** Item 37 in its entirety.

- q. **Replace** Item 38 with the following
38. Payment for **"Adjust to Grade Existing Vault"** will be made on a per each (EA.) basis, as specified in the bid schedule, which shall include all costs for labor, materials, equipment, permits/authorization, and performing all work required to adjust existing vault to grade per RCSD Standards, in accordance with the plans and specifications.
- r. **Add** the following sentence at the end of Item 41:
- Fire hydrant installation shall meet RCSD Standards.
- s. **Add** the following sentence at the end of Item 42:
- Water meter installation shall meet RCSD Standards.
- t. **Delete** Item 43 in its entirety.
- v. **Add** Items 77 through 102 as follows:
77. Payment for **"Install 2-Sack Slurry Backfill Over Storm Drain with Less than 2' Cover"** will be made on a per cubic yard (C.Y.) basis, as specified in the bid schedule, which shall include all costs for labor, materials, equipment, permits/authorization, and performing all work required to place 2-sack slurry backfill, in accordance with the plans and specifications.
78. Payment for **"Place Storm Drain Bedding and Backfill in Pipe Zone (to 12" Over Top of Pipe)"** will be made on a lump sum (L.S.) basis, as specified in the bid schedule, which shall include all costs for labor, materials, equipment, permits/authorization, and performing all work required to place storm drain bedding and backfill, in accordance with the plans and specifications.
79. Payment for **"Reconstruct Sewer Lateral per RCFC STD M808"** will be made on a per each (EA.) basis, as specified in the bid schedule, which shall include all costs for labor, materials, equipment, permits/authorization, and performing all work required to reconstruct sewer lateral, in accordance with the plans and specifications.

80. Payment for **"Furnish and Install Trench Protection in Accordance with Cal/OSHA Standards for Trenches Greater than 5' Deep"** will be made on a lump sum (L.S.) basis, as specified in the bid schedule, which shall include all costs for labor, materials, equipment, permits/authorization, and performing all work required to furnish and install trench protection, in accordance with the plans and specifications.
81. Payment for **"Construct Type A Retaining Curb per Addendum Detail"** will be made on a per lineal foot (L.F.) basis, as specified in the bid schedule, which shall include all costs for labor, materials, equipment, permits/authorization, and performing all work required to construct Type A retaining curb, in accordance with the plans and specifications.
82. Payment for **"Construct Type B Retaining Curb per Addendum Detail"** will be made on a per lineal foot (L.F.) basis, as specified in the bid schedule, which shall include all costs for labor, materials, equipment, permits/authorization, and performing all work required to construct Type B retaining curb, in accordance with the plans and specifications.
83. Payment for **"Construct Masonry Retaining Wall per Greenbook Standard Plan 816-3 H=3'-4" Max."** will be made on a per square foot (S.F.) basis, as specified in the bid schedule, which shall include all costs for labor, materials, equipment, permits/authorization, and performing all work required to construct masonry retaining wall, in accordance with the plans and specifications.
84. Payment for **"Encase Existing RCSD Sewer Main and Laterals with 2-Sack Slurry to RCSD Specifications within Street Lowering Area"** will be made on a per lineal foot (L.F.) basis, as specified in the bid schedule, which shall include all costs for labor, materials, equipment, permits/authorization, and performing all work required to encase existing RCSD sewer main and laterals, in accordance with the plans and specifications.
85. Payment for **"Construct Under Sidewalk Drain per Riverside County STD 309"** will be made on a per each (EA.) basis, as specified in the bid schedule, which shall include all costs for labor, materials, equipment, permits/authorization, and performing all work required to construct under sidewalk drain, in accordance with the plans and specifications. Contractor can assume a 7' drain for estimating purposes.

86. Payment for "**Construct Private Drain through Curb per Riverside County STD 310**" will be made on a per each (EA.) basis, as specified in the bid schedule, which shall include all costs for labor, materials, equipment, permits/authorization, and performing all work required to construct private drain, in accordance with the plans and specifications.
87. Payment for "**Pothole Existing Utilities as Required for Utility Relocation within Street Lowering Area**" will be made on a per each (EA.) basis, as specified in the bid schedule, which shall include all costs for labor, materials, equipment, permits/authorization, and performing all work required to perform potholing, as required, in accordance with the plans and specifications.
88. Payment for "**Horizontal Sawcut Existing Curb**" will be made on a per lineal foot (L.F.) basis, as specified in the bid schedule, which shall include all costs for labor, materials, equipment, permits/authorization, and performing all work required to sawcut and remove portions of existing curb as required for driveway installation, in accordance with the plans and specifications.
89. Payment for "**Construct 6" AC Berm per Riverside County STD 212**" will be made on a per square foot (S.F.) basis, as specified in the bid schedule, which shall include all costs for labor, materials, equipment, permits/authorization, and performing all work required to install AC berm, in accordance with the plans and specifications.
90. Payment for "**Remove Existing Concrete Residential Driveways**" will be made on a per square foot (S.F.) basis, as specified in the bid schedule, which shall include all costs for labor, materials, equipment, permits/authorization, and performing all work required to sawcut, remove, and legally dispose of removed materials, in accordance with the plans and specifications.
91. Payment for "**Remove Existing Concrete Structure**" will be made on a per each (EA.) basis, as specified in the bid schedule, which shall include all costs for labor, materials, equipment, permits/authorization, and performing all work required to demolish, remove, backfill, and recompact excavation area, and legally dispose of removed materials, in accordance with the plans and specifications.

92. Payment for **"Reconstruct In-Kind, Existing Private Owner Wrought Iron and Block Fence"** will be made on a per lineal foot (L.F.) basis, as specified in the bid schedule, which shall include all costs for labor, materials, equipment, permits/authorization, and performing all work required to demolish and remove existing wall, legally dispose of removed materials and reconstruct in new location, in accordance with the plans and specifications.
93. Payment for **"Relocate and/or Adjust to Grade Existing Private Owner Wrought Iron Gate, Recycle Wrought Iron Gate, and Install New V-Track and Footing"** will be made on a per lineal foot (L.F.) basis, as specified in the bid schedule, which shall include all costs for labor, materials, equipment, permits/authorization, and performing all work required to demolish and legally dispose of existing v-track and footing, and furnish and install new v-track and footing, in accordance with the plans and specifications.
94. Payment for **"Relocate and/or Adjust to Grade Existing Private Owner Chain Link Gate, and Recycle Material"** will be made on a per lineal foot (L.F.) basis, as specified in the bid schedule, which shall include all costs for labor, materials, equipment, permits/authorization, and performing all work required to relocate and/or adjust to grade existing private owner chain link gate, in accordance with the plans and specifications.
95. Payment for **"Relocate and/or Adjust to Grade Existing Private Owner Wood Gate, and Recycle Material"** will be made on a per lineal foot (L.F.) basis, as specified in the bid schedule, which shall include all costs for labor, materials, equipment, permits/authorization, and performing all work required to relocate and/or adjust to grade existing private owner wood gate, in accordance with the plans and specifications.
96. Payment for **"Construct Minimum 3" AC Paving Over Compacted Native Soil"** will be made on a per square foot basis, as specified in the bid schedule, which shall include all costs for labor, materials, equipment, permits/authorization, and performing all work required to excavate to subgrade or place backfill, as required, to grade, and compact and place AC paving, in accordance with the plans and specifications.
97. Payment for **"Construct 4" PCC Over Compacted Native Soil"** will be made on a per square foot basis, as specified in the bid schedule, which shall include all costs for labor, materials, equipment, permits/authorization, and performing all work required to excavate to subgrade or place backfill, as required, to grade, and compact and place PCC, in accordance with the plans and specifications.

98. Payment for **"Construct 4" AB or Gravel Surface for Driveway Matchup Purposes Over Compacted Native Soil"** will be made on a per square foot basis, as specified in the bid schedule, which shall include all costs for labor, materials, equipment, permits/authorization, and performing all work required to excavate to subgrade or place backfill, as required, to grade, and compact and place 4" gravel, in accordance with the plans and specifications.
99. Payment for **"Install Traffic Signal Loop to RCTD Standards"** will be made on a per each (EA.) basis, as specified in the bid schedule, which shall include all costs for labor, materials, equipment, permits/authorization, and performing all work required to install traffic loops and restore traffic signal function, in accordance with the plans and specifications.
100. Payment for **"Adjust Air-Vac to Grade per RCTD STD W1070"** will be made on a per each (EA.) basis, as specified in the bid schedule, which shall include all costs for labor, materials, equipment, permits/authorization, and performing all work required to adjust air-vac to grade, and provide concrete slab and cover as required, in accordance with the plans and specifications.
101. Payment for **"Relocate Existing Waterline per RCSD Standards as Required by Street Lowering"** will be made on a per lineal foot basis, as specified in the bid schedule, which shall include all costs for labor, materials, equipment, permits/authorization, and performing all work required to relocate existing waterline, in accordance with the plans and specifications. Contractor shall fill out Unit Prices and Total Prices for A, B, C; Contractor's do not need to place anything within the parent bid item 101.
102. Payment for **"Underground Unforeseen Conditions Allowance. To be used as approved and directed by Agency. Unused monies to be returned to Agency"** will be made on a time and material basis, as determined and directed by the Agency. As this is a Time and Material unit, the Agency shall only authorize payment and disbursement of this item for actual work performed under specific direction by the Agency.

10. **Reference:** Construction Specifications, Special Provisions, Section 3 - Duration of Contract, Page SP-1:

Replace the first paragraph with the following:

The Contractor must begin work no later than fourteen (14) days after the commencement date specified in the Notice to Proceed and must complete the entire work within three hundred sixty-five (365) calendar days from the date specified in the Notice to Proceed.

11. **Reference:** Construction Specifications, Special Provisions, Section 13 - Beginning of Work, Page SP-4:

Replace the third paragraph with the following:

All work must be completed within 365 calendar days from the date specified in the Notice to Proceed.

12. **Reference:** Construction Specifications, General Conditions, Article 3 Site Conditions, Page GC-11:

Delete the first sentence of Part 3.1.5.

13. **Reference:** Construction Specifications, General Conditions, Article 19 Changes, 19.1 Change Order Work, Page GC-38:

Add the following after Subpart c of Part 19.1.1:

If such changes reduce the quantity or amount of work to be done, they shall not constitute the basis for claim(s) for damages or anticipated profits on the work eliminated; provided, that if such changes render useless any work already done or material or equipment already furnished or used in the Work, Owner shall make reasonable allowance therefore, which action shall be binding upon both parties.

14. **Reference:** Construction Specifications, General Conditions, Article 19 Changes, 19.1 Change Order Work, Page GC-42:

Addendum No. 2 Deleted 19.1.20. Addendum No. 3 shall include Part 19.1.20 with the following:

19.1.20 Quantities shown on the Contract Drawings are estimates and must be verified by Contractor. Bid schedule may include bit item quantities that are not specified or do not agree with items on the Contract Drawings. Bid item quantities shall be a basis for Contractor's proposal and not constitute a basis for final payment. Final payment for unit cost items will be based upon actual quantities used and verified by Owner's inspector. Quantities shown and used to establish lump sum cost by Contractor are assumed to have been verified by Contractor prior to submitting a bid.

15. **Reference:** Construction Specifications, Technical Provisions, Specifications, Page TP-1:

Add the following to the end of the section titled "Specifications":

Where specified, this project shall also conform to the Standards and Specifications of the Riverside County Flood Control and Water Conservation District.

16. **Reference:** Construction Specifications, Technical Provisions, Article 23 Overall Construction Methods, 23.1 Project Site, Pages TP-1 and TP-2:

Replace the last two paragraphs with the following:

The Contractor shall inform Agency a reasonable length of time in advance of the times and places at which he intends to work in order that lines and grades may be furnished, that inspection may be provided, and that necessary measurements for records and payments may be made with minimum inconvenience. The Contractor shall provide such assistance and materials as may be required. The Contractor shall carefully preserve all survey stakes and reference points. Should any stakes or points be removed or destroyed by any act of the Contractor, they shall be reset at the Contractor's expense.

17. **Reference:** Construction Specifications, Technical Provisions, 30.5 Cold Plane Asphalt Concrete Pavement, Pages TP-10 and TP-11:

Revise depth from 0.17' to 0.10' in first paragraph and **revise** unit for unit bid price from square yard to cubic yard in last paragraph.

18. **Reference:** Construction Specifications, Technical Provisions, 32.5 through 32.8, Pages TP-19 through TP-23:

Delete all but the first paragraph of Part 32.5 on Page TP-19 and **delete** all of Parts 32.6, 32.7, and 32.8 on Pages TP-19 through TP-23. No rubberized asphalt is required under this project.

19. **Reference:** Construction Specifications, Technical Provisions, Part 32.9, Page TP-24:

Revise sentence in middle of Page TP-24 from "The paving asphalt shall be AR-4000" to read "The paving asphalt shall be PG64-10 per RCTD Road Improvement Standards and Specifications, Ordinance 461, Section 11".

20. **Reference:** Construction Specifications, Technical Provisions, Parts 32.10 through 32.13, Pages TP-26 through TP-28:

Delete Parts 32.10 through 32.13, these items are not required for this project.

21. **Reference:** Construction Specifications, Technical Provisions, Article 33 Concrete Curb, Gutter, Cross Gutter, Spandrel, Driveway Approaches, Sidewalk and Curb Ramps, Page TP-29:

Replace the third paragraph with the following:

Excess material resulting from the excavation of the subgrade will become property of the Contractor and be disposed of as provided in Section 7-1.13 of the Standard Specifications. Full compensation for the removal of existing concrete structures shall be included in the contract bid prices for such bid items.

Replace the last paragraph with the following:

The contract unit prices paid per linear foot for Curb and Gutter, per square foot for Sidewalk, Cross Gutter, Spandrels, and Driveway Approaches, and per each for Curb Ramps shall include full compensation for furnishing all labor, equipment, materials, and tools, and incidentals, and for performing all work involved in the construction, complete and in place, including the furnishing and placing of expansion joints.

22. **Reference:** Construction Specifications, Technical Provisions, 33.1 Driveway Tie In, Page TP-29:

Replace the third paragraph with the following:

Excess material resulting from the removal and regrading of existing driveways will become property of the Contractor and be disposed of as provided in Section 7-1.13 of the Standard Specifications.

23. **Reference:** Construction Specifications, Technical Provisions, 33.2 Catch Basin and Retaining Wall, Page TP-30:

Replace with the following:

All catch basins shall be constructed to Riverside County Transportation Department (RCTD) Standards and conform to applicable portions of RCTD Ordinance 461, Section 14.

Retaining walls shall be constructed in accordance with the "Greenbook" Standard Plans and Specifications for Public Works Construction.

Full compensation for furnishing and placing of reinforcement and grate cover, structure excavation, and backfill shall be included in the unit prices bid per each for Catch Basins and per square foot for Retaining Wall, and shall include full

compensation for furnishing all labor, materials, tools, and equipment, and no additional compensation will be allowed therefore.

24. **Reference:** Construction Specifications, Technical Provisions, Page TP-32:

Add the following Part 33.7 following Part 33.6:

33.7 Concrete Damage, Repair, and Protection from Graffiti

Any damage, cracks, or defects in new or existing concrete including but not limited to curbs, gutters, sidewalks, walls and driveways occurring during the course of the project shall be repaired by Contractor to the satisfaction of the Owner. Patching of damaged areas will not be allowed. Damaged, cracked, or defective areas are to be removed and replaced to nearest score line as directed by the Owner at Contractor's expense.

Newly poured concrete shall be protected and guarded from graffiti until concrete has cured sufficiently to resist such vandalism. Failure to prevent graffiti will result in defaced concrete being removed and replaced to nearest score line as directed by the Owner at Contractor's expense. Contractor is advised that preventative steps may include guarding the project after normal working hours and that such preventative measures will not constitute extra work.

25. **Reference:** Construction Specifications, Technical Provisions, Part 33.5 Relocate Signs and Fence, Page TP-31:

Replace with the following:

33.5.1 Relocate Signs

Sign relocation shall conform to the provisions in Section 56 of the Standard Specifications and as directed by the Engineer.

Signs shall be relocated at the locations shown on the construction plans or where directed by the Engineer.

The contract unit price paid per each for Relocate Sign shall include full compensation for furnishing all labor, materials, tools, equipment, and incidentals and for performing all work involved, and no additional compensation will be allowed therefore.

33.5.2 Relocate and/or Reconstruct Fences and Walls

Contractor shall relocate and/or reconstruct fences and walls as noted on the plans unless directed otherwise by Owner.

Relocate Fence - Contractor shall use existing material ("recycle") where possible and install same with new footings in new location. If material cannot be reused (recycled), new material shall match existing or be replaced by Owner-approved equal.

Reconstruct In-Kind Fences and Walls - Contractor shall construct new wall or fence in new location to match existing wall fence material(s) and appearance. Contractor shall reuse (recycle) existing materials (wrought iron panels, concrete wall capstones, etc.) where possible. If Contractor is unable to reuse (recycle) existing materials or match existing configuration and appearance, Contractor shall obtain Owner approval for equal.

Recycle shall be defined herein as the incorporation of existing materials with new construction.

The contract unit price paid per lineal foot for Relocate and/or Reconstruct Fences and Walls shall include full compensation for furnishing all labor, materials, tools, equipment, and incidentals and for performing all work involved, and no additional compensation will be allowed therefore.

If determined, the Agency shall address any further clarifications within subsequent Addendums.

By: _____

Erik Sydow
Project Manager

Date: _____



**REDEVELOPMENT AGENCY FOR THE COUNTY OF RIVERSIDE
CONTRACT DOCUMENTS FOR THE
RUBIDOUX AREA II STREET AND STORM DRAIN IMPROVEMENT PROJECT**

ADDENDUM No. 2

Please Be Advised: the Agency hereby updates the following sections of the plans and specifications:

1. Reference: Construction Specifications, Section I Bidding Requirements, Contractor's Proposal:
 - a. The Contractor's Proposal has been updated in its entirety to reflect the updated field survey plans. There are now 102 items to bid on.
2. Reference: Construction Specifications, Section III General Conditions, Article 19 Changes, Page GC-42:
 - a. Section 19.1.20 of the Section shall be deleted in its entirety from the specification package and not apply to construction.
3. Reference: Street Improvement Plans
 - a. Street Improvement Plans, Pages 6-28 have been updated and are included within this Addendum.
4. Reference: Street Improvement Plans
 - a. Street Improvement Plan Construction Notes have been updated and included within this Addendum. This includes 3 figures for reference.
5. Reference: Storm Drain Plans
 - a. Missing Storm Drain Plans, sheets 17 and 18 are included within this Addendum.
6. Reference: Construction Specifications, Section I Bidding Requirements, Contractor's Proposal:
 - a. Bid Item 45 referencing "Const. New Street Lighting Electrical System in accordance with the Rubidoux Area II Electrical Infrastructure Installation Specifications" is included in Addendum and entitled the "Redevelopment Agency for the County of Riverside Rubidoux Area II Electrical Infrastructure Installation"
7. Soils Report: Attached is the draft version of the soils report from Heider Engineering, dated May 18, 2011, Project No. 110055. A final report, with no substantial changes, may be issued with a future Addendum.

If determined, the Agency shall address any further clarifications within subsequent Addendums.

By:  _____

Erik Sydow
Project Manager

Date: 8/19/11 _____



ADDENDUM NO. 1, Page 1 of 1

**REDEVELOPMENT AGENCY FOR THE COUNTY OF RIVERSIDE
CONTRACT DOCUMENTS FOR THE
RUBIDOUX AREA II STREET AND STORM DRAIN IMPROVEMENT PROJECT**

ADDENDUM No. 1

Please Be Advised: the Agency hereby updates the following sections of the plans and specifications:

1. Reference: Construction Specifications, Notice Inviting Bids, Page BD-1:
 - a. Proposals shall hereby be delivered to the Clerk of the Board of Directors, on the 1st floor of the County Administrative Center located at 4080 Lemon Street, 1st Floor, Riverside, CA 92501, no later than 10:00 a.m., on May 26, 2011 to be promptly opened in public at said address.

If determined, the Agency shall address any further clarifications within subsequent Addendums.

By: 

Erik Sydow
Project Manager

Date: 5/2/11 _____

S:\RDACOMDIS2\Rubidoux\Rubidoux Area 2\Addendum No. 1.doc

CONTRACTOR'S PROPOSAL

TO THE GOVERNING BOARD OF
THE REDEVELOPMENT AGENCY

FOR THE COUNTY OF RIVERSIDE

Date 6/3/11
All American Asphalt
Bidder

The undersigned, having carefully examined the proposed site and the Plans and Specifications, the Notice Inviting Bids, the Instructions to Bidders, the Agreement Form, the Bond Forms, the General Conditions and the Supplementary General Conditions for the Rubidoux, Area II Street And Storm Drain Improvement Project, hereby proposes and agrees to furnish all tools, equipment, services, apparatus, facilities, transportation, labor and materials necessary to complete the construction in strict conformity with the Plans and Specifications, including all work specified in Addenda numbered and dated:

Addendum No. <u>1</u>	Date ^{RB} <u>5/2/11</u>
Addendum No. <u>2</u>	Date <u>5/19/11</u>
Addendum No. <u>3</u>	Date <u>5/24/11</u>
Addendum No. <u>4</u>	Date <u>6/1/11</u>

for the total sum, including all applicable taxes, permits and licenses as follows:

Item No.	Description	Unit	Estimated Quantity	Unit Prices (in figures) Dollars/Cents	Item Total (in figures) Dollars/Cents
1	Mobilization	LS	1	358000-	358000-
2	Storm Water Pollution Prevention Plan and NOI	LS	1	215000-	215000-
3	Not Used				
4	Clearing and Grubbing	LS	1	2460-	2460-
5	Traffic Control	LS	1	121000-	121000-
6	Not Used				
7	Signing and Striping	LS	1	19600- ^{RB} 19600-	19600-
8	Develop Water Supply	LS	1	2600-	2600-
9	Roadway Excavation	CY	18,148	19.50	353886.00

Item No.	Description	Unit	Estimated Quantity	Unit Prices (in figures) Dollars/Cents	Item Total (in figures) Dollars/Cents
10	Place AC Pavement (See Street Improvement Plan Sht 2 for Course Thickness)	TON	7,600	08-	516800-
11	Place Aggregate Base	CY	7,700	22-	169400-
12	Fog Seal	SF	407,000	.04	16280-
13	Construct 6" Type A-6 Curb and Gutter	LF	13,200	11-	145200-
14	Construct 4" Sidewalk	SF	76,000	1.56	118560-
15	Construct Driveway Approach	SF	48,000	2.38	114240-
16	Construct Access Ramp	EA	38	2300-	87400-
17	Adjust MH Cover to Grade	EA	43	020-	26660-
18	Adjust Valve Cover to Grade	EA	74	286-	21164-
19	Remove Existing Catch Basin	EA	3	2200-	6600-
20	Cold Plane 0.1' Existing Pavement	SF	42,000	.39	16380-
21	Construct 0.1' AC Overlay	SY	7,500	8.85 3.85	28875-
22	Construct Cross Gutter, Spandrel and Curb Return	SF	4,250	4.40	18700-
23	Not Used				
24	Remove Existing AC and Base	CY	6,000	9.35	56100-
25	Remove Existing Tree	EA	91	550-	50050-
26	Remove Existing Curb or Conc. as Noted	LF	500	15.60	7800-

Item No.	Description	Unit	Estimated Quantity	Unit Prices (in figures) Dollars/Cents	Item Total (in figures) Dollars/Cents
27	Remove Existing Guard Post	EA	14	104-	1456-
28	Relocate Existing Sign and Post	EA	43	286-	12298-
29	Relocate Existing Mailbox with New In-Ground Metal Post	EA	250	260-	65000-
30	Not Used				
31	Relocate Existing Drain	EA	2	2000-	4000-
32	Relocate Private Lamp	EA	1	260-	260-
33	Reconstruct In-Kind Exist. Private Owner Block Wall	LF	200	260-	52000- KB
34	Relocate Exist. Private Owner Chain Link Fence, Recycle Material	LF	4,000	36-	144000-
35	Reconstruct In-Kind Exist. Private Owner Wood Fence	LF	400	34.60	13840-
36	Reconstruct In-Kind Exist. Private Owner Wrought Iron Fence, Recycle Panels with New Posts	LF	500	44.34- PB	17000-
37	Abandon Existing Backflow Preventer to RCSD Standards	EA	1	2000-	2000-
38	Adjust to Grade Existing Vault	EA	1	1300-	1300-
39	Construct Desilting Drain Inlet	EA	4	3000-	12000-
40	Install Type "F" Markers	EA	4	260-	1040-
41	Relocate Existing Fire Hydrant per RCSD Std. W1050 and Detail Sht 3	EA	20	2200-	44000-

Item No.	Description	Unit	Estimated Quantity	Unit Prices (in figures) Dollars/Cents	Item Total (in figures) Dollars/Cents
42	Relocate Existing Water Meter per RCSD Std. W1100 and Detail Sht 3	EA	280	562-	157360-
43	Not Used				
44	Relocate Existing Irrigation Control Valve	EA	10	1200-	12000-
45	Const. New Street Lighting Electrical System in accordance with the Rubidoux Area II Electrical Infrastructure Installation Specifications	LS	1	135000-	135000-
46	Install 18" RCP (2000-D)	LF	1,237	114-	141018-
47	Install 24" RCP (2000-D)	LF	3,335	125-	416875-
48	Install 36" RCP (1500-D)	LF	577	164-	94628-
49	Install 42" RCP (1200-D)	LF	724	187-	135388-
50	Install 48" RCP (1500-D)	LF	584	220-	128480-
51	Install 60" RCP (1600-D)	LF	233	290-	67570-
52	Install Catch Basin STD 300 W=7'	EA	26	4500-	117000-
53	Install Catch Basin STD 300 W=14'	EA	18	5900-	106200-
54	Install Catch Basin STD 300 W=22'	EA	1	9200-	9200-
55	Install Catch Basin STD 302 W=7'	EA	2	5600-	11200-
56	Install Drop Inlet STD CB110	EA	1	3540-	3540-

Item No.	Description	Unit	Estimated Quantity	Unit Prices (in figures) Dollars/Cents	Item Total (in figures) Dollars/Cents
57	Construct Manhole Structure STD MH253 #3	EA	1	2640-	2640-
58	Construct Manhole Structure STD MH254 #4	EA	6	7200-	43200-
59	Construct Manhole Structure STD MH251 #1	EA	8	4700-	37600-
60	Construct Modified Manhole Structure STD 251 #1	EA	1	4160-	4160-
61	Construct Manhole Structure STD MH252 #2	EA	1	5300-	5300-
62	Construct Manhole Structure STD JS227 #2	EA	3	2430-	7290-
63	Construct Frame and Cover for Catch Basin STD CB103	EA	1	630-	630-
64	Construct Junction Structure STD JS226 #1	EA	1	2250-	2250-
65	Construct Junction Structure STD JS229 #4	EA	3	1460-	4380-
66	Construct Transition Structure STD TS303 #3	EA	13	3430-	44590-
67	Construct Modified Transition Structure STD TS304 #4	EA	1	40600-	40600-
68	Construct Modified Transition Structure STD TS301 #1	EA	2	5200-	10400-
69	Construct Modified Transition Structure STD TS301 #1	EA	1	5000-	5000-
70	Construct 3'x4' RCB per Caltrans STD D-80	LF	4	1220-	4880-
71	Construct 3'x5' RCB per Caltrans STD D-80	LF	4	1220-	4880-

Item No.	Description	Unit	Estimated Quantity	Unit Prices (in figures) Dollars/Cents	Item Total (in figures) Dollars/Cents
72	Construct Headwall Structure per Caltrans STD D-89	EA	1	6100-	6100-
73	Install Sewer Steel Casing	LF	24	1060-	25440-
74	Construct Concrete Collar	EA	1	1300-	1300-
75	Concrete Encasement per RCFC M807	EA	12	76-	912-
76	Construct Concrete Bulkhead	EA	1	2660-	2660-
77	Install 2-Sack Slurry Backfill Over Storm Drain with less than 2' Cover	CY	400	86-	34400-
78	Place Storm Drain Bedding and Backfill in Pipe Zone (to 12" over top of pipe). Material to consist of clean plant manufactured sand having a minimum Sand Equivalent of 30 or approved equal.	LS	1	22500-	22500-
79	Reconstruct Sewer Lateral per RCFC Std. M808	EA	55	1410-	77550-
80	Furnish and Install Trench Protection in accordance with Cal/OSHA Standards for Trenches greater than 5' Deep	LS	1	5700-	5700-
81	Const. Type A Retaining Curb per Addendum Detail, as required.	LF	1,800	20.80	37440-

Item No.	Description	Unit	Estimated Quantity	Unit Prices (in figures) Dollars/Cents	Item Total (in figures) Dollars/Cents
82	Const. Type B Retaining Curb per Addendum Detail, as required.	LF	2,600	20.80	54080-
83	Const. Masonry Retaining Wall per Greenbook Std Plan 618-3 H=3'-4" Max.	SF	4,300	25-	107500-
84	Encase Exist. RCSD Sewer Main and Laterals with 2-sack slurry to RCSD specifications within Street lowering area delineated on Street Improvement Plan Sheet No. 9, 10 and 27	LF	1,100	39.50 X PB	43450-
85	Const. Under Sidewalk Drain per Riverside Cnty Std No. 309, as required. (Location not Specified)	EA	20	3430-	68600-
86	Const. Private Drain through Curb per Riverside Cnty Std No. 310 as required. (Location not Specified)	EA	20	416-	8320-
87	Pothole Exist. Utilities as required for Utility Relocation within Street lowering area delineated on Street Improvement Plan Sheet No. 9, 10 and 27	EA	50	550-	27500-
88	Horiz. Sawcut Existing Curb as required for D/W Approach Const.	LF	400	13.20	5280-

Item No.	Description	Unit	Estimated Quantity	Unit Prices (in figures) Dollars/Cents	Item Total (in figures) Dollars/Cents
89	Const. 6" AC Berm per Cnty Std No. 212	LF	500	8.80	4400-
90	Remove Existing Concrete Sawcut at Removal Limits. Field Verify Removal Limits of All Exist. Residential Driveways with Inspector Prior to Sawcut and Removal	SF	43,000	1.82	78200-
91	Remove Exist. Concrete Structure	EA	1	4400-	4400-
92	Reconstruct In-Kind Exist. Private Owner Wrought Iron and Block Fence as Required, Recycle W.I. Panels	LF	900	202-	181800-
93	Relocate and/or Adjust to Grade Exist. Private Owner Wrought Iron Gate. Recycle Gate and Install New V-Track and Footing, if Required	LF	2,000	58-	116000-
94	Relocate and/or Adjust to Grade Exist. Private Owner Chain Link Gate, Recycle Material	LF	1,400	37-	51800-
95	Relocate and/or Adjust to Grade Exist. Private Owner Wood Gate, Recycle Material	LF	50	72-	3600-
96	Const. Min. 3" AC Paving Over Compacted Native Soil (90% Min.)	SF	3,300	1.42	4686-
97	Const. 4" PCC Over Compacted Native Soil (90% Min.)	SF	42,000	1.96	82320-

Item No.	Description	Unit	Estimated Quantity	Unit Prices (in figures) Dollars/Cents	Item Total (in figures) Dollars/Cents
98	Const. 4" A.B. or Gravel Surface for Driveway Match-Up Purposes Over Compacted Native Soil (90% Min.)	SF	7,800	.36	2808-
99	Install Traffic Signal Loop to RCTD Standards	EA	4	400-	1600-
100	Adjust Air-Vac to Grade per RCTD Std W1070	EA	3	3200-	9600-
101	Relocate Exist. Waterline per RCSD Standards as required by street lowering as shown on Sht No. 9, 10, and 27				
A	Relocate Exist. 6" Waterline	LF	650	123-	79950-
B	Relocate Exist. 8" Waterline	LF	75	108-	8100-
C	Relocate Exist. 12" Waterline	LF	250	85-	21250-
102	Underground Unforeseen Conditions Allowance. To be used as approved and directed by Agency. Unused monies to be returned to Agency.	T&M	1	\$150,000	\$150,000
104	Hot Tap and connect to Existing 6" A.C.P. Waterline.	EA	4	2300-	9200-
105	Hot Tap and connect to Existing 8" D.I.P. Waterline.	EA	2	2900-	5800-
106	Hot Tap and connect to Existing 12" PVC Waterline.	EA	2	3200-	6400-
107	Encase Existing 6" A.C.P. Waterline	LF	650	25-	16250-

Item No.	Description	Unit	Estimated Quantity	Unit Prices (in figures) Dollars/Cents	Item Total (in figures) Dollars/Cents
108	Encase Existing 8" D.I.P Waterline	LF	75	25-	1875-
109	Encase Existing 12" PVC Waterline	LF	250	36-	9000-
110	Connect Existing Water Meter to New Water Main.	EA	20	1250-	25000-

TOTAL SUM BID, ITEMS 1 THROUGH 110: five million nine hundred
ninety nine thousand thirty (Words) (\$ 5,999,039.00)
nine dollars and zero cents (Figures)

The determination of the low bidder will be based on the Base Bid. Bids must be submitted on all items. Failure to bid on all items may result in the bid being rejected as non-responsive.

PAYMENT FOR ITEMS

The following bid items are included in the Bid Proposal for providing a method of payment:

1. Payment for **“Mobilization”** will be made on a lump sum (L.S.) basis, as specified in the bid schedule, which shall include all costs for labor, materials, equipment and permits/authorization required to establish a construction staging area(s) and place a construction trailer and equipment in accordance with the specifications.
2. Payment for **“Storm Water Pollution Prevention Plan & Notice of Intent”** will be made on a lump sum (L.S.) basis, as specified in the bid schedule, which shall include all costs for labor, materials, equipment and permits/authorization required to prepare and implement a storm water pollution prevention plan in accordance with the plans and specifications.
3. Payment for **“Construction Surveying”** will be made on a lump sum (L.S.) basis, as specified in the bid schedule, which shall include all costs for labor, materials, equipment and permits/authorization required to provide construction surveying, staking, establishment of street center lines, etc. in accordance with the plans and specifications.
4. Payment for **“Clearing and Grubbing”** will be made on a lump sum (L.S.) basis, as specified in the bid schedule, which shall include all costs for labor, materials, equipment and permits/authorization required to remove and dispose of resulting material in accordance with the plans and specifications.
5. Payment for **“Traffic Control”** will be made on a lump sum (L.S.) basis, as specified in the bid schedule, which shall include all costs for labor, materials, equipment and permits/authorization required to prepare and gain approval of a traffic control plan and implement traffic control measures in accordance with the plans and specifications.
6. Payment for **“Soils and Material Testing”** will be made on a lump sum (L.S.) basis, as specified in the bid schedule, which shall include all costs for labor, materials, equipment and permits/authorization required to provide soils and material testing and approvals in accordance with the specifications.
7. Payment for **“Signing and Striping”** will be made on a lump sum (L.S.) basis, as specified in the bid schedule, which shall include all costs for labor, materials, equipment and permits/authorization required to provide signing and striping in accordance with the plans and specifications.
8. Payment for **“Developing Water Supply”** will be made on a lump sum (L.S.) basis, as specified in the bid schedule, which shall include all costs for labor, materials, equipment and permits/authorization required to develop a water supply in accordance with the specifications.
9. Payment for **“Roadway Excavation”** will be made on a per cubic yard (C.Y.) basis, as specified in the bid schedule, which shall include all costs for labor, materials, equipment, permits/authorization and performing all work required for excavating, sloping, rounding tops and ends of excavations, loading, hauling, depositing, spreading and compacting the material complete in place and preparing subgrade at the grading plane in accordance with the plans and specifications.
10. Payment for **“Place 3” AC Pavement”** will be made on a per ton (TON) basis, as specified in the bid schedule, which shall include all costs for labor, materials,

11. Payment for **“Place Aggregate Base”** will be made on a per cubic yard (C.Y.) basis, as specified in the bid schedule, which shall include all costs for labor, materials, equipment, permits/authorization and performing all work required to provide, place and compact aggregate base in accordance with the plans and specifications.
12. Payment for **“Fog Seal”** will be made on a per square foot (S.F.) basis, as specified in the bid schedule, which shall include all costs for labor, materials, equipment, permits/authorization and performing all work required to apply fog sealant to AC pavement in accordance with the plans and specifications.
13. Payment for **“Construct 6” Type A-6 Curb and Gutter”** will be made on a per lineal foot (L.F.) basis, as specified in the bid schedule, which shall include all costs for labor, materials, equipment, permits/authorization and performing all work required to prepare subgrade, place and remove forms and finish concrete in accordance with the plans and specifications.
14. Payment for **“ Construct 4” Sidewalk”** will be made on a per square foot (S.F.) basis, as specified in the bid schedule, which shall include all costs for labor, materials, equipment, permits/authorization and performing all work required to prepare subgrade, place and remove forms and finish concrete in accordance with the plans and specifications.
15. Payment for **“Construct Driveway Approach”** will be made on a per square foot (S.A.) basis, as specified in the bid schedule, which shall include all costs for labor, materials, equipment, permits/authorization and performing all work required to prepare subgrade, place and remove forms and finish concrete in accordance with the plans and specifications.
16. Payment for **“Construct Access Ramp”** will be made on a per each (E.A.) basis, as specified in the bid schedule, which shall include all costs for labor, materials, equipment, permits/authorization and performing all work required to prepare subgrade, place and remove forms and finish concrete in accordance with the plans and specifications.
17. Payment for **“Adjust Manhole Cover to Grade”** will be made on a per each (E.A.) basis, as specified in the bid schedule, which shall include all costs for labor, materials, equipment, permits/authorization and performing all work required to adjust existing manholes to grade in accordance with the plans and specifications.
18. Payment for **“Adjust Valve Cover to Grade”** will be made on a per each (E.A.) basis, as specified in the bid schedule, which shall include all costs for labor, materials, equipment, permits/authorization and performing all work required to adjust existing valve covers and cans to grade in accordance with the plans and specifications.
19. Payment for **“Remove Existing Catch Basin”** will be made on a per each (E.A.) basis, as specified in the bid schedule, which shall include all costs for labor, materials, equipment, permits/authorization and performing all work required to remove the existing catch basin and legally dispose of the material in accordance with the plans and specifications.
20. Payment for **“Cold Plane 0.1' Existing Pavement”** will be made on a per square foot (S.F.) basis, as specified in the bid schedule, which shall include all costs for labor, materials, equipment, permits/authorization and performing all work required to

21. Payment for **“Construct 0.1' AC Overlay”** will be made on a per square yard (S.Y.) basis, as specified in the bid schedule, which shall include all costs for labor, materials, equipment, permits/authorization and performing all work required to construct AC overlay on existing pavement in accordance with the plans and specifications.
22. Payment for **“Construct Cross Gutter”** will be made on a per square foot (S.F.) basis, as specified in the bid schedule, which shall include all costs for labor, materials, equipment, permits/authorization and performing all work required to prepare subgrade, place and remove forms and finish concrete in accordance with the plans and specifications.
23. Payment for **“Construct 6” Slump Stone Wall”** will be made on a per square foot (S.F.) basis, as specified in the bid schedule, which shall include all costs for labor, materials, equipment, permits/authorization and performing all work required to prepare subgrade, place footing and construct 6” CMU slump stone screen wall in accordance with the plans and specifications.
24. Payment for **“Remove Existing AC and Base”** will be made on a per square foot (S.F.) basis, as specified in the bid schedule, which shall include all costs for labor, materials, equipment, permits/authorization and performing all work required to saw cut and remove existing asphalt concrete pavement and aggregate base and legally dispose of the material in accordance with the plans and specifications.
25. Payment for **“Remove Existing Tree”** will be made on a per each (E.A.) basis, as specified in the bid schedule, which shall include all costs for labor, materials, equipment, permits/authorization and performing all work required to remove the existing tree, bush or stump, fill and compact the hole and legally dispose of the material in accordance with the plans and specifications.
26. Payment for **“Remove Existing Curb”** will be made on a per lineal foot (L.F.) basis, as specified in the bid schedule, which shall include all costs for labor, materials, equipment, permits/authorization and performing all work required to saw cut and remove existing concrete curb, gutter and or spandrel in accordance with the plans and specifications.
27. Payment for **“Remove Existing Guard Post”** will be made on a per each (E.A.) basis, as specified in the bid schedule, which shall include all costs for labor, materials, equipment, permits/authorization and performing all work required to remove the existing guard post and legally dispose of the material in accordance with the plans and specifications.
28. Payment for **“Relocate Existing Sign and Post”** will be made on a per each (E.A.) basis, as specified in the bid schedule, which shall include all costs for labor, materials, equipment, permits/authorization and performing all work required to remove existing sign and post and associated footing, install sign and post in new location and legally dispose of removed materials in accordance with the plans and specifications.
29. Payment for **“Relocate Existing Mailbox”** will be made on a per each (E.A.) basis, as specified in the bid schedule, which shall include all costs for labor, materials, equipment, permits/authorization and performing all work required to remove existing mailbox and footing, install mailbox in new location and legally dispose of removed

30. Payment for **“Replace 12 Existing Mailboxes with Gang Box”** will be made on a per each (E.A.) basis, as specified in the bid schedule, which shall include all costs for labor, materials, equipment, permits/authorization and performing all work required to remove the existing mailboxes and footings, install new gang box and legally dispose of removed materials in accordance with the plans and specifications.
31. Payment for **“Relocate Existing Drain”** will be made on a per each (E.A.) basis, as specified in the bid schedule, which shall include all costs for labor, materials, equipment, permits/authorization and performing all work required to remove the existing drain, install drain in new location and legally dispose of the removed materials in accordance with the plans and specifications.
32. Payment for **“Relocate Private Lamp”** will be made on a per each (E.A.) basis, as specified in the bid schedule, which shall include all costs for labor, materials, equipment, permits/authorization and performing all work required to remove existing private lamp and footing, install lamp in new location and legally dispose of removed materials in accordance with the plans and specifications.
33. Payment for **“Relocate Private Wall”** will be made on a per lineal foot (L.F.) basis, as specified in the bid schedule, which shall include all costs for labor, materials, equipment, permits/authorization and performing all work required to remove the existing wall, footing, construct wall in new location and legally dispose of removed materials in accordance with the plans and specifications.
34. Payment for **“Relocate Private Chain Link Fence”** will be made on a per lineal foot (L.F.) basis, as specified in the bid schedule, which shall include all costs for labor, materials, equipment, permits/authorization and performing all work required to remove existing chain link fence, footing, install chain link fence in new location and legally dispose of removed materials in accordance with the plans and specifications.
35. Payment for **“Relocate Private Wood Fence”** will be made on a per lineal foot (L.F.) basis, as specified in the bid schedule, which shall include all costs for labor, materials, equipment, permits/authorization and performing all work required to remove existing wood fence, footing, install wood fence in new location and legally dispose of removed materials in accordance with the plans and specifications.
36. Payment for **“Relocate Private Wrought Iron Fence”** will be made on a per lineal foot (L.F.) basis, as specified in the bid schedule, which shall include all costs for labor, materials, equipment, permits/authorization and performing all work required to remove the existing wrought iron fence, footing, install wrought iron fence in new location and legally dispose of removed materials in accordance with the plans and specifications.
37. Payment for **“Relocate Existing Backflow Device”** will be made on a per each (E.A.) basis, as specified in the bid schedule, which shall include all costs for labor, materials, equipment, permits/authorization and performing all work required to remove existing backflow device, install backflow device in new location and legally dispose of removed materials in accordance with the plans and specifications.
38. Payment for **“Relocate Existing Vault”** will be made on a per each (E.A.) basis, as specified in the bid schedule, which shall include all costs for labor, materials, equipment, permits/authorization and performing all work required to remove existing vault and appurtenances, install vault in new location and legally dispose of removed materials in accordance with the plans specifications.

39. Payment for **“Construct Desilting Drain Inlet”** will be made on a per each (E.A.) basis, as specified in the bid schedule, which shall include all costs for labor, materials, equipment, permits/authorization and performing all work required to prepare subgrade, place forms and reinforcement, remove forms and finish concrete in accordance with the plans and specifications.
40. Payment for **“Install Type F Markers”** will be made on a per each (E.A.) basis, as specified in the bid schedule, which shall include all costs for labor, materials, equipment, permits/authorization and performing all work required to install Type F road markers in accordance with the plans and specifications.
41. Payment for **“Relocate Existing Fire Hydrant”** will be made on a per each (E.A.) basis, as specified in the bid schedule, which shall include all costs for labor, materials, equipment, permits/authorization and performing all work required to remove existing fire hydrant and appurtenances, install fire hydrant in new location and legally dispose of removed materials in accordance with the plans and specifications.
42. Payment for **“Relocate Existing Water Meter”** will be made on a per each (E.A.) basis, as specified in the bid schedule, which shall include all costs for labor, materials, equipment, permits/authorization and performing all work required to remove existing water meter and appurtenances, install water meter in new location and legally dispose of removed materials in accordance with the plans and specifications.
43. Payment for **“Relocate Existing Fire Dept. Service”** will be made on a per each (E.A.) basis, as specified in the bid schedule, which shall include all costs for labor, materials, equipment, permits/authorization and performing all work required to remove existing Fire Department service and appurtenances, install Fire Department service in new location and legally dispose of removed materials in accordance with the plans and specifications.
44. Payment for **“Relocate Existing Irrigation Control Valve”** will be made on a per each (E.A.) basis, as specified in the bid schedule, which shall include all costs for labor, materials, equipment, permits/authorization and performing all work required to remove existing irrigation control valve and appurtenances, install irrigation control valve in new location and legally dispose of removed materials in accordance with the plans specifications.
45. Payment for **“Install New Street Light”** will be made on a per each (E.A.) basis, as specified in the bid schedule, which shall include all costs for labor, materials, equipment, permits/authorization and performing all work required to install street light in accordance with the plans and specifications.
46. Payment for **“Install 18” RCP (2000-D)”** will be made on a per lineal foot (L.F.) basis, as specified in the bid schedule, which shall include all costs for labor, materials, equipment, permits/authorization and performing all work required to trench, place bedding, install pipe, backfill and compact in accordance with the plans and specifications.
47. Payment for **“Install 24” RCP (2000-D)”** will be made on a per lineal foot (L.F.) basis, as specified in the bid schedule, which shall include all costs for labor, materials, equipment, permits/authorization and performing all work required to trench, place bedding, install pipe, backfill and compact in accordance with the plans and specifications.

48. Payment for **“Install 36” RCP (1500-D)** will be made on a per lineal foot (L.F.) basis, as specified in the bid schedule, which shall include all costs for labor, materials, equipment, permits/authorization and performing all work required to trench, place bedding, install pipe, backfill and compact in accordance with the plans and specifications.
49. Payment for **“Install 42” RCP (1200-D)** will be made on a per lineal foot (L.F.) basis, as specified in the bid schedule, which shall include all costs for labor, materials, equipment, permits/authorization and performing all work required to trench, place bedding, install pipe, backfill and compact in accordance with the plans and specifications.
50. Payment for **“Install 48” RCP (1500-D)** will be made on a per lineal foot (L.F.) basis, as specified in the bid schedule, which shall include all costs for labor, materials, equipment, permits/authorization and performing all work required to trench, place bedding, install pipe, backfill and compact in accordance with the plans and specifications.
51. Payment for **“Install 60” RCP (1600-D)** will be made on a per lineal foot (L.F.) basis, as specified in the bid schedule, which shall include all costs for labor, materials, equipment, permits/authorization and performing all work required to trench, place bedding, install pipe, backfill and compact in accordance with the plans and specifications.
52. Payment for **“Install Catch Basin STD 300 W=7”** will be made on a per each (E.A.) basis, as specified in the bid schedule, which shall include all costs for labor, materials, equipment, permits/authorization and performing all work required to prepare subgrade, place forms and reinforcement, remove forms and finish concrete in accordance with the plans specifications.
53. Payment for **“Install Catch Basin STD 300 W=14”** will be made on a per each (E.A.) basis, as specified in the bid schedule, which shall include all costs for labor, materials, equipment, permits/authorization and performing all work required to prepare subgrade, place forms and reinforcement, remove forms and finish concrete in accordance with the plans specifications.
54. Payment for **“Install Catch Basin STD 300 W=22”** will be made on a per each (E.A.) basis, as specified in the bid schedule, which shall include all costs for labor, materials, equipment, permits/authorization and performing all work required to prepare subgrade, place forms and reinforcement, remove forms and finish concrete in accordance with the plans specifications.
55. Payment for **“Install Catch Basin STD 302 W=7”** will be made on a per each (E.A.) basis, as specified in the bid schedule, which shall include all costs for labor, materials, equipment, permits/authorization and performing all work required to prepare subgrade, place forms and reinforcement, remove forms and finish concrete in accordance with the plans specifications.
56. Payment for **“Install Drop Inlet STD CB110”** will be made on a per each (E.A.) basis, as specified in the bid schedule, which shall include all costs for labor, materials, equipment, permits/authorization and performing all work required to prepare subgrade, place forms and reinforcement, remove forms and finish concrete in accordance with the plans specifications.
57. Payment for **“Construct Manhole Structure STD MH253 #3”** will be made on a per each (E.A.) basis, as specified in the bid schedule, which shall include all costs for

58. Payment for **“Construct Manhole Structure STD MH254 #4”** will be made on a per each (E.A.) basis, as specified in the bid schedule, which shall include all costs for labor, materials, equipment, permits/authorization and performing all work required to prepare subgrade, place forms and reinforcement, install cover, remove forms and finish concrete in accordance with the plans specifications.
59. Payment for **“Construct Manhole Structure STD MH251 #1”** will be made on a per each (E.A.) basis, as specified in the bid schedule, which shall include all costs for labor, materials, equipment, permits/authorization and performing all work required to prepare subgrade, place forms and reinforcement, install cover, remove forms and finish concrete in accordance with the plans specifications.
60. Payment for **“Construct Modified Manhole Structure STD MH251 #1”** will be made on a per each (E.A.) basis, as specified in the bid schedule, which shall include all costs for labor, materials, equipment, permits/authorization and performing all work required to prepare subgrade, place forms and reinforcement, install cover, remove forms and finish concrete in accordance with the plans specifications.
61. Payment for **“Construct Manhole Structure STD MH252 #2”** will be made on a per each (E.A.) basis, as specified in the bid schedule, which shall include all costs for labor, materials, equipment, permits/authorization and performing all work required to prepare subgrade, place forms and reinforcement, install cover, remove forms and finish concrete in accordance with the plans specifications.
62. Payment for **“Construct Manhole Structure STD JS227 #2”** will be made on a per each (E.A.) basis, as specified in the bid schedule, which shall include all costs for labor, materials, equipment, permits/authorization and performing all work required to prepare subgrade, place forms and reinforcement, install cover, remove forms and finish concrete in accordance with the plans specifications.
63. Payment for **“Construct Frame and Cover for Catch Basin STD CB103”** will be made on a per each (E.A.) basis, as specified in the bid schedule, which shall include all costs for labor, materials, equipment, permits/authorization and performing all work required to prepare subgrade, place forms and reinforcement, install cover, remove forms and finish concrete in accordance with the plans specifications.
64. Payment for **“Construct Junction Structure STD JS226 #1”** will be made on a per each (E.A.) basis, as specified in the bid schedule, which shall include all costs for labor, materials, equipment, permits/authorization and performing all work required to prepare subgrade, place forms and reinforcement, remove forms and finish concrete in accordance with the plans specifications.
65. Payment for **“Construct Junction Structure STD JS229 #4 ”** will be made on a per each (E.A.) basis, as specified in the bid schedule, which shall include all costs for labor, materials, equipment, permits/authorization and performing all work required to prepare subgrade, place forms and reinforcement, remove forms and finish concrete in accordance with the plans specifications.
66. Payment for **“Construct Transition Structure STD TS303 #3”** will be made on a per each (E.A.) basis, as specified in the bid schedule, which shall include all costs for labor, materials, equipment, permits/authorization and performing all work required to prepare subgrade, place forms and reinforcement, remove forms and

67. Payment for **“Construct Modified Transition Structure STD TS304 #4”** will be made on a per each (E.A.) basis, as specified in the bid schedule, which shall include all costs for labor, materials, equipment, permits/authorization and performing all work required to prepare subgrade, place forms and reinforcement, remove forms and finish concrete in accordance with the plans specifications.
68. Payment for **“Construct Modified Transition Structure STD TS301 #1”** will be made on a per each (E.A.) basis, as specified in the bid schedule, which shall include all costs for labor, materials, equipment, permits/authorization and performing all work required to prepare subgrade, place forms and reinforcement, remove forms and finish concrete in accordance with the plans specifications.
69. Payment for **“Construct Modified Transition Structure STD TS301 #1”** will be made on a per each (E.A.) basis, as specified in the bid schedule, which shall include all costs for labor, materials, equipment, permits/authorization and performing all work required to prepare subgrade, place forms and reinforcement, remove forms and finish concrete in accordance with the plans specifications.
70. Payment for **“Construct 3'x4' RCB per Caltrans STD D-80”** will be made on a per lineal foot (L.F.) basis, as specified in the bid schedule, which shall include all costs for labor, materials, equipment, permits/authorization and performing all work required to trench, place bedding, install box, backfill and compact in accordance with the plans and specifications.
71. Payment for **“Construct 3'x5' RCB per Caltrans STD D-80”** will be made on a per lineal foot (L.F.) basis, as specified in the bid schedule, which shall include all costs for labor, materials, equipment, permits/authorization and performing all work required to trench, place bedding, install box, backfill and compact in accordance with the plans and specifications.
72. Payment for **“Construct Headwall Structure per Caltrans STD D-89”** will be made on a per each (E.A.) basis, as specified in the bid schedule, which shall include all costs for labor, materials, equipment, permits/authorization and performing all work required to prepare subgrade, place forms and reinforcement, remove forms and finish concrete in accordance with the plans specifications.
73. Payment for **“Install Sewer Steel Casing”** will be made on a per lineal foot (L.F.) basis, as specified in the bid schedule, which shall include all costs for labor, materials, equipment, permits/authorization and performing all work required to install steel casing around the existing sewer line in accordance with the plans and specifications.
74. Payment for **“Construct Concrete Collar”** will be made on a per each (E.A.) basis, as specified in the bid schedule, which shall include all costs for labor, materials, equipment, permits/authorization and performing all work required to place and remove forms and finish concrete in accordance with the plans and specifications.
75. Payment for **“Construct Concrete Encasement”** will be made on a per lineal foot (L.F.) basis, as specified in the bid schedule, which shall include all costs for labor, materials, equipment, permits/authorization and performing all work required to place and remove forms and finish concrete in accordance with the plans and specifications.
76. Payment for **“Construct Concrete Bulkhead”** will be made on a per each (E.A.) basis, as specified in the bid schedule, which shall include all costs for labor,

DESIGNATION OF SUBCONTRACTORS

In compliance with the Public Contract Code, Sections 4104-4144, the undersigned submits the following complete list of each subcontractor who will perform work or labor or render services in or about the construction in an amount in excess of one-half of 1 percent of said total bid.

PORTION OF THE WORK	SUBCONTRACTOR	ADDRESS
Storm Drain	SRD Construction	Anaheim, CA
Trees/Clearing	Treesmith Enterprises	Anaheim, CA
Fence	ALCORN Fence	Riverside, CA Orange, CA
Masonry Walls	Ewandstrom Masonry	Torrance, CA
Surina Water	Surina	Bloomington, CA
Striping	PCI Striping	Long Beach, CA
electrical	Sierra Pacific	Riverside, CA

AWARD OF CONTRACT

The undersigned fully understands that a Contract is formed upon the acceptance of this proposal by the Owner, and the undersigned further agrees that upon request he will promptly execute and deliver to Owner a written memorial of the Contract together with the required labor and material and performance bonds.

BID GUARANTEE

The enclosed certified or cashier's check or bidder's bond on approved form, made payable to the Owner, in the amount of ten percent (10%) of the total bid submitted herewith, is hereby given as guarantee that the bidder will execute and deliver the above mentioned written memorial and required bonds if awarded the contract, and in the event that the undersigned fails or refuses to execute and deliver said documents, such check or bond is to be charged with the costs of the damages experienced by the Owner as a result of such failure or refusal, including, but not limited to publication costs, the difference in money between the amount of the bid of the said principal and the amount for which obligee may legally contract with another party to perform the said work if such amount be in excess of the former, building lease or rental costs, transportation costs and additional salary costs that result from the delay due to the principal's default on the awarded contract. In no event, however, shall the Surety's liability exceed the penal sum hereof.

Name of Bidder All American Asphalt
Type of Organization Corporation
Signed By Robert Bradley
Title of Signer Robert Bradley, Vice President
Address of Bidder P.O. Box 2229 Corona, CA 92878
Telephone Number 951-736-7600
Contractor's License 267073 Classification A, C-12

If bidder is a corporation, and signer is not President or Secretary, attach certified copy of Bylaws or resolution authorizing execution. If bidder is a corporation, affix corporate seal. If signer is an agent, attach Power of Attorney. If bidder is not an individual, list names of other persons authorized to bind the organization.



ALL AMERICAN ASPHALT ALL AMERICAN AGGREGATES

P.O. BOX 2229, CORONA, CA 92878-2229
STATE CONTRACTORS LICENSE #267073-A

CORPORATE RESOLUTION

Resolved, that this Corporation, All American Asphalt, on June 3, 2011, designated Robert Bradley to represent our Corporation in the capacity of Vice President.

A handwritten signature in blue ink, appearing to read 'Mark Luer', written over a horizontal line.

Mark Luer
Secretary

NON-COLLUSION AFFIDAVIT

TO BE EXECUTED BY BIDDER AND SUBMITTED WITH BID

STATE OF CALIFORNIA)
COUNTY OF RIVERSIDE)SS

Robert Bradley, being first duly sworn, deposes and says:

That he or she is Vice President of All American Asphalt

the party making the foregoing bid; that the bid is not made in the interest of, or on behalf of, any undisclosed person, partnership, company, association, organization, or corporation; that the bid is genuine and not collusive or sham; that the bidder has not directly or indirectly induced or solicited any other bidder to put in a false or sham bid, and has not directly or indirectly colluded, conspired, connived, or agreed with any bidder or anyone else to put in a sham bid, or that anyone shall refrain from bidding; that the bidder has not in any manner, directly or indirectly, sought by agreement, communication, or conference with anyone to fix the bid price of the bidder or any other bidder, or to fix any overhead, profit, or cost element of the bid price, or of that of any other bidder, or to secure any advantage against the public body awarding the contract of anyone interested in the proposed contract; that all statements contained in the bid are true; and, further, that the bidder has not, directly or indirectly, submitted his or her bid price or any breakdown thereof, or the contents thereof, or divulged information or data relative thereto, or paid, and will not pay, any fee to any depository, or to any member or agent thereof to effectuate a collusive or sham bid.

Robert Bradley
Signature
Robert Bradley, Vice President

Subscribed and sworn to before me this _____ day of _____, 200__

See attached
Signature of Officer Administering Oath

CALIFORNIA JURAT WITH AFFIANT STATEMENT

State of California

County of Riverside

Subscribed and sworn to (or affirmed) before me on this 3rd day of June, 2011.
Date Month

By (1) Robert Bradley
Name of Signer

Proved to me on the basis of satisfactory evidence be the person who appeared before me (.) (✓)

(and

(2) _____
Name of Signer

Proved to me on the basis of satisfactory evidence be the person who appeared before me.)

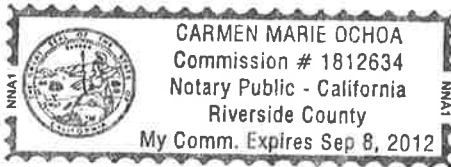

Signature Carmen Marie Ochoa
Signature of Notary Public

Place Notary Seal Above

OPTIONAL

Though the information below is not required by law, it may prove valuable to person relying on the document and could prevent fraudulent removal and reattachment of this form to another document.

Description of Attached Document

Title or Type of Document _____

Document Date: _____ Number of Pages: _____

Signer(s) Other Than Named Above: _____

Capacity(ies) Claimed by Signer(s)

Signer's Name: _____

- Individual
- Corporate Officer — Title(s): _____
- Partner — Limited General
- Attorney in Fact
- Trustee
- Other: _____

RIGHT THUMBPRINT OF SIGNER

Top of thumb here

Signer is Representing: _____

Signer's Name: _____

- Individual
- Corporate Officer — Title(s): _____
- Partner — Limited General
- Attorney in Fact
- Trustee
- Other: _____

RIGHT THUMBPRINT OF SIGNER

Top of thumb here

Signer is Representing: _____

BID BOND

KNOW ALL MEN BY THESE PRESENTS, that we, the undersigned
All American Asphalt

_____, as Principal : and Fidelity and Deposit Company of Maryland

_____, as Surety, are hereby held and firmly bound unto the Redevelopment Agency for
the County of Riverside, hereinafter called the "Owner", in the sum of

Ten Percent of
Total Bid Price in----- dollars (\$ 10% of Bid Amount) for the payment of which sum, well and truly to be
made, were hereby jointly and severally bind ourselves, our heirs, executors,
administrators, successors and assigns.

WHEREAS, the said Principal is herewith submitting its proposal for the construction of
Rubidoux, Area II Street And Storm Drain Improvement Project

THE CONDITION OF THE ABOVE OBLIGATION IS SUCH, that if the aforesaid Principal shall be awarded the contract upon said proposal and shall, within the required number of days after the notice of such award, execute a written memorial of the awarded contract and submit the required labor and material and faithful performance bond, then this obligation shall be null and void; and in the event that the principal fails and/or refuses to execute and deliver said documents this bond will be charged with the costs of the damages experienced by the Owner as a result of such refusal, including but not limited to, publication cost, the difference in money between the amount of the bid of the said principal and the amount for which the obligee may legally contract with another party to perform the said work if such amount be in excess of the former; building lease or rental costs, transportation costs, and additional salary costs that result from the delay due to the principal's default on the awarded contract. In no event however, shall the Surety's liability exceed the penal sum hereof.

The Surety, for value received, hereby stipulates and agrees that the obligations of said Surety and its bond shall be in no way impaired or affected by any extension of the time within which the Owner may accept such bid; and said Surety does hereby waive notice of any such extension.

IN WITNESS WHEREOF, the above-bounded parties have executed this instrument under their several seals this 4th day of May, 2011, the name and corporate seal of each corporate party being hereto affixed and these presents duly signed by its undersigned representative, pursuant to authority of its governing body.

In the presence of:

_____	_____ (Seal)
_____	Individual Principal
_____	_____
Address	Business Address
_____	_____ (Seal)
_____	Individual Principal
_____	_____
Address	Business Address

Attest:



 MARK Luer,
 Secretary

All American Asphalt

 Corporate Principal

400 East Sixth Street, Corona, CA 92879

 Business Address

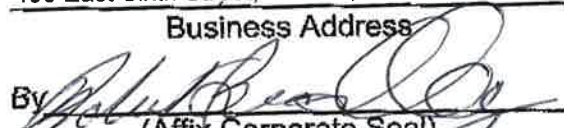
By 

 (Affix Corporate Seal)
 Robert Bradley Vice President

Attest:

Fidelity and Deposit Company of Maryland

 Corporate Principal Surety

801 N. Brand Boulevard, Penthouse Suite, Glendale, CA 91203

 Business Address

By 

 (Affix Corporate Seal)
 Owen M. Brown, Attorney-in-Fact

The rate of premium on this bond is N/A per thousand. Total amount of premium charged, \$ N/A.

(The above must be filled in by corporate surety.)

CALIFORNIA JURAT WITH AFFIANT STATEMENT

State of California

County of Riverside

Subscribed and sworn to (or affirmed) before me on this 6th day of June, 2011,
Date Month

By (1) Robert Bradley
Name of Signer

Proved to me on the basis of satisfactory evidence be the person who appeared before me (.) (.)

(and

(2) Mark Luer
Name of Signer

Proved to me on the basis of satisfactory evidence be the person who appeared before me.)

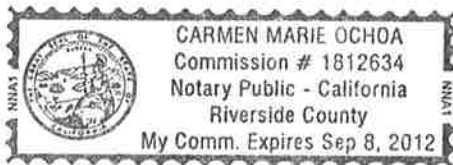

Signature Carmen Marie Ochoa
Signature of Notary Public

Place Notary Seal Above

OPTIONAL

Though the information below is not required by law, it may prove valuable to person relying on the document and could prevent fraudulent removal and reattachment of this form to another document.

Description of Attached Document

Title or Type of Document _____

Document Date: _____ Number of Pages: _____

Signer(s) Other Than Named Above: _____

Capacity(ies) Claimed by Signer(s)

Signer's Name: Robert Bradley

- Individual
- Corporate Officer — Title(s): _____
- Partner — Limited General
- Attorney in Fact
- Trustee
- Other: _____

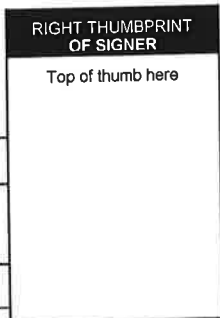

Signer is Representing:
All American Asphalt

Signer's Name: Mark Luer

- Individual
- Corporate Officer — Title(s): _____
- Partner — Limited General
- Attorney in Fact
- Trustee
- Other: _____

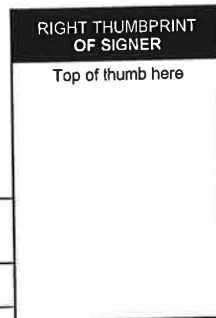

Signer is Representing:
All American Asphalt

CALIFORNIA ALL-PURPOSE ACKNOWLEDGMENT

State of California }
 County of Orange

On 05/04/11 before me, A. Wilkison, Notary Public
Date Here Insert Name and Title of the Officer

personally appeared Owen M. Brown
Name(s) of Signer(s)

who proved to me on the basis of satisfactory evidence to be the person(s) whose name(s) is/are subscribed to the within instrument and acknowledged to me that he/she/they executed the same in his/her/their authorized capacity(ies), and that by his/her/their signature(s) on the instrument the person(s), or the entity upon behalf of which the person(s) acted, executed the instrument.

I certify under PENALTY OF PERJURY under the laws of the State of California that the foregoing paragraph is true and correct.

WITNESS my hand and official seal.

Signature *A. Wilkison*
Signature of Notary Public



Place Notary Seal Above

OPTIONAL

Though the information below is not required by law, it may prove valuable to persons relying on the document and could prevent fraudulent removal and reattachment of this form to another document.

Description of Attached Document

Title or Type of Document: Bid Bond
 Document Date: 05/04/11 Number of Pages: Two (2)
 Signer(s) Other Than Named Above: All American Asphalt

Capacity(ies) Claimed by Signer(s)

Signer's Name: Owen M. Brown
 Individual
 Corporate Officer — Title(s): _____
 Partner — Limited General
 Attorney in Fact
 Trustee
 Guardian or Conservator
 Other: _____



Signer's Name: _____
 Individual
 Corporate Officer — Title(s): _____
 Partner — Limited General
 Attorney in Fact
 Trustee
 Guardian or Conservator
 Other: _____



Signer Is Representing: _____

Signer Is Representing: _____

Fidelity and Deposit Company of Maryland

EXTRACT FROM BY-LAWS OF FIDELITY AND DEPOSIT COMPANY OF MARYLAND

“Article VI, Section 2. The Chairman of the Board, or the President, or any Executive Vice-President, or any of the Senior Vice-Presidents or Vice-Presidents specially authorized so to do by the Board of Directors or by the Executive Committee, shall have power, by and with the concurrence of the Secretary or any one of the Assistant Secretaries, to appoint Resident Vice-Presidents, Assistant Vice-Presidents and Attorneys-in-Fact as the business of the Company may require, or to authorize any person or persons to execute on behalf of the Company any bonds, undertakings, recognizances, stipulations, policies, contracts, agreements, deeds, and releases and assignments of judgements, decrees, mortgages and instruments in the nature of mortgages,...and to affix the seal of the Company thereto.”

CERTIFICATE

I, the undersigned, Assistant Secretary of the FIDELITY AND DEPOSIT COMPANY OF MARYLAND, do hereby certify that the foregoing Power of Attorney is still in full force and effect on the date of this certificate; and I do further certify that the Vice-President who executed the said Power of Attorney was one of the additional Vice-Presidents specially authorized by the Board of Directors to appoint any Attorney-in-Fact as provided in Article VI, Section 2, of the By-Laws of the FIDELITY AND DEPOSIT COMPANY OF MARYLAND.

This Power of Attorney and Certificate may be signed by facsimile under and by authority of the following resolution of the Board of Directors of the FIDELITY AND DEPOSIT COMPANY OF MARYLAND at a meeting duly called and held on the 10th day of May, 1990.

RESOLVED: "That the facsimile or mechanically reproduced seal of the company and facsimile or mechanically reproduced signature of any Vice-President, Secretary, or Assistant Secretary of the Company, whether made heretofore or hereafter, wherever appearing upon a certified copy of any power of attorney issued by the Company, shall be valid and binding upon the Company with the same force and effect as though manually affixed."

IN TESTIMONY WHEREOF, I have hereunto subscribed my name and affixed the corporate seal of the said Company,

this 4th day of May, 2011.



Assistant Secretary

**Power of Attorney
FIDELITY AND DEPOSIT COMPANY OF MARYLAND**

KNOW ALL MEN BY THESE PRESENTS: That the FIDELITY AND DEPOSIT COMPANY OF MARYLAND, a corporation of the State of Maryland, by WILLIAM J. MILLS, Vice President, and GREGORY E. MURRAY, Assistant Secretary, in pursuance of authority granted by Article VI, Section 2, of the By-Laws of said Company, which are set forth on the reverse side hereof and are hereby certified to be in full force and effect on the date hereof, does hereby nominate, constitute and appoint **William SYRKIN, Rebecca HAAS-BATES and Sergio D. BECHARA, all of Irvine, California, EACH** its true and lawful agent and Attorney-in-Fact, to make, execute, seal and deliver, for, and on its behalf as surety, and as its act and deed: **any and all bonds and undertakings**, and the execution of such bonds or undertakings in pursuance of these presents, shall be as binding upon said Company as fully and amply to all intents and purposes, as if they had been duly executed and acknowledged by the regularly elected officers of the Company at its office in Baltimore, Md., in their own proper persons. This power of attorney revokes that issued on behalf of William SYRKIN, Rebecca HAAS-BATES, Sergio D. BECHARA, Leonard E. ZIMINSKY, dated April 8, 2008.

The said Assistant Secretary does hereby certify that the extract set forth on the reverse side hereof is a true copy of Article VI, Section 2, of the By-Laws of said Company, and is now in force.

IN WITNESS WHEREOF, the said Vice-President and Assistant Secretary have hereunto subscribed their names and affixed the Corporate Seal of the said FIDELITY AND DEPOSIT COMPANY OF MARYLAND, this 25th day of September, A.D. 2009.

ATTEST:

FIDELITY AND DEPOSIT COMPANY OF MARYLAND



Gregory E. Murray

William J. Mills

Gregory E. Murray Assistant Secretary

By:

William J. Mills

William J. Mills Vice President

State of Maryland }
City of Baltimore } ss:

On this 25th day of September, A.D. 2009, before the subscriber, a Notary Public of the State of Maryland, duly commissioned and qualified, came WILLIAM J. MILLS, Vice President, and GREGORY E. MURRAY, Assistant Secretary of the FIDELITY AND DEPOSIT COMPANY OF MARYLAND, to me personally known to be the individuals and officers described in and who executed the preceding instrument, and they each acknowledged the execution of the same, and being by me duly sworn, severally and each for himself deposed and saith, that they are the said officers of the Company aforesaid, and that the seal affixed to the preceding instrument is the Corporate Seal of said Company, and that the said Corporate Seal and their signatures as such officers were duly affixed and subscribed to the said instrument by the authority and direction of the said Corporation.

IN TESTIMONY WHEREOF, I have hereunto set my hand and affixed my Official Seal the day and year first above written.



Maria D. Adamski

Maria D. Adamski

Notary Public

My Commission Expires: July 8, 2011

* Proposal For the Construction of
Rubidoux, Area II Street and Storm
Drain Improvement Project
Project Address: Area bounded by
Wallace Street, 34th Street, Crestmore
Road and Mission Boulevard



ALL AMERICAN ASPHALT

P.O. BOX 2229
CORONA, CA 92878-2229

TO: The Redevelopment Agency for the County of
Riverside
Clerk of the Board of Directors
1st Floor, 4080 Lemon St.
Riverside, CA 92501

RETURN REQUESTED

SEALID BID RECEIVED
CLERK OF THE BOARD OF SUPERVISORS

RECEIVED BY VENDOR - JUNE
TEMP. RECEIVED BY 11:50 A

2011 JUN -6 PM 1:52

CONTRACTOR'S PROPOSAL

TO THE GOVERNING BOARD OF
THE REDEVELOPMENT AGENCY

Date 6-6-11
Hillcrest Contracting, Inc.

FOR THE COUNTY OF RIVERSIDE

Bidder

The undersigned, having carefully examined the proposed site and the Plans and Specifications, the Notice Inviting Bids, the Instructions to Bidders, the Agreement Form, the Bond Forms, the General Conditions and the Supplementary General Conditions for the Rubidoux, Area II Street And Storm Drain Improvement Project, hereby proposes and agrees to furnish all tools, equipment, services, apparatus, facilities, transportation, labor and materials necessary to complete the construction in strict conformity with the Plans and Specifications, including all work specified in Addenda numbered and dated:

Addendum No. 1 Date 5/2/11
 Addendum No. 2 Date 5/19/11
 Addendum No. 3 Date 5/26/11
 Addendum No. 4 Date 6/1/11

for the total sum, including all applicable taxes, permits and licenses as follows:

Item No.	Description	Unit	Estimated Quantity	Unit Prices (In figures) Dollars/Cents	Item Total (In figures) Dollars/Cents
1	Mobilization	LS	1	165,000 ⁰⁰	165,000 ⁰⁰
2	Storm Water Pollution Prevention Plan and NOI	LS	1	45,000 ⁰⁰	45,000 ⁰⁰
3	Not Used				
4	Clearing and Grubbing	LS	1	18,000 ⁰⁰	18,000 ⁰⁰
5	Traffic Control	LS	1	31,000 ⁰⁰	31,000 ⁰⁰
6	Not Used				
7	Signing and Striping	LS	1	14,000 ⁰⁰	14,000 ⁰⁰
8	Develop Water Supply	LS	1	3,000 ⁰⁰	3,000 ⁰⁰
9	Roadway Excavation	CY	18,148	27.00	489,996.00

Item No.	Description	Unit	Estimated Quantity	Unit Prices (in figures) Dollars/Cents	Item Total (in figures) Dollars/Cents
10	Place AC Pavement (See Street Improvement Plan Sht 2 for Course Thickness)	TON	7,600	82.50	627,000.00
11	Place Aggregate Base	CY	7,700	27.50	211,750.00
12	Fog Seal	SF	407,000	0.05	20,350.00
13	Construct 6" Type A-6 Curb and Gutter	LF	13,200	19.00	250,800.00
14	Construct 4" Sidewalk	SF	76,000	3.80	288,800.00
15	Construct Driveway Approach	SF	48,000	4.30	206,400.00
16	Construct Access Ramp	EA	38	2400.00	91,200.00
17	Adjust MH Cover to Grade	EA	43	440.00	18,920.00
18	Adjust Valve Cover to Grade	EA	74	172.00	12,728.00
19	Remove Existing Catch Basin	EA	3	2,000.00	6,000.00
20	Cold Plane 0.1' Existing Pavement	SF	42,000	0.36	15,120.00
21	Construct 0.1' AC Overlay	SY	7,500	6.60	49,500.00
22	Construct Cross Gutter, Spandrel and Curb Return	SF	4,250	7.70	32,725.00
23	Not Used				
24	Remove Existing AC and Base	CY	6,000	23.00	138,000.00
25	Remove Existing Tree	EA	91	570.00	51,870.00
26	Remove Existing Curb or Conc. as Noted	LF	500	9.30	4,650.00

Item No.	Description	Unit	Estimated Quantity	Unit Prices (in figures) Dollars/Cents	Item Total (in figures) Dollars/Cents
27	Remove Existing Guard Post	EA	14	90 ⁰⁰	1,260 ⁰⁰
28	Relocate Existing Sign and Post	EA	43	156 ⁰⁰	6,708 ⁰⁰
29	Relocate Existing Mailbox with New In-Ground Metal Post	EA	250	426 ⁰⁰	106,500 ⁰⁰
30	Not Used			—	—
31	Relocate Existing Drain	EA	2	4040 ⁰⁰	8080 ⁰⁰
32	Relocate Private Lamp	EA	1	3000 ⁰⁰	3000 ⁰⁰
33	Reconstruct In-Kind Exist. Private Owner Block Wall	LF	200	150 ⁰⁰	30,000 ⁰⁰
34	Relocate Exist. Private Owner Chain Link Fence, Recycle Material	LF	4,000	32.50 23.00 38⁰⁰	150,000⁰⁰ 92,000 ⁰⁰ 152,000⁰⁰
35	Reconstruct In-Kind Exist. Private Owner Wood Fence	LF	400	41.00 48.50	16,400 ⁰⁰ 19,400 ⁰⁰
36	Reconstruct In-Kind Exist. Private Owner Wrought Iron Fence, Recycle Panels with New Posts	LF	500	30.00 38⁰⁰	15,000 ⁰⁰ 19,000 ⁰⁰
37	Abandon Existing Backflow Preventer to RCSD Standards	EA	1	1600.00	1600.00
38	Adjust to Grade Existing Vault	EA	1	1350 ⁰⁰	1,350 ⁰⁰
39	Construct Desilting Drain Inlet	EA	4	4,900 ⁰⁰	4,900⁰⁰ 19,600 ⁰⁰
40	Install Type "F" Markers	EA	4	65 ⁰⁰	260 ⁰⁰
41	Relocate Existing Fire Hydrant per RCSD Std. W1050 and Detail Sht 3	EA	20	2,100 ⁰⁰	42,000 ⁰⁰

Item No.	Description	Unit	Estimated Quantity	Unit Prices (in figures) Dollars/Cents	Item Total (in figures) Dollars/Cents
42	Relocate Existing Water Meter per RCSD Std. W1100 and Detail Sht 3	EA	280	580 ⁰⁰	162,400 ⁰⁰
43	Not Used			—	—
44	Relocate Existing Irrigation Control Valve	EA	10	1,250 ⁰⁰	12,500 ⁰⁰
45	Const. New Street Lighting Electrical System in accordance with the Rubidoux Area II Electrical Infrastructure Installation Specifications	LS	1	107,000⁰⁰ 140,000 ⁰⁰	107,000⁰⁰ 140,000 ⁰⁰
46	Install 18" RCP (2000-D)	LF	1,237	102 ⁰⁰	126,174 ⁰⁰
47	Install 24" RCP (2000-D)	LF	3,335	127 ⁰⁰	423,545 ⁰⁰
48	Install 36" RCP (1500-D)	LF	577	162 ⁰⁰	93,474 ⁰⁰
49	Install 42" RCP (1200-D)	LF	724	167 ⁰⁰	120,908 ⁰⁰
50	Install 48" RCP (1500-D)	LF	584	178 ⁰⁰	103,952 ⁰⁰
51	Install 60" RCP (1600-D)	LF	233	226 ⁰⁰	52,658 ⁰⁰
52	Install Catch Basin STD 300 W=7'	EA	26	5800 ⁰⁰	150,800 ⁰⁰
53	Install Catch Basin STD 300 W=14'	EA	18	7,700 ⁰⁰	138,600 ⁰⁰
54	Install Catch Basin STD 300 W=22'	EA	1	6,600 ⁰⁰	6,600 ⁰⁰
55	Install Catch Basin STD 302 W=7'	EA	2	6,500 ⁰⁰	13,000 ⁰⁰
56	Install Drop Inlet STD CB110	EA	1	4,800 ⁰⁰	4,800 ⁰⁰

Item No.	Description	Unit	Estimated Quantity	Unit Prices (in figures) Dollars/Cents	Item Total (in figures) Dollars/Cents
57	Construct Manhole Structure STD MH253 #3	EA	1	2,300 ⁰⁰	2,300 ⁰⁰
58	Construct Manhole Structure STD MH254 #4	EA	6	5,400 ⁰⁰	32,400 ⁰⁰
59	Construct Manhole Structure STD MH251 #1	EA	8	4,100 ⁰⁰	32,800 ⁰⁰
60	Construct Modified Manhole Structure STD 251 #1	EA	1	5,000 ⁰⁰	5,000 ⁰⁰
61	Construct Manhole Structure STD MH252 #2	EA	1	4,300 ⁰⁰	4,300 ⁰⁰
62	Construct Manhole Structure STD JS227 #2	EA	3	3,260 ⁰⁰	9,780 ⁰⁰
63	Construct Frame and Cover for Catch Basin STD CB103	EA	1	380 ⁰⁰	380 ⁰⁰
64	Construct Junction Structure STD JS226 #1	EA	1	3,260 ⁰⁰	3,260 ⁰⁰
65	Construct Junction Structure STD JS229 #4	EA	3	2,050 ⁰⁰	6,150 ⁰⁰
66	Construct Transition Structure STD TS303 #3	EA	13	2,000 ⁰⁰	26,000 ⁰⁰
67	Construct Modified Transition Structure STD TS304 #4	EA	1	37,000 ⁰⁰	37,000 ⁰⁰
68	Construct Modified Transition Structure STD TS301 #1	EA	2	5,200 ⁰⁰	10,400 ⁰⁰
69	Construct Modified Transition Structure STD TS301 #1	EA	1	10,300 ⁰⁰	10,300 ⁰⁰
70	Construct 3'x4' RCB per Caltrans STD D-80	LF	4	700 ⁰⁰	2,800 ⁰⁰
71	Construct 3'x5' RCB per Caltrans STD D-80	LF	4	1,000 ⁰⁰	4,000 ⁰⁰

Item No.	Description	Unit	Estimated Quantity	Unit Prices (in figures) Dollars/Cents	Item Total (in figures) Dollars/Cents
72	Construct Headwall Structure per Caltrans STD D-89	EA	1	6,700 ⁰⁰	6,700 ⁰⁰
73	Install Sewer Steel Casing	LF	24	1,100 ⁰⁰	26,400 ⁰⁰
74	Construct Concrete Collar	EA	1	485 ⁰⁰	485 ⁰⁰
75	Concrete Encasement per RCFC M807	EA	12	1,800 ⁰⁰	21,600 ⁰⁰
76	Construct Concrete Bulkhead	EA	1	520 ⁰⁰	520 ⁰⁰
77	Install 2-Sack Slurry Backfill Over Storm Drain with less than 2' Cover	CY	400	70. ⁰⁰	28,000 ⁰⁰
78	Place Storm Drain Bedding and Backfill in Pipe Zone (to 12" over top of pipe). Material to consist of clean plant manufactured sand having a minimum Sand Equivalent of 30 or approved equal.	LS	1	67,000 ⁰⁰	67,000 ⁰⁰
79	Reconstruct Sewer Lateral per RCFC Std. M808	EA	55	3,230 ⁰⁰	177,650⁰⁰
80	Furnish and install Trench Protection in accordance with Cal/OSHA Standards for Trenches greater than 5' Deep	LS	1	20,000 ⁰⁰	20,000 ⁰⁰
81	Const. Type A Retaining Curb per Addendum Detail, as required.	LF	1,800	10 ²⁰	18,360 ⁰⁰

Item No.	Description	Unit	Estimated Quantity	Unit Prices (in figures) Dollars/Cents	Item Total (in figures) Dollars/Cents
82	Const. Type B Retaining Curb per Addendum Detail, as required.	LF	2,600	11. ¹⁰	28,860. ⁰⁰
83	Const. Masonry Retaining Wall per Greenbook Std Plan 618-3 H=3'-4" Max.	SF	4,300	21. ⁰⁰	90,300. ⁰⁰
84	Encase Exist. RCSD Sewer Main and Laterals with 2-sack slurry to RCSD specifications within Street lowering area delineated on Street Improvement Plan Sheet No. 9, 10 and 27	LF	1,100	41. ⁰⁰	45,100. ⁰⁰
85	Const. Under Sidewalk Drain per Riverside Cnty Std No. 309, as required. (Location not Specified)	EA	20	1,850. ⁰⁰	37,000. ⁰⁰
86	Const. Private Drain through Curb per Riverside Cnty Std No. 310 as required. (Location not Specified)	EA	20	250. ⁰⁰	5,000. ⁰⁰
87	Pothole Exist. Utilities as required for Utility Relocation within Street lowering area delineated on Street Improvement Plan Sheet No. 9, 10 and 27	EA	50	750. ⁰⁰	37,500. ⁰⁰
88	Horiz. Sawcut Existing Curb as required for D/W Approach Const.	LF	400	18. ⁰⁰	7,200. ⁰⁰

Item No.	Description	Unit	Estimated Quantity	Unit Prices (in figures) Dollars/Cents	Item Total (in figures) Dollars/Cents
89	Const. 6" AC Berm per Cnty Std No. 212	LF	500	10. ⁴⁰	5,200 ⁰⁰
90	Remove Existing Concrete Sawcut at Removal Limits. Field Verify Removal Limits of All Exist. Residential Driveways with Inspector Prior to Sawcut and Removal	SF	43,000	1. ⁵⁵	66,650 ⁰⁰
91	Remove Exist. Concrete Structure	EA	1	400000	400000
92	Reconstruct In-Kind Exist. Private Owner Wrought Iron and Block Fence as Required, Recycle W.I. Panels	LF	900	116.⁰⁰ 110.00	104,400⁰⁰ 99,000.00
93	Relocate and/or Adjust to Grade Exist. Private Owner Wrought Iron Gate. Recycle Gate and Install New V-Track and Footing, if Required	LF	2,000	86.⁰⁰ 62.00	172,000⁰⁰ 124,000.00
94	Relocate and/or Adjust to Grade Exist. Private Owner Chain Link Gate, Recycle Material	LF	1,400	36.⁰⁰ 13.00	50,400⁰⁰ 18,200.00
95	Relocate and/or Adjust to Grade Exist. Private Owner Wood Gate, Recycle Material	LF	50	50.⁰⁰ 20.50	2,500⁰⁰ 1,025.00
96	Const. Min. 3" AC Paving Over Compacted Native Soil (90% Min.)	SF	3,300	6. ¹⁰	20,130 ⁰⁰
97	Const. 4" PCC Over Compacted Native Soil (90% Min.)	SF	42,000	4. ³⁵	182,700 ⁰⁰

Item No.	Description	Unit	Estimated Quantity	Unit Prices (In figures) Dollars/Cents	Item Total (In figures) Dollars/Cents
98	Const. 4" A.B. or Gravel Surface for Driveway Match-Up Purposes Over Compacted Native Soil (90% Min.)	SF	7,800	3.60	28,080. ⁰⁰
99	Install Traffic Signal Loop to RCTD Standards	EA	4	600. ⁰⁰	2,400. ⁰⁰
100	Adjust Air-Vac to Grade per RCTD Std W1070	EA	3	3,000. ⁰⁰	9,000. ⁰⁰
101	Relocate Exist. Waterline per RCSD Standards as required by street lowering as shown on Sht No. 9, 10, and 27				
A	Relocate Exist. 6" Waterline	LF	650	127. ⁰⁰	82,550. ⁰⁰
B	Relocate Exist. 8" Waterline	LF	75	112. ⁰⁰	8,400. ⁰⁰
C	Relocate Exist. 12" Waterline	LF	250	89. ⁰⁰	22,250. ⁰⁰
102	Underground Unforeseen Conditions Allowance. To be used as approved and directed by Agency. Unused monies to be returned to Agency.	T&M	1	\$150,000	\$150,000
104	Hot Tap and connect to Existing 6" A.C.P. Waterline.	EA	4	2,400. ⁰⁰	9,600. ⁰⁰
105	Hot Tap and connect to Existing 8" D.I.P. Waterline.	EA	2	3,000. ⁰⁰	6,000. ⁰⁰
105	Hot Tap and connect to Existing 12" PVC Waterline.	EA	2	3,350. ⁰⁰	6,700. ⁰⁰
107	Encase Existing 6" A.C.P. Waterline	LF	650	26. ⁰⁰	16,900. ⁰⁰

Item No.	Description	Unit	Estimated Quantity	Unit Prices (in figures) Dollars/Cents	Item Total (in figures) Dollars/Cents
108	Encase Existing 8" D.I.P Waterline	LF	75	26 ⁰⁰	1,950. ⁰⁰
109	Encase Existing 12" PVC Waterline	LF	250	37 ⁰⁰	9,250 ⁰⁰
110	Connect Existing Water Meter to New Water Main.	EA	20	1,300 ⁰⁰	26,000 ⁰⁰

TOTAL SUM BID, ITEMS 1 THROUGH 110: Six Million, Three Hundred
 (Words)
Eighty nine thousand and five hundred eighty (\$ 6,389,508.00)
 (Figures)
 00/100 Dollars

The determination of the low bidder will be based on the Base Bid. Bids must be submitted on all items. Failure to bid on all items may result in the bid being rejected as non-responsive.

DESIGNATION OF SUBCONTRACTORS

In compliance with the Public Contract Code, Sections 4104-4144, the undersigned submits the following complete list of each subcontractor who will perform work or labor or render services in or about the construction in an amount in excess of one-half of 1 percent of said total bid.

PORTION OF THE WORK	SUBCONTRACTOR	ADDRESS
---------------------	---------------	---------

Electrical	SIERRA PACIFIC	Riverside, CA
Fence	Valley Gate	Moreno Valley
MASONRY	MARK WHITAKER	CHINO, CA.
SEWER	SURINA	Bloomington
STORM	Kip Inc.	Murrieta CA.
WATER	SURINA	Bloomington
Electrical	Stacy Co. N	Baldwin Park, CA
Fence	Econo Fence	Riverside, CA.
Electrical	SIERRA PACIFIC	Riverside, CA.

AWARD OF CONTRACT

The undersigned fully understands that a Contract is formed upon the acceptance of this proposal by the Owner, and the undersigned further agrees that upon request he will promptly execute and deliver to Owner a written memorial of the Contract together with the required labor and material and performance bonds.

BID GUARANTEE

The enclosed certified or cashier's check or bidder's bond on approved form, made payable to the Owner, in the amount of ten percent (10%) of the total bid submitted herewith, is hereby given as guarantee that the bidder will execute and deliver the above mentioned written memorial and required bonds if awarded the contract, and in the event that the undersigned fails or refuses to execute and deliver said documents, such check or bond is to be charged with the costs of the damages experienced by the Owner as a result of such failure or refusal, including, but not limited to publication costs, the difference in money between the amount of the bid of the said principal and the amount for which obligee may legally contract with another party to perform the said work if such amount be in excess of the former, building lease or rental costs, transportation costs and additional salary costs that result from the delay due to the principal's default on the awarded contract. In no event, however, shall the Surety's liability exceed the penal sum hereof.

Name of Bidder HILLCREST CONTRACTING, INC.

Type of Organization CORPORATION

Signed By



Title of Signer GLENN J. SALSBURY-PRESIDENT

Address of Bidder 1467 CIRCLE CITY DR. CORONA, CA 92879

Telephone Number (951) 273-9600 FAX (951) 273-9608

Contractor's License 471664

Classification A HAZ

If bidder is a corporation, and signer is not President or Secretary, attach certified copy of Bylaws or resolution authorizing execution. If bidder is a corporation, affix corporate seal. If signer is an agent, attach Power of Attorney. If bidder is not an individual, list names of other persons authorized to bind the organization.

BID BOND

KNOW ALL MEN BY THESE PRESENTS, that we, the undersigned
HILLCREST CONTRACTING, INC.

_____, as Principal : and _____ FIDELITY AND DEPOSIT COMPANY OF MARYLAND
_____, as Surety, are hereby held and firmly bound unto the Redevelopment Agency for
the County of Riverside, hereinafter called the "Owner", in the sum of
** _____ dollars (\$ 10%) for the payment of which sum, well and truly to be
made, were hereby jointly and severally bind ourselves, our heirs, executors,
administrators, successors and assigns.

** TEN PERCENT OF AMOUNT BID

WHEREAS, the said Principal is herewith submitting its proposal for the construction of
Rubidoux, Area II Street And Storm Drain Improvement Project

THE CONDITION OF THE ABOVE OBLIGATION IS SUCH, that if the aforesaid Principal shall be awarded the contract upon said proposal and shall, within the required number of days after the notice of such award, execute a written memorial of the awarded contract and submit the required labor and material and faithful performance bond, then this obligation shall be null and void; and in the event that the principal fails and/or refuses to execute and deliver said documents this bond will be charged with the costs of the damages experienced by the Owner as a result of such refusal, including but not limited to, publication cost, the difference in money between the amount of the bid of the said principal and the amount for which the obligee may legally contract with another party to perform the said work if such amount be in excess of the former; building lease or rental costs, transportation costs, and additional salary costs that result from the delay due to the principal's default on the awarded contract. In no event however, shall the Surety's liability exceed the penal sum hereof.

The Surety, for value received, hereby stipulates and agrees that the obligations of said Surety and its bond shall be in no way impaired or affected by any extension of the time within which the Owner may accept such bid; and said Surety does hereby waive notice of any such extension.

IN WITNESS WHEREOF, the above-bounded parties have executed this instrument under their several seals this 20TH day of APRIL, 2011, the name and corporate seal of each corporate party being hereto affixed and these presents duly signed by its undersigned representative, pursuant to authority of its governing body.

In the presence of:

_____	_____ (Seal)
_____	Individual Principal
_____	_____
Address	Business Address
_____	_____ (Seal)
_____	Individual Principal
_____	_____
Address	Business Address

Attest:

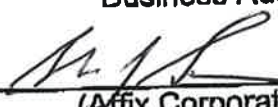

Einer G. Lindholm-V.P./Secretary

HILLCREST CONTRACTING, INC.
Corporate Principal
 1467 CIRCLE CITY DRIVE
 CORONA, CA 92879

 Business Address
 By 
 (Affix Corporate Seal)
Glenn J. Salsbury-President

Attest:

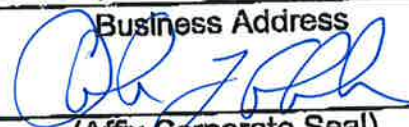
FIDELITY AND DEPOSIT COMPANY OF MARYLAND
Corporate Principal SURETY
 C/O ZURICH 1400 AMERICAN LN.
 SCHAUMBURG, IL 60196

 Business Address
 By 
 (Affix Corporate Seal)
 CHARLES L. FLAKE, ATTORNEY-IN-FACT

The rate of premium on this bond is NIL per thousand. Total amount of premium charged, \$ NIL .

(The above must be filled in by corporate surety.)

CALIFORNIA ALL-PURPOSE ACKNOWLEDGMENT

STATE OF CALIFORNIA

County of Orange }

On 4/20/11 before me, Lexie Sherwood, Notary Public
Date Here Insert Name and Title of the Officer

personally appeared Charles L. Flake
Name(s) of Signer(s)



Place Notary Seal Above

who proved to me on the basis of satisfactory evidence to be the person(s) whose name(s) is/are subscribed to the within instrument and acknowledged to me that he/she/they executed the same in his/her/their authorized capacity(ies), and that by his/her/their signature(s) on the instrument the person(s), or the entity upon behalf of which the person(s) acted, executed the instrument.

I certify under PENALTY OF PERJURY under the laws of the State of California that the foregoing paragraph is true and correct.

Witness my hand and official seal.

Signature Lexie Sherwood
Signature of Notary Public

OPTIONAL

Though the information below is not required by law, it may prove valuable to persons relying on the document and could prevent fraudulent removal and reattachment of this form to another document.

Description of Attached Document

Title or Type of Document: _____

Document Date: _____ Number of Pages: _____

Signer(s) Other Than Named Above: _____

Capacity(ies) Claimed by Signer(s)

Signer's Name: _____

- Individual
- Corporate Officer — Title(s): _____
- Partner — Limited General
- Attorney in Fact
- Trustee
- Guardian or Conservator
- Other: _____

RIGHT THUMBPRINT OF SIGNER

Top of thumb here

Signer Is Representing:

Signer's Name: _____

- Individual
- Corporate Officer — Title(s): _____
- Partner — Limited General
- Attorney in Fact
- Trustee
- Guardian or Conservator
- Other: _____

RIGHT THUMBPRINT OF SIGNER

Top of thumb here

Signer Is Representing:

CALIFORNIA ALL PURPOSE ACKNOWLEDGMENT

State of California
County of Riverside

ON May 2, 2011, before me, A. Crombach, Notary Public, personally appeared Glenn Salsbury and Einer G. Lindholm, who proved to me on the basis of satisfactory evidence to be the persons whose name(s) are subscribed to the within instrument and acknowledged to me that they executed the same in their authorized capacities, and that by their signatures(s) on the instrument the persons, or the entity upon behalf of which the persons acted, executed the instrument.

I certify under PENALTY OF PERJURY under the laws of the state of California that the foregoing is true and correct.

Witness my hand and official seal

A. Crombach

A. Crombach, Notary Public

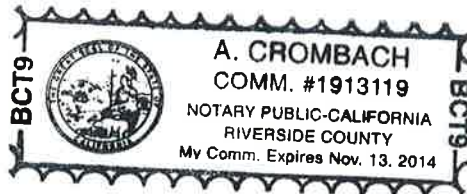

OPTIONAL

Though law does not require the information below, it may prove valuable to persons relying on the document and could prevent fraudulent removal of this form to another document.

Description of Attached Document

Title or type of Document Bid Bond

Document Date: _____

Number of Pages: _____

Signer(s) Other Than Named Above _____

Capacity(ies) Claimed by Signer

Signer's Name:

Individual

- Corporate Officer – Title(s): President & Vice President/ Secretary
- Partner - Limited General
- Attorney in Fact
- Trustee
- Guardian or Conservator
- Other:

Signer is Representing: Hillcrest Contracting, Inc

EXTRACT FROM BY-LAWS OF FIDELITY AND DEPOSIT COMPANY OF MARYLAND

"Article VI, Section 2. The Chairman of the Board, or the President, or any Executive Vice-President, or any of the Senior Vice-Presidents or Vice-Presidents specially authorized so to do by the Board of Directors or by the Executive Committee, shall have power, by and with the concurrence of the Secretary or any one of the Assistant Secretaries, to appoint Resident Vice-Presidents, Assistant Vice-Presidents and Attorneys-in-Fact as the business of the Company may require, or to authorize any person or persons to execute on behalf of the Company any bonds, undertakings, recognizances, stipulations, policies, contracts, agreements, deeds, and releases and assignments of judgements, decrees, mortgages and instruments in the nature of mortgages,....and to affix the seal of the Company thereto."

CERTIFICATE

I, the undersigned, Assistant Secretary of the FIDELITY AND DEPOSIT COMPANY OF MARYLAND, do hereby certify that the foregoing Power of Attorney is still in full force and effect on the date of this certificate; and I do further certify that the Vice-President who executed the said Power of Attorney was one of the additional Vice-Presidents specially authorized by the Board of Directors to appoint any Attorney-in-Fact as provided in Article VI, Section 2, of the By-Laws of the FIDELITY AND DEPOSIT COMPANY OF MARYLAND.

This Power of Attorney and Certificate may be signed by facsimile under and by authority of the following resolution of the Board of Directors of the FIDELITY AND DEPOSIT COMPANY OF MARYLAND at a meeting duly called and held on the 10th day of May, 1990.

RESOLVED: "That the facsimile or mechanically reproduced seal of the company and facsimile or mechanically reproduced signature of any Vice-President, Secretary, or Assistant Secretary of the Company, whether made heretofore or hereafter, wherever appearing upon a certified copy of any power of attorney issued by the Company, shall be valid and binding upon the Company with the same force and effect as though manually affixed."

IN TESTIMONY WHEREOF, I have hereunto subscribed my name and affixed the corporate seal of the said Company,

this 20TH day of APRIL, 2011.



Assistant Secretary

**Power of Attorney
FIDELITY AND DEPOSIT COMPANY OF MARYLAND**

KNOW ALL MEN BY THESE PRESENTS: That the FIDELITY AND DEPOSIT COMPANY OF MARYLAND, a corporation of the State of Maryland, by WILLIAM J. MILLS, Vice President, and ERIC D. BARNES, Assistant Secretary, in pursuance of authority granted by Article VI, Section 2, of the By-Laws of said Company, which are set forth on the reverse side hereof and are hereby certified to be in full force and effect on the date hereof, does hereby nominate, constitute and appoint **Richard A. COON, Charles L. FLAKE, David L. CULBERTSON and Lexie SHERWOOD, all of Anaheim, California, EACH** its true and lawful agent and Attorney-in-Fact, to make, execute, seal and deliver, for, and on its behalf as surety, and as its act and deed: ~~any and all bonds and undertakings, and the execution of such bonds or undertakings in pursuance of these presents, shall be as binding upon said Company, as fully and amply, to all intents and purposes, as if they had been duly executed and acknowledged by the regularly elected officers of the Company at its office in Baltimore, Md., in their own proper persons.~~ This power of attorney revokes that issued on behalf of Richard A. COON, Charles L. FLAKE, David L. CULBERTSON, Matthew P. FLAKE, Lexie SHERWOOD, dated November 7, 2005.

The said Assistant Secretary does hereby certify that the extract set forth on the reverse side hereof is a true copy of Article VI, Section 2, of the By-Laws of said Company, and is now in force.

IN WITNESS WHEREOF, the said Vice-President and Assistant Secretary have hereunto subscribed their names and affixed the Corporate Seal of the said FIDELITY AND DEPOSIT COMPANY OF MARYLAND, this 15th day of November, A.D. 2006.

ATTEST:

FIDELITY AND DEPOSIT COMPANY OF MARYLAND



Eric D. Barnes

Eric D. Barnes Assistant Secretary

William J. Mills

By: *William J. Mills* Vice President

State of Maryland }
City of Baltimore } ss:

On this 15th day of November, A.D. 2006, before the subscriber, a Notary Public of the State of Maryland, duly commissioned and qualified, came WILLIAM J. MILLS, Vice President, and ERIC D. BARNES, Assistant Secretary of the FIDELITY AND DEPOSIT COMPANY OF MARYLAND, to me personally known to be the individuals and officers described in and who executed the preceding instrument, and they each acknowledged the execution of the same, and being by me duly sworn, severally and each for himself depose and saith, that they are the said officers of the Company aforesaid, and that the seal affixed to the preceding instrument is the Corporate Seal of said Company, and that the said Corporate Seal and their signatures as such officers were duly affixed and subscribed to the said instrument by the authority and direction of the said Corporation.

IN TESTIMONY WHEREOF, I have hereunto set my hand and affixed my Official Seal the day and year first above written.



Constance A. Dunn

Constance A. Dunn Notary Public
My Commission Expires: July 14, 2011

NON-COLLUSION AFFIDAVIT

TO BE EXECUTED BY BIDDER AND SUBMITTED WITH BID

STATE OF CALIFORNIA }
COUNTY OF RIVERSIDE } SS

GLENN J. SALSBURY, being first duly sworn, deposes and says:

That he or she is PRESIDENT of HILLCREST CONTRACTING, INC.

the party making the foregoing bid; that the bid is not made in the interest of, or on behalf of, any undisclosed person, partnership, company, association, organization, or corporation; that the bid is genuine and not collusive or sham; that the bidder has not directly or indirectly induced or solicited any other bidder to put in a false or sham bid, and has not directly or indirectly colluded, conspired, connived, or agreed with any bidder or anyone else to put in a sham bid, or that anyone shall refrain from bidding; that the bidder has not in any manner, directly or indirectly, sought by agreement, communication, or conference with anyone to fix the bid price of the bidder or any other bidder, or to fix any overhead, profit, or cost element of the bid price, or of that of any other bidder, or to secure any advantage against the public body awarding the contract of anyone interested in the proposed contract; that all statements contained in the bid are true; and, further, that the bidder has not, directly or indirectly, submitted his or her bid price or any breakdown thereof, or the contents thereof, or divulged information or data relative thereto, or paid, and will not pay, any fee to any depository, or to any member or agent thereof to effectuate a collusive or sham bid.

Signature GLENN J. SALSBURY-PRESIDENT

Subscribed and sworn to before me this _____ day of _____, 200_____

Signature of Officer Administering Oath

JURAT

State of California
County of Riverside

Subscribed and sworn to (or affirmed) before me
The 2nd day of May 2011 by,
Glenn Salsbury

proved to me on the basis of satisfactory evidence to be the
person(s) who appeared before me.

Signature: _____

A. Crombach

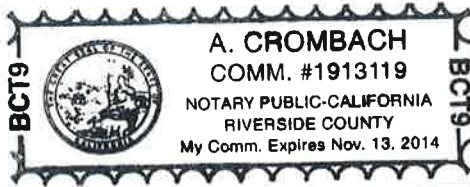

A. Crombach, Notary Public

OPTIONAL

Though the information below is not required by law, it may prove valuable to persons relying on the document and could prevent fraudulent removal of this form to another document.

Description of Attached Document: Non Collusion Affidavit

Document Date: _____ Pages: _____

Signer(s) Other Than Named Above None

**CONTRACTOR'S CERTIFICATE REGARDING
WORKER'S COMPENSATION INSURANCE**

Section 3700 of the Labor Code provides, in part, as follows:

"Every employer except the State and all political subdivision or institutions thereof, shall secure the payment of compensation in one (1) or more of the following ways:

- a) by being insured against liability to pay compensation with one (1) or more insurers duly authorized to write compensation insurance in this State; or
- b) by securing from the Director of Industrial Relations, a Certificate of Consent to Self-insure, which may be given upon furnishing proof satisfactory to the Director of Industrial Relations of ability to self-insure and to pay any compensation that may become due to his employees ..."

The undersigned is aware of the provisions of Section 3700 of the Labor Code that requires every employer to be insured against liability for Worker's Compensation or to undertake self-insurance in accordance with the provisions of that Code, and will comply with such provisions before commencing the performance of the work of this Contract.

Signature:  Date: 4/26/11
Printed Name: GLENN J. SALSBURY Title: PRESIDENT
Company: HILLCREST CONTRACTING, INC.
Address: 1467 CIRCLE CITY DR. CORONA, CA 92879

(In accordance with Article 5 [commencing at Section 1860], Chapter 1, Part 7, Division 2, of the Labor Code, the above Certificate must be signed by Contractor and filed with the awarding body prior to Contractor performing any work under this Contract.)

CONTRACTOR'S CERTIFICATE REGARDING
WORKER'S COMPENSATION INSURANCE

SEALED BID RECEIVED
CLERK OF THE BOARD OF SUPERVISORS

RECEIVED RIVERSIDE COUNTY
CLERK / BOARD OF SUPERVISORS

2011 JUN -6 PM 3:55

License #471664A

HILLCREST CONTRACTING

General Engineering Contractors

P.O. Box 1898 • Corona, CA 92878-1898

To:

CO. OF RIVERSIDE REDEVELOPMENT AGENCY
CLERK OF THE BOARD OF DIRECTORS
COUNTY ADMINISTRATIVE CENTER 1ST FLOOR
4080 LEMON ST.
RIVERSIDE, CA 92501

PROPOSAL FOR THE CONSTRUCTION OF:
RUBIDOUX AREA II STREET & STORM DRAIN
IMPROVEMENT PROJECT PROJECT ADDRESS:
AREA BOUNDED BY WALLACE ST, 34TH ST,

NOTICE INVITING BIDS

The Redevelopment Agency for the County of Riverside, herein called Owner, invites sealed proposals for the construction of:

Rubidoux, Area II Street And Storm Drain Improvement Project

Project Address:

Area bounded by Wallace Street, 34th Street,
Crestmore Road and Mission Boulevard.

Proposals shall be delivered to the Clerk of the Board of Directors, on the 1st floor of the County Administrative Center located at 4080 Lemon Street, 1st Floor, Riverside, CA 92501, not later than 2:00 p.m. ~~11/11~~, on June 6, 2010 to be promptly opened in public at said address.

Each proposal shall be in accordance with Plans, Specifications and other Contract Documents dated 10-06 and 3-11 and prepared by Pettit, Inc., whose address is 1641 Commerce Street, Corona, CA 92880, (951) 736-8161. The Plans, Specifications, and other Contract Documents can be reviewed at <http://dfs.aandirepro.com> and purchased by calling A&I Reprographics at (800) 233-8435. There will be a non-refundable charge per set. Bidders requesting that sets be mailed or shipped to them will be charged the full cost of shipping. Please make checks payable to A&I Reprographics, not the Redevelopment Agency for the County of Riverside.

Pursuant to the Labor Code, the Governing Board of the Owner has obtained from the Director of Industrial Relations, State of California, his determinations of general prevailing rates of per diem wages applicable to the work, and for holiday and overtime work, including employee payments or health and welfare, pension, vacation and similar purposes, as set forth on schedule which is on file at the principal office of the Owner, and which will be made available to any interested person upon request.

The Contract General Conditions for this project will contain provisions allowing successful contractor to substitute securities for monies withheld by the Owner to ensure performance (Public Contract Code 22300).

A Performance Bond and Payment Bond shall be required for this project.

The Contractor will be required, per Public Contracts Code, Section 3300 and for this contract, to have a State of California contractor's license classification A – General Engineering Contractor. A mandatory pre-bid job walk inspection will be held on April 25, 2010 at 8.30 a.m., meeting Riverside, CA.

No bids will be accepted from bidders who have not attended the pre-bid job walk.

For Further information, contact Delia Flores at the Redevelopment Agency for the County of Riverside located at 3403 10th Street, Suite 500, Riverside CA 92501 whose phone number is (951) 955-5737.

RIVERSIDE CONSTRUCTION CO.
4225 GARNER RD.
P.O. BOX 1140
RIVERSIDE, CA 92502

REDEVELOPMENT AGENCY FOR THE COUNTY OF RIVERSIDE

Kecia Harper-Ihem, Clerk

By: _____
Deputy

Dated:

INSTRUCTIONS TO BIDDERS

- A. **COMMUNICATION:** All communication **will be in writing**, no phone calls or other verbal communication will be allowed.

Bidders may submit questions or request clarifications of any aspect of the proposal process or proposed construction on the form provided titled "Request for Information" (RFI). RFI's may be faxed, mailed or delivered to the person designated as the contact. All RFI's and the Owner's answers to RFI's will be compiled, faxed and mailed to all registered bidders as soon as possible. To be considered, all RFI's shall be submitted in writing by 5:00 p.m. a minimum of **ten (10) working days** prior to bid date. The person submitting the request will be responsible for its prompt delivery.

All requests shall be submitted as single RFI's for one particular question or subject. Multiple requests per form may or may not be considered at the discretion of the Owner or Owner's representative.

- B. **DRAWINGS AND SPECIFICATIONS:** All drawings, herein enclosed, become a part of the Bid Documents. Additional sets may be provided if requested by bidders and deemed necessary and if there is sufficient time. Sets may be purchased by calling A&I Reprographics at (800) 233-8435. There will be a non-refundable charge per set. Bidders requesting that sets be mailed or shipped to them will be charged the full cost of shipping. Please make checks payable to A&I Reprographics, not the Redevelopment Agency for the County of Riverside.
- C. **FORM OF THE PROPOSAL:** The proposal must be made on the attached Contractors Proposal form, which must be filled out completely, dated and signed by the bidder or duly authorized agent in accordance with the directions on the Proposal form.

Each proposal shall include a complete list of the subcontractors proposed for every portion of the work, in accordance with Public Contract Code Sections 4100 - 4114, inclusive.

- D. **SUBMISSION OF PROPOSAL:** Signed copies of each Proposal shall be sealed in an opaque envelope. The envelope shall bear the bidders name and shall be marked:

***PROPOSAL FOR THE CONSTRUCTION OF
Rubidoux, Area II Street And Storm Drain Improvement Project**

**Project Address:
Area bounded by Wallace Street, 34th Street,
Crestmore Road and Mission Boulevard.**

Proposals shall be submitted at the place designated in the Notice Inviting Bids at, or before, the time specified in said Notice. Before that time a proposal may be withdrawn, but only in person by the bidder or someone authorized by him in writing, and not by telephone or telegram.

- E. **INTERPRETATION OF THE DOCUMENTS:** Discrepancies in and omissions from the plans, specifications or other contract documents, or questions as to their meaning shall, at once, be brought to the attention of the Owner. Any interpretation of the documents will be made only by addenda duly issued and a copy of such addenda will be mailed or delivered to each person or firm receiving a set of such documents. The Owner will not be responsible for any other explanations or interpretations. Should

anything in the scope of the work or any of the sections of the specifications be of such nature as to be apt to cause disputes between the various trades involved, such information shall be promptly called to the attention of the Owner.

- F. **ADDENDA TO THE DOCUMENTS:** The Owner reserves the right to issue such addenda to the documents as it may desire at any time prior to the time fixed for receiving proposals. A copy of all such addenda will be promptly mailed or delivered to each bidder. The number and date of each addendum shall be listed on the Contractors Proposal in the space provided.
- G. **OWNERS RESERVATION OF RIGHTS:** The Owner reserves the right to reject any or all proposals and to waive any informalities in a bid or in the bidding. No bidder may withdraw his bid for a period of sixty (60) days after the time set or the opening thereof.
- H. **BIDDERS CHECK OR BOND:** Each proposal must be accompanied by a certified or cashier's check, or by a bid bond on the form supplied by the Owner, drawn in favor of the Owner in an amount not less than ten percent (10%) of the total proposal. This check or bond shall be given as a guarantee that the bidder, if awarded the contract, will execute and deliver the contract documents and the required Payment & Performance bonds in accordance with his proposal accepted by the Owner.

In default of execution of the contract upon award and/or delivery of said Payment and Performance Bonds, such proposal bond or check shall be held subject to payment to the Owner of the difference in money between the amount of the bidders proposal and the amount for which the Owner may legally contract with another party to perform the said work together with the costs to the Owner of redrafting, redrawing and publishing documents and papers necessary to obtain new bids on the said work. The check or bond shall, in addition, be held subject to all other damages suffered by the Owner, as set forth in the contract documents. Said check or bond will be returned upon the close of the period mentioned in Paragraph G above, and to the successful bidder upon execution of the contract documents.

NO BONDS WILL BE ACCEPTED UNLESS SUBMITTED ON FORM SUPPLIED BY OWNER.

- I. **AWARD OF CONTRACT:** The contract shall be awarded upon a resolution or minute order to that effect duly adopted by the governing board of the Owner. Execution of the contract documents shall constitute a written memorial thereof.
- J. **ADDITIONAL INFORMATION:** The Owner reserves the right to require of a bidder information regarding financial responsibility or such other information as the Owner determines is necessary to ascertain whether a bid is in fact the lowest responsible bid submitted. All references to an Architect shall be deemed to refer to the Owner where no Architect has been employed by the Owner.
- K. **PROMPT ACTION BY CONTRACTOR:** After the award of the Contract by the Owner, and within four (4) days after the Agreement Forms are presented to the Contractor for signing, he shall return to the Owner the signed Agreements, along with all necessary Bonds and Certificates of Insurance.
- L. **CAUTION TO BIDDERS:** Prospective bidders are cautioned not to merely examine the plans and specifications in making their bid, since requirements are imposed upon the contractor by various other portions of the Contract Documents.
- M. **PERFORMANCE AND PAYMENTS BONDS:** Bidders attention is directed to the

requirement that both the Performance and Payment Bonds are one hundred percent (100%) of the contract price.

- N. **BIDDERS QUALIFICATIONS:** To be considered, a potential bidder must have an A License, as required under provisions of Public Contracts Code Section 3300, and the California Business and Professions Code, for work covered in its proposal when a bid is submitted. This includes a joint venture formed to submit a bid.
- O. **TIME OF COMPLETION:** Time of completion of project is two hundred ten (210) calendar days from the date specified in the NOTICE TO PROCEED issued by the Owner.
- P. **BIDS:** Under the bidding items listed on Contractors Proposal, bidders shall state prices for each basis for bid given herein after:
 - 1. Base Bid shall be the entire work complete in accordance with the drawings and specifications.

CONTRACTOR'S PROPOSAL

TO THE GOVERNING BOARD OF
 THE REDEVELOPMENT AGENCY

Date June 3, 2011

Riverside Construction Company, Inc.

FOR THE COUNTY OF RIVERSIDE

Bidder

The undersigned, having carefully examined the proposed site and the Plans and Specifications, the Notice Inviting Bids, the Instructions to Bidders, the Agreement Form, the Bond Forms, the General Conditions and the Supplementary General Conditions for the Rubidoux, Area II Street And Storm Drain Improvement Project, hereby proposes and agrees to furnish all tools, equipment, services, apparatus, facilities, transportation, labor and materials necessary to complete the construction in strict conformity with the Plans and Specifications, including all work specified in Addenda numbered and dated:

Addendum No. 1 Date 5/2/2011
 Addendum No. 2 Date 5/19/2011
 Addendum No. 3 Date 5/23/2011
 Addendum No. 4 Date 6/1/2011

for the total sum, including all applicable taxes, permits and licenses as follows:

Item No.	Description	Unit	Estimated Quantity	Unit Prices (in figures) Dollars/Cents	Item Total (in figures) Dollars/Cents
1	Mobilization	LS	1	400,000 ⁰⁰	400,000 ⁰⁰
2	Storm Water Pollution Prevention Plan and NOI	LS	1	72,000 ⁰⁰	72,000 ⁰⁰
3	Not Used			—	—
4	Clearing and Grubbing	LS	1	25000 ⁰⁰	25000 ⁰⁰
5	Traffic Control	LS	1	155,000 ⁰⁰	155,000 ⁰⁰
6	Not Used			—	—
7	Signing and Striping	LS	1	15,000 ⁰⁰	15,000 ⁰⁰
8	Develop Water Supply	LS	1	60,000 ⁰⁰	60,000 ⁰⁰
9	Roadway Excavation	CY	18,148	1 ⁰⁰	18148 ⁰⁰

RIVERSIDE CONSTRUCTION CO.
 4225 GARNER RD.
 P.O. BOX 1146
 RIVERSIDE, CA 92502

Item No.	Description	Unit	Estimated Quantity	Unit Prices (in figures) Dollars/Cents	Item Total (in figures) Dollars/Cents
10	Place AC Pavement (See Street Improvement Plan Sht 2 for Course Thickness)	TON	7,600	72 ⁰⁰	547,200 ⁰⁰
11	Place Aggregate Base	CY	7,700	30 ⁰⁰	231,000 ⁰⁰
12	Fog Seal	SF	407,000	0. ⁰⁰	24420 ⁰⁰
13	Construct 6" Type A-6 Curb and Gutter	LF	13,200	17 ⁰⁰	224,400 ⁰⁰
14	Construct 4" Sidewalk	SF	76,000	3. ²⁵	247,000 ⁰⁰
15	Construct Driveway Approach	SF	48,000	5 ⁰⁰	240,000 ⁰⁰
16	Construct Access Ramp	EA	38	1900 ⁰⁰	72,200 ⁰⁰
17	Adjust MH Cover to Grade	EA	43	550 ⁰⁰	23,650 ⁰⁰
18	Adjust Valve Cover to Grade	EA	74	300 ⁰⁰	22,200 ⁰⁰
19	Remove Existing Catch Basin	EA	3	1200 ⁰⁰	3,600 ⁰⁰
20	Cold Plane 0.1' Existing Pavement	SF	42,000	0. ³⁰	12,600 ⁰⁰
21	Construct 0.1' AC Overlay	SY	7,500	5 ⁰⁰	37,500 ⁰⁰
22	Construct Cross Gutter, Spandrel and Curb Return	SF	4,250	8 ⁰⁰	34,000 ⁰⁰
23	Not Used			—	—
24	Remove Existing AC and Base	CY	6,000	22 ⁰⁰	132,000 ⁰⁰
25	Remove Existing Tree	EA	91	530 ⁰⁰	48,230 ⁰⁰
26	Remove Existing Curb or Conc. as Noted	LF	500	4. ⁵⁰	2,250 ⁰⁰

Item No.	Description	Unit	Estimated Quantity	Unit Prices (in figures) Dollars/Cents	Item Total (in figures) Dollars/Cents
27	Remove Existing Guard Post	EA	14	135 ⁰⁰	1890 ⁰⁰
28	Relocate Existing Sign and Post	EA	43	350 ⁰⁰	15050 ⁰⁰
29	Relocate Existing Mailbox with New In-Ground Metal Post	EA	250	200 ⁰⁰	50000 ⁰⁰
30	Not Used			_____	_____
31	Relocate Existing Drain	EA	2	750 ⁰⁰	1500 ⁰⁰
32	Relocate Private Lamp	EA	1	2500 ⁰⁰	2500 ⁰⁰
33	Reconstruct In-Kind Exist. Private Owner Block Wall	LF	200	210 ⁰⁰	42000 ⁰⁰
34	Relocate Exist. Private Owner Chain Link Fence, Recycle Material	LF	4,000	35 ⁰⁰	140,000 ⁰⁰
35	Reconstruct In-Kind Exist. Private Owner Wood Fence	LF	400	35 ⁰⁰	14000 ⁰⁰
36	Reconstruct In-Kind Exist. Private Owner Wrought Iron Fence, Recycle Panels with New Posts	LF	500	35 ⁰⁰	17500 ⁰⁰
37	Abandon Existing Backflow Preventer to RCSD Standards	EA	1	5000 ⁰⁰	5000 ⁰⁰
38	Adjust to Grade Existing Vault	EA	1	1300 ⁰⁰	1300 ⁰⁰
39	Construct Desilting Drain Inlet	EA	4	1800 ⁰⁰	7200 ⁰⁰
40	Install Type "F" Markers	EA	4	50 ⁰⁰	200 ⁰⁰
41	Relocate Existing Fire Hydrant per RCSD Std. W1050 and Detail Sht 3	EA	20	2200 ⁰⁰	44000 ⁰⁰

RIVERSIDE CONSTRUCTION CO.
 4225 GARNER RD.
 P.O. BOX 1146
 RIVERSIDE, CA 92502

Item No.	Description	Unit	Estimated Quantity	Unit Prices (in figures) Dollars/Cents	Item Total (in figures) Dollars/Cents
42	Relocate Existing Water Meter per RCSD Std. W1100 and Detail Sht 3	EA	280	550 ⁰⁰	154000 ⁰⁰
43	Not Used			_____	_____
44	Relocate Existing Irrigation Control Valve	EA	10	350 ⁰⁰	3500 ⁰⁰
45	Const. New Street Lighting Electrical System in accordance with the Rubidoux Area II Electrical Infrastructure Installation Specifications	LS	1	140,000 ⁰⁰	140,000 ⁰⁰
46	Install 18" RCP (2000-D)	LF	1,237	152 ⁰⁰	188024 ⁰⁰
47	Install 24" RCP (2000-D)	LF	3,335	125 ⁰⁰	416875 ⁰⁰
48	Install 36" RCP (1500-D)	LF	577	125 ⁰⁰	72125 ⁰⁰
49	Install 42" RCP (1200-D)	LF	724	180 ⁰⁰	130320 ⁰⁰
50	Install 48" RCP (1500-D)	LF	584	185 ⁰⁰	108040 ⁰⁰
51	Install 60" RCP (1600-D)	LF	233	245 ⁰⁰	57085 ⁰⁰
52	Install Catch Basin STD 300 W=7'	EA	26	6500 ⁰⁰	169000 ⁰⁰
53	Install Catch Basin STD 300 W=14'	EA	18	8000 ⁰⁰	144000 ⁰⁰
54	Install Catch Basin STD 300 W=22'	EA	1	10500 ⁰⁰	10500 ⁰⁰
55	Install Catch Basin STD 302 W=7'	EA	2	6500 ⁰⁰	13000 ⁰⁰
56	Install Drop Inlet STD CB110	EA	1	12000 ⁰⁰	12000 ⁰⁰

Item No.	Description	Unit	Estimated Quantity	Unit Prices (in figures) Dollars/Cents	Item Total (in figures) Dollars/Cents
57	Construct Manhole Structure STD MH253 #3	EA	1	2400 ⁰⁰	2400 ⁰⁰
58	Construct Manhole Structure STD MH254 #4	EA	6	9200 ⁰⁰	55200 ⁰⁰
59	Construct Manhole Structure STD MH251 #1	EA	8	4500 ⁰⁰	36000 ⁰⁰
60	Construct Modified Manhole Structure STD 251 #1	EA	1	4200 ⁰⁰	4200 ⁰⁰
61	Construct Manhole Structure STD MH252 #2	EA	1	4300 ⁰⁰	4300 ⁰⁰
62	Construct Manhole Structure STD JS227 #2	EA	3	1300 ⁰⁰	3900 ⁰⁰
63	Construct Frame and Cover for Catch Basin STD CB103	EA	1	300 ⁰⁰	300 ⁰⁰
64	Construct Junction Structure STD JS226 #1	EA	1	1000 ⁰⁰	1000 ⁰⁰
65	Construct Junction Structure STD JS229 #4	EA	3	1300 ⁰⁰	3900 ⁰⁰
66	Construct Transition Structure STD TS303 #3	EA	13	2100 ⁰⁰	27300 ⁰⁰
67	Construct Modified Transition Structure STD TS304 #4	EA	1	30000 ⁰⁰	30000 ⁰⁰
68	Construct Modified Transition Structure STD TS301 #1	EA	2	3100 ⁰⁰	6200 ⁰⁰
69	Construct Modified Transition Structure STD TS301 #1	EA	1	3100 ⁰⁰	3100 ⁰⁰
70	Construct 3'x4' RCB per Caltrans STD D-80	LF	4	1000 ⁰⁰	4000 ⁰⁰
71	Construct 3'x5' RCB per Caltrans STD D-80	LF	4	1000 ⁰⁰	4000 ⁰⁰

RIVERSIDE CONSTRUCTION CO.
 4225 GARNER RD.
 P.O. BOX 1146
 RIVERSIDE, CA 92502

Item No.	Description	Unit	Estimated Quantity	Unit Prices (in figures) Dollars/Cents	Item Total (in figures) Dollars/Cents
72	Construct Headwall Structure per Caltrans STD D-89	EA	1	7000 ⁰⁰	7000 ⁰⁰
73	Install Sewer Steel Casing	LF	24	1200 ⁰⁰	28800 ⁰⁰
74	Construct Concrete Collar	EA	1	850 ⁰⁰	850 ⁰⁰
75	Concrete Encasement per RCFC M807	EA	12	525 ⁰⁰	6300 ⁰⁰
76	Construct Concrete Bulkhead	EA	1	1500 ⁰⁰	1500 ⁰⁰
77	Install 2-Sack Slurry Backfill Over Storm Drain with less than 2' Cover	CY	400	65 ⁰⁰	26000 ⁰⁰
78	Place Storm Drain Bedding and Backfill in Pipe Zone (to 12" over top of pipe). Material to consist of clean plant manufactured sand having a minimum Sand Equivalent of 30 or approved equal.	LS	1	65000 ⁰⁰	65000 ⁰⁰
79	Reconstruct Sewer Lateral per RCFC Std. M808	EA	55	750 ⁰⁰	41250 ⁰⁰
80	Furnish and Install Trench Protection in accordance with Cal/OSHA Standards for Trenches greater than 5' Deep	LS	1	50000 ⁰⁰	50000 ⁰⁰
81	Const. Type A Retaining Curb per Addendum Detail, as required.	LF	1,800	14 ⁰⁰	25200 ⁰⁰

Item No.	Description	Unit	Estimated Quantity	Unit Prices (in figures) Dollars/Cents	Item Total (in figures) Dollars/Cents
82	Const. Type B Retaining Curb per Addendum Detail, as required.	LF	2,600	24 ⁰⁰	62400 ⁰⁰
83	Const. Masonry Retaining Wall per Greenbook Std Plan 618-3 H=3'-4" Max.	SF	4,300	35 ⁰⁰	150500 ⁰⁰
84	Encase Exist. RCSD Sewer Main and Laterals with 2-sack slurry to RCSD specifications within Street lowering area delineated on Street Improvement Plan Sheet No. 9, 10 and 27	LF	1,100	38 ⁰⁰	41800 ⁰⁰
85	Const. Under Sidewalk Drain per Riverside Cnty Std No. 309, as required. (Location not Specified)	EA	20	1550 ⁰⁰	31000 ⁰⁰
86	Const. Private Drain through Curb per Riverside Cnty Std No. 310 as required. (Location not Specified)	EA	20	550 ⁰⁰	11000 ⁰⁰
87	Pothole Exist. Utilities as required for Utility Relocation within Street lowering area delineated on Street Improvement Plan Sheet No. 9, 10 and 27	EA	50	700 ⁰⁰	35000 ⁰⁰
88	Horiz. Sawcut Existing Curb as required for D/W Approach Const.	LF	400	2 ⁰⁰	800 ⁰⁰

Item No.	Description	Unit	Estimated Quantity	Unit Prices (in figures) Dollars/Cents	Item Total (in figures) Dollars/Cents
89	Const. 6" AC Berm per Cnty Std No. 212	LF	500	11 ⁰⁰	5500 ⁰⁰
90	Remove Existing Concrete Sawcut at Removal Limits. Field Verify Removal Limits of All Exist. Residential Driveways with Inspector Prior to Sawcut and Removal	SF	43,000	3.75	161,250 ⁰⁰
91	Remove Exist. Concrete Structure	EA	1	2800 ⁰⁰	2800 ⁰⁰
92	Reconstruct In-Kind Exist. Private Owner Wrought Iron and Block Fence as Required, Recycle W.I. Panels	LF	900	220 ⁰⁰	198,000 ⁰⁰
93	Relocate and/or Adjust to Grade Exist. Private Owner Wrought Iron Gate. Recycle Gate and Install New V-Track and Footing, if Required	LF	2,000	65 ⁰⁰	130,000 ⁰⁰
94	Relocate and/or Adjust to Grade Exist. Private Owner Chain Link Gate, Recycle Material	LF	1,400	36 ⁰⁰	50,400 ⁰⁰
95	Relocate and/or Adjust to Grade Exist. Private Owner Wood Gate, Recycle Material	LF	50	70 ⁰⁰	3500 ⁰⁰
96	Const. Min. 3" AC Paving Over Compacted Native Soil (90% Min.)	SF	3,300	7 ⁰⁰	23,100 ⁰⁰
97	Const. 4" PCC Over Compacted Native Soil (90% Min.)	SF	42,000	3.75	157,500 ⁰⁰

Item No.	Description	Unit	Estimated Quantity	Unit Prices (in figures) Dollars/Cents	Item Total (in figures) Dollars/Cents
98	Const. 4" A.B. or Gravel Surface for Driveway Match-Up Purposes Over Compacted Native Soil (90% Min.)	SF	7,800	3.75	29250 ⁰⁰
99	Install Traffic Signal Loop to RCTD Standards	EA	4	800 ⁰⁰	3200 ⁰⁰
100	Adjust Air-Vac to Grade per RCTD Std W1070	EA	3	3200 ⁰⁰	9600 ⁰⁰
101	Relocate Exist. Waterline per RCSD Standards as required by street lowering as shown on Sht No. 9, 10, and 27				
A	Relocate Exist. 6" Waterline	LF	650	120 ⁰⁰	78000 ⁰⁰
B	Relocate Exist. 8" Waterline	LF	75	105 ⁰⁰	7875 ⁰⁰
C	Relocate Exist. 12" Waterline	LF	250	85 ⁰⁰	21250 ⁰⁰
102	Underground Unforeseen Conditions Allowance. To be used as approved and directed by Agency. Unused monies to be returned to Agency.	T&M	1	\$150,000	\$150,000
104	Hot Tap and connect to Existing 6" A.C.P. Waterline.	EA	4	2300 ⁰⁰	9200 ⁰⁰
105	Hot Tap and connect to Existing 8" D.I.P. Waterline.	EA	2	2800 ⁰⁰	5600 ⁰⁰
106	Hot Tap and connect to Existing 12" PVC Waterline.	EA	2	3200 ⁰⁰	6400 ⁰⁰
107	Encase Existing 6" A.C.P. Waterline	LF	650	25 ⁰⁰	16250 ⁰⁰

Item No.	Description	Unit	Estimated Quantity	Unit Prices (in figures) Dollars/Cents	Item Total (in figures) Dollars/Cents
108	Encase Existing 8" D.I.P Waterline	LF	75	25 ⁰⁰	1875 ⁰⁰
109	Encase Existing 12" PVC Waterline	LF	250	35 ⁰⁰	8750 ⁰⁰
110	Connect Existing Water Meter to New Water Main.	EA	20	1250 ⁰⁰	25000 ⁰⁰

TOTAL SUM BID, ITEMS 1 THROUGH 110: Six million Four Hundred
 (Words)
Eighty Two Thousand Five Hundred (\$ 6,482,507⁰⁰)
 SEVEN (Figures)

The determination of the low bidder will be based on the Base Bid. Bids must be submitted on all items. Failure to bid on all items may result in the bid being rejected as non-responsive.

PAYMENT FOR ITEMS

The following bid items are included in the Bid Proposal for providing a method of payment:

1. Payment for "**Mobilization**" will be made on a lump sum (L.S.) basis, as specified in the bid schedule, which shall include all costs for labor, materials, equipment and permits/authorization required to establish a construction staging area(s) and place a construction trailer and equipment in accordance with the specifications.
2. Payment for "**Storm Water Pollution Prevention Plan & Notice of Intent**" will be made on a lump sum (L.S.) basis, as specified in the bid schedule, which shall include all costs for labor, materials, equipment and permits/authorization required to prepare and implement a storm water pollution prevention plan in accordance with the plans and specifications.
3. Payment for "**Construction Surveying**" will be made on a lump sum (L.S.) basis, as specified in the bid schedule, which shall include all costs for labor, materials, equipment and permits/authorization required to provide construction surveying, staking, establishment of street center lines, etc. in accordance with the plans and specifications.
4. Payment for "**Clearing and Grubbing**" will be made on a lump sum (L.S.) basis, as specified in the bid schedule, which shall include all costs for labor, materials, equipment and permits/authorization required to remove and dispose of resulting material in accordance with the plans and specifications.
5. Payment for "**Traffic Control**" will be made on a lump sum (L.S.) basis, as specified in the bid schedule, which shall include all costs for labor, materials, equipment and permits/authorization required to prepare and gain approval of a traffic control plan and implement traffic control measures in accordance with the plans and specifications.
6. Payment for "**Soils and Material Testing**" will be made on a lump sum (L.S.) basis, as specified in the bid schedule, which shall include all costs for labor, materials, equipment and permits/authorization required to provide soils and material testing and approvals in accordance with the specifications.
7. Payment for "**Signing and Striping**" will be made on a lump sum (L.S.) basis, as specified in the bid schedule, which shall include all costs for labor, materials, equipment and permits/authorization required to provide signing and striping in accordance with the plans and specifications.
8. Payment for "**Developing Water Supply**" will be made on a lump sum (L.S.) basis, as specified in the bid schedule, which shall include all costs for labor, materials, equipment and permits/authorization required to develop a water supply in accordance with the specifications.
9. Payment for "**Roadway Excavation**" will be made on a per cubic yard (C.Y.) basis, as specified in the bid schedule, which shall include all costs for labor, materials, equipment, permits/authorization and performing all work required for excavating, sloping, rounding tops and ends of excavations, loading, hauling, depositing, spreading and compacting the material complete in place and preparing subgrade at the grading plane in accordance with the plans and specifications.
10. Payment for "**Place 3" AC Pavement**" will be made on a per ton (TON) basis, as specified in the bid schedule, which shall include all costs for labor, materials,

11. Payment for **“Place Aggregate Base”** will be made on a per cubic yard (C.Y.) basis, as specified in the bid schedule, which shall include all costs for labor, materials, equipment, permits/authorization and performing all work required to provide, place and compact aggregate base in accordance with the plans and specifications.
12. Payment for **“Fog Seal”** will be made on a per square foot (S.F.) basis, as specified in the bid schedule, which shall include all costs for labor, materials, equipment, permits/authorization and performing all work required to apply fog sealant to AC pavement in accordance with the plans and specifications.
13. Payment for **“Construct 6” Type A-6 Curb and Gutter”** will be made on a per lineal foot (L.F.) basis, as specified in the bid schedule, which shall include all costs for labor, materials, equipment, permits/authorization and performing all work required to prepare subgrade, place and remove forms and finish concrete in accordance with the plans and specifications.
14. Payment for **“ Construct 4” Sidewalk”** will be made on a per square foot (S.F.) basis, as specified in the bid schedule, which shall include all costs for labor, materials, equipment, permits/authorization and performing all work required to prepare subgrade, place and remove forms and finish concrete in accordance with the plans and specifications.
15. Payment for **“Construct Driveway Approach”** will be made on a per square foot (S.A.) basis, as specified in the bid schedule, which shall include all costs for labor, materials, equipment, permits/authorization and performing all work required to prepare subgrade, place and remove forms and finish concrete in accordance with the plans and specifications.
16. Payment for **“Construct Access Ramp”** will be made on a per each (E.A.) basis, as specified in the bid schedule, which shall include all costs for labor, materials, equipment, permits/authorization and performing all work required to prepare subgrade, place and remove forms and finish concrete in accordance with the plans and specifications.
17. Payment for **“Adjust Manhole Cover to Grade”** will be made on a per each (E.A.) basis, as specified in the bid schedule, which shall include all costs for labor, materials, equipment, permits/authorization and performing all work required to adjust existing manholes to grade in accordance with the plans and specifications.
18. Payment for **“Adjust Valve Cover to Grade”** will be made on a per each (E.A.) basis, as specified in the bid schedule, which shall include all costs for labor, materials, equipment, permits/authorization and performing all work required to adjust existing valve covers and cans to grade in accordance with the plans and specifications.
19. Payment for **“Remove Existing Catch Basin”** will be made on a per each (E.A.) basis, as specified in the bid schedule, which shall include all costs for labor, materials, equipment, permits/authorization and performing all work required to remove the existing catch basin and legally dispose of the material in accordance with the plans and specifications.
20. Payment for **“Cold Plane 0.1' Existing Pavement”** will be made on a per square foot (S.F.) basis, as specified in the bid schedule, which shall include all costs for labor, materials, equipment, permits/authorization and performing all work required to

21. Payment for **“Construct 0.1' AC Overlay”** will be made on a per square yard (S.Y.) basis, as specified in the bid schedule, which shall include all costs for labor, materials, equipment, permits/authorization and performing all work required to construct AC overlay on existing pavement in accordance with the plans and specifications.
22. Payment for **“Construct Cross Gutter”** will be made on a per square foot (S.F.) basis, as specified in the bid schedule, which shall include all costs for labor, materials, equipment, permits/authorization and performing all work required to prepare subgrade, place and remove forms and finish concrete in accordance with the plans and specifications.
23. Payment for **“Construct 6” Slump Stone Wall”** will be made on a per square foot (S.F.) basis, as specified in the bid schedule, which shall include all costs for labor, materials, equipment, permits/authorization and performing all work required to prepare subgrade, place footing and construct 6” CMU slump stone screen wall in accordance with the plans and specifications.
24. Payment for **“Remove Existing AC and Base”** will be made on a per square foot (S.F.) basis, as specified in the bid schedule, which shall include all costs for labor, materials, equipment, permits/authorization and performing all work required to saw cut and remove existing asphalt concrete pavement and aggregate base and legally dispose of the material in accordance with the plans and specifications.
25. Payment for **“Remove Existing Tree”** will be made on a per each (E.A.) basis, as specified in the bid schedule, which shall include all costs for labor, materials, equipment, permits/authorization and performing all work required to remove the existing tree, bush or stump, fill and compact the hole and legally dispose of the material in accordance with the plans and specifications.
26. Payment for **“Remove Existing Curb”** will be made on a per lineal foot (L.F.) basis, as specified in the bid schedule, which shall include all costs for labor, materials, equipment, permits/authorization and performing all work required to saw cut and remove existing concrete curb, gutter and or spandrel in accordance with the plans and specifications.
27. Payment for **“Remove Existing Guard Post”** will be made on a per each (E.A.) basis, as specified in the bid schedule, which shall include all costs for labor, materials, equipment, permits/authorization and performing all work required to remove the existing guard post and legally dispose of the material in accordance with the plans and specifications.
28. Payment for **“Relocate Existing Sign and Post”** will be made on a per each (E.A.) basis, as specified in the bid schedule, which shall include all costs for labor, materials, equipment, permits/authorization and performing all work required to remove existing sign and post and associated footing, install sign and post in new location and legally dispose of removed materials in accordance with the plans and specifications.
29. Payment for **“Relocate Existing Mailbox”** will be made on a per each (E.A.) basis, as specified in the bid schedule, which shall include all costs for labor, materials, equipment, permits/authorization and performing all work required to remove existing mailbox and footing, install mailbox in new location and legally dispose of removed

30. Payment for **“Replace 12 Existing Mailboxes with Gang Box”** will be made on a per each (E.A.) basis, as specified in the bid schedule, which shall include all costs for labor, materials, equipment, permits/authorization and performing all work required to remove the existing mailboxes and footings, install new gang box and legally dispose of removed materials in accordance with the plans and specifications.
31. Payment for **“Relocate Existing Drain”** will be made on a per each (E.A.) basis, as specified in the bid schedule, which shall include all costs for labor, materials, equipment, permits/authorization and performing all work required to remove the existing drain, install drain in new location and legally dispose of the removed materials in accordance with the plans and specifications.
32. Payment for **“Relocate Private Lamp”** will be made on a per each (E.A.) basis, as specified in the bid schedule, which shall include all costs for labor, materials, equipment, permits/authorization and performing all work required to remove existing private lamp and footing, install lamp in new location and legally dispose of removed materials in accordance with the plans and specifications.
33. Payment for **“Relocate Private Wall”** will be made on a per lineal foot (L.F.) basis, as specified in the bid schedule, which shall include all costs for labor, materials, equipment, permits/authorization and performing all work required to remove the existing wall, footing, construct wall in new location and legally dispose of removed materials in accordance with the plans and specifications.
34. Payment for **“Relocate Private Chain Link Fence”** will be made on a per lineal foot (L.F.) basis, as specified in the bid schedule, which shall include all costs for labor, materials, equipment, permits/authorization and performing all work required to remove existing chain link fence, footing, install chain link fence in new location and legally dispose of removed materials in accordance with the plans and specifications.
35. Payment for **“Relocate Private Wood Fence”** will be made on a per lineal foot (L.F.) basis, as specified in the bid schedule, which shall include all costs for labor, materials, equipment, permits/authorization and performing all work required to remove existing wood fence, footing, install wood fence in new location and legally dispose of removed materials in accordance with the plans and specifications.
36. Payment for **“Relocate Private Wrought Iron Fence”** will be made on a per lineal foot (L.F.) basis, as specified in the bid schedule, which shall include all costs for labor, materials, equipment, permits/authorization and performing all work required to remove the existing wrought iron fence, footing, install wrought iron fence in new location and legally dispose of removed materials in accordance with the plans and specifications.
37. Payment for **“Relocate Existing Backflow Device”** will be made on a per each (E.A.) basis, as specified in the bid schedule, which shall include all costs for labor, materials, equipment, permits/authorization and performing all work required to remove existing backflow device, install backflow device in new location and legally dispose of removed materials in accordance with the plans and specifications.
38. Payment for **“Relocate Existing Vault”** will be made on a per each (E.A.) basis, as specified in the bid schedule, which shall include all costs for labor, materials, equipment, permits/authorization and performing all work required to remove existing vault and appurtenances, install vault in new location and legally dispose of removed materials in accordance with the plans specifications.

39. Payment for **“Construct Desilting Drain Inlet”** will be made on a per each (E.A.) basis, as specified in the bid schedule, which shall include all costs for labor, materials, equipment, permits/authorization and performing all work required to prepare subgrade, place forms and reinforcement, remove forms and finish concrete in accordance with the plans and specifications.
40. Payment for **“Install Type F Markers”** will be made on a per each (E.A.) basis, as specified in the bid schedule, which shall include all costs for labor, materials, equipment, permits/authorization and performing all work required to install Type F road markers in accordance with the plans and specifications.
41. Payment for **“Relocate Existing Fire Hydrant”** will be made on a per each (E.A.) basis, as specified in the bid schedule, which shall include all costs for labor, materials, equipment, permits/authorization and performing all work required to remove existing fire hydrant and appurtenances, install fire hydrant in new location and legally dispose of removed materials in accordance with the plans and specifications.
42. Payment for **“Relocate Existing Water Meter”** will be made on a per each (E.A.) basis, as specified in the bid schedule, which shall include all costs for labor, materials, equipment, permits/authorization and performing all work required to remove existing water meter and appurtenances, install water meter in new location and legally dispose of removed materials in accordance with the plans and specifications.
43. Payment for **“Relocate Existing Fire Dept. Service”** will be made on a per each (E.A.) basis, as specified in the bid schedule, which shall include all costs for labor, materials, equipment, permits/authorization and performing all work required to remove existing Fire Department service and appurtenances, install Fire Department service in new location and legally dispose of removed materials in accordance with the plans and specifications.
44. Payment for **“Relocate Existing Irrigation Control Valve”** will be made on a per each (E.A.) basis, as specified in the bid schedule, which shall include all costs for labor, materials, equipment, permits/authorization and performing all work required to remove existing irrigation control valve and appurtenances, install irrigation control valve in new location and legally dispose of removed materials in accordance with the plans specifications.
45. Payment for **“Install New Street Light”** will be made on a per each (E.A.) basis, as specified in the bid schedule, which shall include all costs for labor, materials, equipment, permits/authorization and performing all work required to install street light in accordance with the plans and specifications.
46. Payment for **“Install 18” RCP (2000-D)”** will be made on a per lineal foot (L.F.) basis, as specified in the bid schedule, which shall include all costs for labor, materials, equipment, permits/authorization and performing all work required to trench, place bedding, install pipe, backfill and compact in accordance with the plans and specifications.
47. Payment for **“Install 24” RCP (2000-D)”** will be made on a per lineal foot (L.F.) basis, as specified in the bid schedule, which shall include all costs for labor, materials, equipment, permits/authorization and performing all work required to trench, place bedding, install pipe, backfill and compact in accordance with the plans and specifications.

48. Payment for **"Install 36" RCP (1500-D)"** will be made on a per lineal foot (L.F.) basis, as specified in the bid schedule, which shall include all costs for labor, materials, equipment, permits/authorization and performing all work required to trench, place bedding, install pipe, backfill and compact in accordance with the plans and specifications.
49. Payment for **"Install 42" RCP (1200-D)"** will be made on a per lineal foot (L.F.) basis, as specified in the bid schedule, which shall include all costs for labor, materials, equipment, permits/authorization and performing all work required to trench, place bedding, install pipe, backfill and compact in accordance with the plans and specifications.
50. Payment for **"Install 48" RCP (1500-D)"** will be made on a per lineal foot (L.F.) basis, as specified in the bid schedule, which shall include all costs for labor, materials, equipment, permits/authorization and performing all work required to trench, place bedding, install pipe, backfill and compact in accordance with the plans and specifications.
51. Payment for **"Install 60" RCP (1600-D)"** will be made on a per lineal foot (L.F.) basis, as specified in the bid schedule, which shall include all costs for labor, materials, equipment, permits/authorization and performing all work required to trench, place bedding, install pipe, backfill and compact in accordance with the plans and specifications.
52. Payment for **"Install Catch Basin STD 300 W=7"** will be made on a per each (E.A.) basis, as specified in the bid schedule, which shall include all costs for labor, materials, equipment, permits/authorization and performing all work required to prepare subgrade, place forms and reinforcement, remove forms and finish concrete in accordance with the plans specifications.
53. Payment for **"Install Catch Basin STD 300 W=14"** will be made on a per each (E.A.) basis, as specified in the bid schedule, which shall include all costs for labor, materials, equipment, permits/authorization and performing all work required to prepare subgrade, place forms and reinforcement, remove forms and finish concrete in accordance with the plans specifications.
54. Payment for **"Install Catch Basin STD 300 W=22"** will be made on a per each (E.A.) basis, as specified in the bid schedule, which shall include all costs for labor, materials, equipment, permits/authorization and performing all work required to prepare subgrade, place forms and reinforcement, remove forms and finish concrete in accordance with the plans specifications.
55. Payment for **"Install Catch Basin STD 302 W=7"** will be made on a per each (E.A.) basis, as specified in the bid schedule, which shall include all costs for labor, materials, equipment, permits/authorization and performing all work required to prepare subgrade, place forms and reinforcement, remove forms and finish concrete in accordance with the plans specifications.
56. Payment for **"Install Drop Inlet STD CB110"** will be made on a per each (E.A.) basis, as specified in the bid schedule, which shall include all costs for labor, materials, equipment, permits/authorization and performing all work required to prepare subgrade, place forms and reinforcement, remove forms and finish concrete in accordance with the plans specifications.
57. Payment for **"Construct Manhole Structure STD MH253 #3"** will be made on a per each (E.A.) basis, as specified in the bid schedule, which shall include all costs for

58. Payment for **“Construct Manhole Structure STD MH254 #4”** will be made on a per each (E.A.) basis, as specified in the bid schedule, which shall include all costs for labor, materials, equipment, permits/authorization and performing all work required to prepare subgrade, place forms and reinforcement, install cover, remove forms and finish concrete in accordance with the plans specifications.
59. Payment for **“Construct Manhole Structure STD MH251 #1”** will be made on a per each (E.A.) basis, as specified in the bid schedule, which shall include all costs for labor, materials, equipment, permits/authorization and performing all work required to prepare subgrade, place forms and reinforcement, install cover, remove forms and finish concrete in accordance with the plans specifications.
60. Payment for **“Construct Modified Manhole Structure STD MH251 #1”** will be made on a per each (E.A.) basis, as specified in the bid schedule, which shall include all costs for labor, materials, equipment, permits/authorization and performing all work required to prepare subgrade, place forms and reinforcement, install cover, remove forms and finish concrete in accordance with the plans specifications.
61. Payment for **“Construct Manhole Structure STD MH252 #2”** will be made on a per each (E.A.) basis, as specified in the bid schedule, which shall include all costs for labor, materials, equipment, permits/authorization and performing all work required to prepare subgrade, place forms and reinforcement, install cover, remove forms and finish concrete in accordance with the plans specifications.
62. Payment for **“Construct Manhole Structure STD JS227 #2”** will be made on a per each (E.A.) basis, as specified in the bid schedule, which shall include all costs for labor, materials, equipment, permits/authorization and performing all work required to prepare subgrade, place forms and reinforcement, install cover, remove forms and finish concrete in accordance with the plans specifications.
63. Payment for **“Construct Frame and Cover for Catch Basin STD CB103”** will be made on a per each (E.A.) basis, as specified in the bid schedule, which shall include all costs for labor, materials, equipment, permits/authorization and performing all work required to prepare subgrade, place forms and reinforcement, install cover, remove forms and finish concrete in accordance with the plans specifications.
64. Payment for **“Construct Junction Structure STD JS226 #1”** will be made on a per each (E.A.) basis, as specified in the bid schedule, which shall include all costs for labor, materials, equipment, permits/authorization and performing all work required to prepare subgrade, place forms and reinforcement, remove forms and finish concrete in accordance with the plans specifications.
65. Payment for **“Construct Junction Structure STD JS229 #4 ”** will be made on a per each (E.A.) basis, as specified in the bid schedule, which shall include all costs for labor, materials, equipment, permits/authorization and performing all work required to prepare subgrade, place forms and reinforcement, remove forms and finish concrete in accordance with the plans specifications.
66. Payment for **“Construct Transition Structure STD TS303 #3”** will be made on a per each (E.A.) basis, as specified in the bid schedule, which shall include all costs for labor, materials, equipment, permits/authorization and performing all work required to prepare subgrade, place forms and reinforcement, remove forms and

67. Payment for **“Construct Modified Transition Structure STD TS304 #4”** will be made on a per each (E.A.) basis, as specified in the bid schedule, which shall include all costs for labor, materials, equipment, permits/authorization and performing all work required to prepare subgrade, place forms and reinforcement, remove forms and finish concrete in accordance with the plans specifications.
68. Payment for **“Construct Modified Transition Structure STD TS301 #1”** will be made on a per each (E.A.) basis, as specified in the bid schedule, which shall include all costs for labor, materials, equipment, permits/authorization and performing all work required to prepare subgrade, place forms and reinforcement, remove forms and finish concrete in accordance with the plans specifications.
69. Payment for **“Construct Modified Transition Structure STD TS301 #1”** will be made on a per each (E.A.) basis, as specified in the bid schedule, which shall include all costs for labor, materials, equipment, permits/authorization and performing all work required to prepare subgrade, place forms and reinforcement, remove forms and finish concrete in accordance with the plans specifications.
70. Payment for **“Construct 3'x4' RCB per Caltrans STD D-80”** will be made on a per lineal foot (L.F.) basis, as specified in the bid schedule, which shall include all costs for labor, materials, equipment, permits/authorization and performing all work required to trench, place bedding, install box, backfill and compact in accordance with the plans and specifications.
71. Payment for **“Construct 3'x5' RCB per Caltrans STD D-80”** will be made on a per lineal foot (L.F.) basis, as specified in the bid schedule, which shall include all costs for labor, materials, equipment, permits/authorization and performing all work required to trench, place bedding, install box, backfill and compact in accordance with the plans and specifications.
72. Payment for **“Construct Headwall Structure per Caltrans STD D-89”** will be made on a per each (E.A.) basis, as specified in the bid schedule, which shall include all costs for labor, materials, equipment, permits/authorization and performing all work required to prepare subgrade, place forms and reinforcement, remove forms and finish concrete in accordance with the plans specifications.
73. Payment for **“Install Sewer Steel Casing”** will be made on a per lineal foot (L.F.) basis, as specified in the bid schedule, which shall include all costs for labor, materials, equipment, permits/authorization and performing all work required to install steel casing around the existing sewer line in accordance with the plans and specifications.
74. Payment for **“Construct Concrete Collar”** will be made on a per each (E.A.) basis, as specified in the bid schedule, which shall include all costs for labor, materials, equipment, permits/authorization and performing all work required to place and remove forms and finish concrete in accordance with the plans and specifications.
75. Payment for **“Construct Concrete Encasement”** will be made on a per lineal foot (L.F.) basis, as specified in the bid schedule, which shall include all costs for labor, materials, equipment, permits/authorization and performing all work required to place and remove forms and finish concrete in accordance with the plans and specifications.
76. Payment for **“Construct Concrete Bulkhead”** will be made on a per each (E.A.) basis, as specified in the bid schedule, which shall include all costs for labor,

RIVERSIDE CONSTRUCTION CO.
4225 GARNER RD.
P.O. BOX 1148
RIVERSIDE, CA 92502

AWARD OF CONTRACT

The undersigned fully understands that a Contract is formed upon the acceptance of this proposal by the Owner, and the undersigned further agrees that upon request he will promptly execute and deliver to Owner a written memorial of the Contract together with the required labor and material and performance bonds.

BID GUARANTEE

The enclosed certified or cashier's check or bidder's bond on approved form, made payable to the Owner, in the amount of ten percent (10%) of the total bid submitted herewith, is hereby given as guarantee that the bidder will execute and deliver the above mentioned written memorial and required bonds if awarded the contract, and in the event that the undersigned fails or refuses to execute and deliver said documents, such check or bond is to be charged with the costs of the damages experienced by the Owner as a result of such failure or refusal, including, but not limited to publication costs, the difference in money between the amount of the bid of the said principal and the amount for which obligee may legally contract with another party to perform the said work if such amount be in excess of the former, building lease or rental costs, transportation costs and additional salary costs that result from the delay due to the principal's default on the awarded contract. In no event, however, shall the Surety's liability exceed the penal sum hereof.

Name of Bidder _____

Type of Organization Corporation _____

Signed By  _____
George J. Olivo

Title of Signer Secretary _____

Address of Bidder 4225 Garner Rd., Riverside, CA 92501 _____

Telephone Number (951) 682-8308

Contractor's License 266222 _____ Classification A,B,C20,C38,C

If bidder is a corporation, and signer is not President or Secretary, attach certified copy of Bylaws or resolution authorizing execution. If bidder is a corporation, affix corporate seal. If signer is an agent, attach Power of Attorney. If bidder is not an individual, list names of other persons authorized to bind the organization.

BID BOND

KNOW ALL MEN BY THESE PRESENTS, that we, the undersigned
Riverside Construction Company, Inc.

_____, as Principal : and Fidelity and Deposit Company of Maryland
_____, as Surety, are hereby held and firmly bound unto the Redevelopment Agency for
the County of Riverside, hereinafter called the "Owner", in the sum of
ten * dollars (\$ 10%) for the payment of which sum, well and truly to be
made, were hereby jointly and severally bind ourselves, our heirs, executors,
administrators, successors and assigns. *percent of the total bid amount

WHEREAS, the said Principal is herewith submitting its proposal for the construction of
Rubidoux, Area II Street And Storm Drain Improvement Project

THE CONDITION OF THE ABOVE OBLIGATION IS SUCH, that if the aforesaid Principal
shall be awarded the contract upon said proposal and shall, within the required number of
days after the notice of such award, execute a written memorial of the awarded contract
and submit the required labor and material and faithful performance bond, then this
obligation shall be null and void; and in the event that the principal fails and/or refuses to
execute and deliver said documents this bond will be charged with the costs of the
damages experienced by the Owner as a result of such refusal, including but not limited to,
publication cost, the difference in money between the amount of the bid of the said principal
and the amount for which the obligee may legally contract with another party to perform the
said work if such amount be in excess of the former; building lease or rental costs,
transportation costs, and additional salary costs that result from the delay due to the
principal's default on the awarded contract. In no event however, shall the Surety's liability
exceed the penal sum hereof.

The Surety, for value received, hereby stipulates and agrees that the obligations of said
Surety and its bond shall be in no way impaired or affected by any extension of the time
within which the Owner may accept such bid; and said Surety does hereby waive notice of
any such extension.

IN WITNESS WHEREOF, the above-bounded parties have executed this instrument under
their several seals this 18th day of April, 2011, the name and corporate seal of
each corporate party being hereto affixed and these presents duly signed by its
undersigned representative, pursuant to authority of its governing body.

RIVERSIDE CONSTRUCTION CO.
4225 GARNER RD.
P.O. BOX 1143
RIVERSIDE, CA 92502

In the presence of:

_____	_____ (Seal)
	Individual Principal
_____	_____
Address	Business Address
_____	_____ (Seal)
	Individual Principal
_____	_____
Address	Business Address

Attest: _____
BRUN P...

RIVERSIDE CONSTRUCTION COMPANY, INC.
DR. S. O...

 Corporate Principal
Garner S. O...

 4225 Garner Rd., Riverside, CA 92501
 Business Address

By _____
(Affix Corporate Seal)

Attest: _____
 Fidelity and Deposit
 Company of Maryland

 Corporate Principal
 Surety Company
 801 N. Brand Blvd., PH, Glendale, CA 91203

 Business Address

By *Cristin Nolette*

 (Affix Corporate Seal)
 Cristin Nolette
 Attorney-in-Fact

The rate of premium on this bond is N/A per thousand. Total amount of premium charged, \$ N/A.

(The above must be filled in by corporate surety.)

EXTRACT FROM BY-LAWS OF FIDELITY AND DEPOSIT COMPANY OF MARYLAND

"Article VI, Section 2. The Chairman of the Board, or the President, or any Executive Vice-President, or any of the Senior Vice-Presidents or Vice-Presidents specially authorized so to do by the Board of Directors or by the Executive Committee, shall have power, by and with the concurrence of the Secretary or any one of the Assistant Secretaries, to appoint Resident Vice-Presidents, Assistant Vice-Presidents and Attorneys-in-Fact as the business of the Company may require, or to authorize any person or persons to execute on behalf of the Company any bonds, undertakings, recognizances, stipulations, policies, contracts, agreements, deeds, and releases and assignments of judgements, decrees, mortgages and instruments in the nature of mortgages,....and to affix the seal of the Company thereto."

CERTIFICATE

I, the undersigned, Assistant Secretary of the FIDELITY AND DEPOSIT COMPANY OF MARYLAND, do hereby certify that the foregoing Power of Attorney is still in full force and effect on the date of this certificate; and I do further certify that the Vice-President who executed the said Power of Attorney was one of the additional Vice-Presidents specially authorized by the Board of Directors to appoint any Attorney-in-Fact as provided in Article VI, Section 2, of the By-Laws of the FIDELITY AND DEPOSIT COMPANY OF MARYLAND.

This Power of Attorney and Certificate may be signed by facsimile under and by authority of the following resolution of the Board of Directors of the FIDELITY AND DEPOSIT COMPANY OF MARYLAND at a meeting duly called and held on the 10th day of May, 1990.

RESOLVED: "That the facsimile or mechanically reproduced seal of the company and facsimile or mechanically reproduced signature of any Vice-President, Secretary, or Assistant Secretary of the Company, whether made heretofore or hereafter, wherever appearing upon a certified copy of any power of attorney issued by the Company, shall be valid and binding upon the Company with the same force and effect as though manually affixed."

IN TESTIMONY WHEREOF, I have hereunto subscribed my name and affixed the corporate seal of the said Company,

this 18th day of April, 2011.



Assistant Secretary

Power of Attorney
FIDELITY AND DEPOSIT COMPANY OF MARYLAND

KNOW ALL MEN BY THESE PRESENTS: That the FIDELITY AND DEPOSIT COMPANY OF MARYLAND, a corporation of the State of Maryland, by WILLIAM J. MILLS, Vice President, and GREGORY E. MURRAY, Assistant Secretary, in pursuance of authority granted by Article VI, Section 2, of the By-Laws of said Company, which are set forth on the reverse side hereof and are hereby certified to be in full force and effect on the date hereof does hereby nominate, constitute and appoint **Cristin NOLETTE, of Irvine, California**, its true and lawful agent and Attorney-in-Fact, to make, execute, seal and deliver, for, and on its behalf as surety, and as its act and deed, **any and all bonds and undertakings**, and the execution of such bonds or undertakings in pursuance of these presents, shall be as binding upon said Company, as fully and amply, to all intents and purposes, as if they had been duly executed and acknowledged by the regularly elected officers of the Company at its office in Baltimore, Md., in their own proper persons. This power of attorney revokes that issued on behalf of Cristin NOLETTE dated October 15, 2008.

The said Assistant Secretary does hereby certify that the extract set forth on the reverse side hereof is a true copy of Article VI, Section 2, of the By-Laws of said Company, and is now in force.

IN WITNESS WHEREOF, the said Vice-President and Assistant Secretary have hereunto subscribed their names and affixed the Corporate Seal of the said FIDELITY AND DEPOSIT COMPANY OF MARYLAND, this 24th day of June, A.D. 2009.

ATTEST:

FIDELITY AND DEPOSIT COMPANY OF MARYLAND



Gregory E. Murray By: *William J. Mills*
Gregory E. Murray Assistant Secretary William J. Mills Vice President

State of Maryland }
City of Baltimore } ss:

On this 24th day of June, A.D. 2009, before the subscriber, a Notary Public of the State of Maryland, duly commissioned and qualified, came WILLIAM J. MILLS, Vice President, and GREGORY E. MURRAY, Assistant Secretary of the FIDELITY AND DEPOSIT COMPANY OF MARYLAND, to me personally known to be the individuals and officers described in and who executed the preceding instrument, and they each acknowledged the execution of the same, and being by me duly sworn, severally and each for himself deposed and saith, that they are the said officers of the Company aforesaid, and that the seal affixed to the preceding instrument is the Corporate Seal of said Company, and that the said Corporate Seal and their signatures as such officers were duly affixed and subscribed to the said instrument by the authority and direction of the said Corporation.

IN TESTIMONY WHEREOF, I have hereunto set my hand and affixed my Official Seal the day and year first above written.



Maria D. Adamski
Maria D. Adamski Notary Public
My Commission Expires: July 8, 2011

CALIFORNIA ALL-PURPOSE ACKNOWLEDGMENT

RIVERSIDE COUNTY, CALIF.
4225 GARNER RD.
P.O. BOX 1146
RIVERSIDE, CA 92502

State of California
County of Orange

On April 18, 2011 before me, Suzan M. Martinez, Notary Public
NAME

personally appeared Cristin Nolette
NAME OF SIGNER

who proved to me on the basis of satisfactory evidence to be the person whose name is subscribed to the within instrument and acknowledged to me that she executed the same in her authorized capacity, and that by her signature on the instrument the person, or the entity upon behalf of which the person acted, executed the instrument.



I, certify under PENALTY OF PERJURY under the laws of the State of California that the foregoing paragraph is true and correct.

WITNESS my hand and official seal.

[Signature of Suzan M. Martinez]
(SIGNATURE OF NOTARY)

OPTIONAL

Though the data below is not required by law, it may prove valuable to persons relying on the document and could prevent fraudulent reattachment of this form.

CAPACITY CLAIMED BY SIGNER

DESCRIPTION OF ATTACHED DOCUMENT

- INDIVIDUAL
CORPORATE OFFICER
TITLE(S)
PARTNER(S) LIMITED
GENERAL

TITLE OR TYPE OF DOCUMENT
NUMBER OF PAGES

- ATTORNEY-IN-FACT
TRUSTEE(S)
GUARDIAN/CONSERVATOR
OTHER

DATE OF DOCUMENT

SIGNER IS REPRESENTING:
NAME OF PERSON(S) OR ENTITY(IES)

SIGNER OTHER THAN NAMED ABOVE

CALIFORNIA ALL-PURPOSE CERTIFICATE OF ACKNOWLEDGMENT

State of California

County of RIVERSIDE

RIVERSIDE CONSTRUCTION CO.
4225 GARNER RD.
P.O. BOX 1146
RIVERSIDE, CA 92502

On JUNE 3, 2011 before me, BRIAN R. PIM, NOTARY PUBLIC
(Here insert name and title of the officer)

personally appeared GEORGE J. OLIVO

who proved to me on the basis of satisfactory evidence to be the person(s) whose name(s) is/are subscribed to the within instrument and acknowledged to me that he/she/they executed the same in his/her/their authorized capacity(ies), and that by his/her/their signature(s) on the instrument the person(s), or the entity upon behalf of which the person(s) acted, executed the instrument.

I certify under PENALTY OF PERJURY under the laws of the State of California that the foregoing paragraph is true and correct.

WITNESS my hand and official seal.

Brian R. Pim

Signature of Notary Public

(Notary Seal)



ADDITIONAL OPTIONAL INFORMATION

INSTRUCTIONS FOR COMPLETING THIS FORM

Any acknowledgment completed in California must contain verbiage exactly as appears above in the notary section or a separate acknowledgment form must be properly completed and attached to that document. The only exception is if a document is to be recorded outside of California. In such instances, any alternative acknowledgment verbiage as may be printed on such a document so long as the verbiage does not require the notary to do something that is illegal for a notary in California (i.e. certifying the authorized capacity of the signer). Please check the document carefully for proper notarial wording and attach this form if required.

- State and County information must be the State and County where the document signer(s) personally appeared before the notary public for acknowledgment.
- Date of notarization must be the date that the signer(s) personally appeared which must also be the same date the acknowledgment is completed.
- The notary public must print his or her name as it appears within his or her commission followed by a comma and then your title (notary public).
- Print the name(s) of document signer(s) who personally appear at the time of notarization.
- Indicate the correct singular or plural forms by crossing off incorrect forms (i.e. he/she/they, is /are) or circling the correct forms. Failure to correctly indicate this information may lead to rejection of document recording.
- The notary seal impression must be clear and photographically reproducible. Impression must not cover text or lines. If seal impression smudges, re-seal if a sufficient area permits, otherwise complete a different acknowledgment form.
- Signature of the notary public must match the signature on file with the office of the county clerk.
 - ❖ Additional information is not required but could help to ensure this acknowledgment is not misused or attached to a different document.
 - ❖ Indicate title or type of attached document, number of pages and date.
 - ❖ Indicate the capacity claimed by the signer. If the claimed capacity is a corporate officer, indicate the title (i.e. CEO, CFO, Secretary).
- Securely attach this document to the signed document

DESCRIPTION OF THE ATTACHED DOCUMENT

(Title or description of attached document)

(Title or description of attached document continued)

Number of Pages _____ Document Date _____

(Additional information)

CAPACITY CLAIMED BY THE SIGNER

Individual (s)

Corporate Officer

(Title)

Partner(s)

Attorney-in-Fact

Trustee(s)

Other _____

NON-COLLUSION AFFIDAVIT

TO BE EXECUTED BY BIDDER AND SUBMITTED WITH BID

STATE OF CALIFORNIA)
)SS
COUNTY OF RIVERSIDE)

George J. Olivo, being first duly sworn, deposes and says:

That he or she is Secretary of
Riverside Construction Company, Inc.

the party making the foregoing bid; that the bid is not made in the interest of, or on behalf of, any undisclosed person, partnership, company, association, organization, or corporation; that the bid is genuine and not collusive or sham; that the bidder has not directly or indirectly induced or solicited any other bidder to put in a false or sham bid, and has not directly or indirectly colluded, conspired, connived, or agreed with any bidder or anyone else to put in a sham bid, or that anyone shall refrain from bidding; that the bidder has not in any manner, directly or indirectly, sought by agreement, communication, or conference with anyone to fix the bid price of the bidder or any other bidder, or to fix any overhead, profit, or cost element of the bid price, or of that of any other bidder, or to secure any advantage against the public body awarding the contract of anyone interested in the proposed contract; that all statements contained in the bid are true; and, further, that the bidder has not, directly or indirectly, submitted his or her bid price or any breakdown thereof, or the contents thereof, or divulged information or data relative thereto, or paid, and will not pay, any fee to any depository, or to any member or agent thereof to effectuate a collusive or sham bid.



Signature

Subscribed and sworn to before me this 3 day of June, 2011



Signature of Officer Administering Oath

CALIFORNIA ALL-PURPOSE CERTIFICATE OF ACKNOWLEDGMENT

State of California

County of RIVERSIDE

RIVERSIDE CONSTRUCTION CO.
4225 GARNER RD.
P.O. BOX 1146
RIVERSIDE, CA 92502

On JUNE 6, 2011 before me, BRIAN R. PIM, Notary Public
(Here insert name and title of the officer)

personally appeared GEORGE J. OLIVO

who proved to me on the basis of satisfactory evidence to be the person(s) whose name(s) is/are subscribed to the within instrument and acknowledged to me that he/she/they executed the same in his/her/their authorized capacity(ies), and that by his/her/their signature(s) on the instrument the person(s), or the entity upon behalf of which the person(s) acted, executed the instrument.

I certify under PENALTY OF PERJURY under the laws of the State of California that the foregoing paragraph is true and correct.

WITNESS my hand and official seal.

Brian R. Pim
Signature of Notary Public

(Notary Seal)

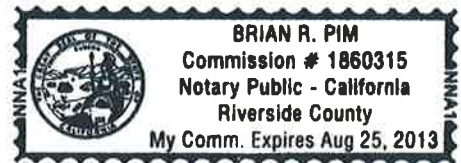

ADDITIONAL OPTIONAL INFORMATION

INSTRUCTIONS FOR COMPLETING THIS FORM

Any acknowledgment completed in California must contain verbiage exactly as appears above in the notary section or a separate acknowledgment form must be properly completed and attached to that document. The only exception is if a document is to be recorded outside of California. In such instances, any alternative acknowledgment verbiage as may be printed on such a document so long as the verbiage does not require the notary to do something that is illegal for a notary in California (i.e. certifying the authorized capacity of the signer). Please check the document carefully for proper notarial wording and attach this form if required.

- State and County information must be the State and County where the document signer(s) personally appeared before the notary public for acknowledgment.
- Date of notarization must be the date that the signer(s) personally appeared which must also be the same date the acknowledgment is completed.
- The notary public must print his or her name as it appears within his or her commission followed by a comma and then your title (notary public).
- Print the name(s) of document signer(s) who personally appear at the time of notarization.
- Indicate the correct singular or plural forms by crossing off incorrect forms (i.e. he/she/they, is/are) or circling the correct forms. Failure to correctly indicate this information may lead to rejection of document recording.
- The notary seal impression must be clear and photographically reproducible. Impression must not cover text or lines. If seal impression smudges, re-seal if a sufficient area permits, otherwise complete a different acknowledgment form.
- Signature of the notary public must match the signature on file with the office of the county clerk.
 - ❖ Additional information is not required but could help to ensure this acknowledgment is not misused or attached to a different document.
 - ❖ Indicate title or type of attached document, number of pages and date.
 - ❖ Indicate the capacity claimed by the signer. If the claimed capacity is a corporate officer, indicate the title (i.e. CEO, CFO, Secretary).
- Securely attach this document to the signed document

DESCRIPTION OF THE ATTACHED DOCUMENT

(Title or description of attached document)

(Title or description of attached document continued)

Number of Pages _____ Document Date _____

(Additional information)

CAPACITY CLAIMED BY THE SIGNER

- Individual (s)
 Corporate Officer

(Title)

- Partner(s)
 Attorney-in-Fact
 Trustee(s)
 Other _____

AGREEMENT FORM

THIS AGREEMENT entered into this ____ day of _____, 20__, by and between _____, hereinafter called the "Contractor" and the Redevelopment Agency for the County of Riverside, hereinafter called the "Owner".

WITNESSETH

That the parties hereto have mutually covenanted and agreed as follows:

CONTRACT: The complete Contract includes all of the Contract Documents, to wit: The Notice Inviting Bids, the Instructions to Bidders, the Contractor's Proposal, the Payment and Performance Bonds, the Plans and Specifications plus any Addenda thereto, the General Conditions, Special and Technical Provisions, and this Agreement. All contract documents are intended to cooperate and be complementary so that any work called for in one and not mentioned in the other, or vice versa, is to be executed the same as if mentioned in all contract documents.

STATEMENT OF WORK: The Contractor hereby agrees to furnish all tools, equipment, services, apparatus, facilities, transportation, labor, and materials for the construction of:
Rubidoux Area II Street and Storm Drain Improvement Project

I in strict accordance with the plans and specifications dated, _____, prepared by Pettit, Inc., hereinafter called the "Engineer", including Addenda thereto as listed in the Contractor's Proposal, all of which are made a part hereof.

TIME FOR COMPLETION: The work shall be commenced on a date to be specified in a written order of the Engineer and shall be completed within two hundred ten (210) calendar days from and after said date. It is expressly agreed that except for extensions of time duly granted in the manner and for the reasons specified in the General Conditions, time shall be of the essence.

COMPENSATION TO BE PAID TO CONTRACTOR: The Owner agrees to pay and the Contractor agrees to accept in full consideration for the performance of the Contract, subject to additions and deductions as provided in the General Conditions, the sum of _____ Dollars (\$ _____), being the total of the Base Bid.

The sum is to be paid according to the schedule as provided in the General Conditions.

Pursuant to Labor Code Section 1861, the Contractor gives the following certifications: I am aware of the provisions of Section 3700 of the Labor Code which require every employer to be insured against liability for Worker's Compensation or to undertake self-insurance in accordance with the provisions of that code, and I will comply with such provisions before commencing the performance of the work of this Contract.

IN WITNESS WHEREOF, the parties hereto on the day and year first above written have executed this agreement in _____ counterparts.
Type of Contractor's organization

If other than individual or corporation, list names of all members who have authority to bind firm.

_____	_____	_____
_____	_____	_____
_____	_____	_____
_____	_____	_____

IF OTHER THAN CORPORATION EXECUTE HERE

Attest: _____ Firm Name _____
_____ Signature _____
_____ Address _____
Contractor's License No. _____

IF CORPORATION, FILL OUT FOLLOWING AND EXECUTE

Name of President of Corporation _____
Name of Secretary of Corporation _____
Corporation is organized under the laws of the state of _____
Firm Name _____
Signature _____
AFFIX SEAL Title of Office _____
Address _____
Contractor's License No. _____

Attest:

_____ Deputy
_____ Seal
_____ Owner
_____ Chairman, Board of Directors

PAYMENT BOND

(Public Work - Civil code Section 3247 et seq.)

The makers of this bond are _____, as Principal and Original Contractor, and _____, a corporation, authorized to issue Surety Bonds in California, as Surety, and this bond is issued in conjunction with that certain public works contract dated _____, between Principal and the Redevelopment Agency for the County of Riverside, a public entity, as Owner, for \$ _____, the total amount payable. THE AMOUNT OF THIS BOND IS 100% OF SAID SUM. Said contract is for pubic work generally consisting of _____.

The beneficiaries of this Bond are as is stated in 3248 of the Civil Code and the requirements and conditions of this Bond are as is set forth in Sections 3248, 3249, 3250 and 3252 of said Code. Without notice, Surety consents to extension of time for performance, change in requirements, amount of compensation, or repayment under said contract.

DATED:

Surety

Original Contractor - Principal
By _____

By _____
Its Attorney in Fact

Title _____
(If corporation , affix seal)

(Corporate Seal)

STATE OF CALIFORNIA)
COUNTY OF _____)

SURETYS ACKNOWLEDGMENT

On _____, before me personally appeared _____, known to me to be the person whose name is subscribed to the within instrument as attorney in fact of _____, a corporation, and acknowledged that he subscribed the name of said corporation thereto, and his own as its attorney in fact.

Notary Public (Seal)

Approved as to form:

Agency Counsel

PERFORMANCE BOND

The makers of this bond, _____, as Principal, and _____, as Surety, are held and firmly bound unto the Redevelopment Agency for the County of Riverside, hereinafter called the Owner, in the sum of \$ _____, _____ dollars for the payment of which sum well and truly to be made, we bind ourselves, our heirs, executors, administrators and successors, jointly and severally, firmly by these presents.

The condition of this obligation is such, that whereas the principal entered into a certain contract, hereto attached, with the Owner, dated _____, 20__, for the construction of: Rubidoux Area II Street and Storm Drain Improvement Project in accordance with plans and specifications, dated _____, 20__.

Now, therefore, if the principal shall well and truly perform and fulfill all the undertakings, covenants, terms, conditions and agreements of said contract during the original term of said contract and any extension thereof that may be granted by the Owner, with or without notice to the Surety, and during the life of any guaranty required under the contract, and shall also well and truly perform and fulfill all the undertakings, covenants, terms, conditions, and agreements of any and all duly authorized modifications of said contract that may hereafter be made, then this obligation to be void, otherwise to remain in full force and virtue. Without notice, Surety consents to extension of time for performance, change in requirements, change in compensation or prepayment under said contract.

DATED:

SURETY

By _____
Its Attorney in Fact

PRINCIPAL

By _____

Title _____
(If corporation, affix seal)

(NOTE: This bond must be executed by both parties, with corporate seals affixed. All signatures must be acknowledged. Attach acknowledgments.)

**CONTRACTOR'S CERTIFICATE REGARDING
WORKER'S COMPENSATION INSURANCE**

Section 3700 of the Labor Code provides, in part, as follows:

"Every employer except the State and all political subdivision or institutions thereof, shall secure the payment of compensation in one (1) or more of the following ways:

- a) by being insured against liability to pay compensation with one (1) or more insurers duly authorized to write compensation insurance in this State; or
- b) by securing from the Director of Industrial Relations, a Certificate of Consent to Self-insure, which may be given upon furnishing proof satisfactory to the Director of Industrial Relations of ability to self-insure and to pay any compensation that may become due to his employees ..."

The undersigned is aware of the provisions of Section 3700 of the Labor Code that requires every employer to be insured against liability for Worker's Compensation or to undertake self-insurance in accordance with the provisions of that Code, and will comply with such provisions before commencing the performance of the work of this Contract.

Signature: _____ Date: _____

Printed Name: _____ Title: _____

Company: _____

Address: _____

(In accordance with Article 5 [commencing at Section 1860], Chapter 1, Part 7, Division 2, of the Labor Code, the above Certificate must be signed by Contractor and filed with the awarding body prior to Contractor performing any work under this Contract.)

CONTRACTOR'S CERTIFICATE REGARDING
WORKER'S COMPENSATION INSURANCE

RIVERSIDE CONSTRUCTION COMPANY, INC.
P.O. Box 1146
RIVERSIDE, CA 92502

SEALED BID RECEIVED
CLERK OF THE BOARD OF SUPERVISORS

RECEIVED RIVERSIDE COUNTY
CLERK / BOARD OF SUPERVISORS

2011 JUN -6 PM 3:55

COUNTY OF RIVERSIDE
CLERK OF THE BOARD
4080 LEMON ST 1ST FLOOR
RIVERSIDE, CA 92501

PROPOSAL FOR THE CONSTRUCTION OF
RUBIDOUX, AREA 11 STREET AND STORM DRAIN IMPROVEMENT PROJECT