

**SUBMITTAL TO THE BOARD OF SUPERVISORS
COUNTY OF RIVERSIDE, STATE OF CALIFORNIA**

838A



FROM: TLMA - Transportation Department

SUBMITTAL DATE:
May 25, 2011

SUBJECT: Construction of street improvements for the Mecca Streets Revitalization Project - Phase 3, including 66th Avenue, Dale Kiler Road and Home Avenue, in the unincorporated community of Mecca.

RECOMMENDED MOTION: That the Board of Supervisors:

1. Approve the plans and specifications for the construction of street improvements for the Mecca Streets Revitalization Project - Phase 3, including 66th Avenue, Dale Kiler Road and Home Avenue, in the unincorporated community of Mecca.
2. Authorize the Clerk to advertise for bids to be received in the office of the Director of Transportation up to the hour of 2:00 pm, Wednesday, June 22, 2011, at which time bids will be opened.

Juan C. Perez
Director of Transportation

JCP:jrj:sb:cmw
(Continued On Attached Page)

FORM APPROVED COUNTY COUNSEL
 BY: MARSHAL L. VICTOR
 DATE: 5/19/11
 Departmental Concurrence

FINANCIAL DATA	Current F.Y. Total Cost:	\$ 1,672,600	In Current Year Budget:	No
	Current F.Y. Net County Cost:	\$ 0	Budget Adjustment:	No
	Annual Net County Cost:	\$ 0	For Fiscal Year:	2011/2012
SOURCE OF FUNDS: Redevelopment Agency funds (100%)				Positions To Be Deleted Per A-30 <input type="checkbox"/>
				Requires 4/5 Vote <input type="checkbox"/>

C.E.O. RECOMMENDATION:

APPROVE

BY:
Tina Grande

County Executive Office Signature

MINUTES OF THE BOARD OF SUPERVISORS

On motion of Supervisor Buster, seconded by Supervisor Ashley and duly carried, IT WAS ORDERED that the above matter is approved as recommended.

Ayes: Buster, Stone, Benoit and Ashley
 Nays: None
 Absent: Tavaglione
 Date: June 7, 2011
 xc: Transp., COB

Kecia Harper-Ihem
 Clerk of the Board
 By:
 Deputy

Prev. Agn. Ref. 11/3/2009 item 3.50 | District: 4 | Agenda Number:

8/31/2010 item 3.78

ATTACHMENTS FILED
 WITH THE CLERK OF THE BOARD

3.67

The Honorable Board of Supervisors

RE: Construction of street improvements for the Mecca Streets Revitalization Project - Phase 3, including 66th Avenue, Dale Kiler Road and Home Avenue, in the unincorporated community of Mecca.

May 25, 2011

Page 2 of 2

BACKGROUND: On November 3, 2009 (Item 3.50), the Board awarded a contract for the construction of street improvements for Phase 1 of the Mecca Streets Revitalization Project. That construction has been completed.

On August 31, 2010 (Item 3.78), the Board awarded a contract for the construction of street improvements for Phase 2 of the Mecca Streets Revitalization Project. That construction is in progress.

As a continuation of the street improvements in downtown Mecca, staff recommends that the Board advertise Phase 3 of the Mecca Streets Revitalization Project for the construction of street improvements on the following streets.

ROAD:	FROM:	TO:
66 th Avenue	West of Date Palm Street	Home Avenue
Dale Kiler Road	South of 66 th Avenue	2 nd Street
Home Avenue	66 th Avenue	2 nd Street

The improvements are intended to benefit the community by eliminating blight and by providing streets that will improve vehicular travel, pedestrian access and street drainage. The improvements will include the reconstruction of the existing pavement and the addition of sidewalk, curb, gutter and the replacement street lighting.

Construction of the Phase 3 street improvements will begin as soon as the Redevelopment Agency completes the construction of an 18" waterline in 66th Avenue. The completion of the street improvements is intended to coincide with the opening of the Mecca Boys and Girls Club.

The proposed work for the Phase 3 streets will be funded by the Redevelopment Agency under the terms and established budget of a cooperative agreement that will be submitted to the Board of Supervisors for execution prior to, or concurrent with, the award of the construction contract.

Subject to approval by the Board of Supervisors, additional future phases of construction are anticipated to bring street improvements to: 66th Avenue, 4th Street, 6th Street, 7th Street, Hammond Road, Lincoln Street, Coahuilla Street, Date Palm Street, Brown Street, Dale Kiler Road, Home Avenue and Frank J. Valdovino Road.

There will be no construction cost incurred until FY 2011/12

The submitted plans and specifications have been approved as to form by County Counsel.

Environmental clearance is complete.

Project No: C1-0646

MECCA STREETS REVITALIZATION PROJECT
PHASE 3

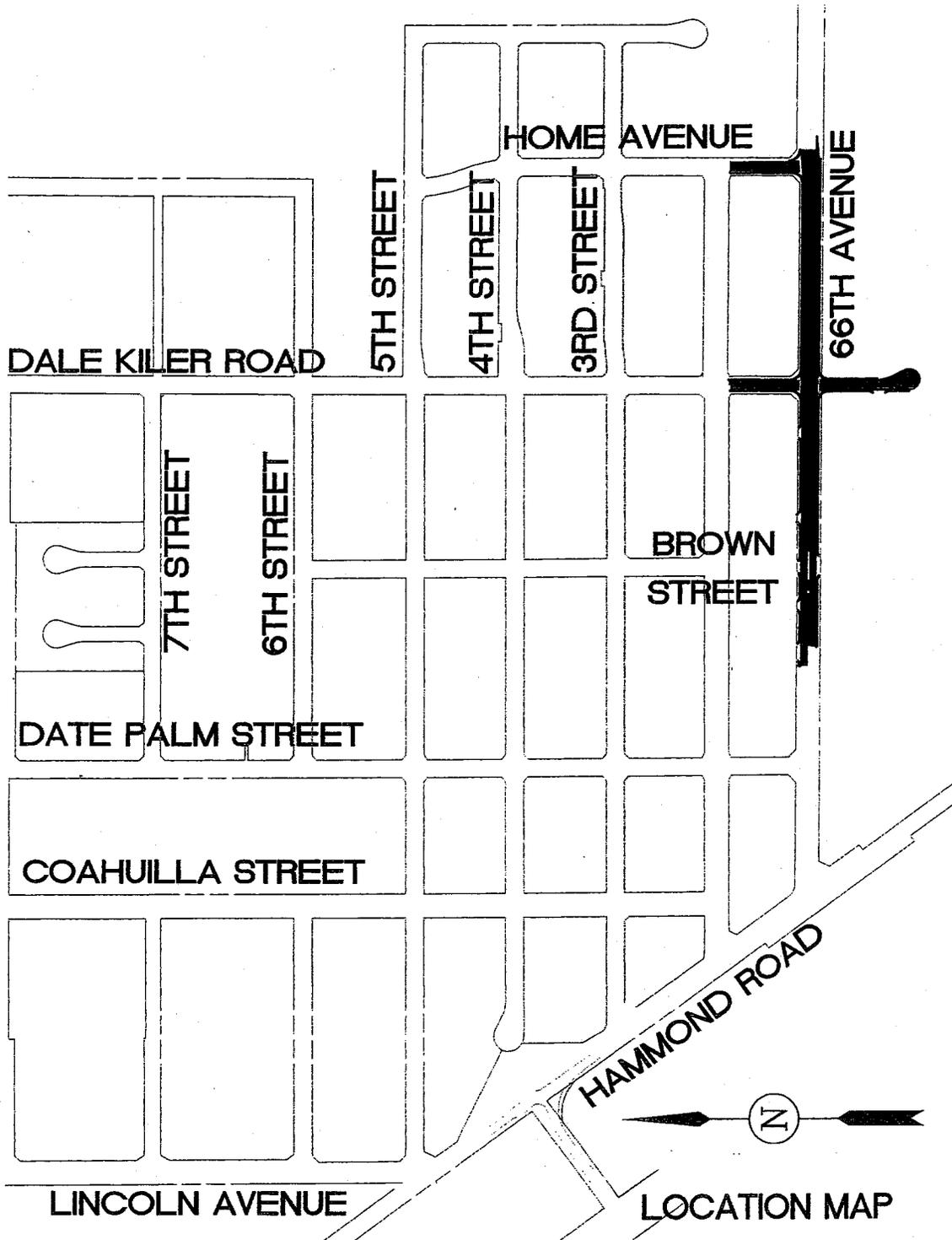



OFFICE OF
CLERK OF THE BOARD OF SUPERVISORS

1st FLOOR, COUNTY ADMINISTRATIVE CENTER
P.O. BOX 1147, 4080 LEMON STREET
RIVERSIDE, CA 92502-1147

PHONE: (951) 955-1060

FAX: (951) 955-1071

KECIA HARPER-IHEM
Clerk of the Board of Supervisors

KIMBERLY A. RECTOR
Assistant Clerk of the Board

June 8, 2011

THE PRESS ENTERPRISE
ATTN: LEGALS
PO BOX 792
RIVERSIDE, CA 92501

FAX (951) 368-9018
E-MAIL: legals@pe.com

**RE: NOTICE INVITING BIDS: MECCA STREETS REVITALIZATION PROJ. – PHASE 3
C1-0646**

To Whom It May Concern:

Attached is a copy for publication in your newspaper for **TEN (10) TIMES:**

Friday	- June 10, 2011	Wednesday	- June 15, 2011
Saturday	- June 11, 2011	Thursday	- June 16, 2011
Sunday	- June 12, 2011	Friday	- June 17, 2011
Monday	- June 13, 2011	Saturday	- June 18, 2011
Tuesday	- June 14, 2011	Sunday	- June 19, 2011

We require your affidavit of publication immediately upon completion of the last publication.

Your invoice must be submitted to this office in duplicate, WITH TWO CLIPPINGS OF THE PUBLICATION.

NOTE: PLEASE COMPOSE THIS PUBLICATION INTO A SINGLE COLUMN FORMAT.

Thank you in advance for your assistance and expertise.

Sincerely,

Mcgil

Cecilia Gil, Board Assistant to
KECIA HARPER-IHEM, CLERK OF THE BOARD

Gil, Cecilia

From: PE Legals <legals@pe.com>
Sent: Wednesday, June 08, 2011 8:31 AM
To: Gil, Cecilia
Subject: RE: FOR PUBLICATION: MECCA ST. C1-0646

Received for publication on 6/10-6/19

enterprise media
Publisher of The Press-Enterprise
Phone: 1.800.880.0345
Fax: 951.368.9018

From: Gil, Cecilia [mailto:CCGIL@rcbos.org]
Sent: Wednesday, June 08, 2011 8:19 AM
To: PE Legals
Subject: FOR PUBLICATION: MECCA ST. C1-0646

Good Morning! Attached is a Notice Inviting Bids, for publication from June 10 to June 19, 2011. Please confirm. THANK YOU!

Cecilia Gil

Board Assistant to the
Clerk of the Board of Supervisors
951-955-8464

THE COUNTY ADMINISTRATIVE CENTER IS CLOSED EVERY FRIDAY UNTIL FURTHER NOTICE.
PLEASE CONSIDER THE ENVIRONMENT BEFORE PRINTING.



OFFICE OF
CLERK OF THE BOARD OF SUPERVISORS
1st FLOOR, COUNTY ADMINISTRATIVE CENTER
P.O. BOX 1147, 4080 LEMON STREET
RIVERSIDE, CA 92502-1147
PHONE: (951) 955-1060
FAX: (951) 955-1071

KECIA HARPER-IHEM
Clerk of the Board of Supervisors

KIMBERLY A. RECTOR
Assistant Clerk of the Board

June 8, 2011

THE DESERT SUN
ATTN: LEGALS
PO BOX 2734
PALM SPRINGS, CA 92263

FAX (760) 778-4731
E-MAIL: legals@thedesertsun.com

**RE: NOTICE INVITING BIDS: MECCA STREETS REVITALIZATION PROJ. – PHASE 3
C1-0646**

To Whom It May Concern:

Attached is a copy for publication in your newspaper for **FIVE (5) TIMES:**

Wednesday	- June 15, 2011
Thursday	- June 16, 2011
Friday	- June 17, 2011
Saturday	- June 18, 2011
Sunday	- June 19, 2011

We require your affidavit of publication immediately upon completion of the last publication.

Your invoice must be submitted to this office in duplicate, WITH TWO CLIPPINGS OF THE PUBLICATION.

NOTE: PLEASE COMPOSE THIS PUBLICATION INTO A SINGLE COLUMN FORMAT.

Thank you in advance for your assistance and expertise.

Sincerely,

Mcgil

Cecilia Gil, Board Assistant to
KECIA HARPER-IHEM, CLERK OF THE BOARD

Gil, Cecilia

From: Moeller, Charlene <CMOELLER@palmspri.gannett.com>
Sent: Wednesday, June 08, 2011 9:37 AM
To: Gil, Cecilia
Subject: RE: FOR PUBLICATION: Mecca Sts. - C1-0646

Ad received and will publish on date(s) requested.

Charlene Moeller | Media Sales Legal Notice Coordinator
The Desert Sun Media Group
750 N. Gene Autry Trail, Palm Springs, CA 92262
t 760.778.4578 | f 760.778.4731
legals@thedesertsun.com | dpwlegals@thedesertsun.com
The Coachella Valley's #1 Source in News & Advertising!
www.mydesert.com | [@MyDesert](https://twitter.com/MyDesert) | [facebook MyDesert.com](https://facebook.com/MyDesert.com)

From: Gil, Cecilia [mailto:CCGIL@rcbos.org]
Sent: Wednesday, June 08, 2011 8:20 AM
To: tds-legals
Subject: FOR PUBLICATION: Mecca Sts. - C1-0646

Good Morning! Attached is a Notice Inviting Bids for publication from June 15 to June 19, 2011. Please confirm. THANK YOU!

Cecilia Gil
Board Assistant to the
Clerk of the Board of Supervisors
951-955-8464

**THE COUNTY ADMINISTRATIVE CENTER IS CLOSED EVERY FRIDAY UNTIL FURTHER NOTICE.
PLEASE CONSIDER THE ENVIRONMENT BEFORE PRINTING.**

NOTICE INVITING BIDS

County of Riverside, herein called Owner, invites sealed proposals for reconstruction of:

MECCA STREETS REVITALIZATION PROJECT – PHASE 3 66TH AVENUE, DALE KILLER ROAD AND HOME AVENUE

PROJECT No. C1-0646

Proposal shall be delivered to the Riverside County Transportation Department, 14th Street Annex, 3525 14th Street, Riverside, California 92501, telephone (951) 955-6780 not later than 2:00 p.m., on **Wednesday, June 22, 2011**, to be promptly opened in public at said address. Each proposal shall be in accordance with plans, specifications, and other contract documents, dated **May 2011**, and prepared by County of Riverside, whose address is same as the above, from whom they may be obtained upon deposit of **\$30.00** per set plus mailing. No refund. Prospective bidders may preview the plans, specifications and other contract documents, at no charge prior to purchase, at the above noted location.

The Contractor is required to have a Class "A" license or C-12 license at the time of bid submission.

Engineering Estimate	\$1,500,000.00 - \$1,800,000.00
Bid Bond	10%
Performance Bond	100%
Payment Bond	100%
Working Days	30

www.tlma.co.riverside.ca.us/trans

Dated: June 8, 2011

Kecia Harper-Ihem, Clerk of the Board
By: Cecilia Gil, Board Assistant

THE PRESS-ENTERPRISE **PE.com**

THE BUSINESS PRESS **SoCal**
Commercial Printing

LA PRENSA WEEKLY

8-MEDIA waves

LANDSOCAL

LA PRENSA WEEKLY

HS

① BILLING PERIOD 06/19/11 - 06/20/11
 ② ADVERTISING/CLIENT NAME BOARD OF SUPERVISORS
 ⑤ BILLING DATE 06/20/11
 FOR BILLING INFORMATION CALL (951) 368-9713
 ④ PAGE NO 1
 ③ TOTAL AMOUNT DUE 1,004.30
 * UNAPPLIED AMOUNT ⑦ TERMS OF PAYMENT Due Upon Receipt

⑨ REMITTANCE ADDRESS
 POST OFFICE BOX 12009
 RIVERSIDE, CA 92502-2209

⑩ BILLED ACCOUNT NAME AND ADDRESS
 BOARD OF SUPERVISORS
 COUNTY OF RIVERSIDE
 P.O. BOX 1147
 RIVERSIDE CA 92502

⑥ BILLED ACCOUNT NUMBER 045202
 REP NO LE04

Statement #: 56600288 Amount Paid \$ _____ Your Check # _____

PLEASE DETACH AND RETURN UPPER PORTION WITH YOUR REMITTANCE

⑩ DATE	⑪ REFERENCE	⑫ ⑬ ⑭ DESCRIPTION-OTHER COMMENTS/CHARGES	⑮ SAU SIZE ⑯ BILLED UNITS	⑰ RATE	⑱ GROSS AMOUNT	⑳ NET AMOUNT
06/10	4305394 CO	NIB - MECCA ST PROJECT NO. C1- Class : 10 Ctext Ad# 10687727 Placed By : Cecilia Gil	83 L	1.30		107.90
06/11	4305394 CO	NIB - MECCA ST PROJECT NO. C1- Class : 10 Ctext Ad# 10687727 Placed By : Cecilia Gil	83 L	1.20		99.60
06/12	4305394 CO	NIB - MECCA ST PROJECT NO. C1- Class : 10 Ctext Ad# 10687727 Placed By : Cecilia Gil	83 L	1.20		99.60
06/13	4305394 CO	NIB - MECCA ST PROJECT NO. C1- Class : 10 Ctext Ad# 10687727 Placed By : Cecilia Gil	83 L	1.20		99.60
06/14	4305394 CO	NIB - MECCA ST PROJECT NO. C1- Class : 10 Ctext Ad# 10687727 Placed By : Cecilia Gil	83 L	1.20		99.60
06/15	4305394 CO	NIB - MECCA ST PROJECT NO. C1- Class : 10 Ctext Ad# 10687727 Placed By : Cecilia Gil	83 L	1.20		99.60
06/16	4305394 CO	NIB - MECCA ST PROJECT NO. C1- Class : 10 Ctext Ad# 10687727 Placed By : Cecilia Gil	83 L	1.20		99.60
06/17	4305394 CO	NIB - MECCA ST PROJECT NO. C1- Class : 10 Ctext Ad# 10687727 Placed By : Cecilia Gil	83 L	1.20		99.60
06/18	4305394 CO	NIB - MECCA ST PROJECT NO. C1- Class : 10 Ctext Ad# 10687727 Placed By : Cecilia Gil	83 L	1.20		99.60
06/19	4305394 CO	NIB - MECCA ST PROJECT NO. C1- Class : 10 Ctext Ad# 10687727 Placed By : Cecilia Gil	83 L	1.20		99.60

RECEIVED BY ENTERPRISE MEDIA
 BANK/BOARD OF SUPERVISORS
 2011 JUN 28 PM 4:47

*Transp.
3.67 of 06/07/11*

② CURRENT NET AMOUNT DUE	③ 30 DAYS	④ 60 DAYS	⑤ OVER 90 DAYS	* UNAPPLIED AMOUNT	⑧ PLEASE PAY THIS AMOUNT 1,004.30
--------------------------	-----------	-----------	----------------	--------------------	--------------------------------------

enterprise media
 THE PRESS-ENTERPRISE **PE.com**
 P.O. BOX 12009
 RIVERSIDE, CA 92502-2209
 FAX (951) 368-9026

ADVERTISING STATEMENT/INVOICE

* UNAPPLIED AMOUNTS ARE INCLUDED IN TOTAL AMOUNT DUE



③ STATEMENT NUMBER		⑦ ADVERTISER INFORMATION			
①	②	③	④	⑤	⑥
56600288	06/19/11 - 06/20/11	045202			BOARD OF SUPERVISORS

THE PRESS-ENTERPRISE

3450 Fourteenth Street
Riverside CA 92501-3878
951-684-1200
951-368-9018 FAX

**PROOF OF PUBLICATION
(2010, 2015.5 C.C.P.)**

Press-Enterprise

PROOF OF PUBLICATION OF

Ad Desc.: NIB - MECCA ST PROJECT NO. C1-0646

I am a citizen of the United States. I am over the age of eighteen years and not a party to or interested in the above entitled matter. I am an authorized representative of THE PRESS-ENTERPRISE, a newspaper of general circulation, printed and published daily in the County of Riverside, and which newspaper has been adjudicated a newspaper of general circulation by the Superior Court of the County of Riverside, State of California, under date of April 25, 1952, Case Number 54446, under date of March 29, 1957, Case Number 65673 and under date of August 25, 1995, Case Number 267864; that the notice, of which the annexed is a printed copy, has been published in said newspaper in accordance with the instructions of the person(s) requesting publication, and not in any supplement thereof on the following dates, to wit:

06-10-11
06-11-11
06-12-11
06-13-11
06-14-11
06-15-11
06-16-11
06-17-11
06-18-11
06-19-11

I Certify (or declare) under penalty of perjury that the foregoing is true and correct.

Date: Jun. 19, 2011
At: Riverside, California



BOARD OF SUPERVISORS
P.O. BOX 1147
COUNTY OF RIVERSIDE
RIVERSIDE CA 92502

Ad #: 10687727

PO #:

Agency #: _____

Ad Copy:

NOTICE INVITING BIDS

County of Riverside, herein called Owner, invites sealed proposals for reconstruction of:

**MECCA STREETS REVITALIZATION PROJECT -
PHASE 3
66TH AVENUE, DALE KILLER ROAD AND HOME
AVENUE**

PROJECT No. C1-0646

Proposal shall be delivered to the Riverside County Transportation Department, 14th Street Annex, 3525 14th Street, Riverside, California 92501, telephone (951) 955-6780 not later than 2:00 p.m., on **Wednesday, June 22, 2011**, to be promptly opened in public at said address. Each proposal shall be in accordance with plans, specifications, and other contract documents, dated **May 2011**, and prepared by County of Riverside, whose address is same as the above, from whom they may be obtained upon deposit of \$30.00 per set plus mailing. No refund. Prospective bidders may preview the plans, specifications and other contract documents, at no charge prior to purchase, at the above noted location.

The Contractor is required to have a Class "A" license or C-12 license at the time of bid submission.

Engineering Estimate	\$1,500,000.00 - \$1,800,000.00
Bid Bond	10%
Performance Bond	100%
Payment Bond	100%
Working Days	30

www.tlma.co.riverside.ca.us/trans

Dated: June 8, 2011
Kecia Harper-Ihem,
Clerk of the Board
By: Cecilia Gil,
Board Assistant 6/10-6/19

The Desert Sun

mydesert.com

750 N. Gene Autry Trail
 Palm Springs, CA 92262
 Billing Inquiries: (866) 875-0854
 Main Office: (760) 322-8889

ADVERTISING INVOICE/STATEMENT

Make Checks payable to DESERT SUN PUBLISHING CO.
 P.O. Box 677368 Dallas, TX 75267-7368
 A finance charge of 1.5% per month(18% Annually) will be added to balances not paid by the 20th.

RIV06900000000000000000000040747940070144810821

92

RIVERSIDE COUNTY-BOARD OF SUP.
 PO BOX 1147
 RIVERSIDE CA 92502-1147

Customer No.	Invoice No.
RIV069	0004074794
For the Period	Thru
05/30/11	06/26/11
Due Date	Amount Due
07/15/11	7,014.48
AMOUNT PAID	

PLEASE RETURN THIS TOP SECTION WITH PAYMENT IN THE ENCLOSED ENVELOPE AND INCLUDE YOUR CUSTOMER NUMBER ON REMITTANCE.

Date	EDT	Class	Description	Times Run	Col	Depth	Total Size	Rate	Amount
0530			BALANCE FORWARD						6,259.36
0617			PAYMENT - THANK YOU						3,134.86-
0528	CLS	0001	CECILIA NO 1827 NOTICE I	4	2	63.00	504.00		215.16
0603	CLS	0001	CECILIA NO 1882 BOARD OF	2	2	120.00	480.00		215.20
0605	CLS	0001	CECILIA NO 1921 NOTICE O	4	2	158.00	1264.00		540.56
0611	CLS	0001	CECILIA NO 2004 NOTICE O	4	2	105.00	840.00		364.60
0615	CLS	0001	CECILIA NO 2018 NOTICE	10	2	47.00	940.00		406.10
0617	CLS	0001	CECILIA NO 2066 BOARD OF	2	2	183.00	732.00		319.78
0617	CLS	0001	CECILIA NO 2067 BOARD OF	2	2	715.00	2860.00		1,202.90
0617	CLS	0001	CECILIA NO 2065 NOTICE O	2	2	87.00	348.00		160.42
0622	CLS	0001	CECILIA NO 2110 BOARD OF	2	2	157.00	628.00		276.62
0622	CLS	0001	CECILIA NO 2111 NOTICE O	2	2	104.00	416.00		188.64
									2011 JUL -7 PM 5:52
Current		Over 30 Days	Over 60 Days	Over 90 Days	Over 120 Days	Total Due			
3,099.48		3,915.00	.00	.00	.00	7,014.48			
Contract Type	Contract Qnty.	Expiration Date	Current Usage	Total Used	Quantity Remaining	Salesperson			
						MOELLER			

3.67 of 06/07/11

The Advertiser shall make payment within 15 days of the billing date indicated on Company's statement, and, in the event that it fails to make payment within such time, Company may reject advertising copy and / or immediately cancel this contract and Advertiser agrees to indemnify Company for all expenses incurred in connection with the collection of amounts payable under this contract, including but not limited to collection fees, attorney's fees and court costs. If this agreement is cancelled due to Advertiser's failure to make timely payment, Company may rebill the Advertiser for the outstanding balance due at the open or earned contract rate, whichever is applicable.

TO ENSURE PROPER CREDIT, PLEASE RETURN THE TOP SECTION AND INCLUDE YOUR CUSTOMER NUMBER ON REMITTANCE.

Customer Number	Name	Invoice Number	Amount Paid
RIV069	RIVERSIDE COUNTY-BOARD OF SUP.	0004074794	

The Desert Sun
750 N Gene Autry Trail
Palm Springs, CA 92262
760-778-4578 / Fax 760-778-4731

Certificate of Publication

State Of California ss:
County of Riverside

Advertiser:

RIVERSIDE COUNTY-BOARD OF SUP.
4080 LEMON ST
RIVERSIDE CA 925013

2000267140

I am over the age of 18 years old, a citizen of the United States and not a party to, or have interest in this matter. I hereby certify that the attached advertisement appeared in said newspaper (set in type not smaller than non pariel) in each and entire issue of said newspaper and not in any supplement thereof on the following dates, to wit:

Newspaper: .The Desert Sun

6/15/2011	6/16/2011	6/17/2011
6/18/2011	6/19/2011	

I acknowledge that I am a principal clerk of the printer of The Desert Sun, printed and published weekly in the City of Palm Springs, County of Riverside, State of California. The Desert Sun was adjudicated a newspaper of general circulation on March 24, 1988 by the Superior Court of the County of Riverside, State of California Case No. 191236.

I declare under penalty of perjury that the foregoing is true and correct. Executed on this 19th day of June, 2011 in Palm Springs, California.

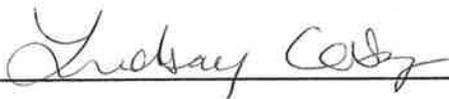

Declarant's Signature

No 2018

NOTICE INVITING BIDS

County of Riverside, herein called Owner, invites sealed proposals for reconstruction of:

**MECCA STREETS REVITALIZATION
PROJECT - PHASE 3
66TH AVENUE, DALE KILLER ROAD AND
HOME AVENUE**

PROJECT No. C1-0646

Proposal shall be delivered to the Riverside County Transportation Department, 14th Street Annex, 3525 14th Street, Riverside, California 92501, telephone (951) 955-6780 not later than 2:00 p.m., on Wednesday, June 22, 2011, to be promptly opened in public at said address. Each proposal shall be in accordance with plans, specifications, and other contract documents, dated May 2011, and prepared by County of Riverside, whose address is same as the above, from whom they may be obtained upon deposit of \$30.00 per set plus mailing. No refund. Prospective bidders may preview the plans, specifications and other contract documents, at no charge prior to purchase, at the above noted location.

The Contractor is required to have a Class "A" license or C-12 license at the time of bid submission.

Engineering Estimate	\$1,500,000.00
\$1,500,000.00	
Bid Bond	10%
Performance Bond	100%
Payment Bond	100%
Working Days	30

www.tma.co.riverside.ca.us/trans

Dated: June 8, 2011
Kecia Harper-Inem, Clerk of the Board
By: Cecilia Gil, Board Assistant

Published: 6/15 thru 6/19/2011

Clerk of the Board

SPECIFICATIONS and CONTRACT DOCUMENTS

for the

CONSTRUCTION

of

MECCA STREETS REVITALIZATION PROJECT- PHASE 3
66TH AVENUE, DALE KILLER ROAD AND HOME AVENUE

PROJECT NO. C1-0646



TRANSPORTATION DEPARTMENT

JUN 07 2011 3.07 pfs

FORM APPROVED COUNTY COUNSEL
BY Marshall Victor 5/19/11
MARSHALL VICTOR DAT

**MECCA STREETS REVITALIZATION PROJECT- PHASE 3
66TH AVENUE, DALE KILLER ROAD AND HOME AVENUE**

PROJECT NO. C1-0646

SPECIFICATIONS AND CONTRACT DOCUMENTS

for the construction of

**MECCA STREETS REVITALIZATION PROJECT – PHASE 3
66th AVENUE, DALE KILER ROAD AND HOME AVENUE**

COUNTY OF RIVERSIDE

Project No. C1-0646 (Construction), X1002 (Design)

Contract Approvals:

Recommended by:



Catherine M. Wampler,
Senior Civil Engineer

4/26/2011
Date

Approved by:

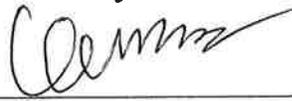

Khalid Nasim,
Engineering Division Manager

5/5/11
Date

SPECIFICATIONS AND CONTRACT DOCUMENTS

for the construction of

**MECCA STREETS REVITALIZATION PROJECT – PHASE 3
66th AVENUE, DALE KILER ROAD AND HOME AVENUE**

COUNTY OF RIVERSIDE

Project No. C1-0646 (Construction), X1002 (Design)

Engineering Certification:

These specifications, Special Provisions, and estimates have been prepared by or under the direction of the following Registered Civil Engineer:



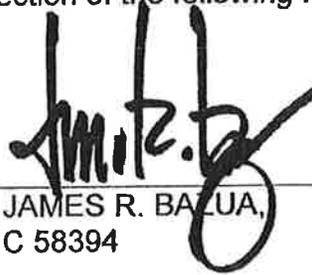

JAMES R. BAZUA,
C 58394

4/29/11
Date

TABLE OF CONTENTS

	<u>PAGE</u>
Notice Inviting Bids	
Instruction to Bidders	A1-A6
Contractor's Proposal	B1-B5
Non-Collusion Affidavit	B6-B8
Bid Bond	B9
Agreement	C1-C3
Performance Bond	C4
Payment Bond	C5
General Conditions	1-21
Definitions	1
Standard Specifications	1
Director of Transportation	2
Site Inspection	3
Protection of Premises	4
Change Orders	5
Substitution of Equals	6
Final Inspection - Notice of Completion	7
Termination of Contracts	7
Payments and Monthly Estimates	8
Force Account Payment	9
Final Payment	9
Damages	10
Documents of Contractor	10
Responsibility of Contractor in Emergency	11
Labor Code	11
Obstructions	12
Insurance - Hold Harmless	12
Equal Employment Opportunity	14
Deposit of Securities	16
Assignment of Claims	16
Claims Resolution	17
Dust Abatement	18
AQMD Requirements	22-47
Special Provisions	48-107
Appendix A (Attachment "C", Risk Level 1)	1-13 Pages
Reference Drawings	

Table of Contents Continued

SPECIAL PROVISIONS	48
DESCRIPTIONS:	48
SPECIFICATIONS:	48
DISPOSAL OF EXCESS EXCAVATION OR MATERIALS:	48
RECORD DRAWINGS:	49
LIQUIDATED DAMAGES:	50
INSURANCE:	50
CONSTRUCTION SCHEDULE AND COOPERATION WITH UTILITY COMPANIES:	51
ITEMS OF WORK:	52
TRAFFIC CONTROL SYSTEM:	52
PROGRESS PAYMENTS:	54
CLEARING AND GRUBBING:	55
MOBILIZATION:	56
DEVELOP WATER SUPPLY:	56
WATER POLLUTION CONTROL (WHITEWATER - RISK LEVEL 1):	57
STREET SWEEPING:	64
ROADWAY EXCAVATION:	66
FINISHING ROADWAY:	67
AGGREGATE BASE:	67
HOT MIX ASPHALT:	68
COMPENSATION ADJUSTMENTS FOR PRICE INDEX FLUCTUATIONS:	78
SUBGRADE ENHANCEMENT TREATMENT:	80
MECHANICALLY STABILIZED LAYER (GEOGRID)	81
CONCRETE CURB, GUTTER, CROSS-GUTTER, DRIVEWAY, COMMERCIAL DRIVEWAY, SIDEWALK, BUS PAD AND CURB RAMPS:	84
DECORATIVE STAMPED CONCRETE (MEDIAN HARDSCAPE):	86
REMOVE EXISTING FENCE/GATE/WALL AND REPLACE WITH TUBULAR STEEL FENCE:	90
THERMOPLASTIC CROSSWALK AND PAVEMENT MARKING:	91

PAINT TRAFFIC STRIPE: 92
PAVEMENT MARKERS (REFLECTIVE): 93
ROADSIDE SIGNS (INSTALL/RELOCATE): 93
PEDESTRIAN BARRICADE: 95
MODIFY EXISTING ADA RAMP WITH DETECTABLE WARNING SURFACE: 95
MISCELLANEOUS DIRECTED WORK: 95
LIGHTING: 96
SOLAR POWERED FLASHING BEACON SYSTEM: 98
OBSTRUCTIONS: 102

NOTICE INVITING BIDS

County of Riverside, herein called Owner, invites sealed proposals for reconstruction of:

**MECCA STREETS REVITALIZATION PROJECT - PHASE 3
66TH AVENUE, DALE KILLER ROAD AND HOME AVENUE**

PROJECT NO. C1-0646

Proposal shall be delivered to the Riverside County Transportation Department, 14th Street Annex, 3525 14th Street, Riverside, California 92501, telephone (951) 955-6780 not later than 2:00 p.m., on Wednesday, June 22, 2011, to be promptly opened in public at said address. Each proposal shall be in accordance with plans, specifications, and other contract documents, dated May 2011, and prepared by County of Riverside, whose address is same as the above, from whom they may be obtained upon deposit of \$30.00 per set plus mailing. No refund. Prospective bidders may preview the plans, specifications and other contract documents, at no charge prior to purchase, at the above noted location.

The Contractor is required to have a Class "A" license or C-12 license at the time of bid submission.

Dated: June 7, 2011

Kecia Harper-Ihem, Clerk of the Board

By: _____
Deputy

INSTRUCTIONS TO BIDDERS

1. Form of Proposal. The proposal must be made on the form of Contractor's Proposal which is included in the Contract Documents and must be completely filled in, dated and signed. If provision is made for alternates, they must all be bid, unless otherwise provided in the Special Provisions.
2. Bid Bond. The proposal must be accompanied by a 10% Bid Bond, using the form provided in the Contract Documents, or by a certified or cashier's check payable to the order of County in an amount not less than 10% of the amount bid, inclusive of alternates.
3. Submission of Proposal. A proposal must be submitted in a sealed opaque envelope which clearly identifies the bidder and the project. Bids must be received by the time and at the place set forth in the Notice Inviting Bids and may be withdrawn only as stated in the proposal. Bids shall be completed in ink.
4. Contract Documents. The complete Contract Documents are identified in the Agreement. Potential bidders are cautioned that the successful bidder incurs duties and obligations under all of the Contract Documents and that they should not merely examine the Plans and Specifications in making their bid.
5. License. To be considered for award of the contract, a potential bidder must have the kind of license required under provisions of the California Business and Professions Code for the work covered in this proposal. This includes joint ventures.

Each item of work will be performed by a Contractor which is qualified and properly licensed for that work.

Pursuant to California Labor Code Section 3099, certification is required for all persons who perform work as electricians for Contractors licensed as Class C-10 Electrical Contractors. Proof of certification shall be provided to the County before the start of construction.

6. Quantities. The amount of work to be done or materials to be furnished under the Contract as shown in the Contractor's Proposal are but estimates and are not to be taken as an expressed or an implied statement that the actual amount of work or materials will correspond to the estimate.

County reserves the right to increase or decrease or to entirely eliminate certain items from the work or materials to be furnished if such action is found to be desirable or expedient.

Contractor is cautioned against the unbalancing of his bid by prorating his overhead only into one or two items when there are a number of items listed in the schedule.

7. Interpretation of Documents. Discrepancies, omissions, ambiguities, requirements likely to cause disputes between trades and similar matter shall be promptly brought to the attention of the County of Riverside in writing. When appropriate, Addenda will be issued by County.

If the Bidder requires clarification or interpretation of the Bidding Documents, the Bidder shall make a written request to the County by a Request for Information (RFI). All requests for information must be submitted, in writing, between the hours of 8:00 AM and 5:00 PM on any day, Monday through Friday (except holidays), up to, including and no later than the fifth (5th) day prior to Bid Closing Deadline, by hand delivery, mail, fax or electronic mail. The County of Riverside will not respond to Requests for Information submitted after that time, unless the County determines, at its sole discretion, which it is in the best interest of the public and the County to do so. Requests for Information should be addressed to: County of Riverside, Transportation Department, Attn: Joel Jimenez; 3525 14th Street, Riverside, CA 92501, facsimile (951) 955-3164, electronic mail: jjjimenez@rctlma.org

No communication by anyone as to such matters except by an Addendum affects the meaning or requirements of the Contract Documents.

8. Addenda. County reserves the right to issue Addenda to the Contract Documents at any time prior to the time set to open bids. Each potential bidder shall leave with the County Transportation Department his name and address for the purpose of receiving Addenda to be mailed or delivered to such names at such addresses. To be considered, a Contractor's Proposal must list and take into account all issued Addenda.
9. Inspection of Site. Bidders must examine the site and acquaint themselves with all conditions affecting the work. By making his bid a bidder warrants that he has made such site examination as he deems necessary as to the condition of the site, its accessibility for materials, workmen and utilities and ability to protect existing surface and subsurface improvements. No claim for allowances - time or money - will be allowed as to such matters.
10. Bonds. The County requires a 100% Payment Bond and 100% Performance Bond from the successful bidder. All Bonds must be on County's forms contained in the Contract Documents.

The bonds must be underwritten by a Surety Company, which is admitted to transact the business of insurance in the State of California, and which carries a rating in the current issue of Best's Insurance Guide of "A" or better with a financial size of at least "VIII". The bond forms included in the project documents shall be used. All signatures on the bonds shall be notarized. Bonds shall be provided with an executed Power of Attorney issued by the surety.

11. Bids. Bids are required for the entire work, including all alternate bid schedules, if applicable, unless otherwise explicitly allowed in the bid documents. The amount of the bid for comparison purposes will be the total of all items. The total of unit basis items will be determined by extension of the item price bid on the basis of the estimated quantity set forth for the item.

The bidder shall set forth for each item of work in clearly legible figures, an item price and a total for the item in the respective spaces provided for this purpose. In the case of unit basis items, the amount set forth under the "Total" column shall be the extension of the item price bid on the basis of the estimated quantity for the item.

In case of discrepancy between the item price and the total set forth for the item, the item price shall prevail, provided, however, if the amount set forth as an item price is ambiguous, unintelligible or uncertain for any cause, or is omitted, or in the case of unit basis items, is the same amount as the entry in the "Total" column, then the amount set forth in the "Total" column for the item shall prevail in accordance with the following:

- a. As to lump sum items, the amount set forth in the "Total" column shall be the item price.
- b. As to unit basis items, the amount set forth in the "Total" column shall be divided by the estimated quantity for the item and the price thus obtained shall be the item price.

The bidder is advised that the items of work may be grouped into bid schedules, and that certain bid items may be listed in more than one bid schedule, and with different bid item numbers, and the following shall apply thereto:

The bidder is directed to submit the same bid amount for all contract bid items that are listed with the same item code and item description. Said bid items are referred to herein as "Like Bid Items".

"Like Bid Items" shall be considered a single bid item for purposes of calculating increased and decreased quantities, and as otherwise applicable in Section 4-1.03, "Changes" of the Standard Specifications.

The following are not subject to this bidding requirement:

1. Bid items with the same item code but different item descriptions.
2. Bid items that are measured as "lump sum" or "force account".
3. Alternate bid schedules.

In the event that a bidder submits different unit bid amounts for "Like Bid Items", as described above, the bid will be corrected by applying the lowest of the unit bid amounts to all the respective "Like Bid Items".

No bidder may withdraw his bid for a period of ninety (90) days after the bid opening.

12. Award of Contract. The County reserves the right to reject all bids received. Acceptance by the governing body of the County by resolution or minute order at a meeting regularly called

and held of a Contractor's Proposal constitutes an award of the contract and the execution of the Agreement is a written memorial thereof.

The County of Riverside will submit the contract documents to the low responsive and responsible bidder for execution prior to award utilizing the following procedures and requirements:

- a. A bidder whose proposal is accepted shall execute the formal construction agreement with the County of Riverside, similar to the form attached hereto as a sample, and shall return said agreement, together with approved performance and payment bonds and with complete evidence of insurance as required elsewhere herein, including executed additional insured endorsements and waivers of subrogation, within ten (10) working days from the date of the Notice of Acceptance of Proposal and Intent to Award as issued by the Transportation Department. All submittals shall meet the requirements of the bid documents. Corrections, if required, shall be made and the revised documents shall be resubmitted within two (2) working days of Contractor's receipt of review comments.
 - b. The contract bonds and insurance documentation shall be submitted in accordance with the contract requirements prior to submission to the County of Riverside Board of Supervisors for award by the Transportation Department, and prior to the performance of any work under the contract.
 - c. If a Bidder to whom a Notice of Acceptance of Proposal and Intent to Award has been issued, fails or refuses to sign a construction agreement, or to furnish the bonds or insurance certificates and endorsements as required within the prescribed period of time as described above, the County of Riverside may, at its sole discretion, rescind the Notice of Acceptance, and the bid guarantee submitted by that Contractor shall become the property of the County of Riverside as prescribed in the bid documents and as allowed by law.
 - d. If it is in the best interest of the County of Riverside, the County reserves the right to award the contract prior to execution by the Contractor. Thereafter, County shall mail or deliver to the lowest responsible bidder the agreement for Contractor's execution and return.
13. Return of Guarantee. Bid bonds will not be returned unless specifically requested by the bidder. Any submitted negotiable securities of unsuccessful bidders will be returned by mail within 30 days of the award of a contract to the successful bidder. Any submitted negotiable security of the successful bidder will be returned by mail within 30 days of receipt by the County of executed contract, certificate of insurance, performance bond and payment Bond.
14. Subletting and Subcontracting. Bidders are required pursuant to the Subletting and Subcontracting Fair Practices Act (commencing with Section 4100 of the Public Contracts Code) to list in their proposal the name and location of place of business of each subcontractor who will perform work or labor or render services in or about the construction

of the work or improvement or a subcontractor who specifically fabricates and installs a portion of the work or improvement according to detailed drawings contained in the Plans and Specifications in excess of 1/2 of 1% of this prime Contractor's total bid. Failure to list a subcontractor for a portion of the work means that the prime Contractor will do that portion of the work. It is the County's intent for the Subletting and Subcontracting Fair Practice Act to apply to all phases of the work.

15. Qualifications of Bidders. No award will be made to any bidder who cannot give satisfactory assurance to the Board of Supervisors as to his own ability to carry out the contract, both from his financial standing and by reason of his previous experience as a Contractor on work of the nature contemplated in the contract. The bidder may be required to submit his record of work of similar nature to that proposed under these specifications, and unfamiliarity with the type of work may be sufficient cause for rejection of bid.
16. Contract Participation. Riverside County's M/W/DVBE Contract Participation Program affirms the utilization and participation of qualified minority, women and disabled veteran firms in its contracting and procurement activities. The County encourages general and prime Contractors to afford competitive subcontracting opportunities to minority, women and disabled veteran firms where possible, in their contracting and procurement activities with the County of Riverside.
17. Hours of Work. Attention is directed to Section 8-1.06, "Time of Completion" and Section 7-1.01A (1), "Hours of Labor" of the Standard Specifications.

Daily working hours shall be between the hours of 7:00 a.m. and 6:00 p.m., Monday through Friday, except legal holidays, as approved by the Engineer. Exceptions and specific work schedules shall be submitted to the Engineer for consideration.

18. Labor Code. Pursuant to the Labor Code, the governing board of the Owner has obtained from the Director of the Department of Industrial Relations, State of California, his determinations of general prevailing rates of per diem wages applicable to the work, and for holiday, and overtime work, including employer payments for health and welfare, pensions, vacation and similar purpose, as set forth on schedule which is on file at the principal office of the Owner, and which will be made available to any interested person upon request.
19. Alternate Bid Schedules. If the Proposal includes bid items listed under a Base Bid Schedule and one or more Alternate Bid Schedules, the following shall apply: The County may award only the items of work listed on the Base Bid Schedule, or may choose to award some or all of the Alternate Bid Schedules in addition to the Base Bid Schedule. Unless otherwise specified, the basis of the selection of the lowest bid shall be the lowest responsive and responsible bid for the sum of all Bid Schedules.

If the Proposal includes bid items listed under two or more Alternate Bid Schedules with no Base Bid Schedule, the following shall apply: This project contains Alternate Bid Schedules that may or may not be mutually exclusive, as described elsewhere in the bid documents. The County may award the items of work listed on one or more of the Alternate Bid

Schedules. In the case of mutually exclusive Alternate Bid Schedules, only one of the Alternate Bid Schedules will be selected for award. Unless otherwise specified, the basis of the selection of the lowest bid shall be the lowest responsive and responsible bid for the sum of all Bid Schedules.

The County also reserves the right to reject all bids received.

20. Dust Abatement. Attention is directed to Section 23, "Dust Abatement" with regard to the dust abatement provisions of the contract.
21. Submission of Insurance Certificate. Within ten (10) working days of the date of the Notice of Acceptance of Proposal and Intent to Award issued by the County of Riverside, the successful Contractor shall submit a certificate of insurance, including required endorsements, which provides evidence that the bidding Contractor has insurance coverage that meets the requirements of Section 18 of the General Conditions. Failure to have complete insurance coverage in place and to provide all required certificates and endorsements within the specified ten (10) working days period will be grounds for declaring the bidder to not be in compliance with the bid documents, rescinding the Notice of Acceptance, making a claim against the bid bond, and awarding to the second low bidder, at the sole discretion of the County.

CONTRACTOR' S PROPOSAL

TO: COUNTY OF RIVERSIDE

DATE: _____

hereafter called "County":

BIDDER: _____
(hereafter called "Contractor")

THE UNDERSIGNED, Contractor, having carefully examined the site and the Contract Documents for the construction of MECCA STREETS REVITALIZATION PROJECT- PHASE 3, 66TH AVENUE, DALE KILLER ROAD, AND HOME AVENUE, Project No. C1-0646 hereby proposes to construct the work in accordance with the Contract Documents, including Addenda Nos. _____ for the amount stated in this Proposal.

By submitting this Proposal, Contractor agrees with County:

1. That unless withdrawn in person by Contractor or some person authorized in writing by Contractor not by telephone or telegram before the time specified in the Notice Inviting Bids for the public opening of bids, this Proposal constitutes an irrevocable offer for 90 calendar days after that date.
2. County has the right to reject any or all Proposals and to waive any irregularities or informalities contained in a Proposal.
3. To execute the Agreement and deliver the Faithful Performance Bond, Payment Bond and Insurance Certificate with endorsements, which comply with the requirements set forth in the Instructions to Bidders and General Conditions, within ten (10) working days of the date of the Notice of Acceptance of Proposal and Intent to Award as issued by the County of Riverside.
4. That the contract shall be awarded upon a resolution or minute order to that effect duly adopted by the governing body of County; and that execution of the Contract Documents shall constitute a written memorial thereof.
5. To submit to County such information as County may require to determine whether a particular Proposal is the lowest responsible bid submitted.
6. That the accompanying certified or cashier's check or Bid Bond is in an amount not less than 10% of the total bid submitted and constitutes a guarantee that if awarded the contract, Contractor

will execute the Agreement and deliver the required bonds within ten (10) days after notice of award. If Contractor fails to execute and deliver said documents, the check or bond is to be charged with the costs of the resultant damages to County, including but not limited to publication costs, the difference in money between the amount bid and the amount in excess of the bid which it costs County to do or cause to be done the work involved, lease and rental costs, additional salaries and overhead, increased interest and costs of funding the project, attorney expense, additional engineering and architectural expense and cost of maintaining or constructing alternate facilities occasioned by the failure to execute and deliver said documents.

7. By signing this proposal the Contractor certifies that the representations made therein are made under penalty of perjury.

MECCA STREETS REVITALIZATION PROJECT - PHASE 3
66th Avenue, Dale Killer Road, and Home Avenue

Project No. X1002 (Design) and C1-0646 (Construction)

PROPOSAL

ITEM No.	ITEM CODE	ITEM	UNIT	ESTIMATED QUANTITY	ITEM PRICE (IN FIGURES)	TOTAL (IN FIGURES)
1	999990	MOBILIZATION	LS	1		
2	066102	DUST ABATEMENT	LS	1		
3	170101	DEVELOP WATER SUPPLY	LS	1		
4	074020	WATER POLLUTION CONTROL	LS	1		
5	120100	TRAFFIC CONTROL SYSTEM	LS	1		
6	160101	CLEARING AND GRUBBING (INCLUDING REMOVAL OF TREES/SHRUBS, R/W GRADING, INSTALLATION OF IRRIGATION SLEEVES, REMOVAL OF ALL PRIVATE PROPERTY IMPROVEMENTS, CONCRETE/AC SIDEWALK, AC BERM, RECONSTRUCTION OF LANDSCAPING/IRRIGATION, ETC.)	LS	1		
7	190101	ROADWAY EXCAVATION	CY	11,000		
8	390130	HOT MIX ASPHALT	TON	3,700		
9	260201	CLASS 2 AGGREGATE BASE	CY	9,800		
10	017304	MINOR CONCRETE (6" CURB AND GUTTER) (CRS 200)	LF	3,900		
11	017309	MINOR CONCRETE (8" TYPE D CURB) (CRS 204)	LF	400		
12	731521	MINOR CONCRETE (SIDEWALK) (CRS 401)	SQFT	20,500		
13	017315	MINOR CONCRETE (CURB RAMP) (CRS 403 - CASE A)	EA	6		
14	017315	MINOR CONCRETE (CURB RAMP) (PER DETAIL)	EA	3		
15	017302	MINOR CONCRETE (CROSS-GUTTER) (CRS 209)	SQFT	4,400		
16	731516	MINOR CONCRETE (DRIVEWAY) (CRS 207)	SQFT	1,050		
17	731516	MINOR CONCRETE (COMMERCIAL DRIVEWAY) (CRS 207A)	SQFT	4,000		
18	731502	MINOR CONCRETE (MISCELLANEOUS CONSTRUCTION) (BUS STOP PAD - 6" THICK)	SQFT	55		
19	731519	MINOR CONCRETE (STAMPED CONCRETE) (DECORATIVE COLORED CONCRETE)	SQFT	2,200		
20	000003	REMOVE EXISTING FENCE/GATE/WALL AND REPLACE WITH TUBULAR STEEL FENCE	LF	110		
21	198200	PAVEMENT REINFORCING FABRIC (GEOGRID 2-LAYERS PER SQYD)	SQYD	13,500		
22	860604	FLASHING BEACON SYSTEM [SOLAR ADVANCE FLASHING BEACONS]	LS	1		
23	833077	PEDESTRIAN BARRICADE (TYPE I PER DETAIL)	LF	60		
24	000003	MODIFY EXISTING ADA RAMP WITH DETECTABLE WARNING SURFACE	EA	2		

PROPOSAL

ITEM No.	ITEM CODE	ITEM	UNIT	ESTIMATED QUANTITY	ITEM PRICE (IN FIGURES)	TOTAL (IN FIGURES)
25	840656	PAINT TRAFFIC STRIPE (2 COAT) (INCLUDING RED CURB)	LF	6,900		
26	840519	THERMOPLASTIC CROSSWALK AND PAVEMENT MARKINGS	SQFT	500		
27	850102	PAVEMENT MARKER (REFLECTIVE)	EA	525		
28	568023	ROADSIDE SIGN - ONE POST	EA	13		
29	152390	RELOCATE ROADSIDE SIGN	EA	6		
30	860401	LIGHTING [RESIDENTIAL STREET LIGHTING SYSTEM]	LS	1		
31	000003	MISCELLANEOUS DIRECTED WORK	FA	1	75,000.00	75,000.00

PROJECT TOTAL: _____ \$ _____
 ITEMS 1-31 "WORDS"

BIDDER DATA:

Name of Bidder _____

Type of Organization _____

Person(s) Authorized to Sign for Bidder _____

Address _____

Phone _____

Contractor's License Type & Number _____

Expiration Date _____

8. DESIGNATION OF SUBCONTRACTORS: Contractor submits the following complete list of each subcontractor who will perform work or labor or render service in or about the construction in an amount in excess of 1/2 of 1% of the total bid.

<u>ITEM</u>	<u>SUBCONTRACTOR</u>	<u>ADDRESS</u>	<u>LICENSE NO.</u>
-------------	----------------------	----------------	--------------------

Percent of work to be performed by sub-contractors: ___%
(Note: 50% of the work required to be performed by general contractor)

IN WITNESS WHEREOF Contractor executed this Proposal as of the date set forth on Page 1 of this proposal.

TITLE _____
"Contractor"

AFFIDAVIT FOR INDIVIDUAL CONTRACTORS

_____ declares as follows:

That he or she is the party making the foregoing proposal or bid; that the bid is not made in the interest of, or on behalf of, any undisclosed person, partnership, company, association, organization, or corporation; that the bid is genuine and not collusive or sham; that the bidder has not directly or indirectly induced or solicited any other bidder to put in a false or sham bid, and has not directly or indirectly colluded, conspired, connived, or agreed with any bidder or anyone else to put in a sham bid, or that anyone shall refrain from bidding; that the bidder has not in any manner, directly or indirectly, sought by agreement, communication, or conference with anyone to fix the bid price of the bidder or any other bidder, or to fix any overhead, profit, or cost element of the bid price, or of that of any other bidder, or to secure any advantage against the County of Riverside or anyone interested in the proposed contract; that all statements contained in the bid are true; and, further, that the bidder has not, directly or indirectly, submitted his or her bid price or any breakdown thereof, or the contents thereof, or divulged information or data relative thereto, or paid, and will not pay, any fee to any corporation, partnership, company association, organization, bid depository, or to any member or agent thereof to effectuate a collusive or sham bid.

I declare, under penalty of perjury, that the foregoing is true and correct.

Dated this _____ (day) of _____ (month),
_____ (year) at _____, California

Signature of affiant: _____

Note: Notarization of signature required

AFFIDAVIT FOR JOINT VENTURE OR COPARTNERSHIP CONTRACTOR

_____ Declares as follows:

That he or she is a member of the joint venture or copartnership firm _____ designated _____ as which is the party making the foregoing proposal or bid; that the bid is not made in the interest of, or on behalf of, any undisclosed person, partnership, company, association, organization, or corporation; that the bid is genuine and not collusive or sham; that the bidder has not directly or indirectly induced or solicited any other bidder to put in a false or sham bid, and has not directly or indirectly colluded, conspired, connived, or agreed with any bidder or anyone else to put in a sham bid, or that anyone shall refrain from bidding; that the bidder has not in any manner, directly or indirectly, sought by agreement, communication, or conference with anyone to fix the bid price of the bidder or any other bidder, or to fix any overhead, profit, or cost element of the bid price, or of that of any other bidder, or to secure any advantage against the County of Riverside or anyone interested in the proposed contract; that all statements contained in the bid are true; and, further, that the bidder has not, directly or indirectly, submitted his or her bid price or any breakdown thereof, or the contents thereof, or divulged information or data relative thereto, or paid, and will not pay, any fee to any corporation, partnership, company association, organization, bid depository or to any member or agent thereof to effectuate a collusive or sham bid.

That he has been and is duly vested with authority to make and sign instruments for the joint venture or copartnership by _____ who constitute the other members of the joint venture or copartnership.

I declare, under penalty of perjury, that the foregoing is true and correct.

Dated this _____ (day) of _____ (month),
_____ (year) at _____, California

Signature of affiant: _____

Note: Notarization of signature required

AFFIDAVIT FOR CORPORATE CONTRACTOR

_____ declares as follows:

That he or she is _____ of

_____ a corporation which is the party making the foregoing proposal or bid; that the bid is not made in the interest of, or on behalf of, any undisclosed person, partnership, company, association, organization, or corporation; that the bid is genuine and not collusive or sham; that the bidder has not directly or indirectly induced or solicited any other bidder to put in a false or sham bid, and has not directly or indirectly colluded, conspired, connived, or agreed with any bidder or anyone else to put in a sham bid, or that anyone shall refrain from bidding; that the bidder has not in any manner, directly or indirectly, sought by agreement, communication, or conference with anyone to fix the bid price of the bidder or any other bidder, or to fix any overhead, profit, or cost element of the bid price, or of that of any other bidder, or to secure any advantage against the County of Riverside or anyone interested in the proposed contract; that all statements contained in the bid are true; and, further, that the bidder has not, directly or indirectly, submitted his or her bid price or any breakdown thereof, or the contents thereof, or divulged information or data relative thereto, or paid, and will not pay, any fee to any corporation, partnership, company association, organization, bid depository, or to any member or agent thereof to effectuate a collusive or sham bid.

I declare, under penalty of perjury, that the foregoing is true and correct.

Dated this _____ (day) of _____ (month),
_____ (year) at _____, California

Signature of affiant: _____

Note: Notarization of signature required

AGREEMENT

THIS AGREEMENT is entered into at Riverside, California as of the date set forth below is between County of Riverside hereafter called "County" and _____ hereafter called "Contractor".

W I T N E S S E T H

RECITALS:

1. Contractor has submitted to County his Contractor's Proposal for the construction of County Project, _____ in strict accordance with the Contract Documents identified below and County has accepted said Proposal.
2. Contractor states that he has reexamined his Contractor's Proposal and found it to be correct, has ascertained that his subcontractors are properly licensed and possess the requisite skill and forces, has reexamined the site and Contract Documents and is of the opinion that he can presently do the work in accordance with the Contract Documents for the money set forth in his Proposal to be paid as provided in the Contract Documents.

AGREEMENT:

IT IS AGREED BY THE PARTIES AS FOLLOWS:

1. Contract Documents. The entire contract consists of the following: (a) The Agreement. (b) The Notice Inviting Bids. (c) The Instruction to Bidders. (d) The Contractor's Proposal. (e) The Bid Bond. (f) The Payment Bond. (g) The Performance Bond. (h) The General Conditions. (i) The Special Provisions. (j) The Standard Specifications of the State of California Department of Transportation edition of May 2006 as modified in other portions of the Contract Documents. (k) The Standard Plans of the Department of Transportation identified on the plans or in the Special Provisions. (l) The Plans. (m) Addenda No. _____. (n) The Determination of Prevailing Wage Rates for Public Work. (o) Any Change Orders issued. (p) Any additional or supplemental specifications, notice, instructions and drawings issued in accordance with the provisions of the Contract Documents. All of said Documents presently in existence are by this reference incorporated herein with like effect as if here set forth in full and upon the proper issuance of other documents they shall likewise be deemed incorporated. The Bid Bond is exonerated upon execution of this Agreement and the Payment Bond and Faithful Performance Bond.
2. The Work. Contractor shall do all things necessary to construct the work generally described in Recital No. 1 in accordance with the Contract Documents.

3. Liquidated Damages and Time of Completion. Attention is directed to the provisions in Section 8-1.06, "Time of Completion", and in Section 8-1.07, "Liquidated Damages", of the Standard Specifications and these Special Provisions.

The Contractor shall begin work within 15 days of the date stated within the written "Notice to Proceed".

The Contractor shall notify the Engineer, in writing, of his intent to begin work at least 72 hours before work is begun. The notice shall be delivered to the Transportation Department's Construction Engineer and shall specify the date the Contractor intends to start. If the project has more than one location of work, a separate notice shall be given for each location.

Should the Contractor begin work in advance of receiving a written "Notice to Proceed", any work performed by him in advance of the date stated in the "Notice to Proceed" shall be considered as having been done by him at his own risk and as a volunteer and subject to the following:

- (1) The Contractor shall, on commencing operations, take all precautions required for public safety and shall observe all the provisions in the Specifications and the Special Provisions.
- (2) All work done according to the contract prior to the issuance of the "Notice to Proceed", will be considered authorized work and will be paid for as provided in the contract.
- (3) The Contractor shall not be entitled to any additional compensation or an extension of time for any delay, hindrance or interference caused by or attributable to commencement of work prior to the issuance of the "Notice to Proceed".

4. Compensation. Contractor shall be paid in the manner set forth in the Contract Documents the amount of his Proposal as accepted by County, the above rates, subject to additions and deductions as provided in the Contract Documents. Said Proposal is on file in the Office of the Clerk of the Board of Supervisors of County.

IN WITNESS WHEREOF the parties hereto have executed this agreement as of the date set forth below.

COUNTY OF RIVERSIDE

CONTRACTOR

BY _____
Chairman, Board of Supervisors

BY _____

Dated _____

TITLE: _____
(If Corporation, Affix Seal)

ATTEST:

Kecia Harper-Ihem, Clerk of the Board

ATTEST:

BY _____
Deputy

TITLE: _____

Licensed in accordance with an act providing for the registration of Contractors,

License No. _____

Federal Employer Identification Number:

"County"
(Seal)

"Corporation"
(Seal)

PERFORMANCE BOND

Recitals:

1. _____ (Contractor) intend to enter into an Agreement with COUNTY OF RIVERSIDE (County) for construction of public work known as _____.
2. _____, a _____ corporation (Surety), is the Surety under this Bond.

Agreement:

We, Contractor, as Principal, and Surety, as Surety, jointly and severally agree, state, and are bound unto County, as obligee, as follows:

1. The amount of the obligation of this Bond is 100% of the estimated contract price for the Project of \$_____ and inures to the benefit of County.
2. This Bond is exonerated by Contractor doing all things to be kept and performed by it in strict conformance with the Contract Documents for the Project, otherwise it remains in full force and effect for the recovery of loss, damage and expense of County resulting from failure of Contractor to so act. All of said Contract Documents are incorporated herein.
3. This obligation is binding on our successors and assigns.
4. For value received, Surety stipulates and agrees that no change, time extension, prepayment to Contractor, alteration or addition to the terms and requirements of the Contract Documents or the work to be performed thereunder shall affect its obligations hereunder and waives notice as to such matters, except the total contract price cannot be increased by more than 10% without approval of Surety.

THIS BOND is executed as of _____.

By _____

By _____

By _____

Type Name _____

Its Attorney in Fact
"Surety"

Title _____

"Contractor"

(Corporate Seal)

(Corporate Seal)

NOTE: This Bond must be executed by both parties with corporate seal affixed. All signatures must be acknowledged. (Attach acknowledgements).

PAYMENT BOND

(Public Work - Civil Code 3247 et seq.)

The makers of this Bond are _____, as Principal and Original Contractor and _____, a corporation, authorized to issue Surety Bonds in California, as Surety, and this Bond is issued in conjunction with that certain public works contract to be executed between Principal and COUNTY OF RIVERSIDE a public entity, as Owner, for \$ _____, the total amount payable. THE AMOUNT OF THIS BOND IS ONE HUNDRED PERCENT OF SAID SUM. Said contract is for public work generally consisting of _____.

The beneficiaries of this Bond are as is stated in 3248 of the Civil Code and requirements and conditions of this Bond are as is set forth in 3248, 3249, 3250 and 3252 of said code. Without notice, Surety consents to extension of time for performance, change in requirements, amount of compensation, or prepayment under said contract.

DATED: _____

Original Contractor - Principal

Surety

By _____

By _____
Its Attorney In Fact

Title _____
(If corporation, affix seal)

(Corporate Seal)

STATE OF CALIFORNIA }
COUNTY OF _____ } ss. SURETY'S ACKNOWLEDGEMENT

On _____ before me, _____ personally appeared, _____, known to me, or proved to me on the basis of satisfactory evidence, to be the person whose name is subscribed to the within instrument and acknowledged to me that he/she executed the same in his/her authorized capacities, and that by his/her signature on the instrument the person, or the entity upon behalf of which the person acted, executed the instrument.

WITNESS my hand and official seal.

Signature of Notary Public

Notary Public (Seal)

Note: This Bond must be executed by both parties with corporate seal affixed. All signatures must be notarized

GENERAL CONDITIONS

SS 1. DEFINITIONS:

- a. "County", "Contractor", and "Contract Documents" are identified in the Agreement. "County" and "Contractor" includes their authorized representatives are treated throughout as if each were singular in number. "Contractor" includes its surety.
- b. "Engineer" and "Director of Transportation" means the Director of Transportation for the County of Riverside, and includes his authorized representatives.
- c. "Plans" means the portion of the Contract Documents consisting of all drawings prepared for the direction and characteristics of the work. A schedule of said drawings which constitutes the plans as of the execution of the Agreement is set forth in the Special Provisions and are supplemented by the Standard Plans referred to in the Special Provisions.
- d. "State of California", "Department of Transportation" and "Director of Transportation", means the County of Riverside.

SS 2. STANDARD SPECIFICATIONS:

The Standard Specifications of the State of California Department of Transportation, edition of May 2006 hereafter called "Standard Specifications", are incorporated herein as modified in these General Conditions, the Special Provisions and the Plans.

The following subsections of the Standard Specifications are deleted:

1-1.13, 1-1.15, 1-1.18, 1-1.25, 1-1.37, 1-1.40, 2-1.01, 2-1.05, 2-1.07, 5-1.14, 7-1.165, 8-1.03, 9-1.05, 9-1.065, 9-1.10, 12-2.02.

Section 3 of the Standard Specifications is deleted.

The following deletions and additions are made from the following subsections of the Standard Specifications.

Subsection 5-1.04, add to the second paragraph at its end the following sentence: "The General Conditions govern over all of the Contract Documents except the Special Provisions, the Agreement and Bonds."

Subsection 7-1.01A (2), strike the last sentence of the second paragraph and in its place read: "These wage rates are on file in the Office of the County Clerk and are a part of the Contract."

Subsection 7-1.15, for "Director" read "Director of Transportation" except for last reference read "County of Riverside".

Subsection 7-1.16, delete references to Subsection 7-1.165.

Subsection 8-1.06, strike the last paragraph.

Subsection 8-1.08, strike "as provided in the State Contract Act".

SS 3. DIRECTOR OF TRANSPORTATION:

All work shall be done under the supervision of the Director of Transportation who shall determine the amount, quality, acceptability and fitness of all parts of the work, and interpret the Contract Documents. No act or omission of the Director of Transportation relieves Contractor of the duty to proceed with the work in strict conformity with the Contract Documents.

Upon request, Director of Transportation shall reduce to writing any oral order, objection, requirement or determination. Whenever Director of Transportation's approval is required it shall be in writing only.

All communications to County by Contractor shall be via Director of Transportation.

No work shall be performed on site other than during normal working hours without the knowledge and consent of Director of Transportation.

When in Director of Transportation's opinion, weather or other conditions are such that attempts to perform a portion of the work will probably result in work not in accordance with the Contract Documents, he shall so advise Contractor. When Contractor advises Director of Transportation that he intends to proceed despite such advise, he does so at his peril. The Director of Transportation may then order Contractor, in writing which specifies the portion of the work involved and the conditions warranting the issuance of the order, not to proceed on such portion of the work if (1) proceeding will in his judgment have an adverse effect on Contractor's ability to complete the work within the stipulated time period, or (2) proceeding will in his judgment necessitate unusual tests and procedures to ascertain whether said portion of the work is in accordance

with the Contract Documents. Contractor shall comply with such orders at its expense.

Nothing herein contained relieves Contractor from the duty to make independent determinations as to weather and other conditions affecting the proper completion of the work.

Failure for any reason of Director of Transportation to advise Contractor as to such matters, or to issue an order as above provided, does not relieve Contractor from the duty to accomplish the work in accordance with the Contract Documents.

As stated elsewhere, amounts shown in the Proposal and Agreement as to quantities are but estimates only. From time to time Director of Transportation shall direct Contractor as to the prosecution of the work in such a manner as to increase or decrease such estimates as to the work actually to be done. Contractor shall comply with such instructions and shall be paid only for work actually done based on the unit price set out in the Agreement.

SS 4. SITE INSPECTION - EFFECT OF OTHER IMPROVEMENTS SHOWN AND CONTRACTOR PROCEDURE:

Elsewhere in the Contract Documents reference may be made, graphically, descriptively or both, to the existence or possible existence of other improvements affecting the site and the prosecution of the work such as surface and subsurface utilities, drainage ditches and courses, buildings, fencing, retaining walls, roadways, curbs, trees, shrubs, and similar matters. Such matters are included to be used by Contractor to the extent he deems appropriate. However, it is expressly understood and agreed:

- a. Showing or describing such items does not mean that it is an exhaustive and complete presentation and that as to matters shown or described that they necessarily exist.
- b. All graphic presentations are schematic only unless the contrary is clearly set out elsewhere as to a particular matter.
- c. Whenever in the plans survey markers are shown, boundaries of the site are shown or contour lines are shown, Contractor may assume that such matters are shown in accordance with acceptable standards.

All improvements of the nature above described, whether elsewhere shown or described or not, shall, unless the contrary is elsewhere specifically directed, remain in

place, undisturbed and suitably protected during the course of the work.

Whenever during the course of the work a subsurface improvement is discovered which Contractor believes is unknown to County, he shall immediately so inform Director of Transportation. Except as elsewhere provided, whenever in the course of the work it becomes apparent that the work cannot proceed without the destruction or relocation of any improvement, whether shown or described or not, Contractor shall immediately cease work affecting such improvements and notify Director of Transportation as to such circumstance and await instructions as to how to proceed.

- d. The Contractor shall be required to cooperate fully with all utility forces or forces of other public agencies engaged in relocation, lowering, altering or otherwise rearranging any facilities interfering with the progress of work or installing any facilities thereon.

The Contractor will also be required to cooperate fully with any County or State forces working on or near the project, or requiring access to the work in the performance of their duties.

SS 5. USE OF AND PROTECTION OF PREMISES AND REMOVAL OF DEBRIS:

At his expense Contractor shall:

- a. Take every precaution against injuries to persons or damage to property.
- b. Comply with regulations governing the use of the property.
- c. Store and suitably protect his apparatus, equipment, materials and supplies in an orderly fashion on site.
- d. Place on the work only such loads as are consistent with the safety of the work.
- e. Effect all cutting, fitting, or patching of his work required to make it conform to the Plans and Specifications and interrelate with other improvements or except with the consent of Director of Transportation, cut or otherwise alter existing improvements.
- f. Protect and preserve established bench marks and monuments, make no changes in the location of such without the prior written approval of County, replace and relocate any of them which may be lost or destroyed

or which require shifting because of necessary changes in grades or locations. All replacement and relocation work shall be accomplished only after approval of County and under the direct supervision and instruction of Director of Transportation.

- g. Before final payment remove all surplus materials, false work, temporary structures, debris, and similar matter resulting from his operations from the site and to put the site in an orderly condition.
- h. Construct, operate and maintain all passageways, guard fences, lights, barricades and other facilities required for protection by State or municipal laws and regulations and local conditions during the course of the work.
- i. Guard County's property from injury or loss.
- j. Take all reasonable precautions for dust and noise control and generally conduct operations so as not to constitute a nuisance.
- k. The Contractor shall be responsible for the protection of existing signs, fences, concrete curb and gutter and other highway facilities which may be encountered in the roadway. The replacement or repair of any facilities which the County deems necessary as a result of the Contractor's operations shall be done by the Contractor at his own expense and to the satisfaction of the County Transportation Department.

SS 6. CHANGE ORDERS - DETAIL DRAWINGS AND INSTRUCTIONS:

Reference is made to 4-1.03 and 4-1.03A of the Standard Specifications regarding change orders. Wherever in these subsections the word "Engineer" appears read "County".

Each approved change order shall be considered as an amendment to the Contract Documents and will not be considered approved until executed by the Board of Supervisors, except Director of Transportation can approve certain change orders without the necessity of approval by the Board as provided in a Resolution of the Board adopted March 30, 1993, Resolution Number 93-047.

The above does not limit the ability of Director of Transportation to issue further detail drawings, explanations and instructions which are customarily given by an Engineer during the course of similar work. Director of Transportation will furnish Contractor with reasonable promptness such further detailed explanations, instructions and drawings as may be necessary for the proper execution of the work, and

Contractor shall conform to same provided they are consistent with the intent of the Contract Documents. In giving such additional instructions, explanations and drawings Director of Transportation has authority to make minor changes in the work which do not involve extra cost and are not inconsistent with the Contract Documents.

Contractor's acting on such instructions, explanations and drawings of Director of Transportation means that Contractor agrees that such explanations, instructions and drawings are within the scope of the work in accordance with the intent of the Contract Documents and do not constitute a basis for modification of the Contract Documents as to price or time.

SS 7. BRAND OR TRADE NAME - SUBSTITUTE OF EQUALS:

Reference is made to Section 3400 of the Public Contracts Code, which is by this reference incorporated herein with like effect as if here set forth in full.

If a potential bidder believes he knows of an equal to a specified brand or trade name which is not mentioned in the Contract Documents, then such potential bidder may so advise Director of Transportation of such fact, giving all relevant information. If appropriate, an addendum will be issued as to the alleged equal provided that such issuance may be accomplished at least 5 days before the time fixed for opening bids.

Unless the subject article or product is expressly designated for matching others in use in a particular public improvement either completed or in the course of completion, any bidder may, as part of its bid proposal, include a request for substitution of an item equal to any specified by brand or trade name.

Within 35 calendar days after award of the contract, Contractor may submit to Director of Transportation data substantiating such a request, and the difference, if any, in cost. Director of Transportation shall promptly investigate the request and make a recommendation to County as to equality. The governing body of County shall promptly determine whether the substitute is equal in every respect to the item specified, and approve or deny the request accordingly, and shall notify Director of Transportation of the determination made, who shall advise Contractor in writing of the decision. Unless the request is granted, substitution will not be permitted.

Nothing herein shall authorize a change in the contract price or prevent the use of change orders in the manner provided elsewhere in the Contract Documents.

SS 8. FINAL INSPECTION - NOTICE OF COMPLETION:

When the work is ready for final inspection County shall cause the work to be inspected and subjected to such tests as seem to it to be required for the purpose of determining if the work is complete in every respect.

At a meeting of the governing body of County held within 10 days after final inspection, the governing body shall consider the facts developed at the inspection. If it is found that the work is apparently complete in every respect, County will accept the work and a notice of completion will be recorded.

As between the parties, the recordation of the Notice of Completion, unless recorded because of a cessation of labor, means only that the time for final payment and the commencement of the guarantee period commences to run.

SS 9. COUNTY'S RIGHT TO STOP WORK OR TERMINATE THE CONTRACT:

(1) Contractor shall be adjudged bankrupt or make an assignment for the benefit of creditors, or (2) a receiver or liquidator is appointed for Contractor or any of his property, or (3) Contractor shall refuse or fail after Notice of Warning from County by Director of Transportation to supply sufficient properly skilled workmen or suitable materials, or (4) Contractor fails to prosecute the work with such diligence as will insure its completion within the stipulated time period, or (5) Contractor shall fail to make payments to persons supplying labor or materials for the work, or (6) Contractor does not comply with applicable law or instructions of Director of Transportation, or (7) Contractor is otherwise guilty of a substantial violation of any provision of the Contract Documents, then County without prejudice to such other and further right, remedy or relief it may be entitled to, may by 10 days notice to Contractor, terminate the employment of Contractor and his right to proceed, either as to the entire work, or at County's option, as to any portion thereof as to which delay shall have occurred or breach or miscompliance relates, and may thereupon take possession of the affected work and complete the work by contract or otherwise, as County deems expedient. In such case Contractor shall not be entitled to receive any further payment until the work is finished. If the unpaid balance shall exceed the expense of completion, and other damage, expense or loss of County occasioned by Contractor's failure to properly perform, such excess shall be paid by Contractor. If such expense and damage exceeds the unpaid balance, Contractor is liable to County for the excess. If County elects to proceed under this Section, it may take possession of and utilize in completing the work such materials, supplies, plant and equipment on site which may be

necessary or convenient for the purpose of completing the work, County is expressly granted the right - acting via Director of Transportation, an Engineer or otherwise - to operate equipment and machinery on site for the purpose of determining whether it has a basis for proceeding under this section.

If the construction of the project herein is damaged, which damage is determined to have been proximately caused by an act of God, in excess of 5% of the contract amount, provided that the work damaged is built in accordance with applicable building standards and the plans and specifications, then the Owner, upon certification by the Engineer, may, without prejudice to any other right of remedy, terminate the contract.

Decision by County not to proceed under this Section does not constitute a waiver by County of any right it might from time to time have against Contractor under the Contract Documents.

SS 10. PAYMENT AND MONTHLY ESTIMATES:

Director of Transportation, once each month, after said work is commenced and until after the completion and acceptance thereof, shall make and deliver to Contractor duplicate certificates stating the value of work then completed according to the contract, estimated according to the standard of the unit contract price, and thereupon Contractor shall be paid an amount sufficient with all previous payments to make the aggregate ninety percent (90%) of the amount earned as certified.

The partial payments made as the work progresses will be payment on account on work performed as of the 25th of the month and shall in no way be considered as an acceptance of any part of the work or material of the contract, nor shall they in any way govern the final estimate. No such estimate or payment shall be made when in the judgement of the Director of Transportation the total value of the work done since the last estimate amounts to less than \$300.

For the purpose of timely payment, the "receipt of payment request" date, as described in Public Contract Code 20104.50 and as referred to herein, shall be considered to be the fifth working day following the 25th day of each month. Within 5 working days of the 25th day of each month the County shall:

- a. Calculate and prepare the certificate ("progress pay estimate") stating the value of the work completed for the billing month, for the purpose of determining the proper progress payment amount.

- b. If a progress pay estimate has been prepared by the County but has been contested by the Contractor as of the "receipt of payment request" date, as defined above, the County shall submit to the Contractor a document setting forth in writing a description of the dispute pertaining to the progress billing, and the County's reason for its position. Said document shall be submitted to the Contractor as soon as practicable, but not later than 7 calendar days after the "receipt of payment request" date.

Any progress pay estimate which is undisputed and remains unpaid for thirty (30) calendar days, after the "receipt of payment request date" shall accrue interest to the Contractor equivalent to the legal rate set forth in subdivision (a) of Section 685.010 of the California Code of Civil Procedure. The number of days available to the County to make a payment without incurring interest pursuant to this section shall be reduced by the number of days by which the County exceeds the seven-day submittal requirement set forth in the paragraph above.

Pursuant to Public Contract Code Section 20104.50, subsection (e), the progress payment date is the date that funds are encumbered and the payment warrant is issued.

SS 11. PAYMENT FOR EXTRA WORK (FORCE ACCOUNT BASIS):

Extra work to be paid for on a force account basis as directed by the Engineer will be paid for as set forth in Section 9-1.03 of the Standard Specifications. The labor surcharge, equipment rental rates and the right of way delay factors for each classification of equipment are listed in the Department of Transportation publication entitled Labor Surcharge and Equipment Rental Rates. A copy of which is on file at the Office of the Director of Transportation and is hereby incorporated herein in its entirety.

SS 12. FINAL PAYMENT:

Within thirty (30) days after the completion of the work and its acceptance by the Board of Supervisors, Director of Transportation will make a proposed final estimate in writing of the quantities of work done under the contract and the value of such work and will submit such estimate to Contractor. Within thirty (30) days thereafter Contractor shall submit to Director of Transportation his written approval of said proposed final estimate or a written statement of all claims which he has for additional compensation claimed to be due under the contract.

On Contractor's approval or if he files no claims within said period of thirty (30) days, Director of Transportation will issue a final written estimate as submitted to Contractor and County shall pay the entire sum so found to be due after deducting there from all previous payments and all amounts to be kept and all amounts to be retained under the provisions of the contract.

If Contractor within said period of thirty (30) days files claims, Director of Transportation will issue as a semi-final estimate the proposed estimate submitted to Contractor and the County will within thirty (30) days pay the sum found due thereon after deducting all prior payments and all amounts to be kept and retained under the provisions of the contract, Director of Transportation shall then consider and investigate Contractor's claims and shall make such revisions in the said estimate as he may find to be due, and shall then make and issue his final written estimate. County will pay the amount so found due after deducting all previous payments and amount to be retained under the contract.

All prior or partial estimates and payments shall be subjected to correction in the final estimate and payment.

The final estimate shall be conclusive and binding against both parties to the contract on all questions relating to the performance of the contract and the amount of work done there under and compensation therefore, except in the case of gross error. Acceptance of final payment constitutes a release of County by Contractor of all claims relating to the work.

SS 13. DAMAGES:

Contractor acknowledges that failure to perform in strict accordance with the Contract Documents will cause County to suffer special damages in addition to cost of completion of the work in accordance with the provisions of the Contract Documents. Such special damage could include, but is not limited to, lease and rental cost, additional salaries and overhead, interest during construction, attorney expense, additional engineering, and inspection expense and cost of maintaining or constructing alternate facilities.

SS 14. DOCUMENTS OF CONTRACTOR:

Upon demand, Contractor shall make available to County all documents in its possession relevant to the work accomplished or to be accomplished or any demand or claim of Contractor as to County. This includes copies of documents sent by Contractor or others in its possession. Contractor shall further make available to County conformed copies of all documents submitted to the sureties who executed the Bid

Bond, Faithful Performance Bond or Payment Bond for the purpose of obtaining the sureties' signature, including any guarantee or indemnification made to such surety by others for such purpose. Contractor shall maintain in his possession all documents relative to the work for three years after Notice of Completion.

SS 15. RESPONSIBILITY OF CONTRACTOR TO ACT IN AN EMERGENCY:

In case of an emergency which threatens loss or injury to property or life, Contractor shall act without previous instructions as the situation may warrant. Contractor shall notify Director of Transportation immediately thereafter. Any compensation claimed by Contractor, together with substantiating documentation shall be submitted to County via Director of Transportation.

SS 16. LABOR CODE:

Reference is made to Chapter 1, Part 7, Division 2 of the California Labor Code (commencing with Section 1720). By this reference said Chapter 1 is incorporated herein with like effect as if it were here set forth in full. The parties recognize that said Chapter 1 deals, among other things with discrimination, penalties and forfeitures, their disposition and enforcement, wages, working hours, and securing worker's compensation insurance and directly effect the method of prosecution of the work by Contractor and subject it under certain conditions to penalties and forfeitures. Execution of the Agreement by the parties constitutes their agreement to abide by said Chapter 1, their stipulation as to all matters which they are required to stipulate as to by the provisions of said Chapter 1, constitutes Contractor's certification that he is aware of the provisions of said Chapter 1 and will comply with them and further constitutes Contractor's certification as follows: "I am aware of the provisions of Section 3700 of the California Labor Code which require every employer to be insured against liability for worker's compensation or to undertake self-insurance in accordance with the provisions of that Code, and I will comply with such provisions before commencing the performance of the work of this contract." Contractor and his subcontractors shall comply with the provisions of SS 1777.5 of the Labor Code regarding apprentices.

Contractor shall post at each job site during the course of the work a copy of County's "Determination of Prevailing Wage Rates", copies of said Determination are available from County for this purpose.

SS 17. OBSTRUCTIONS:

Attention is directed to Sections 8-1.10, "Utility and Non-Highway Facilities" and 15, "Existing Highway Facilities" of the Standard Specifications and these Special Provisions.

Add the following to the fourth paragraph of Section 8-1.10, "Utility and Non-Highway Facilities", of the Standard Specifications is amended to read:

In the event that the utility facilities mentioned above are not removed or relocated by the times specified and, if in the opinion of the Engineer, the Contractor's operations are delayed or interfered with by reason of the utility facilities not being removed or relocated by said times, the State will compensate the Contractor for such delays to the extent provided in Section 8-1.09, "Right of Way Delays" of the Standard Specifications, and not otherwise, except as provided in Section 8-1.10, "Utility and Non-Highway Facilities" of the Standard Specifications.

SS 18. INSURANCE - HOLD HARMLESS:

In lieu of the provisions of Section 7-1.12 the following shall apply:

Contractor shall not commence work under this contract until he has obtained the insurance required hereunder and satisfactory proof of said insurance has been submitted to and approved by the County of Riverside.

Contractor shall submit to the County of Riverside a Certificate of Insurance, signed by an authorized representative of the Contractor's insurance provider or agency, which certifies to the County that insurance coverage is provided in accordance with the requirements of this section. The Certificate of Insurance shall include as attachments the required "Waiver of Subrogation" and "Additional Insured" policy endorsements.

I. Workers Compensation Insurance:

Contractor shall procure and maintain during the life of the contract Worker's Compensation Insurance coverage as prescribed by the laws of the State of California. Policy shall include Employers' Liability including Occupational Disease with limits not less than \$1,000,000 per occurrence. Policy shall be endorsed to provide a Borrowed Servant Endorsement, Alternate Employer Endorsement, or Additional Insured Endorsement naming the County of Riverside, its Director's Officers,

Special Districts, Board of Supervisors, employees, agents or representatives as Additional Insureds. Policy shall contain a Waiver of Subrogation in favor of the County of Riverside.

Contractor shall further require each of its subcontractors to procure Worker's Compensation Insurance as required by the State while working on the project and the Contractor shall require the subcontractors to endorse the policy to provide a Borrowed Servant Endorsement, Alternate Employer Endorsement, or Additional Insured Endorsement naming the County of Riverside, its Director's Officers, Special Districts, Board of Supervisors, employees, agents or representatives as Additional Insureds. Policy shall contain a Wavier of Subrogation in favor of the County of Riverside.

II. Comprehensive General Liability Insurance:

Contractor shall take out and maintain during the course of the work General Liability Insurance covering bodily injury and property damage insurance and blanket contractual coverage as to the work and obligations covered hereunder. The amount of the insurance shall be in an amount **not less than \$2,000,000**. The policy may be a combined single limit or split limits, but the amount must be no less than \$2,000,000 per occurrence. The insurance carrier must have a current rating of "A" or better by the A.M. Best Company, a financial size of at least "VIII", and be an admitted carrier in the State of California. Any exceptions must be approved in advance by the County of Riverside Risk Management. Said insurance must contain an endorsement the County of Riverside is named as an additional insured as respects the work covered hereunder and said insurance must not contain, as respects the work covered hereunder, any exclusions as to bodily injury or death or property damage arising out of blasting, explosion, or underground damage to wire, pipes, conduits, mains, sewers, tank tunnels or any similar property - i.e. the so-called "x c u" exclusions. The insurance certificate evidencing such insurance must affirmatively state that the insurance carrier (s) will give Owner 30 days written notice prior to cancellation of the insurance or a reduction in coverage, and that "County of Riverside--its Director's Officers, Special Districts, Board of Supervisors, employees, agents and representatives" are named as Additional Insureds.

In the alternate to naming County of Riverside as additional insured, Contractor may take out and maintain during the course of the work and until acceptance by County, Owner's Protective Liability Insurance in an

amount not less-than \$2,000,000 covering Riverside County.

III. Auto Liability:

If Lessee's vehicles or licensed mobile equipment will be on the premises or used in any manner on behalf of the County, then Lessee shall maintain auto liability insurance for all owned, non-owned or hired automobiles in an amount not less than \$1,000,000 per occurrence combined single limit. Policy shall name the "County of Riverside, its Director's Officers, Special Districts, Board of Supervisors, employees, agents, or representatives" as Additional Insureds.

IV. Hold Harmless:

Contractor shall hold County of Riverside its officers, agent, and employees free and harmless from any liability whatsoever, including wrongful death, based or asserted upon any act or omission of Contractor, its officers, agents, employees or subcontractors relating to or in anywise connected with or arising from the accomplishment of the work, whether or not such acts or omissions were in furtherance of the work required by the Contract Documents and agrees to defend at his expense, including attorney fees, Owner, County of Riverside its officers, agents and employees in any legal action based upon any such alleged acts or omissions.

SS 19. EQUAL EMPLOYMENT OPPORTUNITY:

General:

Contractor shall not discriminate in its recruiting, hiring, promotion, demotion or termination practices on the basis of race, religious creed, color, national origin, ancestry, sex, age or physical handicap in the performance of this Contract shall comply with the provisions of the California Fair Employment Practice Act (commencing with SS 1410 of the Labor Code), the Federal Civil Rights Act of 1964 (P.L. 88-352) and all amendments thereto, Executive Order No. 11246 (30 Federal Register 12319), as amended, and all administrative rules and regulations issued pursuant to said Acts and Order. See particularly 41 Code of Federal Regulation (CFR) Chapter 60.

Contractor shall require each of its subcontractors to comply with the preceding paragraph and shall include in each subcontract language similar to the preceding paragraph.

Contractor shall permit access to its records of employment, employment advertisement, application forms and other pertinent data and records by Owner and any State or Federal agency having jurisdiction for the purpose of investigation to ascertain compliance with this Section.

Owner may assign an affirmative action representative to monitor Contractor and its subcontractor (s) conduct required by this Section, including the right of entry to the construction site for the purpose of obtaining information from persons performing work on the project providing such inspection does not interfere with the progress of the work.

Elsewhere in the Contract Documents specific requirements may be contained covering the same subject matter of this Section. If so, such specific requirements prevail over this Section in case of conflict.

Transactions of \$10,000 or Under:

Contracts and subcontracts not exceeding \$10,000 are exempt from the requirements of this Section. No Contractor or subcontractor shall procure supplies and/or services in less than usual quantities to avoid applicability of this Section. With respect to contracts and subcontractors for indefinite quantities, this Section applies unless the amount required in any one year under such contract will reasonably be expected not to exceed \$10,000.

Transactions in Excess of \$10,000, but Less Than \$50,000:

At Owner's request, Contractor shall certify that it has in effect an affirmative action plan and agrees to comply with all State and Federal laws and regulations regarding Fair Employment Practices. Contractor shall maintain a written copy of its affirmative action plan and furnish Owner a copy of the plan upon request. Owner may require Contractor to complete an Affirmative Action Compliance Report, on a form furnished by Owner, setting forth definite goals during the term of the Contract.

Transactions of \$50,000 or More:

If Contractor has fifty or more employees and a Contract for \$50,000 or more, it shall develop and submit to Owner, within thirty days after award, a written affirmative action compliance program providing in detail specific steps to guarantee equal employment opportunity. Contractor shall include in its affirmative action program a table of job classifications, which table shall include but need not be limited to job titles, duties, and rates of pay.

Contractor shall in each subcontract let to do a portion of the work covered hereunder, where the subcontractor involved has fifty or more employees and the subcontract is for \$50,000 or more, impose in the subcontract the above requirements.

For the purpose of determining the number of employees, the average of the Contractor's or its subcontractor's employees for the twelve month period immediately prior to award, or the total number of employees the Contractor or its subcontractor will have when performing this contract, whichever is higher, shall be used.

Federal Assisted Construction:

If this project is a Federally assisted construction project, then the contract provisions contained in 41 CFR SS 60-1.04 (b) are incorporated herein and the Contractor shall likewise incorporate said provisions in each subcontract entered by Contractor to perform the work. Federally assisted construction is identified as such in the Notice Inviting Bids.

SS 20. DEPOSIT OF SECURITIES:

In accordance with Public Contract Code Section 22300 and other applicable law, the Contractor may substitute securities for any moneys withheld to ensure performance under the contract.

SS 21. ASSIGNMENT OF CLAIMS:

In submitting a bid on this public works project, or any subcontractor agreeing to supply goods, services, or materials, and entering a contract pursuant thereto, the Contractor and/or subcontractor do offer and agree to assign to the Owner all rights, title, and interest in and to all causes of action it may have under Section 4 of the Clayton Act (15 U.S.C. Section 15) or under the Cartwright Act (Chapter 2 (commencing with Section 16700) of Part 2 of Division 7 of the Business and Professions Code), arising from purchases of goods, services, or materials pursuant to the public works contract or the subcontract. This assignment shall be made and become effective at the time the awarding body tenders final payment to the Contractor, without further acknowledgement by the parties.

SS 22. CLAIMS RESOLUTION:

In accordance with Public Contract Code Section 20104 - 20104.8 and other applicable law, public works claims of \$375,000 or less which arise between the Contractor and the Owner shall be resolved following the statutory procedure unless the Owner has elected to resolve the dispute pursuant to Public Contract Code SS 10240 et seq.

1. All claims shall be submitted in writing and accompanied by substantiating documentation. Claims must be filed on or before the date of final payment unless other notice requirements are provide in the contract. "Claim" means a separate demand by the claimant for (1) a time extension, (2) payment of money or damages arising from work done by or on behalf of the claimant and payment of which is not otherwise expressly provided for or the claimant is not otherwise entitled, or (3) an amount the payment of which is disputed by the Owner.
 - (a) Claims Under or equal to \$50,000. The Owner shall respond in writing to the claim within 45 days of receipt of the claim, or, the Owner may request, in writing, within 30 days of receipt of the claim, any additional documentation supporting the claim or relating to defenses or claims the Owner may have. If additional information is needed thereafter, it shall be provided upon mutual agreement of the Owner and the claimant. The Owner's written response shall be submitted 15 days after receiving the additional documentation, or within the same period of time taken by the claimant to produce the additional information, whichever is greater.
 - (b) Claims over \$50,000 but less than or equal to \$375,000. The Owner shall respond in writing within 60 days of receipt, or, may request in writing within 30 days of receipt of the claim, any additional documents supporting the claim or relating to defenses or claims the Owner may have against the claimant. If additional information is needed thereafter, it shall be provided pursuant to mutual agreement between the Owner and the claimant. The Owner's response shall be submitted within 30 days after receipt of the further documents, or within the same period of time taken by the claimant to produce the additional information or documents, whichever is greater.
2. If the claimant disputes the Owner's response, or if the Owner fails to respond within the statutory time period, the claimant may so notify the Owner within 15 days of the receipt of the response or the failure to respond,

and demand an informal conference to meet and confer for settlement. Upon such demand, the Owner shall schedule a meet and confer conference within 30 days.

3. If following the meet and confer conference, the claim or any portion thereof remains in dispute, the claimant may file a claim pursuant to Government Code SS 900 et seq. and Government Code SS 910 et seq. For purposes of those provisions, the time within which a claim must be filed shall be tolled from the time the claimant submits the written claim until the time the claim is denied, including any time utilized for the meet and confer conference.
4. If a civil action is filed to resolve any claim, the provisions of Public Contract Code SS 20104.4 shall be followed, providing for non-binding mediation and judicial arbitration.

SS 23. DUST ABATEMENT:

Dust control shall conform to Section 10, "Dust Control", Section 7-1.01F, "Air Pollution Control", Section 17, "Watering", and Section 18, "Dust Palliative" of the Standard Specifications, Rules no. 401, 402, 403 and 403.1 of the South Coast Air Quality Management District (AQMD), Riverside County Code, Chapter 8.52, "Fugitive Dust Reduction Program For Coachella Valley", all other applicable Federal and State laws, and the requirements set forth herein.

The Contractor is cautioned that failure to control fugitive dust may result in fines being levied by the South Coast Air Quality Management District to both the Contractor and the County of Riverside, as owner. The Contractor shall be fully responsible for payment of all fines pertaining to air pollution control violations, resulting from Contractor's operations related to the construction contract, which may be levied against both the Contractor and the County of Riverside by the AQMD or other regulatory agencies. The Contractor's attention is directed to Section 7-1.01, "Laws to be Observed" of the Standard Specifications. The cost of all fines levied against the County of Riverside will be deducted from any moneys due or which may become due to the Contractor, unless other payment arrangements are made by the Contractor.

Dust control of all of the Contractor's operations is required 24 hours per day, 7 days a week for the duration of the contract, and until the disturbed soil is permanently stabilized. The Contractor shall take every precaution to prevent emissions of fugitive dust from the project site, from locations of stockpiled materials, from unpaved driving surfaces, from haul vehicles, from inactive construction

areas, and from all other operations of the Contractor. The Contractor shall plan for and carry out proper and efficient measures to prevent his operations from producing dust in amounts damaging to property or which constitute a public nuisance, or which cause harm to persons living or working in the vicinity of the work. Of particular concern are emissions of PM10 particles, which are fine particulate matter of 10 microns or less and which are associated with sickness and death from respiratory disease.

The Contractor shall furnish and post dust mitigation signs, which shall be, at a minimum, in accordance with the "AQMD Signage Recommendations", attached hereto. Additional copies are available upon request from the Engineer. The sign shall include the Contractor's phone number which shall be maintained on a 24 hour basis. The sign message, size and design, including any deviations from the signage recommendations, shall be approved by the Engineer prior to fabrication.

The Contractor shall respond to complaints by mobilizing equipment and personnel at the construction site within 2 hours of each complaint to control fugitive dust.

Attention is directed to AQMD Rule 403.1, which applies to all contracts within the Coachella Valley Area of Riverside County. That AQMD Rule requires the Contractor to take specified dust control actions when prevailing wind speeds exceed 25 miles per hour. Wind forecasts, AQMD Rules and other related information are provided by AQMD at 1-800-CUT-SMOG and at www.aqmd.gov.

Any days on which the Contractor is prevented from working, due to the requirements of AQMD Rules, will be considered as non-working days, in accordance with Section 8-1.06, "Time of Completion" of the Standard Specifications.

The Contractor shall utilize the "Best Available Control Measures" of controlling fugitive dust, as prepared by the AQMD. For projects within the Coachella Valley, the "Reasonably Available Control Measures" may be employed, if effective within the context of the AQMD rules. However, if fugitive dust crosses the project boundary, more effective control measures, including the "Best Available Control Measures" shall be implemented.

A site-specific fugitive dust control plan shall be submitted to the Engineer for review and approval at least 10 days prior to the start of construction. Additionally, for projects outside of the Coachella Valley which meet the criteria for AQMD plan approval, the Contractor shall submit the dust control plan to AQMD for approval. AQMD plan submittal criteria is defined in AQMD Rule 403 as being for projects that will have disturbed surface area in excess of

100 acres, or for projects with a scope of work which requires the movement of more than 10,000 cubic yards of soil on each of any three working days.

A sample plan and other pertinent information is attached, and additional copies are available from the Engineer upon request. The fugitive dust control plan shall include the "Reasonably Available Control Measures" and "Best Available Control Measures" of controlling fugitive dust, as may be appropriate and necessary, including but not limited to watering, application of chemical dust suppressants, wind fencing, covering of haul vehicles, haul vehicle bed-liners, covering or chemically stabilizing stored materials, phased grading, planting of vegetation, the use of a 24 hour environmental observer, and track-out controls at locations where unpaved construction accesses intersect with paved roads. The use of chemical stabilizers, which are approved by all environmental regulatory agencies, and the use of reclaimed water is encouraged. If water is intended as a primary dust control tool, the dust control plan shall provide for at least one 2,000 gallon water truck for every 4 acres of disturbed soil, unless otherwise approved by the Engineer.

If the Construction Engineer determines that the project scope and the forecasted weather conditions are such that the Contractor's work is unlikely to be a source of dust emissions, the Construction Engineer has the authority to waive the requirements for submittal of a dust control plan and for placement of the dust control signs described herein. However, the Contractor's responsibilities for the control of fugitive dust and the other requirements of this section may not be waived.

A completion notice will not be filed, and the final payment will not be made to the Contractor until the areas of disturbed soil on the construction site, including roadway shoulders, are suitably stabilized for long term control of fugitive dust.

The successful Contractor shall attend an AQMD PM10 Dust Control Program training session, and furnish evidence of attendance to the Engineer. Attendance at AQMD training seminars can be scheduled through AQMD at 1-866-861-DUST (1-866-861-3878) or by email to dustcontrol@aqmd.gov. Current AQMD certification of previous attendance will be accepted. At that training session, the successful Contractor will be furnished with the AQMD prepared Rule 403 and Rule 403.1 implementation handbooks, which include the "Best Available Control Measures" and "Reasonably Available Control Measures", and other associated information, including a listing of suggested dust control related devices, materials and chemicals.

The signature of the Contractor on the Proposal constitutes acknowledgement by the Contractor of the dust control requirements established by law and described herein, and the enforceability of those requirements.

When the contract includes a bid item for Dust Abatement, full compensation for conformance with these dust abatement requirements, including labor, equipment, materials, developing water supply and incidentals, shall be paid at the lump sum price for Dust Abatement, and no additional compensation will be allowed therefor.

When the contract does not include a bid item for Dust Abatement, full compensation for conformance with these dust abatement requirements, including labor, equipment, materials, developing water supply and incidentals, shall be considered as included in the various items of work, and no additional compensation will be allowed therefor.

AQMD SIGNAGE RECOMMENDATIONS

November, 2001

Plan holder shall post signage at specified locations on the subject property in accordance with the standards specified below. The exception to the standards is that all letters shall be 4 inches high, with the names and telephone numbers of appropriate contacts and services in bold print, as indicated in the standards. These signs shall also include the SCAQMD toll free complaint line 1-800-CUT-SMOG (1-800-288-7664) and the telephone number for the Environmental Observer. These signs shall be posted within 50 feet of the curb on all four (4) corners of the subject property.

For each Dust Control Plan aggregating less than, or equal to, ten (10) acres:

1. The applicant shall install a sign on such property which is visible to the public that meets the following requirements:
 - (a) Such sign shall measure at least four (4) feet wide by four (4) feet high and conform to the specifications in 1 (a) below.

For each Dust Control Plan aggregating over ten (10) acres:

2. The applicant shall install a sign on such property which is visible to the public that meets the following requirements:
 - (a) Such sign shall measure at least eight (8) feet wide by four (4) feet high and conform to the specifications in 1 (b) below.

THE SIGN SHALL CONFORM TO THE FOLLOWING REQUIREMENTS:

1. The sign boards shall be constructed with materials capable of withstanding the environment in which they are placed.
 - (a) For 4' x 4' signs, the District recommends the following:
 - I. 3/4" A/C laminated plywood board
 - II. Two 4" x 4" posts
 - III. The posts should be attached to the edges of the plywood board with at least 2 carriage bolts on each post.
 - IV. The front surface of the sign board should be painted in the contrasting color of a white background with black lettering.
 - (b) For 4' x 8' signs, the District recommends the following:
 - I. 1" A/C laminated plywood board
 - II. Two 5" x 6" posts
 - III. The posts should be attached to the 4' edges of the plywood board with at least 2 carriage bolts on each post.
 - IV. The front surface of the sign board should be painted in the contrasting color of a white background with black lettering.

2. The sign board shall be installed and maintained in a condition such that members of the public can easily view, access, and read the sign at all times until the expiration date of the Dust Control plan.

(a) For 4' x 4' signs, the District recommends the following:

- I. The lower edge of the sign board should be mounted at least 2' above the existing ground surface to facilitate ease of viewing.
- II. The posts should be set in a hole at least 3' deep with concrete footings to preclude downing by high winds.
- III. On the construction site, the sign should be positioned such that nothing obstructs the public's view from the primary street access point.
- IV. For construction projects that are developed in phases, the sign should be moved to the area that is under active construction.
- V. In situations where all phases of the construction project are completed on a property prior to expiration of the Dust Control Plan, a written request for cancellation of the Dust Control Plan must be submitted to the Engineer.

(b) For 4' x 8' signs, the District recommends the following:

- I. The lower edge of the sign board should be mounted at least 2' above the existing ground surface to facilitate ease of viewing.
- II. The posts should be set in a hole at least 4' deep with concrete footings to preclude downing by high winds.
- III. On the construction site, the sign should be positioned such that nothing obstructs the public's view from the primary street access point.
- IV. For construction projects that are developed in phases, the sign should be moved to the area that is under active construction.
- V. In situations where all phases of the construction project are completed on a property prior to expiration of the Dust Control Plan, a written request for cancellation of the Dust Control Plan must be submitted to the Engineer.

3. **The sign board shall contain the following information:**

- (a) Project Name
- (b) Name of Prime Contractor
- (c) Phone Number of Contractor's Employee Responsible for Dust Control Matters
- (d) County designated phone number (to be provided by the Engineer)
- (e) South Coast Air Quality Management District Phone Number

4. The sign board shall be designed to the following alpha and numeric text dimensions (sign boards written in longhand are unacceptable).

(a) For a permittee subject to the 4' x 4' sign requirement, the District provides the following example: (as modified by the County of Riverside for use on County Public Works projects)

1" UPPERCASE Letters →	PROJECT NAME:		3 ½" Title Case Bold Letters ←
1" UPPERCASE Letters →	CONTRACTOR		3 ½" Title Case Bold Letters ←
1" Title Case Letters →	Contractor's Dust Control Phone #		3" Bold Numbers ←
1" Title Case Letters →	County of Riverside Phone #		3" Bold Numbers ←
1" Title Case Letters →	Phone Number:	SCAQMD 1-800-CUT-SMOG	3 ½" Bold Numbers ←

"Title Case" means the first letter of a word is capitalized and subsequent letters are lower case.

(b) For a permittee subject to the 4' x 8' sign requirement, the District provides the following example: (as modified by the County of Riverside)

2" UPPERCASE Letters	PROJECT NAME:		4" Title Case Bold Letters
2" UPPERCASE Letters	CONTRACTOR		4" Title Case Bold Letters
2" Title Case Letters	Contractor's Dust Control Phone #		4" Bold Numbers
2" Title Case Letters	County of Riverside Phone #	909-	4" Bold Numbers
2" Title Case Letters	Phone Number:	SCAQMD 1-800-CUT-SMOG	4 1/2" Bold Numbers
2" Title Case Letters	COUNTY OF RIVERSIDE TRANSPORTATION DEPARTMENT		

Plan Review Checklist Clearing/Grubbing/Mass Grading Phase

If feasible, use grading permit conditions to break the project into phases so that only a portion of the site is disturbed at any given time to ensure control of fugitive dust. This technique is critical for project sites with greater than 100 acres.

Prior to initiating activity, pre-water site through use of portable irrigation lines. At least 72 hours of pre-watering is recommended for each area prior to initiating earth-movement. Require the Applicant to specify water source and available flow rate (g/m).

Water applied continuously to all disturbed portions of the site by means of water truck/water pull as necessary to maintain sufficient visible moisture on the soil surface. For reference, one 2,000 gallon water truck can treat approximately 4 acres of active construction per hour. Also, for cut and fill activities, one 10,000 gallon water pull is estimated to be necessary for each 7,000 cubic yards of daily earth-movement. Multiple 4,000-gallon water trucks may be used in place of one 10,000-gallon water pull. Touch and visual contrast are reasonably good indicators of soil moisture. Surface areas that are dry to the touch and appear lighter-colored require the application of additional water to prevent visible or fugitive dust. Require the Applicant to specify the number of watering vehicles available for dust control during mass grading and during off-hours as well as availability of back-up water trucks if the site experiences dust control problems.

Water towers are necessary for projects with more than 10 acres of active construction. Without a water tower, it can take up to 30 minutes to fill a 2,000 gallon water truck. Also, multiple water towers are necessary for projects that use water pulls as filling one 10,000 gallon water pull can drain a water tower which takes up to 40 minutes to refill.

Wind fencing is necessary between the site and nearby residences or businesses. Off-site upwind fencing and on-site wind fencing for larger projects can also keep blowsand from being deposited onto the site or traveling through the site.

A perimeter watering system consisting of portable irrigation equipment may be an effective mitigation system to protect surrounding residences and businesses. The portable watering system may be used in place of or in conjunction with watering trucks. The local jurisdiction may also be provided access to this equipment.

Remember...
DUST CONTROL IS REQUIRED 24 HOURS A DAY, 7 DAYS A WEEK,
REGARDLESS OF CONSTRUCTION STATUS

Section 1

Simplified Sample Site Plan

Existing Residential

Distance and location of nearest:
Residence _____
Business _____

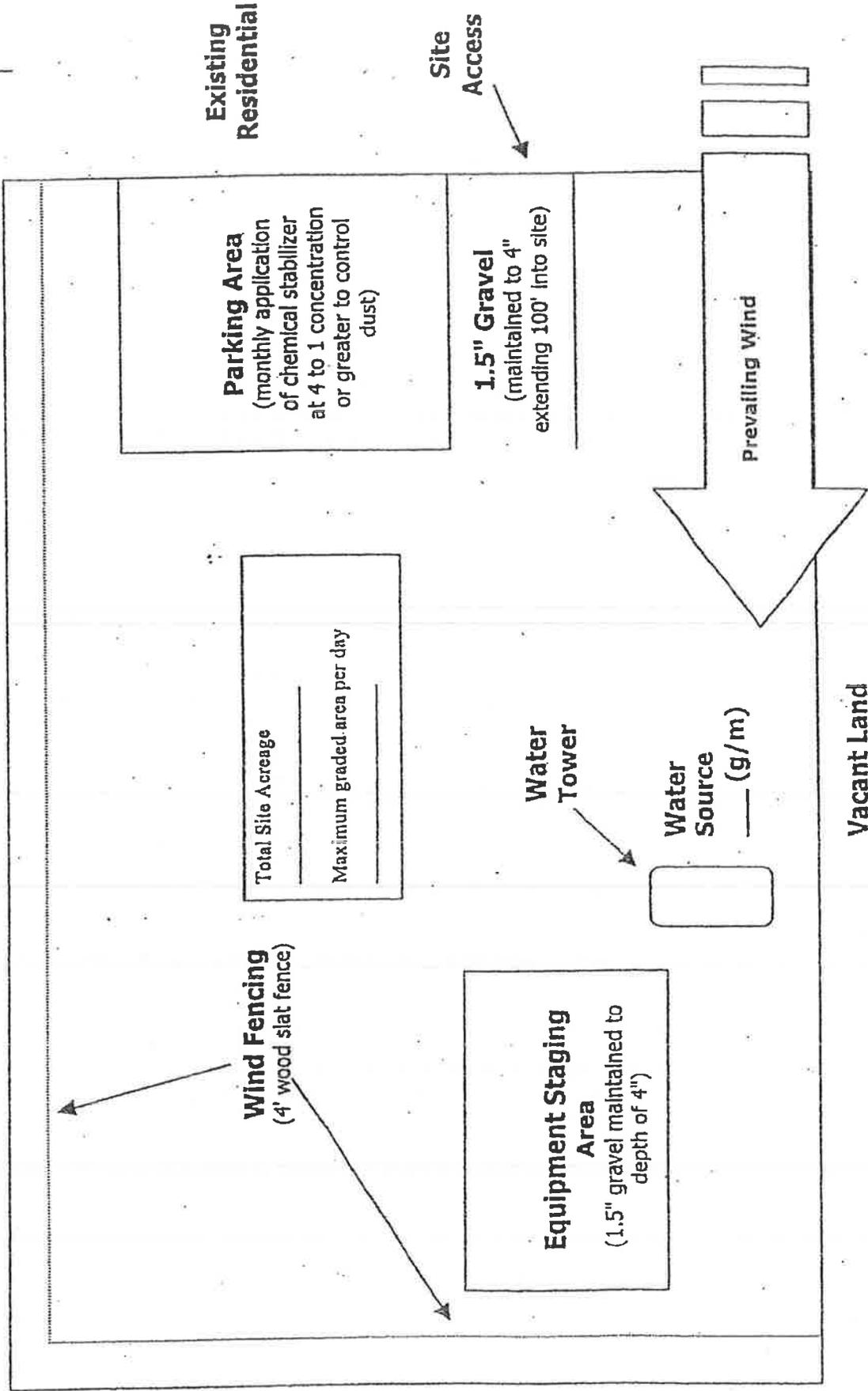
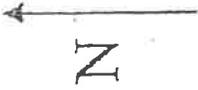

Existing Residential

Remember...
DUST CONTROL IS REQUIRED 24 HOURS A DAY, 7 DAYS A WEEK,
REGARDLESS OF CONSTRUCTION STATUS

- Construction site accesses are to be improved with 1.5" gravel maintained to a depth of 4" , at least 20' wide, and extending 100 feet into the site. If the project site is not balanced, a wheel washing system and/or ribbed steel plates should be placed in the roadway before the vehicle enters the graveled area to clean the tires and prevent trackout.
- Equipment staging areas are to be treated with 1.5" gravel maintained to a depth of 4".
- Employee parking areas are to be covered with 1.5" gravel maintained to a depth of 4" or treated with chemical dust suppressants at a 4 to 1 ratio on at least a monthly basis to prevent fugitive dust.
- Chemical dust suppressants are to be mixed at a ratio of 20 to 1 and applied to all disturbed surfaces that are proposed to remain inactive for a period of at least 10 consecutive days. These products are effective in preventing and controlling dust. Recordkeeping is necessary to demonstrate compliance.
- All project sites greater than 100 acres shall monitor daily wind speeds and AQMD forecasted wind events (call 1.800.CUT.SMOG; press one for air quality information, and then press five for Coachella Valley wind forecasts). Operators shall maintain these records for review by any local code enforcement officer or AQMD inspector.
- An environmental observer whose primary duty is to oversee dust control at the site is to be used for construction projects greater than 100 acres and/or sites with more than 50 acres of active construction. The environmental observer is tasked with monitoring dust abatement measures and authorized to deploy additional water trucks and other dust control actions (i.e., wind fencing, street sweepers, chemical dust suppressants, etc.) as necessary to prevent or control fugitive dust.
- Other (specify): _____

Remember...
DUST CONTROL IS REQUIRED 24 HOURS A DAY, 7 DAYS A WEEK,
REGARDLESS OF CONSTRUCTION STATUS

Plan Review Checklist Finish Grading Phase

- Water applied continuously to all disturbed portions of the site by means of water truck/water pull as necessary to maintain sufficient visible moisture on the soil surface. For reference, one 2,000 gallon water truck can treat approximately 4 acres of active construction per hour. Also, for cut and fill activities, one 10,000 gallon water pull is estimated to be necessary for each 7,000 cubic yards of daily earth-movement. Multiple 4,000-gallon water trucks may be used in place of a 10,000-gallon water pull. Touch and visual contrast are reasonably good indicators of soil moisture. Surface areas that are dry to the touch and appear lighter-colored require the application of additional water to prevent visible or fugitive dust. Require the Applicant to specify the number of watering vehicles available for dust control during finish grading and during off-hours as well as availability of back-up water trucks if the site experiences dust control problems.
- Water towers are necessary for projects with more than 10 acres of active construction. Without a water tower, it can take up to 30 minutes to fill a 2,000 gallon water truck. Also, multiple water towers are necessary for projects that use water pulls as filling one 10,000 gallon water pull can drain a water tower which takes up to 40 minutes to refill.
- Wind fencing is necessary between the site and nearby residences or businesses to reduce fugitive dust. Off-site upwind fencing and on-site wind fencing for larger projects can also keep blowsand from being deposited onto the site or traveling through a site.
- Chemical dust suppressants are to be applied at a concentration of at least 10 to 1 to finish graded areas once final elevations have been reached. For areas that will remain inactive for longer periods, vegetation can be a cost-effective alternative to chemical stabilization. Wind fencing or other obstructions can keep the stabilized area free from future disturbances.
- Construction site access(es) are to be improved with 1.5" gravel maintained to a depth of at least 4" with a minimum width of at least 20', extending 100 feet into the project site.
- Equipment staging areas are to be treated with 1.5" gravel maintained to a depth of 4".
- Internal roadway networks are to be treated with chemical dust suppressants at a minimum rate of at least 4 to 1 and retreated on a monthly basis once final roadway elevations have been reached.
- Employee parking areas are to be treated with chemical dust suppressants at a mix ratio of at least 4 to 1 and retreated on at least a monthly basis or covered with 1.5" gravel maintained to a depth of 4" to prevent fugitive dust.
- Other (specify): _____

Remember...
DUST CONTROL IS REQUIRED 24 HOURS A DAY, 7 DAYS A WEEK,
REGARDLESS OF CONSTRUCTION STATUS

Plan Review Checklist Construction Phase

- Water applied continuously to all disturbed portions of the site by means of water truck/water pull is necessary to maintain sufficient visible moisture on the soil surface. For reference, one 2,000 gallon water truck can treat approximately 4 acres of active construction per hour. Touch and visual contrast are reasonably good indicators of soil moisture. Surface areas that are dry to the touch and appear lighter-colored require the application of additional water to prevent visible or fugitive dust. Require the Applicant to specify the number of watering vehicles available for dust control during the construction phase and during off-hours as well as availability of back-up water trucks if the site experiences dust control problems.

- Wind fencing is necessary between the site and nearby residences or businesses. Off-site upwind fencing and on-site wind fencing for larger projects can also keep blowsand from being deposited onto the site or traveling through the site. Block walls, if part of the final project, can replace wind fencing during the construction phase.

- Chemical dust suppressants are to be applied at a concentration of at least 20 to 1 to finish graded areas once final elevations have been reached. For areas that will remain inactive for longer periods, vegetation can be a cost-effective alternative to chemical stabilization. Wind fencing or other obstructions can keep the stabilized area free from future disturbances.

- Construction site accesses are to be improved with 1.5" gravel, maintained to a depth of 4", with a width of at least 20', extending 100' into the project site. Paving internal roadways can substitute for gravel.

- Internal roadway networks are to be paved as early as feasible in the construction phase. Street sweeping of internal and/or external access roads will likely be required to control entrained road dust.

- Employee parking areas are to be treated with chemical dust suppressants at a mix ratio of no less than 4 to 1 and retreated on a monthly basis, or more frequently if fugitive dust is observed. If internal roadway is complete, employees are to be instructed to park on paved roads.

- Other (specify): _____

Remember...
DUST CONTROL IS REQUIRED 24 HOURS A DAY, 7 DAYS A WEEK,
REGARDLESS OF CONSTRUCTION STATUS

RULE 403 IMPLEMENTATION HANDBOOK

REASONABLY AVAILABLE CONTROL MEASURES

Paragraph (d)(3) of Rule 403 allows activities outside the South Coast Air Basin (see Figure 2-1) to implement reasonably available control measures in lieu of best available control measures. Additionally, as specified by subparagraph (f)(3)(D) of Rule 403, any person seeking approval of a fugitive dust emissions control plan for projects outside the South Coast Air Basin must demonstrate to the satisfaction of the District that the given activity is employing all reasonably available fugitive dust control measures.

The District has prepared the attached listing of reasonably available fugitive dust control measures for a variety of source categories. This list is based on the U.S. Environmental Protection Agency's reference document entitled, "Control of Open Fugitive Dust Sources," Midwest Research Institute, September 1988.

The District encourages the use of those dust control measures that minimize the use of potable water. When water is needed, reclaimed water should be utilized to the greatest extent feasible.

RULE 403 IMPLEMENTATION HANDBOOK

REASONABLY AVAILABLE CONTROL MEASURES

The left column contains a listing of the sources of fugitive dust which are intended for emission control under District Rule 403 and a listing of control measures and high-wind measures. The right column contains a description of the reasonably available fugitive dust control measures for each of the sources.

Source: (1) Land Clearing/Earth-Moving

CONTROL MEASURES

DESCRIPTION

- | | |
|--------------------------------|--|
| (A) Watering | (1) Application of water by means of trucks, hoses and/or sprinklers prior to conducting any land clearing. This will increase the moisture content of the soils; thereby increasing its stability. |
| | (2) Pre-application of water to depths of proposed cuts. |
| | (3) Once the land clearing/earth moving activities are complete, a second application of water can generate a thin crust that stabilizes the disturbed surface area provided that it is not disturbed. (Security fencing can be used to prevent unwanted future disturbances of sites where a surface crust has been created). |
| (B) Chemical stabilizers | (1) Only effective in areas which are not subject to daily disturbances. |
| | (2) Vendors can supply information on product application and required concentrations to meet the specifications established by the Rule. |
| (C) Wind fencing | (1) Three- to five-foot barriers with 50% or less porosity located adjacent to roadways or urban areas can be effective in reducing the amount of windblown material leaving a site. |
| | (2) Would likely be used in conjunction with other measures (e.g., watering, chemical stabilization, etc.) to ensure that visible emissions do not cross a property line. |
| (D) Cover haul vehicles | (1) Entire surface area of hauled earth should be covered once vehicle is full. |
| (E) Bedliners in haul vehicles | (1) When feasible, use in bottom-dumping haul vehicles. |

HIGH WIND MEASURE

- (a) Cease all active operations; or
(b) Apply water within 15 minutes to any soil surface which is being moved or otherwise disturbed.

Source: (2) Unpaved Roads

CONTROL MEASURES

(F) Paving

(G) Chemical stabilization

(H) Watering

(I) Reduce speed limits

(J) Reduce vehicular trips

(K) Gravel

HIGH WIND MEASURE

- (c) Apply a chemical stabilizer (to meet the specifications established by the Rule) prior to wind events; or
- (d) Apply water once each hour; or
- (e) Stop all vehicular traffic.

DESCRIPTION

- (1) Requires street sweeping/cleaning if subject to material accumulation.
- (1) Vendors can supply information as to application methods and concentrations to meet the specifications established by the Rule
- (2) Not recommended for high volume or heavy equipment traffic use.
- (1) In sufficient quantities to keep surface moist.
- (2) Required application frequency will vary according to soil type, weather conditions, and vehicular use.
- (1) 15 mile per hour maximum. May need to be used in conjunction with watering or chemical stabilization to prevent visible emissions from crossing the property line.
- (1) Access restriction or redirecting traffic to reduce vehicle trips by a minimum of 60 percent.
- (1) Gravel maintained to a depth of four inches can be an effective measure.
- (2) Should only be used in areas where paving, chemical stabilization or frequent watering is not feasible.

RULE 403 IMPLEMENTATION HANDBOOK

Source: (3) Storage Piles

CONTROL MEASURES

(L) Wind sheltering

DESCRIPTION

- (1) Enclose in silos.
- (2) Install three-sided barriers equal to height of material, with no more than 50 percent porosity.

(M) Watering

- (1) Application methods include: spray bars, hoses and water trucks.
- (2) Frequency of application will vary on site-specific conditions:

(N) Chemical stabilizers

- (1) Best for use on storage piles subject to infrequent disturbances.

(O) Altering load-in/load-out procedures

- (1) Confine load-in/load-out procedures to leeward (downwind) side of the material.
- (2) May need to be used in conjunction with wind sheltering to prevent visible emissions from crossing the property line.

(P) Coverings

- (1) Tarps, plastic, or other material can be used as a temporary covering.
- (2) When used, these should be anchored to prevent wind from removing coverings.

HIGH WIND MEASURE

- (f) Apply chemical stabilizers (to meet the specifications established by the Rule) prior to wind events; or
- (g) Apply water once per hour; or
- (h) Install temporary covers.

Source: (4) Paved Road Track-Out

CONTROL MEASURES

(Q) Chemical stabilization

DESCRIPTION

- (1) Most effective when used on areas where active operations have ceased.
- (2) Vendors can supply information on methods for application and required concentrations.

(R) Sweep/clean roadways

- (1) Either sweeping or water flushing may be used.

(S) Cover haul vehicles

- (1) Entire surface area should be covered once vehicle is full.

(T) Bedliners in haul vehicles

- (1) When feasible, use in bottom dumping vehicles.

(U) Site access improvement

- (1) Pave internal roadway system.
- (2) Most important segment, last 100 yards from the connection with paved public roads

HIGH WIND MEASURE

- (i) Cover all haul vehicles; and
- (j) Clean streets with water flushing, unless prohibited by the Regional Water Quality Control Board.

RULE 403 IMPLEMENTATION HANDBOOK

Source: (5) Disturbed Surface Areas/Inactive Construction Sites

CONTROL MEASURES

DESCRIPTION

- (Q) Chemical stabilization
 - (1) Most effective when used on areas where active operations have ceased.
 - (2) Vendors can supply information on methods for application and required concentrations.
- (R) Watering
 - (1) Requires frequent applications unless a surface crust can be developed.
- (S) Wind fencing
 - (1) Three- to five-foot barriers with 50% or less porosity adjacent to roadways or urban areas can be effective in reducing the amount of wind blown material leaving a site.
- (T) Vegetation
 - (1) Establish as quickly as possible when active operations have ceased.
 - (2) Use of drought tolerant, native vegetation is encouraged.

HIGH WIND MEASURES

- (k) Apply chemical stabilizers (to meet the specifications established by the Rule); or
- (l) Apply water to all disturbed surface areas 3 times per day.

BEST AVAILABLE CONTROL MEASURES

Rule 403, paragraph (d)(2) requires active operations [defined in Rule 403, paragraph (c)(1)] within the South Coast Air Basin (see Figure 2-1) to implement at least one best available control measure for each fugitive dust source type on site. Additionally, as specified by subparagraph (f)(3)(D) of Rule 403, any person seeking approval of a fugitive dust emissions control plan for projects within the South Coast Air Basin must demonstrate to the satisfaction of the AQMD that the given activity is employing all best available fugitive dust control measures.

The AQMD has prepared the attached listing of best available fugitive dust control measures for a variety of source categories. This list is based on the U.S. Environmental Protection Agency's reference document entitled, "Fugitive Dust Background Document and Technical Information Document for Best Available Control Measures," Office of Air and Radiation, September 1992.

The AQMD encourages the use of those dust control measures that minimize the use of potable water. When water is needed, reclaimed water should be utilized to the greatest extent feasible.

RULE 403 IMPLEMENTATION HANDBOOK

BEST AVAILABLE CONTROL MEASURES

The left column contains a listing of the sources of fugitive dust which are intended for emission control under District Rule 403 and a listing of control measures and high-wind measures. The right column contains a description of the best available fugitive dust control measures for each of the sources.

Source: (1) Land Clearing/Earth-Moving

CONTROL MEASURES

DESCRIPTION

- | | |
|--------------------------------|---|
| (A) Watering (pre-grading) | (1) Application of water by means of trucks, hoses and/or sprinklers prior to conducting any land clearing. This will increase the moisture content of the soils; thereby increasing its stability. |
| (A-1) Watering (post-grading) | (2) Pre-application of water to depths of proposed cuts. |
| (A-2) Pre-grading planning | (1) In active earth-moving areas water should be applied at sufficient frequency and quantity to prevent visible emissions from extending more than 100 feet from the point of origin. |
| (B) Chemical stabilizers | (1) Grade each phase separately, timed to coincide with construction phase; or
(2) Grade entire project, but apply chemical stabilizers or ground cover to graded areas where construction phase begins more than 60 days after grading phase ends. |
| (C) Wind fencing | (1) Only effective in areas which are not subject to daily disturbances.
(2) Vendors can supply information on product application and required concentrations to meet the specifications established by the Rule. |
| (D) Cover haul vehicles | (1) Three- to five-foot barriers with 50% or less porosity located adjacent to roadways or urban areas can be effective in reducing the amount of windblown material leaving a site. Must be implemented in conjunction with either measure (A-1) or (B). |
| (E) Bedliners in haul vehicles | (1) Entire surface area of hauled earth should be covered once vehicle is full.
(1) When feasible, use in bottom-dumping haul vehicles. |

HIGH WIND MEASURE

- (a) Cease all active operations; or
(b) Apply water within 15 minutes to any soil surface which is being moved or otherwise disturbed.

RULE 403 IMPLEMENTATION HANDBOOK

Source: (2) Unpaved Roads

CONTROL MEASURES

DESCRIPTION

- | | |
|----------------------------|---|
| (F) Paving | (1) Requires street sweeping/cleaning if subject to material accumulation. |
| (G) Chemical stabilization | (1) Vendors can supply information as to application methods and concentrations to meet the specifications established by the Rule
(2) Not recommended for high volume or heavy equipment traffic use. |
| (H) Watering | (1) In sufficient quantities to keep surface moist.
(2) Required application frequency will vary according to soil type, weather conditions, and vehicular use. |
| (I) Reduce speed limits | (1) 15 mile per hour maximum. May need to be used in conjunction with watering or chemical stabilization to prevent visible emissions from crossing the property line. |
| (J) Reduce vehicular trips | (1) Access restriction or redirecting traffic to reduce vehicle trips by a minimum of 60 percent. |
| (K) Gravel | (1) Gravel maintained to a depth of four inches can be an effective measure.
(2) Should only be used in areas where paving, chemical stabilization or frequent watering is not feasible. |

HIGH WIND MEASURE

- (a) Apply a chemical stabilizer (to meet the specifications established by the Rule) prior to wind events; or
(b) Apply water once each hour; or
(c) Stop all vehicular traffic.

RULE 403 IMPLEMENTATION HANDBOOK

Source: (3) Storage Piles

CONTROL MEASURES

DESCRIPTION

- | | |
|--|--|
| (L) Wind sheltering | (1) Enclose in silos.
(2) Install three-sided barriers equal to height of material, with no more than 50 percent porosity. |
| (M) Watering | (1) Application methods include: spray bars, hoses and water trucks.
(2) Frequency of application will vary on site-specific conditions. |
| (N) Chemical stabilizers | (1) Best for use on storage piles subject to infrequent disturbances. |
| (O) Altering load-in/load-out procedures | (1) Confine load-in/load-out procedures to leeward (downwind) side of the material.
Must be used in conjunction with either measure (L), (M), (N), or (P). |
| (P) Coverings | (1) Tarps, plastic, or other material can be used as a temporary covering.
(2) When used, these should be anchored to prevent wind from removing coverings. |

HIGH WIND MEASURE

- (a) Apply chemical stabilizers (to meet the specifications established by the Rule) prior to wind events; or
(b) Apply water once per hour; or
(c) Install temporary covers.

RULE 403 IMPLEMENTATION HANDBOOK

Source: (4) Paved Road Track-Out

CONTROL MEASURES

DESCRIPTION

Compliance with District Rule 403.

Paragraph (d)(5).

January 1999

RULE 403 IMPLEMENTATION HANDBOOK

Source: (5) Disturbed Surface Areas/ Inactive Construction Sites

CONTROL MEASURES

DESCRIPTION

- (Q) Chemical stabilization
 - (R) Watering
 - (S) Wind fencing
 - (T) Vegetation
- (1) Most effective when used on areas where active operations have ceased.
 - (2) Vendors can supply information on methods for application and required concentrations.
 - (1) Requires frequent applications unless a surface crust can be developed.
 - (1) Three- to five-foot barriers with 50% or less porosity adjacent to roadways or urban areas can be effective in reducing the amount of wind blown material leaving a site. Must be used in conjunction with either measure (Q), (R), or (T).
 - (1) Establish as quickly as possible when active operations have ceased.

HIGH WIND MEASURES

- (a) Apply chemical stabilizers (to meet the specifications established by the Rule); or
- (b) Apply water to all disturbed surface areas 3 times per day.

* Use of drought tolerant, native vegetation is encouraged.

TABLE 1

BEST [REASONABLY]* AVAILABLE CONTROL MEASURES FOR HIGH WIND CONDITIONS

FUGITIVE DUST SOURCE CATEGORY	<u>CONTROL MEASURES</u>
Earth-moving	(1A) Cease all active operations; OR (2A) Apply water to soil not more than 15 minutes prior to moving such soil.
Disturbed surface areas	(0B) On the last day of active operations prior to a weekend, holiday, or any other period when active operations will not occur for not more than four consecutive days: apply water with a mixture of chemical stabilizer diluted to not less than 1/20 of the concentration required to maintain a stabilized surface for a period of six months; OR (1B) Apply chemical stabilizers prior to wind event; OR (2B) Apply water to all unstabilized disturbed areas 3 times per day. If there is any evidence of wind driven fugitive dust, watering frequency is increased to a minimum of four times per day; OR (3B) Take the actions specified in Table 2, Item (3c); OR (4B) Utilize any combination of control actions (1B), (2B), and (3B) such that, in total, these actions apply to all disturbed surface areas.
Unpaved roads	(1C) Apply chemical stabilizers prior to wind event; OR (2C) Apply water twice [once] per hour during active operation; OR (3C) Stop all vehicular traffic.
Open storage piles	(1D) Apply water twice [once] per hour; OR (2D) Install temporary coverings.
Paved road track-out	(1E) Cover all haul vehicles; OR (2E) Comply with the vehicle freeboard requirements of Section 23114 of the California Vehicle Code for both public and private roads.
All Categories	(1F) Any other control measures approved by the Executive Officer and the U.S. EPA as equivalent to the methods specified in Table 1 may be used.

* Measures in [brackets] are reasonably available control measures and only apply to sources not within the South Coast Air Basin.

TABLE 2
DUST CONTROL ACTIONS FOR EXEMPTION FROM PARAGRAPH (d)(4)*

<u>FUGITIVE DUST SOURCE CATEGORY</u>	<u>CONTROL ACTIONS</u>
<p>Earth-moving (except construction cutting and filling areas, and mining operations)</p>	<p>(1a) Maintain soil moisture content at a minimum of 12 percent, as determined by ASTM method D-2216, or other equivalent method approved by the Executive Officer, the California Air Resources Board, and the U.S. EPA. Two soil moisture evaluations must be conducted during the first three hours of active operations during a calendar day, and two such evaluations each subsequent four-hour period of active operations; OR</p> <p>(1a-1) For any earth-moving which is more than 100 feet from all property lines, conduct watering as necessary to prevent visible dust emissions from exceeding 100 feet in length in any direction.</p>
<p>Earth-moving: Construction fill areas:</p>	<p>(1b) Maintain soil moisture content at a minimum of 12 percent, as determined by ASTM method D-2216, or other equivalent method approved by the Executive Officer, the California Air Resources Board, and the U.S. EPA. For areas which have an optimum moisture content for compaction of less than 12 percent, as determined by ASTM Method 1557 or other equivalent method approved by the Executive Officer and the California Air Resources Board and the U.S. EPA, complete the compaction process as expeditiously as possible after achieving at least 70 percent of the optimum soil moisture content. Two soil moisture evaluations must be conducted during the first three hours of active operations during a calendar day, and two such evaluations during each subsequent four-hour period of active operations.</p>

* Measures in [brackets] are reasonably available control measures and only apply to sources not within the South Coast Air Basin.

TABLE 2 (Continued)

<u>FUGITIVE DUST SOURCE CATEGORY</u>	<u>CONTROL ACTIONS</u>
Earth-moving: Construction cut areas and mining operations:	(1c) Conduct watering as necessary to prevent visible emissions from extending more than 100 feet beyond the active cut or mining area unless the area is inaccessible to watering vehicles due to slope conditions or other safety factors.
Disturbed surface areas (except completed grading areas)	(2a/b) Apply dust suppression in sufficient quantity and frequency to maintain a stabilized surface. Any areas which cannot be stabilized, as evidenced by wind driven fugitive dust must have an application of water at least twice per day to at least 80 [70] percent of the unstabilized area.
Disturbed surface areas: Completed grading areas	(2c) Apply chemical stabilizers within five working days of grading completion; OR (2d) Take actions (3a) or (3c) specified for inactive disturbed surface areas.
Inactive disturbed surface areas	(3a) Apply water to at least 80 [70] percent of all inactive disturbed surface areas on a daily basis when there is evidence of wind driven fugitive dust, excluding any areas which are inaccessible to watering vehicles due to excessive slope or other safety conditions; OR (3b) Apply dust suppressants in sufficient quantity and frequency to maintain a stabilized surface; OR (3c) Establish a vegetative ground cover within 21 [30] days after active operations have ceased. Ground cover must be of sufficient density to expose less than 30 percent of unstabilized ground within 90 days of planting, and at all times thereafter; OR (3d) Utilize any combination of control actions (3a), (3b), and (3c) such that, in total, these actions apply to all inactive disturbed surface areas.

* Measures in [brackets] are reasonably available control measures and only apply to sources not within the South Coast Air Basin.

TABLE 2 (Continued)

<u>FUGITIVE DUST SOURCE CATEGORY</u>	<u>CONTROL ACTIONS</u>
Unpaved Roads	(4a) Water all roads used for any vehicular traffic at least once per every two hours of active operations [3 times per normal 8 hour work day]; OR (4b) Water all roads used for any vehicular traffic once daily and restrict vehicle speeds to 15 miles per-hour; OR (4c) Apply a chemical stabilizer to all unpaved road surfaces in sufficient quantity and frequency to maintain a stabilized surface.
Open storage piles	(5a) Apply chemical stabilizers; OR (5b) Apply water to at least 80 [70] percent of the surface area of all open storage piles on a daily basis when there is evidence of wind driven fugitive dust; OR (5c) Install temporary coverings; OR (5d) Install a three-sided enclosure with walls with no more than 50 percent porosity which extend, at a minimum, to the top of the pile.
<u>All Categories</u>	(6a) Any other control measures approved by the Executive Officer and the U.S. EPA as equivalent to the methods specified in Table 2 may be used.

* Measures in [brackets] are reasonably available control measures and only apply to sources not within the South Coast Air Basin.

January 1999

TABLE 3
TRACK-OUT CONTROL OPTIONS

PARAGRAPH (d)(5)(B)

CONTROL OPTIONS

(1)	Pave or apply chemical stabilization at sufficient concentration and frequency to maintain a stabilized surface starting from the point of intersection with the public paved surface, and extending for a centerline distance of at least 100 feet and a width of at least 20 feet.
(2)	Pave from the point of intersection with the public paved road surface, and extending for a centerline distance of at least 25 feet and a width of at least 20 feet, and install a track-out control device immediately adjacent to the paved surface such that exiting vehicles do not travel on any unpaved road surface after passing through the track-out control device.
(3)	Any other control measures approved by the Executive Officer and the U.S. EPA as equivalent to the methods specified in Table 3 may be used.

January 1999

MECCA STREETS REVITALIZATION PROJECT - PHASE 3
66th AVENUE, DALE KILER ROAD AND HOME AVENUE

PROJECT NO. C1-0646

SPECIAL PROVISIONS

DESCRIPTIONS:

In general, this project consists of reconstructing portions of 66th Avenue, Dale Kiler Road and Home Avenue, in the Mecca area of Riverside County. The work involves reconstructing asphalt concrete pavement, removing and/or constructing concrete curb, gutter and sidewalk, tubular steel fence, trimming/removing trees and shrubs, constructing concrete driveway approaches, cross-gutter, curb ramps and decorative colored stamped concrete, installing/relocating roadside signs, placing thermoplastic crosswalk stripes, pavement markings and pavement markers, striping, flashing beacons, street lighting and other work as may be required.

SPECIFICATIONS:

This project shall conform to the requirements of the May 2006 edition of the Standard Specifications and Standard Plans as issued by the State of California Department of Transportation.

Requirements on the construction plans for Portland Cement Concrete are modified to the PCC Class designations, as described in Section 90-1.01 of the 2006 Standard Specifications, as follows:

Class ``A'' shall mean Class ``2"
Class ``B'' shall mean Class ``3"
Class ``C'' shall mean Class ``4"
Class ``D'' shall mean Class ``1"

DISPOSAL OF EXCESS EXCAVATION OR MATERIALS:

Excess earth excavation, pavement grindings and other excess materials resulting from construction operations shall be

disposed of by the Contractor outside of the highway right of way, as provided in Section 7-1.13 of the Standard Specifications.

The second paragraph of Section 7-1.13 of the Standard Specifications is modified to read as follows:

When any material is to be disposed of outside the highway right of way, and the County of Riverside has not made arrangements for the disposal of such material, the Contractor shall first obtain written authorization from the property owner on whose property the disposal is to be made and he shall file with the Engineer said authorization or a certified copy thereof together with a written release from the property owner absolving the County of Riverside from any and all responsibility in connection with the disposal of material on said property. If the disposal of materials is to be made at an established disposal facility that is available for public use, the Contractor shall retain all authorizations and receipts from said disposal facility and shall provide copies to the Engineer upon request.

RECORD DRAWINGS:

The Contractor shall keep one clean set of bond originals to note any changes which take place during construction. These changes to the original plans and/or specifications shall be noted at the appropriate locations with the appropriate changes indicated in red pencil or ink. The Contractor shall note in large letters ``RECORD DRAWINGS'' on the Title Sheet of the plans. The job will not be finalized by the Engineer until these record drawings have been completed to the satisfaction of the Engineer. The changes shall be noted on the plans as the changes occur. The record drawings shall be submitted to the Engineer, and become the property of the County at conclusion of the project.

Full compensation for maintaining and compiling the record drawings shall be considered to be included in other items of work and no additional compensation will be allowed therefor.

LIQUIDATED DAMAGES:

The Contractor shall diligently prosecute the work to completion before the expiration of 30 working days from the date stated in the "Notice to Proceed". The Contractor shall pay to the County of Riverside the sum of \$11,000.00 per calendar day, for each and every calendar day's delay in finishing the work in excess of the number of working days prescribed above.

In addition to the liquidated damages set forth above, the first lift of asphalt concrete paving shall be placed within seven (7) calendar days of the removal of existing asphalt concrete for each street segment. A street segment is hereby defined as that area of road removed in one (1) day. Contractor shall pay to the County of Riverside the sum of \$800.00 per day, for each and every calendar day's delay in completing paving within the number of calendar days prescribed above, for each street segment subjected to delay, and shall apply separately to each street segment within the scope of work.

INSURANCE:

In addition to the requirements of Section SS 18, "Insurance - Hold Harmless" of the contract documents, the Contractor's Certificate of Insurance and endorsements for the project shall name the following listed entities as additional insured under the Contractor's general liability, excess liability, and auto liability insurance policies, and each listed entity shall be named on the Waiver of Subrogation for the Contractor's Workers Compensation policy.

1. Coachella Valley Water District, its officers, directors, agents and employees.
2. Imperial Irrigation District, its officers, directors, agents and employees.
3. Redevelopment Agency for the County of Riverside, its officers, directors, agents and employees.

Each of the above listed entities shall also be held harmless, in accordance with the requirements of subsection IV, "Hold Harmless" of Section SS 18, "Insurance - Hold Harmless" of the contract documents.

Full compensation for compliance with the requirements of this Section shall be considered as included in the various items of work, and no additional compensation will be allowed therefor.

CONSTRUCTION SCHEDULE AND COOPERATION WITH UTILITY COMPANIES:

The Contractor is hereby notified that the Redevelopment Agency for the County of Riverside (RDA) will be installing an 18" domestic water pipeline within 66th Avenue. The Contractor will begin the street construction only after RDA has completed the water line construction. The County will issue a Notice to Proceed to the Contractor immediately after RDA's completion of the water line. The completion date for RDA's work is anticipated to be anytime between August 1, 2011 and September 30, 2011.

Attention is directed to section 7-1.14, "Cooperation" of the Standard Specifications and these Special Provisions.

The Contractor is hereby advised to cooperate with utility companies for adjustment of water valves, water meters, manholes and other facilities to grade and for any work being performed by the utility companies. Should construction be under way by other forces or by other Contractors within or adjacent to those limits, the Contractor shall cooperate with all other Contractors or other forces to the end that any delay or hindrance to work will be avoided. The right is reserved to perform other or additional work at or the near site (including material sources) at any time, by the use of other forces. Right of way delay claims will not be permitted with respect to any utility relocation work that has not been completed prior to October 15, 2011, as extra contract working days were allowed for such coordination. However, attention is directed to any utility windows that have been designated for work during construction, including, but not limited to IID street light pole relocations.

The Coachella Valley Water District will not lower their surface facilities within the paved areas for the Contractor. The Contractor is responsible to fully protect all utility facilities during the course of construction, in accordance with the Contract Documents, the Standard Specifications, and as directed by the Engineer.

ITEMS OF WORK:

TRAFFIC CONTROL SYSTEM:

Contractor shall prepare construction staging and traffic control plans for review and approval by the Transportation Department.

Proposed plans shall be submitted by the Contractor for review and approval by the Transportation Department at least two weeks prior to the start of construction. The construction staging and traffic control plans shall be prepared, signed and stamped by a Civil Engineer or Traffic Engineer who is registered as such in the State of California, unless otherwise specifically allowed by the Engineer. The Contractor shall revise and implement the plans as directed by the County's Engineer. Construction shall not begin until the Engineer provides Contractor with County approval of the plans.

Construction staging and traffic control plans shall be in accordance with the appropriate standards and specifications for construction staging, detour roads, traffic control, including the State of California Highway Design Manual, the 2006 California Manual of Uniform Traffic Control Devices (MUTCD), the May 2006 Standard Plans and Standard Specifications, and the Work Area Traffic Control Handbook (WATCH), as published by Building News, Inc. Any requests for deviation from the established design standards or specifications are to be submitted to the Engineer for review and approval prior to submission of the required plans.

With regard to the preparation and implementation of the plans, attention is especially directed to Sections 7-1.06, 7-1.08, 7-1.09, 7-1.11, 7-1.12 and Section 12 of the State of California Standard Specifications. Section 12-2.02 of the Standard Specifications is deleted.

Maintaining traffic shall conform to the provisions in 7-1.02 "Load Limitations", 7-1.06 "Safety and Health Provisions", 7-1.08 "Public Convenience", 7-1.09 "Public Safety", and 12-3.04 "Portable Delineators" of the Standard Specifications, the 2006 California Manual of Uniform Traffic Control Devices (MUTCD), the Section of these contract documents entitled "Insurance - Hold Harmless", and these Special Provisions.

All existing traffic control signs and street name signs shall be maintained in visible locations as directed by the Engineer.

No detours will be provided, unless specifically allowed herein. The Contractor will be required to conduct his operations in such a manner that traffic will be permitted to pass through the work area with as little delay as possible.

All warning lights, signs, flares, barricades and other facilities for the sole convenience and direction of public traffic shall be furnished and maintained by the Contractor. All traffic control devices shall conform to and be placed in accordance with the 2006 California Manual of Uniform Traffic Control Devices (MUTCD), the corresponding California Supplement, and subsequent modifications as adopted by the State of California Department of Transportation.

All construction signs shall be either covered or removed when not required by the nature of the work or if no present hazard to the motorist exists.

The Contractor shall notify the appropriate regional notification center for operators of subsurface installations at least 2 working days, but not more than 14 calendar days, prior to commencing excavation for construction area sign posts. The regional notification centers include, but not limited to, the following:

Notification Center	Telephone Number
Underground Service Alert- Southern California (USA)	1-800-422-4133 1-800-227-2600 or 811

Excavations required to install construction area signs shall be performed by hand methods without the use of power equipment, except that power equipment may be used if it is determined there are no utility facilities in the area of the proposed post holes.

No payment for extra work will be allowed for work performed as specified in Section 12-2.02 (Flagging Costs) of the Standard Specifications. Flagging costs will be borne entirely by the Contractor.

Dust control shall conform to the provision of Section 10 of the Standard Specifications except that no extra work will be allowed when the Engineer orders the application of water for the purpose of controlling dust caused by public traffic as provided for in the last paragraph of Section 10.

The Contractor shall be responsible to distribute an information letter pertaining to the planned work to all affected residences and businesses, at least one week prior to commencing work adjacent to those residences and businesses. It shall be the responsibility of the Contractor to design the information letter, obtain design approval from the Engineer, print sufficient copies, and distribute the letter. The Transportation Department logo shall be included on the letter. A computer file of the logo may be obtained from the Engineer in .WPG, .DXF, .DGN or .DWG format. The letter shall be similar to the sample provided by the Engineer, and shall include a project description, the scope of work, the anticipated construction schedule, and other information as appropriate.

The Contractor shall post temporary no parking signs on affected streets 24 hours prior to work on those streets. The temporary no parking signs shall state the anticipated dates and hours of work on those streets.

Payment:

Full compensation, except as otherwise provided herein, for conforming to the requirements of this article, including furnishing, installing and maintaining all traffic control devices shown on the construction staging and traffic control plans, including construction area signs, channelizers, portable changeable message signs, temporary pavement markers, temporary traffic stripes, shall be considered as included in the contract lump sum price paid for Traffic Control System, and no additional compensation will be allowed therefor.

PROGRESS PAYMENTS:

For the purpose of making partial payments pursuant to Section 9-1.06, "Partial Payments" of the Standard Specifications, the amount set forth for the contract item of work hereinafter listed shall be deemed to be maximum total value of said contract item of work which will be recognized for progress payment purposes:

Clearing and Grubbing - \$ 30,000.00
Mobilization - \$ 20,000.00
Develop Water Supply - \$ 5,000.00

After acceptance of the contract pursuant to Section 7-1.17, ``Acceptance of Contract'' of the Standard Specifications, the amount, if any, payable for a contract item of work in excess of the maximum value for progress payment purposes herein above listed for said item, will be included for payment in the first estimate made after acceptance of the contract.

CLEARING AND GRUBBING:

Clearing and grubbing (including the removal of trees/shrubs, required grading within right-of-way for drainage and matching existing grades, installation of irrigation sleeves for future use, and removal and/or relocation/resetting of all private facilities/improvements from the public right-of-way and on private property including landscaping/irrigation, mailboxes, play sets, concrete/AC walks, AC Berm, hardscape, and driveways, etc.) shall conform to the provisions in Section 16 of the Standard Specifications.

Attention is directed to the Federal Migratory Bird Treaty Act (15 USC 703-711) 50 CFR Part 21 and 50 CFR Part 10, and the California Department of Fish and Game Code Sections 3503, 3513 and 3800, that protect migratory birds, their occupied nests, and their eggs from disturbance or destruction.

Ground disturbance, tree, shrub and/or vegetation removal that occurs between February 1st and September 1st will not commence until a preconstruction survey for nesting birds has verified that no active nests have been located or the Engineer has approved the beginning of work. The County will perform the survey. If an active nest is located, construction within 500 feet of the nest must be avoided until the nest has been vacated and the young are independent of their parents.

The Contractor shall use exclusion techniques directed by the Engineer to prevent migratory birds from nesting in trees within the project limits.

If evidence of bird nesting is discovered, the Contractor shall not disturb the nesting birds or nests until the birds have naturally left the nests. If evidence of migratory bird nesting is discovered after beginning work, the Contractor shall immediately stop work within 500 feet of the nests and notify the Engineer. Work shall not resume until the Engineer provides a written notification that work may begin at or adjacent areas of the discovered bird nest locations.

Attention is directed to Section 8-1.05, "Temporary Suspension of Work" of the Standard Specifications.

Payment:

Full compensation, except as otherwise provided herein, for conforming to the requirements of this article shall be paid for on a lump sum basis and no additional compensation will be allowed therefor.

MOBILIZATION:

Mobilization shall conform to the provisions in Section 11, "Mobilization" of the Standard Specifications.

Payment:

Full compensation, except as otherwise provided herein, for conforming to the requirements of this article shall be paid for on a lump sum basis and no additional compensation will be allowed therefor.

DEVELOP WATER SUPPLY:

Develop water supply shall conform to the provisions of Section 17 of the Standard Specifications and these Special Provisions.

Attention is directed to the requirements of Section 10, "Dust Control".

Payment:

Full compensation for developing water supply and furnishing watering equipment shall be considered as included in the lump

sum price paid for develop water supply and no additional compensation will be allowed therefor.

WATER POLLUTION CONTROL (WHITEWATER - RISK LEVEL 1):

Throughout the term of this contract, the total land disturbance area of this project is qualified for an Erosivity Waiver. The Contractor shall comply the Area-Wide Municipal Stormwater Permit NPDES No. CAS617002, hereafter referred to in this section as the ``Municipal Permit'', issued by the California Regional Water Quality Control Board (CRWQCB) - Whitewater Region. This permit regulates both stormwater and non-stormwater discharges associated with Contractor's construction activities. A copy of the Permit may be obtained at the office of the County of Riverside Transportation Department, 14th Street Transportation Annex, 3525 14th Street, Riverside, California. (951) 955-6780, or may be obtained on the internet at: <http://www.waterboards.ca.gov/coloradoriver/>

The Contractor shall comply with the requirements of the Municipal Permit, and all applicable federal, state and local laws, ordinances, statues, rules, and regulations

Contractor's Water Pollution Control Program (WPCP) Preparation Manual shall be prepared by a Qualified SWPPP Developer in accordance with Section 3, ``Preparing a Water Pollution Control Program (WPCP)'', of the Caltrans Stormwater Pollution Prevention Plan (SWPPP) and Water Pollution Control Program (WPCP)

Preparation Manual (March 2007), which is available as a free download from:

<http://www.dot.ca.gov/hq/construc/stormwater/manuals.htm>

WATER POLLUTION CONTROL MEASURES

A. Work having the potential to cause water pollution shall not commence until the Contractor's WPCP has been reviewed and approved by the Engineer. The Engineer's review and approval of the Contractor's WPCP shall not waive any contractual requirements and shall not relieve the Contractor from achieving and maintaining compliance with all federal, state, and local laws, ordinances, statues, rules, and regulations. A copy of Contractor's WPCP shall be maintained onsite. When the WPCP or access to the construction site is requested by a representative of a federal, state, or local regulatory agency, Contractor shall make the WPCP available and Contractor shall immediately contact the Engineer. Requests from the public for the Contractor's WPCP shall be directed to the Engineer.

B. Contractor's WPCP shall describe the Contractor's plan for managing runoff during each construction phase. Contractor's WPCP shall describe the Best Management Practices (BMPs) that will be implemented to control erosion, sediment, tracking, construction materials, construction wastes, and non-stormwater flows. BMP details shall be based upon California Stormwater Quality

Association's 2009 California Stormwater Quality BMP Handbook Portal or the Caltrans Construction Site BMP Manual

(<http://www.dot.ca.gov/hq/construc/stormwater/manuals.htm>)

Contractor's WPCP shall describe installation, operation, inspection, maintenance, and monitoring activities that will be implemented for compliance with the Construction General Permit and all applicable federal, state, and local laws, ordinances, statutes, rules, and regulations related to the protection of water quality.

- C. The Contractor's WPCP preparer shall have been trained to prepare WPCPs or SWPPPs and shall have previous experience with preparing SWPPP or WPCP requirements on a previous project.

The Contractor shall designate a Water Pollution Control Manager that shall have been trained to implement WPCP or SWPPP requirements. Contractor's Water Pollution Control Manager shall:

1. Be responsible for all water pollution control work.
2. Be the Engineer's primary contact for all water pollution control work.
3. Have the authority to mobilize resources (crews, supplies, equipment, etc.) to make immediate repairs of water pollution control measures or to supplement

water pollution control measures to maintain compliance with all federal, state, and local laws, ordinances, and regulations related to the protection of water quality, including the General Permit for Stormwater Discharges Associated with Construction and Land Disturbance Activities.

The WPCP shall contain all required and applicable certifications and evidence of training for the Water Pollution Control Manager, SWPPP Developer, and all other employees working on the project receiving formal training or certification.

D. Water Pollution Control Training: Contractor shall provide water pollution control training to Contractor's employees and subcontractors prior to their performing work on the work site. The water pollution control training shall be appropriate to the employee or subcontractor function and area of responsibility and shall address (as applicable):

1. Erosion Control (water and wind)
2. Sediment Control
3. Tracking Control
4. Materials & Waste Management
5. Non-Stormwater Discharge Management

E. Monitoring and Reporting: Observations and inspections conducted by the Contractor's Water Pollution Control Manager shall be documented on the Construction Site

Inspection Checklist included in Contractor's WPCP. A copy of each completed Construction Site Inspection Checklist shall be submitted to the Engineer within 24 hours of conducting the inspection.

General Requirements:

In the event the County incurs any Administrative Civil Liability (fine) imposed by the CRWQCB - Whitewater Region, as a result of Contractor's failure to fully implement the provisions of "Stormwater and Non-Stormwater Pollution Control", the Engineer, may, in the exercise of his sole judgment and discretion, withhold from payments otherwise due Contractor a sufficient amount to cover the Administrative Civil Liability including County staff time, legal counsel, consultant support costs and all other associated cost.

The Contractor shall be responsible for all costs and for any liability imposed by law as a result of the Contractor's failure to comply with the requirements set forth in "Water Pollution Control", including but not limited to, compliance with the applicable provisions of the Caltrans Handbooks, Construction General Permit, Federal, State, and local regulations. For the purpose of this paragraph, costs and liabilities include, but not limited to, fines, penalties, damages, and costs associated with defending against enforcement actions whether taken against the County or the Contractor, including those levied under the Federal Clean Water Act and the State Porter-Cologne Water Quality Act.

Within fifteen (15) working days after the award of the contract, the Contractor shall submit two (2) copies of the WPCP to the Engineer for review and approval. The Contractor shall allow ten (10) working days for the Engineer to review the WPCP. If revisions are required as determined by the Engineer, the Contractor shall revise and resubmit the WPCP within three (3) working days of receipt of the Engineer's comments and shall allow ten (10) working days for the Engineer to review the revisions. The Contractor shall submit four (4) copies of the approved WPCP to the Engineer prior to notice to proceed. The Contractor must have an approved WPCP prior to the notice to proceed. The Engineer may provide a letter of conditional approval of the Contractor's WPCP while minor revisions are made and may allow the Contractor to begin only those certain construction activities identified in the letter of conditional approval. In no case will the conditional approval extend beyond twenty-one (21) calendar days. The Engineer may suspend construction operations until the Contractor submits a revised WPCP that is reviewed and approved by the Engineer.

Unless otherwise directed by the Engineer or specified in these Special Provisions, the Contractor's responsibility for WPCP implementation shall continue throughout any temporary suspension of work ordered in accordance with Section 8-1.05, "Temporary Suspension of the Work", of the Standard Specifications. The Engineer may withhold progress payments or order the suspension of construction operations without an extension of the contract time, if the Contractor fails to comply with the requirements of "Water Pollution Control" as determined by the Engineer.

All BMP repairs shall be implemented by the Contractor within 72 hrs. All BMP repairs shall also be implemented by the Contractor prior to a qualifying storm event, as defined in the Construction General Permit. The Contractor shall be responsible for bi-weekly, pre and post storm, and quarterly (Jan-Mar, Apr-Jun, Jul-Sept, and Oct-Dec) non-stormwater inspections. At the direction, the Contractor shall be responsible for providing any information for annual reporting purposes in electronic format, including inspection reports, photos, NOI, etc.

Payment for Water Pollution Control shall be on a lump sum basis and shall include full compensation for the work performed, including, developing, preparing, revising, obtaining approval of, and amending the WPCP, implementing, installing, constructing, operating, maintaining, and removing and disposing of temporary BMPs, performing the observations, inspections, sampling, analysis, reporting, and street sweeping, and as specified in the Caltrans Handbooks, Municipal Permit and these Special Provisions, and as directed by the Engineer.

STREET SWEEPING:

GENERAL

Summary

This work includes street sweeping.

The SWPPP/MP shall describe and include the use of street sweeping as a Water Pollution Control practice for sediment control and tracking control. Street sweeping shall also conform to all applicable AQMD requirements.

Submittals

At least 5 working days before starting clearing and grubbing, earthwork, or other activities with the potential for tracking sediment or debris, submit:

- A. The number of street sweepers that will be used as described in the SWPPP/MP.
- B. Type of sweeper technology (or technologies).

Quality Control and Assurance

Retain the following records related to street sweeping and submit weekly to Engineer:

- A. Tracking Inspection Log
- B. Sweeping times and locations.
- C. Quantity of sweeping waste disposal.

CONSTRUCTION

Street Sweepers

Sweepers must use one of these technologies:

- A. Mechanical sweeper followed by a vacuum-assisted sweeper.
- B. Vacuum-assisted dry (waterless) sweeper.
- C. Regenerative-air sweeper.

Operation

Street sweeping shall be conducted at:

- A. Paved roads at job site entrance and exit locations.
- B. Paved areas within the job site that flow to storm drains or water bodies.

Street sweeping shall be conducted, and sweeper(s) shall be available to operate at all times, for the following:

- A. During clearing and grubbing activities.
- B. During earthwork activities.
- C. During trenching activities.
- D. During roadway structural section activities.
- E. When vehicles are entering and leaving the job site.
- F. After soil disturbing activities.
- G. After observing offsite tracking of material.

Contractor's Water Pollution Control Manager shall inspect adjacent paved areas at job site entrances and exits and paved roadways within the job site on a minimum daily basis, and more frequently when activities that require street sweeping are being performed. Contractor's Water Pollution Control Manager shall maintain a "Tracking Inspection Log." Street sweeping shall be conducted:

- A. Within 1 hour, if sediment or debris is observed on paved areas or paved roadways.

At least one sweeper, in good working order, must be on the job site at all times when sweeping work may be required.

Perform street sweeping to minimize dust. If dust generation is excessive or sediment pickup is ineffective, water may be used but shall be contained, collected (e.g. vacuum), and properly disposed.

Material collected during street sweeping must be removed and disposed of under Section 7-1.13, "Disposal of Material Outside the Highway Right of Way" of the Standard Specifications.

Full compensation to conform with the requirements of this section shall be considered as included the contract lump sum price paid for Water Pollution Control including furnishing all labor, materials, tools, equipment, and incidentals and for doing all the work involved in street sweeping, including disposal of collected material, as shown on the plans, as specified in the Standard Specifications, these Special Provisions, and as

directed by the Engineer. Therefore, no additional compensation will be allowed for street sweeping.

ROADWAY EXCAVATION:

Roadway excavation shall conform to the provisions of Section 19 of the Standard Specifications and these Special Provisions.

At road connections and at limits of asphalt paving, existing pavement shall be header cut as shown on the plans or as directed by the Engineer. Full compensation for furnishing all labor, tools and doing all the work necessary including grinding and sawcutting, shall be considered as included in the contract prices paid per ton for the various asphalt concrete items and no additional compensation will be allowed therefor.

Existing pavement including any base material shall be cut back to neat lines and removed as shown on the plans or as directed by the Engineer. Excess material will become the property of the Contractor and will be disposed of as provided in Section 7-1.13 of the Standard Specifications.

Pavement and base material removal will be considered as roadway excavation for payment purposes.

Relative Compaction:

Whenever relative compaction is specified to be determined by Test Method No. Calif. 216, the in-place density may be determined by Test Method No. Calif. 231. The in-place density required by Test Method No. Calif. 312 may be determined by Test Method No. 231. The wet weight or dry weight basis and English Units of Measurement may be used at the option of the County's Materials Engineer.

Payment:

The unit bid price paid per cubic yard for Roadway Excavation shall include full compensation for furnishing all labor, materials, tools, equipment, and incidentals, and for doing all work involved including compaction and the removal of asphalt concrete berm as directed by the Engineer and no additional compensation will be allowed therefor. No adjustment in the bid

price per cubic yard for overages or underages from the stated quantity will be allowed.

FINISHING ROADWAY:

Finishing roadway shall conform to Section 22 of the Standard Specifications.

Payment:

Full compensation, except as otherwise provided herein, for conforming to the requirements of this article shall be considered as included in the contract bid prices paid for the various items of work, and no additional compensation will be allowed therefor.

AGGREGATE BASE:

Aggregate base shall be Class 2 and shall conform to the provisions in Section 26, "Aggregate Bases" of the Standard Specifications and these Special Provisions and shall meet the gradation requirements for 3/4 inch maximum.

The first paragraph of Section 26-1.02A, "Class 2 Aggregate Base" shall be modified to read:

Aggregate for Class 2 aggregate base shall be free from organic matter and other deleterious matter, and shall be of such nature that it can be compacted readily under watering and rolling to form a firm and stable base. Aggregate may consist of broken and crushed asphalt concrete or Portland cement concrete and may contain crushed aggregate base or other rock materials. The material may contain no more than 3 percent brick by weight as determined by California Test Method 202 as modified: Brick material retained on a No.4 sieve shall be identified visually and separated manually. Brick quantification shall be based on total weight of dry sample. Also, material retained on the 4.75 mm (No.4) sieve shall contain no more than 15 percent of particles (gravel) that have no more than one fractured face.

The Quality Requirements contained in Section 26-1.02A shall be modified to read:

QUALITY REQUIREMENTS

Test	Contract Compliance
Resistance (R-Value)	
Virgin Rock	78 Minimum
Crushed Miscellaneous	80 Minimum
Sand Equivalent	35 Minimum
Durability Index	35 Minimum
Percentage Wear	
100 Revolutions	15 Maximum
500 Revolutions	52 Maximum

Payment:

Quantities of Aggregate Base will be paid for at the contract unit price per cubic yard and in accordance with the provisions of Sections 26-1.06 and 26-1.07 of the Standard Specifications, and will include the base requirements under all proposed PCC concrete and AC pavement improvements. No adjustment in the bid price per cubic yard for overages or underages from the stated quantity will be allowed.

HOT MIX ASPHALT:

The asphalt concrete shall be Type "A" and shall conform to the requirements of Section 39 of the Standard Specifications and the following:

Aggregate grading shall be three-quarter inch (3/4") maximum, medium for base course and three-quarter inch (3/4") maximum, medium for the final course. One-half inch (1/2") maximum, medium for the final course shall be used if shown on the plans or as directed by the Engineer.

The asphalt lift thickness table, as shown in Section 39-6.01, "General Requirements" of the Standard Specifications, is revised as follows:

Total Thickness Shown on Plans	Minimum No. of Layers	Top Layer Thickness (foot)		Next Lower Layer Thickness (foot)		All Other Lower Layer Thickness (foot)	
		Min.	Max.	Min.	Max.	Min.	Max.
0.24-foot or less ^a	1	-	-	-	-	-	-
0.25-foot	2 ^b	0.12	0.13	0.12	0.13	-	-
0.26 - 0.46 foot	2	0.12	0.21	0.14	0.25	-	-
0.47-foot or more	3 or more	0.15	0.21	0.15	0.25	0.17	0.25

Footnotes to asphalt thickness table are revised as follows:

- a. No Change.
- b. One layer of 0.25 foot thick may be placed as approved by the Engineer. When the Traffic Index specified is 5.5 or below, two layers shall be placed.

Asphalts:

Asphalt shall conform to the provisions in this Section, "Asphalts". Section 92, "Asphalts" of the Standard Specifications shall not apply.

Asphalt shall consist of refined petroleum or a mixture of refined liquid asphalt and refined solid asphalt, prepared from crude petroleum. Asphalt shall be:

1. Free from residues caused by the artificial distillation of coal, coal tar, or paraffin;
2. Free from water;
3. Homogeneous.

General:

The Contractor shall furnish asphalt in conformance with the State of California Department of transportation's Certification Program for Suppliers of Asphalt". The Department maintains the program requirements, procedures, and a list of approved suppliers at <http://www.dot.ca.gov/hq/esc/Translab/fpmcoc.htm>.

The Contractor shall ensure the safe transportation, storage, use, and disposal of asphalt.

The Contractor shall prevent the formation of carbonized particles caused by overheating asphalt during manufacturing or construction.

Grade:

Performance graded (PG) asphalt binder shall conform to the following:

Property	AASHTO Test Method	Specification Grade		
		PG 64-10	PG 64-16	PG 70-10
Original Binder				
Flash Point, Minimum °C	T48	230	230	230
Solubility, Minimum % ^b	T44	99	99	99
Viscosity at 135 °C, Maximum, Pa's	T316	3.0	3.0	3.0
Dynamic Shear, Test Temp. at 10 rad/s, °C Minimum G*/sin(delta), kPa	T315	64 1.00	64 1.00	70 1.00
RTFO Test ^e , Mass Loss, Maximum, %	T240	1.00	1.00	1.00
RTFO Test Aged Binder				
Dynamic Shear, Test Temp. at 10 rad/s, °C Minimum G*/sin(delta), kPa	T315	64 2.20	64 2.20	70 2.20
Ductility at 25 °C Minimum, cm	T51	75	75	75
PAV ^f Aging, Temperature, °C	R28	100	100	110
RTFO Test and PAV Aged Binder				
Dynamic Shear, Test Temp. at 10 rad/s, °C Maximum G*/sin(delta), kPa	T315	31 ^d 5000	28 ^d 5000	34 ^d 5000
Creep Stiffness, Test Temperature, °C Maximum S-value, Mpa Minimum M-value	T313	0 300 0.300	-6 300 0.300	0 300 0.300

Notes:

- a. Not used.
- b. The Engineer will waive this specification if the supplier is a Quality Supplier as defined by Department's "Certification Program for Suppliers of Asphalt".
- c. The Engineer will waive this specification if the supplier certifies the asphalt binder can be adequately pumped and mixed at temperatures meeting applicable safety standards.
- d. Test the sample at 3 °C higher if it fails at the specified test temperature. G*/sin(delta) shall remain 5000 kPa maximum.
- e. "RTFO Test" means the asphaltic residue obtained using the Rolling Thin Film Oven Test, AASHTO Test Method T240 or ASTM Designation: D2827.
- f. "PAV" means Pressurized Aging Vessel.

Performance graded polymer modified asphalt binder (PG Polymer Modified) is:

Performance Graded Polymer Modified Asphalt Binder ^a

Property	AASHTO Test Method	Specification Grade		
		PG 58-34 PM	PG 64-28 PM	PG 76-22 PM
Original Binder				
Flash Point, Minimum °C	T 48	230	230	230
Solubility, Minimum % ^b	T 44 ^c	98.5	98.5	98.5
Viscosity at 135°C, ^d Maximum, Pa·s	T 316	3.0	3.0	3.0
Dynamic Shear, Test Temp. at 10 rad/s, °C Minimum G*/sin(delta), kPa	T 315	58 1.00	64 1.00	76 1.00
RTFO Test , Mass Loss, Maximum, %	T 240	1.00	1.00	1.00
RTFO Test Aged Binder				
Dynamic Shear, Test Temp. at 10 rad/s, °C Minimum G*/sin(delta), kPa	T 315	58 2.20	64 2.20	76 2.20
Dynamic Shear, Test Temp. at 10 rad/s, °C Maximum (delta), %	T 315	Note e 80	Note e 80	Note e 80
Elastic Recovery ^f , Test Temp., °C Minimum recovery, %	T 301	25 75	25 75	25 65
PAV ^g Aging, Temperature, °C	R 28	100	100	110
RTFO Test and PAV Aged Binder				
Dynamic Shear, Test Temp. at 10 rad/s, °C Maximum G*sin(delta), kPa	T 315	16 5000	22 5000	31 5000
Creep Stiffness, Test Temperature, °C Maximum S-value, MPa Minimum M-value	T 313	-24 300 0.300	-18 300 0.300	-12 300 0.300

Notes:

- a. Do not modify PG Polymer Modifier using acid modification.
- b. The Engineer waives this specification if the supplier is a Quality Supplier as defined by the Department's "Certification Program for Suppliers of Asphalt".
- c. The Department allows ASTM D5546 instead of AASHTO T44.
- d. The Engineer waives this specification if the supplier certifies the asphalt binder can be adequately pumped and mixed at temperatures meeting applicable safety standards.
- e. Test temperature is the temperature at which G*/sin(delta) is 2.2 kPa. A graph of log G*/sin(delta) plotted against temperature may be used to determine the test temperature when G*/sin(delta) is 2.2 Kpa. A graph of (delta) versus temperature may be used to determine delta at the temperature when G*/sin(delta) is 2.2 kPa. The Engineer also accepts direct measurement of (delta) at the temperature when G*/sin(delta) is 2.2 kPa.
- f. Test without a force ductility clamp may be performed.
- g. "PAV" means Pressurized Aging Vessel.

Sampling:

The Contractor shall provide a sampling device in the asphalt feed line connecting the plant storage tanks to the asphalt weighing system or spray bar. The sampling device shall be accessible between 24 and 30 inches above the platform. The Contractor shall provide a receptacle for flushing the sampling device.

The sampling device shall include a valve:

1. With a diameter between 1/2 and 3/4 inches;
2. Manufactured in a manner that a one-quart sample may be taken slowly at any time during plant operations;
3. Maintained in good condition.

The Contractor shall replace failed valves.

In the presence of the Engineer, the Contractor shall take 2 one-quart samples per operating day. The Contractor shall provide round friction top containers with one-quart capacity for storing samples.

Applying Asphalt:

Unless otherwise specified, the Contractor shall heat and apply asphalt in conformance with the provisions in Section 93, ``Liquid Asphalts'' of the Standard Specifications.

Section 39-2.01, ``Asphalts'' is replaced in its entirety with the followings:

Asphalt binder to be mixed with aggregate shall conform to the provisions in ``Asphalts'' of these Special Provisions.

The grade of asphalt binder shall be 70-10 (Desert).

Liquid asphalt for prime coat shall conform to the provisions in Section 93, ``Liquid Asphalts'' of the Standard Specifications and shall be Grade 64-10 unless otherwise designated by the contract item or otherwise specified in the Special Provisions.

Asphaltic emulsion for paint binder (tack coat) shall conform to the provisions in Section 94, "Asphaltic Emulsion" of the Standard Specifications for the rapid-setting or slow-setting type and grade approved by the Engineer.

Section 39-3.01B (1) shall be amended to include:

Aggregate of the 3/4 inch or 1/2 inch maximum size and aggregate for asphalt concrete base shall be separated into 3 or more sizes and each size shall be stored in separate bins. If 3 sizes are used, one bin shall contain that portion of the material which will pass the maximum size specified and be retained on a 3/8 inch sieve; one bin shall contain that portion of the material which will pass a 3/8 inch sieve and be retained on a No. 8 sieve; and one bin shall contain that portion of the material which will pass a No. 8 sieve.

Aggregate of 3/8 inch maximum size shall be separated into 2 sizes and each size shall be stored in separate bins. One bin shall contain that portion of the material which will pass the maximum size specified and be retained on a No. 8 sieve and one bin shall contain that portion of the material which will pass a No. 8 sieve.

The bin containing the fine material shall not contain more than 15 percent of material retained on the No. 8 sieve. The material in any of the other bins shall not contain more than 15 percent of material passing a No. 8 sieve. Failure to comply with this requirement shall be corrected immediately, and the material in the bins not meeting these requirements shall be re-screened or wasted.

All asphalt concrete for this project shall be supplied from one source unless approved by the Engineer. Said source shall be listed on the Contractors Source of Materials List as required in Section 6 of the Standard Specifications.

Asphaltic emulsion shall be furnished and applied as provided in Section 39-4.02.

The Contractor shall adjust to finish grade any valve covers encountered within the project limits, as required, for those utility valves that are provided with slip cans and are

adjustable without the replacement of parts or the removal of concrete collars. In cases where the owning utility company insists upon upgrades in the standards, or when additional parts or the removal of concrete collars are required for the adjustment, said adjustment will be the responsibility of the owning utility company.

For public safety, traffic shall not be allowed on temporary or permanent pavement until all manholes are either adjusted to grade or otherwise protected, as approved by the Engineer. The Contractor shall adjust to grade manholes and valves when and as necessary for the protection of the traveling public during construction, and shall coordinate all work on said facilities with the owning utility companies. This requirement is intended for traffic that is to be allowed on temporary surfaces during the course of construction. Final adjustment to grade will be the responsibility of the owning utility company, except as provided herein.

Said work shall be performed in accordance with Section 15-2.05A, ``Frames, Covers, Grates, and Manholes'' of the Standard Specifications. Full compensation for adjustment of valve covers, including initial lowering of valves and manholes when required, shall be considered as included in the contract price paid for asphalt concrete.

In addition to the provisions in Section 39-5.01, ``Spreading Equipment'' of the Standard Specifications, asphalt paving equipment shall be equipped with automatic screed controls and a sensing device or devices.

When placing asphalt concrete to the lines and grades established by the Engineer, the automatic controls shall control the longitudinal grade and transverse slope of the screed. Grade and slope references shall be furnished, installed, and maintained by the Contractor. Should the Contractor elect to use a ski device, the minimum length of the ski device shall be 30 feet. The ski device shall be a rigid one piece unit and the entire length shall be utilized in activating the sensor.

When placing the initial mat of asphalt concrete on existing pavement, the end of the screed nearest the centerline shall be controlled by a sensor activated by a ski device not less than 30 feet. The end of the screed farthest from centerline shall be controlled by an automatic transverse slope device set to

reproduce the cross slope designated by the Engineer, by a sensor activated by a similar ski device or as directed by the Engineer.

When paving contiguously with previously placed mats, the end of the screed adjacent to the previously placed mat shall be controlled by a sensor that responds to the grade of the previously placed mat and will reproduce the grade in the new mat within a 0.12 inch tolerance. The end of the screed farthest from the previously placed mat shall be controlled in the same way it was controlled when placing the initial mat.

Should the methods and equipment furnished by the Contractor fail to produce a layer of asphalt concrete conforming to the provisions, including straightedge tolerance, of Section 39-6.03, ``Compacting'' of the Standard Specifications or elsewhere in these Special Provisions, the paving operations shall be discontinued and the Contractor shall modify the equipment or methods, or furnish substitute equipment.

Should the automatic screed controls fail to operate properly during a day's work, the Contractor may manually control the spreading equipment for the remainder of that day. However, the equipment shall be corrected or replaced with alternative automatically controlled equipment conforming to the provisions in this section before starting another day's work.

General Criteria For Profiling:

In addition to the straightedge provisions in Section 39-6.03, ``Compacting'' of the Standard Specifications, asphalt concrete pavement shall conform to the surface tolerances specified herein.

The uppermost layer of asphalt concrete surfacing shall be profiled in the presence of the Engineer using a California Profilograph or equivalent in conformance with California Test 526 and as specified in these Special Provisions.

The California Profilograph or equivalent will not be required for the following areas of the pavement surface but shall conform to the straightedge requirements in Section 39-6.03, ``Compacting'' of the Standard Specifications:

1. Pavement with a total thickness less than 0.24 foot;

2. Pavement on horizontal curves with a centerline curve radius of less than 1,000 feet and the pavement within the superelevation transition on those curves;
3. Pavement placed in a single lift when required by the Special Provisions;
4. Pavement with extensive grade or cross slope correction which does not receive advance leveling operations in conformance with the provisions in Section 39-6.02, "Spreading" of the Standard Specifications;
5. Pavement for ramps and connectors with steep grades and high rates of superelevation, as determined by the Engineer;
6. Shoulders and miscellaneous areas.

The Contractor shall conform to California Test 526, except a zero (null) blanking band shall be used for determining the Profile Index. Prior to beginning profiles, the profilograph shall be calibrated in the presence of the Engineer. Two profiles shall be obtained within each traffic lane, 3 feet from and parallel with the edges of the lane.

Pavements profiled shall conform to the following Profile Index requirements:

1. Pavement on tangent alignment and pavement on horizontal curves having a centerline curve radius of 2,000 feet or more shall have a Profile Index of 0.16 foot or less for each 330 feet section profiled;
2. Pavement on horizontal curves having a centerline curve radius of 1,000 feet or more but less than 2,000 feet, including the pavement within the superelevation transition of these curves, shall have a Profile Index of 0.32 foot or less for each 330 feet section profile;
3. Pavement within any 330 feet section, containing high point areas with deviations in excess of 0.025 foot in a length of 25 feet or less, when tested in conformance with the requirements in California Test 526, shall be corrected by the Contractor regardless of the Profile Index.

The Contractor shall complete initial runs of the profilograph prior to opening the pavement to public traffic. If initial profiles can not be made prior to opening the pavement to public traffic, the initial runs of the profilograph shall be made the next day that traffic control is permitted for the area to be profiled.

Areas of the top surface of the uppermost layer of asphalt concrete pavement that do not meet the specified surface tolerances shall be brought within tolerance by abrasive grinding.

Abrasive grinding shall be performed to reduce individual deviations in excess of 0.025 foot, and to reduce the Profile Index of the pavement to be within the specified tolerance. Areas which have been subjected to abrasive grinding shall receive a seal coat. Deviations in excess of 0.025 foot which cannot be brought into specified tolerance by abrasive grinding shall be corrected by either (1) removal and replacement or (2) placing an overlay of asphalt concrete. The corrective method for each area shall be selected by the Contractor and shall be approved by the Engineer prior to beginning the corrective work. Replacement or overlay pavement not meeting the specified tolerances shall be corrected by the methods specified above. Corrective work shall be at the Contractor's expense. The Contractor shall run profilograms on the areas that have received abrasive grinding or corrective work until the final profilograms indicate the Profile Index of the area is within the specified tolerance.

When abrasive grinding is used to bring the top surface of the uppermost layer of asphalt concrete surfacing within the specified surface tolerances, additional abrasive grinding shall be performed as necessary to extend the area ground in each lateral direction so that the lateral limits of grinding are at a constant offset from, and parallel with, the nearest lane line or pavement edge, and in each longitudinal direction so that the grinding begins and ends at lines normal to the pavement centerline, within a ground area. Ground areas shall be neat rectangular areas of uniform surface appearance.

The original of the final profilograms that indicate the pavement surface is within the Profile Index specified shall become the property of the County and shall be delivered to the Engineer prior to acceptance of the contract.

Payment:

Asphalt Concrete for road pavement and driveway tie-ins will be paid for at a unit price per ton as a combined item, including mineral aggregate and asphalt binder in place on the roadbed.

The contract bid price paid per ton for Hot mix Asphalt shall include full compensation for furnishing all labor, tools, materials, equipment, and incidentals, and for doing all the work involved including the furnishing and applying asphaltic emulsion (paint binder), matching existing pavement with 2-foot wide grinding/overlay and no additional compensation will be allowed therefor.

COMPENSATION ADJUSTMENTS FOR PRICE INDEX FLUCTUATIONS:

The provisions of this section shall apply only to the following contract items:

ITEM CODE	ITEM
390130	Hot Mix Asphalt

The compensation payable for asphalt concrete will be increased or decreased in conformance with the provisions of this section for paving asphalt price fluctuations exceeding 10 percent (Iu/Ib is greater than 1.10 or less than 0.90) which occur during performance of the work.

The adjustment in compensation will be determined in conformance with the following formulae when the item of asphalt concrete and asphalt rubber hot mix are included in a monthly estimate:

A. Total monthly adjustment = AQ

B. For an increase in paving asphalt price index exceeding 10 percent:

$$A = 0.90 (Iu/Ib - 1.10) Ib$$

C. For a decrease in paving asphalt price index exceeding 10 percent:

$$A = 0.90 (Iu/Ib - 0.90) Ib$$

D. Where:

A = Adjustment in dollars per ton of paving asphalt used to produce asphalt rubber hot mix rounded to the nearest \$0.01.

Iu = The California Statewide Paving Asphalt Price Index which is in effect on the first business day of the month within the pay period in which the quantity subject to adjustment was included in the estimate.

Ib = The California Statewide Paving Asphalt Price Index for the month in which the bid opening for the project occurred.

Q = Quantity in tons of paving asphalt that was used in producing the quantity of asphalt concrete shown under "This Estimate" on the monthly estimate using the amount of asphalt determined by the Engineer.

The adjustment in compensation will also be subject to the following:

- A. The compensation adjustments provided herein will be shown separately on payment estimates. The Contractor shall be liable to the State for decreased compensation adjustments and the Department may deduct the amount thereof from moneys due or that may become due the Contractor.
- B. Compensation adjustments made under this section will be taken into account in making adjustments in conformance with the provisions in Section 4-1.03B, "Increased or Decreased Quantities" of the Standard Specifications.
- C. In the event of an overrun of contract time, adjustment in compensation for paving asphalt included in estimates during the overrun period will be determined using the California Statewide Paving Asphalt Price Index in effect on the first business day of the month within the pay period in which the overrun began.

The California Statewide Paving Asphalt Price Index is determined each month on the first business day of the month by the Department using the median of posted prices in effect as posted

by Chevron, Mobil, and Unocal for the Buena Vista, Huntington Beach, Kern River, Long Beach, Midway Sunset, and Wilmington fields.

In the event that the companies discontinue posting their prices for a field, the Department will determine an index from the remaining posted prices. The Department reserves the right to include in the index determination the posted prices of additional fields.

SUBGRADE ENHANCEMENT TREATMENT:

The Contractor is hereby notified that shallow groundwater and/or yielding of the upper soils will be encountered within the project site area.

In addressing groundwater problems, including yielding or pumping of the upper soils during construction, methods of subgrade stabilization treatment and/or mitigation measures will include the following:

- a. Overexcavate the soil an additional 12 inches below the finished subgrade or as directed by the Engineer.
- b. Place the first layer of geogrid directly on the soft and yielding soil.
- c. Spread aggregate base materials in layers using a track-type dozer up to the original finished subgrade. The number of layers or lifts will depend on the operating weight of the dozer as specified herein.
- d. Place the second layer of geogrid prior to the required aggregate base and asphalt concrete layers.

Installation of the geogrid shall be in accordance with the manufacturer's recommendation except overlaps (longitudinal and transverse) shall be 36 inches. The geogrid shall be placed directly on the soft soil and on the first layer of aggregate base surface.

Contractor shall utilize small to medium track-type dozer for excavation to minimize subgrade/groundwater disturbance. Spreading of the first and second layer of aggregate base shall

also be performed with the same type of equipment. The depth and lift thickness of the layers shall be based on the equipment operating weight. Small equipment shall place the material at a minimum of 3 lifts or at the direction of the Engineer. The final lift of the first layer may require some compactive effort (static rolling) for the geogrid to be installed flat and level.

The second layer of aggregate base will require the same spreading equipment. The material will be compacted at 95% density. All compactive effort will be at static rolling (no vibration).

The asphalt layer shall be placed in lift specified in the special provisions. However, the initial breakdown shall require static rolling. Compaction in vibratory mode shall be at the direction of the Engineer.

The Contractor is encouraged to perform review of the site to evaluate conditions and the type of equipment to be used.

Payment:

Full compensation for Subgrade Enhancement Treatment, except as otherwise provided herein, for conforming to the requirements of this article shall be considered as included in the contract bid price for Roadway Excavation and Aggregate Base and no additional compensation will be allowed therefor.

MECHANICALLY STABILIZED LAYER (GEOGRID)

This work includes constructing a mechanically stabilized layer (MSL) with geogrid placed between the subgrade and pavement structure.

MSL geogrid must be Tensar TX7 or equal, and shall have the minimum characteristics shown in the table below:

Properties	Longitudinal	Diagonal	Transverse	General
Rib Pitch, in	1.60	1.60	-	
Mid-rib depth, in	-	0.08	0.06	
Mid-rib width, in	-	0.04	0.06	
Rib Shape				Rectangular
Aperture Shape				Triangular

If proposing an alternative MSL equal to Tensar TX7, the Contractor shall submit the following at least 30 days before use:

1. An MSL design sealed and signed by an Engineer registered in California.
2. Performance testing results documenting calibration and validation in compliance with the following:
 - a. Accelerated pavement testing (APT) conducted in the United States and in compliance with NCHRP Report 512 and Synthesis 325. Performance of pavement sections must be evaluated with standard highway moving wheel loads. Geogrid reinforced sections must be compared to a control section. Testing must be performed on paved structure. Test results of the geogrid section must demonstrate a minimum of 70,000 equivalent single axle loads at less than 1/2 inch rut depth. The rutting performance of the sections must be assessed by trenching. The APT must be continued beyond the rutting failure criterion.
 - b. In-ground performance testing conducted in California and in compliance with AASHTO R50. A minimum of 3 performance tests must be completed on subgrade conditions representative of this project. Reinforced sections must be compared to a control section for each subgrade condition. The testing and evaluation of the geogrid performance shall be conducted by an independent firm and all results of tests and reports shall be signed by an Engineer registered in California.

No proposed equal geogrid shall be accepted based on material index properties, in-air index testing of geogrid properties, or explanations of performance based on material index properties.

The geogrid shall be installed in accordance with this specification and installation guidelines and recommendations by the manufacturer. Additionally, the Contractor shall not:

1. Stockpile material on MSL geogrid
2. Place more MSL geogrid than can be covered in 48 hours

The geogrid may be temporarily secured in place with ties, staples, pins, or backfill or as directed by the Engineer.

When underlying subgrade is firm and stable with minimum rutting, rubber-tired equipment may pass over the MSL geogrid at speeds less than 5 mph. Do not use sudden braking or sharp turning movements.

Damaged or defective geogrid shall be replaced by the Contractor at no additional cost to the County. Replacement of damaged area shall consist of replacing the affected area adding 3 ft of geogrid beyond the limits of the affected area.

Payment:

The contract bid price paid per square yard for Geogrid shall include full compensation for furnishing all labor, tools, material, equipment, and incidentals, and for doing all the work involved and complete in place for two (2) layers of Geogrid in the area of the Asphalt Concrete roadway construction and no additional compensation will be allowed therefor. The quantity shall be measured as one double layer of Geogrid under asphalt concrete surfaces only, and does not include overlap. No adjustment in the bid price for overages or underages from the stated quantity will be allowed.

CONCRETE CURB, GUTTER, CROSS-GUTTER, DRIVEWAY, COMMERCIAL DRIVEWAY, SIDEWALK, BUS PAD AND CURB RAMPS:

Concrete curb, gutter, cross-gutter, driveway approach/tie-in, commercial driveway, sidewalk, bus pad, and curb ramps shall be constructed in accordance with the County Road Improvement Standards And Specifications, or as directed by the Engineer and in conformance with Section 51, 73 and 90 of Standard Specifications.

The Contractor is hereby notified that the existing soils have high sulfate/chloride solution content. In order to decrease the probability of these solutions penetrating the concrete, the concrete mix shall be Class 1 with Type V Portland cement with a maximum W/C ratio of 0.4.

Additionally, an impermeable membrane (6-mil visqueen) and 12 inches of Class II Aggregate Base shall be placed under all concrete improvements.

Preparation of subgrade for the concrete structures shall be done in conformance with the requirements of Section 73-1.02 of the Standard Specifications.

Excess material resulting from the excavation of the subgrade shall be disposed of as elsewhere provided in these Special Specifications. Full compensation for the removal of existing concrete structures shall be included in the contract bid prices for such items.

The Contractor is responsible for meeting all requirements of the Americans with Disability Act (ADA).

Construction of concrete items of work shall include, but not be limited to, the following:

- 1) Removal and disposal of existing sidewalk, driveway approaches, curb, and/or curb and gutter and existing soil and aggregate as required;
- 2) Establishing grades, and assuring that all grades are met;
- 3) Performing all grading and compaction, as directed by the Engineer and in accordance with County Standard 403;

- 4) Construction of new sidewalk, curb, and/or curb and gutter;
- 5) All scoring/grooving and required saw cutting;
- 6) Repair of existing asphalt and PCC surfacing;
- 7) Installing 1/2" wide expansion joints;
- 8) All landscaping, and related work, to return the area adjacent to the curb ramp to its original condition and to conform the area to the new improvements;

At a minimum, the area from the BCR to ECR shall meet all required ADA standards. Therefore, to conform to existing conditions and/or to achieve the required four-foot level area (maximum of 2.0% crossfall) at the top portion of the curb ramp, it may be necessary to extend the work beyond the BCR/ECR in certain instances.

The area behind and along the sidewalk shall be filled and compacted with native or select material and graded to match and provide a smooth transition from the back of sidewalk, to the satisfaction of the Engineer.

Detectable warning surfaces in accordance with ADA requirements and County standards shall be installed as shown on the plans and/or County standards. No additional compensation shall be made for furnishing and installing detectable warning panels.

Measurement:

The quantity of Curb and Gutter shall be measured by linear feet and shall include the length of curb and gutter running through residential Driveway approaches. The quantity does not include the length of curb and gutter running through Commercial Driveway approaches, since curb and gutter in these locations is poured monolithically with the Commercial Driveway approach and paid under the square foot quantity for Commercial Driveway.

The quantities for Curb and Curb and Gutter do not include the length of curb around curb returns, which is poured monolithically with the concrete spandrel. The pay item for Curb Ramp includes all proposed improvements as shown on County Standard No. 403 and details on the plans, including but not limited to: the entire concrete sidewalk and ramp from beginning of curb return (BCR) to end of curb return (ECR); the concrete curb; the concrete spandrel; and the Detectable Warning Surface.

Payment :

The contract unit bid prices paid per linear foot for Curb, Curb And Gutter, square foot for Cross-Gutter, Sidewalk, Driveway, Driveway Tie-In, Commercial Driveway, Bus Pad, and per each for Curb Ramps shall include full compensation for furnishing all labor, equipment, materials and tools, and incidentals, and for doing all the work involved in the construction and complete in place including the furnishing and placing of expansion joints within the right of way and as directed by the Engineer on private property and no additional compensation will be allowed therefor.

DECORATIVE STAMPED CONCRETE (MEDIAN HARDSCAPE) :

Decorative colored stamped concrete shall be constructed as shown on the construction drawings and in accordance with Sections 51, 73 and 90 of the Standard Specifications, the recommendations of the tool and admixture manufacturers, and as directed by the Engineer. Preparation of subgrade for the decorative colored stamped concrete shall be performed in conformance with the requirements of Section 73-1.02 of the Standard Specifications.

The Contractor is hereby notified that the existing soils have high sulfate/chloride solution content. The concrete mix shall be Class 1 with Type V Portland cement with a maximum W/C ratio of 0.4.

Additionally, an impermeable membrane (6-mil visqueen) and 12 inches of Class II Aggregate Base shall be placed under and around all PCC concrete improvements.

The minimum thickness of colored stamped concrete shall be 4 inches. The maximum size aggregate in the top 2 inches shall be 3/8 inch. Stamped concrete shall be imprinted with special tools while in the plastic stage to provide the pattern specific herein.

Colored concrete shall be produced by the integral color method as follows:

- a. Color conditioning admixture shall be added to the concrete in accordance with approved manufacturer's printed instructions. No calcium chloride shall be added to the

concrete. Other non-chloride admixtures may be added subject to the approval of the Engineer. No fly ash admixture shall be added.

- b. Pure mineral pigments shall be added to the concrete in accordance with approved manufacturer's printed instructions. Other admixtures specified or approved by the Engineer shall be added to the concrete in accordance with Section 90-4, "Admixtures" of the Standard Specifications except that no calcium chloride, or other admixture containing ions, and no fly ash shall be used.

Pattern and Finish:

The color and pattern of decorative colored stamped concrete shall be:

Color:

Integral color shall be "5178 Stetson Buff" by L.M. Schofield Co., or close approximation as approved by the Engineer. The listed product is intended as a guideline, and products from alternate manufacturers will be accepted provided that the product and color are close approximations as determined by the Engineer.

Pattern:

The stamped concrete pattern shall be Lithotex Pavecrafters "300 Cobblestone - Random Interlocking", or close approximation as approved by the Engineer. The listed product is intended as a guideline, and products from alternate manufacturers will be accepted provided that the product provides a pattern of the size and texture that is a close approximation to the guideline product.

The pattern shall be implanted, indented, imprinted or stamped into the surface by means of forms, molds, or other approved devices. The impressions shall be approximately 3/8 inch in depth, and shall be ungrouted unless otherwise specified.

The Contractor shall install at least one test panel, in an area not to be incorporated into the work, for the specified color and pattern. The sample shall be a minimum of 20 square feet, which shall be subject to inspection and approval by the Engineer. If

ordered by the Engineer, additional test panels shall be constructed and finished until a satisfactory representation is obtained. The approved test panel shall then be the standard of comparison for enhanced concrete paving. The Contractor shall dispose of the test panel when work is completed, unless otherwise directed by the Engineer.

The Contractor shall provide the Engineer with Certificates of Compliance for all materials used in the imprinting, texturing, coloring, curing, and sealing of decorative colored stamped concrete crossing paving installation, including: Product Name, Supplier, Product Type, and Date of Delivery.

All concrete slabs shall slope to drain. Depressions in the slab surface that hold water will not be accepted.

Expansion joints, joints fillers and joint sealants shall conform to Section 51-1.12 of the Standard Specifications. Joint filler shall be ½ inch wide, premolded, polyethylene expansion foam with a perforated removable top. Remove top of perforated foam filled expansion joint and apply uniform bead of sealant into the joint assuring complete wetting of the bonding surfaces. Thoroughly clean all joint surfaces and apply masking tape to all surfaces adjacent to joints to protect them from primer and sealant residue. Prime all expansion joints carefully. Do not apply primer to any adjacent surfaces.

The decorative colored stamped concrete shall be protected against rapid drying and damage by rain. Keep moist for at least 7 days after placing and protect by wet burlap, canvas covering or liquid-curing compound. If weather is hot or surface has dried out, spray surface with fine mist of water, starting no later than 2 hours after final troweling. Wetting is considered emergency work and shall be performed on weekends and holidays if necessary.

A clear concrete sealer shall be applied between 14 days and 28 days after concrete placement, per manufacturer's written instructions and specifications. The sealed surface shall be finished using a fine brush, which removes residual dust from the surface.

No cutting removal or patching of work will be permitted to correct damaged or defective work; defective sections shall be removed and replaced. Repair of damaged facilities shall be

performed by the Contractor within a reasonable amount of time. No extensions of time will be allowed for correcting defective work.

All decorative colored stamped concrete construction shall be performed by qualified personnel. The Contractor shall provide written evidence demonstrating to the satisfaction of the Engineer that the installer has successfully performed concrete placement and finishing work similar to that specified herein. Such evidence shall include past project documentation and references.

Payment for the construction of decorative colored stamped concrete shall include, but not be limited to, the following, which shall be considered as included in the unit price for Minor Concrete (Stamped Concrete):

1. Removal and disposal of existing surfacing, and existing soil and aggregate as required;
2. Establishing grades, and assuring that all grades are met;
3. Performing all grading and compaction including all required aggregate import;
4. All scoring/grooving, required saw cutting, and specified decorative pattern stamping;
5. Installing ½" wide expansion joints;
6. Construction of stamped concrete, including furnishing and incorporating color admixtures, furnishing and applying color hardeners, and other work as required herein.
7. The construction and removal of test panel(s).

Payment:

The contract bid price paid per square foot for Minor Concrete (Stamped Concrete) shall include full compensation for furnishing all labor, tools, material, equipment, and incidentals, and for doing all the work involved and complete in place and no additional compensation will be allowed therefor.

REMOVE EXISTING FENCE/GATE/WALL AND REPLACE WITH TUBULAR STEEL FENCE:

Existing fence/wall/gate shall be removed and replaced with new tubular steel fence/gate or similar/suitable material as determined by the Engineer, outside the public right-of-way as shown on the construction plans and as directed by the Engineer.

The excess materials from the removals shall become the property of the Contractor.

Materials and finishes:

1. Steel tubing: Cold rolled domestic tubular steel conforming to ASTM A500.
2. Galvanizing: Pre-galvanized 0.9 mil zinc coating.
3. Posts: 2" X 2" square steel (galvanized) tubing as indicated on plans.
4. Rails: 1-3/8" rolled steel (galvanized) tubing as indicated on plans.
5. Pickets: 3/4" rolled steel (galvanized) spaced at 4" on center as indicated on plans.
6. Acrylic/polyester coating: Baked on to a 0.6 mil thickness.
7. Primer: Epoxy polyamide primer electrostatically sprayed on entire panel with 2.0 mil thickness wet coat of primer.
8. Paint: Polyurethane, electrostatically sprayed on entire panel with 2.0 mil thickness wet coat of polyurethane topcoat.
9. Color: Dark brown, as approved by the Engineer.

Delivery, Storage and Handling:

1. Deliver the materials to the job site pre-packed in form and protect against damage to finished surfaces. Stacking shall be done in a way which will prevent bending.

Fabrication:

1. Form all changes in direction by miter/radius elbows.
2. Cut material square and remove burrs from all exposed edges with no chamfer.
3. Make exposed joints butt tight and flush.
4. Close exposed ends by use of appropriate end cap.

Welding:

1. Weld for clean, neat welds continuously around entire length and /or circumference of joint for strength providing a complete seal against the elements.

Dissimilar Materials:

1. When fencing components come into contact with cement or lime mortar, exposed aluminum surfaces shall be painted with an additional coat of 2.0 mil thickness of zinc chromate.

Installation:

1. Where necessary provide shop drawings or review by the Engineer prior to beginning work.
2. Erect work square and level and free from distortion or defects detrimental to appearance or performance.

Cleaning:

1. Remove all welding splatter and grind where necessary for a neat smooth surface along all welds and joints.
2. After welding splatter removal and grinding is completed, wipe down each panel to remove surface dust and oils. Rejuvenate welds with gold galvanization and acrylic.

Repair of Defective Work:

1. Remove stained or otherwise defective work and replace with material that meets specification requirements.

Payment:

The contract bid prices paid per linear foot for Remove Existing Fence/Gate/Wall and Replace with Tubular Steel Fence/Gate shall include full compensation for furnishing all labor, tools, material, equipment, and incidentals, and for doing all work involved including all driveway/pedestrian gates and no additional compensation will be allowed therefor.

THERMOPLASTIC CROSSWALK AND PAVEMENT MARKING:

Thermoplastic crosswalk and pavement markings shall conform to the provisions in Sections 84-1, "General," and 84-2, "Thermoplastic Traffic Stripes and Pavement Markings," of the Standard Specifications and these Special Provisions.

Payment:

The contract unit bid price paid per square foot for Thermoplastic Crosswalk And Pavement Marking shall be considered as full compensation for furnishing all labor, materials, tools, equipment, and incidentals and doing all the work necessary to place the crosswalk and pavement markings complete in place and no additional compensation will be allowed therefor.

PAINT TRAFFIC STRIPE:

Painting traffic stripe shall conform to the provisions in Sections 84-1, "General" and 84-3, "Painted Traffic Stripes and Pavement Markings" of the Standard Specifications and these Special Provisions.

Traffic striping shall be applied in two coats with airless equipment and shall be performed with a roadliner truck mounted striping machine. Where the configuration or location of a traffic stripe is such that the use of a roadliner truck mounted striping machine is unsuitable, traffic striping and glass spheres may be applied by other methods and equipment approved by the Engineer.

Newly painted traffic striping shall be protected from damage by public traffic or other causes until the paint is thoroughly dry. Any newly painted traffic striping which are damaged as a result of the construction, including wheel markings by public traffic and the construction equipment, shall be repainted by the Contractor and any associated removals shall be performed as called for in these Special Provisions.

Full compensation for painting red curb as shown on the plans shall be considered as included in the unit bid price paid per linear foot for Paint Traffic Stripe and no additional compensation will be allowed therefor.

Payment:

The contract price paid per linear foot for Paint Traffic Stripe (2 Coats) shall include full compensation for furnishing all labor, materials, tools, equipment, and incidentals, and for doing all the work involved in painting traffic stripe (regardless of the number, widths, and types of individual stripes involved in each traffic stripe) including any necessary cat tracks, dribble lines any layout work, complete in place as shown on the plans, as specified in the Standard Specifications and these Special Provisions, and as directed by the Engineer.

PAVEMENT MARKERS (REFLECTIVE) :

Pavement markers shall conform to the provisions in Section 85, "Pavement Markers" of the Standard Specifications and these Special Provisions.

Pavement markers shall be placed to the line established by the Engineer. All additional work necessary to establish satisfactory lines for markers shall be performed by the Contractor.

Pavement markers (blue reflective) shall be installed where required in the roadway for all existing fire hydrants per CVWD Standards and per County Standards and Specifications as directed by the Engineer.

Markers and adhesive removal shall be performed by a method approved by the Engineer. Any pavement scarring resulting from the markers removal shall be repaired to the satisfaction of the Engineer.

Payment :

Payment for furnishing and placing Pavement Markers will be at the unit price bid and shall include full compensation for furnishing all labor, materials, tools, equipment and no additional compensation will be allowed therefor.

ROADSIDE SIGNS (INSTALL/RELOCATE) :

Roadside signs (install/relocate) shall conform to the provisions in Section 56-2, "Roadside Signs" of the Standard Specifications, and in accordance with Standard Plans RS2 and as directed by the Engineer.

Roadside signs shall be installed at the locations shown on the construction plans or where directed by the Engineer.

Roadside signs furnished by the Contractor shall be of the standard size specified in the State of California Department of Transportation Sign Specification Sheets, unless otherwise indicated on the construction plans.

Sheeting shall be guaranteed against defects for a period of ten years from the date of fabrication.

The base metal shall be new aluminum, 0.08 gauge, of alloys 6061-T6 or 5052-H38 conforming to the requirements of ASTM Designation: B209.

Any reflective sheeting supplied as a part of this contract, whether as a legend or background, shall be FHWA FP-85 Type IIA or AASHTO M268 Type III.

Reflective sheeting shall be applied to the sign by a method approved by the manufacturer of the sheeting and shall produce a durable bond equal to or greater than the strength of the reflective sheeting. No air pockets or bubbles shall exist between the sheeting and aluminum backing.

The reflective material and screening inks or overlay film shall be graffiti proof. The graffiti proofing method shall be supplied by and/or approved by the sheeting manufacturer. Neither the color nor the reflective intensity of the finished sign shall be significantly diminished by the use of graffiti remover when used in a manner approved by the Transportation Department in conjunction with the sheeting manufacturer. Any signs graffitied by over the counter spray paint or marking pens, which fail to be restored, shall be replaced by the sign sheeting manufacturer.

All letters and numerals shall be in accordance with the "Standard Alphabet of Highway Signs" as used by the State of California, Department of Transportation.

All signs shall be installed using hex head bolts, washers, nuts and jam nuts in accordance with Standard Plans RS2 or as directed by the Engineer.

Payment:

The contract unit prices paid per each for Roadside Signs (Install/Relocate) shall include full compensation for furnishing all labor, materials, tools, equipment, and incidentals and for doing all the work including all necessary concrete, excavation and backfill as specified in the Standard Specification and these Special Provisions and no additional compensation will be allowed therefor.

PEDESTRIAN BARRICADE:

Pedestrian Barricade shall conform to the provisions in Section 83, ``Railings and Barriers'' of the Standard Specifications and details on the plans.

Payment:

The contract unit price paid per linear foot for Pedestrian Barricade shall include full compensation for furnishing all labor, materials, tools, equipment, and incidentals and for doing all the work including all necessary concrete footings, sleeve posts, excavation, and backfill as specified in the Standard Specification, Standard Plan, and these Special Provisions and no additional compensation will be allowed therefor.

MODIFY EXISTING ADA RAMP WITH DETECTABLE WARNING SURFACE:

Modify Existing ADA Ramp With Detectable Warning Surface shall consist of applying a bolt-down detectable warning surface in compliance with County Standard No. 403, as well reducing the curb face along the bottom of the existing curb ramp to 0-inches. This shall be done by grinding or horizontal sawcut operation, as approved by the Engineer.

Payment:

Payment for Modify Existing ADA Ramp With Detectable Warning Surface shall be at the unit price for each, and shall be considered full compensation for meeting ADA requirements for providing a detectable warning surface in accordance with County standards and for reducing the curb face to 0-inches, and no additional compensation will be allowed therefor.

MISCELLANEOUS DIRECTED WORK:

Miscellaneous directed work shall consist of necessary work that is not included in other contract bid items, as determined by the Engineer. Miscellaneous directed work shall be performed as directed by the Engineer and in accordance with the applicable standards and specifications. Payment for implementing miscellaneous directed work will be paid for on a force account basis, with an allowable 15% maximum mark up for labor,

equipment, and material and no other applicable mark ups will be allowed, in accordance with Caltrans Labor Surcharge and Equipment Rental Rates, latest edition, up to the fixed bid price, for the work performed.

Payment:

Payment for implementing miscellaneous directed work will be paid for on a force account basis, in accordance with Section 9-1.03 of the Standard Specifications, up to the fixed bid price, for the work performed

LIGHTING:

The street lighting system shall be constructed in accordance with the current edition of the National Electric Code, the standards and specifications of the Imperial Irrigation District, the electrical plans as prepared by the Imperial Irrigation District, which are included in the plan set issued to plan holders, and as directed by the Engineer.

The standards and specifications of the Imperial Irrigation District, entitled "Developer Energy Planning Guide" and "Electrical Service and Metering Equipment Guide" will be posted on the County of Riverside Transportation Department's public works bidding website (http://www.tlma.co.riverside.ca.us/trans/con_bid_advertisements.html) during the bid period. These documents, and additional information are also available at the Imperial Irrigation District's website, <http://iid.com/Energy/NewConstruction>. The Contractor shall provide necessary coordination with the Imperial Irrigation District for all work associated with the street lighting system.

The Contractor shall furnish and install all conduits, conductors, trenching, trench backfill, street lighting foundations, transformer foundations, conduit and pull ropes between transformer pads and power poles, including sweeps and 10 feet of riser conduit, street light standards and luminaires, and shall perform all other work and furnish all other materials required for the installation of the street lighting system, complete and in-place, except for the specific tasks that will be performed by the Imperial Irrigation District, as listed below.

The Imperial Irrigation District, as owner of the electrical system, will furnish and install transformers, furnish and connect conductors between transformers and primary electric conductors, install risers on power poles, and will make final connections of street lighting conductors to transformers. Imperial Irrigation District will remove existing street lights after installation and energization of the new street lighting system.

The scope of work includes the installation of 250 watt, 25,000 lumen and 100 watt, 8,000 lumen high pressure sodium street lights, poles, including but not limited to foundations, conduits, pull ropes, trenching, and all other work required, as specified herein and as shown on the lighting plans. All work shall be performed in coordination with the Imperial Irrigation District.

The following work shall be considered as included in scope of work, and shall be included in the lump sum contract price paid for Lighting. This clarification is provided in as much as the lighting plans include future work outside of the Phase 3 street improvement limits, and the connection to the listed service points are required in order to provide electrical service to the Phase 3 lighting system.

Installation of conduit, pull rope, trenching, backfill, and connection to pad-mount transformer and/or 10 foot riser sweep, as appropriate, to lighting service points as follows and as shown on the IID Conduit Layout plan:

All existing wood street lighting poles will be removed by the Imperial Irrigation District in coordination with the Contractor's work. All existing steel street lighting poles will be removed by the Contractor. Existing street lights shall not be removed or de-energized until the new street lighting system is energized and operational. The Contractor shall be fully responsible for all coordination with the Imperial Irrigation District for the installation of the new street lighting system.

Street light poles (standards) and mast arms shall substantially conform to County of Riverside standard numbers 1000 and 1001. Poles and mast-arms shall be galvanized steel. Contractor shall submit manufacturer's specifications to the engineer for approval prior to placing equipment order. Approval by the Imperial Irrigation District shall be required with respect to poles,

mast-arms and luminaire mounting height. The requirements of Standards 1000 and 1001 with respect to high sulfate content of abutting soil are applicable with respect to PCC foundations, transformer pads and other cast in place PCC improvements associated with the street lighting system, and in accordance with Section 16.04 of County of Riverside Ordinance no. 461, Cement Type V shall be utilized with a minimum of 715 Lbs/CY cement content, and a minimum of 12 inches of Class II Aggregate Base constructed between the PCC and native soil. Additionally, 6 mil plastic sheeting shall be installed between PCC and Class II Aggregate base.

Contractor is required to maintain functional existing lighting system for the duration of the project as specified in Section 7-1.08 Public Convenience and Section 7-1.09 Public Safety. Any temporary relocation of existing street lighting, poles, conduits, and wiring shall be performed as required to facilitate the construction per plan and/or as directed by the Engineer. No additional compensation will be allowed for temporary improvement.

Payment:

Full compensation for the installation of the street lighting system shall be considered as included in the lump sum price paid for Lighting per plan, addendums, and Imperial Irrigation District general requirements, including all labor, equipment, personnel and incidentals, and including all necessary coordination with the Imperial Irrigation District.

SOLAR POWERED FLASHING BEACON SYSTEM:

Furnishing and installing solar powered advanced flashing beacons and payment shall conform to the provisions in Section 86, "Signals and Lighting" of the Standard Specifications and these Special Provisions.

Each unit shall consist of a self-contained solar engine, dual LED signal modules and signal housing, and mounting hardware such that the entire assembly mounts to the top of the pole. The solar engine shall contain all electronics, batteries & solar panels. No additional cabinet is required. The system shall conform to all provisions of the MUTCD, Chapter 4K, Flashing Beacons.

Mechanical Specifications

The solar engine shall be constructed from powder coated aluminum, and shall be no greater in size than 4.75" x 15" x 32". The Solar panels shall be integrated to the solar engine. All batteries and electronics shall be mounted in the solar engine, with no external control cabinet or battery cabinet required. The solar engine shall be vented to provide cooling of the battery and electronic system. Venting shall be covered by wire mesh to prevent intrusion of insects.

The solar engine shall have the provision to mount an external device for remote activation. System must have capability to power such device. Solar engine must contain sufficient space to house third party device inside a sealed enclosure located inside the solar engine.

The overall weight of the assembly, including mounting hardware, signal housings, LED modules, and solar engine shall not exceed 75 lbs.

The solar engine shall have the provision to be tilted and oriented south with additional mounting hardware, or mounted completely flat to the ground such that mounting in any orientation will keep the solar engine level.

Mounting

The entire assembly, including solar engine, signal housing and LED module, and bracket shall be provided with hardware for mounting on to the top of a 4 1/2" diameter round pole. Mounting hardware shall be standard traffic signal mounting hardware manufactured by Pelco Products Inc.

Solar/Battery System

The solar engine shall include two 10-watt solar panels no larger than the footprint of the housing. The solar engine shall house two, field replaceable sealed lead acid batteries no greater than 24 Ah each. The solar panel and battery system shall be 12 Volt DC.

The solar panel shall meet the design qualification and type approval of photovoltaic modules in accordance with IEC 61215. This specification includes radiation testing, thermal testing,

and mechanical testing for environmental conditions such as UV-exposure, thermal cycling, as well as degradation of maximum power output.

The solar panel shall consist of no more than two solar panels, mounted to the solar engine with an aluminum flashing.

The batteries shall be mechanically secured into the housing. A battery bracket shall enclose each battery in a manner to restrict the thermal expansion of the battery.

System shall have an auxiliary 12 VDC power output to power third party devices such as wireless radios or sensing equipment.

Signal Housing

The signal housing shall meet the equipment standard of the Institute of Transportation Engineers (ITE) Vehicle Traffic Control Signal Heads (VTCSH) Chapter 2.

The solar engine shall not overhang the signal head, so as not to restrict mounting a signal head back plate. The signal head shall be easily removable from the assembly. The bracket assembly shall be constructed such that the signal heads can be removed easily in the field without removing the solar engine. The bracket assembly shall be designed to take the torsion and bending load of the solar engine. The signal head shall not be subjected to the torsional or bending load of the solar engine.

The signal housing must be able to rotate independent from the bracket for lens alignment. The dual flashing beacons shall be mounted horizontally and the signal housing shall be black in color.

LED Signal Module

The LED signal module shall be yellow and conform to the mandatory specifications of: ITE Vehicle Traffic Control Signal Heads, Light Emitting Diode (LED) Circular Signal Supplement as required by the Manual of Uniform Traffic Control Devices 2003 Edition Revision 1.

Operational Specifications

The system shall conform to all standards for flashing beacons as required in the Manual of Uniform Traffic Control Devices 2003 Edition Revision 1 or current version.

The beacon shall flash at a rate of not less than 50 or more than 60 times per minute. The illuminated period of each flash shall not be less than one-half and not more than two-thirds of the total cycle.

The beacon shall have a night dimming feature.

The beacon shall have a minimum operating autonomy of 30 days.

The beacon shall automatically reduce light output in case of low battery situations, reducing risk that the beacons will fail entirely under conditions of poor solar insolation.

Activation

The beacon shall operate continuously when the battery is connected. The beacon shall have the option to be turned on by a third party switch or third party device with a compatible contact closure output.

Environmental Specifications

The system shall be able to withstand and operate at temperature extremes of -40 degree F to +122 degree F.

The system shall be designed and constructed to withstand 178 Km/h (110 mph) wind loads in conformance with the requirements of the AASHTO publication, "Standard Specifications for Structural Supports of Highway Signs, Luminaries and Traffic Signals", 4th Edition 2001.

The electronic circuit board housing, wire harnessing and connectors shall be designed and tested in accordance to IEC International Standard 60529, Ingress Protection IP67 requiring that the enclosure be dust tight and remain completely sealed when immersed in water to a depth of 1 meter for 1 hour.

The LED Module shall meet the following environmental tests as specified in the ITE Vehicle Traffic Control Signal Heads, Light Emitting Diode (LED) Circular Signal Supplement:

Mechanical vibration: MIL-STD-883
Temperature cycling: MIL-STD-883
Moisture resistance: MIL-STD-810F.

Electrical Standards

Integrated solar charger shall be approved to CSA and UL standards.

Quality Assurance

The product must be FCC certified to comply with all 47 CFR FCC Part 15 Subpart B Emission requirements.

The system, including battery packs, solar panel, LED modules and all components, shall be guaranteed for a minimum of three years.

Manufacturer must be ISO 9001 certified.

Payment:

The lump sum price paid for Flashing Beacon System shall include full compensation for furnishing all materials including regulatory and warning signs as shown on the plans, equipment and labor and doing all work necessary to the satisfaction of the Engineer.

OBSTRUCTIONS:

Attention is directed to Sections 8-1.10, "Utility and Non-Highway Facilities", and 15, "Existing Highway Facilities" of the Standard Specifications and these Special Provisions.

Existing utility and privately owned facilities shall be protected in accordance with Section 7-1.11, "Preservation of Property" and these Special Provisions. The Contractor is also responsible to protect those facilities that are to be relocated by others prior to or during construction, and shall protect those facilities in both their existing and their ultimate locations. The Contractor shall cooperate with owners and their Contractors of utility and privately owned facilities, for the

relocation of said facilities, in accordance with Section 7-1.14, ``Cooperation'' of the Standard Specifications.

All water valves, gas valves, sewer manholes, survey monuments, survey markers and any other utility appurtenances shall be protected in place. This protection includes any valve/manhole/monument or other utility appurtenance which requires the Contractor to adjust to grade prior to and/or during roadway excavation operations in order to protect the health, safety, and welfare of the public. Full compensation for such protection shall be considered as included in the various bid items.

The Contractor's attention is directed to the existence of certain underground facilities that may require special precautions be taken by the Contractor to protect the health, safety and welfare of workmen and the public. Facilities requiring special precautions include, but are not limited to: conductors of petroleum products, oxygen, chlorine, and toxic or flammable gases; natural gas in pipe lines greater than 6 inches in diameter or pipe lines operating at pressures greater than 60 psi (gage); underground electric supply system conductors or cables either directly buried or in duct or conduit which do not have concentric neutral conductors or other effectively grounded metal shields or sheaths; and underground electrical conductors with potential to ground of more than 300 volts. The Contractor shall notify the Engineer at least twenty-four hours prior to performing any work in the vicinity of such facilities.

Due to the depth of excavation to achieve subgrade stabilization, the Contractor is advised that subsurface utilities may be near the grading plane. The Contractor shall exercise caution and use small equipment in and around existing utilities in order to protect all existing utilities. Attention is also directed to the requirements of the special provision entitled "Subgrade Enhancement Treatment".

Attention is directed to the requirements of Government Code Sections 4216-4216.9 pertaining to existing utility facilities.

The Contractor shall assume that every house, building and lot within the project limits has utility service pipes and conductors (laterals), and that utility main and trunk facilities exist within the project limits. The Contractor shall determine if it is warranted to determine the exact location of these

utility service laterals and existing main lines, unless directed by the Engineer to pot-hole at specific locations, or as otherwise required herein. The Contractor will not be directly reimbursed for determining the exact location of the utility main lines or services laterals but shall include any compensation for this work in the contract price paid for the various items of work. Any damage to existing main lines or service laterals for which pot-holing was not performed shall be considered damage due to not using reasonable care and the damage shall be repaired at the Contractor's expense.

The Contractor shall conduct his operations with the assumption that underground utility facilities exist within the project limits. The Contractor shall exercise caution and best construction practices for safety and for protection of underground facilities. The approximate locations of underground utility facilities, as shown on the plans, are based on information provided by the respective owners, listed below. The Contractor shall also utilize the markings of the regional notification center (Underground Service Alert), and above-ground utility appurtenances to determine the existence and approximate location of underground utilities.

No excavation shall be made within 4 feet of any underground utilities, as listed below, unless and until such utilities have been positively located as to horizontal and vertical position. This requirement applies to all underground electric, natural gas, toxic or flammable gas, chlorine, oxygen or petroleum facilities.

Forty-eight hours prior to beginning construction, the Contractor shall notify the following agencies:

Underground Service Alert	800-227-2600 or 811
Southern California Edison Company	909-930-8497
Southern California Gas Company	909-335-7716
Verizon	760-327-8648
Coachella Valley Water District	760-398-2651
Imperial Irrigation District	760-398-5820
Level 3 Communications	720-888-3813
Cable USA	760-767-5607
USA Companies	760-346-2155

Payment:

Full compensation for all costs, including labor, equipment, materials and incidentals, required to comply with the requirements of this section shall be considered as included in the various items of work, and no additional compensation will be allowed therefor.

Adjustments to Grade for Obstructions

The Contractor shall adjust to finish grade any valve covers encountered within the project limits, as required, for those utility valves that are provided with slip cans and are adjustable without the replacement of parts or the removal of concrete collars. In cases where the owning utility company insists upon upgrades in the standards, or when additional parts or the removal of concrete collars are required for the adjustment, said adjustment will be the responsibility of the owning utility company.

Communication and coordination with the owning utility company shall be the responsibility of the contractor.

For public safety, traffic shall not be allowed on temporary or permanent pavement until all manholes are either adjusted to grade or otherwise protected, as approved by the Engineer. The Contractor shall adjust to grade manholes and valves when and as necessary for the protection of the traveling public during construction, and shall coordinate all work on said facilities with the owning utility companies. This requirement is intended for traffic that is to be allowed on temporary surfaces during the course of construction. Final adjustment to grade will be the responsibility of the owning utility company, except as provided herein.

Said work shall be performed in accordance with Section 15-2.05A, "Frames, Covers, Grates, and Manholes" of the Standard Specifications. Full compensation for adjustment of valve covers shall be considered as included in the contract price paid for asphalt concrete, or applicable items of work in the event that there is no asphalt concrete bid item, and no additional compensation will be allowed therefor.

All existing utility facilities shall be protected from damage by the Contractor's operations.

Unless otherwise provided herein, the owning utility companies will not be obligated to lower their surface utilities (manholes and valve covers) for Contractor's grading, grinding and/or paving operations. The contractor shall lower surface facilities, including manholes and valve covers, to facilitate construction, and the following shall apply:

1. Contractor shall coordinate all work with the utility owner.
2. Contractor shall be responsible for all costs and shall be responsible for any damage caused to the owner's facilities. If the Contractor observes any pre-existing damage to the utility facilities, the Contractor shall notify the Engineer and the utility owner of that damage prior to performing additional work on the facility.
3. Contractor shall, after removing grade rings and covers, arrange for pickup by, or delivery to, the owner's yard. Any and all concrete collars removed by the Contractor shall become the property of the Contractor, and shall be disposed of as specified elsewhere in these special provisions.
4. The Contractor is advised that he is responsible for ensuring that construction materials do not enter the utility owner's facilities. The Contractor shall install traffic bearing steel plates for this purpose, and provide all coordination and transportation necessary. It is recommended that the Contractor request the utility owner to provide such steel plates. If the Contractor provides steel plates, it shall be the Contractor's responsibility to coordinate with the utility owner for the return of the steel plates to the Contractor after final adjustment to grade. If the Contractor utilizes utility owner's steel plates, and if the Contract items of work include adjustment to final grade, the Contractor shall return the steel plates to the Utility owner's yard, or as otherwise arranged with the Utility owner.
5. Prior to paving or covering the plated utility facility, the Contractor shall tie-out the facility utilizing a method acceptable to the utility owner and provide notes and data of all covered facilities to both the utility owner and the Engineer.
6. The Contractor shall notify the utility owner, upon completion of the Contractor's work, when the utility owner may move in to make the final adjustments to grade.

7. The requirements for lowering of surface facilities shall not apply to vaults. The Contractor shall notify the utility owner of the need to make adjustments to such major facilities.
8. The Contractor is reminded that the utility facilities are owned by public and private utility companies that operate their facilities within public rights of way. The utility owner's preferences with regards to the handling of its facilities shall be complied with to the greatest extent feasible.

Method of Payment

Full compensation for initial lowering of surface utilities facilities shall be considered as included in the contract price paid for asphalt concrete, or applicable items of work in the event that there is no asphalt concrete bid item, and no additional compensation will be allowed therefor.

APPENDIX A

Attachment "C" for Risk Level 1 Requirements

Of Water Pollution Control

ATTACHMENT C RISK LEVEL 1 REQUIREMENTS

A. Effluent Standards

[These requirements are the same as those in the General Permit order.]

1. Narrative – Risk Level 1 dischargers shall comply with the narrative effluent standards listed below:
 - a. Storm water discharges and authorized non-storm water discharges regulated by this General Permit shall not contain a hazardous substance equal to or in excess of reportable quantities established in 40 C.F.R. §§ 117.3 and 302.4, unless a separate NPDES Permit has been issued to regulate those discharges.
 - b. Dischargers shall minimize or prevent pollutants in storm water discharges and authorized non-storm water discharges through the use of controls, structures, and management practices that achieve BAT for toxic and non-conventional pollutants and BCT for conventional pollutants.
2. Numeric – Risk Level 1 dischargers are not subject to a numeric effluent standard.

B. Good Site Management "Housekeeping"

1. Risk Level 1 dischargers shall implement good site management (i.e., "housekeeping") measures for construction materials that could potentially be a threat to water quality if discharged. At a minimum, Risk Level 1 dischargers shall implement the following good housekeeping measures:
 - a. Conduct an inventory of the products used and/or expected to be used and the end products that are produced and/or expected to be produced. This does not include materials and equipment that are designed to be outdoors and exposed to environmental conditions (i.e. poles, equipment pads, cabinets, conductors, insulators, bricks, etc.).
 - b. Cover and berm loose stockpiled construction materials that are not actively being used (i.e. soil, spoils, aggregate, fly-ash, stucco, hydrated lime, etc.).

- c. Store chemicals in watertight containers (with appropriate secondary containment to prevent any spillage or leakage) or in a storage shed (completely enclosed).
 - d. Minimize exposure of construction materials to precipitation. This does not include materials and equipment that are designed to be outdoors and exposed to environmental conditions (i.e. poles, equipment pads, cabinets, conductors, insulators, bricks, etc.).
 - e. Implement BMPs to prevent the off-site tracking of loose construction and landscape materials.
2. Risk Level 1 dischargers shall implement good housekeeping measures for waste management, which, at a minimum, shall consist of the following:
- a. Prevent disposal of any rinse or wash waters or materials on impervious or pervious site surfaces or into the storm drain system.
 - b. Ensure the containment of sanitation facilities (e.g., portable toilets) to prevent discharges of pollutants to the storm water drainage system or receiving water.
 - c. Clean or replace sanitation facilities and inspecting them regularly for leaks and spills.
 - d. Cover waste disposal containers at the end of every business day and during a rain event.
 - e. Prevent discharges from waste disposal containers to the storm water drainage system or receiving water.
 - f. Contain and securely protect stockpiled waste material from wind and rain at all times unless actively being used.
 - g. Implement procedures that effectively address hazardous and non-hazardous spills.
 - h. Develop a spill response and implementation element of the SWPPP prior to commencement of construction activities. The SWPPP shall require that:
 - i. Equipment and materials for cleanup of spills shall be available on site and that spills and leaks shall be cleaned up immediately and disposed of properly; and

- ii. Appropriate spill response personnel are assigned and trained.
 - i. Ensure the containment of concrete washout areas and other washout areas that may contain additional pollutants so there is no discharge into the underlying soil and onto the surrounding areas.
3. Risk Level 1 dischargers shall implement good housekeeping for vehicle storage and maintenance, which, at a minimum, shall consist of the following:
 - a. Prevent oil, grease, or fuel to leak in to the ground, storm drains or surface waters.
 - b. Place all equipment or vehicles, which are to be fueled, maintained and stored in a designated area fitted with appropriate BMPs.
 - c. Clean leaks immediately and disposing of leaked materials properly.
4. Risk Level 1 dischargers shall implement good housekeeping for landscape materials, which, at a minimum, shall consist of the following:
 - a. Contain stockpiled materials such as mulches and topsoil when they are not actively being used.
 - b. Contain fertilizers and other landscape materials when they are not actively being used.
 - c. Discontinue the application of any erodible landscape material within 2 days before a forecasted rain event or during periods of precipitation.
 - d. Apply erodible landscape material at quantities and application rates according to manufacture recommendations or based on written specifications by knowledgeable and experienced field personnel.
 - e. Stack erodible landscape material on pallets and covering or storing such materials when not being used or applied.
5. Risk Level 1 dischargers shall conduct an assessment and create a list of potential pollutant sources and identify any areas of the site where additional BMPs are necessary to reduce or prevent pollutants in storm water discharges and authorized non-storm water discharges. This potential pollutant list shall be kept with the SWPPP and shall identify

all non-visible pollutants which are known, or should be known, to occur on the construction site. At a minimum, when developing BMPs, Risk Level 1 dischargers shall do the following:

- a. Consider the quantity, physical characteristics (e.g., liquid, powder, solid), and locations of each potential pollutant source handled, produced, stored, recycled, or disposed of at the site.
 - b. Consider the degree to which pollutants associated with those materials may be exposed to and mobilized by contact with storm water.
 - c. Consider the direct and indirect pathways that pollutants may be exposed to storm water or authorized non-storm water discharges. This shall include an assessment of past spills or leaks, non-storm water discharges, and discharges from adjoining areas.
 - d. Ensure retention of sampling, visual observation, and inspection records.
 - e. Ensure effectiveness of existing BMPs to reduce or prevent pollutants in storm water discharges and authorized non-storm water discharges.
6. Risk Level 1 dischargers shall implement good housekeeping measures on the construction site to control the air deposition of site materials and from site operations. Such particulates can include, but are not limited to, sediment, nutrients, trash, metals, bacteria, oil and grease and organics.

C. Non-Storm Water Management

1. Risk Level 1 dischargers shall implement measures to control all non-storm water discharges during construction.
2. Risk Level 1 dischargers shall wash vehicles in such a manner as to prevent non-storm water discharges to surface waters or MS4 drainage systems.
3. Risk Level 1 dischargers shall clean streets in such a manner as to prevent unauthorized non-storm water discharges from reaching surface water or MS4 drainage systems.

D. Erosion Control

1. Risk Level 1 dischargers shall implement effective wind erosion control.
2. Risk Level 1 dischargers shall provide effective soil cover for inactive¹ areas and all finished slopes, open space, utility backfill, and completed lots.
3. Risk Level 1 dischargers shall limit the use of plastic materials when more sustainable, environmentally friendly alternatives exist. Where plastic materials are deemed necessary, the discharger shall consider the use of plastic materials resistant to solar degradation.

E. Sediment Controls

1. Risk Level 1 dischargers shall establish and maintain effective perimeter controls and stabilize all construction entrances and exits to sufficiently control erosion and sediment discharges from the site.
2. On sites where sediment basins are to be used, Risk Level 1 dischargers shall, at minimum, design sediment basins according to the method provided in CASQA's Construction BMP Guidance Handbook.

F. Run-on and Runoff Controls

Risk Level 1 dischargers shall effectively manage all run-on, all runoff within the site and all runoff that discharges off the site. Run-on from off site shall be directed away from all disturbed areas or shall collectively be in compliance with the effluent limitations in this General Permit.

G. Inspection, Maintenance and Repair

1. Risk Level 1 dischargers shall ensure that all inspection, maintenance repair and sampling activities at the project location shall be performed or supervised by a Qualified SWPPP Practitioner (QSP) representing the discharger. The QSP may delegate any or all of these activities to an employee trained to do the task(s) appropriately, but shall ensure adequate deployment.
2. Risk Level 1 dischargers shall perform weekly inspections and observations, and at least once each 24-hour period during extended

¹ Inactive areas of construction are areas of construction activity that have been disturbed and are not scheduled to be re-disturbed for at least 14 days.

storm events, to identify and record BMPs that need maintenance to operate effectively, that have failed, or that could fail to operate as intended. Inspectors shall be the QSP or be trained by the QSP.

3. Upon identifying failures or other shortcomings, as directed by the QSP, Risk Level 1 dischargers shall begin implementing repairs or design changes to BMPs within 72 hours of identification and complete the changes as soon as possible.
4. For each inspection required, Risk Level 1 dischargers shall complete an inspection checklist, using a form provided by the State Water Board or Regional Water Board or in an alternative format.
5. Risk Level 1 dischargers shall ensure that checklists shall remain onsite with the SWPPP and at a minimum, shall include:
 - a. Inspection date and date the inspection report was written.
 - b. Weather information, including presence or absence of precipitation, estimate of beginning of qualifying storm event, duration of event, time elapsed since last storm, and approximate amount of rainfall in inches.
 - c. Site information, including stage of construction, activities completed, and approximate area of the site exposed.
 - d. A description of any BMPs evaluated and any deficiencies noted.
 - e. If the construction site is safely accessible during inclement weather, list the observations of all BMPs: erosion controls, sediment controls, chemical and waste controls, and non-storm water controls. Otherwise, list the results of visual inspections at all relevant outfalls, discharge points, downstream locations and any projected maintenance activities.
 - f. Report the presence of noticeable odors or of any visible sheen on the surface of any discharges.
 - g. Any corrective actions required, including any necessary changes to the SWPPP and the associated implementation dates.
 - h. Photographs taken during the inspection, if any.
 - i. Inspector's name, title, and signature.

H. Rain Event Action Plan

Not required for Risk Level 1 dischargers.

I. Risk Level 1 Monitoring and Reporting Requirements

Table 1- Summary of Monitoring Requirements

Risk Level	Visual Inspections					Sample Collection	
	Quarterly Non-storm Water Discharge	Pre-storm Event		Daily Storm BMP	Post Storm	Storm Water Discharge	Receiving Water
		Baseline	REAP				
1	X	X		X	X		

1. Construction Site Monitoring Program Requirements

- a. Pursuant to Water Code Sections 13383 and 13267, all dischargers subject to this General Permit shall develop and implement a written site-specific Construction Site Monitoring Program (CSMP) in accordance with the requirements of this Section. The CSMP shall include all monitoring procedures and instructions, location maps, forms, and checklists as required in this section. The CSMP shall be developed prior to the commencement of construction activities, and revised as necessary to reflect project revisions. The CSMP shall be a part of the Storm Water Pollution Prevention Plan (SWPPP), included as an appendix or separate SWPPP chapter.
- b. Existing dischargers registered under the State Water Board Order No. 99-08-DWQ shall make and implement necessary revisions to their Monitoring Programs to reflect the changes in this General Permit in a timely manner, but no later than July 1, 2010. Existing dischargers shall continue to implement their existing Monitoring Programs in compliance with State Water Board Order No. 99-08-DWQ until the necessary revisions are completed according to the schedule above.
- c. When a change of ownership occurs for all or any portion of the construction site prior to completion or final stabilization, the new discharger shall comply with these requirements as of the date the ownership change occurs.

2. Objectives

The CSMP shall be developed and implemented to address the following objectives:

- a. To demonstrate that the site is in compliance with the Discharge Prohibitions;

- b. To determine whether non-visible pollutants are present at the construction site and are causing or contributing to exceedances of water quality objectives;
 - c. To determine whether immediate corrective actions, additional Best Management Practice (BMP) implementation, or SWPPP revisions are necessary to reduce pollutants in storm water discharges and authorized non-storm water discharges; and
 - d. To determine whether BMPs included in the SWPPP are effective in preventing or reducing pollutants in storm water discharges and authorized non-storm water discharges.
- 3. Risk Level 1 - Visual Monitoring (Inspection) Requirements for Qualifying Rain Events**
- a. Risk Level 1 dischargers shall visually observe (inspect) storm water discharges at all discharge locations within two business days (48 hours) after each qualifying rain event.
 - b. Risk Level 1 dischargers shall visually observe (inspect) the discharge of stored or contained storm water that is derived from and discharged subsequent to a qualifying rain event producing precipitation of ½ inch or more at the time of discharge. Stored or contained storm water that will likely discharge after operating hours due to anticipated precipitation shall be observed prior to the discharge during operating hours.
 - c. Risk Level 1 dischargers shall conduct visual observations (inspections) during business hours only.
 - d. Risk Level 1 dischargers shall record the time, date and rain gauge reading of all qualifying rain events.
 - e. Within 2 business days (48 hours) prior to each qualifying rain event, Risk Level 1 dischargers shall visually observe (inspect):
 - i. All storm water drainage areas to identify any spills, leaks, or uncontrolled pollutant sources. If needed, the discharger shall implement appropriate corrective actions.
 - ii. All BMPs to identify whether they have been properly implemented in accordance with the SWPPP. If needed, the discharger shall implement appropriate corrective actions.

- iii. Any storm water storage and containment areas to detect leaks and ensure maintenance of adequate freeboard.
- f. For the visual observations (inspections) described in e.i and e.iii above, Risk Level 1 dischargers shall observe the presence or absence of floating and suspended materials, a sheen on the surface, discolorations, turbidity, odors, and source(s) of any observed pollutants.
- g. Within two business days (48 hours) after each qualifying rain event, Risk Level 1 dischargers shall conduct post rain event visual observations (inspections) to (1) identify whether BMPs were adequately designed, implemented, and effective, and (2) identify additional BMPs and revise the SWPPP accordingly.
- h. Risk Level 1 dischargers shall maintain on-site records of all visual observations (inspections), personnel performing the observations, observation dates, weather conditions, locations observed, and corrective actions taken in response to the observations.

4. Risk Level 1 – Visual Observation Exemptions

- a. Risk Level 1 dischargers shall be prepared to conduct visual observation (inspections) until the minimum requirements of Section I.3 above are completed. Risk Level 1 dischargers are not required to conduct visual observation (inspections) under the following conditions:
 - i. During dangerous weather conditions such as flooding and electrical storms.
 - ii. Outside of scheduled site business hours.
- b. If no required visual observations (inspections) are collected due to these exceptions, Risk Level 1 dischargers shall include an explanation in their SWPPP and in the Annual Report documenting why the visual observations (inspections) were not conducted.

5. Risk Level 1 – Monitoring Methods

Risk Level 1 dischargers shall include a description of the visual observation locations, visual observation procedures, and visual observation follow-up and tracking procedures in the CSMP.

6. Risk Level 1 – Non-Storm Water Discharge Monitoring Requirements

- a. Visual Monitoring Requirements:
- i. Risk Level 1 dischargers shall visually observe (inspect) each drainage area for the presence of (or indications of prior) unauthorized and authorized non-storm water discharges and their sources.
 - ii. Risk Level 1 dischargers shall conduct one visual observation (inspection) quarterly in each of the following periods: January-March, April-June, July-September, and October-December. Visual observation (inspections) are only required during daylight hours (sunrise to sunset).
 - iii. Risk Level 1 dischargers shall ensure that visual observations (inspections) document the presence or evidence of any non-storm water discharge (authorized or unauthorized), pollutant characteristics (floating and suspended material, sheen, discoloration, turbidity, odor, etc.), and source. Risk Level 1 dischargers shall maintain on-site records indicating the personnel performing the visual observation (inspections), the dates and approximate time each drainage area and non-storm water discharge was observed, and the response taken to eliminate unauthorized non-storm water discharges and to reduce or prevent pollutants from contacting non-storm water discharges.

7. Risk Level 1 – Non-Visible Pollutant Monitoring Requirements

- a. Risk Level 1 dischargers shall collect one or more samples during any breach, malfunction, leakage, or spill observed during a visual inspection which could result in the discharge of pollutants to surface waters that would not be visually detectable in storm water.
- b. Risk Level 1 dischargers shall ensure that water samples are large enough to characterize the site conditions.
- c. Risk Level 1 dischargers shall collect samples at all discharge locations that can be safely accessed.
- d. Risk Level 1 dischargers shall collect samples during the first two hours of discharge from rain events that occur during business hours and which generate runoff.
- e. Risk Level 1 dischargers shall analyze samples for all non-visible pollutant parameters (if applicable) - parameters indicating the

presence of pollutants identified in the pollutant source assessment required (Risk Level 1 dischargers shall modify their CSMPs to address these additional parameters in accordance with any updated SWPPP pollutant source assessment).

- f. Risk Level 1 dischargers shall collect a sample of storm water that has not come in contact with the disturbed soil or the materials stored or used on-site (uncontaminated sample) for comparison with the discharge sample.
- g. Risk Level 1 dischargers shall compare the uncontaminated sample to the samples of discharge using field analysis or through laboratory analysis.²
- h. Risk Level 1 dischargers shall keep all field /or analytical data in the SWPPP document.

8. Risk Level 1 – Particle Size Analysis for Project Risk Justification

Risk Level 1 dischargers justifying an alternative project risk shall report a soil particle size analysis used to determine the RUSLE K-Factor. ASTM D-422 (Standard Test Method for Particle-Size Analysis of Soils), as revised, shall be used to determine the percentages of sand, very fine sand, silt, and clay on the site.

9. Risk Level 1 – Records

Risk Level 1 dischargers shall retain records of all storm water monitoring information and copies of all reports (including Annual Reports) for a period of at least three years. Risk Level 1 dischargers shall retain all records on-site while construction is ongoing. These records include:

- a. The date, place, time of facility inspections, sampling, visual observation (inspections), and/or measurements, including precipitation.
- b. The individual(s) who performed the facility inspections, sampling, visual observation (inspections), and or measurements.
- c. The date and approximate time of analyses.
- d. The individual(s) who performed the analyses.

² For laboratory analysis, all sampling, sample preservation, and analyses must be conducted according to test procedures under 40 CFR Part 136. Field discharge samples shall be collected and analyzed according to the specifications of the manufacturer of the sampling devices employed.

- e. A summary of all analytical results from the last three years, the method detection limits and reporting units, and the analytical techniques or methods used.
- f. Rain gauge readings from site inspections.
- g. Quality assurance/quality control records and results.
- h. Non-storm water discharge inspections and visual observation (inspections) and storm water discharge visual observation records (see Sections I.3 and I.6 above).
- i. Visual observation and sample collection exception records (see Section I.4 above).
- j. The records of any corrective actions and follow-up activities that resulted from analytical results, visual observation (inspections), or inspections.

REFERENCE DRAWINGS

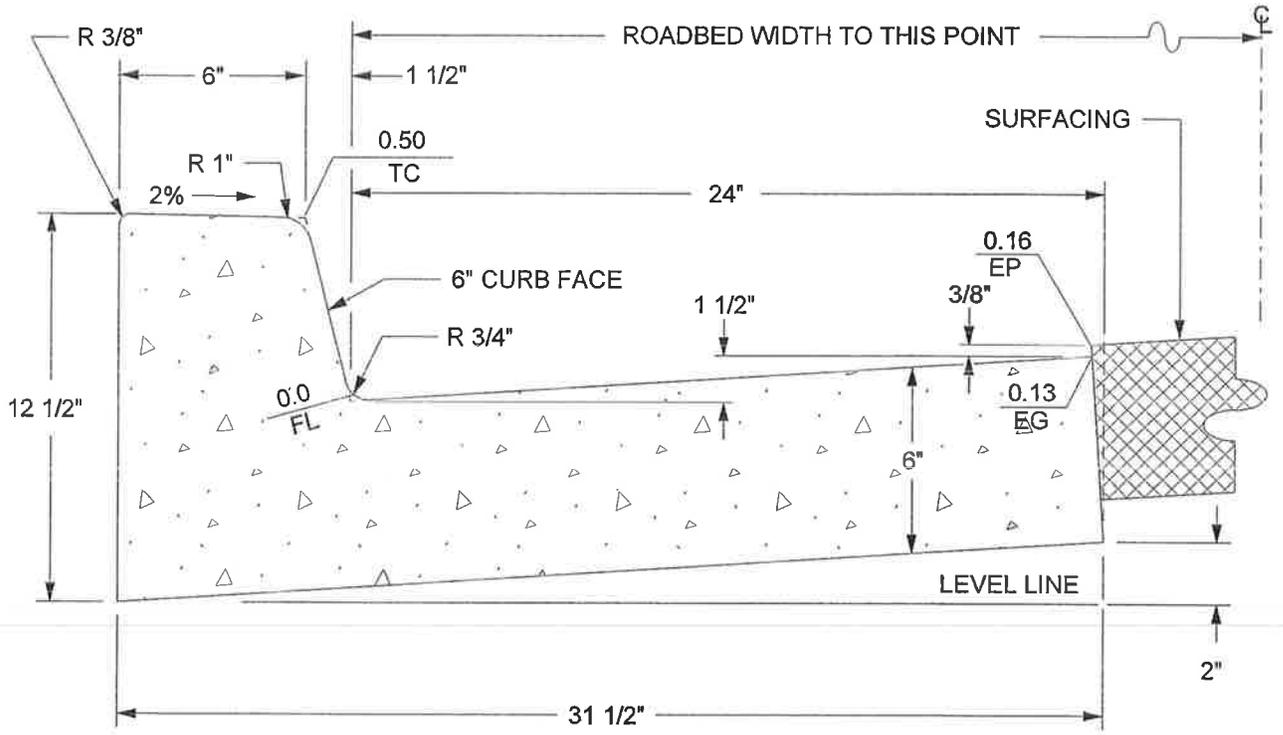

CLASS "B" CONCRETE
 1.601 CU. FT. / L.F.
 1 CU. YD. = 16.86 L.F.

ABBREVIATIONS:
 TC = TOP OF CURB
 FL = FLOWLINE
 EG = EDGE OF GUTTER
 EP = EDGE OF PAVEMENT

APPROVED BY:										COUNTY OF RIVERSIDE				
 DATE: 05/01/07 DIRECTOR OF TRANSPORTATION GEORGE A. JOHNSON, RCE 42328										TYPE A-6 CURB				
REVISIONS		REV.	BY:	APR'D	DATE	REV.	BY:	APR'D	DATE	STANDARD NO. 200				
8-71, 9-88		1				4								
2-90, 11-04		2				5								
		3				6								

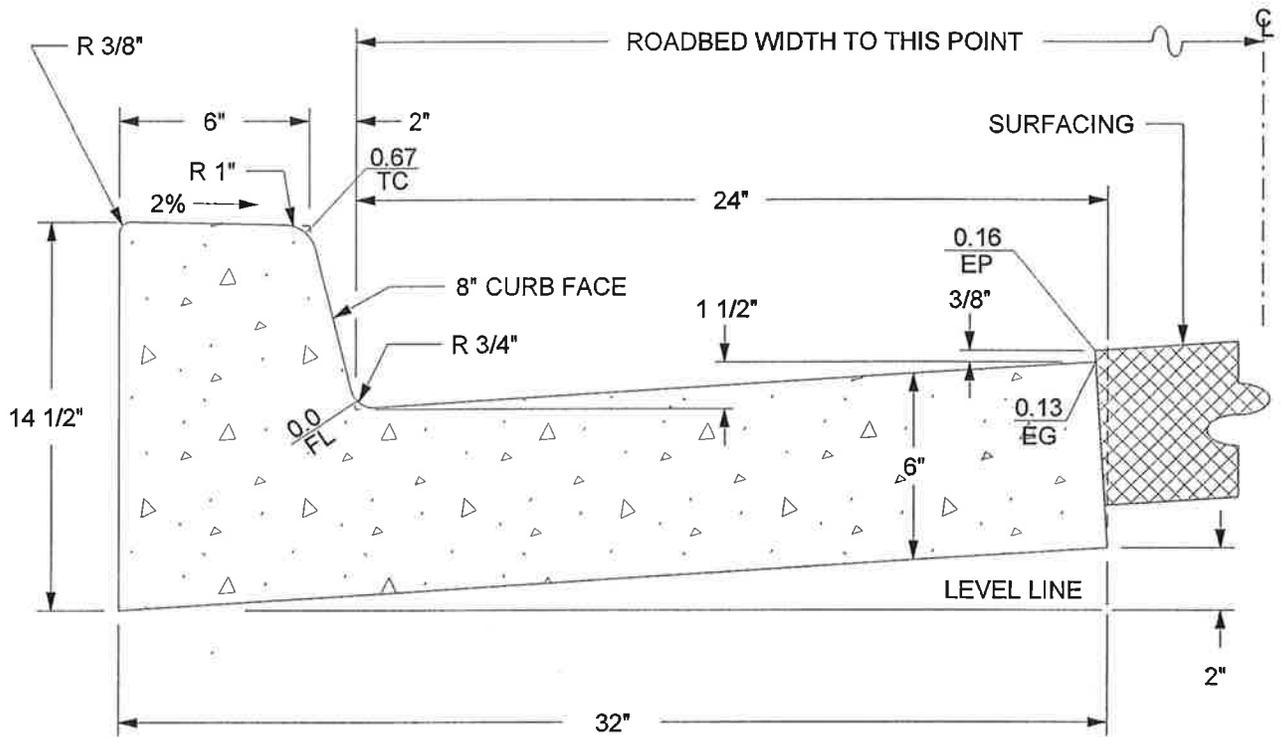

CLASS "B" CONCRETE

1.73 CU. FT. / L.F.

1 CU. YD. = 15.60 L.F.

ABBREVIATIONS:

TC = TOP OF CURB

FL = FLOWLINE

EG = EDGE OF GUTTER

EP = EDGE OF PAVEMENT

APPROVED BY:

George A. Johnson
 DIRECTOR OF TRANSPORTATION
 GEORGE A. JOHNSON, RCE 42328

DATE: 05/01/07



COUNTY OF RIVERSIDE

TYPE A-8 CURB

STANDARD NO. 201

REVISIONS		REV.	BY:	APR'D	DATE	REV.	BY:	APR'D	DATE
8-71, 9-88		1				4			
2-90, 11-04		2				5			
		3				6			

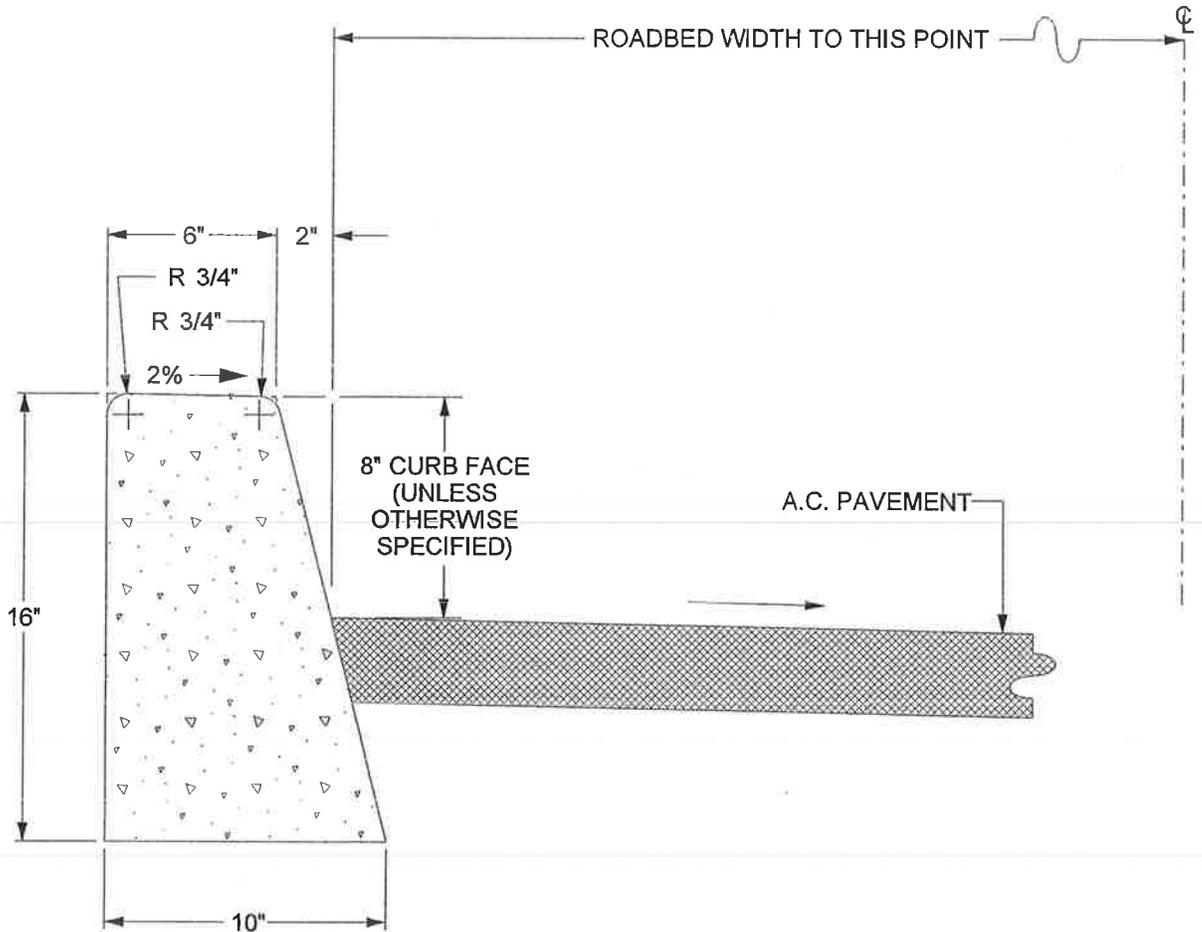

CLASS "B" CONCRETE

0.888 CU FT. / L.F.

1 CU. YD. = 30.41 L.F.

APPROVED BY:

George A. Johnson
 DIRECTOR OF TRANSPORTATION
 GEORGE A. JOHNSON, RCE 42328

DATE: 05/01/07



COUNTY OF RIVERSIDE

TYPE "D" CURB

REVISIONS	REV.	BY:	APR'D	DATE	REV.	BY:	APR'D	DATE
8-71, 2-90	1				4			
11-04	2				5			
	3				6			

STANDARD NO. 204

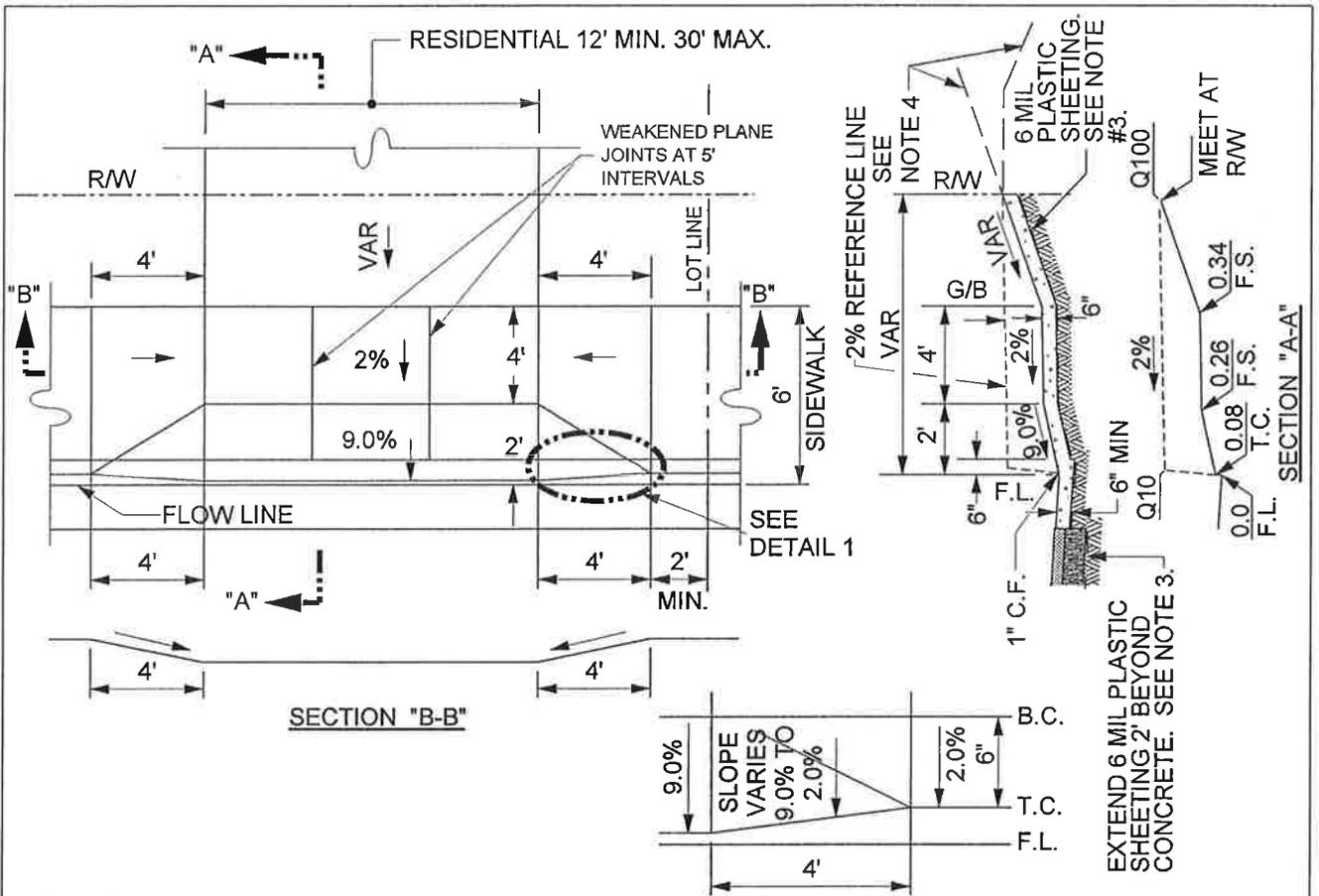

NOTES:

1. ALL CONSTRUCTION SHALL BE CLASS "3" CONCRETE.
2. 20' OF FULL-HEIGHT CURB REQUIRED BETWEEN DRIVEWAYS WITHIN ANY ONE PROPERTY FRONTAGE.
3. USE 6 MIL PLASTIC SHEETING WHEN ABUTTING SOIL HAS A HIGH SULFATE CONTENT, SPECIAL CONSIDERATIONS ARE REQUIRED. SEE SPECIFICATIONS (SECTION 16.04).
4. CONSTRUCT THE PROFILE GRADE OF THE PRIVATE ON-SITE DRIVEWAY SO THAT IT PROVIDES SMOOTH VEHICLE ACCESS OVER THE DRIVE APPROACH.

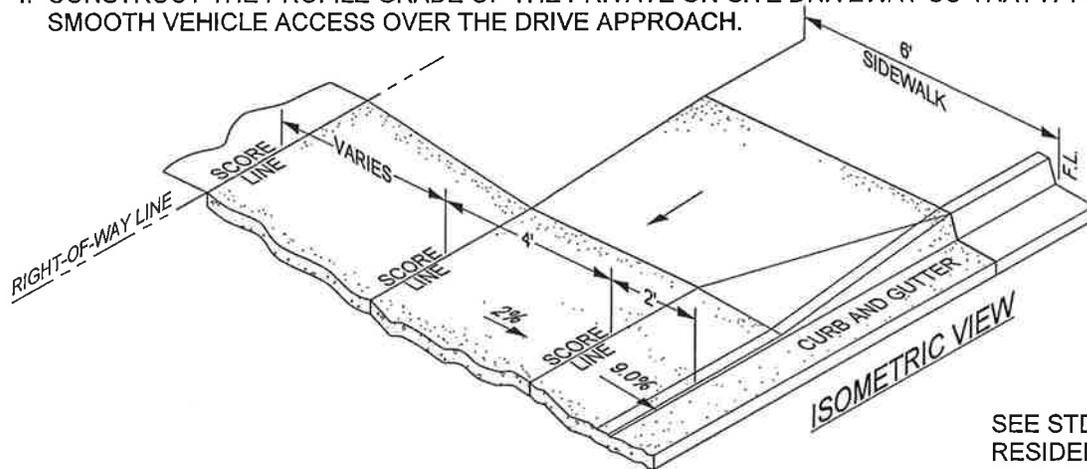

SEE STD NO. 213 FOR RESIDENTIAL DRIVEWAY WITH SIDEWALK AT RW

APPROVED BY:

George A. Johnson
 DIRECTOR OF TRANSPORTATION
 GEORGE A. JOHNSON, RCE 42328

DATE: 11/15/04



COUNTY OF RIVERSIDE

RESIDENTIAL DRIVEWAY WITH SIDEWALK AT CURB

REVISIONS		REV.	BY:	APR'D	DATE	REV.	BY:	APR'D	DATE
8-71, 8-77	11-04	1				4			
5-80, 2-82		2				5			
2-90, 12-97		3				6			

STANDARD NO. 207

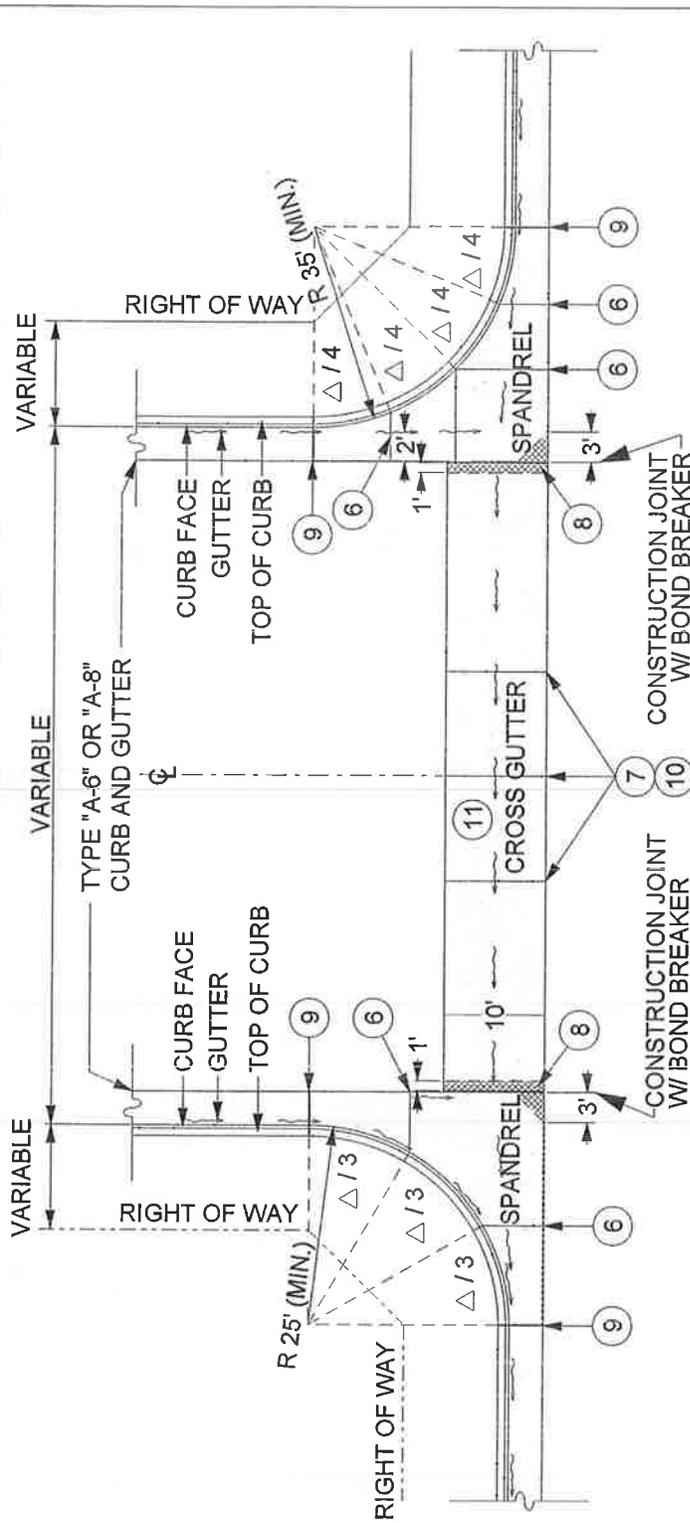

NOT TO SCALE

- 1 CROSS GUTTER FOR USE WITH TYPES "A-6" AND "A-8" CURB.
- 2 APRON THICKNESS TO BE 8" MINIMUM.
- 3 CROSS GUTTER THICKNESS TO BE 8" MINIMUM.
- 4 CLASS "A" CONCRETE.
- 5 PLACE MIN. 6" BASE UNDER ENTIRE SPANDREL AND CROSS GUTTER AREA.
- 6 WEAKENED PLANE JOINTS TO BE CONSTRUCTED AT 1/3 POINTS ON 25' RADIUS SPANDRELS, AND AT 1/4 POINTS ON 35' RADIUS SPANDRELS.
- 7 CONSTRUCT WEAKENED PLANE JOINT(S) PER STANDARD #205 AT MIDPOINT OF CROSS GUTTERS LESS THAN 40' LONG, OR AT 1/3 POINTS OF CROSS GUTTERS OF 40' OR LONGER.
- 8 THIS PORTION OF SPANDREL AND CROSS GUTTER SHALL BE CONSTRUCTED WITH 12 INCH THICK, CLASS "A" CONCRETE.
- 9 CONSTRUCT EXPANSION JOINT PER STANDARD # 205.
- 10 CONSTRUCT WEAKENED PLANE JOINT PER STANDARD # 205.
- 11 CONSTRUCT CROSS GUTTER PER TYPICAL SECTION ON SHEET 2.
- 12 WHEN ABUTTING SOIL HAS A HIGH SULFATE CONTENT, SPECIAL CONSIDERATIONS ARE REQUIRED. SEE SPECIFICATIONS (SECTION 16.04).

APPROVED BY:

George A. Johnson
 DIRECTOR OF TRANSPORTATION
 GEORGE A. JOHNSON, RCE 42328

DATE: 05/01/07



COUNTY OF RIVERSIDE

**CROSS GUTTER
(LAYOUT)**

STANDARD NO. 209 (1 OF 2)

REVISIONS		REV.	BY:	APR'D	DATE	REV.	BY:	APR'D	DATE
11-77, 8-82		1				4			
9-88, 2-90		2				5			
11-04		3				6			

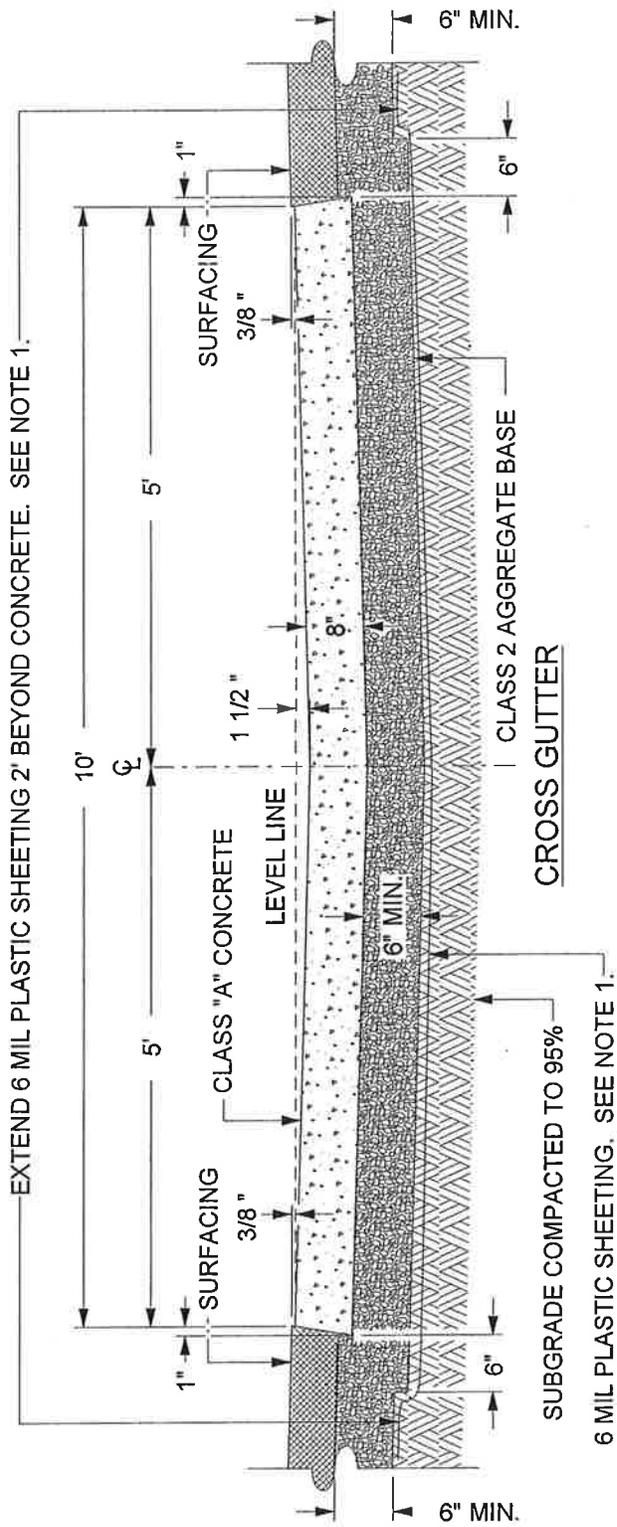

NOT TO SCALE

NOTE

1. WHEN ABUTTING SOIL HAS A HIGH SULFATE CONTENT, SPECIAL CONSIDERATIONS ARE REQUIRED. SEE SPECIFICATIONS (SECTION 16.04).

APPROVED BY:

George A. Johnson
 DIRECTOR OF TRANSPORTATION
 GEORGE A. JOHNSON, RCE 42328

DATE: 05/01/07



COUNTY OF RIVERSIDE

**CROSS GUTTER
 (TYPICAL SECTION)**

REVISIONS	REV.	BY:	APR'D	DATE	REV.	BY:	APR'D	DATE
8-71, 9-88	1				4			
2-90, 12-97	2				5			
11-04	3				6			

STANDARD NO. 209 (2 OF 2)

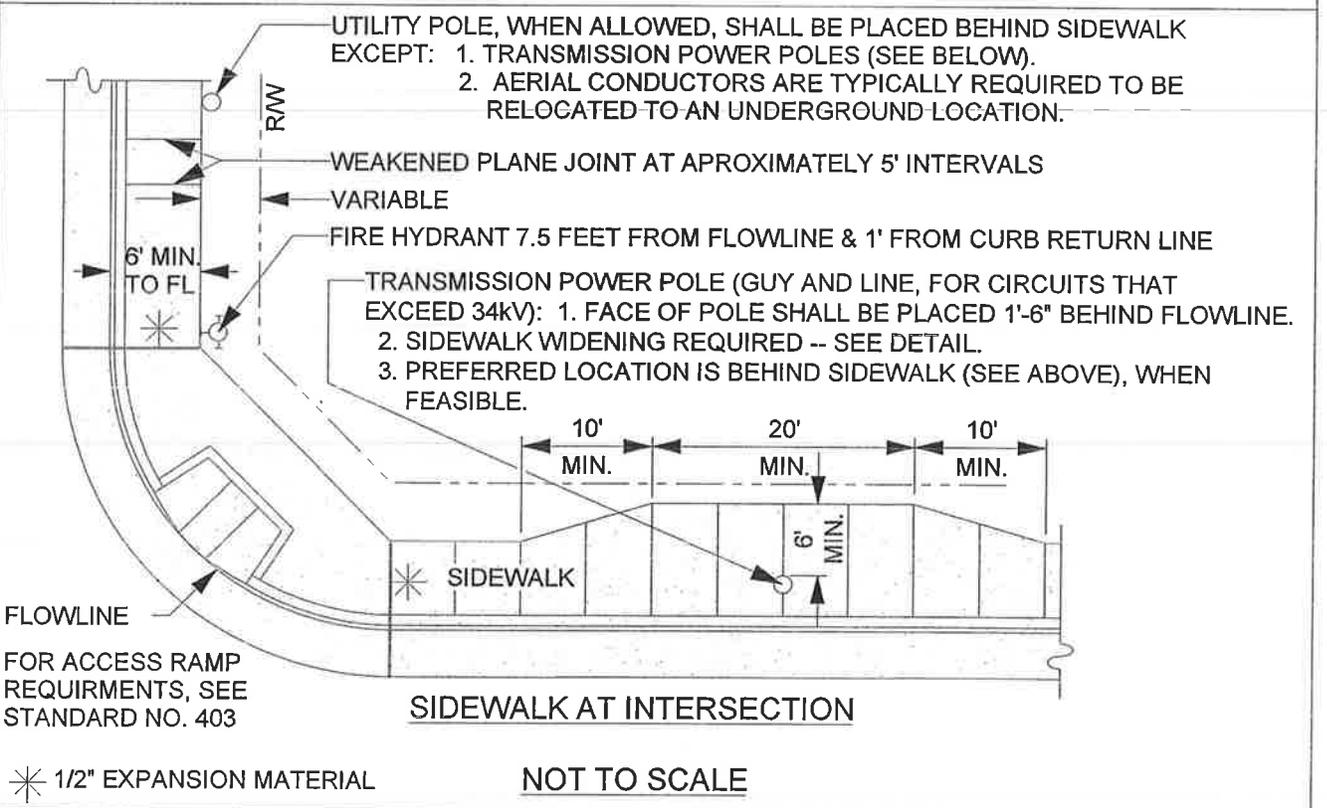
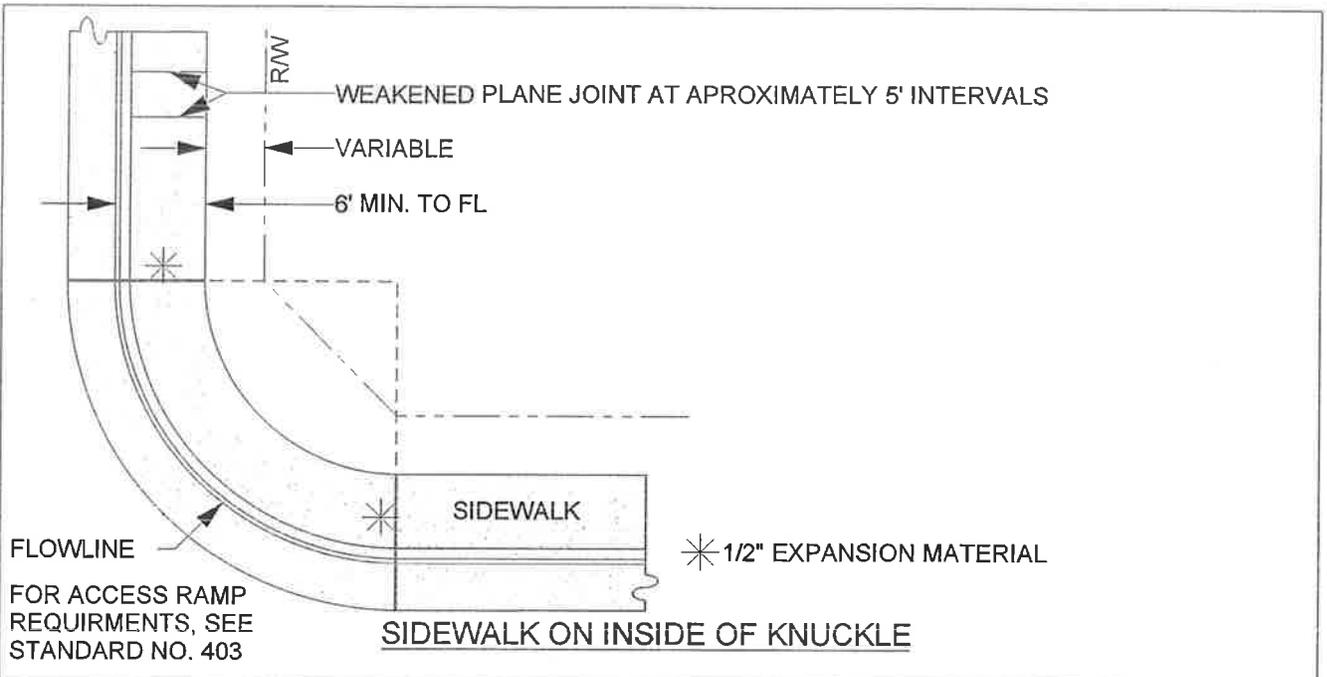

NOTE:

1. VARIABLE DISTANCES TO BE SHOWN ON APPLICABLE TYPICAL ROAD SECTION STANDARD.
2. CONSTRUCTION TO BE OF CLASS "B" CONCRETE 4" MINIMUM THICKNESS.

APPROVED BY:

George A. Johnson
 DIRECTOR OF TRANSPORTATION
 GEORGE A. JOHNSON, RCE 42328

DATE: 05/01/07

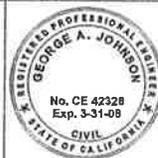

COUNTY OF RIVERSIDE

**SIDEWALK,
 FIRE HYDRANT, &
 UTILITY POLE LOCATION
 (SIDEWALK AT CURB)**

STANDARD NO. 400 (1 OF 2)

REVISIONS		REV.	BY:	APR'D	DATE	REV.	BY:	APR'D	DATE
8-71, 8-77		1				4			
11-77, 8-82		2				5			
9-88, 11-04		3				6			

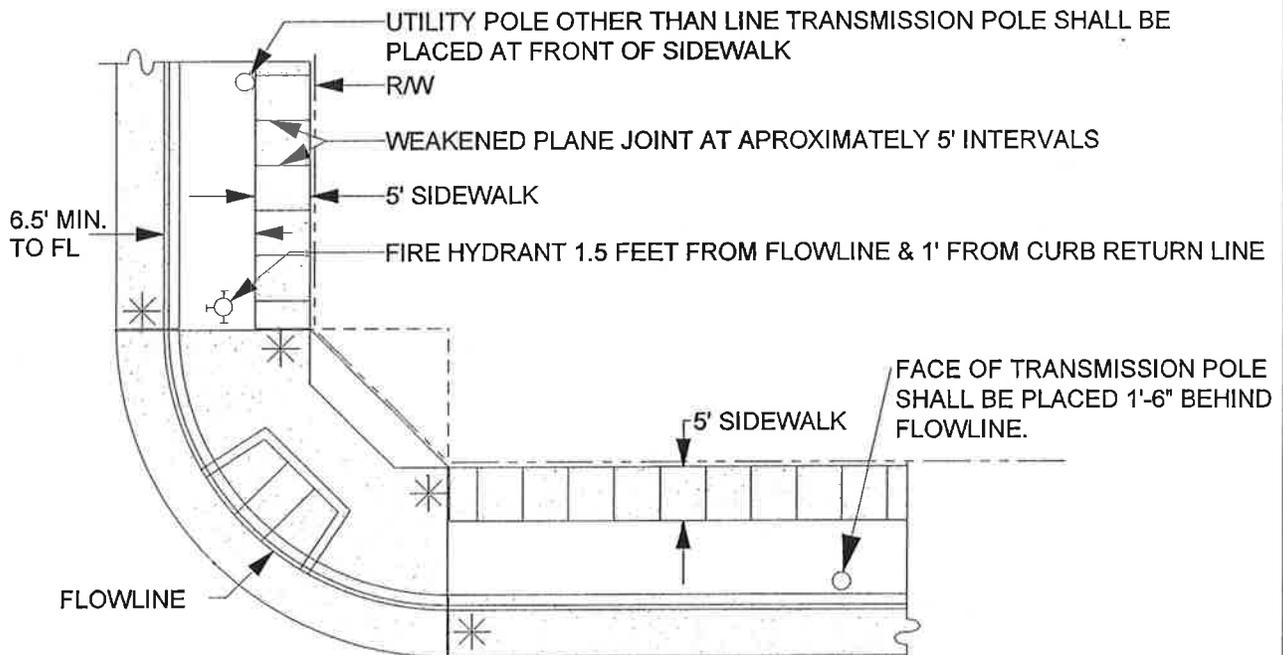
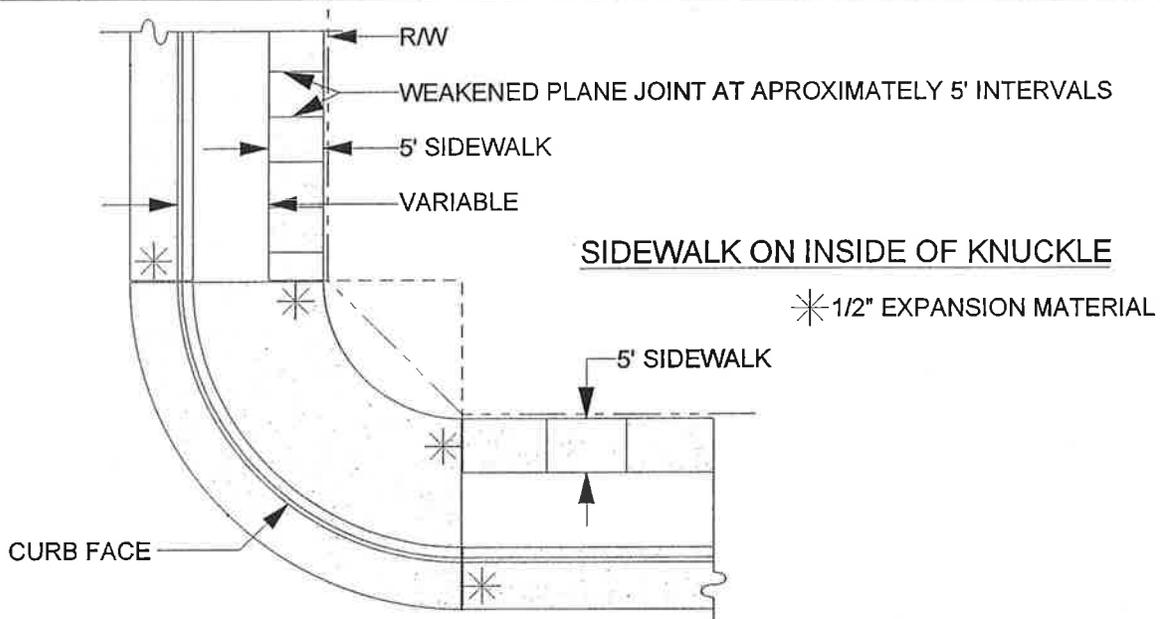

ACCESS RAMP REQUIREMENTS
SEE STANDARD NO.403

SIDEWALK
* 1/2" EXPANSION MATERIAL

NOT TO SCALE

NOTE:

1. VARIABLE DISTANCES TO BE SHOWN ON APPLICABLE TYPICAL ROAD SECTION STANDARD.
2. CONSTRUCTION TO BE OF CLASS "B" CONCRETE 4" MINIMUM THICKNESS.

APPROVED BY:

George A. Johnson
 DIRECTOR OF TRANSPORTATION
 GEORGE A. JOHNSON, RCE 42328

DATE: 05/01/07

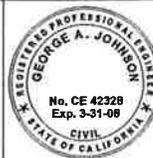

COUNTY OF RIVERSIDE

**SIDEWALK,
 FIRE HYDRANT, &
 UTILITY POLE LOCATION
 (SIDEWALK AT R/W)**

STANDARD NO. 400 (2 OF 2)

REVISIONS		REV.	BY:	APR'D	DATE	REV.	BY:	APR'D	DATE
8-71, 8-77	11-04	1				4			
11-77, 8-82		2				5			
9-88, 2-90		3				6			

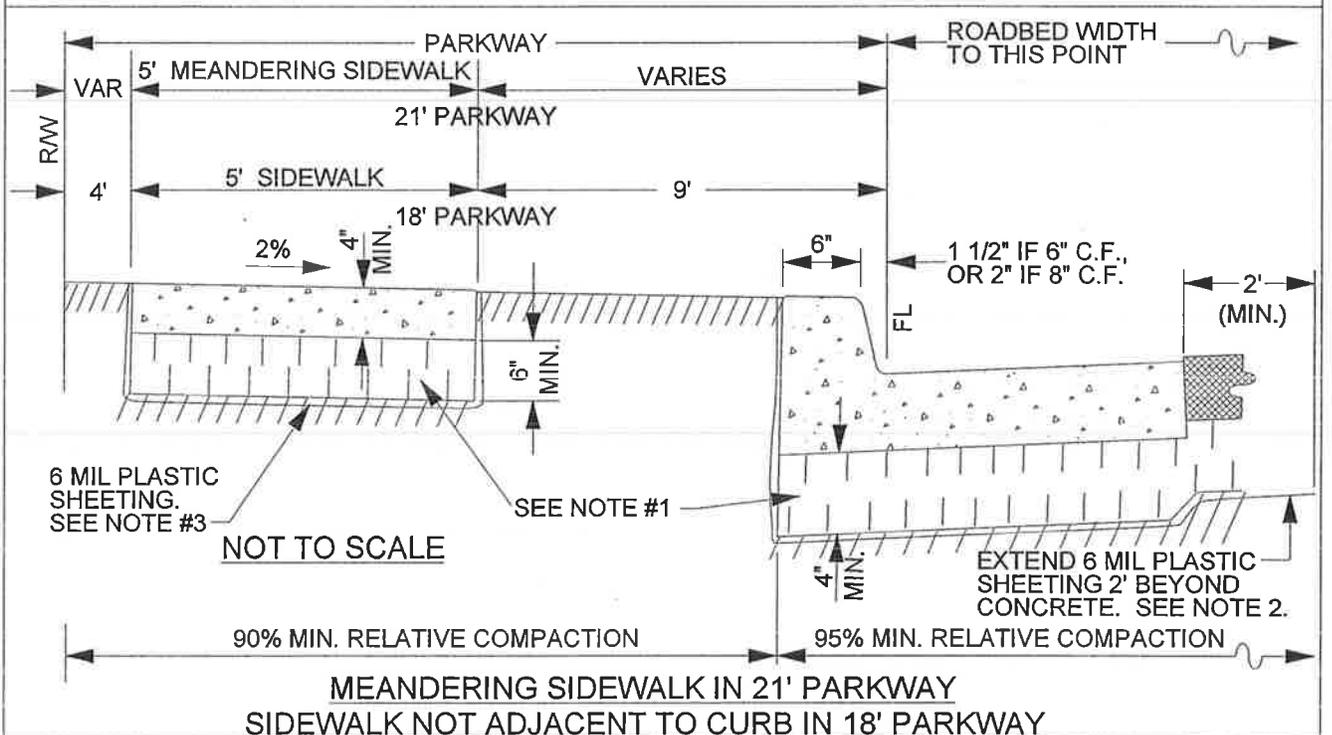
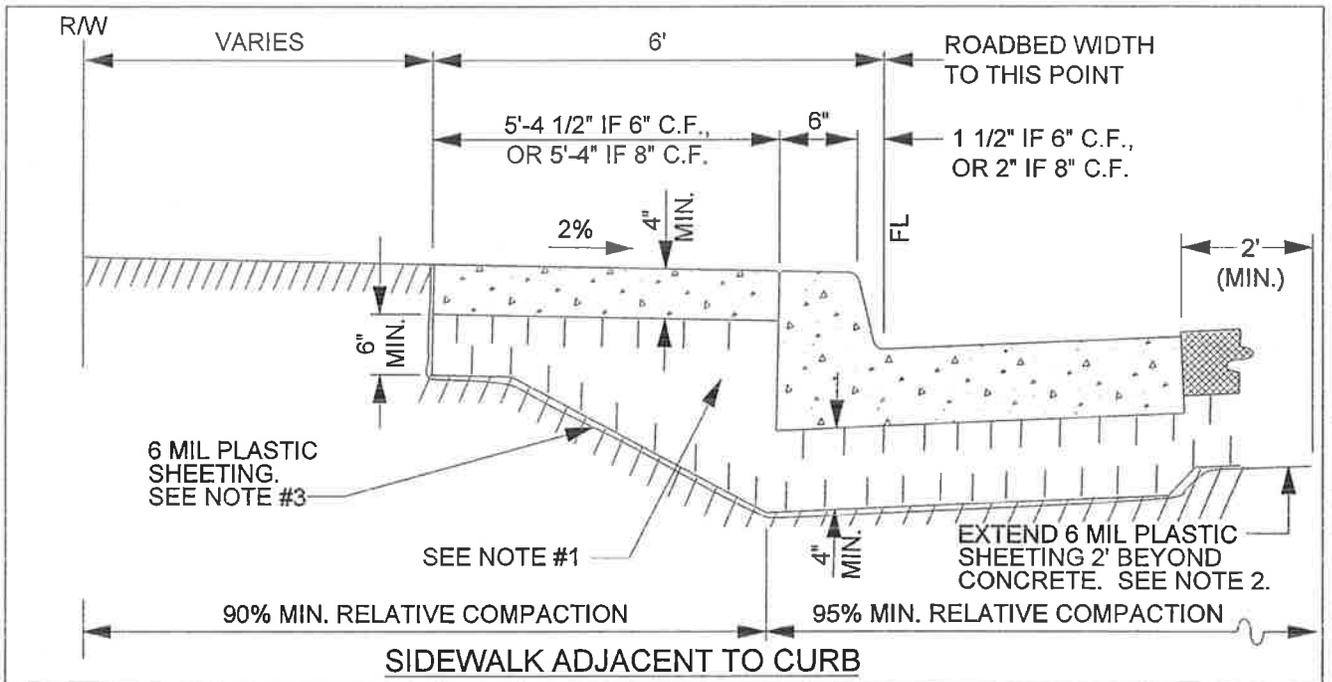

NOTE:

1. AGGREGATE BASE OR APPROVED SELECT MATERIAL WHEN SOILS REPORT INDICATES PRESENCE OF EXPANSIVE SOIL CONDITIONS.
2. ALL CONSTRUCTION SHALL BE CLASS "B" CONCRETE.
3. WHEN ABUTTING SOIL HAS A HIGH SULFATE CONTENT, SPECIAL CONSIDERATIONS ARE REQUIRED. SEE SPECIFICATIONS (SECTION 16.04).

APPROVED BY:

George A. Johnson DATE: 05/01/07

DIRECTOR OF TRANSPORTATION
GEORGE A. JOHNSON, RCE 42328



COUNTY OF RIVERSIDE

SIDEWALK AND CURB

REVISIONS	REV.	BY:	APR'D	DATE	REV.	BY:	APR'D	DATE
8-71, 11-77	1				4			
8-82, 9-88	2				5			
4-90, 11-04	3				6			

STANDARD NO. 401

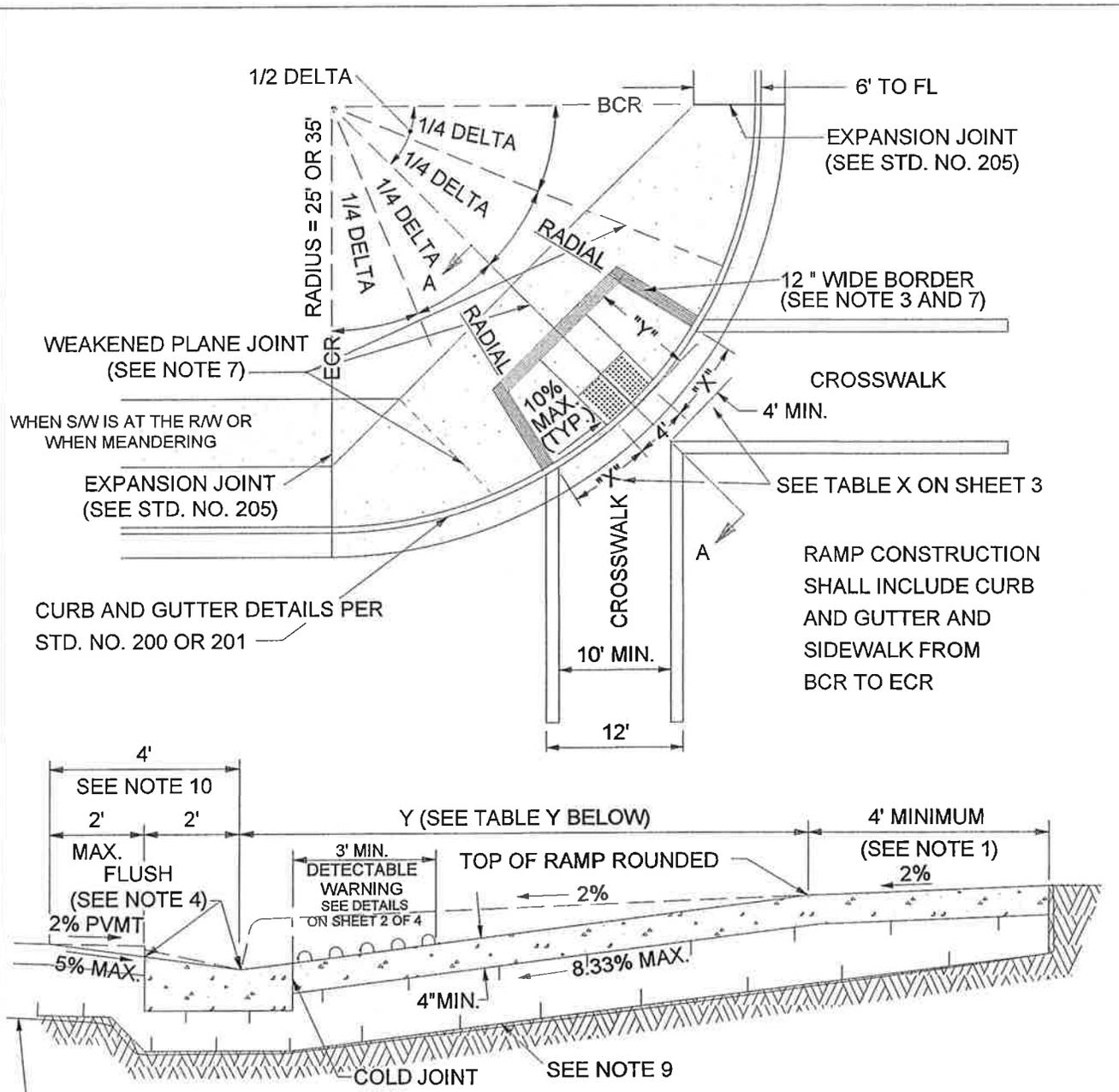

SECTION A-A



TABLE Y

CF	Y
6"	7.90'
8"	10.53'

$$Y = \frac{\text{CURB FACE (FT.)}}{6.33\%}$$

NOT TO SCALE

SEE SHEET 4 OF 4 FOR NOTES.

APPROVED BY:

 DATE: 11/15/04
 DIRECTOR OF TRANSPORTATION
 GEORGE A. JOHNSON, RCE 42328



COUNTY OF RIVERSIDE

**CURB RAMP
CASE A**

REVISIONS		REV.	BY:	APR'D	DATE	REV.	BY:	APR'D	DATE
8-77, 5-80	11-04	1				4			
10-81, 6-82		2				5			
9-88, 2-90		3				6			

STANDARD NO. 403 (1 OF 4)

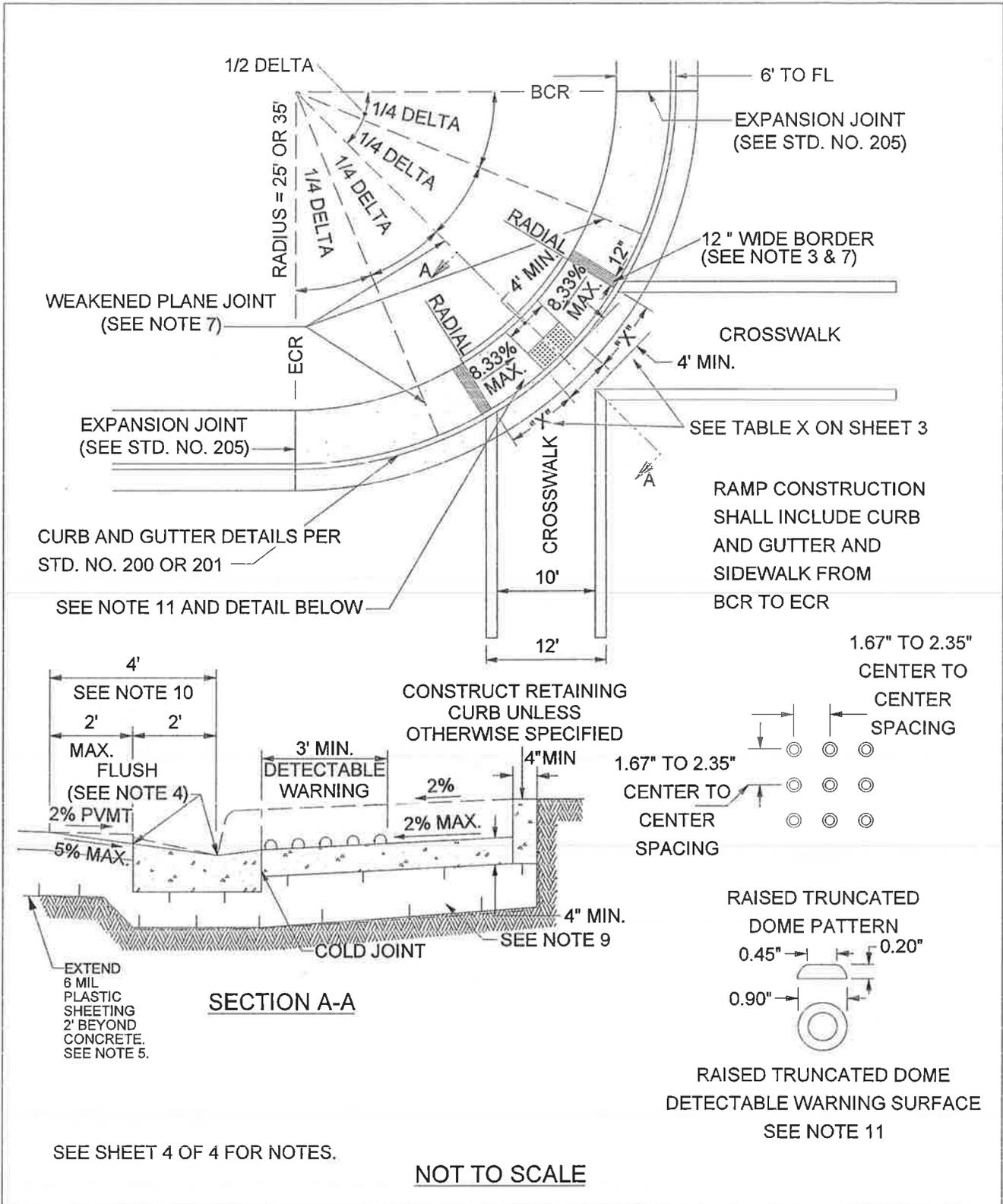

SEE SHEET 4 OF 4 FOR NOTES.

NOT TO SCALE

APPROVED BY:				COUNTY OF RIVERSIDE					
				<p align="center">CURB RAMP CASE B</p>					
DATE: 11/15/04 DIRECTOR OF TRANSPORTATION GEORGE A. JOHNSON, RCE 42328		STANDARD NO. 403 (2 OF 4)				12-97			
REVISIONS		REV.	BY:	APR'D	DATE	REV.	BY:	APR'D	DATE
8-77, 5-80	11-04	1				4			
10-81, 6-82		2				5			
9-88, 2-90		3				6			

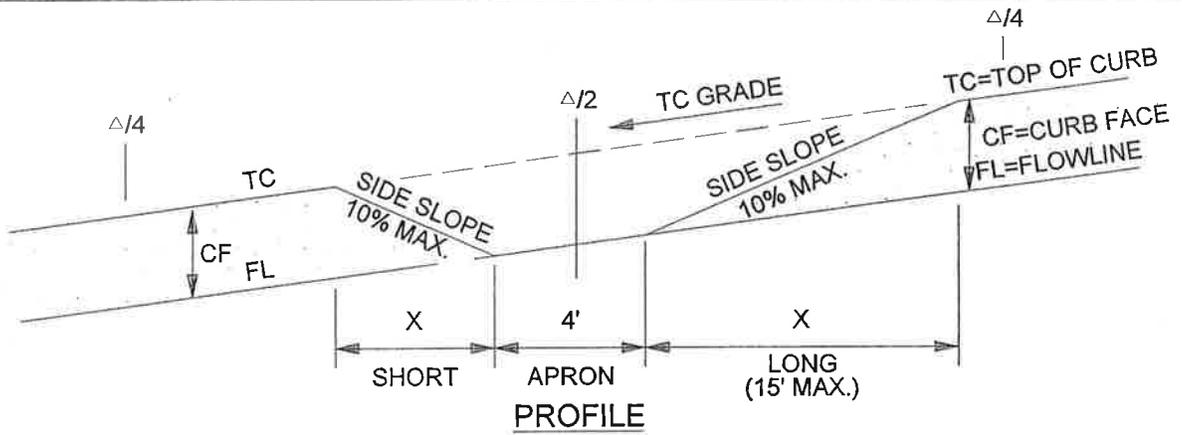

TABLE X

CF (IN)	RADIUS (FT)	SIDE SLOPE	X	TC GRADE (ALONG CURB RETURN)					
				1%	2%	3%	4%	5%	6%
6"	35'	10%	X _S	4.6	4.2	3.9	3.6	3.4	3.2
			X _L	5.6	6.3	7.2	8.4	10.0	12.5
8"	35'	10%	X _S	6.1	5.6	5.2	4.8	4.5	4.2
			X _L	7.5	8.4	9.6	11.2	13.4	15.0

TO CALCULATE "X" DIMENSION:

SHORT SIDE (DOWN SLOPE): $X_S (FT) = \frac{\text{CURB FACE (FT)}}{\text{SIDE SLOPE} + \text{TC GRADE}}$

LONG SIDE (UP SLOPE): $X_L (FT) = \frac{\text{CURB FACE (FT)}}{\text{SIDE SLOPE} - \text{TC GRADE}}$

ENGINEER TO SHOW X_S AND X_L ON IMPROVEMENT PLANS

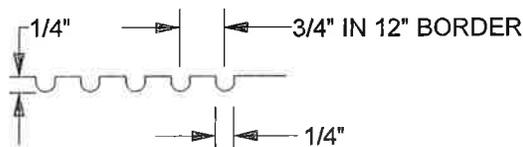

GROOVING DETAIL

APPROVED BY:

George A. Johnson
 DIRECTOR OF TRANSPORTATION
 GEORGE A. JOHNSON, RCE 42328

DATE: 05/05/07



COUNTY OF RIVERSIDE

CURB RAMP

REVISIONS		REV.	BY:	APR'D	DATE	REV.	BY:	APR'D	DATE
8-77, 5-80	11-04	1				4			
10-81, 6-82		2				5			
9-88, 2-90		3				6			

STANDARD NO. 403 (3 OF 4)

CONSTRUCTION NOTES:

1. IF DISTANCE FROM CURB TO BACK OF SIDEWALK IS TOO SHORT TO ACCOMODATE RAMP AND 4' LANDING, THEN USE THE CASE "B" RAMP.
2. IF SIDEWALK IS LESS THAN 6' WIDE, THE FULL WIDTH OF THE SIDEWALK SHALL BE DEPRESSED AS SHOWN IN CASE B. MINIMUM SIDEWALK WIDTH IS 4' FROM BACK OF CURB.
3. THE RAMP SHALL HAVE A 12" WIDE BORDER WITH GROOVES 1/4" WIDE AND 1/4" DEEP APPROXIMATELY 3/4" ON CENTER. SEE GROOVING DETAIL.
4. TRANSITIONS FROM RAMPS TO WALKS, GUTTERS, OR STREETS SHALL BE FLUSH AND FREE OF ABRUPT CHANGES.
5. WHEN ABUTTING SOIL HAS A HIGH SULFATE CONTENT, SPECIAL CONSIDERATIONS ARE REQUIRED. SEE SPECIFICATIONS (SECTION 16.04).
6. RAMP SIDE SLOPE VARIES UNIFORMLY FROM A MAXIMUM OF UP TO 10% AT CURB TO CONFORM WITH LONGITUDINAL SIDEWALK SLOPE ADJACENT TO TOP OF THE RAMP (EXCEPT IN CASE B).
7. CONSTRUCT WEAKENED PLANE JOINTS AT 1/4 DELTAS WHEN RADIUS EQUALS 35' AND AT INSIDE EDGE OF GROOVED BORDER WHEN RADIUS EQUALS 25'.
8. IF EXPANSIVE SOIL IS ENCOUNTERED, THEN RAMP SHALL BE CONSTRUCTED OVER CLASS 2 AGGREGATE MATERIAL.
9. CONCRETE SHALL BE CLASS B.
10. MAXIMUM SLOPES OF ADJOINING GUTTERS: THE ROAD SURFACE IMMEDIATELY ADJACENT TO THE CURB RAMP AND CONTINUOUS PASSAGE TO THE CURB RAMP SHALL NOT EXCEED 5% WITHIN 4' OF THE BOTTOM OF THE CURB RAMP.
11. DETECTABLE WARNING SURFACES ARE REQUIRED ON ALL CURB RAMPS THAT ENTER INTO A VEHICULAR TRAVEL WAY.

APPROVED BY:

George A. Johnson
 DIRECTOR OF TRANSPORTATION
 GEORGE A. JOHNSON, RCE 42328

DATE: 11/15/04



COUNTY OF RIVERSIDE

**CURB RAMP
 CONSTRUCTION NOTES**

REVISIONS		REV.	BY:	APR'D	DATE	REV.	BY:	APR'D	DATE
8-77, 5-80	11-04	1				4			
10-81, 6-82		2				5			
9-88, 2-90		3				6			

12-97

STANDARD NO. 403 (4 OF 4)

DIST COUNTY ROUTE POST MILES TOTAL PROJECT SHEET TOTAL NO. SHEETS

David E. Jones
REGISTERED CIVIL ENGINEER

Professional Engineer License # 47000
David E. Jones
June 23, 2006
Exp. 3-31-07
Title

DATE: May 1, 2006
PLANS APPROVAL DATE: _____
DESIGNED BY: _____
CHECKED BY: _____
IN CHARGE: _____
FOR THE COMPLETION OF THE PROJECT, THE CONTRACTOR SHALL BE RESPONSIBLE FOR THE ACCURACY OF THE INFORMATION AND DATA PROVIDED TO THE ENGINEER AND FOR THE COMPLETION OF ALL NECESSARY PERMITS AND APPROVALS.

To refer to the Contract and S&C, go to: <http://www.dot.ca.gov>

NO PASSING ZONES-TWO DIRECTION

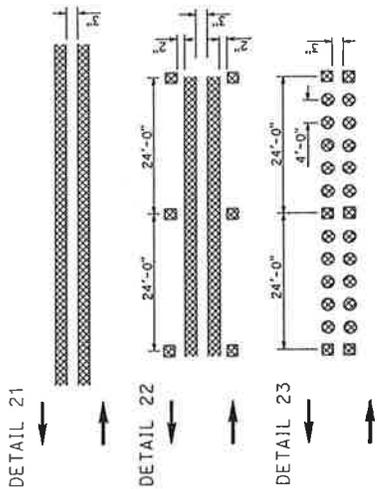

TYPICAL LANE LINE DELINEATION
IN ADVANCE OF EXIT RAMP

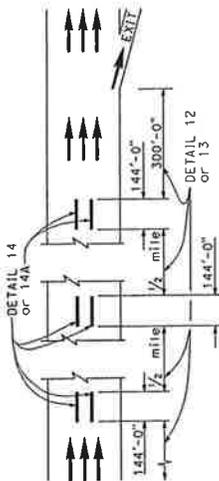

NOTE:
Detail 14 is to be used in combination with Detail 13. Detail 14A is to be used in combination with Detail 12.

LEGEND
MARKERS

- TYPE A White Non-reflective
- TYPE AY Yellow Non-reflective
- TYPE C Red-clear Retroreflective
- ▨ TYPE D Two-way Yellow Retroreflective
- ▨ TYPE G One-way Clear Retroreflective
- ▨ TYPE H One-way Yellow Retroreflective

LINES

- ▬ 4" White
 - ▬ 4" Yellow
- Direction of Travel

MARKER DETAILS



TYPE A & TYPE AY

TYPE C & TYPE D

TYPE G & TYPE H



Retroreflective Face

LANELINES (CONT)

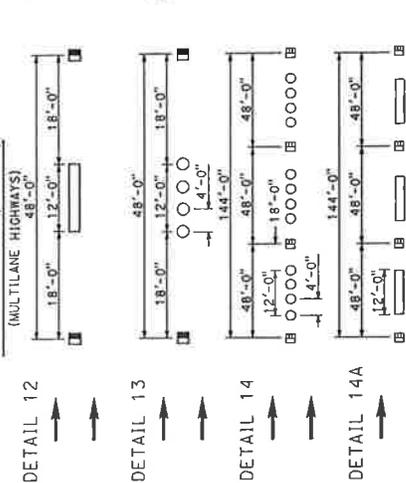

NO PASSING ZONES-ONE DIRECTION

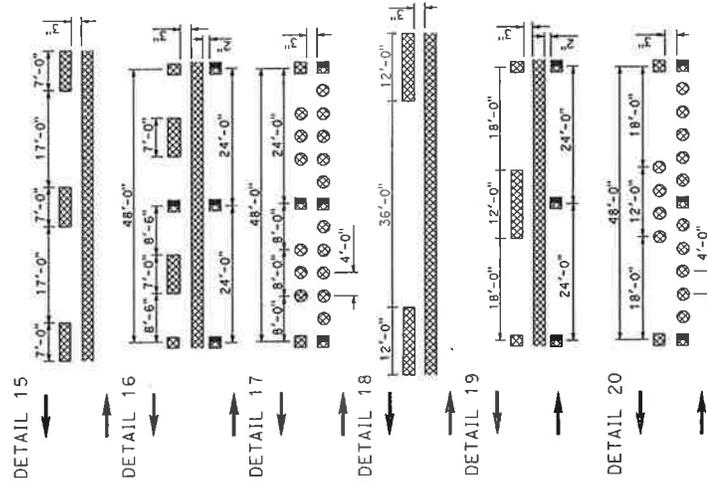

CENTERLINES
(2 LANE HIGHWAYS)

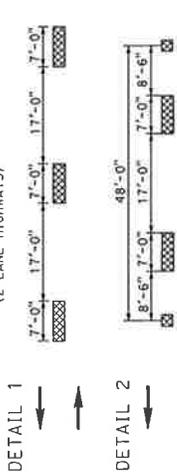

Detail 3 deleted

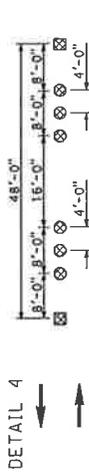

LANELINES
(MULTILANE HIGHWAYS)

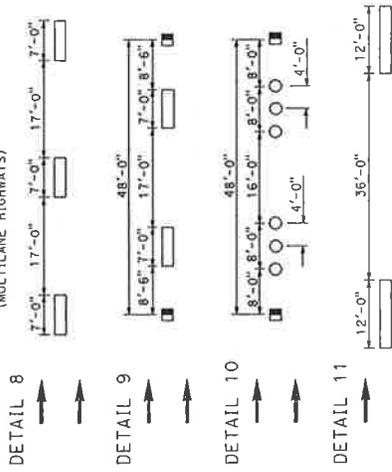

POST MILE	SHEET NO.	TOTAL SHEETS
ROUTE		
COUNTY		

REGISTERED CIVIL ENGINEER
 Donald E. Fisher
 No. 11,205
 State of California
 DIVISION OF HIGHWAYS
 1200 N. STREETS
 SACRAMENTO, CALIF. 95833

APPROVAL DATE: MAY 1, 2006
 The State of California, by its officers or employees, does not warrant the accuracy or completeness of electronic copies of this plan.

To get to the Caltrans web site, go to: <http://nlsr/caltrans.gov>

INTERSECTION TREATMENTS

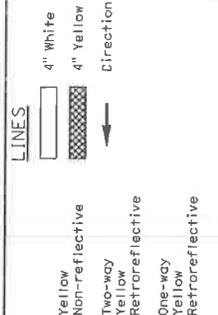

LEGEND

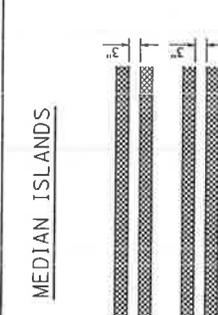

MEDIAN ISLANDS

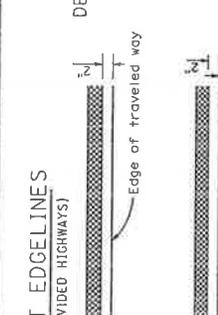

LEFT EDGELINES (DIVIDED HIGHWAYS)



RIGHT EDGELINES

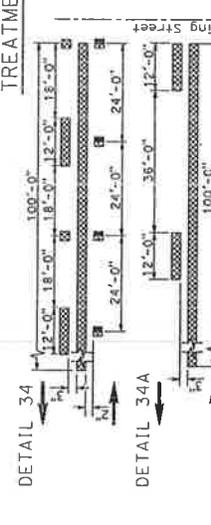

RIGHT EDGELINE EXTENSION THROUGH INTERSECTIONS

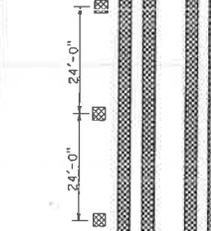

TWO-WAY LEFT TURN LANES

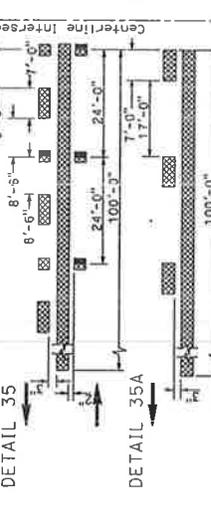

MARKER DETAILS

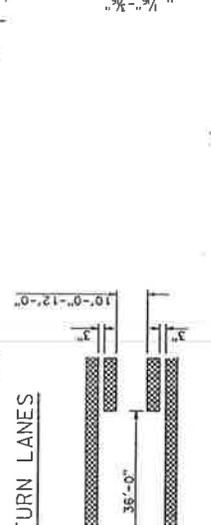

RETROREFLECTIVE FACE

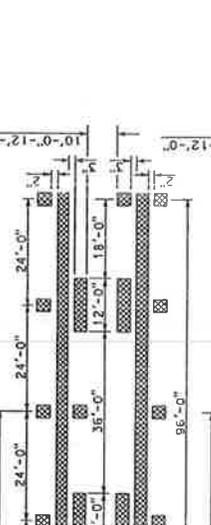

PAVEMENT MARKERS AND TRAFFIC LINES TYPICAL DETAILS

STATE OF CALIFORNIA
 DEPARTMENT OF TRANSPORTATION

NO SCALE

DIST COUNTY ROUTE SHEET TITLE SHEET NO. SHEETS
 REGISTERED CIVIL ENGINEER
 May 1, 2006
 PROFESSIONAL ENGINEER IN CALIFORNIA
 License No. CE6802
 Exp. 3-31-07
 The design and construction of this project is the responsibility of the engineer of record.
 The contractor shall be responsible for the accuracy of the electronic copies of this plan.
 To get the Callouts web site, go to: <http://www.fdot.com>

EXIT RAMP NEUTRAL AREA (GORE) TREATMENT

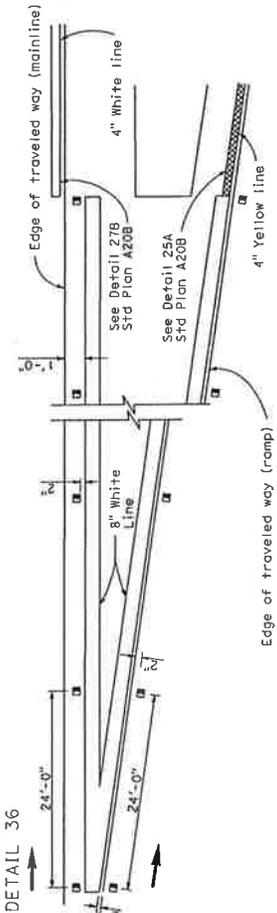

ENTRANCE RAMP NEUTRAL AREA (MERGE) TREATMENT

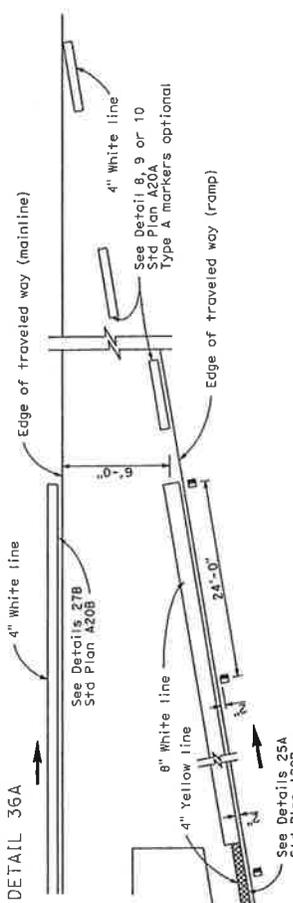

ENTRANCE RAMP NEUTRAL AREA (ACCELERATION LANE) TREATMENT

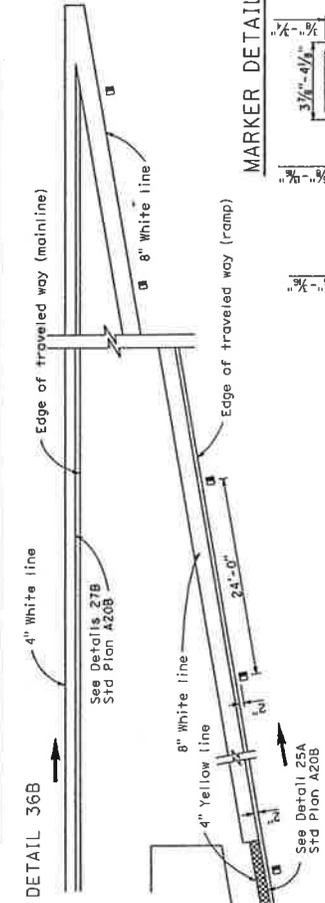

LANE DROP AT EXIT RAMP

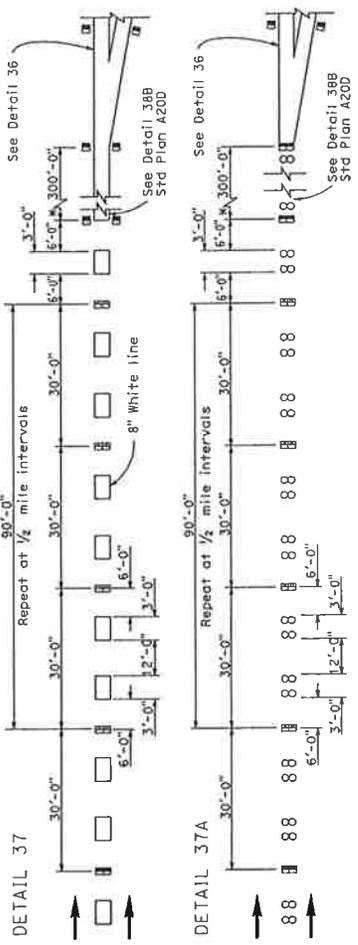

* The solid channelizing line shown may be omitted on short auxiliary lanes where weaving length is critical.

LANE DROP AT INTERSECTIONS

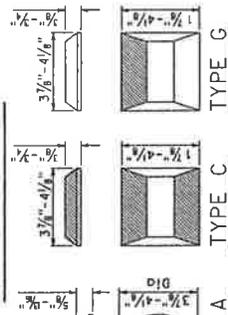
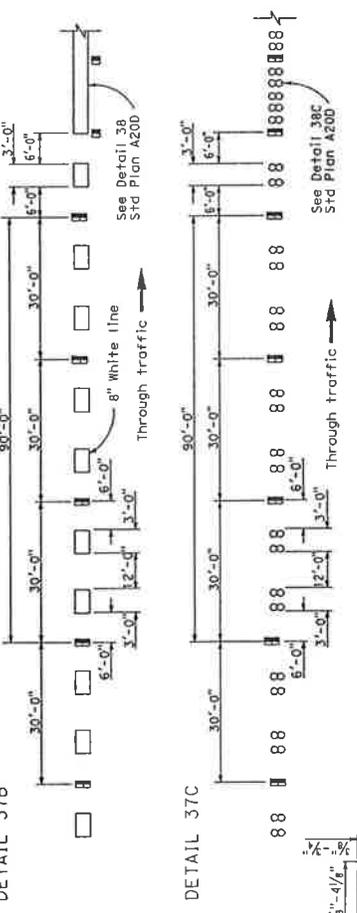

- LEGEND**
- MARKERS**
 ○ TYPE A White Non-reflective
 □ TYPE C Red-clear Retroreflective
 ■ TYPE G One-way Clear Retroreflective
- ← Direction of Travel
 ■ Retroreflective Face

STATE OF CALIFORNIA
 DEPARTMENT OF TRANSPORTATION
**PAVEMENT MARKERS
 AND TRAFFIC LINE
 TYPICAL DETAILS**

NO SCALE

DIST.	COUNTY	ROUTE	POST MILES	SHEET TOTAL
			TOTAL PROJECT	NO. SHEETS

REGISTERED CIVIL ENGINEER
Donald E. Howe
 No. C 45432
 Exp. 3-31-07
 STATE OF CALIFORNIA
 REGISTERED CIVIL ENGINEER

May 1, 2006
 PLANS APPROVAL DATE
 The State of California, the Office of
 Highway Materials and Transportation for the Highway
 Department, hereby certifies that the above
 drawings were prepared by the person
 named above.

To get to the Caltrans web site, go to <http://www.dot.ca.gov>

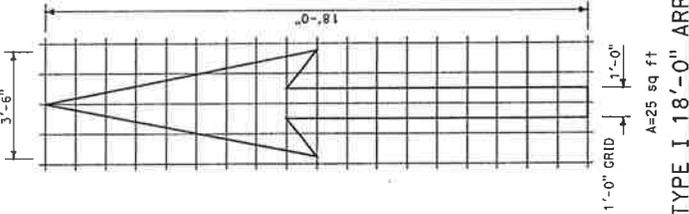
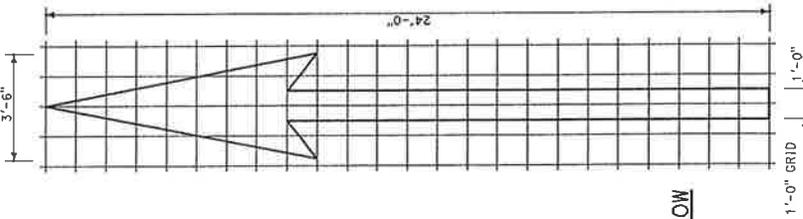
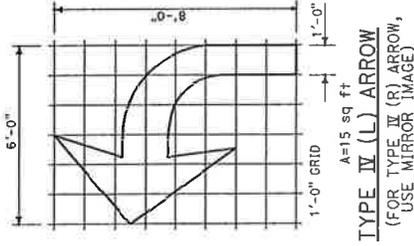
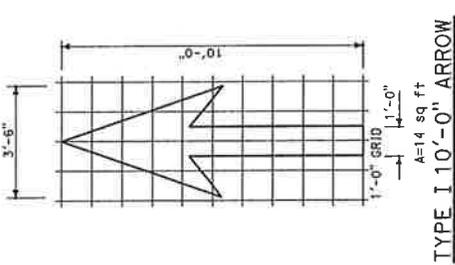
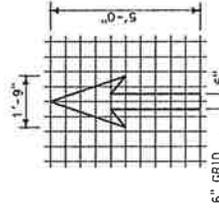
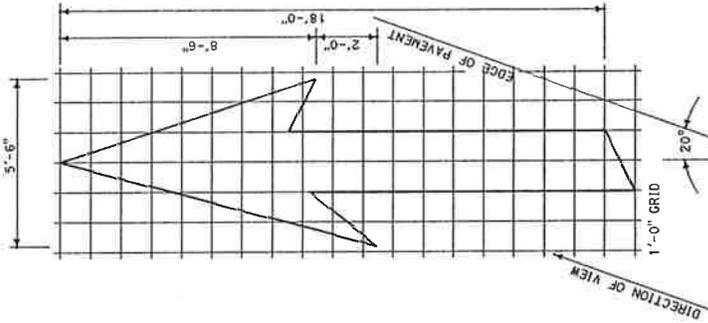
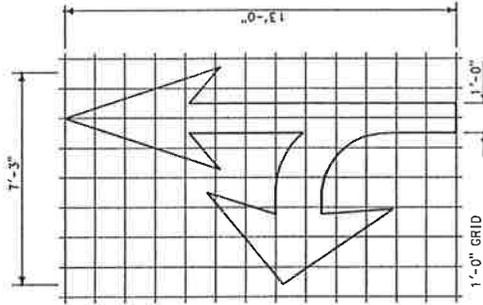
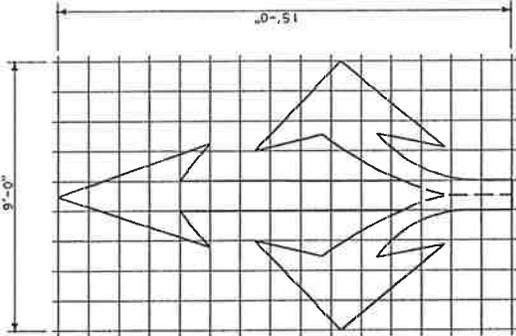

NOTE:
 MINOR VARIATIONS IN DIMENSIONS
 MAY BE ACCEPTED BY THE ENGINEER.

STATE OF CALIFORNIA
 DEPARTMENT OF TRANSPORTATION
**PAVEMENT MARKINGS
 ARROWS**
 NO SCALE

DIST	COUNTY	ROUTE	POST MILES	SHEET	TOTAL SHEETS



 DONALD E. ZBAR
 REGISTERED CIVIL ENGINEER
 NO. 10510
 EXPIRES 12/31/07
 CIVIL

MAY 1, 2006
 PLANS APPROVAL DATE
 The State of California or its officers or employees shall not be held liable for any errors or omissions in this plan.

To get to the Caltrans web site, go to <http://wwwdot.ca.gov>

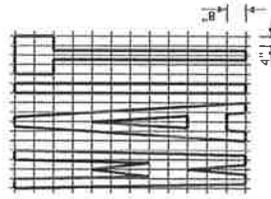

A=19 sq ft

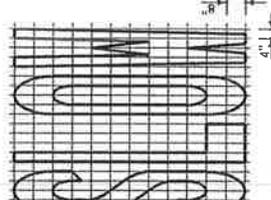

A=23 sq ft

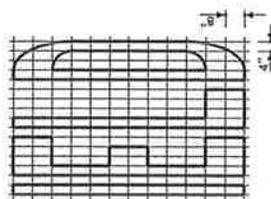

A=24 sq ft



A=42 sq ft

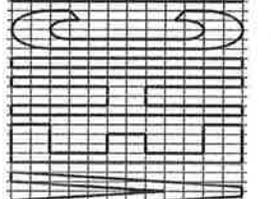

A=31 sq ft

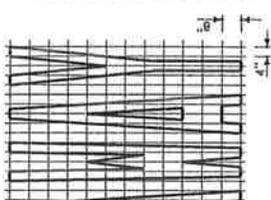

A=43 sq ft

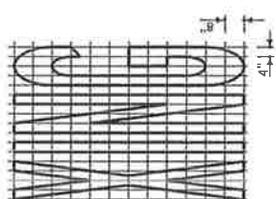

A=21 sq ft

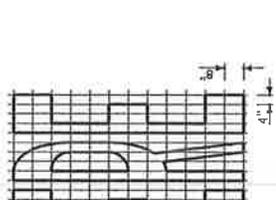

A=26 sq ft

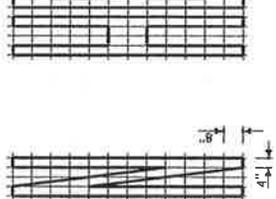

A=24 sq ft

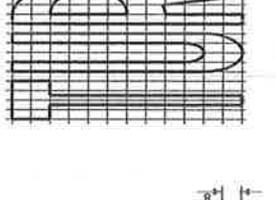

A=19 sq ft

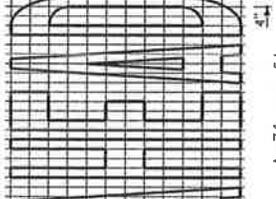

A=32 sq ft

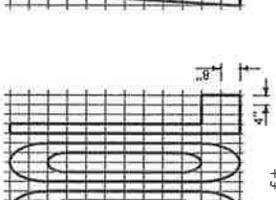

A=35 sq ft

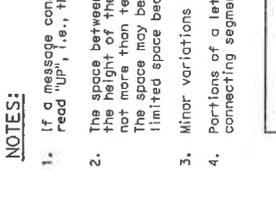

A=18 sq ft

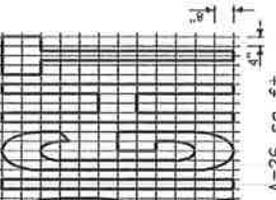

A=22 sq ft

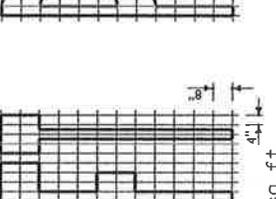

A=10 sq ft

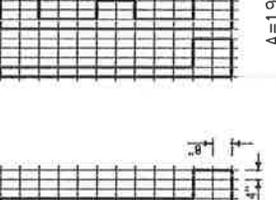

A=6 sq ft

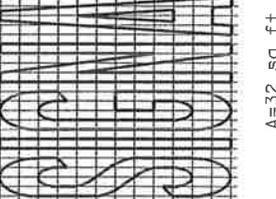

A=19 sq ft

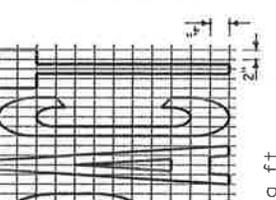

A=22 sq ft

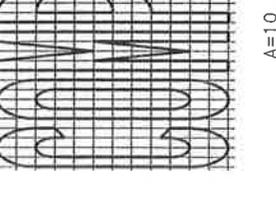

A=26 sq ft

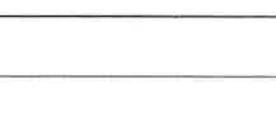

A=26 sq ft

NOTES:

- If a message consists of more than one word, it should read "up", i.e., the first word should be nearest the driver.
- The space between words should be at least four times the height of the characters for low speed roads, but not more than ten times the height of the characters. The space may be reduced appropriately where there is limited space because of local conditions.
- Minor variations in dimensions may be accepted by the Engineer.
- Portions of a letter, number or symbol may be separated by connecting segments not to exceed 2' in width.

WORD MARKINGS			
ITEM	sq ft	ITEM	sq ft
XING	21	YIELD	24
AHEAD	31	SCHOOL	35
WAIT	19	SIGNAL	32
LANE	6	TURN	24
RIGHT	26	HERE	26
		BIKE	5
		SLOW	23
		STOP	22
		LEFT	19
		VEHICLES	42
		COMPACT	18
		RUNWAY	43

STATE OF CALIFORNIA
DEPARTMENT OF TRANSPORTATION

**PAVEMENT MARKINGS
WORDS**

NO SCALE

A 24D

DIST	COUNTY	ROUTE	POST MILES	SHEET TOTAL
			TOTAL PROJECT	NO. SHEETS

REGISTERED CIVIL ENGINEER
 May 1, 2006
 PLANS APPROVAL DATE
 I hereby certify that the design and construction of the project shown on these plans and on the sheets hereof are in accordance with the requirements of applicable codes of this state and the laws of this state.

To get to the Collins web site, go to <http://www.dmagr.com>

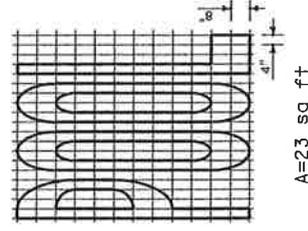
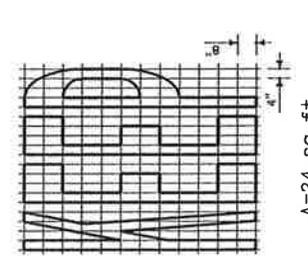
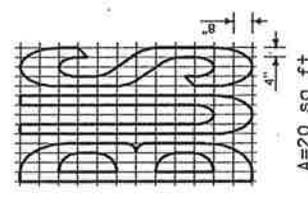
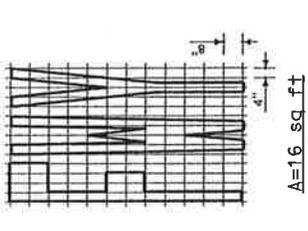
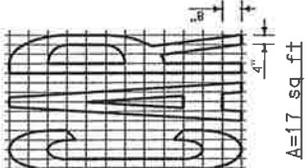
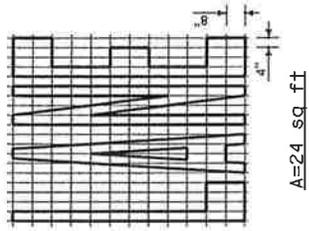
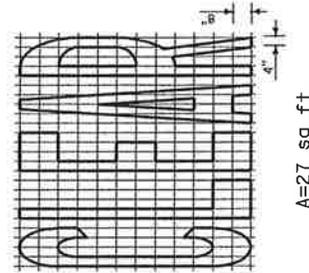
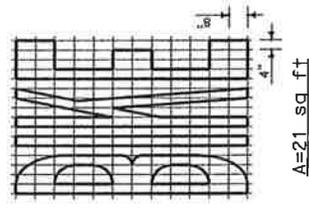
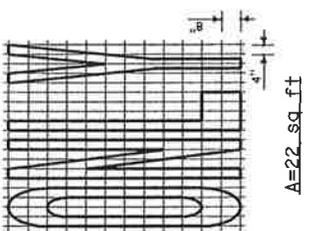
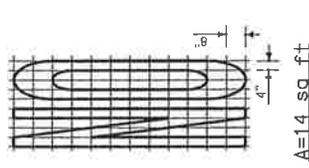

WORD MARKINGS			
ITEM	sq. ft.	ITEM	sq. ft.
LANE	24	NO	14
POOL	23	BIKE	21
CAR	17	BUS	20
CLEAR	27	ONLY	22
KEEP	24	FWY	15

NOTES:

1. If a message consists of more than one word, it should read "up", i.e., the first word should be nearest the driver.
2. The space between words should be at least four times the height of the characters on low speed roads, but not more than ten times the height of the characters on high speed roads, depending on the road appropriately where there is limited space because of local conditions.
3. Minor variations in dimensions may be accepted by the Engineer.
4. Portions of a letter, number or symbol may be separated by connecting segments not to exceed 2" in width.
5. Crosswalks contiguous to school grounds are to be 1'-0" yellow lines in place of 1'-0" white shown.
6. The words "NO PARKING" pavement marking is to be used for parking for 11 hrs. For typical locations of markings, see Standard Plans A304 and A305.
7. The words "NO PARKING", shall be painted in white letters no less than 1'-0" high on a contrasting background and located so that it is visible to traffic enforcement officials.



CROSSWALK AND LIMIT LINE

See Note 5

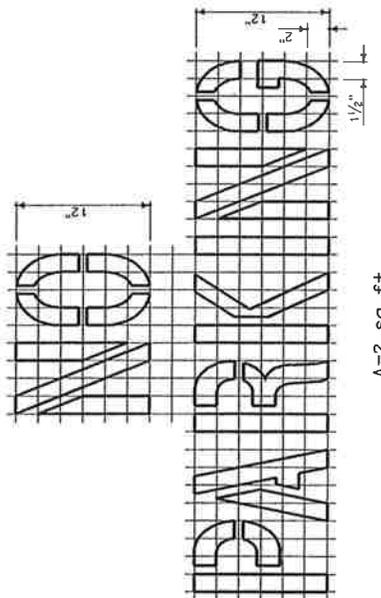
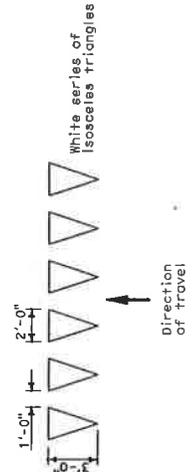

STATE OF CALIFORNIA
DEPARTMENT OF TRANSPORTATION

**PAVEMENT MARKINGS
WORDS AND CROSSWALKS**

NO SCALE

A24E

DIST	COUNTY	ROUTE	POST MILE	SHEET NO.	TOTAL SHEETS

REGISTERED CIVIL ENGINEER
 May 1, 2006
 PLANS EXPIRATION DATE
 I hereby certify that I am a duly Licensed Professional Engineer in the State of California and that I am the author of the above plans and that I am responsible for the accuracy and completeness of electronic copies of this plan.

To get the Caltrans web site, go to: <http://www.dir.ca.gov>

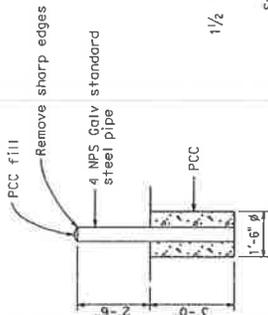

GUARD POST

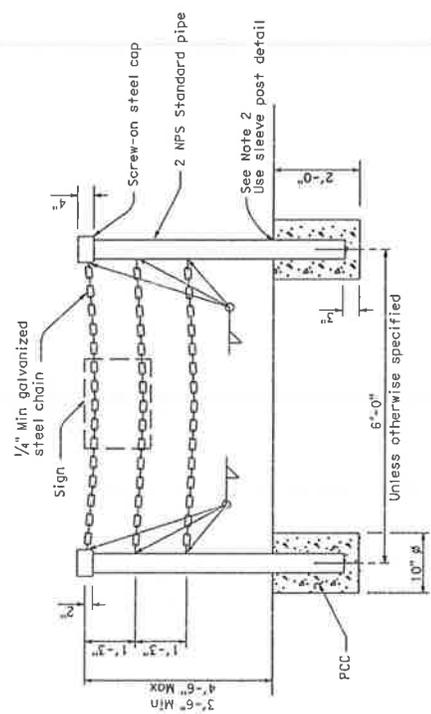

TYPE II

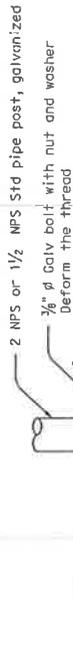

SLEEVE POST DETAIL
 Use unless otherwise specified or shown on plans

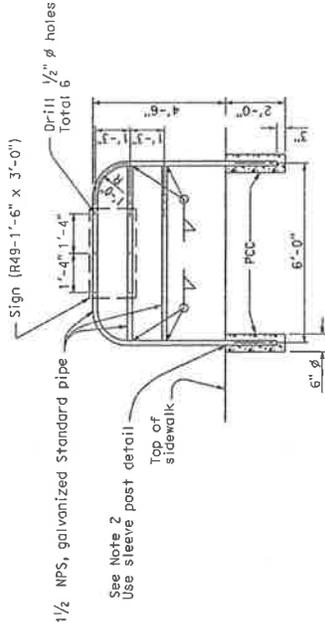
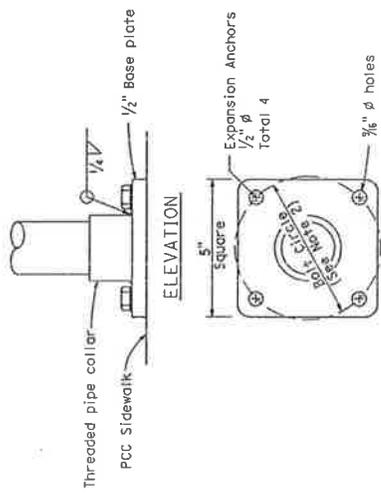

TYPE I

NOTES:

1. Pipe post to be set 1'-6" back from face of curb unless otherwise specified.
2. Where barricade posts are installed in existing concrete sidewalk, the post may be anchored to the sidewalk as shown in the "Post Anchorage Detail". Bolt circle diameter shall be 4" minimum for Type I barricade and 5" minimum for Type II barricade.
3. Steel sleeve to be constructed with a diameter 1/8" larger than post. Wall thickness of sleeve to be same as post or larger.
4. Contractor may submit alternative details for approval by the Engineer.
5. For minimum pipe diameters and wall thickness refer to ASTM A6M.

STATE OF CALIFORNIA
 DEPARTMENT OF TRANSPORTATION
**ELECTRICAL SYSTEMS
 (PEDESTRIAN BARRICADES)**
 NO SCALE
ES-7P