

FORM APPROVED COUNTY COUNSEL
 BY: MM Victor 4/19/13
 DATE: _____
 MARSHAL VICTOR

Departmental Concurrence

**SUBMITTAL TO THE BOARD OF SUPERVISORS
 COUNTY OF RIVERSIDE, STATE OF CALIFORNIA**

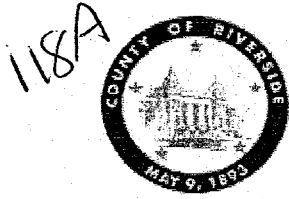

FROM: TLMA - Transportation Department

SUBMITTAL DATE:
 April 11, 2013

SUBJECT: Temescal Canyon Road and Dos Lagos Drive Improvements Project, El Cerrito area adjacent to the City of Corona.

RECOMMENDED MOTION: That the Board of Supervisors:

1. Approve four Addenda to the specifications and plans, issued prior to the February 27, 2013 bid opening.
2. Accept the low bid of Mamco, Inc. dba AlAbbasi of Riverside, CA in the amount of \$269,000.



 Juan C. Perez
 Director of Transportation and Land Management

JCP:rrj:rr
 (Continued On Attached Pages)

FINANCIAL DATA	Current F.Y. Total Cost:	\$ 269,000	In Current Year Budget:	Yes
	Current F.Y. Net County Cost:	\$ 0	Budget Adjustment:	No
	Annual Net County Cost:	\$ 0	For Fiscal Year:	2012/2013

SOURCE OF FUNDS: Gas Tax-Prop 111 (46%), Gas Tax (ABX8-9 Mar 2010 New HUTA) (54%)	Positions To Be Deleted Per A-30	<input type="checkbox"/>
	Requires 4/5 Vote	<input type="checkbox"/>

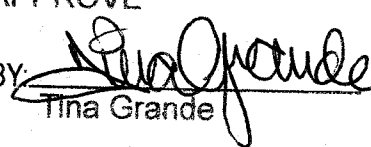
There are no General Funds used in this project.

C.E.O. RECOMMENDATION: APPROVE
 BY: 
 Tina Grande
 County Executive Office Signature

Dept Recomm.: Consent Policy
 Per Exec. Ofc.: Consent Policy

MINUTES OF THE BOARD OF SUPERVISORS

On motion of Supervisor Ashley, seconded by Supervisor Tavaglione and duly carried by unanimous vote, IT WAS ORDERED that the above matter is approved as recommended.

Ayes: Jeffries, Tavaglione, Stone, Benoit and Ashley
 Nays: None
 Absent: None
 Date: April 23, 2013
 xc: Transp.

Kecia Harper-Ihem
 Clerk of the Board
 By: 
 Deputy

Prev. Agn. Ref. 1/29/13, Item 3.44 | District: 1/1 | Agenda Number:

3-63

The Honorable Board of Supervisors

RE: Temescal Canyon Road and Dos Lagos Drive Improvements Project, El Cerrito area adjacent to the City of Corona.

April 11, 2013

Page 2 of 2

3. Award the contract to Mamco, Inc. dba AIAbbasi and authorize the Chairman of the Board to execute the contract documents.

BACKGROUND: By Minute Order dated January 29, 2013 (Agenda Item 3.44) the Board authorized the Clerk of the Board to advertise for the construction of Temescal Canyon Road and Dos Lagos Drive improvements, in the El Cerrito area adjacent to the City of Corona.

During the advertisement period, four addenda were issued to all registered plan holders as a supplement to the specifications and special provisions. Bidders are required to acknowledge and take into account all issued addenda on their Contractor's Proposal. The addenda were issued to clarify and modify the approved contract documents. The addenda are attached and designated as Addendum No. 1, Addendum No. 2, Addendum No. 3, and Addendum No. 4.

Bids for the project were opened in the office of the Director of Transportation and Land Management at 2:00 PM, Wednesday, February 27, 2013. Eleven bids were received, ranging from \$269,000 to \$358,995. The basis for the selection of a contractor is the lowest responsive and responsible bid. The lowest responsible bid was submitted by Mamco, Inc. dba AIAbbasi of Riverside, CA in the amount of \$269,000, which is \$3,450 (1.3%) above the Engineer's Estimate. The project is expected to finish within the existing budget as shown on Attachment 'A'.

The project will widen the western half-width of Temescal Canyon Road south of Dos Lagos Drive for 650 feet. This project also includes construction of curb, gutter, standard and meandering sidewalk, commercial driveways, drainage improvements, installing chain link fence, signing, striping and associated work.

The contractor is qualified to perform the work as outlined in the bid and has executed the contract and provided bonds and insurance documents, which meet the requirements of the contract.

Project Number: C2-0154

Form 11 Attachment

Contract/Lease/Purchase Summary Data

Contract (for Services)

- Approval/Renewal
- Sole Source
- Personal Services
- Independent Contractor
- Other than Low Bid
- Change Order
- Public Works

Lease

- Approval/Renewal
- Multi-Year Lease
- Equipment
- Real Property
- Change Order

Purchase (for Materials)

- Sole Source
- Other than Low Bid
- Change Order

Selection Committee Member Names (RFP=s Only)

User Department:	Transportation Department
-------------------------	---------------------------

N/A

Vendor/Lessor Name:	Mamco, Inc. dba AlAbbasi
----------------------------	--------------------------

Minority Status:

M W DV None

Vendor/Lessor Location:	Riverside, CA
--------------------------------	---------------

Local Preference Applied: Yes No N/A

Local Preference Award Cost \$
(5% maximum preference)

Local Preference FYTD: Cost \$

of Orders

Applicable Board Policy #

Comments:

RFQ/RFP Process:

Date Mailed:
Response Date:
of Responses:
of Qualified Responses:

Bidding Process (OPTION 1 Selected for Award):

Bid Range: \$ 269,000.00 to \$358,995.00
Local Bid Range: N/A
Responsive and
Responsible Bid Range: \$ 269,000.00 to \$358,995.00

Note: Selection of low bid based on the sum of all bid schedules, whether or not all bid schedules are awarded.

Contract/Lease Renewals Only

Existing Agreement Items

Proposed Agreement Items

1. Rates
2. Terms
3. Conditions
4. Legal Issues
5. Accountability
6. Utilities

(continue on blank sheet if necessary)

NOTE: COMPETITIVELY BID PUBLIC WORKS CONTRACT

AGREEMENT

THIS AGREEMENT is entered into at Riverside, California as of the date set forth below is between County of Riverside hereafter called "County" and Mamco, Inc. dba AIAbbasi hereafter called "Contractor".

W I T N E S S E T H

RECITALS:

1. Contractor has submitted to County his Contractor's Proposal for the construction of County Project, **Temescal Canyon Road and Dos Lagos Drive, Street Improvements Project, El Cerrito Area Adjacent to the City of Corona, Project No. C2-0154**, in strict accordance with the Contract Documents identified below and County has accepted said Proposal.
2. Contractor states that he has reexamined his Contractor's Proposal and found it to be correct, has ascertained that his subcontractors are properly licensed and possess the requisite skill and forces, has reexamined the site and Contract Documents and is of the opinion that he can presently do the work in accordance with the Contract Documents for the money set forth in his Proposal to be paid as provided in the Contract Documents.

AGREEMENT:

IT IS AGREED BY THE PARTIES AS FOLLOWS:

1. Contract Documents. The entire contract consists of the following: (a) The Agreement. (b) The Notice Inviting Bids. (c) The Instruction to Bidders. (d) The Contractor's Proposal. (e) The Bid Bond. (f) The Payment Bond. (g) The Performance Bond. (h) The General Conditions. (i) The Special Provisions. (j) The Standard Specifications of the State of California Department of Transportation edition of May 2006 as modified in other portions of the Contract Documents. (k) The Standard Plans of the Department of Transportation identified on the plans or in the Special Provisions. (l) The Plans. (m) Addenda No. **one, two, three, and four**. (n) The Determination of Prevailing Wage Rates for Public Work. (o) Any Change Orders issued. (p) Any additional or supplemental specifications, notice, instructions and drawings issued in accordance with the provisions of the Contract Documents. All of said Documents presently in existence are by this reference incorporated herein with like effect as if here set forth in full and upon the proper issuance of other documents they shall likewise be deemed incorporated. The Bid Bond is exonerated upon execution of this Agreement and the Payment Bond and Faithful Performance Bond.
2. The Work. Contractor shall do all things necessary to construct the work generally described in Recital No. 1 in accordance with the Contract Documents.

3. Liquidated Damages and Time of Completion. Attention is directed to the provisions in Section 8-1.06, "Time of Completion", and in Section 8-1.07, "Liquidated Damages", of the Standard Specifications and these Special Provisions.

The Contractor shall begin work within 15 days of the date stated within the written "Notice to Proceed".

The Contractor shall notify the Engineer, in writing, of his intent to begin work at least 72 hours before work is begun. The notice shall be delivered to the Transportation Department's Construction Engineer and shall specify the date the Contractor intends to start. If the project has more than one location of work, a separate notice shall be given for each location.

Should the Contractor begin work in advance of receiving a written "Notice to Proceed", any work performed by him in advance of the date stated in the "Notice to Proceed" shall be considered as having been done by him at his own risk and as a volunteer and subject to the following:

- (1) The Contractor shall, on commencing operations, take all precautions required for public safety and shall observe all the provisions in the Specifications and the Special Provisions.
 - (2) All work done according to the contract prior to the issuance of the "Notice to Proceed", will be considered authorized work and will be paid for as provided in the contract.
 - (3) The Contractor shall not be entitled to any additional compensation or an extension of time for any delay, hindrance or interference caused by or attributable to commencement of work prior to the issuance of the "Notice to Proceed".
4. Compensation. Contractor shall be paid in the manner set forth in the Contract Documents the amount of his Proposal as accepted by County, the above rates, subject to additions and deductions as provided in the Contract Documents. Said Proposal is on file in the Office of the Clerk of the Board of Supervisors of County.

**Temescal Canyon Road and Dos Lagos Drive
Street Improvements Project
El Cerrito Area Adjacent to the City of Corona**

Project No. C2-0154

AGREEMENT

ITEM No.	ITEM CODE	ITEM	UNIT	ESTIMATED QUANTITY	ITEM PRICE (IN FIGURES)	TOTAL (IN FIGURES)
BASE BID:						
1	066102	DUST ABATEMENT	LS	1	5,949.75	5,949.75
2	074020	WATER POLLUTION CONTROL	LS	1	4,300.00	4,300.00
3	120100	TRAFFIC CONTROL SYSTEM	LS	1	18,100.00	18,100.00
4	160101	CLEARING AND GRUBBING	LS	1	18,500.00	18,500.00
5	170101	DEVELOP WATER SUPPLY	LS	1	540.00	540.00
6	190101	ROADWAY EXCAVATION	CY	655	16.00	10,480.00
7	731521	MINOR CONCRETE (SIDEWALK) (INCLUDING 12" HIGH AND 6" WIDE CONCRETE CURB BEHIND SIDEWALK)	SQFT	5,000	3.90	19,500.00
8	017305	MINOR CONCRETE (CURB AND GUTTER) (CRS 201)	LF	500	16.50	8,250.00
9	017312	MINOR CONCRETE (COMERCIAL DRIVEWAY) (CRS 207A)	EA	4	5,900.00	23,600.00
10	260201	CLASS 2 AGGREGATE BASE	CY	450	34.00	15,300.00
11	390130	HOT MIX ASPHALT	TON	750	78.00	58,500.00
12	650014	18" REINFORCED CONCRETE PIPE	LF	86	80.00	6,880.00
13	650018	24" REINFORCED CONCRETE PIPE	LF	20	110.00	2,200.00
14	153103	COLD PLANE ASPHALT CONCRETE PAVEMENT	SQYD	2,355	3.00	7,065.00
15	800320	CHAIN LINK FENCE (TYPE CL-4)	LF	175	14.00	2,450.00
16	800360	CHAIN LINK FENCE (TYPE CL-6) (INCLUDING GATE)	LF	340	24.00	8,160.00

AGREEMENT (Continued)

ITEM No.	ITEM CODE	ITEM	UNIT	ESTIMATED QUANTITY	ITEM PRICE (IN FIGURES)	TOTAL (IN FIGURES)
BASE BID:						
17	017110	MANHOLE (RCFC & WCDS MH 254)	EA	1	4,375.00	4,375.00
18	017003	CATCH BASIN (CURB INLET) (CRS 300)	EA	2	4,727.00	9,454.00
19	840515	THERMOPLASTIC PAVEMENT MARKING	SQFT	285	5.25	1,496.25
20	566011	ROADSIDE SIGN - ONE POST	EA	2	262.00	524.00
21	840656	PAINT TRAFFIC STRIPE (2-COAT)	LF	3,800	0.52	1,976.00
22	019901	DEMOBILIZATION	LS	1	10,000.00	10,000.00
23	394002	PLACE ASPHALT CONCRETE (MISCELLANEOUS AREA)	SQYD	200	32.00	6,400.00
24	010602	MISCELLANEOUS WORK (AS DIRECTED)	FA	1	25,000.00	25,000.00

PROJECT TOTAL: _____ Two hundred sixty nine thousand dollars and zero cents **\$269,000.00**

ITEMS 1-24 "WORDS"

Temescal Canyon Road and Dos Lagos Drive
Street Improvements Project
El Cerrito Area Adjacent to the City of Corona

Project No. C2-0154

IN WITNESS WHEREOF the parties hereto have executed this agreement as of the date set forth below.

COUNTY OF RIVERSIDE

Mamco, Inc. dba AlAbbasi

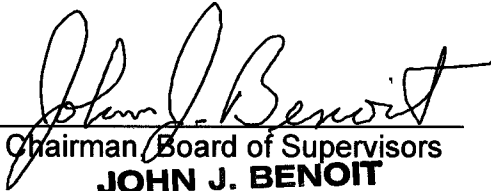
BY 
Chairman, Board of Supervisors
JOHN J. BENOIT

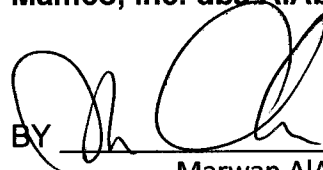
BY 
Marwan AlAbbasi

Dated APR 23 2013

TITLE: Secretary
(If Corporation, Affix Seal)

ATTEST:
Kecia Harper-Ihem, Clerk of the Board

ATTEST: 
Rumzi AlAbbasi

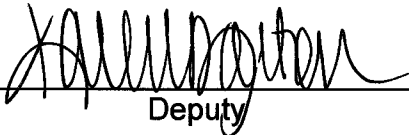
BY 
Deputy

TITLE: Vice President

Licensed in accordance with an act providing for the registration of Contractors,

License No. 883649

Federal Employer Identification Number:

72-1535984

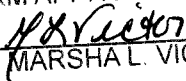
FORM APPROVED COUNTY COUNSEL
BY:  4/9/13 DATE
MARSHA L. VICTOR

BY _____
"County"
(Seal)

"Corporation"
(Seal)

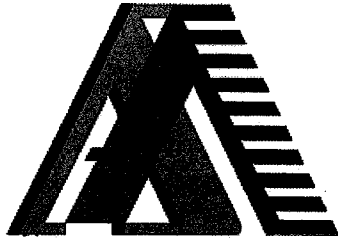

alabbasi

CONSTRUCTION AND ENGINEERING
Lic. No. 883649

Mamco, Inc. dba Alabbasi Corporate Resolution to Execute Contracts

At a meeting of the corporation today, after considerable discussion, the following resolution was moved, seconded, and unanimously adopted;

Resolved that any of the following persons, Marwan Alabbasi, Elizabeth Alabbasi, or Rumzi M. Alabbasi be; and they hereby are, authorized without further authorization of the board of directors to enter into and execute on behalf of the corporation any and all contracts to do corporate business for Mamco, Inc.

In witness whereof, I have hereunto set my hand as such secretary and affixed the corporate seal of said corporation this 1st day of October, 2012.

AUTHORIZED SIGNATURES

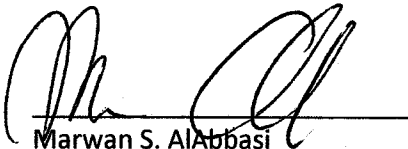

Marwan S. Alabbasi

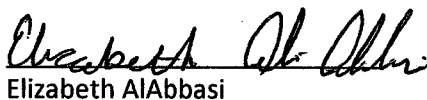

Elizabeth Alabbasi

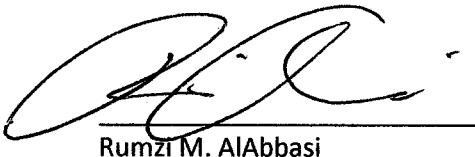

Rumzi M. Alabbasi

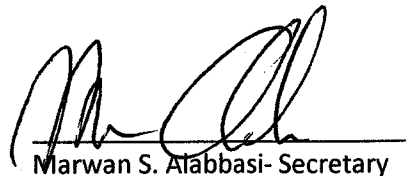

Marwan S. Alabbasi- Secretary

PERFORMANCE BOND

Recitals:

1. **Mamco, Inc. dba AlAbbasi** (Contractor) intend to enter into an Agreement with COUNTY OF RIVERSIDE (County) for construction of public work known as **Temescal Canyon Road and Dos Lagos Drive, Street Improvements Project , El Cerrito Area Adjacent to the City of Corona, Project No. C2-0154.**

2. _____, a _____ corporation (Surety), is the Surety under this Bond.

Agreement:

We; Contractor, as Principal, and Surety, as Surety, jointly and severally agree, state, and are bound unto County, as obligee, as follows:

1. The amount of the obligation of this Bond is 100% of the estimated contract price for the Project of **\$ 269,000.00 (Two hundred sixty nine thousand dollars and zero cents)**, and inures to the benefit of County.

2. This Bond is exonerated by Contractor doing all things to be kept and performed by it in strict conformance with the Contract Documents for the Project, otherwise it remains in full force and effect for the recovery of loss, damage and expense of County resulting from failure of Contractor to so act. All of said Contract Documents are incorporated herein.

3. This obligation is binding on our successors and assigns.

4. For value received, Surety stipulates and agrees that no change, time extension, prepayment to Contractor, alteration or addition to the terms and requirements of the Contract Documents or the work to be performed thereunder shall affect its obligations hereunder and waives notice as to such matters, except the total contract price cannot be increased by more than 10% without approval of Surety.

THIS BOND is executed as of _____.

By _____

By _____

By _____

Type Name _____

Its Attorney in Fact
"Surety"

Title _____

"Contractor"

(Corporate Seal)

(Corporate Seal)

NOTE: This Bond must be executed by both parties with corporate seal affixed. All signatures must be acknowledged. (Attach acknowledgements).

Payment Bond

(Public Work - Civil Code 9550 et seq.)

The makers of this Bond are Mamco, Inc. dba AlAbbasi, as Principal and Original Contractor and _____, a corporation, authorized to issue Surety Bonds in California, as Surety, and this Bond is issued in conjunction with that certain public works contract to be executed between Principal and COUNTY OF RIVERSIDE a public entity, as Owner, for \$ 269,000.00 (Two hundred sixty nine thousand dollars and zero cents), the total amount payable. The amount of this bond is one hundred percent (100%) of said sum. Said contract is for public work generally consisting of Temescal Canyon Road and Dos Lagos Drive, Street Improvements Project, El Cerrito Area Adjacent to the City of Corona, Project No. C2-0154.

The beneficiaries of this Bond are as is stated in 9554 of the Civil Code and requirements and conditions of this Bond are as is set forth in 9554, 9558, 9564 and 9560 of said code. Without notice, Surety consents to extension of time for performance, change in requirements, amount of compensation, or prepayment under said contract.

Dated: _____

Original Contractor – Principal

Surety

By _____

By _____

Title _____

Its Attorney In Fact

(If corporation, affix seal)

(Corporate Seal)

(Corporate Seal)

STATE OF _____ }
COUNTY OF _____ }

ss. SURETY'S ACKNOWLEDGEMENT

On _____ before me, _____ personally appeared, _____, known to me, or proved to me on the basis of satisfactory evidence, to be the person whose name is subscribed to the within instrument and acknowledged to me that he executed the same in his authorized capacities, and that by his signature on the instrument the person, or the entity upon behalf of which the person acted, executed the instrument.

WITNESS my hand and official seal.

Signature of Notary Public

Notary Public (Seal)

NOTE: This Bond must be executed by both parties with corporate seal affixed. All signatures must be acknowledged. (Attach acknowledgements).

EXECUTED IN DUPLICATE

Bond No. 01993900130
Premium \$5,035.00
Premium is for Contract Term and Subject
to Adjustment Based on Final Contract Price

PERFORMANCE BOND

Recitals:



1. **Mamco, Inc. dba AlAbbasi** (Contractor) intend to enter into an Agreement with COUNTY OF RIVERSIDE (County) for construction of public work known as **Temescal Canyon Road and Dos Lagos Drive, Street Improvements Project, El Cerrito Area Adjacent to the City of Corona, Project No. C2-0154.**
2. Philadelphia Indemnity Insurance Company, a Pennsylvania corporation (Surety), is the Surety under this Bond.

Agreement:

We, Contractor, as Principal, and Surety, as Surety, jointly and severally agree, state, and are bound unto County, as obligee, as follows:

1. The amount of the obligation of this Bond is 100% of the estimated contract price for the Project of **\$ 269,000.00 (Two hundred sixty nine thousand dollars and zero cents)**, and inures to the benefit of County.
2. This Bond is exonerated by Contractor doing all things to be kept and performed by it in strict conformance with the Contract Documents for the Project, otherwise it remains in full force and effect for the recovery of loss, damage and expense of County resulting from failure of Contractor to so act. All of said Contract Documents are incorporated herein.
3. This obligation is binding on our successors and assigns.
4. For value received, Surety stipulates and agrees that no change, time extension, prepayment to Contractor, alteration or addition to the terms and requirements of the Contract Documents or the work to be performed thereunder shall affect its obligations hereunder and waives notice as to such matters, except the total contract price cannot be increased by more than 10% without approval of Surety.

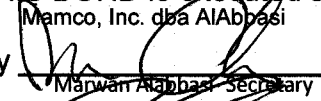
THIS BOND is executed as of March 14, 2013

Mamco, Inc. dba AlAbbasi
By 
Marwan Alabbasi- Secretary
By 
Rumzi Alabbasi- Vice President

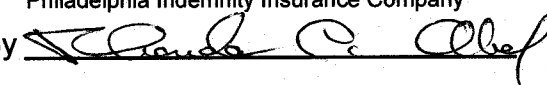
Philadelphia Indemnity Insurance Company
By 
Type Name Rhonda C. Abel
Its Attorney in Fact
"Surety"

Title Secretary/ Vice President
"Contractor"

(Corporate Seal)

(Corporate Seal)

NOTE: This Bond must be executed by both parties with corporate seal affixed. All signatures must be acknowledged. (Attach acknowledgements).

CALIFORNIA ALL-PURPOSE CERTIFICATE OF ACKNOWLEDGMENT

State of California

County of Riverside

On 3/21/13 before me, Rami M. Alabbasi, Notary Public
(Here insert name and title of the officer)

personally appeared Rumzi Alabbasi

who proved to me on the basis of satisfactory evidence to be the person(s) whose name(s) is are subscribed to the within instrument and acknowledged to me that he/she/they executed the same in his/her/their authorized capacity(ies), and that by his/her/their signature(s) on the instrument the person(s), or the entity upon behalf of which the person(s) acted, executed the instrument.

I certify under PENALTY OF PERJURY under the laws of the State of California that the foregoing paragraph is true and correct.

WITNESS my hand and official seal.

[Signature]
 Signature of Notary Public

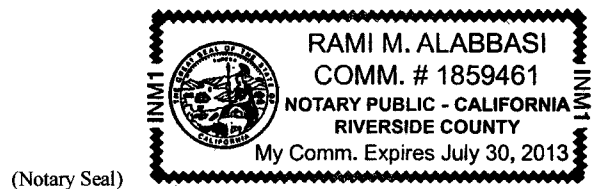

ADDITIONAL OPTIONAL INFORMATION

INSTRUCTIONS FOR COMPLETING THIS FORM

Any acknowledgment completed in California must contain verbiage exactly as appears above in the notary section or a separate acknowledgment form must be properly completed and attached to that document. The only exception is if a document is to be recorded outside of California. In such instances, any alternative acknowledgment verbiage as may be printed on such a document so long as the verbiage does not require the notary to do something that is illegal for a notary in California (i.e. certifying the authorized capacity of the signer). Please check the document carefully for proper notarial wording and attach this form if required.

- State and County information must be the State and County where the document signer(s) personally appeared before the notary public for acknowledgment.
- Date of notarization must be the date that the signer(s) personally appeared which must also be the same date the acknowledgment is completed.
- The notary public must print his or her name as it appears within his or her commission followed by a comma and then your title (notary public).
- Print the name(s) of document signer(s) who personally appear at the time of notarization.
- Indicate the correct singular or plural forms by crossing off incorrect forms (i.e. ~~he/she/they~~, is /are) or circling the correct forms. Failure to correctly indicate this information may lead to rejection of document recording.
- The notary seal impression must be clear and photographically reproducible. Impression must not cover text or lines. If seal impression smudges, re-seal if a sufficient area permits, otherwise complete a different acknowledgment form.
- Signature of the notary public must match the signature on file with the office of the county clerk.
 - ❖ Additional information is not required but could help to ensure this acknowledgment is not misused or attached to a different document.
 - ❖ Indicate title or type of attached document, number of pages and date.
 - ❖ Indicate the capacity claimed by the signer. If the claimed capacity is a corporate officer, indicate the title (i.e. CEO, CFO, Secretary).
- Securely attach this document to the signed document

DESCRIPTION OF THE ATTACHED DOCUMENT

(Title or description of attached document)

(Title or description of attached document continued)

Number of Pages _____ Document Date _____

(Additional information)

CAPACITY CLAIMED BY THE SIGNER

Individual (s)

Corporate Officer

(Title)

Partner(s)

Attorney-in-Fact

Trustee(s)

Other _____

CALIFORNIA ALL-PURPOSE CERTIFICATE OF ACKNOWLEDGMENT

State of California

County of Riverside

On 3/21/13 before me, Rami M. Alabbasi, Notary Public,
(Here insert name and title of the officer)

personally appeared Marwan Alabbasi

who proved to me on the basis of satisfactory evidence to be the person(s) whose name(s) is are subscribed to the within instrument and acknowledged to me that he she/they executed the same in his her/their authorized capacity(ies), and that by his her/their signature(s) on the instrument the person(s), or the entity upon behalf of which the person(s) acted, executed the instrument.

I certify under PENALTY OF PERJURY under the laws of the State of California that the foregoing paragraph is true and correct.

WITNESS my hand and official seal.

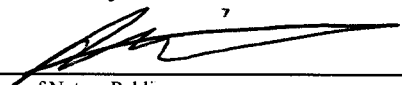

Signature of Notary Public

(Notary Seal)

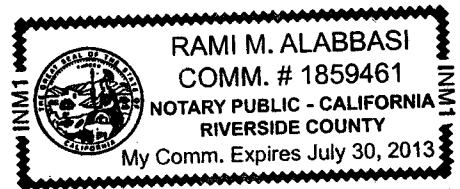

ADDITIONAL OPTIONAL INFORMATION

DESCRIPTION OF THE ATTACHED DOCUMENT

(Title or description of attached document)

(Title or description of attached document continued)

Number of Pages _____ Document Date _____

(Additional information)

CAPACITY CLAIMED BY THE SIGNER

- Individual (s)
 Corporate Officer

(Title)

- Partner(s)
 Attorney-in-Fact
 Trustee(s)
 Other _____

INSTRUCTIONS FOR COMPLETING THIS FORM

Any acknowledgment completed in California must contain verbiage exactly as appears above in the notary section or a separate acknowledgment form must be properly completed and attached to that document. The only exception is if a document is to be recorded outside of California. In such instances, any alternative acknowledgment verbiage as may be printed on such a document so long as the verbiage does not require the notary to do something that is illegal for a notary in California (i.e. certifying the authorized capacity of the signer). Please check the document carefully for proper notarial wording and attach this form if required.

- State and County information must be the State and County where the document signer(s) personally appeared before the notary public for acknowledgment.
- Date of notarization must be the date that the signer(s) personally appeared which must also be the same date the acknowledgment is completed.
- The notary public must print his or her name as it appears within his or her commission followed by a comma and then your title (notary public).
- Print the name(s) of document signer(s) who personally appear at the time of notarization.
- Indicate the correct singular or plural forms by crossing off incorrect forms (i.e. ~~he~~/she/~~they~~, is /are) or circling the correct forms. Failure to correctly indicate this information may lead to rejection of document recording.
- The notary seal impression must be clear and photographically reproducible. Impression must not cover text or lines. If seal impression smudges, re-seal if a sufficient area permits, otherwise complete a different acknowledgment form.
- Signature of the notary public must match the signature on file with the office of the county clerk.
 - ❖ Additional information is not required but could help to ensure this acknowledgment is not misused or attached to a different document.
 - ❖ Indicate title or type of attached document, number of pages and date.
 - ❖ Indicate the capacity claimed by the signer. If the claimed capacity is a corporate officer, indicate the title (i.e. CEO, CFO, Secretary).
- Securely attach this document to the signed document

CALIFORNIA ALL-PURPOSE ACKNOWLEDGMENT

State of California

County of Orange

On MAR 14 2013 before me, Jeri Apodaca, Notary Public
Date Here Insert Name and Title of the Officer

personally appeared Rhonda C. Abel
Name(s) of Signer(s)

who proved to me on the basis of satisfactory evidence to be the person(s) whose name(s) is/are subscribed to the within instrument and acknowledged to me that ~~he/she/they~~ executed the same in ~~his/her/their~~ authorized capacity(ies), and that by ~~his/her/their~~ signature(s) on the instrument the person(s), or the entity upon behalf of which the person(s) acted, executed the instrument.

I certify under PENALTY OF PERJURY under the laws of the State of California that the foregoing paragraph is true and correct.

WITNESS my hand and official seal.

Signature [Handwritten Signature]
Signature of Notary Public

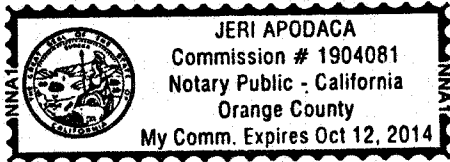

Place Notary Seal Above

OPTIONAL

Though the information below is not required by law, it may prove valuable to persons relying on the document and could prevent fraudulent removal and reattachment of this form to another document.

Description of Attached Document

Title or Type of Document: _____

Document Date: _____ Number of Pages: _____

Signer(s) Other Than Named Above: _____

Capacity(ies) Claimed by Signer(s)

Signer's Name: _____

- Individual
- Corporate Officer — Title(s): _____
- Partner — Limited General
- Attorney in Fact
- Trustee
- Guardian or Conservator
- Other: _____

Signer Is Representing: _____

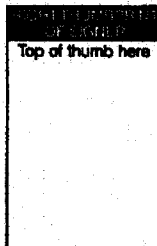

Signer's Name: _____

- Individual
- Corporate Officer — Title(s): _____
- Partner — Limited General
- Attorney in Fact
- Trustee
- Guardian or Conservator
- Other: _____

Signer Is Representing: _____

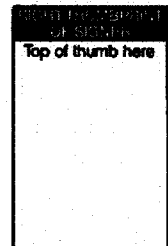

EXECUTED IN DUPLICATE

Payment Bond

(Public Work - Civil Code 9550 et seq.)

The makers of this Bond are **Mamco, Inc. dba AlAbbasi**, as Principal and Original Contractor and Philadelphia Indemnity Insurance Company, a corporation, authorized to issue Surety Bonds in California, as Surety, and this Bond is issued in conjunction with that certain public works contract to be executed between Principal and COUNTY OF RIVERSIDE a public entity, as Owner, for **\$ 269,000.00 (Two hundred sixty nine thousand dollars and zero cents)**, the total amount payable. The amount of this bond is one hundred percent (100%) of said sum. Said contract is for public work generally consisting of **Temescal Canyon Road and Dos Lagos Drive, Street Improvements Project, El Cerrito Area Adjacent to the City of Corona, Project No. C2-0154.**

The beneficiaries of this Bond are as is stated in 9554 of the Civil Code and requirements and conditions of this Bond are as is set forth in 9554, 9558, 9564 and 9560 of said code. Without notice, Surety consents to extension of time for performance, change in requirements, amount of compensation, or prepayment under said contract.

Dated: March 14, 2013

Mamco, Inc. dba AlAbbasi
Original Contractor - Principal

Philadelphia Indemnity Insurance Company
Surety

By 
Marwan AlAbbasi

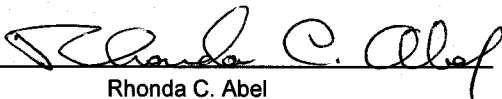
By 
Rhonda C. Abel
Its Attorney In Fact

Title Secretary

(If corporation, affix seal)

(Corporate Seal)

(Corporate Seal)

STATE OF _____
COUNTY OF _____

} ss. SURETY'S ACKNOWLEDGEMENT

SEE ATTACHED NOTARY ACKNOWLEDGMENT

On _____ before me, _____ personally appeared, _____, known to me, or proved to me on the basis of satisfactory evidence, to be the person whose name is subscribed to the within instrument and acknowledged to me that he executed the same in his authorized capacities, and that by his signature on the instrument the person, or the entity upon behalf of which the person acted, executed the instrument.

WITNESS my hand and official seal.

Signature of Notary Public

Notary Public (Seal)

**NOTE: This Bond must be executed by both parties with corporate seal affixed.
All signatures must be acknowledged. (Attach acknowledgements).**

CALIFORNIA ALL-PURPOSE CERTIFICATE OF ACKNOWLEDGMENT

State of California

County of Riverside

On 3/21/13 before me, Rami M. Alabbasi, Notary Public,
(Here insert name and title of the officer)

personally appeared Marwan Alabbasi,

who proved to me on the basis of satisfactory evidence to be the person(s) whose name(s) is/are subscribed to the within instrument and acknowledged to me that he/she/they executed the same in his/her/their authorized capacity(ies), and that by his/her/their signature(s) on the instrument the person(s), or the entity upon behalf of which the person(s) acted, executed the instrument.

I certify under PENALTY OF PERJURY under the laws of the State of California that the foregoing paragraph is true and correct.

WITNESS my hand and official seal.

[Signature]
Signature of Notary Public

(Notary Seal)

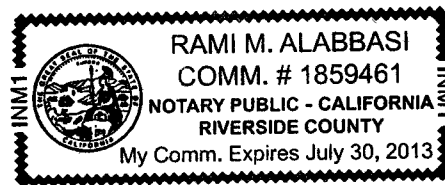

ADDITIONAL OPTIONAL INFORMATION

DESCRIPTION OF THE ATTACHED DOCUMENT

(Title or description of attached document)

(Title or description of attached document continued)

Number of Pages _____ Document Date _____

(Additional information)

CAPACITY CLAIMED BY THE SIGNER

- Individual (s)
 Corporate Officer

(Title)

- Partner(s)
 Attorney-in-Fact
 Trustee(s)
 Other _____

INSTRUCTIONS FOR COMPLETING THIS FORM

Any acknowledgment completed in California must contain verbiage exactly as appears above in the notary section or a separate acknowledgment form must be properly completed and attached to that document. The only exception is if a document is to be recorded outside of California. In such instances, any alternative acknowledgment verbiage as may be printed on such a document so long as the verbiage does not require the notary to do something that is illegal for a notary in California (i.e. certifying the authorized capacity of the signer). Please check the document carefully for proper notarial wording and attach this form if required.

- State and County information must be the State and County where the document signer(s) personally appeared before the notary public for acknowledgment.
- Date of notarization must be the date that the signer(s) personally appeared which must also be the same date the acknowledgment is completed.
- The notary public must print his or her name as it appears within his or her commission followed by a comma and then your title (notary public).
- Print the name(s) of document signer(s) who personally appear at the time of notarization.
- Indicate the correct singular or plural forms by crossing off incorrect forms (i.e. ~~he/she/they~~, is /are) or circling the correct forms. Failure to correctly indicate this information may lead to rejection of document recording.
- The notary seal impression must be clear and photographically reproducible. Impression must not cover text or lines. If seal impression smudges, re-seal if a sufficient area permits, otherwise complete a different acknowledgment form.
- Signature of the notary public must match the signature on file with the office of the county clerk.
 - ❖ Additional information is not required but could help to ensure this acknowledgment is not misused or attached to a different document.
 - ❖ Indicate title or type of attached document, number of pages and date.
 - ❖ Indicate the capacity claimed by the signer. If the claimed capacity is a corporate officer, indicate the title (i.e. CEO, CFO, Secretary).
- Securely attach this document to the signed document

CALIFORNIA ALL-PURPOSE ACKNOWLEDGMENT

State of California }
 County of Orange }

On MAR 14 2013 before me, Jeri Apodaca, Notary Public
Date Here Insert Name and Title of the Officer

personally appeared Rhonda C. Abel
Name(s) of Signer(s)

who proved to me on the basis of satisfactory evidence to be the person(s) whose name(s) is/~~are~~ subscribed to the within instrument and acknowledged to me that ~~he~~/~~she~~/~~it~~ executed the same in ~~his~~/~~her~~/~~their~~ authorized capacity(~~ies~~), and that by ~~his~~/~~her~~/~~their~~ signature(s) on the instrument the person(s), or the entity upon behalf of which the person(s) acted, executed the instrument.

I certify under PENALTY OF PERJURY under the laws of the State of California that the foregoing paragraph is true and correct.

WITNESS my hand and official seal.

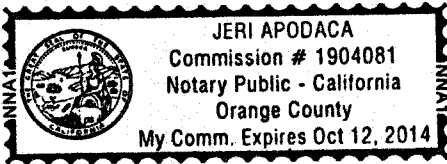

Signature Jeri Apodaca
Signature of Notary Public

Place Notary Seal Above

OPTIONAL

Though the information below is not required by law, it may prove valuable to persons relying on the document and could prevent fraudulent removal and reattachment of this form to another document.

Description of Attached Document

Title or Type of Document: _____

Document Date: _____ Number of Pages: _____

Signer(s) Other Than Named Above: _____

Capacity(ies) Claimed by Signer(s)

Signer's Name: _____

- Individual
- Corporate Officer — Title(s): _____
- Partner — Limited General
- Attorney in Fact
- Trustee
- Guardian or Conservator
- Other: _____



Signer Is Representing: _____

Signer's Name: _____

- Individual
- Corporate Officer — Title(s): _____
- Partner — Limited General
- Attorney in Fact
- Trustee
- Guardian or Conservator
- Other: _____

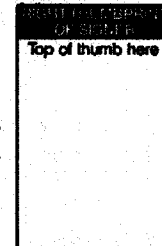

Signer Is Representing: _____

231 St. Asaph's Rd., Suite 100
Bala Cynwyd, PA 19004-0950

Power of Attorney

KNOW ALL PERSONS BY THESE PRESENTS: that **PHILADELPHIA INDEMNITY INSURANCE COMPANY** (the Company), a corporation organized and existing under the laws of the Commonwealth of Pennsylvania, does hereby constitute and appoint: [RACHELLE C. RHEULT, JERI APODACA, KIM LUU AND RHONDA C. ABEL OF ALLIANT INSURANCE SERVICES, INC.] its true and lawful Attorney(s) in fact with full authority to execute on its behalf bonds, undertakings, recognizances and other contracts of indemnity and writings obligatory in the nature thereof, issued in the course of its business and to bind the Company thereby, in an amount not to exceed \$5,000,000.00.]

This Power of Attorney is granted and is signed and sealed by facsimile under and by the authority of the following Resolution adopted by the Board of Directors of PHILADELPHIA INDEMNITY INSURANCE COMPANY at a meeting duly called the 1st day of July, 2011.

RESOLVED: That the Board of Directors hereby authorizes the President or any Vice President of the Company to: (1) Appoint Attorney(s) in Fact and authorize the Attorney(s) in Fact to execute on behalf of the Company bonds and undertakings, contracts of indemnity and other writings obligatory in the nature thereof and to attach the seal of the Company thereto; and (2) to remove, at any time, any such Attorney-in-Fact and revoke the authority given. And, be it

FURTHER RESOLVED: That the signatures of such officers and the seal of the Company may be affixed to any such Power of Attorney or certificate relating thereto by facsimile, and any such Power of Attorney so executed and certified by facsimile signatures and facsimile seal shall be valid and binding upon the Company in the future with the respect to any bond or undertaking to which it is attached.

IN TESTIMONY WHEREOF, PHILADELPHIA INDEMNITY INSURANCE COMPANY HAS CAUSED THIS INSTRUMENT TO BE SIGNED AND ITS CORPORATE SEAL TO BE AFFIXED BY ITS AUTHORIZED OFFICE THIS 15TH DAY OF NOVEMBER 2012.

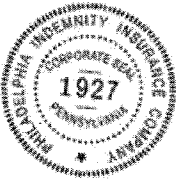

(Seal)

President

Sean S. Sweeney, President
Philadelphia Indemnity Insurance Company

On this 15th day of November 2012, before me came the individual who executed the preceding instrument, to me personally known, and being by me duly sworn said that he is the therein described and authorized officer of the **PHILADELPHIA INDEMNITY INSURANCE COMPANY**; that the seal affixed to said instrument is the Corporate seal of said Company; that the said Corporate Seal and his signature were duly affixed.

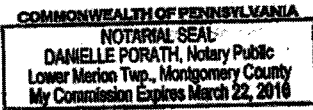

Notary Public:

residing at:

Bala Cynwyd, PA

(Notary Seal)

My commission expires:

March 22, 2016

I, Craig P. Keller, Executive Vice President, Chief Financial Officer and Secretary of PHILADELPHIA INDEMNITY INSURANCE COMPANY, do hereby certify that the foregoing resolution of the Board of Directors and this Power of Attorney issued pursuant thereto are true and correct and are still in full force and effect. I do further certify that Sean S. Sweeney, who executed the Power of Attorney as President, was on the date of execution of the attached Power of Attorney the duly elected President of PHILADELPHIA INDEMNITY INSURANCE COMPANY,

MAR 14 2013

In Testimony Whereof I have subscribed my name and affixed the facsimile seal of each Company this _____ day of _____ 20____.

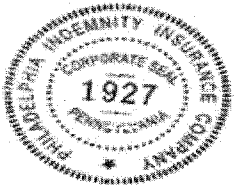

Craig P. Keller, Executive Vice President, Chief Financial Officer & Secretary
PHILADELPHIA INDEMNITY INSURANCE COMPANY

Company Profile

PHILADELPHIA INDEMNITY INSURANCE COMPANY
ONE BALA PLAZA SUITE 100
BALA CYNWYD, PA 19004
800-564-7766

Agent for Service of Process

NANCY FLORES, C/O CT CORPORATION SYSTEM 818 WEST SEVENTH STREET LOS ANGELES, CA 90017
Unable to Locate the Agent for Service of Process?

Reference Information

NAIC #:	18058
NAIC Group #:	<u>3098</u>
California Company ID #:	3576-6
Date authorized in California:	January 27, 1993
License Status:	UNLIMITED-NORMAL
Company Type:	Property & Casualty
State of Domicile:	PENNSYLVANIA

Lines of Insurance Authorized to Transact

The company is authorized to transact business within these lines of insurance. For an explanation of any of these terms, please refer to the glossary.

AUTOMOBILE
BOILER AND MACHINERY
BURGLARY
FIRE
LIABILITY
MARINE
MISCELLANEOUS
PLATE GLASS
SPRINKLER
SURETY

Company Complaint Information

[Company Enforcement Action Documents](#)
[Company Performance & Comparison Data](#)
[Composite Complaint Studies](#)

Want More?

[Help Me Find a Company Representative in My Area](#)

Last Revised - November 10, 2012 10:58 AM
Copyright © California Department of Insurance



CERTIFICATE OF LIABILITY INSURANCE

DATE (MM/DD/YYYY)
3/27/2013

THIS CERTIFICATE IS ISSUED AS A MATTER OF INFORMATION ONLY AND CONFERS NO RIGHTS UPON THE CERTIFICATE HOLDER. THIS CERTIFICATE DOES NOT AFFIRMATIVELY OR NEGATIVELY AMEND, EXTEND OR ALTER THE COVERAGE AFFORDED BY THE POLICIES BELOW. THIS CERTIFICATE OF INSURANCE DOES NOT CONSTITUTE A CONTRACT BETWEEN THE ISSUING INSURER(S), AUTHORIZED REPRESENTATIVE OR PRODUCER, AND THE CERTIFICATE HOLDER.

IMPORTANT: If the certificate holder is an **ADDITIONAL INSURED**, the policy(ies) must be endorsed. If **SUBROGATION IS WAIVED**, subject to the terms and conditions of the policy, certain policies may require an endorsement. A statement on this certificate does not confer rights to the certificate holder in lieu of such endorsement(s).

PRODUCER Alliant Insurance Services, Inc. 1301 Dove Street, Suite 200 Newport Beach CA 92660-2436	CONTACT NAME: Philip Arzu	
	PHONE (A/C, No. Ext): 949-756-0271	FAX (A/C, No): 949-7562713
E-MAIL ADDRESS: parzu@alliant.com		
INSURER(S) AFFORDING COVERAGE		NAIC #
INSURER A: Old Republic General Ins Corp		24139
INSURER B: National Union Fire of PA		19445
INSURER C:		
INSURER D:		
INSURER E:		
INSURER F:		

COVERAGES **CERTIFICATE NUMBER:** 1755017983 **REVISION NUMBER:**

THIS IS TO CERTIFY THAT THE POLICIES OF INSURANCE LISTED BELOW HAVE BEEN ISSUED TO THE INSURED NAMED ABOVE FOR THE POLICY PERIOD INDICATED. NOTWITHSTANDING ANY REQUIREMENT, TERM OR CONDITION OF ANY CONTRACT OR OTHER DOCUMENT WITH RESPECT TO WHICH THIS CERTIFICATE MAY BE ISSUED OR MAY PERTAIN, THE INSURANCE AFFORDED BY THE POLICIES DESCRIBED HEREIN IS SUBJECT TO ALL THE TERMS, EXCLUSIONS AND CONDITIONS OF SUCH POLICIES. LIMITS SHOWN MAY HAVE BEEN REDUCED BY PAID CLAIMS.

INSR LTR	TYPE OF INSURANCE	ADDL INSR	SUBR WVD	POLICY NUMBER	POLICY EFF (MM/DD/YYYY)	POLICY EXP (MM/DD/YYYY)	LIMITS
A	GENERAL LIABILITY <input checked="" type="checkbox"/> COMMERCIAL GENERAL LIABILITY <input type="checkbox"/> CLAIMS-MADE <input checked="" type="checkbox"/> OCCUR	Y	Y	A1CG03661200	6/18/2012	6/18/2013	EACH OCCURRENCE \$1,000,000 DAMAGE TO RENTED PREMISES (Ea occurrence) \$100,000 MED EXP (Any one person) \$5,000 PERSONAL & ADV INJURY \$1,000,000 GENERAL AGGREGATE \$2,000,000 PRODUCTS - COMP/OP AGG \$2,000,000 \$
A	AUTOMOBILE LIABILITY <input checked="" type="checkbox"/> ANY AUTO <input checked="" type="checkbox"/> ALL OWNED AUTOS <input type="checkbox"/> SCHEDULED AUTOS <input checked="" type="checkbox"/> HIRED AUTOS <input checked="" type="checkbox"/> NON-OWNED AUTOS	Y	Y	A1CA03661200	6/18/2012	6/18/2013	COMBINED SINGLE LIMIT (Ea accident) \$1,000,000 BODILY INJURY (Per person) \$ BODILY INJURY (Per accident) \$ PROPERTY DAMAGE (Per accident) \$ \$
B	<input type="checkbox"/> UMBRELLA LIAB <input checked="" type="checkbox"/> OCCUR <input checked="" type="checkbox"/> EXCESS LIAB <input type="checkbox"/> CLAIMS-MADE DED RETENTION \$			BE061234346	6/18/2012	6/18/2013	EACH OCCURRENCE \$8,000,000 AGGREGATE \$8,000,000 \$
A	WORKERS COMPENSATION AND EMPLOYERS' LIABILITY ANY PROPRIETOR/PARTNER/EXECUTIVE OFFICER/MEMBER EXCLUDED? (Mandatory in NH) <input type="checkbox"/> Y/N If yes, describe under DESCRIPTION OF OPERATIONS below		Y	A1CW03661200	6/18/2012	6/18/2013	<input checked="" type="checkbox"/> WC STATUTORY LIMITS <input type="checkbox"/> OTH-ER E.L. EACH ACCIDENT \$1,000,000 E.L. DISEASE - EA EMPLOYEE \$1,000,000 E.L. DISEASE - POLICY LIMIT \$1,000,000

DESCRIPTION OF OPERATIONS / LOCATIONS / VEHICLES (Attach ACORD 101, Additional Remarks Schedule, if more space is required)

Re: Temescal Canyon Road and Dos Lagos Drive Street Improvements Project, El Cerrito Area Adjacent to The City of Corona Project No. C2-0154. A 30 days minimum cancellation notice, with no exceptions or limitations applies to all insurance. The County of Riverside Department of Transportation, the City of Corona, and their respective officers, directors, agents and employees are named additional insured per attached endorsements. Waiver of subrogation applies in favor of the County of Riverside, the City of Corona and their respective officers, directors, agents and employees as per attached endorsements.

CERTIFICATE HOLDER

CANCELLATION

County of Riverside / Dept of Transportation
 Attention: Joel Jimenez
 14th Street Transportation Annex-3525 14th Street
 Riverside CA 92501

SHOULD ANY OF THE ABOVE DESCRIBED POLICIES BE CANCELLED BEFORE THE EXPIRATION DATE THEREOF, NOTICE WILL BE DELIVERED IN ACCORDANCE WITH THE POLICY PROVISIONS.

AUTHORIZED REPRESENTATIVE

THIS ENDORSEMENT CHANGES THE POLICY. PLEASE READ IT CAREFULLY.

**ADDITIONAL INSURED – OWNERS, LESSEES OR
CONTRACTORS – SCHEDULED PERSON OR
ORGANIZATION**

This endorsement modifies insurance provided under the following:

COMMERCIAL GENERAL LIABILITY COVERAGE PART

SCHEDULE

Name Of Additional Insured Person(s) Or Organization(s):	Location(s) Of Covered Operations
WHERE REQUIRED BY WRITTEN CONTRACT.	
Information required to complete this Schedule, if not shown above, will be shown in the Declarations.	

A. Section II – Who Is An Insured is amended to include as an additional insured the person(s) or organization(s) shown in the Schedule, but only with respect to liability for "bodily injury", "property damage" or "personal and advertising injury" caused, in whole or in part, by:

1. Your acts or omissions; or
2. The acts or omissions of those acting on your behalf;

in the performance of your ongoing operations for the additional insured(s) at the location(s) designated above.

B. With respect to the insurance afforded to these additional insureds, the following additional exclusions apply:

This insurance does not apply to "bodily injury" or "property damage" occurring after:

1. All work, including materials, parts or equipment furnished in connection with such work, on the project (other than service, maintenance or repairs) to be performed by or on behalf of the additional insured(s) at the location of the covered operations has been completed; or
2. That portion of "your work" out of which the injury or damage arises has been put to its intended use by any person or organization other than another contractor or subcontractor engaged in performing operations for a principal as a part of the same project.



Authorized Signature

See certificate

Date

THIS ENDORSEMENT CHANGES THE POLICY. PLEASE READ IT CAREFULLY.

**ADDITIONAL INSURED – OWNERS, LESSEES OR
CONTRACTORS – COMPLETED OPERATIONS**

This endorsement modifies insurance provided under the following:

COMMERCIAL GENERAL LIABILITY COVERAGE PART

SCHEDULE

Name Of Additional Insured Person(s) Or Organization(s):	Location And Description Of Completed Operations
<p>WHERE REQUIRED BY WRITTEN CONTRACT, BUT ONLY WHEN COVERAGE FOR COMPLETED OPERATIONS IS SPECIFICALLY REQUIRED BY THAT CONTRACT.</p>	
<p>Information required to complete this Schedule, if not shown above, will be shown in the Declarations.</p>	

Section II – Who Is An Insured is amended to include as an additional insured the person(s) or organization(s) shown in the Schedule, but only with respect to liability for "bodily injury" or "property damage" caused, in whole or in part, by "your work" at the location designated and described in the schedule of this endorsement performed for that additional insured and included in the "products-completed operations hazard".

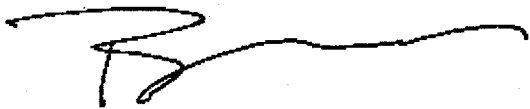

Authorized Signature

See certificate

Date

OLD REPUBLIC GENERAL INSURANCE CORPORATION

CHANGES ADDITIONAL INSURED PRIMARY WORDING SCHEDULE

THIS ENDORSEMENT CHANGES THE POLICY. PLEASE READ IT CAREFULLY.

THIS ENDORSEMENT MODIFIES INSURANCE PROVIDED UNDER THE FOLLOWING:

COMMERCIAL GENERAL LIABILITY COVERAGE FORM

Name of Additional Insured Person(s)
Or Organization(s):

Location(s) of Covered Operations

As required by written contract.

Information required to complete this Schedule, if not shown above, will be shown in the Declarations.

The insurance provided by this endorsement is primary insurance and we will not seek contribution from any other insurance of a like kind available to the person or organization shown in the schedule above unless the other insurance is provided by a contractor other than the person or organization shown in the schedule above for the same operation and job location. If so, we will share with that other insurance by the method described in paragraph 4.c. of Section IV – Commercial General Liability Conditions.

All other terms and conditions remain unchanged.

Named Insured	Mamco, Inc.		
Policy Number	A1CG03661200	Endorsement No.	000
Policy Period	6/18/2012 to 6/18/2013	Endorsement Effective Date:	6/18/2012
Producer's Name:	Alliant Insurance Services, Inc.		
Producer Number:			



AUTHORIZED REPRESENTATIVE

See certificate

DATE

THIS ENDORSEMENT CHANGES THE POLICY. PLEASE READ IT CAREFULLY.

**DESIGNATED CONSTRUCTION PROJECT(S)
GENERAL AGGREGATE LIMIT**

This endorsement modifies insurance provided under the following:

COMMERCIAL GENERAL LIABILITY COVERAGE PART

SCHEDULE

Designated Construction Project(s):

ALL OF YOUR DESIGNATED CONSTRUCTION PROJECTS.

Information required to complete this Schedule, if not shown above, will be shown in the Declarations.

- A. For all sums which the insured becomes legally obligated to pay as damages caused by "occurrences" under Section I – Coverage A, and for all medical expenses caused by accidents under Section I – Coverage C, which can be attributed only to ongoing operations at a single designated construction project shown in the Schedule above:
1. A separate Designated Construction Project General Aggregate Limit applies to each designated construction project, and that limit is equal to the amount of the General Aggregate Limit shown in the Declarations.
 2. The Designated Construction Project General Aggregate Limit is the most we will pay for the sum of all damages under Coverage A, except damages because of "bodily injury" or "property damage" included in the "products-completed operations hazard", and for medical expenses under Coverage C regardless of the number of:
 - a. Insureds;
 - b. Claims made or "suits" brought; or
 - c. Persons or organizations making claims or bringing "suits".
 3. Any payments made under Coverage A for damages or under Coverage C for medical expenses shall reduce the Designated Construction Project General Aggregate Limit for that designated construction project. Such payments shall not reduce the General Aggregate Limit shown in the Declarations nor shall they reduce any other Designated Construction Project General Aggregate Limit for any other designated construction project shown in the Schedule above.
 4. The limits shown in the Declarations for Each Occurrence, Damage To Premises Rented To You and Medical Expense continue to apply. However, instead of being subject to the General Aggregate Limit shown in the Declarations, such limits will be subject to the applicable Designated Construction Project General Aggregate Limit.

B. For all sums which the insured becomes legally obligated to pay as damages caused by "occurrences" under Section I – Coverage A, and for all medical expenses caused by accidents under Section I – Coverage C, which cannot be attributed only to ongoing operations at a single designated construction project shown in the Schedule above:

- 1. Any payments made under Coverage A for damages or under Coverage C for medical expenses shall reduce the amount available under the General Aggregate Limit or the Products-completed Operations Aggregate Limit, whichever is applicable; and**
- 2. Such payments shall not reduce any Designated Construction Project General Aggregate Limit.**

C. When coverage for liability arising out of the "products-completed operations hazard" is provided, any payments for damages because of "bodily injury" or "property damage" included in the "products-completed operations hazard" will reduce the Products-completed Operations Aggregate Limit, and not reduce the General Aggregate Limit nor the Designated Construction Project General Aggregate Limit.

D. If the applicable designated construction project has been abandoned, delayed, or abandoned and then restarted, or if the authorized contracting parties deviate from plans, blueprints, designs, specifications or timetables, the project will still be deemed to be the same construction project.

E. The provisions of Section III – Limits Of Insurance not otherwise modified by this endorsement shall continue to apply as stipulated.



Authorized Signature

See certificate

Date

WAIVER OF TRANSFER OF RIGHTS OF RECOVERY AGAINST OTHERS TO US

This endorsement modifies insurance provided under the following:

COMMERCIAL GENERAL LIABILITY COVERAGE PART
PRODUCTS/COMPLETED OPERATIONS LIABILITY COVERAGE PART

SCHEDULE

Name Of Person Or Organization:

WHERE REQUIRED BY WRITTEN CONTRACT.

Information required to complete this Schedule, if not shown above, will be shown in the Declarations.

The following is added to Paragraph 8. Transfer Of Rights Of Recovery Against Others To Us of Section IV - Conditions:

We waive any right of recovery we may have against the person or organization shown in the Schedule above because of payments we make for injury or damage arising out of your ongoing operations or "your work" done under a contract with that person or organization and included in the "products-completed operations hazard". This waiver applies only to the person or organization shown in the Schedule above.



Authorized Signature

See certificate

Date

OLD REPUBLIC GENERAL INSURANCE CORPORATION

ADDITIONAL INSURED WHERE REQUIRED UNDER CONTRACT OR AGREEMENT

THIS ENDORSEMENT CHANGES THE POLICY. PLEASE READ IT CAREFULLY.

THIS ENDORSEMENT MODIFIES INSURANCE PROVIDED UNDER THE FOLLOWING:

BUSINESS AUTO COVERAGE FORM

The following is added to Section II – Liability Coverage, A. – Coverage, 1. Who Is An Insured:

- d. Any person or organization to whom you become obligated to include as an additional insured under this policy, as a result of any contract or agreement you enter into which required you to furnish insurance to that person or organization of the type provided by this policy, but only with respect to liability arising out of your operations or premises owned by or rented to you. However, the insurance provided will not exceed the lessor of:
1. The coverage or limits of this policy, or
 2. The coverage or limits required by said contract or agreement.

Named Insured	Mamco, Inc.		
Policy Number	A1CA03661200	Endorsement No.	000
Policy Period	6/18/2012 to 6/18/2013	Endorsement Effective Date:	6/18/2012
Producer's Name:	Alliant Insurance Services, Inc.		
Producer Number:			



AUTHORIZED REPRESENTATIVE

See certificate

DATE

CA EN GN 0020 03 07

OLD REPUBLIC GENERAL INSURANCE CORPORATION

AMENDMENT OF OTHER INSURANCE

THIS ENDORSEMENT CHANGES THE POLICY. PLEASE READ IT CAREFULLY.

THIS ENDORSEMENT MODIFIES INSURANCE PROVIDED UNDER THE FOLLOWING:

BUSINESS AUTO COVERAGE FORM

Section IV – Business Auto Conditions, B. – General Conditions, 5. – Other Insurance, a. is replaced by the following:

- a. For any covered "auto" you own, this Coverage Form provides primary insurance. However, if there is other collectible insurance, the insurance provided by this Coverage Form with respect to such covered auto, is excess over such other collectible insurance. For any covered "auto" you don't own, the insurance provided by this Coverage Form is excess over any other collectible insurance. However, while a covered "auto" which is a "trailer" is connected to another vehicle, the Liability Coverage this Coverage Form provides for the "trailer" is:
- (1) Excess while it is connected to a motor vehicle you do not own;
 - (2) Primary while it is connected to a covered "auto" you own. However, if there is other collectible insurance with respect to such "trailer," the insurance provided by this Coverage Form is excess over such other collectible insurance.

Named Insured	Mamco, Inc.		
Policy Number	A1CA03661200	Endorsement No.	000
Policy Period	6/18/2012 6/18/2013	to Endorsement Effective Date:	6/18/2012
Producer's Name:	Alliant Insurance Services, Inc.		
Producer Number:			

AUTHORIZED REPRESENTATIVE

See certificate

DATE

POLICY NUMBER: A-1CA-036612-00

COMMERCIAL AUTO
CA 04 44 03 10

THIS ENDORSEMENT CHANGES THE POLICY. PLEASE READ IT CAREFULLY.

**WAIVER OF TRANSFER OF RIGHTS OF RECOVERY
AGAINST OTHERS TO US (WAIVER OF SUBROGATION)**

This endorsement modifies insurance provided under the following:

BUSINESS AUTO COVERAGE FORM
BUSINESS AUTO PHYSICAL DAMAGE COVERAGE FORM
GARAGE COVERAGE FORM
MOTOR CARRIER COVERAGE FORM
TRUCKERS COVERAGE FORM

With respect to coverage provided by this endorsement, the provisions of the Coverage Form apply unless modified by the endorsement.

This endorsement changes the policy effective on the inception date of the policy unless another date is indicated below.

Named Insured: MAMCO, INC.

Endorsement Effective Date: 06-18-12

SCHEDULE

Name(s) Of Person(s) Or Organization(s):

WHERE REQUIRED BY WRITTEN CONTRACT.

Information required to complete this Schedule, if not shown above, will be shown in the Declarations.

The Transfer Of Rights Of Recovery Against Others To Us Condition does not apply to the person(s) or organization(s) shown in the Schedule, but only to the extent that subrogation is waived prior to the "accident" or the "loss" under a contract with that person or organization.

Authorized Signature

See certificate

Date

OLD REPUBLIC GENERAL INSURANCE CORPORATION
WORKERS COMPENSATION AND EMPLOYERS LIABILITY INSURANCE POLICY
WAIVER OF OUR RIGHT TO RECOVER FROM OTHERS ENDORSEMENT

THIS ENDORSEMENT CHANGES THE POLICY. PLEASE READ IT CAREFULLY.

THIS ENDORSEMENT MODIFIES INSURANCE PROVIDED UNDER THE FOLLOWING:

We have the right to recover our payments from anyone liable for an injury covered by this policy. We will not enforce our right against the person or organization named in the Schedule. This agreement applies only to the extent that you perform work under a written contract that requires you to obtain this agreement from us.

This agreement shall not operate directly or indirectly to benefit anyone not named in the Schedule.

Schedule

WHEN REQUIRED BY WRITTEN CONTRACT.

The premium charge for this endorsement is \$0.00

Named Insured	MAMCO, INC.		
Policy Number	A-1CW-036612-00	Endorsement No.	000
Policy Period	06/18/2012 to 06/18/2013	Endorsement Effective Date:	06/18/2012
Producer's Name:	OLD REPUBLIC CONSTRUCTION INSURANCE AGENCY, INC.		
Producer Number:	0000007000		



AUTHORIZED REPRESENTATIVE

See certificate

DATE

**Prime ExpressSM
Commercial Excess Liability Policy With CrisisResponse[®]**

Various provisions in this policy restrict coverage. Read the entire policy carefully to determine rights, duties and what is and is not covered.

Throughout this policy the words "you" and "your" refer to the **Named Insured** shown in the Declarations and any other person or organization qualifying as a **Named Insured** under this policy. The words "we," "us" and "our" refer to the company providing this insurance.

The word **Insured** means any person or organization qualifying as such under Section VII. Definitions.

Except for headings, words that appear in bold print have special meaning. See Section VII. Definitions.

In consideration of the payment of the premium and in reliance upon the statements in the Declarations, we agree to provide coverage as follows:

I. INSURING AGREEMENT - COMMERCIAL EXCESS LIABILITY

A. We will pay on behalf of the **Insured** those sums in excess of the **Retained Limit** that the **Insured** becomes legally obligated to pay as damages by reason of liability imposed by law because of **Bodily Injury, Property Damage or Personal Injury and Advertising Injury** to which this insurance applies or because of **Bodily Injury or Property Damage** to which this insurance applies assumed by the **Insured** under an **Insured Contract**. Coverage under this policy will follow the terms, definitions, conditions and exclusions of **Scheduled Underlying Insurance**, subject to the **Policy Period, Limits of Insurance, premium** and all other terms, definitions, conditions and exclusions of this policy. Provided, however, that coverage provided by this policy will not be broader than the coverage provided by the policy listed in **Scheduled Underlying Insurance**.

The amount we will pay for damages is limited as described in Section IV. Limits of Insurance.

B. This policy applies, only if:

1. the **Bodily Injury or Property Damage** is caused by an **Occurrence** that takes place anywhere, and the **Bodily Injury or Property Damage** occurs during the **Policy Period**; and
 2. the **Personal Injury and Advertising Injury** is caused by an **Occurrence** that takes place anywhere arising out of your business, but only if the **Occurrence** was committed during the **Policy Period**.
- C. 1. This policy applies to **Bodily Injury or Property Damage**, only if prior to the **Policy Period**, no **Insured** listed under subparagraphs 2a., 2b., 2c. or 2e. of Paragraph N. of Section VII, no executive officer or director listed under subparagraph 2d. of Paragraph N. of Section VII, and no employee authorized by you to give or receive notice of an **Occurrence, claim or Suit**, knew that the **Bodily Injury or Property Damage** had occurred, in whole or in part. If such an **Insured, or authorized employee** knew, prior to the **Policy Period**, that the **Bodily Injury or Property Damage** had occurred, then any continuation, change or resumption of such **Bodily Injury or Property Damage** during or after the **Policy Period** will be deemed to have been known prior to the **Policy Period**.
2. **Bodily Injury or Property Damage** which occurs during the **Policy Period** and was not, prior to the **Policy Period**, known to have occurred by any **Insured** listed under subparagraphs 2a., 2b., 2c. or 2e. of Paragraph N. of Section VII., any executive officer or director listed under subparagraph 2d. of Paragraph N. of Section VII. or any employee authorized by you to give or receive notice of an **Occurrence or claim**, includes any continuation, change or resumption of that **Bodily Injury or Property Damage** after the end of the **Policy Period**.

Authorized Signature

90269 (11/09)
AH2711

See certificate

Date

Company Profile

OLD REPUBLIC GENERAL INSURANCE CORPORATION

307 N MICHIGAN AVE 17TH FL

CHICAGO, IL 60601-5382

800-331-5554

Former Names for Company

Old Name: INTERNATIONAL BUSINESS & MERCANTILE REASSURANCE COMPANY

Effective Date: 12-14-2006

Old Name: MOTORISTS BENEFICIAL INSURANCE COMPANY

Effective Date: 04-21-1982

Agent for Service of Process

KAREN HARRIS, C/O CORPORATION SERVICE COMPANY 2710 GATEWAY OAKS DRIVE, SUITE 150N SACRAMENTO, CA 95833-3505

Unable to Locate the Agent for Service of Process?

Reference Information

NAIC #:	24139
NAIC Group #:	0150
California Company ID #:	1800-2
Date authorized in California:	June 30, 1965
License Status:	UNLIMITED-NORMAL
Company Type:	Property & Casualty
State of Domicile:	ILLINOIS

Lines of Insurance Authorized to Transact

The company is authorized to transact business within these lines of insurance. For an explanation of any of these terms, please refer to the glossary.

AUTOMOBILE
BOILER AND MACHINERY
BURGLARY
COMMON CARRIER LIABILITY
DISABILITY
FIRE
LIABILITY
MARINE
MISCELLANEOUS
PLATE GLASS
SPRINKLER
SURETY
TEAM AND VEHICLE
WORKERS' COMPENSATION

Company Complaint Information

[Company Enforcement Action Documents](#)

[Company Performance & Comparison Data](#)

[Composite Complaint Studies](#)

Want More?

[Help Me Find a Company Representative in My Area](#)

Last Revised - November 10, 2012 10:58 AM
Copyright © California Department of Insurance

Company Profile

**NATIONAL UNION FIRE INSURANCE COMPANY OF
PITTSBURGH, PA
180 MAIDEN LANE
NEW YORK, NY 10038
800-551-0824**

Agent for Service of Process

KAREN HARRIS, C/O CORPORATION SERVICE COMPANY 2710 GATEWAY OAKS DRIVE, SUITE 150N SACRAMENTO, CA 95833-3505

Unable to Locate the Agent for Service of Process?

Reference Information

NAIC #:	19445
NAIC Group #:	0012
California Company ID #:	0131-3
Date authorized in California:	November 28, 1902
License Status:	UNLIMITED-NORMAL
Company Type:	Property & Casualty
State of Domicile:	PENNSYLVANIA

Lines of Insurance Authorized to Transact

The company is authorized to transact business within these lines of insurance. For an explanation of any of these terms, please refer to the glossary.

AIRCRAFT
AUTOMOBILE
BOILER AND MACHINERY
BURGLARY
COMMON CARRIER LIABILITY
DISABILITY
FIRE
LIABILITY
MARINE
MISCELLANEOUS
PLATE GLASS
SPRINKLER
SURETY
TEAM AND VEHICLE
WORKERS' COMPENSATION

Company Complaint Information

[Company Enforcement Action Documents](#)
[Company Performance & Comparison Data](#)
[Composite Complaint Studies](#)

Want More?

[Help Me Find a Company Representative in My Area](#)

Last Revised - November 10, 2012 10:58 AM
Copyright © California Department of Insurance

Attachment "A"

Riverside County Transportation Department

Project: **Temescal Canyon Road and Dos Lagos Drive**

Project No.(s): **C2-0154**

Expenses as of: 2/28/13

Project Costs and Budget

Activity	Incurred Costs	Projected Costs	Total Costs	Existing Budget
Preliminary Survey	14,188		14,188	22,000
Environmental	1,635		1,635	5,000
Design	105,459		105,459	81,000
Right-of-way	477,030		478,000	478,000
Utilities				
Construction	36,960	269,000	332,860	352,000
Construction Contingency 10.0%		26,900		
Construction Engineering & Inspection	7,239	50,000	57,239	55,000
Construction Survey	6,507	17,000	23,507	20,000
Totals:	649,018	362,900	1,012,888	1,013,000

Project Funding

Code	Name	Existing Budget
201	Gas Tax - Prop 111	463,000
221	Gas Tax (ABX8-9 Mar 2010 New HUTA)	550,000
Totals		1,013,000

Comments

COUNTY OF RIVERSIDE
DEPARTMENT OF TRANSPORTATION

TEMESCAL CANYON ROAD
AND
DOS LAGOS DRIVE
STREET IMPROVEMENTS PROJECT
EL CERRITO AREA ADJACENT TO THE CITY OF CORONA
PROJECT NO. C2-0154

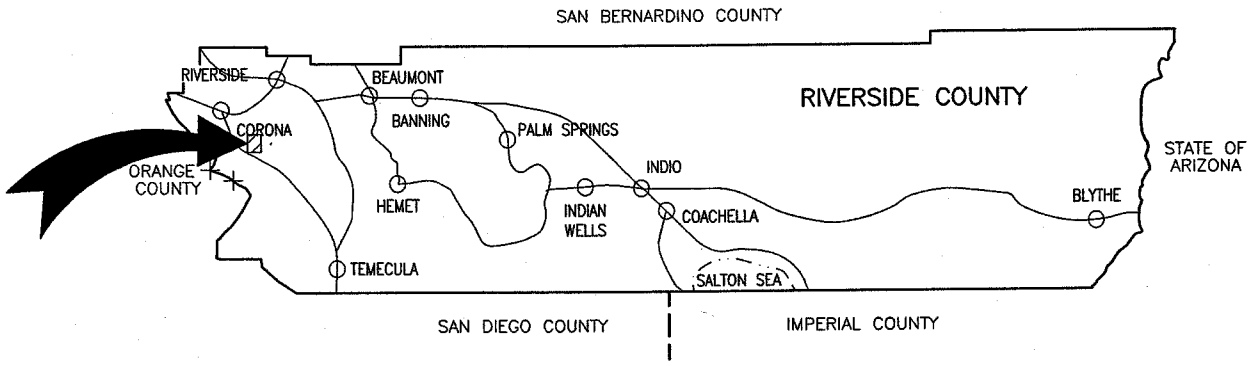

INDEX MAP

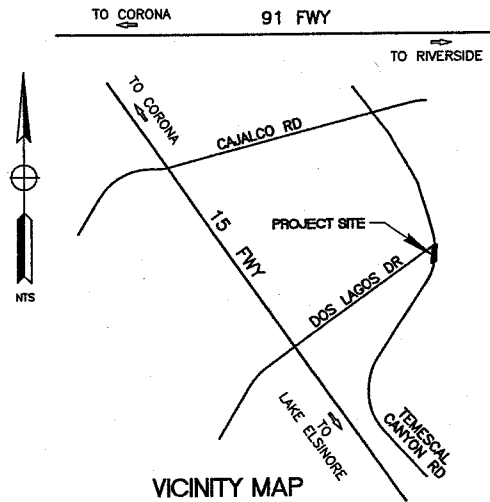

VICINITY MAP
TOWNSHIP 4S RANGE 6W SECTION 21
COUNTY ROAD BOOK PAGE No. 33A

**Riverside County Transportation Department
Summary of Bids**

Advertised: January 29, 2013 (Agenda Item: 3.44)
Addenda: One (2/14/2013), Two (2/20/2013), Three (2/21/2013), Four (2/25/2013)
Bids Open: 2 pm Date: Wednesday, February 27, 2013

**PROJECT: Temescal Canyon Road and Dos Lagos Drive
Street Improvements Project
El Cerrito Area Adjacent to the City of Corona
PROJECT No. C2-0154**

BASE BID		COUNTY'S ESTIMATE									
ITEM NO.	ITEM CODE	CONTRACT ITEM	UNITS	QUANTITY	UNIT PRICE	ENG ESTIMATE	BID UNIT PRICE	BID ESTIMATE			
1	066102	DUST ABATEMENT	LS	1	3,000.00	3,000.00	5,949.75	5,949.75			
2	074020	WATER POLLUTION CONTROL	LS	1	5,000.00	5,000.00	4,300.00	4,300.00			
3	120100	TRAFFIC CONTROL SYSTEM	LS	1	5,000.00	5,000.00	18,100.00	18,100.00			
4	160101	CLEARING AND GRUBBING	LS	1	10,000.00	10,000.00	18,500.00	18,500.00			
5	170101	DEVELOP WATER SUPPLY	LS	1	3,000.00	3,000.00	540.00	540.00			
6	190101	ROADWAY EXCAVATION	CY	655	40.00	26,200.00	16.00	10,480.00			
7	731521	MINOR CONCRETE (SIDEWALK) (INCLUDING 12" HIGH AND 6" WIDE CONCRETE CURB BEHIND SIDEWALK)	SQFT	5,000	5.00	25,000.00	3.90	19,500.00			
8	017305	MINOR CONCRETE (CURB AND GUTTER) (CRS 201)	LF	500	20.00	10,000.00	16.50	8,250.00			
9	017312	MINOR CONCRETE (COMERCIAL DRIVEWAY) (CRS 207A)	EA	4	2,000.00	8,000.00	5,900.00	23,600.00			
10	260201	CLASS 2 AGGREGATE BASE	CY	450	35.00	15,750.00	34.00	15,300.00			
11	390130	HOT MIX ASPHALT	TON	750	80.00	60,000.00	78.00	58,500.00			
12	650014	18" REINFORCED CONCRETE PIPE	LF	86	90.00	7,740.00	80.00	6,880.00			
13	650018	24" REINFORCED CONCRETE PIPE	LF	20	150.00	3,000.00	110.00	2,200.00			
14	153103	COLD PLANE ASPHALT CONCRETE PAVEMENT	SQYD	2,355	2.00	4,710.00	3.00	7,065.00			
15	800320	CHAIN LINK FENCE (TYPE CL-4)	LF	175	30.00	5,250.00	14.00	2,450.00			
16	800360	CHAIN LINK FENCE (TYPE CL-6) (INCLUDING GATE)	LF	340	40.00	13,600.00	24.00	8,160.00			
17	017110	MANHOLE (RCFC & WCDS MH 254)	EA	1	5,000.00	5,000.00	4,375.00	4,375.00			
18	017003	CATCH BASIN (CURB INLET) (CRS 300)	EA	2	4,000.00	8,000.00	4,727.00	9,454.00			
19	840515	THERMOPLASTIC PAVEMENT MARKING	SQFT	285	10.00	2,850.00	5.25	1,496.25			
20	566011	ROADSIDE SIGN - ONE POST	EA	2	300.00	600.00	262.00	524.00			
21	840656	PAINT TRAFFIC STRIPE (2-COAT)	LF	3,800	0.75	2,850.00	0.52	1,976.00			
22	019901	DEMOBILIZATION	LS	1	10,000.00	10,000.00	10,000.00	10,000.00			
23	394002	PLACE ASPHALT CONCRETE (MISCELLANEOUS AREA)	SQYD	200	30.00	6,000.00	32.00	6,400.00			
24	010602	MISCELLANEOUS WORK (AS DIRECTED)	FA	1	25,000.00	25,000.00	25,000.00	25,000.00			
Project Total Items 1-24							265,550.00	269,000.00			

**Riverside County Transportation Department
Summary of Bids**

**PROJECT: Temescal Canyon Road and Dos Lagos Drive
Street Improvements Project
El Cerrito Area Adjacent to the City of Corona**

**Advertised: January 29, 2013 (Agenda Item: 3.44)
Addenda: One (2/14/2013), Two (2/20/2013), Three (2/21/2013), Four (2/25/2013)
Bids Open: 2 pm Date: Wednesday, February 27, 2013**

PROJECT No. C2-0154

BASE BID		2		3				
ITEM NO.	ITEM CODE	CONTRACT ITEM	UNITS	QUANTITY	BID UNIT PRICE	BID ESTIMATE	BID UNIT PRICE	BID ESTIMATE
1	066102	DUST ABATEMENT	LS	1	2,800.00	2,800.00	1,000.00	1,000.00
2	074020	WATER POLLUTION CONTROL	LS	1	3,000.00	3,000.00	1,000.00	1,000.00
3	120100	TRAFFIC CONTROL SYSTEM	LS	1	6,300.00	6,300.00	4,500.00	4,500.00
4	160101	CLEARING AND GRUBBING	LS	1	4,400.00	4,400.00	3,500.00	3,500.00
5	170101	DEVELOP WATER SUPPLY	LS	1	1,900.00	1,900.00	1,000.00	1,000.00
6	190101	ROADWAY EXCAVATION	CY	655	49.00	32,095.00	40.00	26,200.00
7	731521	MINOR CONCRETE (SIDEWALK) (INCLUDING 12" HIGH AND 6" WIDE CONCRETE CURB BEHIND SIDEWALK)	SQFT	5,000	5.00	25,000.00	6.61	33,050.00
8	017305	MINOR CONCRETE (CURB AND GUTTER) (CRS 201)	LF	500	43.00	21,500.00	17.80	8,900.00
9	017312	MINOR CONCRETE (COMMERCIAL DRIVEWAY) (CRS 207A)	EA	4	1,500.00	6,000.00	4,485.00	17,940.00
10	260201	CLASS 2 AGGREGATE BASE	CY	450	23.00	10,350.00	31.10	13,995.00
11	390130	HOT MIX ASPHALT	TON	750	67.00	50,250.00	83.00	62,250.00
12	650014	18" REINFORCED CONCRETE PIPE	LF	86	159.00	13,674.00	240.00	20,640.00
13	650018	24" REINFORCED CONCRETE PIPE	LF	20	312.00	6,240.00	316.00	6,320.00
14	153103	COLD PLANE ASPHALT CONCRETE PAVEMENT	SQYD	2,355	3.00	7,065.00	5.00	11,775.00
15	800320	CHAIN LINK FENCE (TYPE CL-4)	LF	175	23.00	4,025.00	23.00	4,025.00
16	800360	CHAIN LINK FENCE (TYPE CL-6) (INCLUDING GATE)	LF	340	26.00	8,840.00	28.75	9,775.00
17	017110	MANHOLE (RCFC & WCDS MH 254)	EA	1	12,000.00	12,000.00	900.00	900.00
18	017003	CATCH BASIN (CURB INLET) (CRS 300)	EA	2	5,795.00	11,590.00	7,100.00	14,200.00
19	840515	THERMOPLASTIC PAVEMENT MARKING	SQFT	285	6.00	1,710.00	5.00	1,425.00
20	566011	ROADSIDE SIGN - ONE POST	EA	2	316.00	632.00	316.00	632.00
21	840656	PAINT TRAFFIC STRIPE (2-COAT)	LF	3,800	1.58	6,004.00	0.50	1,900.00
22	019901	DEMobilIZATION	LS	1	10,000.00	10,000.00	10,000.00	10,000.00
23	394002	PLACE ASPHALT CONCRETE (MISCELLANEOUS AREA)	SQYD	200	32.00	6,400.00	22.50	4,500.00
24	010602	MISCELLANEOUS WORK (AS DIRECTED)	FA	1	25,000.00	25,000.00	25,000.00	25,000.00
Project Total Items 1-24						276,775.00		284,427.00

**Riverside County Transportation Department
Summary of Bids**

**PROJECT: Temescal Canyon Road and Dos Lagos Drive
Street Improvements Project
El Cerrito Area Adjacent to the City of Corona**

**Advertised: January 29, 2013 (Agenda Item: 3.44)
Addenda: One (2/14/2013), Two (2/20/2013), Three (2/21/2013), Four (2/25/2013)
Bids Open: 2 pm Date: Wednesday, February 27, 2013**

PROJECT No. C2-0154

BASE BID		4		5				
ITEM NO.	ITEM CODE	CONTRACT ITEM	UNITS	QUANTITY	BID UNIT PRICE	BID ESTIMATE	BID UNIT PRICE	BID ESTIMATE
1	066102	DUST ABATEMENT	LS	1	3,000.00	3,000.00	8,000.00	8,000.00
2	074020	WATER POLLUTION CONTROL	LS	1	6,000.00	6,000.00	2,500.00	2,500.00
3	120100	TRAFFIC CONTROL SYSTEM	LS	1	9,800.00	9,800.00	7,500.00	7,500.00
4	160101	CLEARING AND GRUBBING	LS	1	10,000.00	10,000.00	7,000.00	7,000.00
5	170101	DEVELOP WATER SUPPLY	LS	1	3,000.00	3,000.00	800.00	800.00
6	190101	ROADWAY EXCAVATION	CY	655	38.60	25,283.00	34.00	22,270.00
7	731521	MINOR CONCRETE (SIDEWALK) (INCLUDING 12" HIGH AND 6" WIDE CONCRETE CURB BEHIND SIDEWALK)	SQFT	5,000	3.40	17,000.00	4.25	21,250.00
8	017305	MINOR CONCRETE (CURB AND GUTTER) (CRS 201)	LF	500	21.70	10,850.00	21.50	10,750.00
9	017312	MINOR CONCRETE (COMMERCIAL DRIVEWAY) (CRS 207A)	EA	4	5,800.00	23,200.00	6,100.00	24,400.00
10	260201	CLASS 2 AGGREGATE BASE	CY	450	27.00	12,150.00	41.00	18,450.00
11	390130	HOT MIX ASPHALT	TON	750	81.00	60,750.00	78.00	58,500.00
12	650014	18" REINFORCED CONCRETE PIPE	LF	86	132.00	11,352.00	190.00	16,340.00
13	650018	24" REINFORCED CONCRETE PIPE	LF	20	264.00	5,280.00	200.00	4,000.00
14	153103	COLD PLANE ASPHALT CONCRETE PAVEMENT	SQYD	2,355	4.70	11,068.50	3.15	7,418.25
15	800320	CHAIN LINK FENCE (TYPE CL-4)	LF	175	15.70	2,747.50	22.50	3,937.50
16	800360	CHAIN LINK FENCE (TYPE CL-6) (INCLUDING GATE)	LF	340	24.30	8,262.00	25.00	8,500.00
17	017110	MANHOLE (RCFC & WCDS MH 254)	EA	1	7,200.00	7,200.00	9,700.00	9,700.00
18	017003	CATCH BASIN (CURB INLET) (CRS 300)	EA	2	7,800.00	15,600.00	10,000.00	20,000.00
19	840515	THERMOPLASTIC PAVEMENT MARKING	SQFT	285	4.70	1,339.50	5.20	1,482.00
20	566011	ROADSIDE SIGN - ONE POST	EA	2	290.00	580.00	260.00	520.00
21	840656	PAINT TRAFFIC STRIPE (2-COAT)	LF	3,800	0.51	1,938.00	0.52	1,976.00
22	019901	DEMOBILIZATION	LS	1	10,000.00	10,000.00	10,000.00	10,000.00
23	394002	PLACE ASPHALT CONCRETE (MISCELLANEOUS AREA)	SQYD	200	21.80	4,360.00	35.00	7,000.00
24	010602	MISCELLANEOUS WORK (AS DIRECTED)	FA	1	25,000.00	25,000.00	25,000.00	25,000.00

Project Total						285,760.50		297,293.75
Items 1-24								

**Riverside County Transportation Department
Summary of Bids**

**PROJECT: Temescal Canyon Road and Dos Lagos Drive
Street Improvements Project
El Cerrito Area Adjacent to the City of Corona**

**Advertised: January 29, 2013 (Agenda Item: 3.44)
Addenda: One (2/14/2013), Two (2/20/2013), Three (2/21/2013), Four (2/25/2013)
Bids Open: 2 pm Date: Wednesday, February 27, 2013**

PROJECT No. C2-0154

BASE BID ITEM NO.	ITEM CODE	CONTRACT ITEM	UNITS	6		7	
				BID UNIT PRICE	BID ESTIMATE	BID UNIT PRICE	BID ESTIMATE
1	066102	DUST ABATEMENT	LS	3,000.00	3,000.00	3,000.00	3,000.00
2	074020	WATER POLLUTION CONTROL	LS	5,250.00	5,250.00	3,000.00	3,000.00
3	120100	TRAFFIC CONTROL SYSTEM	LS	20,582.00	20,582.00	5,000.00	5,000.00
4	160101	CLEARING AND GRUBBING	LS	10,000.00	10,000.00	10,000.00	10,000.00
5	170101	DEVELOP WATER SUPPLY	LS	3,000.00	3,000.00	3,000.00	3,000.00
6	190101	ROADWAY EXCAVATION	CY	50.00	32,750.00	40.00	26,200.00
7	731521	MINOR CONCRETE (SIDEWALK) (INCLUDING 12" HIGH AND 6" WIDE CONCRETE CURB BEHIND SIDEWALK)	SQFT	6.10	30,500.00	4.30	21,500.00
8	017305	MINOR CONCRETE (CURB AND GUTTER) (CRS 201)	LF	20.00	10,000.00	28.00	14,000.00
9	017312	MINOR CONCRETE (COMERCIAL DRIVEWAY) (CRS 207A)	EA	2,600.00	10,400.00	7,000.00	28,000.00
10	260201	CLASS 2 AGGREGATE BASE	CY	40.00	18,000.00	29.00	13,050.00
11	390130	HOT MIX ASPHALT	TON	80.00	60,000.00	77.00	57,750.00
12	650014	18" REINFORCED CONCRETE PIPE	LF	72.00	6,192.00	95.00	8,170.00
13	650018	24" REINFORCED CONCRETE PIPE	LF	100.00	2,000.00	350.00	7,000.00
14	153103	COLD PLANE ASPHALT CONCRETE PAVEMENT	SQYD	2.30	5,416.50	5.00	11,775.00
15	800320	CHAIN LINK FENCE (TYPE CL-4)	LF	22.00	3,850.00	16.50	2,887.50
16	800360	CHAIN LINK FENCE (TYPE CL-6) (INCLUDING GATE)	LF	25.00	8,500.00	27.00	9,180.00
17	017110	MANHOLE (RCFC & WCDS MH 254)	EA	5,700.00	5,700.00	8,000.00	8,000.00
18	017003	CATCH BASIN (CURB INLET) (CRS 300)	EA	10,200.00	20,400.00	10,300.00	20,600.00
19	840515	THERMOPLASTIC PAVEMENT MARKING	SQFT	5.40	1,539.00	5.00	1,425.00
20	566011	ROADSIDE SIGN - ONE POST	EA	260.00	520.00	260.00	520.00
21	840656	PAINT TRAFFIC STRIPE (2-COAT)	LF	0.50	1,900.00	0.50	1,900.00
22	019901	DEMobilIZATION	LS	10,000.00	10,000.00	10,000.00	10,000.00
23	394002	PLACE ASPHALT CONCRETE (MISCELLANEOUS AREA)	SQYD	26.00	5,200.00	50.00	10,000.00
24	010602	MISCELLANEOUS WORK (AS DIRECTED)	FA	25,000.00	25,000.00	25,000.00	25,000.00

Project Total Items 1-24				299,699.50	300,957.50
-------------------------------------	--	--	--	-------------------	-------------------

**Riverside County Transportation Department
Summary of Bids**

**PROJECT: Temescal Canyon Road and Dos Lagos Drive
Street Improvements Project
El Cerrito Area Adjacent to the City of Corona**

**Advertised: January 29, 2013 (Agenda Item: 3.44)
Addenda: One (2/14/2013), Two (2/20/2013), Three (2/21/2013), Four (2/25/2013)
Bids Open: 2 pm Date: Wednesday, February 27, 2013**

PROJECT No. C2-0154

BASE BID ITEM NO.	ITEM CODE	CONTRACT ITEM	UNITS	QUANTITY	8		9	
					BID UNIT PRICE	BID ESTIMATE	BID UNIT PRICE	BID ESTIMATE
1	066102	DUST ABATEMENT	LS	1	1,300.00	1,300.00	944.00	944.00
2	074020	WATER POLLUTION CONTROL	LS	1	7,300.00	7,300.00	2,950.00	2,950.00
3	120100	TRAFFIC CONTROL SYSTEM	LS	1	14,000.00	14,000.00	7,500.00	7,500.00
4	160101	CLEARING AND GRUBBING	LS	1	14,300.00	14,300.00	7,000.00	7,000.00
5	170101	DEVELOP WATER SUPPLY	LS	1	1,380.00	1,380.00	2,950.00	2,950.00
6	190101	ROADWAY EXCAVATION	CY	655	78.75	51,581.25	47.00	30,785.00
7	731521	MINOR CONCRETE (SIDEWALK) (INCLUDING 12" HIGH AND 6" WIDE CONCRETE CURB BEHIND SIDEWALK)	SQFT	5,000	3.50	17,500.00	10.00	50,000.00
8	017305	MINOR CONCRETE (CURB AND GUTTER) (CRS 201)	LF	500	22.30	11,150.00	21.00	10,500.00
9	017312	MINOR CONCRETE (COMMERCIAL DRIVEWAY) (CRS 207A)	EA	4	6,200.00	24,800.00	5,800.00	23,200.00
10	260201	CLASS 2 AGGREGATE BASE	CY	450	61.00	27,450.00	36.00	16,200.00
11	390130	HOT MIX ASPHALT	TON	750	74.20	55,650.00	118.00	88,500.00
12	650014	18" REINFORCED CONCRETE PIPE	LF	86	215.00	18,490.00	112.00	9,632.00
13	650018	24" REINFORCED CONCRETE PIPE	LF	20	430.00	8,600.00	206.00	4,120.00
14	153103	COLD PLANE ASPHALT CONCRETE PAVEMENT	SQYD	2,355	3.95	9,302.25	4.00	9,420.00
15	800320	CHAIN LINK FENCE (TYPE CL-4)	LF	175	16.40	2,870.00	18.00	3,150.00
16	800360	CHAIN LINK FENCE (TYPE CL-6) (INCLUDING GATE)	LF	340	25.00	8,500.00	27.00	9,180.00
17	017110	MANHOLE (RCFC & WCDS MH 254)	EA	1	7,300.00	7,300.00	4,400.00	4,400.00
18	017003	CATCH BASIN (CURB INLET) (CRS 300)	EA	2	7,100.00	14,200.00	7,200.00	14,400.00
19	840515	THERMOPLASTIC PAVEMENT MARKING	SQFT	285	5.50	1,567.50	6.00	1,710.00
20	566011	ROADSIDE SIGN - ONE POST	EA	2	275.00	550.00	295.00	590.00
21	840656	PAINT TRAFFIC STRIPE (2-COAT)	LF	3,800	0.55	2,090.00	1.20	4,560.00
22	019901	DEMOBILIZATION	LS	1	10,000.00	10,000.00	10,000.00	10,000.00
23	394002	PLACE ASPHALT CONCRETE (MISCELLANEOUS AREA)	SQYD	200	17.40	3,480.00	36.00	7,200.00
24	010602	MISCELLANEOUS WORK (AS DIRECTED)	FA	1	25,000.00	25,000.00	25,000.00	25,000.00

**Roadway Engineering
Mira Loma, CA 91752**

**Ted Enterprises, Inc.
San Clemente, CA 92672**

Project Total Items 1-24						338,361.00		343,591.00
-------------------------------------	--	--	--	--	--	-------------------	--	-------------------

**Riverside County Transportation Department
Summary of Bids**

**PROJECT: Temescal Canyon Road and Dos Lagos Drive
Street Improvements Project
El Cerrito Area Adjacent to the City of Corona**

Advertised: January 29, 2013 (Agenda Item: 3.44)
Addenda: One (2/14/2013), Two (2/20/2013), Three (2/21/2013), Four (2/25/2013)
Bids Open: 2 pm Date: Wednesday, February 27, 2013

PROJECT No. C2-0154

BASE BID ITEM NO.	ITEM CODE	CONTRACT ITEM	UNITS	QUANTITY	10		11	
					BID UNIT PRICE	BID ESTIMATE	BID UNIT PRICE	BID ESTIMATE
1	066102	DUST ABATEMENT	LS	1	1,060.00	1,060.00	1,000.00	1,000.00
2	074020	WATER POLLUTION CONTROL	LS	1	10,000.00	10,000.00	2,500.00	2,500.00
3	120100	TRAFFIC CONTROL SYSTEM	LS	1	13,450.00	13,450.00	6,000.00	6,000.00
4	160101	CLEARING AND GRUBBING	LS	1	28,194.00	28,194.00	52,000.00	52,000.00
5	170101	DEVELOP WATER SUPPLY	LS	1	575.00	575.00	500.00	500.00
6	190101	ROADWAY EXCAVATION	CY	655	64.50	42,247.50	45.00	29,475.00
7	731521	MINOR CONCRETE (SIDEWALK) (INCLUDING 12" HIGH AND 6" WIDE CONCRETE CURB BEHIND SIDEWALK)	SQFT	5,000	7.62	38,100.00	4.00	20,000.00
8	017305	MINOR CONCRETE (CURB AND GUTTER) (CRS 201)	LF	500	32.85	16,425.00	19.00	9,500.00
9	017312	MINOR CONCRETE (COMERCIAL DRIVEWAY) (CRS 207A)	EA	4	7,365.00	29,460.00	5,000.00	20,000.00
10	260201	CLASS 2 AGGREGATE BASE	CY	450	24.00	10,800.00	55.00	24,750.00
11	390130	HOT MIX ASPHALT	TON	750	84.30	63,225.00	110.00	82,500.00
12	650014	18" REINFORCED CONCRETE PIPE	LF	86	74.52	6,408.72	190.00	16,340.00
13	650018	24" REINFORCED CONCRETE PIPE	LF	20	110.11	2,202.20	250.00	5,000.00
14	153103	COLD PLANE ASPHALT CONCRETE PAVEMENT	SQYD	2,355	4.00	9,420.00	4.00	9,420.00
15	800320	CHAIN LINK FENCE (TYPE CL-4)	LF	175	16.52	2,891.00	16.00	2,800.00
16	800360	CHAIN LINK FENCE (TYPE CL-6) (INCLUDING GATE)	LF	340	25.52	8,676.80	25.00	8,500.00
17	017110	MANHOLE (RCFC & WCDS MH 254)	EA	1	7,920.00	7,920.00	3,600.00	3,600.00
18	017003	CATCH BASIN (CURB INLET) (CRS 300)	EA	2	9,068.00	18,136.00	5,000.00	10,000.00
19	840515	THERMOPLASTIC PAVEMENT MARKING	SQFT	285	5.56	1,584.60	6.00	1,710.00
20	566011	ROADSIDE SIGN - ONE POST	EA	2	278.00	556.00	300.00	600.00
21	840656	PAINT TRAFFIC STRIPE (2-COAT)	LF	3,800	0.56	2,128.00	1.00	3,800.00
22	019901	DEMOBILIZATION	LS	1	10,000.00	10,000.00	10,000.00	10,000.00
23	394002	PLACE ASPHALT CONCRETE (MISCELLANEOUS AREA)	SQYD	200	36.00	7,200.00	70.00	14,000.00
24	010602	MISCELLANEOUS WORK (AS DIRECTED)	FA	1	25,000.00	25,000.00	25,000.00	25,000.00

Project Total Items 1-24						355,659.82		358,995.00
-------------------------------------	--	--	--	--	--	-------------------	--	-------------------

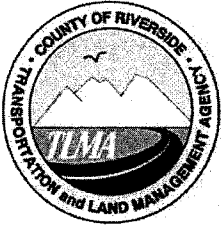

COUNTY OF RIVERSIDE TRANSPORTATION AND LAND MANAGEMENT AGENCY



Juan C. Perez, P.E., T.E.
Director of Transportation

Transportation Department

ADDENDUM NUMBER 1 Dated February 14, 2013

to the
Specifications and Contract Documents
for the construction of

Temescal Canyon Road and Dos Lagos Drive
Street Improvements Project
El Cerrito Area Adjacent to the City of Corona

Project No. C2-0154

Bids Due: **Wednesday, February 20, 2013; 2:00 PM**
14th Street Transportation Annex
3525 14th Street; Riverside, CA 92501
(951) 955-6780

This Addendum is issued pursuant to the Instructions to Bidders, Item No. 8, of the Contract Documents for the reference project. This Addendum is issued as a supplement to the specification and special provisions for the referenced project. The revisions to the specifications shall become a part of the Contract Documents, and each bidder shall acknowledge receipt thereof on the Contractor's Proposal. Bidders are directed to sign this addendum as acknowledged, and attach the signed addendum to the contractor's submitted proposal.

Note: During the advertisement period of this project, this document and attachments (if any) are available upon request at the office of the Transportation Department, and are available as a free download at the Transportation Department's website:

http://www.rctlma.org/trans/con_bid_advertisements.html

MODIFICATIONS / CLARIFICATIONS TO SPECIAL PROVISIONS:

Item 1: Revised Proposal
Refer to "Proposal" page B3. Proposal (page B3) is deleted and replaced with revised "Proposal" attached herewith as **Attachment "A"**. The following revisions have been made to the bid Proposal:

a. The following bid items descriptions have been revised:

- Item 7, MINOR CONCRETE (SIDEWALK) [INCLUDING 12" HIGH AND 6" WIDE CONCRETE CURB BEHIND SIDEWALK]

- Item 9, MINOR CONCRETE (COMMERCIAL DRIVEWAY)(CRS 207 A)
 - Item 16, CHAIN LINK FENCE (TYPE CL-6) (INCLUDING GATE)
- b. The quantities of following bid items have been revised:
- Item 9, MINOR CONCRETE (COMMERCIAL DRIVEWAY)(CRS 207 A)
 - Item 10, CLASS2 AGGREGATE BASE
 - Item 11, HOT MIX ASPHALT
 - Item 16, CHAIN LINK FENCE(TYPE CL-6) (INCLUDING GATE)
- c. The following bid items have been added:
- Item 23, PLACE ASPHALT CONCRETE (MISCELLANEOUS AREA)
 - Item 24, MISCELLANEOUS WORK (AS DIRECTED)

See Attachment "A", Revised Proposal

Item 2:

Clearing and Grubbing

Refer to section "Clearing and Grubbing" on page 64 of the Specification Book. The following Special Provisions are added and made part hereof:

Clearing and grubbing shall also include the removal and proper disposal of concrete inlet and any sawcutting tasks and proper removal of existing storm drain pipe to accommodate new manhole.

Full compensation for the removal and proper disposal of concrete inlet with and the sawcutting and removal of existing storm drain pipes to accommodate new manhole shall be paid for on a lump sum basis included in Clearing and Grubbing item for furnishing all labor, equipment, materials and tools, and incidentals at the locations shown on the plans.

Item 3:

Place Asphalt Concrete (Miscellaneous Area)

Refer to section "Place Asphalt Concrete (Miscellaneous Area)" on page 77 of the Special Provisions.

Delete the fourth paragraph of this section.

The following Special Provisions are added and made part hereof:

In areas where a commercial driveway will be constructed adjacent to paved parking lot, the Contractor shall sawcut and remove the existing asphalt concrete, base and subgrade. This area will accommodate the placement of 0.50' thick of asphalt concrete by 15' long, from the back of the commercial driveway approach, by the width of the commercial driveway approach (0.50' Depth X 15' Length X Width of Commercial Driveway) .

On Weirick Road, on locations where commercial driveway and concrete curb and gutter will be constructed, the Contractor shall sawcut and remove a 2' wide section from the existing asphalt, base and subgrade to depth of 2.05'. The Contractor shall place 0.55' asphalt concrete over 1.50' of Class 2 Aggregate Base for these areas.

The Class 2 Aggregate Base shall conform to the Special Provisions for "Aggregate Base".

These provisions shall conform to the special provisions under **Roadway Excavation** with the exception of the Method of Payment of the Roadway Excavation. The sawcutting and removal of the existing asphalt concrete, base and subgrade for Place Asphalt Concrete (Miscellaneous Area) will be paid under the Place Asphalt Concrete (Miscellaneous Area) item of work.

Additionally, the last paragraph (Method of Payment) of the "Place Asphalt Concrete (Miscellaneous Area)" special provisions is deleted and replaced with the following paragraph:

Method of Payment:

The contract unit price paid per square yard for Place Asphalt Concrete (Miscellaneous Area) shall include full compensation for furnishing all labor, materials (other than asphalt concrete), tools, and equipment and for doing all the work involved in placing and compacting asphalt concrete (miscellaneous areas), the sawcutting and removal of existing asphalt concrete, base and subgrade, recompaction of subgrade to 95% relative compaction and the requirements set in these special provisions and no additional compensation will be allowed therefor.

Item 4: Minor Concrete Sidewalk, Driveway Approach, Curbs, and Gutters
Refer to section "Minor Concrete Sidewalk, Driveway Approach, Curbs and Gutters" on page 78 of the Special Provisions.

Delete the third paragraph and replace it with the following paragraph:

Unless otherwise noted under these special provisions, the area behind and along the concrete improvements shall be filled and compacted with native or selective material and graded to match and provide a smooth transition from the edge of the new improvements to the satisfaction of the Engineer.

The following Special Provisions are added and made part hereof:

Contractor shall remove only the vegetation needed to construct these improvements.

Prior to removal of existing vegetation (trees, shrubs, bushes, and groundcover), the Contractor shall inventory all the existing vegetation (trees, shrubs, bushes, and ground cover) to be removed and replaced. The inventory shall be conducted with the Resident Engineer. Vegetation shall be replaced with the same size and species as the one that was removed and will be paid under various contract items of work involved and no additional compensation will be allowed therefor.

Contractor shall replace any vegetation (trees, shrubs, bushes and groundcover) damaged during the placement of these improvements. Vegetation shall be replaced with the same size and species as the one that was damaged at the Contractor's expense.

Contractor shall relocate, modify, and repair all the existing irrigation lines affected by the construction of this project. Included in the relocation, modification and repair of the existing irrigation is the furnishing of materials and accessories needed to make the existing irrigation system work properly with the replaced vegetation (trees, shrubs, bushes, and ground cover). Existing irrigation system may need to be relocated and modified more than once depending on the staging of this project and will be paid under various contract items of work involved and no additional compensation will be allowed therefor. The modifications in the existing irrigation line shall be performed to the satisfaction of the County Resident Engineer.

If any of the irrigation hand holes are damaged, Contractor shall replace the damage hand holes. Full compensation for furnishing all labor, materials, tools, equipment, and incidentals, and for doing all the work involved for replacing damaged hand holes shall be paid under various contract items of work involved and no additional compensation will be allowed therefor.

Delete the second paragraph under Method of Payment, and replace it with the following paragraph:

Method of Payment:

The contract unit bid prices paid per square foot for Minor Concrete (Sidewalk) [Including 12" High X 6" Wide Concrete Curb]; per linear foot for Minor Concrete (Curb and Gutter); and per each for Minor Concrete (Commercial Driveway Approach) shall include full compensation for furnishing all labor, equipment, materials, tools, and incidentals, the sawcutting and removal of existing asphalt concrete, base and subgrade and for doing all the work involved in the construction and complete in place including the furnishing and placing of expansion joints and these special provisions and no additional compensation will be allowed therefor.

Item 5: Chain Link Fence

Refer to section "Chain Link Fence" on page 84 of the Specification Book. Delete and replace this section with the following:

CHAIN LINK FENCE AND GATE:

Chain link fence shall be Type CL-4 and CL-6 and shall conform to the provisions of Section 80, and Section 80-4 of the Standard Specifications, plans, and as directed by the Engineer.

The Fence and Gate shall conform to the APWA Standard Plans 600-3.

Method of Payment:

The contract unit bid price paid per linear foot for "Chain Link Fence (CL-4)" and Chain Link Fence (Type CL-6) (Including Gate) shall include full compensation for

furnishing all labor, equipment, materials and tools, and incidentals, and for doing all the work involved including the furnishing and installation of the 36' Double Drive Gate, any removal of post and foundation, excavation and backfill with concrete and no additional compensation will be allowed therefor.

Item 6: Obtain Encroachment Permit

The following Special Provisions are added and made part hereof:

It shall be the responsibility of the Contractor to obtain an encroachment permit for any work within the Right-Of-Way of the City of Corona.

There is no construction work shown on the plans within the Jurisdiction of the City of Corona; however, it is anticipated that Contractor may have to obtain an Encroachment permit for Traffic Control and/or striping purpose.

Method of Payment:

Full compensation for all costs associated with "Obtain Encroachment Permit" shall be considered as included in the various items of work involved, and no additional compensation will be allowed therefor.

Item 7: Miscellaneous Work (As Directed)

The following Special Provisions are added and made part hereof:

Miscellaneous Work (As Directed) shall consist of necessary work that is not included in other contract bid items, as determined by the Engineer. Miscellaneous work shall be performed as directed by the Engineer and in accordance with the applicable standards and specifications.

Method of Payment:

Payment for implementing miscellaneous work (as directed) will be paid for on a force account basis, in accordance with Section 9-1.03 of the Standard Specifications, up to the fixed bid price, for the work performed.

MODIFICATIONS / CLARIFICATIONS TO PLANS:

Item 8: Construction Notes

Refer to Construction notes on the plans, delete and replace following Construction Notes as noted below:

Construction Note 10:
Install 4' Chain Link Fence per APWA Standard Plans 300-6.

Construction Note 18:
Install 6' Chain Link Fence and Gate per APWA Standard Plans 300-6.

See Attachment "B", Standard Plan 600-3

Addendum No. 1
Temescal Canyon Road and Dos Lagos Drive
Street Improvements Project, El Cerrito Area Adjacent to the City of Corona
Project No. C2-0154
February 14, 2013
Page 6 of 6

This addendum has been prepared under the direction of the following registered Civil Engineer(s):

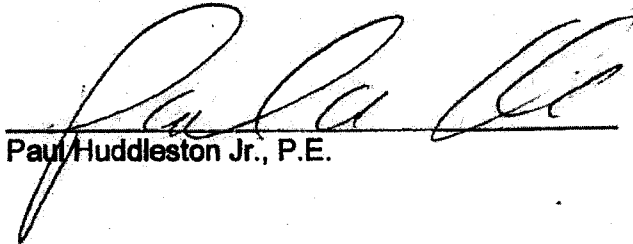

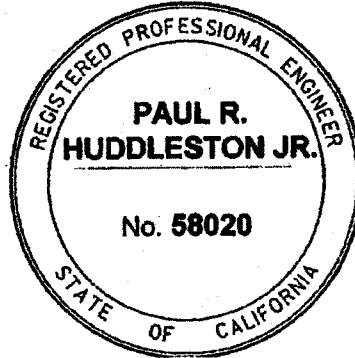
Paul Huddleston Jr., P.E.



Recommended by:

Cindi Wachi, PE
County Project Manager

Concurrence:

 2/14/13
Khalid Nasim, PE
Engineering Division Manager

Acknowledged: _____ Date: _____
(Contractor)

JRJ:jjr:rr:sb

TEMESCAL CANYON ROAD AND DOS LAGOS DRIVE
 STREET IMPROVEMENTS PROJECT
 EL CERRITO AREA ADJACENT TO THE CITY OF CORONA
 PROJECT No. C2-0154

PROPOSAL (REVISED)

ITEM No.	ITEM CODE	ITEM	UNIT	ESTIMATED QUANTITY	ITEM PRICE (IN FIGURES)	TOTAL (IN FIGURES)
1	066102	DUST ABATEMENT	LS	1		
2	074020	WATER POLLUTION CONTROL	LS	1		
3	120100	TRAFFIC CONTROL SYSTEM	LS	1		
4	160101	CLEARING AND GRUBBING	LS	1		
5	170101	DEVELOP WATER SUPPLY	LS	1		
6	190101	ROADWAY EXCAVATION	CY	655		
7	731521	MINOR CONCRETE (SIDEWALK) (INCLUDING 12" HIGH AND 6" WIDE CONCRETE CURB BEHIND SIDEWALK)	SQFT	5,000		
8	017305	MINOR CONCRETE (CURB AND GUTTER) (CRS 201)	LF	665		
9	017312	MINOR CONCRETE (COMMERCIAL DRIVEWAY) (CRS 207A)	EA	4		
10	260201	CLASS 2 AGGREGATE BASE	CY	375		
11	390130	HOT MIX ASPHALT	TON	300		
12	650014	18" REINFORCED CONCRETE PIPE	LF	86		
13	650018	24" REINFORCED CONCRETE PIPE	LF	20		
14	153103	COLD PLANE ASPHALT CONCRETE PAVEMENT	SQYD	2,275		
15	800320	CHAIN LINK FENCE (TYPE CL-4)	LF	175		
16	800360	CHAIN LINK FENCE (TYPE CL-6) (INCLUDING GATE)	LF	340		
17	017110	MANHOLE (RCFC & WCDS MH 254)	EA	1		
18	017003	CATCH BASIN (CURB INLET) (CRS 300)	EA	2		
19	840515	THERMOPLASTIC PAVEMENT MARKING	SQFT	285		
20	566011	ROADSIDE SIGN - ONE POST	EA	2		
21	840656	PAINT TRAFFIC STRIPE (2-COAT)	LF	3,800		
22	019901	DEMOBILIZATION	LS	1	10,000.00	10,000.00
23	394002	PLACE ASPHALT CONCRETE (MISCELLANEOUS AREA)	SQYD	200		
24	010602	MISCELLANEOUS WORK (AS DIRECTED)	FA	1	25,000.00	25,000.00

Addendum No. 1, Page 7 of 10

PROJECT TOTAL: _____ \$ _____
 ITEMS 1-24 "WORDS"

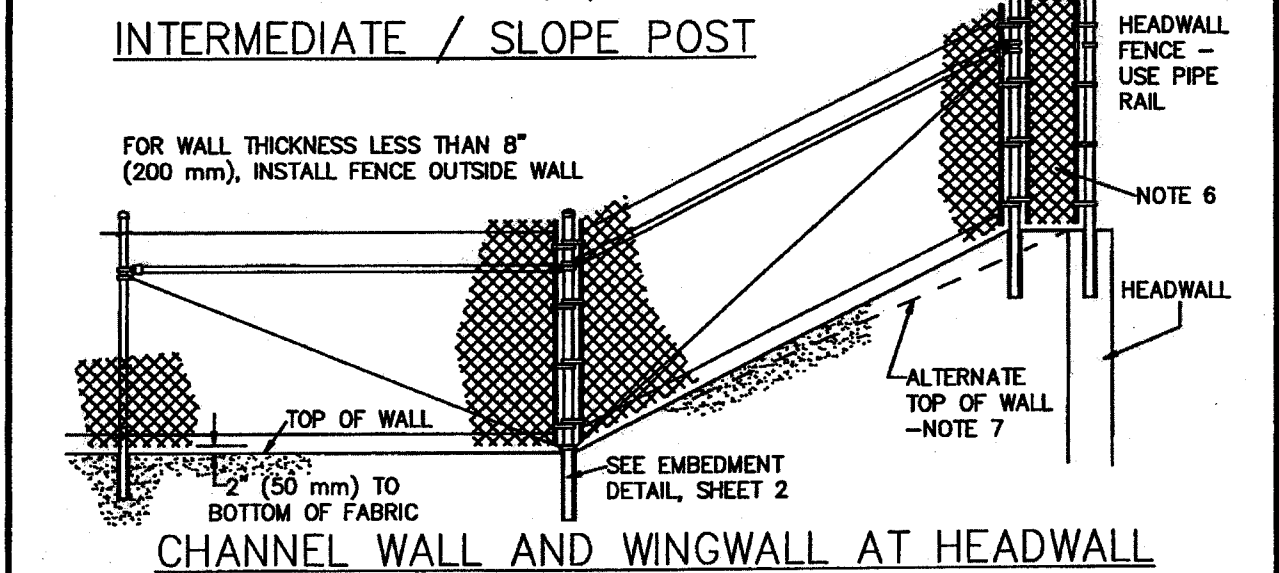
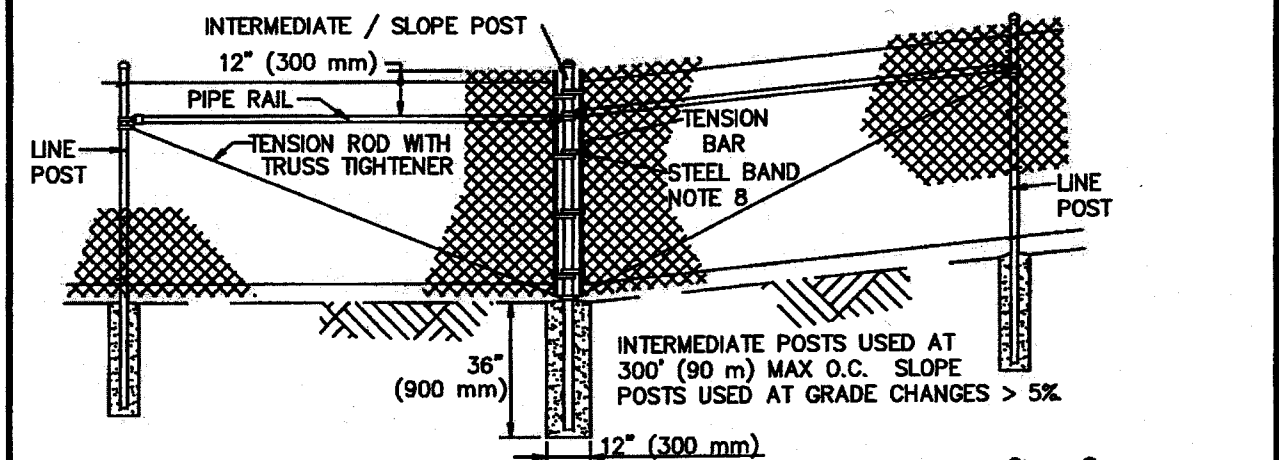
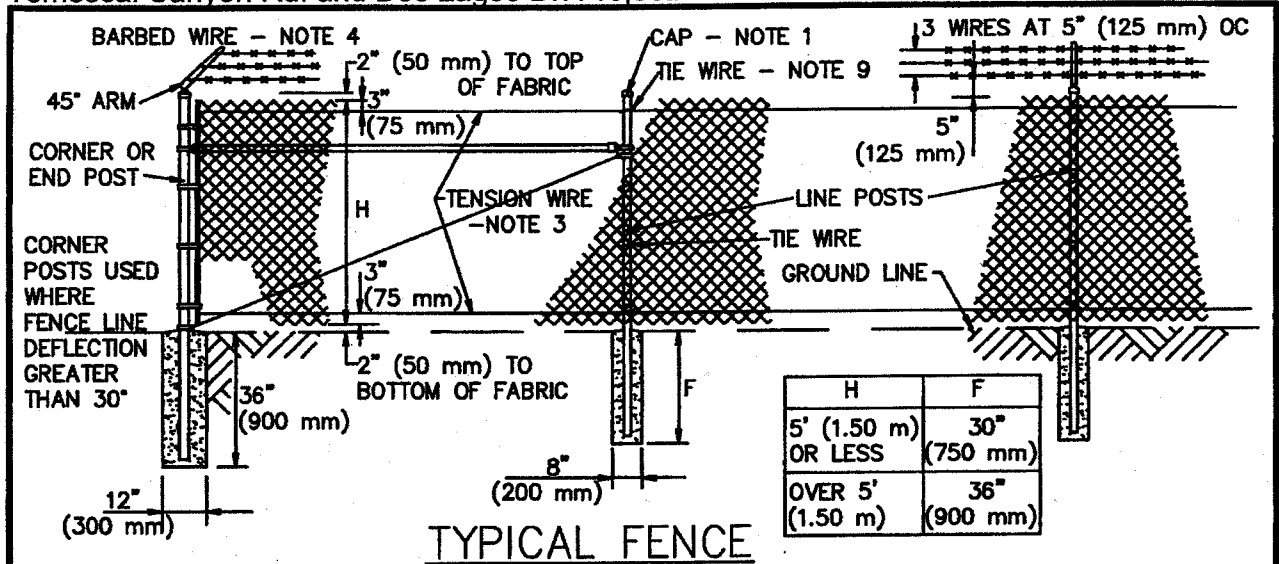

STANDARD PLANS FOR PUBLIC WORKS CONSTRUCTION

PROMULGATED BY THE PUBLIC WORKS STANDARDS INC. GREENBOOK COMMITTEE 1984 REV. 1996, 2005	CHAIN LINK FENCE AND GATES	STANDARD PLAN 600-3 SHEET 1 OF 3
USE WITH STANDARD SPECIFICATIONS FOR PUBLIC WORKS CONSTRUCTION		

Addendum No. 1, Page 8 of 10

BARBED WIRE - NOTE 4

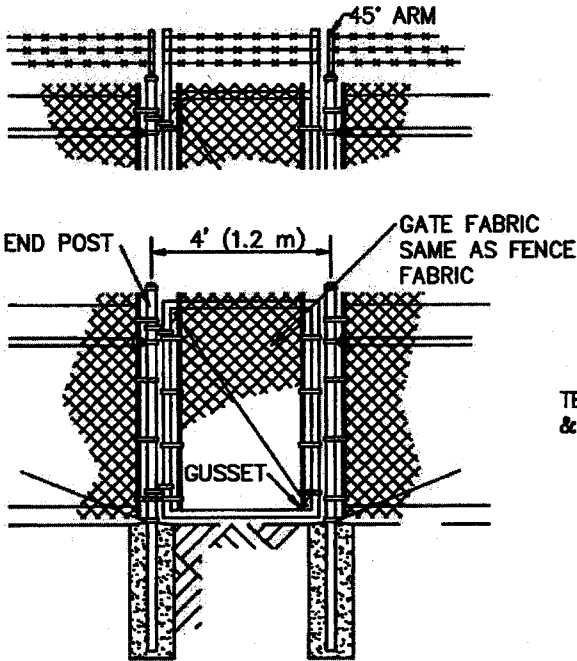

WALK GATE

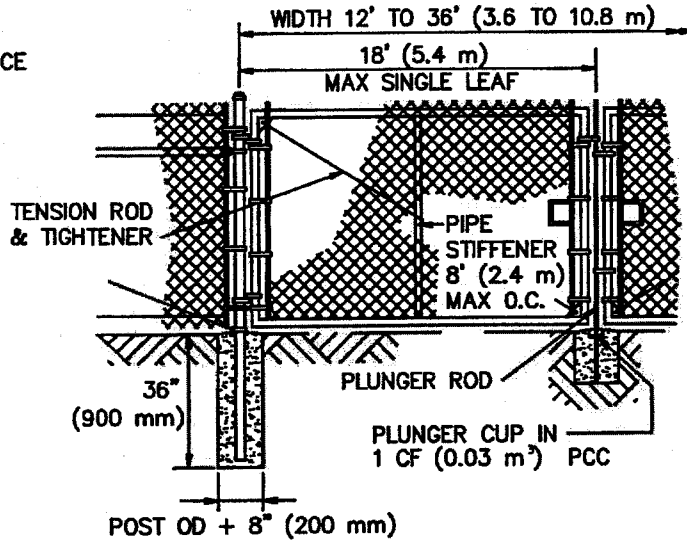

DRIVE GATE

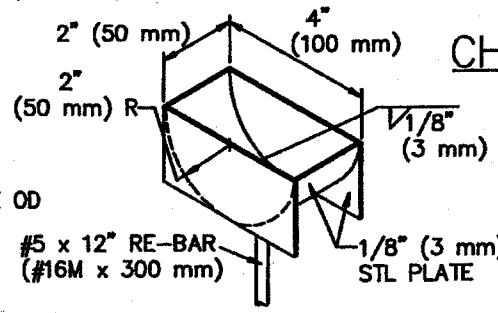
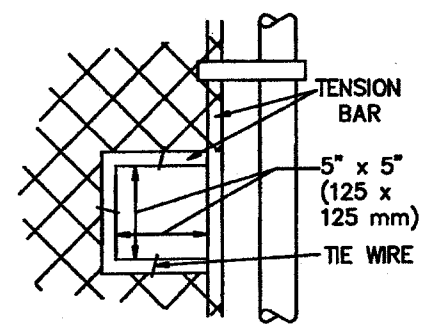
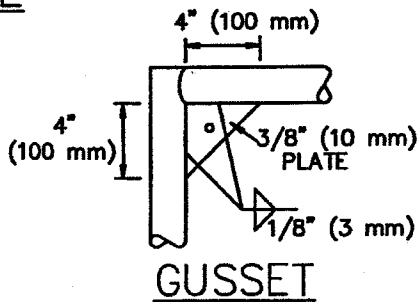
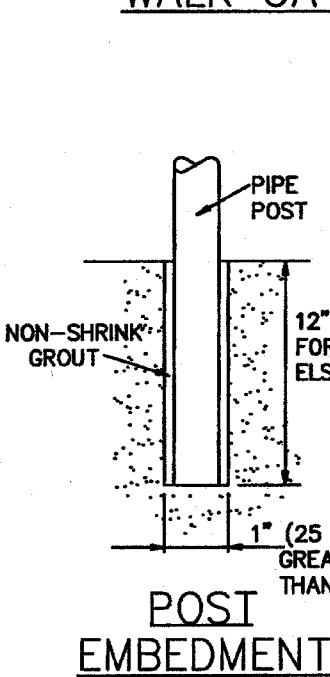

Addendum No. 1, Page 9 of 10

STANDARD PLANS FOR PUBLIC WORKS CONSTRUCTION	STANDARD PLAN
CHAIN LINK FENCE AND GATES	600-3
	SHEET 2 OF 3

NOTES:

1. SECURE DRIVE-FIT GALVANIZED CAP TO POST WITH 1/4" (6 mm) ROUND-HEAD RIVET.
2. H DENOTES FABRIC WIDTH AND NOMINAL FENCE HEIGHT. $H = 5'$ (1.5 m) UNLESS OTHERWISE NOTED.
3. IF FENCE WITH TOP RAIL IS SPECIFIED, DELETE STEEL TENSION WIRE AT TOP, AND PIPE RAILS AT INTERMEDIATE, SLOPE, END AND CORNER POSTS. EXTEND TENSION ROD TO TOP RAIL.
4. BARBED WIRE SHALL BE USED ONLY WHEN SPECIFIED.
5. POST SPACING IS MAXIMUM 10' (3.0 m).
6. FILL CLEAR OPENINGS GREATER THAN 3" (75 mm) WITH FABRIC. FOR OPENINGS LESS THAN 18" (450 mm), TIE FABRIC TO POSTS.
7. USE ONE POST FOR COMBINED SLOPE AND CORNER POST IF TOP OF CHANNEL WALL IS CONSTRUCTED AS SHOWN FOR "ALTERNATE".
8. STEEL BANDS AT TENSION BARS SHALL BE 1/8" x 1" (3 x 25 mm), MINIMUM, SPACED AT MAXIMUM 16" (400 mm).
9. SECURE TENSION WIRES TO EACH LINE POST WITH TIE WIRES.

Addendum No. 1, Page 10 of 10

STANDARD PLANS FOR PUBLIC WORKS CONSTRUCTION	STANDARD PLAN
CHAIN LINK FENCE AND GATES	600-3 SHEET 3 OF 3

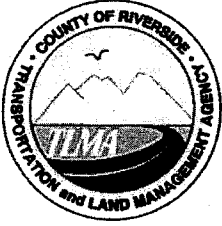

**COUNTY OF RIVERSIDE
TRANSPORTATION AND
LAND MANAGEMENT AGENCY**



Juan C. Perez, P.E., T.E.
Director of Transportation

Transportation Department

ADDENDUM NUMBER 2
Dated February 20, 2013

to the
**Specifications and Contract Documents
for the construction of
Temescal Canyon Road and Dos Lagos Drive
Street Improvements Project
El Cerrito Area Adjacent to the City of Corona
Project No. C2-0154**

Bids Due: (REVISED)
Wednesday, February 27, 2013; 2:00 PM
14th Street Transportation Annex
3525 14th Street; Riverside, CA 92501
(951) 955-6780

This Addendum is issued pursuant to the Instructions to Bidders, Item No. 8, of the Contract Documents for the reference project. This Addendum is issued as a supplement to the specification and special provisions for the referenced project. The revisions to the specifications shall become a part of the Contract Documents, and each bidder shall acknowledge receipt thereof on the Contractor's Proposal. Bidders are directed to sign this addendum as acknowledged, and attach the signed addendum to the contractor's submitted proposal.

Note: During the advertisement period of this project, this document and attachments (if any) are available upon request at the office of the Transportation Department, and are available as a free download at the Transportation Department's website:

http://www.rctlma.org/trans/con_bid_advertisements.html

MODIFICATIONS / CLARIFICATIONS TO SPECIAL PROVISIONS:

Item 1: The new designated date and time for the receipt and opening of bids is revised as follows:

Wednesday, February 27, 2013; 2:00 PM
14th Street Transportation Annex
3525 14th Street; Riverside, CA 92501
(951) 955-6780

Recommended by

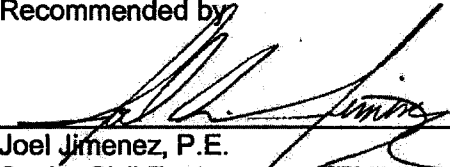

Joel Jimenez, P.E.
Senior Civil Engineer

Acknowledged: _____ Date: _____
(Contractor)
JRJ:jjr:r

Addendum No. 2, Page 1 of 1

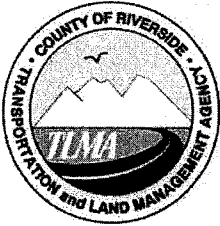

COUNTY OF RIVERSIDE TRANSPORTATION AND LAND MANAGEMENT AGENCY

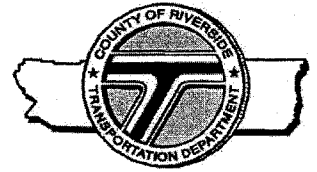

Juan C. Perez, P.E., T.E.
Director of Transportation

Transportation Department

ADDENDUM NUMBER 3
Dated February 21, 2013

to the
Specifications and Contract Documents
for the construction of

Temescal Canyon Road and Dos Lagos Drive
Street Improvements Project
El Cerrito Area Adjacent to the City of Corona

Project No. C2-0154

Bids Due: **Wednesday, February 27, 2013; 2:00 PM**
14th Street Transportation Annex
3525 14th Street; Riverside, CA 92501
(951) 955-6780

This Addendum is issued pursuant to the Instructions to Bidders, Item No. 8, of the Contract Documents for the reference project. This Addendum is issued as a supplement to the specification and special provisions for the referenced project. The revisions to the specifications shall become a part of the Contract Documents, and each bidder shall acknowledge receipt thereof on the Contractor's Proposal. Bidders are directed to sign this addendum as acknowledged, and attach the signed addendum to the contractor's submitted proposal.

Note: During the advertisement period of this project, this document and attachments (if any) are available upon request at the office of the Transportation Department, and are available as a free download at the Transportation Department's website:

http://www.rctlma.org/trans/con_bid_advertisements.html

MODIFICATIONS / CLARIFICATIONS TO SPECIAL PROVISIONS:

Item 1: Revised Proposal
Refer to Addendum No. 1, Attachment A, "Revised Proposal". Revised proposal (Attachment "A" of Addendum No. 1) is deleted and replaced with revised "Proposal" attached herewith as **Attachment "A"**. The following revisions have been made to the bid Proposal:

- a. The quantities of the following bid items have been revised:
 - Item 10, CLASS2 AGGREGATE BASE
 - Item 11, HOT MIX ASPHALT, and

- Item 14, COLD PLANE ASPHALT CONCRETE PAVEMENT

See Attachment "A", Revised Proposal

- Item 2: Clarification – Removal of Asphalt**
Refer to section "Roadway Excavation" on page 66 of the Special Provisions.

Full compensation for the removal and proper disposal of asphalt concrete necessary to accommodate slopes as shown on the plans and as specified in the special provisions shall be considered as included in the Roadway Excavation item of work for furnishing all labor, equipment, materials and tools, and incidentals.

- Item 3: Minor Concrete Sidewalk, Driveway Approach, Curbs, and Gutters**
Refer to Addendum No. 1, Item No. 4, "Minor Concrete Sidewalk, Driveway Approach, Curbs and Gutters". The Method of Payment section at the end of this item is deleted and replaced with the following paragraph:

Method of Payment:

The contract unit bid prices paid per square foot for Minor Concrete (Sidewalk) [Including 12" High X 6" Wide Concrete Curb]; per linear foot for Minor Concrete (Curb and Gutter); and per each for Minor Concrete (Commercial Driveway Approach) shall include full compensation for furnishing all labor, equipment, materials, tools, and incidentals, including the sawcutting and removal of existing asphalt concrete, base and subgrade and for doing all the work involved in the construction and complete in place, including the furnishing and placing of expansion joints, and for doing all the work involved as specified in the Standard Specifications and these Special Provisions and as directed by the Resident Engineer and no additional compensation will be allowed therefor.

- Item 4: Clarification – Curb and Gutter**

Curb and gutter within the limits of commercial driveways shall be considered included as part of the Driveway Approaches. Full compensation for curb and gutter within the limits of commercial driveways shall be considered as included in the contract price paid per each for Minor Concrete (Commercial Driveway) and shall include full compensation for furnishing all labor, equipment, materials and tools, and incidentals, and for doing all the work involved.

MODIFICATIONS / CLARIFICATIONS TO PLANS:

Item 5: Clarification –Driveway Locations

Four driveways will be constructed, their location are as follows:

- Temescal Canyon Road:
 1. at Sta 74+92
 2. at Sta 78+31

- Dos Lagos Drive (Weirick Road):
 3. at Sta 12+00 approximately (see note on plans 'RECONSTRUCT PORTION OF DRIVEWAY')
 4. at Sta 14+25 approximately (see construction note 11 on plans)

Addendum No. 3
Temescal Canyon Road and Dos Lagos Drive
Street Improvements Project, El Cerrito Area Adjacent to the City of Corona
Project No. C2-0154
February 21, 2013
Page 4 of 4

This addendum has been prepared under the direction of the following registered Civil Engineer(s):

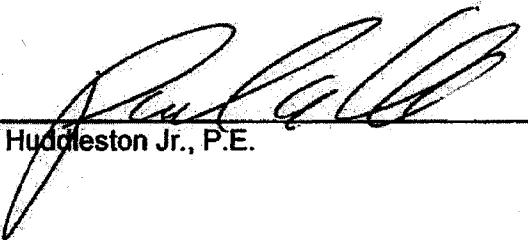

Paul Huddleston Jr., P.E.



Recommended by:



Cindi Wachi, PE
County Project Manager

Concurrence:

Signature in file

Khalid Nasim, PE
Engineering Division Manager

Acknowledged: _____ **Date:** _____
(Contractor)

JRJ:jj:rr

**TEMESCAL CANYON ROAD AND DOS LAGOS DRIVE
STREET IMPROVEMENTS PROJECT
EL CERRITO AREA ADJACENT TO THE CITY OF CORONA
PROJECT No. C2-0154**

PROPOSAL (REVISED)

ITEM No.	ITEM CODE	ITEM	UNIT	ESTIMATED QUANTITY	ITEM PRICE (IN FIGURES)	TOTAL (IN FIGURES)
1	066102	DUST ABATEMENT	LS	1		
2	074020	WATER POLLUTION CONTROL	LS	1		
3	120100	TRAFFIC CONTROL SYSTEM	LS	1		
4	160101	CLEARING AND GRUBBING	LS	1		
5	170101	DEVELOP WATER SUPPLY	LS	1		
6	190101	ROADWAY EXCAVATION	CY	655		
7	731521	MINOR CONCRETE (SIDEWALK) (INCLUDING 12" HIGH AND 6" WIDE CONCRETE CURB BEHIND SIDEWALK)	SQFT	5,000		
8	017305	MINOR CONCRETE (CURB AND GUTTER) (CRS 201)	LF	665		
9	017312	MINOR CONCRETE (COMMERCIAL DRIVEWAY) (CRS 207A)	EA	4		
10	260201	CLASS 2 AGGREGATE BASE	CY	450		
11	390130	HOT MIX ASPHALT	TON	750		
12	650014	18" REINFORCED CONCRETE PIPE	LF	86		
13	650018	24" REINFORCED CONCRETE PIPE	LF	20		
14	153103	COLD PLANE ASPHALT CONCRETE PAVEMENT	SQYD	2,355		
15	800320	CHAIN LINK FENCE (TYPE CL-4)	LF	175		
16	800360	CHAIN LINK FENCE (TYPE CL-6) (INCLUDING GATE)	LF	340		
17	017110	MANHOLE (RCFC & WCDS MH 254)	EA	1		
18	017003	CATCH BASIN (CURB INLET) (CRS 300)	EA	2		
19	840515	THERMOPLASTIC PAVEMENT MARKING	SQFT	285		
20	566011	ROADSIDE SIGN - ONE POST	EA	2		
21	840656	PAINT TRAFFIC STRIPE (2-COAT)	LF	3,800		
22	019901	DEMOBILIZATION	LS	1	10,000.00	10,000.00
23	394002	PLACE ASPHALT CONCRETE (MISCELLANEOUS AREA)	SQYD	200		
24	010602	MISCELLANEOUS WORK (AS DIRECTED)	FA	1	25,000.00	25,000.00

Addendum No. 3, Page 5 of 5

PROJECT TOTAL: _____ \$ _____
ITEMS 1-24 "WORDS"

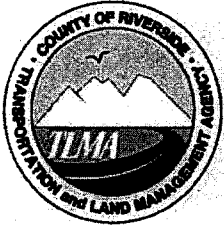

COUNTY OF RIVERSIDE TRANSPORTATION AND LAND MANAGEMENT AGENCY



ADDENDUM NUMBER 4

Dated February 25, 2013

to the

Specifications and Contract Documents
for the construction of

Temescal Canyon Road and Dos Lagos Drive
Street Improvements Project

El Cerrito Area Adjacent to the City of Corona
Project No. C2-0154

Bids Due:

Wednesday, February 27, 2013; 2:00 PM

14th Street Transportation Annex

3525 14th Street, Riverside, CA 92501

(951) 955-6780

This Addendum is issued pursuant to the Instructions to Bidders, Item No. 8, of the Contract Documents for the reference project. This Addendum is issued as a supplement to the specification and special provisions for the referenced project. The revisions to the specifications shall become a part of the Contract Documents, and each bidder shall acknowledge receipt thereof on the Contractor's Proposal. Bidders are directed to sign this addendum as acknowledged, and attach the signed addendum to the contractor's submitted proposal.

Note: During the advertisement period of this project, this document and attachments (if any) are available upon request at the office of the Transportation Department, and are available as a free download at the Transportation Department's website:

http://www.rctlma.org/trans/con_bid_advertisements.html

Item 1: Estimated Quantity Revision. Refer to Addendum No. 3, Attachment "A", Item 8 on revised bid proposal and make correction to the estimated quantity. Bidders are instructed to strikethrough and revise the estimated quantity for the listed bid item, and to submit a bid for the revised quantity of work. In the event that a bidding contractor fails to adjust the quantity as directed by this addendum, the subtotal bid price for this item will be corrected by multiplying the submitted unit bid price by the revised estimated quantity.

Item No.	Item Code	Item	Unit	Estimated Quantity
8	017305	MINOR CONCRETE (CURB AND GUTTER) (CRS 201)	LF	500

Prepared by:

Joel Jimenez, PE; Senior Civil Engineer, Contracts/Bidding Unit

Acknowledged: _____

Date: _____

(Contractor)

JRJ:rr

CONTRACTOR'S PROPOSAL

TO: COUNTY OF RIVERSIDE

DATE: February 27, 2013

hereafter called "County":

BIDDER: Mamco, Inc. dba Alabbasi

(hereafter called "Contractor")

THE UNDERSIGNED, Contractor, having carefully examined the site and the Contract Documents for the construction of Temescal Canyon Road and Dos Lagos Drive, Street Improvements Project, El Cerrito Area Adjacent to the City of Corona, Project No. C2-0154 hereby proposes to construct the work in accordance with the Contract Documents, including Addenda Nos. 1-4 for the amount stated in this Proposal.

By submitting this Proposal, Contractor agrees with County:

1. That unless withdrawn in person by Contractor or some not by telephone or telegram before the time specified opening of bids, this Proposal constitutes an irrevocable
2. County has the right to reject any or all Proposals and to
3. To execute the Agreement and deliver the Faithful Insurance Certificate with endorsements, which comply with the Instructions to Bidders and General Conditions, within the time specified in the Notice of Acceptance of Proposal and Intent to Award
4. That the contract shall be awarded upon a resolution of the governing body of County; and that execution of the Contract Documents shall constitute a written memorial thereof.
5. To submit to County such information as County may require to determine whether a particular Proposal is the lowest responsible bid submitted.

Clerk of the Board

6. That the accompanying certified or cashier's check or Bid Bond is in an amount not less than 10% of the total bid submitted and constitutes a guarantee that if awarded the contract, Contractor will execute the Agreement and deliver the required bonds within ten (10) days after notice of award. If Contractor fails to execute and deliver said documents, the check or bond is to be charged with the costs of the resultant damages to County, including but not limited to publication costs, the difference in money between the amount bid and the amount in excess of the bid which it costs County to do or cause to be done the work involved, lease and rental costs, additional salaries and overhead, increased interest and costs of funding the project, attorney expense, additional engineering and architectural expense and cost of maintaining or constructing alternate facilities occasioned by the failure to execute and deliver said documents.
7. By signing this proposal the Contractor certifies that the representations made therein are made under penalty of perjury.

**TEMESCAL CANYON ROAD AND DOS LAGOS DRIVE
STREET IMPROVEMENTS PROJECT
EL CERRITO AREA ADJACENT TO THE CITY OF CORONA
PROJECT No. C2-0154**

PROPOSAL (REVISED)

ITEM No.	ITEM CODE	ITEM	UNIT	ESTIMATED QUANTITY	ITEM PRICE (IN FIGURES)	TOTAL (IN FIGURES)
1	066102	DUST ABATEMENT	LS	1	5,949.75	5,949.75
2	074020	WATER POLLUTION CONTROL	LS	1	4,300	4,300
3	120100	TRAFFIC CONTROL SYSTEM	LS	1	18,100	18,100
4	160101	CLEARING AND GRUBBING	LS	1	18,500	18,500
5	170101	DEVELOP WATER SUPPLY	LS	1	540	540
6	190101	ROADWAY EXCAVATION	CY	655	16	10,480
7	731521	MINOR CONCRETE (SIDEWALK) (INCLUDING 12" HIGH AND 6" WIDE CONCRETE CURB BEHIND SIDEWALK)	SQFT	5,000	3.90	19,500
8	017305	MINOR CONCRETE (CURB AND GUTTER) (CRS 201)	LF	665 ⁵⁰⁰	16.50	8,250
9	017312	MINOR CONCRETE (COMMERCIAL DRIVEWAY) (CRS 207A)	EA	4	5,900	23,600
10	260201	CLASS 2 AGGREGATE BASE	CY	450	34	15,300
11	390130	HOT MIX ASPHALT	TON	750	78	58,500
12	650014	18" REINFORCED CONCRETE PIPE	LF	86	80	6,880
13	650018	24" REINFORCED CONCRETE PIPE	LF	20	110	2,200
14	153103	COLD PLANE ASPHALT CONCRETE PAVEMENT	SQYD	2,355	3	7,065
15	800320	CHAIN LINK FENCE (TYPE CL-4)	LF	175	14	2,450
16	800360	CHAIN LINK FENCE (TYPE CL-6) (INCLUDING GATE)	LF	340	24	8,160
17	017110	MANHOLE (RCFC & WCDS MH 254)	EA	1	4,375	4,375
18	017003	CATCH BASIN (CURB INLET) (CRS 300)	EA	2	4,727 ^{4,727}	9,454
19	840515	THERMOPLASTIC PAVEMENT MARKING	SQFT	285	5.25	1,496.25
20	566011	ROADSIDE SIGN - ONE POST	EA	2	262	524
21	840656	PAINT TRAFFIC STRIPE (2-COAT)	LF	3,800	.52	1,976
22	019901	DEMOBILIZATION	LS	1	10,000.00	10,000.00
23	394002	PLACE ASPHALT CONCRETE (MISCELLANEOUS AREA)	SQYD	200	32	6,400
24	010602	MISCELLANEOUS WORK (AS DIRECTED)	FA	1	25,000.00	25,000.00

PROJECT TOTAL:
ITEMS 1-24

two hundred sixty-nine thousand dollars

"WORDS"

\$269,000.00

Item Price #18 @ 4,727

BIDDER DATA:

Name of Bidder Mamco, Inc. dba Alabbasi

Type of Organization Corporation

Person(s) Authorized to Sign for Bidder Marwan Alabbasi, Elizabeth Alabbasi,

Rumzi Alabbasi

Address 16810 Van Buren Blvd. Suite 200 Riverside, CA 92504

Phone 951-776-9300

Contractor's License 883649- A

Type & Number

Expiration Date 09/30/2014

8. **DESIGNATION OF SUBCONTRACTORS:** Contractor submits the following complete list of each subcontractor who will perform work or labor or render service in or about the construction in an amount in excess of 1/2 of 1% of the total bid.

<u>ITEM</u>	<u>SUBCONTRACTOR</u>	<u>ADDRESS</u>	<u>LICENSE NO.</u>
11, 14, Portion of 23	All American Asphalt	400 E. Sixth St Corona, CA 92878	267073
RA 19 19-21	DC Traffic Specialist	638 W Soderin Ave Orange, CA 92865	877686

Percent of work to be performed by sub-contractors: 20 %
(Note: 50% of the work required to be performed by general contractor)

IN WITNESS WHEREOF Contractor executed this Proposal as of the date set forth on Page 1 of this proposal.

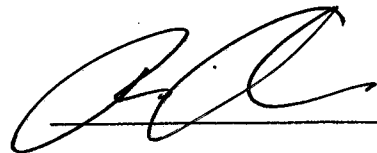

Rumzi Alabbasi

TITLE Vice President

"Contractor"

Non-Collusion Declaration

To be executed by bidder and submitted with bid. (Public Contract Code Section 7106)

The undersigned declares:

I am the Vice President (Title) of Mamco, Inc. dba Alabbasi (Company),
the party making the foregoing bid.

The bid is not made in the interest of, or on behalf of, any undisclosed person, partnership, company, association, organization, or corporation. The bid is genuine and not collusive or sham. The bidder has not directly or indirectly induced or solicited any other bidder to put in a false or sham bid. The bidder has not directly or indirectly colluded, conspired, connived, or agreed with any bidder or anyone else to put in a sham bid, or that anyone shall refrain from bidding. The bidder has not in any manner, directly or indirectly, sought by agreement, communication, or conference with anyone to fix the bid price of the bidder or any other bidder, or to fix any overhead, profit, or cost element of the bid price, or of that of any other bidder.

All statements contained in the bid are true. The bidder has not, directly or indirectly, submitted his or her bid price of any breakdown thereof, or the contents thereof, or divulged information or data relative thereto, to any corporation, partnership, company, association, organization, bid depository, or to any member or agent thereof to effectuate a collusive or sham bid, and has not paid, and will not pay, any person or entity for such purpose.

Any person executing this declaration on behalf of a bidder that is a corporation, partnership, joint venture, limited liability company, limited liability partnership, or any other entity, hereby represents that he or she has full power to execute, and does execute, this declaration on behalf of the bidder.

I declare under penalty of perjury under the laws of the State of California that the foregoing is true and correct and that this declaration is executed on

February (Month) 27th (Day) of 2013 (Year),

at Riverside (City), California.

Signature of Declarant:  _____

Printed name of Declarant: Rumzi Alabbasi

Name of Bidder (Company): Mamco, Inc. dba Alabbasi

Title or Office: Vice President

Note: Notarization of signature required.

Check box if attachment is included.

CALIFORNIA ALL-PURPOSE CERTIFICATE OF ACKNOWLEDGMENT

State of California

County of Riverside

On 2/27/13 before me, Rami M. Alabbasi, Notary Public
(Here insert name and title of the officer)

personally appeared Rumzi Alabbasi

who proved to me on the basis of satisfactory evidence to be the person(s) whose name(s) is are subscribed to the within instrument and acknowledged to me that he/she/they executed the same in his/her/their authorized capacity(ies), and that by his/her/their signature(s) on the instrument the person(s), or the entity upon behalf of which the person(s) acted, executed the instrument.

I certify under PENALTY OF PERJURY under the laws of the State of California that the foregoing paragraph is true and correct.

WITNESS my hand and official seal.

[Signature]
 Signature of Notary Public

(Notary Seal)

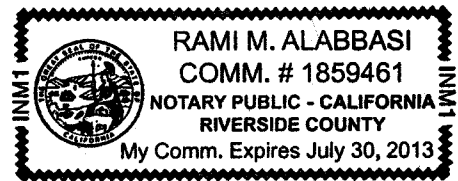

ADDITIONAL OPTIONAL INFORMATION

DESCRIPTION OF THE ATTACHED DOCUMENT

 (Title or description of attached document)

 (Title or description of attached document continued)

Number of Pages _____ Document Date _____

 (Additional information)

CAPACITY CLAIMED BY THE SIGNER

- Individual (s)
- Corporate Officer

 (Title)

- Partner(s)
- Attorney-in-Fact
- Trustee(s)
- Other _____

INSTRUCTIONS FOR COMPLETING THIS FORM

Any acknowledgment completed in California must contain verbiage exactly as appears above in the notary section or a separate acknowledgment form must be properly completed and attached to that document. The only exception is if a document is to be recorded outside of California. In such instances, any alternative acknowledgment verbiage as may be printed on such a document so long as the verbiage does not require the notary to do something that is illegal for a notary in California (i.e. certifying the authorized capacity of the signer). Please check the document carefully for proper notarial wording and attach this form if required.

- State and County information must be the State and County where the document signer(s) personally appeared before the notary public for acknowledgment.
- Date of notarization must be the date that the signer(s) personally appeared which must also be the same date the acknowledgment is completed.
- The notary public must print his or her name as it appears within his or her commission followed by a comma and then your title (notary public).
- Print the name(s) of document signer(s) who personally appear at the time of notarization.
- Indicate the correct singular or plural forms by crossing off incorrect forms (i.e. ~~he/she/they~~, is /are) or circling the correct forms. Failure to correctly indicate this information may lead to rejection of document recording.
- The notary seal impression must be clear and photographically reproducible. Impression must not cover text or lines. If seal impression smudges, re-seal if a sufficient area permits, otherwise complete a different acknowledgment form.
- Signature of the notary public must match the signature on file with the office of the county clerk.
 - ❖ Additional information is not required but could help to ensure this acknowledgment is not misused or attached to a different document.
 - ❖ Indicate title or type of attached document, number of pages and date.
 - ❖ Indicate the capacity claimed by the signer. If the claimed capacity is a corporate officer, indicate the title (i.e. CEO, CFO, Secretary).
- Securely attach this document to the signed document

Bid Bond

Recitals:

1. Mamco, Inc. "Contractor", has submitted his/her Contractor's Proposal to County of Riverside, "County", for the construction of public work for Temescal Canyon Road and Dos Lagos Drive, Street Improvements Project, El Cerrito Area Adjacent to the City of Corona Project No. C2-0154 in accordance with a Notice Inviting Bids from the County.
2. Philadelphia Indemnity Insurance Company a Pennsylvania corporation, hereafter called "Surety", is the surety of this bond.

Agreement:

We, Contractor as Principal and Surety as Surety, jointly and severally agree and state as follows:

1. The amount of the obligation of this bond is 10% of the amount of the Contractor's Proposal, including bid alternates, and inures to the benefit of County.
2. This Bond is exonerated by (1) County rejecting said Proposal or, in the alternate, (2) if said Proposal is accepted, Contractor executes the Agreement and furnishes the Bonds as agreed to in its Proposal, otherwise it remains in full force and effect for the recovery of loss, damage and expense of County resulting from failure of Contractor to act as agreed to in its Proposal. Some types of possible loss, damage and expense are specified in the Contractor's Proposal.
3. Surety, for value received, stipulates and agrees that its obligations hereunder shall in no way be impaired or affected by any extension of time within which County may accept the Proposal and waives notice of any such extension.
4. This Bond is binding on our heirs, executors, administrators, successors and assigns.

Dated: February 15, 2013

Signatures:

Philadelphia Indemnity Insurance Company

Mamco, Inc.

By: Rhonda C. Abel

By: [Signature]

Title: Attorney in Fact "Surety"

Title: Vice President "Contractor"

STATE OF COUNTY OF

ss. SURETY'S ACKNOWLEDGEMENT

SEE ATTACHED NOTARY ACKNOWLEDGMENT

On before me, personally appeared, known to me, or proved to me on the basis of satisfactory evidence, to be the person whose name is subscribed to the within instrument and acknowledged to me that he/she executed the same in his/her authorized capacities, and that by his/her signature on the instrument the person, or the entity upon behalf of which the person acted, executed the instrument.

WITNESS my hand and official seal.

Signature of Notary Public

Notary Public (Seal)

Note: This Bond must be executed by both Contractor and Surety with corporate seal affixed. All signatures must be notarized. (Attach acknowledgements).

CALIFORNIA ALL-PURPOSE COPY CERTIFICATE OF ACKNOWLEDGMENT

State of California

County of Riverside

On 2/27/13 before me, Rami M. Alabbasi, Notary Public
(Here insert name and title of the officer)

personally appeared Rumzi Alabbasi

who proved to me on the basis of satisfactory evidence to be the person(s) whose name(s) is are subscribed to the within instrument and acknowledged to me that he she they executed the same in his her their authorized capacity(ies), and that by his her their signature(s) on the instrument the person(s), or the entity upon behalf of which the person(s) acted, executed the instrument.

I certify under PENALTY OF PERJURY under the laws of the State of California that the foregoing paragraph is true and correct.

WITNESS my hand and official seal.

[Signature]
 Signature of Notary Public

(Notary Seal)

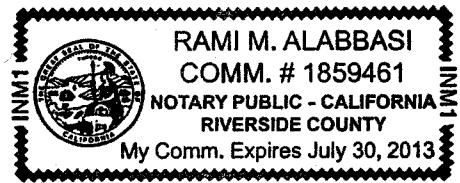

ADDITIONAL OPTIONAL INFORMATION

INSTRUCTIONS FOR COMPLETING THIS FORM

Any acknowledgment completed in California must contain verbiage exactly as appears above in the notary section or a separate acknowledgment form must be properly completed and attached to that document. The only exception is if a document is to be recorded outside of California. In such instances, any alternative acknowledgment verbiage as may be printed on such a document so long as the verbiage does not require the notary to do something that is illegal for a notary in California (i.e. certifying the authorized capacity of the signer). Please check the document carefully for proper notarial wording and attach this form if required.

- State and County information must be the State and County where the document signer(s) personally appeared before the notary public for acknowledgment.
- Date of notarization must be the date that the signer(s) personally appeared which must also be the same date the acknowledgment is completed.
- The notary public must print his or her name as it appears within his or her commission followed by a comma and then your title (notary public).
- Print the name(s) of document signer(s) who personally appear at the time of notarization.
- Indicate the correct singular or plural forms by crossing off incorrect forms (i.e. ~~he~~/she/~~they~~, is /are) or circling the correct forms. Failure to correctly indicate this information may lead to rejection of document recording.
- The notary seal impression must be clear and photographically reproducible. Impression must not cover text or lines. If seal impression smudges, re-seal if a sufficient area permits, otherwise complete a different acknowledgment form.
- Signature of the notary public must match the signature on file with the office of the county clerk.
 - ❖ Additional information is not required but could help to ensure this acknowledgment is not misused or attached to a different document.
 - ❖ Indicate title or type of attached document, number of pages and date.
 - ❖ Indicate the capacity claimed by the signer. If the claimed capacity is a corporate officer, indicate the title (i.e. CEO, CFO, Secretary).
- Securely attach this document to the signed document

DESCRIPTION OF THE ATTACHED DOCUMENT

(Title or description of attached document)

(Title or description of attached document continued)

Number of Pages _____ Document Date _____

(Additional information)

CAPACITY CLAIMED BY THE SIGNER

Individual (s)

Corporate Officer

(Title)

Partner(s)

Attorney-in-Fact

Trustee(s)

Other _____

COPY

CALIFORNIA ALL-PURPOSE ACKNOWLEDGMENT

State of California

County of Orange

On FEB 15 2013

Date

before me, K. Luu, Notary Public

Here Insert Name and Title of the Officer

personally appeared

Rhonda C. Abel

Name(s) of Signer(s)

who proved to me on the basis of satisfactory evidence to be the person(s) whose name(s) is/~~are~~ subscribed to the within instrument and acknowledged to me that ~~he~~/~~she~~/~~they~~ executed the same in ~~his~~/~~her~~/~~their~~ authorized capacity(~~ies~~), and that by ~~his~~/~~her~~/~~their~~ signature(s) on the instrument the person(s), or the entity upon behalf of which the person(s) acted, executed the instrument.

I certify under PENALTY OF PERJURY under the laws of the State of California that the foregoing paragraph is true and correct.

WITNESS my hand and official seal.

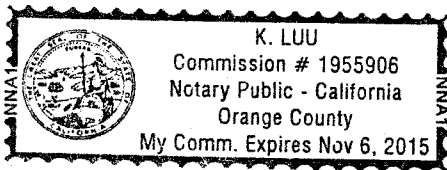

Signature _____

Signature of Notary Public

Place Notary Seal Above

OPTIONAL

Though the information below is not required by law, it may prove valuable to persons relying on the document and could prevent fraudulent removal and reattachment of this form to another document.

Description of Attached Document

Title or Type of Document: _____

Document Date: _____ Number of Pages: _____

Signer(s) Other Than Named Above: _____

Capacity(ies) Claimed by Signer(s)

Signer's Name: _____

- Individual
- Corporate Officer — Title(s): _____
- Partner — Limited General
- Attorney in Fact
- Trustee
- Guardian or Conservator
- Other: _____

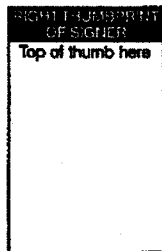

Signer Is Representing: _____

Signer's Name: _____

- Individual
- Corporate Officer — Title(s): _____
- Partner — Limited General
- Attorney in Fact
- Trustee
- Guardian or Conservator
- Other: _____



Signer Is Representing: _____

PHILADELPHIA INDEMNITY INSURANCE COMPANY
231 St. Asaph's Rd., Suite 100
Bala Cynwyd, PA 19004-0950

COPY

Power of Attorney

KNOW ALL PERSONS BY THESE PRESENTS: that **PHILADELPHIA INDEMNITY INSURANCE COMPANY** (the Company), a corporation organized and existing under the laws of the Commonwealth of Pennsylvania, does hereby constitute and appoint: [RACHELLE C. RHEAULT, JERI APODACA, KIM LUU AND RHONDA C. ABEL OF ALLIANT INSURANCE SERVICES, INC.] its true and lawful Attorney(s) in fact with full authority to execute on its behalf bonds, undertakings, recognizances and other contracts of indemnity and writings obligatory in the nature thereof, issued in the course of its business and to bind the Company thereby, in an amount not to exceed \$5,000,000.00.]

This Power of Attorney is granted and is signed and sealed by facsimile under and by the authority of the following Resolution adopted by the Board of Directors of PHILADELPHIA INDEMNITY INSURANCE COMPANY at a meeting duly called the 1st day of July, 2011.

RESOLVED: That the Board of Directors hereby authorizes the President or any Vice President of the Company to: (1) Appoint Attorney(s) in Fact and authorize the Attorney(s) in Fact to execute on behalf of the Company bonds and undertakings, contracts of indemnity and other writings obligatory in the nature thereof and to attach the seal of the Company thereto; and (2) to remove, at any time, any such Attorney-in-Fact and revoke the authority given. And, be it

FURTHER RESOLVED: That the signatures of such officers and the seal of the Company may be affixed to any such Power of Attorney or certificate relating thereto by facsimile, and any such Power of Attorney so executed and certified by facsimile signatures and facsimile seal shall be valid and binding upon the Company in the future with the respect to any bond or undertaking to which it is attached.

IN TESTIMONY WHEREOF, PHILADELPHIA INDEMNITY INSURANCE COMPANY HAS CAUSED THIS INSTRUMENT TO BE SIGNED AND ITS CORPORATE SEAL TO BE AFFIXED BY ITS AUTHORIZED OFFICE THIS 15TH DAY OF NOVEMBER 2012.

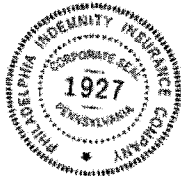

(Seal)

Sean S. Sweeney

President

Sean S. Sweeney, President
Philadelphia Indemnity Insurance Company

On this 15th day of November 2012, before me came the individual who executed the preceding instrument, to me personally known, and being by me duly sworn said that he is the therein described and authorized officer of the **PHILADELPHIA INDEMNITY INSURANCE COMPANY**; that the seal affixed to said instrument is the Corporate seal of said Company; that the said Corporate Seal and his signature were duly affixed.

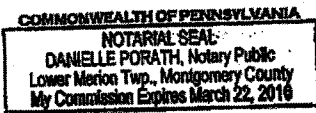

Notary Public:

Danielle Porath

residing at:

Bala Cynwyd, PA

(Notary Seal)

My commission expires:

March 22, 2016

I, Craig P. Keller, Executive Vice President, Chief Financial Officer and Secretary of PHILADELPHIA INDEMNITY INSURANCE COMPANY, do hereby certify that the foregoing resolution of the Board of Directors and this Power of Attorney issued pursuant thereto are true and correct and are still in full force and effect. I do further certify that Sean S. Sweeney, who executed the Power of Attorney as President, was on the date of execution of the attached Power of Attorney the duly elected President of PHILADELPHIA INDEMNITY INSURANCE COMPANY,

FEB 15 2013

In Testimony Whereof I have subscribed my name and affixed the facsimile seal of each Company this _____ day of _____ 20____.

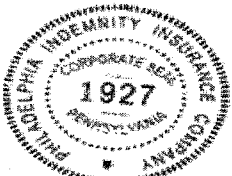

Craig P. Keller
Craig P. Keller, Executive Vice President, Chief Financial Officer & Secretary
PHILADELPHIA INDEMNITY INSURANCE COMPANY

COPY

Company Profile

PHILADELPHIA INDEMNITY INSURANCE COMPANY
ONE BALA PLAZA SUITE 100
BALA CYNWYD, PA 19004
800-564-7766

Agent for Service of Process
NANCY FLORES, C/O CT CORPORATION SYSTEM 818 WEST SEVENTH STREET LOS ANGELES, CA 90017
Unable to Locate the Agent for Service of Process?

Reference Information

NAIC #:	18058
NAIC Group #:	3098
California Company ID #:	3576-6
Date authorized in California:	January 27, 1993
License Status:	UNLIMITED-NORMAL
Company Type:	Property & Casualty
State of Domicile:	PENNSYLVANIA

Lines of Insurance Authorized to Transact

The company is authorized to transact business within these lines of insurance. For an explanation of any of these terms, please refer to the glossary.

AUTOMOBILE
BOILER AND MACHINERY
BURGLARY
FIRE
LIABILITY
MARINE
MISCELLANEOUS
PLATE GLASS
SPRINKLER
SURETY

Company Complaint Information

[Company Enforcement Action Documents](#)
[Company Performance & Comparison Data](#)
[Composite Complaint Studies](#)

Want More?

[Help Me Find a Company Representative in My Area](#)

Last Revised - November 10, 2012 10:58 AM
Copyright © California Department of Insurance

This addendum has been prepared under the direction of the following registered Civil Engineer(s):

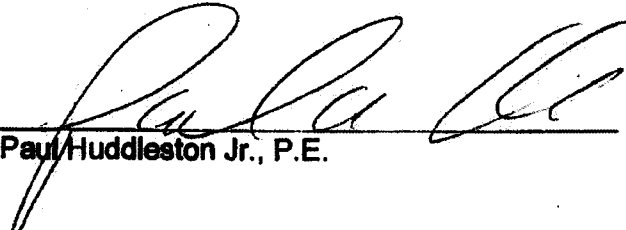
Paul Huddleston Jr., P.E.

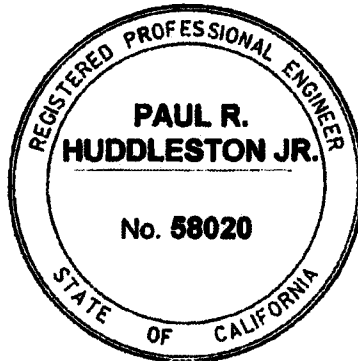

Recommended by:



Cindi Wachi, PE
County Project Manager

Concurrence:

 2/14/13
Khalid Nasim, PE
Engineering Division Manager

Acknowledged:

JRJ:rr:sb

(Contractor)
Rumzi Alabbasi- Vice President
Mamco, Inc. dba Alabbasi

Date: February 27, 2013



**COUNTY OF RIVERSIDE
TRANSPORTATION AND
LAND MANAGEMENT AGENCY**



Juan C. Perez, P.E., T.E.
Director of Transportation

Transportation Department

ADDENDUM NUMBER 2
Dated February 20, 2013

to the
**Specifications and Contract Documents
for the construction of**

**Temescal Canyon Road and Dos Lagos Drive
Street Improvements Project
El Cerrito Area Adjacent to the City of Corona
Project No. C2-0154**

Bids Due: (REVISED)
Wednesday, February 27, 2013; 2:00 PM
14th Street Transportation Annex
3525 14th Street; Riverside, CA 92501
(951) 955-6780

This Addendum is issued pursuant to the Instructions to Bidders, Item No. 8, of the Contract Documents for the reference project. This Addendum is issued as a supplement to the specification and special provisions for the referenced project. The revisions to the specifications shall become a part of the Contract Documents, and each bidder shall acknowledge receipt thereof on the Contractor's Proposal. Bidders are directed to sign this addendum as acknowledged, and attach the signed addendum to the contractor's submitted proposal.

Note: During the advertisement period of this project, this document and attachments (if any) are available upon request at the office of the Transportation Department, and are available as a free download at the Transportation Department's website:

http://www.rctlma.org/trans/con_bid_advertisements.html

MODIFICATIONS / CLARIFICATIONS TO SPECIAL PROVISIONS:

Item 1: The new designated date and time for the receipt and opening of bids is revised as follows:

Wednesday, February 27, 2013; 2:00 PM
14th Street Transportation Annex
3525 14th Street; Riverside, CA 92501
(951) 955-6780

Recommended by

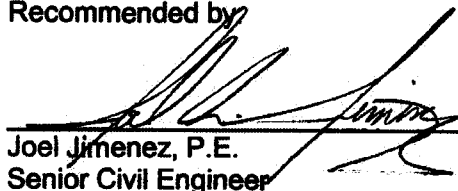
Joel Jimenez, P.E.
Senior Civil Engineer

Acknowledged:
(Contractor)
JRJ:jrj:rr

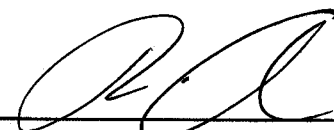
Rumzi Alabbasi- Vice President
Mamco, Inc. dba Alabbasi

Date: February 27, 2013

Addendum No. 3
Temescal Canyon Road and Dos Lagos Drive
Street Improvements Project, El Cerrito Area Adjacent to the City of Corona
Project No. C2-0154
February 21, 2013
Page 4 of 4

This addendum has been prepared under the direction of the following registered Civil Engineer(s):

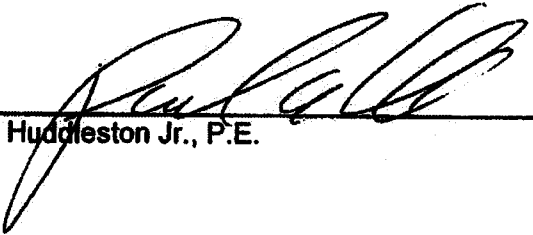

Paul Huddleston Jr., P.E.



Recommended by:



Cindi Wachi, PE
County Project Manager

Concurrence:

Signature in file

Khalid Nasim, PE
Engineering Division Manager

Acknowledged:



(Contractor)

Date: February 27, 2013

JRJ:jjr:rr

Rumzi Alabbasi- Vice President
Mamco, Inc. dba Alabbasi

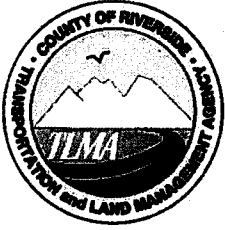

COUNTY OF RIVERSIDE TRANSPORTATION AND LAND MANAGEMENT AGENCY



ADDENDUM NUMBER 4

Dated February 25, 2013

to the

Specifications and Contract Documents
for the construction of

Temescal Canyon Road and Dos Lagos Drive
Street Improvements Project
El Cerrito Area Adjacent to the City of Corona
Project No. C2-0154

Bids Due:

Wednesday, February 27, 2013; 2:00 PM
14th Street Transportation Annex
3525 14th Street, Riverside, CA 92501
(951) 955-6780

This Addendum is issued pursuant to the Instructions to Bidders, Item No. 8, of the Contract Documents for the reference project. This Addendum is issued as a supplement to the specification and special provisions for the referenced project. The revisions to the specifications shall become a part of the Contract Documents, and each bidder shall acknowledge receipt thereof on the Contractor's Proposal. Bidders are directed to sign this addendum as acknowledged, and attach the signed addendum to the contractor's submitted proposal.

Note: During the advertisement period of this project, this document and attachments (if any) are available upon request at the office of the Transportation Department, and are available as a free download at the Transportation Department's website:

http://www.rcltma.org/trans/con_bid_advertisements.html

Item 1: Estimated Quantity Revision. Refer to Addendum No. 3, Attachment "A", Item 8 on revised bid proposal and make correction to the estimated quantity. Bidders are instructed to strikethrough and revise the estimated quantity for the listed bid item, and to submit a bid for the revised quantity of work. In the event that a bidding contractor fails to adjust the quantity as directed by this addendum, the subtotal bid price for this item will be corrected by multiplying the submitted unit bid price by the revised estimated quantity.

Item No.	Item Code	Item	Unit	Estimated Quantity
8	017305	MINOR CONCRETE (CURB AND GUTTER) (CRS 201)	LF	500

Prepared by:

Joel Jimenez, PE; Senior Civil Engineer, Contracts/Bidding Unit

Acknowledged:

(Contractor)

Rumzi Alabbasi Vice President-

JRJ:rr

Mamco, Inc. dba Alabbasi

3525 14th Street · Riverside, CA 92501 · (951) 955-6800 · FAX (951) 955-3164

Date: February 27, 2013

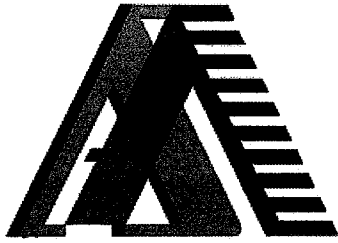

alabbasi

CONSTRUCTION AND ENGINEERING
Lic. No. 883649

Mamco, Inc. dba Alabbasi Corporate Resolution to Execute Contracts

At a meeting of the corporation today, after considerable discussion, the following resolution was moved, seconded, and unanimously adopted;

Resolved that any of the following persons, Marwan Alabbasi, Elizabeth Alabbasi, or Rumzi M. Alabbasi be; and they hereby are, authorized without further authorization of the board of directors to enter into and execute on behalf of the corporation any and all contracts to do corporate business for Mamco, Inc.

In witness whereof, I have hereunto set my hand as such secretary and affixed the corporate seal of said corporation this 1st day of October, 2012.

AUTHORIZED SIGNATURES

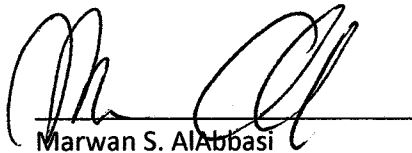

Marwan S. Alabbasi



Elizabeth Alabbasi

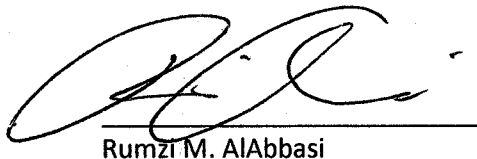

Rumzi M. Alabbasi

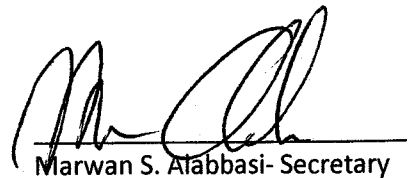

Marwan S. Alabbasi- Secretary