

FORM APPROVED COUNTY COUNSEL  
 BY: Marshall Victor  
 DATE: 4/13/13

**SUBMITTAL TO THE BOARD OF SUPERVISORS  
 COUNTY OF RIVERSIDE, STATE OF CALIFORNIA**

113A



**FROM:** TLMA - Transportation Department

**SUBMITTAL DATE:**  
 April 11, 2013

**SUBJECT:** Countywide Traffic Signal Battery Backup System and LED Modules Improvement Project at Various Locations, Phase 3

**RECOMMENDED MOTION:** That the Board of Supervisors:

1. Approve the specifications and contract documents for the Countywide Traffic Signal Battery Backup System and LED Modules Improvement Project at various locations, Phase 3, and;
2. Authorize the Clerk of the Board to advertise for bids to be received in the office of the Director of Transportation up to the hour of 2:00 p.m., Wednesday, May 15, 2013, at which time bids will be opened.

Juan C. Perez  
 Director of Transportation and Land Management

JCP:jjr:sb  
 (Continued On Attached Page)

<b>FINANCIAL DATA</b>	Current F.Y. Total Cost:	\$ 178,163	In Current Year Budget:	Yes
	Current F.Y. Net County Cost:	\$ 0	Budget Adjustment:	No
	Annual Net County Cost:	\$ 0	For Fiscal Year:	2012/2013

<b>SOURCE OF FUNDS:</b> Proposition 111(Gas Tax) (100%)	Positions To Be Deleted Per A-30	<input type="checkbox"/>
	Requires 4/5 Vote	<input type="checkbox"/>

There are no General Funds used in this project.

**C.E.O. RECOMMENDATION:**

APPROVE

BY:   
 Tina Grande

County Executive Office Signature

**MINUTES OF THE BOARD OF SUPERVISORS**

On motion of Supervisor Ashley, seconded by Supervisor Tavaglione and duly carried by unanimous vote, IT WAS ORDERED that the above matter is approved as recommended.

Ayes: Jeffries, Tavaglione, Stone, Benoit and Ashley  
 Nays: None  
 Absent: None  
 Date: April 23, 2013  
 xc: Transp., COB

Kecia Harper-Ihem  
 Clerk of the Board  
 By:   
 Deputy

Prev. Agn. Ref.

District: All

Agenda Number:

ATTACHMENTS FILED  
 WITH THE CLERK OF THE BOARD

3-64

**The Honorable Board of Supervisors**

**RE: Countywide Traffic Signal Battery Backup System and LED Modules Improvement Project at Various Locations, Phase 3**

April 11, 2013

Page 2 of 2

**BACKGROUND:**

The Transportation Improvement Program (TIP) provides for the subject improvements. This project includes replacing and retrofitting existing green and red traffic signal indications with new LED modules and installing battery backup systems throughout Riverside County at various signalized intersections in three phases. Phase 1 and Phase 2 have been completed. Phase 1 retrofitted 47 locations, and Phase 2 retrofitted 37 locations throughout the County. Phase 3 is the final phase, which includes 23 locations. A list of these locations is attached. Countywide, amber traffic signal indications were retrofitted with LED modules in 2012 under a separate project, which was federally funded by the Energy Efficiency and Conservation Block Grant (EECBG) program.

The battery backup system improvements allow traffic signals to stay in operation, or flash red, for several hours during power outages in order to maintain controlled traffic movements. These improvements will minimize traffic delays and congestion and improve safety at the signalized intersections during power outages rather than relying on drivers to stop at not-operational signals as required by the California Vehicle Code. The Transportation Department's policy requires that battery backup systems be installed in all new signal installations.

Retrofitting non-LED indications and replacing old LED indications with more energy-efficient LED hardware will reduce power consumption and prolong traffic signal operation when operating on battery power.

The submitted contract documents and specifications have been approved as to form by County Counsel.

Environmental clearance is complete.

Project No.: B9-0996

COUNTYWIDE TRAFFIC SIGNAL BATTERY BACKUP SYSTEM AND LED MODULE IMPROVEMENT PROJECT AT VARIOUS LOCATIONS, PHASE 3

No.	INTERSECTION	12" RED ARW LED	12" GRN ARW LED	12" RED BALL LED	12" GRN BALL LED	PV RED LED	PV GRN LED
1	VAN BUREN BLV	2	2	7	7	1	1
2	WOOD RD	6	10	12	12	-	-
3	WOOD RD	3	6	9	9	-	-
4	HARVILL AVE	-	-	-	-	-	-
5	DUNLAP DR	8	8	12	12	-	-
6	RAMONA EXPY	4	4	10	10	-	-
7	RAMONA EXPY	8	8	10	10	-	-
8	MOUNTAIN	1	3	10	9	1	1
9	GRAND AVE	5	6	11	11	-	-
10	GRAND AVE	2	4	9	8	-	-
11	LEON RD	8	8	13	13	-	-
12	LEON RD	4	4	13	13	-	-
13	WASHINGTON ST	8	8	14	14	-	-
14	BENTON RD	4	4	13	13	-	-
15	BENTON RD	4	4	14	14	-	-
16	BENTON RD	4	4	14	14	-	-
17	POURROY RD	2	4	11	10	-	-
18	POURROY RD	4	4	14	14	-	-
19	BUTTERFIELD STAGE RD	8	8	12	12	-	-
20	CHERRY VALLEY BLV	8	8	11	11	-	-
21	BEAUMONT AVE	6	6	8	8	2	2
22	BEAUMONT AVE	8	8	12	12	-	-
23	DILLON RD	4	4	12	12	4	4
<b>TOTAL</b>		<b>111</b>	<b>125</b>	<b>251</b>	<b>248</b>	<b>8</b>	<b>8</b>

# COUNTY WIDE BATTERY BACKUP & LED RETROFIT PROJECT PHASE 3

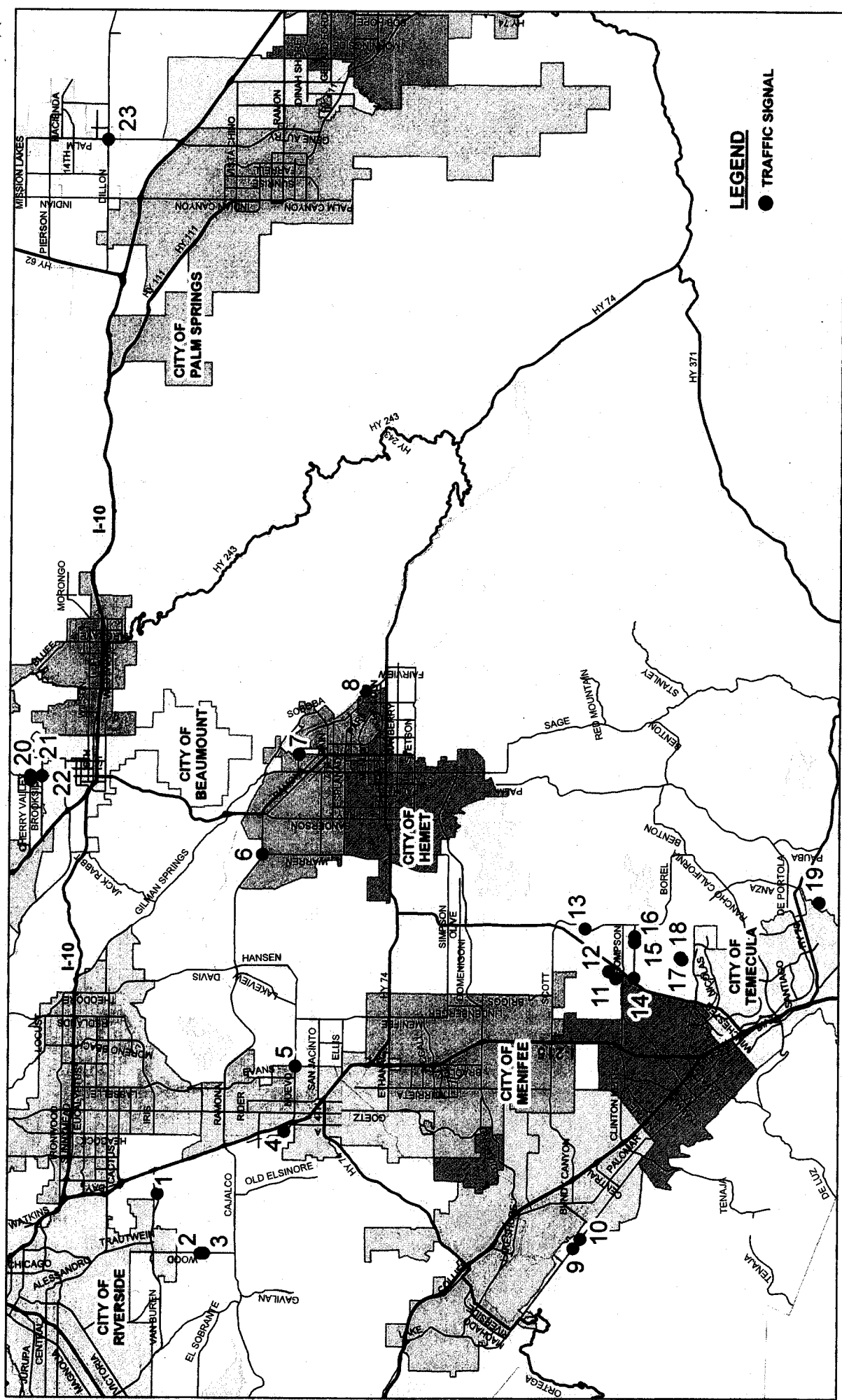

# SPECIFICATIONS and CONTRACT DOCUMENTS

for the

## CONSTRUCTION

of

COUNTYWIDE TRAFFIC SIGNAL  
BATTERY BACKUP SYSTEM AND  
LED MODULES IMPROVEMENT PROJECT  
AT VARIOUS LOCATIONS  
PHASE-3

PROJECT NO. B9-0996



# TRANSPORTATION DEPARTMENT

APR 23 2013 3-64 p/s

FORM APPROVED COUNTY COUNSEL  
BY: Marshall Victor 4/3/13  
MARSHAL L. VICTOR DATE

**COUNTYWIDE TRAFFIC SIGNAL  
BATTERY BACKUP SYSTEM AND  
LED MODULES IMPROVEMENT PROJECT  
AT VARIOUS LOCATIONS  
PHASE-3**

**PROJECT NO. B9-0996**

**Specification and Contract Documents**

for the construction of

**Countywide Traffic Signal Battery Backup System**

**And LED Modules Improvement Project**

**At Various Locations**

**Phase-3**

**Project No. B9-0996**

**Contract Approval(s):**

**Approval:**



3/20/13

Khalid Nasim, PE  
Engineering Division Manager

Date

**Engineering Certification(s)**

These specifications, special provisions, and estimates have been prepared by or under the direction of the following Registered Civil Engineer(s):

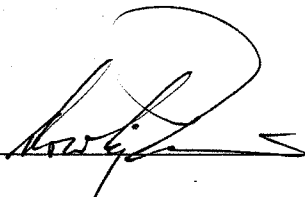

Dowling Tsai, PE

3/20/13

Date



# TABLE OF CONTENTS

	<u>PAGE</u>
Notice Inviting Bids	
Instruction to Bidders	A1-A6
Contractor's Proposal	B1-B4
Non-Collusion Affidavit	B5
Bid Bond	B6
Agreement	C1-C3
Performance Bond	C4
Payment Bond	C5
General Conditions	1-21
Definitions	1
Standard Specifications	1
Director of Transportation	2
Site Inspection	3
Protection of Premises	4
Change Orders	5
Substitution of Equals	6
Final Inspection - Notice of Completion	7
Termination of Contracts	7
Payments and Monthly Estimates	8
Force Account Payment	9
Final Payment	10
Damages	10
Documents of Contractor	11
Responsibility of Contractor in Emergency	11
Labor Code	11
Obstructions	12
Insurance - Hold Harmless	12
Equal Employment Opportunity	15
Deposit of Securities	16
Assignment of Claims	17
Claims Resolution	17
Dust Abatement	18
AQMD Requirements	22-47
Special Provisions	48-68
Appendix "A" (List of Traffic Signal Locations & map)	2-Pages
Reference Drawings	



SPECIAL PROVISIONS .....	48
DESCRIPTION:.....	48
SPECIFICATIONS:.....	48
DISPOSAL OF EXCESS EXCAVATION OR MATERIALS:.....	48
RECORD DRAWINGS:.....	49
LIQUIDATED DAMAGES:.....	49
ITEMS OF WORK.....	50
TRAFFIC CONTROL SYSTEM:.....	50
GRAFFITI REMOVAL AND CLEANING:.....	52
MAINTAINING TRAFFIC:.....	53
MINOR CONCRETE SIDEWALK (MAINTENANCE PAD): .....	54
CONDUCTORS AND CIRCUIT BREAKER REPLACEMENT: .....	54
LIGHT EMITTING DIODE (LED) TRAFFIC SIGNAL MODULES:.....	55
LED CIRCULAR SIGNAL MODULE .....	55
LED PROGRAMMED VISIBILITY (PV) SIGNAL MODULE.....	57
WARRANTY.....	57
BATTERY BACK-UP SYSTEM (BBS):.....	58
Operation.....	59
Mounting / Configuration.....	61
Internal mounted battery option .....	62
External battery cabinet option .....	62
Maintenance, Displays, Controls and Diagnostics.....	64
Battery System .....	64
Battery Harness .....	65
BBS Quality Assurance.....	65
OBSTRUCTIONS:.....	66
DE-MOBILIZATION:.....	68

**NOTICE INVITING BIDS**

County of Riverside, herein called Owner, invites sealed proposals for:

**COUNTYWIDE TRAFFIC SIGNAL  
BATTERY BACKUP SYSTEM AND  
LED MODULES IMPROVEMENT PROJECT  
AT VARIOUS LOCATIONS**

**PHASE-3**

**PROJECT NO. B9-0996**

Proposal shall be delivered to the Riverside County Transportation Department, 14<sup>th</sup> Street Annex, 3525 14<sup>th</sup> Street, Riverside, California 92501, telephone (951) 955-6780 not later than 2:00 p.m., on Wednesday, May 15, 2013, to be promptly opened in public at said address. Each proposal shall be in accordance with plans, specifications, and other contract documents, dated March 2013, and prepared by County of Riverside, whose address is same as the above, from whom they may be obtained upon deposit of \$25 per set, plus mailing. No refund. Prospective bidders may preview the plans, specifications and other contract documents, at no charge prior to purchase, at the above noted location.

The Contractor is required to have a Class "A" license or Class "C-10" License at the time of bid submission.

Dated: April 23, 2013

Kecia Harper-Ihem, Clerk of the Board

By: \_\_\_\_\_  
Deputy

## INSTRUCTIONS TO BIDDERS

1. Form of Proposal. The proposal must be made on the form of Contractor's Proposal which is included in the Contract Documents and must be completely filled in, dated and signed. If provision is made for alternates, they must all be bid, unless otherwise provided in the Special Provisions.
2. Bid Bond. The proposal must be accompanied by a 10% Bid Bond, using the form provided in the Contract Documents, or by a certified or cashier's check payable to the order of County in an amount not less than 10% of the amount bid, inclusive of alternates.
3. Submission of Proposal. A proposal must be submitted in a sealed opaque envelope which clearly identifies the bidder and the project. Bids must be received by the time and at the place set forth in the Notice Inviting Bids and may be withdrawn only as stated in the proposal. Bids shall be completed in ink.
4. Contract Documents. The complete Contract Documents are identified in the Agreement. Potential bidders are cautioned that the successful bidder incurs duties and obligations under all of the Contract Documents and that they should not merely examine the Plans and Specifications in making their bid.
5. License. To be considered for award of the contract, a potential bidder must have the kind of license required under provisions of the California Business and Professions Code for the work covered in this proposal. This includes joint ventures.

Each item of work will be performed by a Contractor which is qualified and properly licensed for that work.

Pursuant to California Labor Code Section 3099, certification is required for all persons who perform work as electricians for Contractors licensed as Class C-10 Electrical Contractors. Proof of certification shall be provided to the County before the start of construction.

6. Quantities. The amount of work to be done or materials to be furnished under the Contract as shown in the Contractor's Proposal are but estimates and are not to be taken as an expressed or an implied statement that the actual amount of work or materials will correspond to the estimate.

County reserves the right to increase or decrease or to entirely eliminate certain items from the work or materials to be furnished if such action is found to be desirable or expedient.

Contractor is cautioned against the unbalancing of his bid by prorating his overhead only into one or two items when there are a number of items listed in the schedule.

7. Interpretation of Documents. Discrepancies, omissions, ambiguities, requirements likely to cause disputes between trades and similar matter shall be promptly brought to the attention of the County of Riverside in writing. When appropriate, Addenda will be issued by County.

If the Bidder requires clarification or interpretation of the Bidding Documents, the Bidder shall make a written request to the County by a Request for Information (RFI). All requests for information must be submitted, in writing, between the hours of 8:00 AM and 5:00 PM on any day, Monday through Friday (except holidays), up to, including and no later than the fifth (5<sup>th</sup>) day prior to Bid Closing Deadline, by hand delivery, mail, fax or electronic mail. The County of Riverside will not respond to Requests for Information submitted after that time, unless the County determines, at its sole discretion, which it is in the best interest of the public and the County to do so. Requests for Information should be addressed to: County of Riverside, Transportation Department, Attn: Joel Jimenez; 3525 14<sup>th</sup> Street, Riverside, CA 92501, facsimile (951) 955-3164, electronic mail: [jjimenez@rctlma.org](mailto:jjimenez@rctlma.org)

No communication by anyone as to such matters except by an Addendum affects the meaning or requirements of the Contract Documents.

8. Addenda. County reserves the right to issue Addenda to the Contract Documents at any time prior to the time set to open bids. Each potential bidder shall leave with the County Transportation Department his name and address for the purpose of receiving Addenda to be mailed or delivered to such names at such addresses. To be considered, a Contractor's Proposal must list and take into account all issued Addenda.
9. Inspection of Site. Bidders must examine the site and acquaint themselves with all conditions affecting the work. By making his bid a bidder warrants that he has made such site examination as he deems necessary as to the condition of the site, its accessibility for materials, workmen and utilities and ability to protect existing surface and subsurface improvements. No claim for allowances - time or money - will be allowed as to such matters.
10. Bonds. The County requires a 100% Payment Bond and 100% Performance Bond from the successful bidder. All Bonds must be on County's forms contained in the Contract Documents.

The bonds must be underwritten by a Surety Company, which is admitted to transact the business of insurance in the State of California, and which carries a rating in the current issue of Best's Insurance Guide of "A" or better with a financial size of at least "VIII". The bond forms included in the project documents shall be used. All signatures on the bonds shall be notarized. Bonds shall be provided with an executed Power of Attorney issued by the surety.

11. Bids. Bids are required for the entire work, including all alternate bid schedules, if applicable, unless otherwise explicitly allowed in the bid documents. The amount of the bid for comparison purposes will be the total of all items. The total of unit basis items will be determined by extension of the item price bid on the basis of the estimated quantity set forth for the item.

The bidder shall set forth for each item of work in clearly legible figures, an item price and a total for the item in the respective spaces provided for this purpose. In the case of unit basis items, the amount set forth under the "Total" column shall be the extension of the item price bid on the basis of the estimated quantity for the item.

In case of discrepancy between the item price and the total set forth for the item, the item price shall prevail, provided, however, if the amount set forth as an item price is ambiguous, unintelligible or uncertain for any cause, or is omitted, or in the case of unit basis items, is the same amount as the entry in the "Total" column, then the amount set forth in the "Total" column for the item shall prevail in accordance with the following:

- a. As to lump sum items, the amount set forth in the "Total" column shall be the item price.
- b. As to unit basis items, the amount set forth in the "Total" column shall be divided by the estimated quantity for the item and the price thus obtained shall be the item price.

The bidder is advised that the items of work may be grouped into bid schedules, and that certain bid items may be listed in more than one bid schedule, and with different bid item numbers, and the following shall apply thereto:

The bidder is directed to submit the same bid amount for all contract bid items that are listed with the same item code and item description. Said bid items are referred to herein as "Like Bid Items".

"Like Bid Items" shall be considered a single bid item for purposes of calculating increased and decreased quantities, and as otherwise applicable in Section 4-1.03, "Changes" of the Standard Specifications.

The following are not subject to this bidding requirement:

1. Bid items with the same item code but different item descriptions.
2. Bid items that are measured as "lump sum" or "force account".
3. Alternate bid schedules.

In the event that a bidder submits different unit bid amounts for "Like Bid Items", as described above, the bid will be corrected by applying the lowest of the unit bid amounts to all the respective "Like Bid Items".

No bidder may withdraw his bid for a period of ninety (90) days after the bid opening.

12. Award of Contract. The County reserves the right to reject all bids received. Acceptance by the governing body of the County by resolution or minute order at a meeting regularly called

and held of a Contractor's Proposal constitutes an award of the contract and the execution of the Agreement is a written memorial thereof.

The County of Riverside will submit the contract documents to the low responsive and responsible bidder for execution prior to award utilizing the following procedures and requirements:

- a. A bidder whose proposal is accepted shall execute the formal construction agreement with the County of Riverside, similar to the form attached hereto as a sample, and shall return said agreement, together with approved performance and payment bonds and with complete evidence of insurance as required elsewhere herein, including executed additional insured endorsements and waivers of subrogation, within ten (10) working days from the date of the Notice of Acceptance of Proposal and Intent to Award as issued by the Transportation Department. All submittals shall meet the requirements of the bid documents. Corrections, if required, shall be made and the revised documents shall be resubmitted within two (2) working days of Contractor's receipt of review comments.
  - b. The contract bonds and insurance documentation shall be submitted in accordance with the contract requirements prior to submission to the County of Riverside Board of Supervisors for award by the Transportation Department, and prior to the performance of any work under the contract.
  - c. If a Bidder to whom a Notice of Acceptance of Proposal and Intent to Award has been issued, fails or refuses to sign a construction agreement, or to furnish the bonds or insurance certificates and endorsements as required within the prescribed period of time as described above, the County of Riverside may, at its sole discretion, rescind the Notice of Acceptance, and the bid guarantee submitted by that Contractor shall become the property of the County of Riverside as prescribed in the bid documents and as allowed by law.
  - d. If it is in the best interest of the County of Riverside, the County reserves the right to award the contract prior to execution by the Contractor. Thereafter, County shall mail or deliver to the lowest responsible bidder the agreement for Contractor's execution and return.
13. Return of Guarantee. Bid bonds will not be returned unless specifically requested by the bidder. Any submitted negotiable securities of unsuccessful bidders will be returned by mail within 30 days of the award of a contract to the successful bidder. Any submitted negotiable security of the successful bidder will be returned by mail within 30 days of receipt by the County of executed contract, certificate of insurance, performance bond and payment Bond.
14. Subletting and Subcontracting. Bidders are required pursuant to the Subletting and Subcontracting Fair Practices Act (commencing with Section 4100 of the Public Contracts Code) to list in their proposal the name and location of place of business of each subcontractor who will perform work or labor or render services in or about the construction

of the work or improvement or a subcontractor who specifically fabricates and installs a portion of the work or improvement according to detailed drawings contained in the Plans and Specifications in excess of 1/2 of 1% of this prime Contractor's total bid. Failure to list a subcontractor for a portion of the work means that the prime Contractor will do that portion of the work. It is the County's intent for the Subletting and Subcontracting Fair Practice Act to apply to all phases of the work.

15. Qualifications of Bidders. No award will be made to any bidder who cannot give satisfactory assurance to the Board of Supervisors as to his own ability to carry out the contract, both from his financial standing and by reason of his previous experience as a Contractor on work of the nature contemplated in the contract. The bidder may be required to submit his record of work of similar nature to that proposed under these specifications, and unfamiliarity with the type of work may be sufficient cause for rejection of bid.

16. Contract Participation. Riverside County's M/W/DVBE Contract Participation Program affirms the utilization and participation of qualified minority, women and disabled veteran firms in its contracting and procurement activities. The County encourages general and prime Contractors to afford competitive subcontracting opportunities to minority, women and disabled veteran firms where possible, in their contracting and procurement activities with the County of Riverside.

17. Hours of Work. Attention is directed to Section 8-1.06, "Time of Completion" and Section 7-1.01A (1), "Hours of Labor" of the Standard Specifications.

Daily working hours shall be between the hours of 7:00 a.m. and 6:00 p.m., Monday through Friday, except legal holidays, as approved by the Engineer. Exceptions and specific work schedules shall be submitted to the Engineer for consideration.

18. Labor Code. Pursuant to the Labor Code, the governing board of the Owner has obtained from the Director of the Department of Industrial Relations, State of California, his determinations of general prevailing rates of per diem wages applicable to the work, and for holiday, and overtime work, including employer payments for health and welfare, pensions, vacation and similar purpose, as set forth on schedule which is on file at the principal office of the Owner, and which will be made available to any interested person upon request.

19. Alternate Bid Schedules. If the Proposal includes bid items listed under a Base Bid Schedule and one or more Alternate Bid Schedules, the following shall apply: The County may award only the items of work listed on the Base Bid Schedule, or may choose to award some or all of the Alternate Bid Schedules in addition to the Base Bid Schedule. Unless otherwise specified, the basis of the selection of the lowest bid shall be the lowest responsive and responsible bid for the sum of all Bid Schedules.

If the Proposal includes bid items listed under two or more Alternate Bid Schedules with no Base Bid Schedule, the following shall apply: This project contains Alternate Bid Schedules that may or may not be mutually exclusive, as described elsewhere in the bid documents. The County may award the items of work listed on one or more of the Alternate Bid

Schedules. In the case of mutually exclusive Alternate Bid Schedules, only one of the Alternate Bid Schedules will be selected for award. Unless otherwise specified, the basis of the selection of the lowest bid shall be the lowest responsive and responsible bid for the sum of all Bid Schedules.

The County also reserves the right to reject all bids received.

20. Dust Abatement. Attention is directed to Section 23, "Dust Abatement" with regard to the dust abatement provisions of the contract.
21. Submission of Insurance Certificate. Within ten (10) working days of the date of the Notice of Acceptance of Proposal and Intent to Award issued by the County of Riverside, the successful Contractor shall submit a certificate of insurance, including required endorsements, which provides evidence that the bidding Contractor has insurance coverage that meets the requirements of Section 18 of the General Conditions. Failure to have complete insurance coverage in place and to provide all required certificates and endorsements within the specified ten (10) working days period will be grounds for declaring the bidder to not be in compliance with the bid documents, rescinding the Notice of Acceptance, making a claim against the bid bond, and awarding to the second low bidder, at the sole discretion of the County.



## CONTRACTOR'S PROPOSAL

TO: COUNTY OF RIVERSIDE

DATE: \_\_\_\_\_

hereafter called "County":

BIDDER: \_\_\_\_\_  
(hereafter called "Contractor")

THE UNDERSIGNED, Contractor, having carefully examined the site and the Contract Documents for the construction of COUNTYWIDE TRAFFIC SIGNAL BATTERY BACKUP SYSTEM AND LED MODULES IMPROVEMENT PROJECT AT VARIOUS LOCATIONS, PHASE-3, PROJECT NO. B9-0996 hereby proposes to construct the work in accordance with the Contract Documents, including Addenda Nos. \_\_\_\_\_ for the amount stated in this Proposal.

By submitting this Proposal, Contractor agrees with County:

1. That unless withdrawn in person by Contractor or some person authorized in writing by Contractor not by telephone or telegram before the time specified in the Notice Inviting Bids for the public opening of bids, this Proposal constitutes an irrevocable offer for 90 calendar days after that date.
2. County has the right to reject any or all Proposals and to waive any irregularities or informalities contained in a Proposal.
3. To execute the Agreement and deliver the Faithful Performance Bond, Payment Bond and Insurance Certificate with endorsements, which comply with the requirements set forth in the Instructions to Bidders and General Conditions, within ten (10) working days of the date of the Notice of Acceptance of Proposal and Intent to Award as issued by the County of Riverside.
4. That the contract shall be awarded upon a resolution or minute order to that effect duly adopted by the governing body of County; and that execution of the Contract Documents shall constitute a written memorial thereof.
5. To submit to County such information as County may require to determine whether a particular Proposal is the lowest responsible bid submitted.

6. That the accompanying certified or cashier's check or Bid Bond is in an amount not less than 10% of the total bid submitted and constitutes a guarantee that if awarded the contract, Contractor will execute the Agreement and deliver the required bonds within ten (10) days after notice of award. If Contractor fails to execute and deliver said documents, the check or bond is to be charged with the costs of the resultant damages to County, including but not limited to publication costs, the difference in money between the amount bid and the amount in excess of the bid which it costs County to do or cause to be done the work involved, lease and rental costs, additional salaries and overhead, increased interest and costs of funding the project, attorney expense, additional engineering and architectural expense and cost of maintaining or constructing alternate facilities occasioned by the failure to execute and deliver said documents.
7. By signing this proposal the Contractor certifies that the representations made therein are made under penalty of perjury.

**COUNTY WIDE TRAFFIC SIGNAL BATTERY BACKUP SYSTEM  
AND LED MODULE IMPROVEMENT PROJECT  
AT VARIOUS LOCATIONS, PHASE 3**

**PROJECT NO. B9-0996**

**PROPOSAL**

ITEM No.	ITEM CODE	ITEM	UNIT	ESTIMATED QUANTITY	ITEM PRICE (IN FIGURES)	TOTAL (IN FIGURES)
1	120100	TRAFFIC CONTROL SYSTEM	LS	1		
2	000003	12" RED ARROW LED TRAFFIC SIGNAL MODULE	EA	111		
3	000003	12" GREEN ARROW LED TRAFFIC SIGNAL MODULE	EA	125		
4	000003	12" RED BALL LED TRAFFIC SIGNAL MODULE	EA	251		
5	000003	12" GREEN BALL LED TRAFFIC SIGNAL MODULE	EA	248		
6	000003	PV RED LED TRAFFIC SIGNAL MODULE	EA	8		
7	000003	PV GREEN LED TRAFFIC SIGNAL MODULE	EA	8		
8	731521	MINOR CONCRETE (SIDEWALK) (MAINTENANCE PAD)	SQFT	162		
9	000003	CONDUCTOR REPLACEMENT (SERVICE CABINET TO CONTROLLER CABINET)	LF	2,430		
10	000003	BATTERY BACK-UP SYSTEM (MOUNT EXTERNALLY TO CONTROLLER CABINET)	EA	17		
11	000003	BATTERY BACK-UP SYSTEM (MOUNT INTERNALLY TO CONTROLLER CABINET)	EA	6		
12	019901	DE-MOBILIZATION	LS	1	8,500.00	8,500.00

PROJECT TOTAL: \_\_\_\_\_ \$ \_\_\_\_\_  
ITEMS 1-12 "WORDS"

**BIDDER DATA:**

Name of Bidder \_\_\_\_\_

Type of Organization \_\_\_\_\_

Person(s) Authorized to Sign for Bidder \_\_\_\_\_

Address \_\_\_\_\_

\_\_\_\_\_ Phone \_\_\_\_\_

Contractor's License \_\_\_\_\_  
Type & Number

Expiration Date \_\_\_\_\_

8. **DESIGNATION OF SUBCONTRACTORS:** Contractor submits the following complete list of each subcontractor who will perform work or labor or render service in or about the construction in an amount in excess of 1/2 of 1% of the total bid.

<u>ITEM</u>	<u>SUBCONTRACTOR</u>	<u>ADDRESS</u>	<u>LICENSE NO.</u>
-------------	----------------------	----------------	--------------------

**Percent of work to be performed by sub-contractors: \_\_\_%**  
**(Note: 50% of the work required to be performed by general contractor)**

IN WITNESS WHEREOF Contractor executed this Proposal as of the date set forth on Page 1 of this proposal.

\_\_\_\_\_  
\_\_\_\_\_  
**TITLE** \_\_\_\_\_  
"Contractor"

## Non-Collusion Declaration

To be executed by bidder and submitted with bid.  
(Title 23 United States Code Section 112 and Public Contract Code Section 7106)

The undersigned declares:

I am the \_\_\_\_\_ (Title) of \_\_\_\_\_ (Company),  
the party making the foregoing bid.

The bid is not made in the interest of, or on behalf of, any undisclosed person, partnership, company, association, organization, or corporation. The bid is genuine and not collusive or sham. The bidder has not directly or indirectly induced or solicited any other bidder to put in a false or sham bid. The bidder has not directly or indirectly colluded, conspired, connived, or agreed with any bidder or anyone else to put in a sham bid, or that anyone shall refrain from bidding. The bidder has not in any manner, directly or indirectly, sought by agreement, communication, or conference with anyone to fix the bid price of the bidder or any other bidder, or to fix any overhead, profit, or cost element of the bid price, or of that of any other bidder.

All statements contained in the bid are true. The bidder has not, directly or indirectly, submitted his or her bid price of any breakdown thereof, or the contents thereof, or divulged information or data relative thereto, to any corporation, partnership, company, association, organization, bid depository, or to any member or agent thereof to effectuate a collusive or sham bid, and has not paid, and will not pay, any person or entity for such purpose.

Any person executing this declaration on behalf of a bidder that is a corporation, partnership, joint venture, limited liability company, limited liability partnership, or any other entity, hereby represents that he or she has full power to execute, and does execute, this declaration on behalf of the bidder.

I declare under penalty of perjury under the applicable laws that the foregoing is true and correct and that this declaration is executed on

\_\_\_\_\_ (Month) \_\_\_\_\_ (Day) of \_\_\_\_\_ (Year),

at \_\_\_\_\_ (City), \_\_\_\_\_ (State).

**Signature of Declarant:** \_\_\_\_\_

**Printed name of Declarant:** \_\_\_\_\_

**Name of Bidder (Company):** \_\_\_\_\_

**Title or Office:** \_\_\_\_\_

**Note:** Notarization of signature required.

Check box if attachment is included.

## Bid Bond

**Recitals:**

1. \_\_\_\_\_ "Contractor", has submitted his/her Contractor's Proposal to County of Riverside, "County", for the construction of public work for **COUNTYWIDE TRAFFIC SIGNAL BATTERY BACKUP SYSTEM AND LED MODULES IMPROVEMENT PROJECT AT VARIOUS LOCATIONS, PHASE-3, PROJECT NO. B9-0996** in accordance with a Notice Inviting Bids from the County.
2. \_\_\_\_\_ a \_\_\_\_\_ corporation, hereafter called "Surety", is the surety of this bond.

**Agreement:**

We, Contractor as Principal and Surety as Surety, jointly and severally agree and state as follows:

1. The amount of the obligation of this bond is 10% of the amount of the Contractor's Proposal, including bid alternates, and inures to the benefit of County.
2. This Bond is exonerated by (1) County rejecting said Proposal or, in the alternate, (2) if said Proposal is accepted, Contractor executes the Agreement and furnishes the Bonds as agreed to in its Proposal, otherwise it remains in full force and effect for the recovery of loss, damage and expense of County resulting from failure of Contractor to act as agreed to in its Proposal. Some types of possible loss, damage and expense are specified in the Contractor's Proposal.
3. Surety, for value received, stipulates and agrees that its obligations hereunder shall in no way be impaired or affected by any extension of time within which County may accept the Proposal and waives notice of any such extension.
4. This Bond is binding on our heirs, executors, administrators, successors and assigns.

Dated: \_\_\_\_\_

Signatures:

\_\_\_\_\_

\_\_\_\_\_

By: \_\_\_\_\_

By: \_\_\_\_\_

Title:            Attorney in Fact  
                         "Surety"

Title: \_\_\_\_\_  
                         "Contractor"

STATE OF \_\_\_\_\_ }  
COUNTY OF \_\_\_\_\_ }

ss. SURETY'S ACKNOWLEDGEMENT

On \_\_\_\_\_ before me, \_\_\_\_\_ personally appeared, \_\_\_\_\_ known to me, or proved to me on the basis of satisfactory evidence, to be the person whose name is subscribed to the within instrument and acknowledged to me that he/she executed the same in his/her authorized capacities, and that by his/her signature on the instrument the person, or the entity upon behalf of which the person acted, executed the instrument.

WITNESS my hand and official seal.

\_\_\_\_\_  
Signature of Notary Public

Notary Public (Seal)

**Note: This Bond must be executed by both Contractor and Surety with corporate seal affixed. All signatures must be notarized. (Attach acknowledgements).**

**AGREEMENT**

THIS AGREEMENT is entered into at Riverside, California as of the date set forth below is between County of Riverside hereafter called "County" and \_\_\_\_\_ hereafter called "Contractor".

W I T N E S S E T H

RECITALS:

1. Contractor has submitted to County his Contractor's Proposal for the construction of County Project, \_\_\_\_\_  
in strict accordance with the Contract Documents identified below and County has accepted said Proposal.
2. Contractor states that he has reexamined his Contractor's Proposal and found it to be correct, has ascertained that his subcontractors are properly licensed and possess the requisite skill and forces, has reexamined the site and Contract Documents and is of the opinion that he can presently do the work in accordance with the Contract Documents for the money set forth in his Proposal to be paid as provided in the Contract Documents.

AGREEMENT:

IT IS AGREED BY THE PARTIES AS FOLLOWS:

1. Contract Documents. The entire contract consists of the following: (a) The Agreement. (b) The Notice Inviting Bids. (c) The Instruction to Bidders. (d) The Contractor's Proposal. (e) The Bid Bond. (f) The Payment Bond. (g) The Performance Bond. (h) The General Conditions. (i) The Special Provisions. (j) The Standard Specifications of the State of California Department of Transportation edition of May 2006 as modified in other portions of the Contract Documents. (k) The Standard Plans of the Department of Transportation identified on the plans or in the Special Provisions. (l) The Plans. (m) Addenda No. \_\_\_\_\_. (n) The Determination of Prevailing Wage Rates for Public Work. (o) Any Change Orders issued. (p) Any additional or supplemental specifications, notice, instructions and drawings issued in accordance with the provisions of the Contract Documents. All of said Documents presently in existence are by this reference incorporated herein with like effect as if here set forth in full and upon the proper issuance of other documents they shall likewise be deemed incorporated. The Bid Bond is exonerated upon execution of this Agreement and the Payment Bond and Faithful Performance Bond.
2. The Work. Contractor shall do all things necessary to construct the work generally described in Recital No. 1 in accordance with the Contract Documents.

3. Liquidated Damages and Time of Completion. Attention is directed to the provisions in Section 8-1.06, "Time of Completion", and in Section 8-1.07, "Liquidated Damages", of the Standard Specifications and these Special Provisions.

The Contractor shall begin work within 15 days of the date stated within the written "Notice to Proceed".

The Contractor shall notify the Engineer, in writing, of his intent to begin work at least 72 hours before work is begun. The notice shall be delivered to the Transportation Department's Construction Engineer and shall specify the date the Contractor intends to start. If the project has more than one location of work, a separate notice shall be given for each location.

Should the Contractor begin work in advance of receiving a written "Notice to Proceed", any work performed by him in advance of the date stated in the "Notice to Proceed" shall be considered as having been done by him at his own risk and as a volunteer and subject to the following:

- (1) The Contractor shall, on commencing operations, take all precautions required for public safety and shall observe all the provisions in the Specifications and the Special Provisions.
- (2) All work done according to the contract prior to the issuance of the "Notice to Proceed", will be considered authorized work and will be paid for as provided in the contract.
- (3) The Contractor shall not be entitled to any additional compensation or an extension of time for any delay, hindrance or interference caused by or attributable to commencement of work prior to the issuance of the "Notice to Proceed".

4. Compensation. Contractor shall be paid in the manner set forth in the Contract Documents the amount of his Proposal as accepted by County, the above rates, subject to additions and deductions as provided in the Contract Documents. Said Proposal is on file in the Office of the Clerk of the Board of Supervisors of County.



**Countywide Traffic Signal  
Battery Backup System and  
LED Modules Improvement Project  
At Various Locations  
Project No. B9-0996**

IN WITNESS WHEREOF the parties hereto have executed this agreement as of the date set forth below.

COUNTY OF RIVERSIDE

CONTRACTOR

BY \_\_\_\_\_  
Chairman, Board of Supervisors

BY \_\_\_\_\_

Dated \_\_\_\_\_

TITLE: \_\_\_\_\_  
(If Corporation, Affix Seal)

ATTEST:

Kecia Harper-Ihem, Clerk of the Board

ATTEST:

\_\_\_\_\_

BY \_\_\_\_\_  
Deputy

TITLE: \_\_\_\_\_

Licensed in accordance with an act providing for the registration of Contractors,

License No. \_\_\_\_\_

Federal Employer Identification Number:  
\_\_\_\_\_

\_\_\_\_\_  
"County"  
(Seal)

\_\_\_\_\_  
"Corporation"  
(Seal)

# Performance Bond

## Recitals:

1. \_\_\_\_\_ (Contractor) has entered into an Agreement with COUNTY OF RIVERSIDE (County) for construction of public work known as \_\_\_\_\_.
2. \_\_\_\_\_, a \_\_\_\_\_ corporation (Surety), is the Surety under this Bond.

## Agreement:

We, Contractor as Principal and Surety as Surety, jointly and severally agree, state, and are bound unto County, as obligee, as follows:

1. The amount of the obligation of this Bond is 100% of the estimated contract price for the Project of \$ \_\_\_\_\_ and inures to the benefit of County.
2. This Bond is exonerated by Contractor doing all things to be kept and performed by it in strict conformance with the Contract Documents for this project, otherwise it remains in full force and effect for the recovery of loss, damage and expense of County resulting from failure of Contractor to so act. All of said Contract Documents are incorporated herein.
3. This obligation is binding on our successors and assigns.
4. For value received, Surety stipulates and agrees that no change, time extension, prepayment to Contractor, alteration or addition to the terms and requirements of the Contract Documents or the work to be performed thereunder shall affect its obligations hereunder and waives notice as to such matters, except the total contract price cannot be increased by more than 10% without approval of Surety.

THIS BOND is executed as of \_\_\_\_\_.

By \_\_\_\_\_

By \_\_\_\_\_

By \_\_\_\_\_

Type Name \_\_\_\_\_

Its Attorney in Fact  
"Surety"

Title \_\_\_\_\_

"Contractor"

(Corporate Seal)

(Corporate Seal)

**NOTE: This Bond must be executed by both parties with corporate seal affixed. All signatures must be acknowledged. (Attach acknowledgements).**

**Payment Bond**

(Public Works - Civil Code §9550 et seq.)

The makers of this Bond are \_\_\_\_\_, as Principal and Original Contractor and \_\_\_\_\_, a corporation, authorized to issue Surety Bonds in California, as Surety, and this Bond is issued in conjunction with that certain public works contract to be executed between Principal and COUNTY OF RIVERSIDE a public entity, as Owner, for \$ \_\_\_\_\_, the total amount payable. The amount of this bond is one hundred percent (100%) of said sum. Said contract is for public work generally consisting of \_\_\_\_\_.

The beneficiaries of this Bond are as is stated in 9554 of the Civil Code and requirements and conditions of this Bond are as is set forth in 9554, 9558, 9560 and 9564 of said code. Without notice, Surety consents to extension of time for performance, change in requirements, amount of compensation, or prepayment under said contract.

Dated: \_\_\_\_\_

\_\_\_\_\_  
Original Contractor – Principal

\_\_\_\_\_  
Surety

By \_\_\_\_\_

By \_\_\_\_\_

Title \_\_\_\_\_

Its Attorney In Fact

(If corporation, affix seal)

(Corporate Seal)

(Corporate Seal)

STATE OF \_\_\_\_\_ }  
COUNTY OF \_\_\_\_\_ }

ss. SURETY'S ACKNOWLEDGEMENT

On \_\_\_\_\_ before me, \_\_\_\_\_ personally appeared, \_\_\_\_\_, known to me, or proved to me on the basis of satisfactory evidence, to be the person whose name is subscribed to the within instrument and acknowledged to me that he executed the same in his authorized capacities, and that by his signature on the instrument the person, or the entity upon behalf of which the person acted, executed the instrument.

WITNESS my hand and official seal.

\_\_\_\_\_  
Signature of Notary Public

Notary Public (Seal)

**NOTE: This Bond must be executed by both parties with corporate seal affixed. All signatures must be acknowledged. (Attach acknowledgements).**

GENERAL CONDITIONS

SS 1. DEFINITIONS:

- a. "County", "Contractor", and "Contract Documents" are identified in the Agreement. "County" and "Contractor" includes their authorized representatives are treated throughout as if each were singular in number. "Contractor" includes its surety.
- b. "Engineer" and "Director of Transportation" means the Director of Transportation for the County of Riverside, and includes his authorized representatives.
- c. "Plans" means the portion of the Contract Documents consisting of all drawings prepared for the direction and characteristics of the work. A schedule of said drawings which constitutes the plans as of the execution of the Agreement is set forth in the Special Provisions and are supplemented by the Standard Plans referred to in the Special Provisions.
- d. "State of California", "Department of Transportation" and "Director of Transportation", means the County of Riverside.

SS 2. STANDARD SPECIFICATIONS:

The Standard Specifications of the State of California Department of Transportation, edition of May 2006 hereafter called "Standard Specifications", are incorporated herein as modified in these General Conditions, the Special Provisions and the Plans.

The following subsections of the Standard Specifications are deleted:

1-1.13, 1-1.15, 1-1.18, 1-1.25, 1-1.37, 1-1.40, 2-1.01, 2-1.05, 2-1.07, 5-1.14, 7-1.165, 8-1.03, 9-1.05, 9-1.065, 9-1.10, 12-2.02.

Section 3 of the Standard Specifications is deleted.

The following deletions and additions are made from the following subsections of the Standard Specifications.

Subsection 5-1.04, add to the second paragraph at its end the following sentence: "The General Conditions govern over

all of the Contract Documents except the Special Provisions, the Agreement and Bonds."

Subsection 7-1.01A (2), strike the last sentence of the second paragraph and in its place read: "These wage rates are on file in the Office of the County Clerk and are a part of the Contract."

Subsection 7-1.15, for "Director" read "Director of Transportation" except for last reference read "County of Riverside".

Subsection 7-1.16, delete references to Subsection 7-1.165.

Subsection 8-1.06, strike the last paragraph.

Subsection 8-1.08, strike "as provided in the State Contract Act".

SS 3. DIRECTOR OF TRANSPORTATION:

All work shall be done under the supervision of the Director of Transportation who shall determine the amount, quality, acceptability and fitness of all parts of the work, and interpret the Contract Documents. No act or omission of the Director of Transportation relieves Contractor of the duty to proceed with the work in strict conformity with the Contract Documents.

Upon request, Director of Transportation shall reduce to writing any oral order, objection, requirement or determination. Whenever Director of Transportation's approval is required it shall be in writing only.

All communications to County by Contractor shall be via Director of Transportation.

No work shall be performed on site other than during normal working hours without the knowledge and consent of Director of Transportation.

When in Director of Transportation's opinion, weather or other conditions are such that attempts to perform a portion of the work will probably result in work not in accordance with the Contract Documents, he shall so advise Contractor. When Contractor advises Director of Transportation that he intends to proceed despite such advise, he does so at his peril. The Director of Transportation may then order Contractor, in writing which specifies the portion of the work involved and the conditions warranting the issuance of the order, not to proceed on such portion of the work if (1) proceeding will in his judgment have an adverse effect on Contractor's

ability to complete the work within the stipulated time period, or (2) proceeding will in his judgment necessitate unusual tests and procedures to ascertain whether said portion of the work is in accordance with the Contract Documents. Contractor shall comply with such orders at its expense.

Nothing herein contained relieves Contractor from the duty to make independent determinations as to weather and other conditions affecting the proper completion of the work.

Failure for any reason of Director of Transportation to advise Contractor as to such matters, or to issue an order as above provided, does not relieve Contractor from the duty to accomplish the work in accordance with the Contract Documents.

As stated elsewhere, amounts shown in the Proposal and Agreement as to quantities are but estimates only. From time to time Director of Transportation shall direct Contractor as to the prosecution of the work in such a manner as to increase or decrease such estimates as to the work actually to be done. Contractor shall comply with such instructions and shall be paid only for work actually done based on the unit price set out in the Agreement.

SS 4. SITE INSPECTION - EFFECT OF OTHER IMPROVEMENTS SHOWN AND CONTRACTOR PROCEDURE:

Elsewhere in the Contract Documents reference may be made, graphically, descriptively or both, to the existence or possible existence of other improvements affecting the site and the prosecution of the work such as surface and subsurface utilities, drainage ditches and courses, buildings, fencing, retaining walls, roadways, curbs, trees, shrubs, and similar matters. Such matters are included to be used by Contractor to the extent he deems appropriate. However, it is expressly understood and agreed:

- a. Showing or describing such items does not mean that it is an exhaustive and complete presentation and that as to matters shown or described that they necessarily exist.
- b. All graphic presentations are schematic only unless the contrary is clearly set out elsewhere as to a particular matter.
- c. Whenever in the plans survey markers are shown, boundaries of the site are shown or contour lines are shown, Contractor may assume that such matters are shown in accordance with acceptable standards.

All improvements of the nature above described, whether elsewhere shown or described or not, shall, unless the contrary is elsewhere specifically directed, remain in place, undisturbed and suitably protected during the course of the work.

Whenever during the course of the work a subsurface improvement is discovered which Contractor believes is unknown to County, he shall immediately so inform Director of Transportation. Except as elsewhere provided, whenever in the course of the work it becomes apparent that the work cannot proceed without the destruction or relocation of any improvement, whether shown or described or not, Contractor shall immediately cease work affecting such improvements and notify Director of Transportation as to such circumstance and await instructions as to how to proceed.

- d. The Contractor shall be required to cooperate fully with all utility forces or forces of other public agencies engaged in relocation, lowering, altering or otherwise rearranging any facilities interfering with the progress of work or installing any facilities thereon.

The Contractor will also be required to cooperate fully with any County or State forces working on or near the project, or requiring access to the work in the performance of their duties.

SS 5. USE OF AND PROTECTION OF PREMISES AND REMOVAL OF DEBRIS:

At his expense Contractor shall:

- a. Take every precaution against injuries to persons or damage to property.
- b. Comply with regulations governing the use of the property.
- c. Store and suitably protect his apparatus, equipment, materials and supplies in an orderly fashion on site.
- d. Place on the work only such loads as are consistent with the safety of the work.
- e. Effect all cutting, fitting, or patching of his work required to make it conform to the Plans and Specifications and interrelate with other improvements or except with the consent of Director of

Transportation, cut or otherwise alter existing improvements.

- f. Protect and preserve established bench marks and monuments, make no changes in the location of such without the prior written approval of County, replace and relocate any of them which may be lost or destroyed or which require shifting because of necessary changes in grades or locations. All replacement and relocation work shall be accomplished only after approval of County and under the direct supervision and instruction of Director of Transportation.
- g. Before final payment remove all surplus materials, false work, temporary structures, debris, and similar matter resulting from his operations from the site and to put the site in an orderly condition.
- h. Construct, operate and maintain all passageways, guard fences, lights, barricades and other facilities required for protection by State or municipal laws and regulations and local conditions during the course of the work.
- i. Guard County's property from injury or loss.
- j. Take all reasonable precautions for dust and noise control and generally conduct operations so as not to constitute a nuisance.
- k. The Contractor shall be responsible for the protection of existing signs, fences, concrete curb and gutter and other highway facilities which may be encountered in the roadway. The replacement or repair of any facilities which the County deems necessary as a result of the Contractor's operations shall be done by the Contractor at his own expense and to the satisfaction of the County Transportation Department.

SS 6. CHANGE ORDERS - DETAIL DRAWINGS AND INSTRUCTIONS:

Reference is made to 4-1.03 and 4-1.03A of the Standard Specifications regarding change orders. Wherever in these subsections the word "Engineer" appears read "County".

Each approved change order shall be considered as an amendment to the Contract Documents and will not be considered approved until executed by the Board of Supervisors, except Director of Transportation can approve certain change orders without the necessity of approval by



the Board as provided in a Resolution of the Board adopted March 30, 1993, Resolution Number 93-047.

The above does not limit the ability of Director of Transportation to issue further detail drawings, explanations and instructions which are customarily given by an Engineer during the course of similar work. Director of Transportation will furnish Contractor with reasonable promptness such further detailed explanations, instructions and drawings as may be necessary for the proper execution of the work, and Contractor shall conform to same provided they are consistent with the intent of the Contract Documents. In giving such additional instructions, explanations and drawings Director of Transportation has authority to make minor changes in the work which do not involve extra cost and are not inconsistent with the Contract Documents.

Contractor's acting on such instructions, explanations and drawings of Director of Transportation means that Contractor agrees that such explanations, instructions and drawings are within the scope of the work in accordance with the intent of the Contract Documents and do not constitute a basis for modification of the Contract Documents as to price or time.

SS 7. BRAND OR TRADE NAME - SUBSTITUTE OF EQUALS:

Reference is made to Section 3400 of the Public Contracts Code, which is by this reference incorporated herein with like effect as if here set forth in full.

If a potential bidder believes he knows of an equal to a specified brand or trade name which is not mentioned in the Contract Documents, then such potential bidder may so advise Director of Transportation of such fact, giving all relevant information. If appropriate, an addendum will be issued as to the alleged equal provided that such issuance may be accomplished at least 5 days before the time fixed for opening bids.

Unless the subject article or product is expressly designated for matching others in use in a particular public improvement either completed or in the course of completion, any bidder may, as part of its bid proposal, include a request for substitution of an item equal to any specified by brand or trade name.

Within 35 calendar days after award of the contract, Contractor may submit to Director of Transportation data substantiating such a request, and the difference, if any, in cost. Director of Transportation shall promptly investigate the request and make a recommendation to County as to equality. The governing body of County shall promptly determine whether the substitute is equal in every respect

to the item specified, and approve or deny the request accordingly, and shall notify Director of Transportation of the determination made, who shall advise Contractor in writing of the decision. Unless the request is granted, substitution will not be permitted.

Nothing herein shall authorize a change in the contract price or prevent the use of change orders in the manner provided elsewhere in the Contract Documents.

SS 8. FINAL INSPECTION - NOTICE OF COMPLETION:

When the work is ready for final inspection County shall cause the work to be inspected and subjected to such tests as seem to it to be required for the purpose of determining if the work is complete in every respect.

At a meeting of the governing body of County held within 10 days after final inspection, the governing body shall consider the facts developed at the inspection. If it is found that the work is apparently complete in every respect, County will accept the work and a notice of completion will be recorded.

As between the parties, the recordation of the Notice of Completion, unless recorded because of a cessation of labor, means only that the time for final payment and the commencement of the guarantee period commences to run.

SS 9. COUNTY'S RIGHT TO STOP WORK OR TERMINATE THE CONTRACT:

(1) Contractor shall be adjudged bankrupt or make an assignment for the benefit of creditors, or (2) a receiver or liquidator is appointed for Contractor or any of his property, or (3) Contractor shall refuse or fail after Notice of Warning from County by Director of Transportation to supply sufficient properly skilled workmen or suitable materials, or (4) Contractor fails to prosecute the work with such diligence as will insure its completion within the stipulated time period, or (5) Contractor shall fail to make payments to persons supplying labor or materials for the work, or (6) Contractor does not comply with applicable law or instructions of Director of Transportation, or (7) Contractor is otherwise guilty of a substantial violation of any provision of the Contract Documents, then County without prejudice to such other and further right, remedy or relief it may be entitled to, may by 10 days notice to Contractor, terminate the employment of Contractor and his right to proceed, either as to the entire work, or at County's option, as to any portion thereof as to which delay shall have occurred or breach or noncompliance relates, and may thereupon take possession of the affected work and complete

the work by contract or otherwise, as County deems expedient. In such case Contractor shall not be entitled to receive any further payment until the work is finished. If the unpaid balance shall exceed the expense of completion, and other damage, expense or loss of County occasioned by Contractor's failure to properly perform, such excess shall be paid by Contractor. If such expense and damage exceeds the unpaid balance, Contractor is liable to County for the excess. If County elects to proceed under this Section, it may take possession of and utilize in completing the work such materials, supplies, plant and equipment on site which may be necessary or convenient for the purpose of completing the work, County is expressly granted the right - acting via Director of Transportation, an Engineer or otherwise - to operate equipment and machinery on site for the purpose of determining whether it has a basis for proceeding under this section.

If the construction of the project herein is damaged, which damage is determined to have been proximately caused by an act of God, in excess of 5% of the contract amount, provided that the work damaged is built in accordance with applicable building standards and the plans and specifications, then the Owner, upon certification by the Engineer, may, without prejudice to any other right of remedy, terminate the contract.

Decision by County not to proceed under this Section does not constitute a waiver by County of any right it might from time to time have against Contractor under the Contract Documents.

SS 10. PAYMENT AND MONTHLY ESTIMATES:

Director of Transportation, once each month, after said work is commenced and until after the completion and acceptance thereof, shall make and deliver to Contractor duplicate certificates stating the value of work then completed according to the contract, estimated according to the standard of the unit contract price, and thereupon Contractor shall be paid an amount sufficient with all previous payments to make the aggregate ninety five percent (95%) of the amount earned as certified. Maximum value of progress payment retention, as set forth in Section 9-1.06 of the Standard Specifications and any other referenced text, shall be five (5%).

The partial payments made as the work progresses will be payment on account on work performed as of the 25th of the month and shall in no way be considered as an acceptance of any part of the work or material of the contract, nor shall they in any way govern the final estimate. No such estimate or payment shall be made when in the judgement of the

Director of Transportation the total value of the work done since the last estimate amounts to less than \$300.

For the purpose of timely payment, the "receipt of payment request" date, as described in Public Contract Code 20104.50 and as referred to herein, shall be considered to be the fifth working day following the 25th day of each month.

Within 5 working days of the 25th day of each month the County shall:

- a. Calculate and prepare the certificate ("progress pay estimate") stating the value of the work completed for the billing month, for the purpose of determining the proper progress payment amount.
- b. If a progress pay estimate has been prepared by the County but has been contested by the Contractor as of the "receipt of payment request" date, as defined above, the County shall submit to the Contractor a document setting forth in writing a description of the dispute pertaining to the progress billing, and the County's reason for it's position. Said document shall be submitted to the Contractor as soon as practicable, but not later than 7 calendar days after the "receipt of payment request" date.

Any progress pay estimate which is undisputed and remains unpaid for thirty (30) calendar days, after the "receipt of payment request date" shall accrue interest to the Contractor equivalent to the legal rate set forth in subdivision (a) of Section 685.010 of the California Code of Civil Procedure. The number of days available to the County to make a payment without incurring interest pursuant to this section shall be reduced by the number of days by which the County exceeds the seven-day submittal requirement set forth in the paragraph above.

Pursuant to Public Contract Code Section 20104.50, subsection (e), the progress payment date is the date that funds are encumbered and the payment warrant is issued.

SS 11. PAYMENT FOR EXTRA WORK (FORCE ACCOUNT BASIS):

Extra work to be paid for on a force account basis as directed by the Engineer will be paid for as set forth in Section 9-1.03 of the Standard Specifications. The labor surcharge, equipment rental rates and the right of way delay factors for each classification of equipment are listed in the Department of Transportation publication entitled Labor Surcharge and Equipment Rental Rates. A copy of which is on file at the Office of the Director of Transportation and is hereby incorporated herein in its entirety.

SS 12. FINAL PAYMENT:

Within thirty (30) days after the completion of the work and its acceptance by the Board of Supervisors, Director of Transportation will make a proposed final estimate in writing of the quantities of work done under the contract and the value of such work and will submit such estimate to Contractor. Within thirty (30) days thereafter Contractor shall submit to Director of Transportation his written approval of said proposed final estimate or a written statement of all claims which he has for additional compensation claimed to be due under the contract.

On Contractor's approval or if he files no claims within said period of thirty (30) days, Director of Transportation will issue a final written estimate as submitted to Contractor and County shall pay the entire sum so found to be due after deducting there from all previous payments and all amounts to be kept and all amounts to be retained under the provisions of the contract.

If Contractor within said period of thirty (30) days files claims, Director of Transportation will issue as a semi-final estimate the proposed estimate submitted to Contractor and the County will within thirty (30) days pay the sum found due thereon after deducting all prior payments and all amounts to be kept and retained under the provisions of the contract, Director of Transportation shall then consider and investigate Contractor's claims and shall make such revisions in the said estimate as he may find to be due, and shall then make and issue his final written estimate. County will pay the amount so found due after deducting all previous payments and amount to be retained under the contract.

All prior or partial estimates and payments shall be subjected to correction in the final estimate and payment.

The final estimate shall be conclusive and binding against both parties to the contract on all questions relating to the performance of the contract and the amount of work done there under and compensation therefore, except in the case of gross error. Acceptance of final payment constitutes a release of County by Contractor of all claims relating to the work.

SS 13. DAMAGES:

Contractor acknowledges that failure to perform in strict accordance with the Contract Documents will cause County to suffer special damages in addition to cost of completion of the work in accordance with the provisions of the Contract

Documents. Such special damage could include, but is not limited to, lease and rental cost, additional salaries and overhead, interest during construction, attorney expense, additional engineering, and inspection expense and cost of maintaining or constructing alternate facilities.

SS 14. DOCUMENTS OF CONTRACTOR:

Upon demand, Contractor shall make available to County all documents in its possession relevant to the work accomplished or to be accomplished or any demand or claim of Contractor as to County. This includes copies of documents sent by Contractor or others in its possession. Contractor shall further make available to County conformed copies of all documents submitted to the sureties who executed the Bid Bond, Faithful Performance Bond or Payment Bond for the purpose of obtaining the sureties' signature, including any guarantee or indemnification made to such surety by others for such purpose. Contractor shall maintain in his possession all documents relative to the work for three years after Notice of Completion.

SS 15. RESPONSIBILITY OF CONTRACTOR TO ACT IN AN EMERGENCY:

In case of an emergency which threatens loss or injury to property or life, Contractor shall act without previous instructions as the situation may warrant. Contractor shall notify Director of Transportation immediately thereafter. Any compensation claimed by Contractor, together with substantiating documentation shall be submitted to County via Director of Transportation.

SS 16. LABOR CODE:

Reference is made to Chapter 1, Part 7, Division 2 of the California Labor Code (commencing with Section 1720). By this reference said Chapter 1 is incorporated herein with like effect as if it were here set forth in full. The parties recognize that said Chapter 1 deals, among other things with discrimination, penalties and forfeitures, their disposition and enforcement, wages, working hours, and securing worker's compensation insurance and directly effect the method of prosecution of the work by Contractor and subject it under certain conditions to penalties and forfeitures. Execution of the Agreement by the parties constitutes their agreement to abide by said Chapter 1, their stipulation as to all matters which they are required to stipulate as to by the provisions of said Chapter 1, constitutes Contractor's certification that he is aware of the provisions of said Chapter 1 and will comply with them and further constitutes Contractor's certification as

follows: "I am aware of the provisions of Section 3700 of the California Labor Code which require every employer to be insured against liability for worker's compensation or to undertake self-insurance in accordance with the provisions of that Code, and I will comply with such provisions before commencing the performance of the work of this contract." Contractor and his subcontractors shall comply with the provisions of SS 1777.5 of the Labor Code regarding apprentices.

Contractor shall post at each job site during the course of the work a copy of County's "Determination of Prevailing Wage Rates", copies of said Determination are available from County for this purpose.

SS 17. OBSTRUCTIONS:

Attention is directed to Sections 8-1.10, "Utility and Non-Highway Facilities" and 15, "Existing Highway Facilities" of the Standard Specifications and these Special Provisions.

Add the following to the fourth paragraph of Section 8-1.10, "Utility and Non-Highway Facilities", of the Standard Specifications is amended to read:

In the event that the utility facilities mentioned above are not removed or relocated by the times specified and, if in the opinion of the Engineer, the Contractor's operations are delayed or interfered with by reason of the utility facilities not being removed or relocated by said times, the State will compensate the Contractor for such delays to the extent provided in Section 8-1.09, "Right of Way Delays" of the Standard Specifications, and not otherwise, except as provided in Section 8-1.10, "Utility and Non-Highway Facilities" of the Standard Specifications.

SS 18. INSURANCE - HOLD HARMLESS:

In lieu of the provisions of Section 7-1.12 the following shall apply:

Contractor shall not commence work under this contract until he has obtained the insurance required hereunder and satisfactory proof of said insurance has been submitted to and approved by the County of Riverside.

Contractor shall submit to the County of Riverside a Certificate of Insurance, signed by an authorized representative of the Contractor's insurance provider or agency, which certifies to the County that insurance

coverage is provided in accordance with the requirements of this section. The Certificate of Insurance shall include as attachments the required "Waiver of Subrogation" and "Additional Insured" policy endorsements.

I. Workers Compensation Insurance:

Contractor shall procure and maintain during the life of the contract Worker's Compensation Insurance coverage as prescribed by the laws of the State of California. Policy shall include Employers' Liability including Occupational Disease with limits not less than \$1,000,000 per occurrence. Policy shall be endorsed to provide a Borrowed Servant Endorsement, Alternate Employer Endorsement, or Additional Insured Endorsement naming the County of Riverside, its Director's Officers, Special Districts, Board of Supervisors, employees, agents or representatives as Additional Insureds. Policy shall contain a Waiver of Subrogation in favor of the County of Riverside.

Contractor shall further require each of its subcontractors to procure Worker's Compensation Insurance as required by the State while working on the project and the Contractor shall require the subcontractors to endorse the policy to provide a Borrowed Servant Endorsement, Alternate Employer Endorsement, or Additional Insured Endorsement naming the County of Riverside, its Director's Officers, Special Districts, Board of Supervisors, employees, agents or representatives as Additional Insureds. Policy shall contain a Wavier of Subrogation in favor of the County of Riverside.

II. Comprehensive General Liability Insurance:

Contractor shall take out and maintain during the course of the work General Liability Insurance covering bodily injury and property damage insurance and blanket contractual coverage as to the work and obligations covered hereunder. The amount of the insurance shall be in an amount **not less than \$2,000,000**. The policy may be a combined single limit or split limits, but the amount must be no less than \$2,000,000 per occurrence. The insurance carrier must have a current rating of "A" or better by the A.M. Best Company, a financial size of at least "VIII", and be an admitted carrier in the State of California. Any exceptions must be approved in advance by the County of Riverside Risk Management. Said insurance must contain an endorsement the County of Riverside is named as an additional insured as respects the work covered hereunder and **said insurance must not**



contain, as respects the work covered hereunder, any exclusions as to bodily injury or death or property damage arising out of blasting, explosion, or underground damage to wire, pipes, conduits, mains, sewers, tank tunnels or any similar property - i.e. the so-called "x c u" exclusions. The insurance certificate evidencing such insurance must affirmatively state that the insurance carrier (s) will give Owner 30 days written notice prior to cancellation of the insurance or a reduction in coverage, and that "County of Riverside - its Director's Officers, Special Districts, Board of Supervisors, employees, agents and representatives" are named as Additional Insureds.

In the alternate to naming County of Riverside as additional insured, Contractor may take out and maintain during the course of the work and until acceptance by County, Owner's Protective Liability Insurance in an amount not less than \$2,000,000 covering Riverside County.

### III. Auto Liability:

If Lessee's vehicles or licensed mobile equipment will be on the premises or used in any manner on behalf of the County, then Lessee shall maintain auto liability insurance for all owned, non-owned or hired automobiles in an amount not less than \$1,000,000 per occurrence combined single limit. Policy shall name the "County of Riverside, its Director's Officers, Special Districts, Board of Supervisors, employees, agents, or representatives" as Additional Insureds.

### IV. Hold Harmless:

Contractor shall hold County of Riverside its officers, agent, and employees free and harmless from any liability whatsoever, including wrongful death, based or asserted upon any act or omission of Contractor, its officers, agents, employees or subcontractors relating to or in anywise connected with or arising from the accomplishment of the work, whether or not such acts or omissions were in furtherance of the work required by the Contract Documents and agrees to defend at his expense, including attorney fees, Owner, County of Riverside its officers, agents and employees in any legal action based upon any such alleged acts or omissions.

SS 19. EQUAL EMPLOYMENT OPPORTUNITY:

General:

Contractor shall not discriminate in its recruiting, hiring, promotion, demotion or termination practices on the basis of race, religious creed, color, national origin, ancestry, sex, age or physical handicap in the performance of this Contract shall comply with the provisions of the California Fair Employment Practice Act (commencing with SS 1410 of the Labor Code), the Federal Civil Rights Act of 1964 (P.L. 88-352) and all amendments thereto, Executive Order No. 11246 (30 Federal Register 12319), as amended, and all administrative rules and regulations issued pursuant to said Acts and Order. See particularly 41 Code of Federal Regulation (CFR) Chapter 60.

Contractor shall require each of its subcontractors to comply with the preceding paragraph and shall include in each subcontract language similar to the preceding paragraph.

Contractor shall permit access to its records of employment, employment advertisement, application forms and other pertinent data and records by Owner and any State or Federal agency having jurisdiction for the purpose of investigation to ascertain compliance with this Section.

Owner may assign an affirmative action representative to monitor Contractor and its subcontractor (s) conduct required by this Section, including the right of entry to the construction site for the purpose of obtaining information from persons performing work on the project providing such inspection does not interfere with the progress of the work.

Elsewhere in the Contract Documents specific requirements may be contained covering the same subject matter of this Section. If so, such specific requirements prevail over this Section in case of conflict.

Transactions of \$10,000 or Under:

Contracts and subcontracts not exceeding \$10,000 are exempt from the requirements of this Section. No Contractor or subcontractor shall procure supplies and/or services in less than usual quantities to avoid applicability of this Section. With respect to contracts and subcontractors for indefinite quantities, this Section applies unless the amount required in any one year under such contract will reasonably be expected not to exceed \$10,000.

Transactions in Excess of \$10,000, but Less Than \$50,000:

At Owner's request, Contractor shall certify that it has in effect an affirmative action plan and agrees to comply with all State and Federal laws and regulations regarding Fair Employment Practices. Contractor shall maintain a written copy of its affirmative action plan and furnish Owner a copy of the plan upon request. Owner may require Contractor to complete an Affirmative Action Compliance Report, on a form furnished by Owner, setting forth definite goals during the term of the Contract.

Transactions of \$50,000 or More:

If Contractor has fifty or more employees and a Contract for \$50,000 or more, it shall develop and submit to Owner, within thirty days after award, a written affirmative action compliance program providing in detail specific steps to guarantee equal employment opportunity. Contractor shall include in its affirmative action program a table of job classifications, which table shall include but need not be limited to job titles, duties, and rates of pay.

Contractor shall in each subcontract let to do a portion of the work covered hereunder, where the subcontractor involved has fifty or more employees and the subcontract is for \$50,000 or more, impose in the subcontract the above requirements.

For the purpose of determining the number of employees, the average of the Contractor's or its subcontractor's employees for the twelve month period immediately prior to award, or the total number of employees the Contractor or its subcontractor will have when performing this contract, whichever is higher, shall be used.

Federal Assisted Construction:

If this project is a Federally assisted construction project, then the contract provisions contained in 41 CFR SS 60-1.04 (b) are incorporated herein and the Contractor shall likewise incorporate said provisions in each subcontract entered by Contractor to perform the work. Federally assisted construction is identified as such in the Notice Inviting Bids.

SS . 20. DEPOSIT OF SECURITIES:

In accordance with Public Contract Code Section 22300 and other applicable law, the Contractor may substitute securities for any moneys withheld to ensure performance under the contract.

SS 21. ASSIGNMENT OF CLAIMS:

In submitting a bid on this public works project, or any subcontractor agreeing to supply goods, services, or materials, and entering a contract pursuant thereto, the Contractor and/or subcontractor do offer and agree to assign to the Owner all rights, title, and interest in and to all causes of action it may have under Section 4 of the Clayton Act (15 U.S.C. Section 15) or under the Cartwright Act (Chapter 2 (commencing with Section 16700) of Part 2 of Division 7 of the Business and Professions Code), arising from purchases of goods, services, or materials pursuant to the public works contract or the subcontract. This assignment shall be made and become effective at the time the awarding body tenders final payment to the Contractor, without further acknowledgement by the parties.

SS 22. CLAIMS RESOLUTION:

In accordance with Public Contract Code Section 20104 - 20104.8 and other applicable law, public works claims of \$375,000 or less which arise between the Contractor and the Owner shall be resolved following the statutory procedure unless the Owner has elected to resolve the dispute pursuant to Public Contract Code SS 10240 et seq.

1. All claims shall be submitted in writing and accompanied by substantiating documentation. Claims must be filed on or before the date of final payment unless other notice requirements are provide in the contract. "Claim" means a separate demand by the claimant for (1) a time extension, (2) payment of money or damages arising from work done by or on behalf of the claimant and payment of which is not otherwise expressly provided for or the claimant is not otherwise entitled, or (3) an amount the payment of which is disputed by the Owner.

(a) Claims Under or equal to \$50,000. The Owner shall respond in writing to the claim within 45 days of receipt of the claim, or, the Owner may request, in writing, within 30 days of receipt of the claim, any additional documentation supporting the claim or relating to defenses or claims the Owner may have. If additional information is needed thereafter, it shall be provided upon mutual agreement of the Owner and the claimant. The Owner's written response shall be submitted 15 days after receiving the additional documentation, or within the same period of time taken by the

claimant to produce the additional information, whichever is greater.

- (b) Claims over \$50,000 but less than or equal to \$375,000. The Owner shall respond in writing within 60 days of receipt, or, may request in writing within 30 days of receipt of the claim, any additional documents supporting the claim or relating to defenses or claims the Owner may have against the claimant. If additional information is needed thereafter, it shall be provided pursuant to mutual agreement between the Owner and the claimant. The Owner's response shall be submitted within 30 days after receipt of the further documents, or within the same period of time taken by the claimant to produce the additional information or documents, whichever is greater.
2. If the claimant disputes the Owner's response, or if the Owner fails to respond within the statutory time period, the claimant may so notify the Owner within 15 days of the receipt of the response or the failure to respond, and demand an informal conference to meet and confer for settlement. Upon such demand, the Owner shall schedule a meet and confer conference within 30 days.
  3. If following the meet and confer conference, the claim or any portion thereof remains in dispute, the claimant may file a claim pursuant to Government Code SS 900 et seq. and Government Code SS 910 et seq. For purposes of those provisions, the time within which a claim must be filed shall be tolled from the time the claimant submits the written claim until the time the claim is denied, including any time utilized for the meet and confer conference.
  4. If a civil action is filed to resolve any claim, the provisions of Public Contract Code SS 20104.4 shall be followed, providing for non-binding mediation and judicial arbitration.

SS 23. DUST ABATEMENT:

Dust control shall conform to Section 10, "Dust Control", Section 7-1.01F, "Air Pollution Control", Section 17, "Watering", and Section 18, "Dust Palliative" of the Standard Specifications, Rules no. 401, 402, 403 and 403.1 of the South Coast Air Quality Management District (AQMD), Riverside County Code, Chapter 8.52, "Fugitive Dust Reduction Program For Coachella Valley", all other applicable Federal and State laws, and the requirements set forth herein.

The Contractor is cautioned that failure to control fugitive dust may result in fines being levied by the South Coast Air Quality Management District to both the Contractor and the County of Riverside, as owner. The Contractor shall be fully responsible for payment of all fines pertaining to air pollution control violations, resulting from Contractor's operations related to the construction contract, which may be levied against both the Contractor and the County of Riverside by the AQMD or other regulatory agencies. The Contractor's attention is directed to Section 7-1.01, "Laws to be Observed" of the Standard Specifications. The cost of all fines levied against the County of Riverside will be deducted from any moneys due or which may become due to the Contractor, unless other payment arrangements are made by the Contractor.

Dust control of all of the Contractor's operations is required 24 hours per day, 7 days a week for the duration of the contract, and until the disturbed soil is permanently stabilized. The Contractor shall take every precaution to prevent emissions of fugitive dust from the project site, from locations of stockpiled materials, from unpaved driving surfaces, from haul vehicles, from inactive construction areas, and from all other operations of the Contractor. The Contractor shall plan for and carry out proper and efficient measures to prevent his operations from producing dust in amounts damaging to property or which constitute a public nuisance, or which cause harm to persons living or working in the vicinity of the work. Of particular concern are emissions of PM10 particles, which are fine particulate matter of 10 microns or less and which are associated with sickness and death from respiratory disease.

The Contractor shall furnish and post dust mitigation signs, which shall be, at a minimum, in accordance with the "AQMD Signage Recommendations", attached hereto. Additional copies are available upon request from the Engineer. The sign shall include the Contractor's phone number which shall be maintained on a 24 hour basis. The sign message, size and design, including any deviations from the signage recommendations, shall be approved by the Engineer prior to fabrication.

The Contractor shall respond to complaints by mobilizing equipment and personnel at the construction site within 2 hours of each complaint to control fugitive dust.

Attention is directed to AQMD Rule 403.1, which applies to all contracts within the Coachella Valley Area of Riverside County. That AQMD Rule requires the Contractor to take specified dust control actions when prevailing wind speeds exceed 25 miles per hour. Wind forecasts, AQMD Rules and

other related information are provided by AQMD at 1-800-CUT-SMOG and at [www.aqmd.gov](http://www.aqmd.gov).

Any days on which the Contractor is prevented from working, due to the requirements of AQMD Rules, will be considered as non-working days, in accordance with Section 8-1.06, "Time of Completion" of the Standard Specifications.

The Contractor shall utilize the "Best Available Control Measures" of controlling fugitive dust, as prepared by the AQMD. For projects within the Coachella Valley, the "Reasonably Available Control Measures" may be employed, if effective within the context of the AQMD rules. However, if fugitive dust crosses the project boundary, more effective control measures, including the "Best Available Control Measures" shall be implemented.

A site-specific fugitive dust control plan shall be submitted to the Engineer for review and approval at least 10 days prior to the start of construction. Additionally, for projects outside of the Coachella Valley which meet the criteria for AQMD plan approval, the Contractor shall submit the dust control plan to AQMD for approval. AQMD plan submittal criteria is defined in AQMD Rule 403 as being for projects that will have disturbed surface area in excess of 100 acres, or for projects with a scope of work which requires the movement of more than 10,000 cubic yards of soil on each of any three working days.

A sample plan and other pertinent information is attached, and additional copies are available from the Engineer upon request. The fugitive dust control plan shall include the "Reasonably Available Control Measures" and "Best Available Control Measures" of controlling fugitive dust, as may be appropriate and necessary, including but not limited to watering, application of chemical dust suppressants, wind fencing, covering of haul vehicles, haul vehicle bed-liners, covering or chemically stabilizing stored materials, phased grading, planting of vegetation, the use of a 24 hour environmental observer, and track-out controls at locations where unpaved construction accesses intersect with paved roads. The use of chemical stabilizers, which are approved by all environmental regulatory agencies, and the use of reclaimed water is encouraged. If water is intended as a primary dust control tool, the dust control plan shall provide for at least one 2,000 gallon water truck for every 4 acres of disturbed soil, unless otherwise approved by the Engineer.

If the Construction Engineer determines that the project scope and the forecasted weather conditions are such that the Contractor's work is unlikely to be a source of dust emissions, the Construction Engineer has the authority to waive the requirements for submittal of a dust control plan

and for placement of the dust control signs described herein. However, the Contractors responsibilities for the control of fugitive dust and the other requirements of this section may not be waived.

A completion notice will not be filed, and the final payment will not be made to the Contractor until the areas of disturbed soil on the construction site, including roadway shoulders, are suitably stabilized for long term control of fugitive dust.

The successful Contractor shall attend an AQMD PM10 Dust Control Program training session, and furnish evidence of attendance to the Engineer. Attendance at AQMD training seminars can be scheduled through AQMD at 1-866-861-DUST (1-866-861-3878) or by email to [dustcontrol@aqmd.gov](mailto:dustcontrol@aqmd.gov). Current AQMD certification of previous attendance will be accepted.

At that training session, the successful Contractor will be furnished with the AQMD prepared Rule 403 and Rule 403.1 implementation handbooks, which include the "Best Available Control Measures" and "Reasonably Available Control Measures", and other associated information, including a listing of suggested dust control related devices, materials and chemicals.

The signature of the Contractor on the Proposal constitutes acknowledgement by the Contractor of the dust control requirements established by law and described herein, and the enforceability of those requirements.

When the contract includes a bid item for Dust Abatement, full compensation for conformance with these dust abatement requirements, including labor, equipment, materials, developing water supply and incidentals, shall be paid at the lump sum price for Dust Abatement, and no additional compensation will be allowed therefor.

When the contract does not include a bid item for Dust Abatement, full compensation for conformance with these dust abatement requirements, including labor, equipment, materials, developing water supply and incidentals, shall be considered as included in the various items of work, and no additional compensation will be allowed therefor.



# AQMD RECOMMENDATIONS

November, 2001

Plan holder shall post signage at specified locations on the subject property in accordance with the standards specified below. The exception to the standards is that all letters shall be 4 inches high, with the names and telephone numbers of appropriate contacts and services in bold print, as indicated in the standards. These signs shall also include the SCAQMD toll free complaint line 1-800-CUT-SMOG (1-800-288-7664) and the telephone number for the Environmental Observer. These signs shall be posted within 50 feet of the curb on all four (4) corners of the subject property.

For each Dust Control Plan aggregating less than, or equal to, ten (10) acres:

1. The applicant shall install a sign on such property which is visible to the public that meets the following requirements:
  - (a) Such sign shall measure at least four (4) feet wide by four (4) feet high and conform to the specifications in 1 (a) below.

For each Dust Control Plan aggregating over ten (10) acres:

2. The applicant shall install a sign on such property which is visible to the public that meets the following requirements:
  - (a) Such sign shall measure at least eight (8) feet wide by four (4) feet high and conform to the specifications in 1 (b) below.

## THE SIGN SHALL CONFORM TO THE FOLLOWING REQUIREMENTS:

1. The sign boards shall be constructed with materials capable of withstanding the environment in which they are placed.

(a) For 4' x 4' signs, the District recommends the following:

- I. 3/4" A/C laminated plywood board
- II. Two 4" x 4" posts
- III. The posts should be attached to the edges of the plywood board with at least 2 carriage bolts on each post.
- IV. The front surface of the sign board should be painted in the contrasting color of a white background with black lettering.

(b) For 4' x 8' signs, the District recommends the following:

- I. 1" A/C laminated plywood board
- II. Two 5" x 6" posts
- III. The posts should be attached to the 4' edges of the plywood board with at least 2 carriage bolts on each post.
- IV. The front surface of the sign board should be painted in the contrasting color of a white background with black lettering.

**2. The sign board shall be installed and maintained in a condition such that members of the public can easily view, access, and read the sign at all times until the expiration date of the Dust Control plan.**

(a) For 4' x 4' signs, the District recommends the following:

- I. The lower edge of the sign board should be mounted at least 2' above the existing ground surface to facilitate ease of viewing.
- II. The posts should be set in a hole at least 3' deep with concrete footings to preclude downing by high winds.
- III. On the construction site, the sign should be positioned such that nothing obstructs the public's view from the primary street access point.
- IV. For construction projects that are developed in phases, the sign should be moved to the area that is under active construction.
- V. In situations where all phases of the construction project are completed on a property prior to expiration of the Dust Control Plan, a written request for cancellation of the Dust Control Plan must be submitted to the Engineer.

(b) For 4' x 8' signs, the District recommends the following:

- I. The lower edge of the sign board should be mounted at least 2' above the existing ground surface to facilitate ease of viewing.
- II. The posts should be set in a hole at least 4' deep with concrete footings to preclude downing by high winds.
- III. On the construction site, the sign should be positioned such that nothing obstructs the public's view from the primary street access point.
- IV. For construction projects that are developed in phases, the sign should be moved to the area that is under active construction.
- V. In situations where all phases of the construction project are completed on a property prior to expiration of the Dust Control Plan, a written request for cancellation of the Dust Control Plan must be submitted to the Engineer.

**3. The sign board shall contain the following information:**

- (a) Project Name
- (b) Name of Prime Contractor
- (c) Phone Number of Contractor's Employee Responsible for Dust Control Matters
- (d) County designated phone number (to be provided by the Engineer)
- (e) South Coast Air Quality Management District Phone Number

4. The sign board shall be designed to the following alpha and numeric text dimensions (sign boards written in longhand are unacceptable).

(a) For a permittee subject to the 4' x 4' sign requirement, the District provides the following example: (as modified by the County of Riverside for use on County Public Works projects)

1" UPPERCASE Letters →	PROJECT NAME:		3 ½" Title Case Bold Letters ←
1" UPPERCASE Letters →	CONTRACTOR		3 ½" Title Case Bold Letters ←
1" Title Case Letters →	Contractor's Dust Control Phone #		3" Bold Numbers ←
1" Title Case Letters →	County of Riverside Phone #		3" Bold Numbers ←
1" Title Case Letters →	Phone Number:	<b>SCAQMD 1-800-CUT-SMOG</b>	3 ½" Bold Numbers ←

"Title Case" means the first letter of a word is capitalized and subsequent letters are lower case.

(b) For a permittee subject to the 4' x 8' sign requirement, the District provides the following example: (as modified by the County of Riverside)

2" UPPERCASE Letters	PROJECT NAME:		4" Title Case Bold Letters
2" UPPERCASE Letters	CONTRACTOR		4" Title Case Bold Letters
2" Title Case Letters	Contractor's Dust Control Phone #		4" Bold Numbers
2" Title Case Letters	County of Riverside Phone #	909-	4" Bold Numbers
2" Title Case Letters	Phone Number:	SCAQMD 1-800-CUT-SMOG	4 1/2" Bold Numbers
2" Title Case Letters	COUNTY OF RIVERSIDE TRANSPORTATION DEPARTMENT		

Section 1

Simplified Sample Site Plan

Existing Residential

Distance and location of nearest:

Residence \_\_\_\_\_

Business \_\_\_\_\_

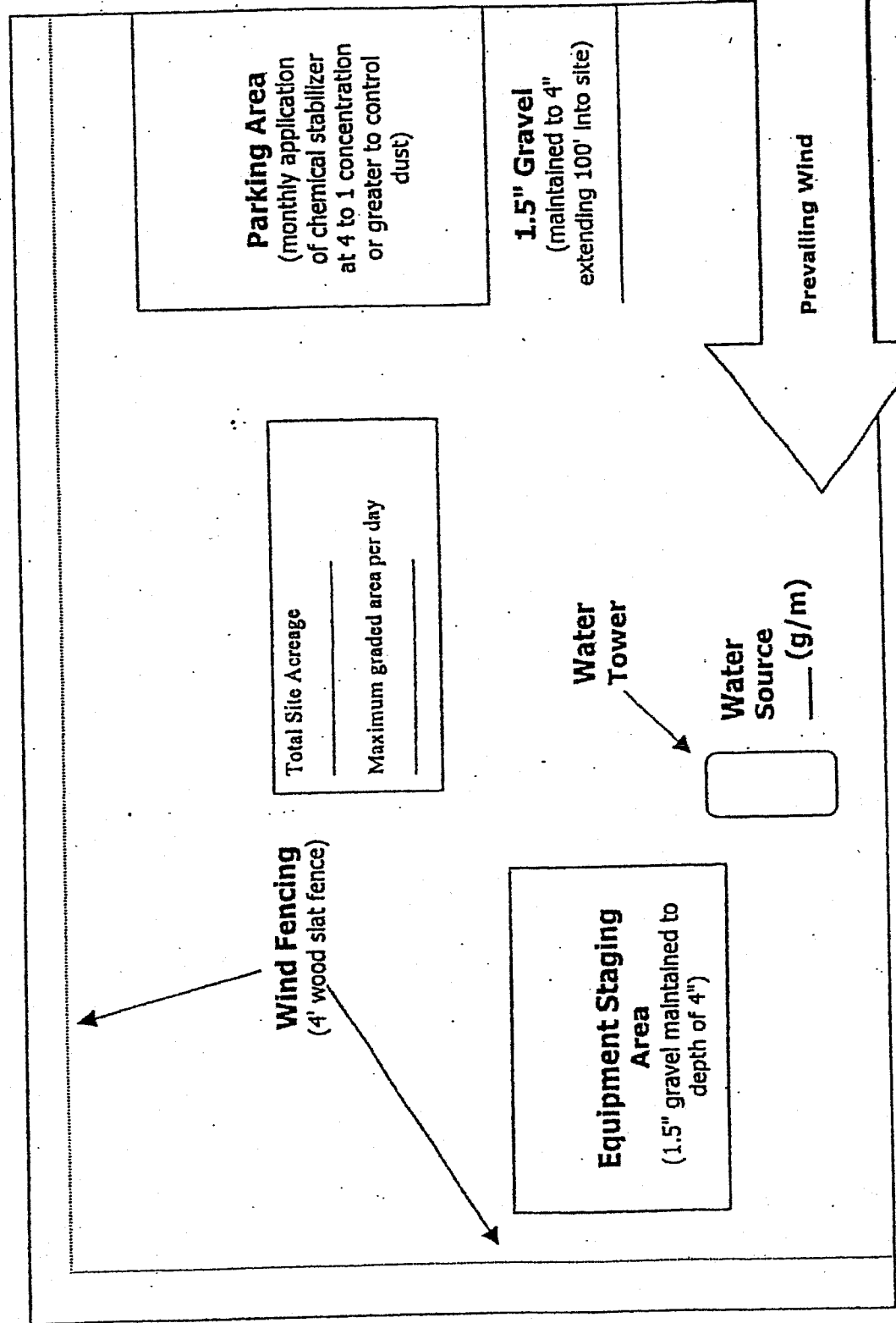
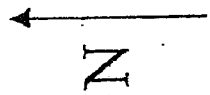

Existing Residential

Site Access

**Parking Area**  
 (monthly application of chemical stabilizer at 4 to 1 concentration or greater to control dust)

**1.5" Gravel**  
 (maintained to 4" extending 100' into site)

Total Site Acreage \_\_\_\_\_

Maximum graded area per day \_\_\_\_\_

Water Tower

Water Source \_\_\_\_\_ (g/m)

Prevailing Wind

Vacant Land

**Equipment Staging Area**  
 (1.5" gravel maintained to depth of 4")

**Wind Fencing**  
 (4' wood slat fence)

Existing Residential

Remember...  
**DUST CONTROL IS REQUIRED 24 HOURS A DAY, 7 DAYS A WEEK, REGARDLESS OF CONSTRUCTION STATUS**

## Plan Review Checklist Clearing/Grubbing/Mass Grading Phase

- If feasible, use grading permit conditions to break the project into phases so that only a portion of the site is disturbed at any given time to ensure control of fugitive dust. This technique is critical for project sites with greater than 100 acres.
  
- Prior to initiating activity, pre-water site through use of portable irrigation lines. At least 72 hours of pre-watering is recommended for each area prior to initiating earth-movement. Require the Applicant to specify water source and available flow rate (g/m).
  
- Water applied continuously to all disturbed portions of the site by means of water truck/water pull as necessary to maintain sufficient visible moisture on the soil surface. For reference, one 2,000 gallon water truck can treat approximately 4 acres of active construction per hour. Also, for cut and fill activities, one 10,000 gallon water pull is estimated to be necessary for each 7,000 cubic yards of daily earth-movement. Multiple 4,000-gallon water trucks may be used in place of one 10,000-gallon water pull. Touch and visual contrast are reasonably good indicators of soil moisture. Surface areas that are dry to the touch and appear lighter-colored require the application of additional water to prevent visible or fugitive dust. Require the Applicant to specify the number of watering vehicles available for dust control during mass grading and during off-hours as well as availability of back-up water trucks if the site experiences dust control problems.
  
- Water towers are necessary for projects with more than 10 acres of active construction. Without a water tower, it can take up to 30 minutes to fill a 2,000 gallon water truck. Also, multiple water towers are necessary for projects that use water pulls as filling one 10,000 gallon water pull can drain a water tower which takes up to 40 minutes to refill.
  
- Wind fencing is necessary between the site and nearby residences or businesses. Off-site upwind fencing and on-site wind fencing for larger projects can also keep blowsand from being deposited onto the site or traveling through the site.
  
- A perimeter watering system consisting of portable irrigation equipment may be an effective mitigation system to protect surrounding residences and businesses. The portable watering system may be used in place of or in conjunction with watering trucks. The local jurisdiction may also be provided access to this equipment.

Remember...

**DUST CONTROL IS REQUIRED 24 HOURS A DAY, 7 DAYS A WEEK,  
REGARDLESS OF CONSTRUCTION STATUS**

Construction site accesses are to be improved with 1.5" gravel maintained to a depth of 4" . at least 20' wide, and extending 100 feet into the site. If the project site is not balanced, a wheel washing system and/or ribbed steel plates should be placed in the roadway before the vehicle enters the graveled area to clean the tires and prevent trackout.

Equipment staging areas are to be treated with 1.5" gravel maintained to a depth of 4".

Employee parking areas are to be covered with 1.5" gravel maintained to a depth of 4" or treated with chemical dust suppressants at a 4 to 1 ratio on at least a monthly basis to prevent fugitive dust.

Chemical dust suppressants are to be mixed at a ratio of 20 to 1 and applied to all disturbed surfaces that are proposed to remain inactive for a period of at least 10 consecutive days. These products are effective in preventing and controlling dust. Recordkeeping is necessary to demonstrate compliance.

All project sites greater than 100 acres shall monitor daily wind speeds and AQMD forecasted wind events (call 1.800.CUT.SMOG, press one for air quality information, and then press five for Coachella Valley wind forecasts). Operators shall maintain these records for review by any local code enforcement officer or AQMD inspector.

An environmental observer whose primary duty is to oversee dust control at the site is to be used for construction projects greater than 100 acres and/or sites with more than 50 acres of active construction. The environmental observer is tasked with monitoring dust abatement measures and authorized to deploy additional water trucks and other dust control actions (i.e., wind fencing, street sweepers, chemical dust suppressants, etc.) as necessary to prevent or control fugitive dust.

Other (specify): \_\_\_\_\_  
\_\_\_\_\_  
\_\_\_\_\_  
\_\_\_\_\_  
\_\_\_\_\_

**Remember...**  
**DUST CONTROL IS REQUIRED 24 HOURS A DAY, 7 DAYS A WEEK,**  
**REGARDLESS OF CONSTRUCTION STATUS**

## Plan Review Checklist Finish Grading Phase

- Water applied continuously to all disturbed portions of the site by means of water truck/water pull as necessary to maintain sufficient visible moisture on the soil surface. For reference, one 2,000 gallon water truck can treat approximately 4 acres of active construction per hour. Also, for cut and fill activities, one 10,000 gallon water pull is estimated to be necessary for each 7,000 cubic yards of daily earth-movement. Multiple 4,000-gallon water trucks may be used in place of a 10,000-gallon water pull. Touch and visual contrast are reasonably good indicators of soil moisture. Surface areas that are dry to the touch and appear lighter-colored require the application of additional water to prevent visible or fugitive dust. Require the Applicant to specify the number of watering vehicles available for dust control during finish grading and during off-hours as well as availability of back-up water trucks if the site experiences dust control problems.
  
- Water towers are necessary for projects with more than 10 acres of active construction. Without a water tower, it can take up to 30 minutes to fill a 2,000 gallon water truck. Also, multiple water towers are necessary for projects that use water pulls as filling one 10,000 gallon water pull can drain a water tower which takes up to 40 minutes to refill.
  
- Wind fencing is necessary between the site and nearby residences or businesses to reduce fugitive dust. Off-site upwind fencing and on-site wind fencing for larger projects can also keep blowsand from being deposited onto the site or traveling through a site.
  
- Chemical dust suppressants are to be applied at a concentration of at least 10 to 1 to finish graded areas once final elevations have been reached. For areas that will remain inactive for longer periods, vegetation can be a cost-effective alternative to chemical stabilization. Wind fencing or other obstructions can keep the stabilized area free from future disturbances.
  
- Construction site access(es) are to be improved with 1.5" gravel maintained to a depth of at least 4" with a minimum width of at least 20', extending 100 feet into the project site.
  
- Equipment staging areas are to be treated with 1.5" gravel maintained to a depth of 4".
  
- Internal roadway networks are to be treated with chemical dust suppressants at a minimum rate of at least 4 to 1 and retreated on a monthly basis once final roadway elevations have been reached.
  
- Employee parking areas are to be treated with chemical dust suppressants at a mix ratio of at least 4 to 1 and retreated on at least a monthly basis or covered with 1.5" gravel maintained to a depth of 4" to prevent fugitive dust.
  
- Other (specify): \_\_\_\_\_  
\_\_\_\_\_  
\_\_\_\_\_

**Remember...**  
**DUST CONTROL IS REQUIRED 24 HOURS A DAY, 7 DAYS A WEEK,**  
**REGARDLESS OF CONSTRUCTION STATUS**



## Plan Review Checklist Construction Phase

- Water applied continuously to all disturbed portions of the site by means of water truck/water pull is necessary to maintain sufficient visible moisture on the soil surface. For reference, one 2,000 gallon water truck can treat approximately 4 acres of active construction per hour. Touch and visual contrast are reasonably good indicators of soil moisture. Surface areas that are dry to the touch and appear lighter-colored require the application of additional water to prevent visible or fugitive dust. Require the Applicant to specify the number of watering vehicles available for dust control during the construction phase and during off-hours as well as availability of back-up water trucks if the site experiences dust control problems.
  
- Wind fencing is necessary between the site and nearby residences or businesses. Off-site upwind fencing and on-site wind fencing for larger projects can also keep blowsand from being deposited onto the site or traveling through the site. Block walls, if part of the final project, can replace wind fencing during the construction phase.
  
- Chemical dust suppressants are to be applied at a concentration of at least 20 to 1 to finish graded areas once final elevations have been reached. For areas that will remain inactive for longer periods, vegetation can be a cost-effective alternative to chemical stabilization. Wind fencing or other obstructions can keep the stabilized area free from future disturbances.
  
- Construction site accesses are to be improved with 1.5" gravel, maintained to a depth of 4", with a width of at least 20', extending 100' into the project site. Paving internal roadways can substitute for gravel.
  
- Internal roadway networks are to be paved as early as feasible in the construction phase. Street sweeping of internal and/or external access roads will likely be required to control entrained road dust.
  
- Employee parking areas are to be treated with chemical dust suppressants at a mix ratio of no less than 4 to 1 and retreated on a monthly basis, or more frequently if fugitive dust is observed. If internal roadway is complete, employees are to be instructed to park on paved roads.
  
- Other (specify): \_\_\_\_\_  
\_\_\_\_\_  
\_\_\_\_\_  
\_\_\_\_\_  
\_\_\_\_\_

**Remember...**  
**DUST CONTROL IS REQUIRED 24 HOURS A DAY, 7 DAYS A WEEK,**  
**REGARDLESS OF CONSTRUCTION STATUS**

## RULE 403 IMPLEMENTATION HANDBOOK

---

### REASONABLY AVAILABLE CONTROL MEASURES

Paragraph (d)(3) of Rule 403 allows activities outside the South Coast Air Basin (see Figure 2-1) to implement reasonably available control measures in lieu of best available control measures. Additionally, as specified by subparagraph (f)(3)(D) of Rule 403, any person seeking approval of a fugitive dust emissions control plan for projects outside the South Coast Air Basin must demonstrate to the satisfaction of the District that the given activity is employing all reasonably available fugitive dust control measures.

The District has prepared the attached listing of reasonably available fugitive dust control measures for a variety of source categories. This list is based on the U.S. Environmental Protection Agency's reference document entitled, "Control of Open Fugitive Dust Sources," Midwest Research Institute, September 1988.

The District encourages the use of those dust control measures that minimize the use of potable water. When water is needed, reclaimed water should be utilized to the greatest extent feasible.

# RULE 403 IMPLEMENTATION HANDBOOK

## REASONABLY AVAILABLE CONTROL MEASURES

The left column contains a listing of the sources of fugitive dust which are intended for emission control under District Rule 403 and a listing of control measures and high-wind measures. The right column contains a description of the reasonably available fugitive dust control measures for each of the sources.

Source: (1) Land Clearing/Earth-Moving

### CONTROL MEASURES

### DESCRIPTION

(A) Watering

- (1) Application of water by means of trucks, hoses and/or sprinklers prior to conducting any land clearing. This will increase the moisture content of the soils; thereby increasing its stability.
- (2) Pre-application of water to depths of proposed cuts.
- (3) Once the land clearing/earth moving activities are complete, a second application of water can generate a thin crust that stabilizes the disturbed surface area provided that it is not disturbed. (Security fencing can be used to prevent unwanted future disturbances of sites where a surface crust has been created).

(B) Chemical stabilizers

- (1) Only effective in areas which are not subject to daily disturbances.
- (2) Vendors can supply information on product application and required concentrations to meet the specifications established by the Rule.

(C) Wind fencing

- (1) Three- to five-foot barriers with 50% or less porosity located adjacent to roadways or urban areas can be effective in reducing the amount of windblown material leaving a site.
- (2) Would likely be used in conjunction with other measures (e.g., watering, chemical stabilization, etc.) to ensure that visible emissions do not cross a property line.

(D) Cover haul vehicles

- (1) Entire surface area of hauled earth should be covered once vehicle is full.

(E) Bedliners in haul vehicles

- (1) When feasible, use in bottom-dumping haul vehicles.

### HIGH WIND MEASURE

- (a) Cease all active operations; or
- (b) Apply water within 15 minutes to any soil surface which is being moved or otherwise disturbed.

Source: (2) Unpaved Roads

CONTROL MEASURES

(F) Paving  
(G) Chemical stabilization

(H) Watering

(I) Reduce speed limits

(J) Reduce vehicular trips

(K) Gravel

DESCRIPTION

- (1) Requires street sweeping/cleaning if subject to material accumulation.
- (1) Vendors can supply information as to application methods and concentrations to meet the specifications established by the Rule
- (2) Not recommended for high volume or heavy equipment traffic use.
- (1) In sufficient quantities to keep surface moist.
- (2) Required application frequency will vary according to soil type, weather conditions, and vehicular use.
- (1) 15 mile per hour maximum. May need to be used in conjunction with watering or chemical stabilization to prevent visible emissions from crossing the property line.
- (1) Access restriction or redirecting traffic to reduce vehicle trips by a minimum of 60 percent.
- (1) Gravel maintained to a depth of four inches can be an effective measure.
- (2) Should only be used in areas where paving, chemical stabilization or frequent watering is not feasible.

HIGH WIND MEASURE

- (c) Apply a chemical stabilizer (to meet the specifications established by the Rule) prior to wind events; or
- (d) Apply water once each hour; or
- (e) Stop all vehicular traffic.

# RULE 403 IMPLEMENTATION HANDBOOK

Source: (3) Storage Piles

## CONTROL MEASURES

### DESCRIPTION

- |  |  |
|--|--|
| (L) Wind sheltering                      | (1) Enclose in silos.<br>(2) Install three-sided barriers equal to height of material, with no more than 50 percent porosity.  |
| (M) Watering                             | (1) Application methods include: spray bars, hoses and water trucks.<br>(2) Frequency of application will vary on site-specific conditions.  |
| (N) Chemical stabilizers                 | (1) Best for use on storage piles subject to infrequent disturbances.  |
| (O) Altering load-in/load-out procedures | (1) Confine load-in/load-out procedures to leeward (downwind) side of the material.<br>(2) May need to be used in conjunction with wind sheltering to prevent visible emissions from crossing the property line. |
| (P) Coverings                            | (1) Tarps, plastic, or other material can be used as a temporary covering.<br>(2) When used, these should be anchored to prevent wind from removing coverings.   |

## HIGH WIND MEASURE

- (f) Apply chemical stabilizers (to meet the specifications established by the Rule) prior to wind events; or  
(g) Apply water once per hour; or  
(h) Install temporary covers.

Source: (4) Paved Road Track-Out

**CONTROL MEASURES**

- (Q) Chemical stabilization
- (R) Sweep/clean roadways
- (S) Cover haul vehicles
- (T) Bedliners in haul vehicles
- (U) Site access improvement

**DESCRIPTION**

- (1) Most effective when used on areas where active operations have ceased.
- (2) Vendors can supply information on methods for application and required concentrations.
- (1) Either sweeping or water flushing may be used.
- (1) Entire surface area should be covered once vehicle is full.
- (1) When feasible, use in bottom dumping vehicles.
- (1) Pave internal roadway system.
- (2) Most important segment, last 100 yards from the connection with paved public roads

**HIGH WIND MEASURE**

- (i) Cover all haul vehicles; and
- (i) Clean streets with water flushing, unless prohibited by the Regional Water Quality Control Board.

# RULE 403 IMPLEMENTATION HANDBOOK

---

Source: (5) Disturbed Surface Areas/ Inactive Construction Sites

## CONTROL MEASURES

### DESCRIPTION

- (Q) Chemical stabilization
  - (1) Most effective when used on areas where active operations have ceased.
  - (2) Vendors can supply information on methods for application and required concentrations.
- (R) Watering
  - (1) Requires frequent applications unless a surface crust can be developed.
- (S) Wind fencing
  - (1) Three- to five-foot barriers with 50% or less porosity adjacent to roadways or urban areas can be effective in reducing the amount of wind blown material leaving a site.
- (T) Vegetation
  - (1) Establish as quickly as possible when active operations have ceased.
  - (2) Use of drought tolerant, native vegetation is encouraged.

## HIGH WIND MEASURES

- (k) Apply chemical stabilizers (to meet the specifications established by the Rule); or
- (l) Apply water to all disturbed surface areas 3 times per day.

## BEST AVAILABLE CONTROL MEASURES

Rule 403, paragraph (d)(2) requires active operations [defined in Rule 403, paragraph (c)(1)] within the South Coast Air Basin (see Figure 2-1) to implement at least one best available control measure for each fugitive dust source type on site. Additionally, as specified by subparagraph (f)(3)(D) of Rule 403, any person seeking approval of a fugitive dust emissions control plan for projects within the South Coast Air Basin must demonstrate to the satisfaction of the AQMD that the given activity is employing all best available fugitive dust control measures.

The AQMD has prepared the attached listing of best available fugitive dust control measures for a variety of source categories. This list is based on the U.S. Environmental Protection Agency's reference document entitled, "Fugitive Dust Background Document and Technical Information Document for Best Available Control Measures," Office of Air and Radiation, September 1992.

The AQMD encourages the use of those dust control measures that minimize the use of potable water. When water is needed, reclaimed water should be utilized to the greatest extent feasible.



# RULE 403 IMPLEMENTATION HANDBOOK

## BEST AVAILABLE CONTROL MEASURES

The left column contains a listing of the sources of fugitive dust which are intended for emission control under District Rule 403, and a listing of control measures and high-wind measures. The right column contains a description of the best available fugitive dust control measures for each of the sources.

Source: (1) Land Clearing/Earth-Moving

### CONTROL MEASURES

### DESCRIPTION

- |                                |   |
|--------------------------------|---|
| (A) Watering (pre-grading)     | (1) Application of water by means of trucks, hoses and/or sprinklers prior to conducting any land clearing. This will increase the moisture content of the soils; thereby increasing its stability.   |
| (A-1) Watering (post-grading)  | (2) Pre-application of water to depths of proposed cuts.  |
| (A-2) Pre-grading planning     | (1) In active earth-moving areas water should be applied at sufficient frequency and quantity to prevent visible emissions from extending more than 100 feet from the point of origin.  |
| (B) Chemical stabilizers       | (1) Grade each phase separately, timed to coincide with construction phase; or<br>(2) Grade entire project, but apply chemical stabilizers or ground cover to graded areas where construction phase begins more than 60 days after grading phase ends.    |
| (C) Wind fencing               | (1) Only effective in areas which are not subject to daily disturbances.<br>(2) Vendors can supply information on product application and required concentrations to meet the specifications established by the Rule.                                     |
| (D) Cover haul vehicles        | (1) Three- to five-foot barriers with 50% or less porosity located adjacent to roadways or urban areas can be effective in reducing the amount of windblown material leaving a site. Must be implemented in conjunction with either measure (A-1) or (B). |
| (E) Bedliners in haul vehicles | (1) Entire surface area of hauled earth should be covered once vehicle is full.<br>(1) When feasible, use in bottom-dumping haul vehicles.  |

### HIGH WIND MEASURE

- (a) Cease all active operations; or  
(b) Apply water within 15 minutes to any soil surface which is being moved or otherwise disturbed.

# RULE 403 IMPLEMENTATION HANDBOOK

Source: (2) Unpaved Roads

## CONTROL MEASURES

(F) Paving

(G) Chemical stabilization

(H) Watering

(I) Reduce speed limits

(J) Reduce vehicular trips

(K) Gravel

## DESCRIPTION

- (1) Requires street sweeping/cleaning if subject to material accumulation.
- (1) Vendors can supply information as to application methods and concentrations to meet the specifications established by the Rule
- (2) Not recommended for high volume or heavy equipment traffic use.
- (1) In sufficient quantities to keep surface moist.
- (2) Required application frequency will vary according to soil type, weather conditions, and vehicular use.
- (1) 15 mile per hour maximum. May need to be used in conjunction with watering or chemical stabilization to prevent visible emissions from crossing the property line.
- (1) Access restriction or redirecting traffic to reduce vehicle trips by a minimum of 60 percent.
- (1) Gravel maintained to a depth of four inches can be an effective measure.
- (2) Should only be used in areas where paving, chemical stabilization or frequent watering is not feasible.

## HIGH WIND MEASURE

- (a) Apply a chemical stabilizer (to meet the specifications established by the Rule ) prior to wind events; or
- (b) Apply water once each hour; or
- (c) Stop all vehicular traffic.

# RULE 403 IMPLEMENTATION HANDBOOK

Source: (3) Storage Piles

## CONTROL MEASURES

### DESCRIPTION

- |  |  |
|--|--|
| (L) Wind sheltering                      | (1) Enclose in silos.<br>(2) Install three-sided barriers equal to height of material, with no more than 50 percent porosity.                                  |
| (M) Watering                             | (1) Application methods include: spray bars, hoses and water trucks.<br>(2) Frequency of application will vary on site-specific conditions.                    |
| (N) Chemical stabilizers                 | (1) Best for use on storage piles subject to infrequent disturbances.  |
| (O) Altering load-in/load-out procedures | (1) Confine load-in/load-out procedures to leeward (downwind) side of the material.<br>Must be used in conjunction with either measure (L), (M), (N), or (P).  |
| (P) Coverings                            | (1) Tarps, plastic, or other material can be used as a temporary covering.<br>(2) When used, these should be anchored to prevent wind from removing coverings. |

## HIGH WIND MEASURE

- (a) Apply chemical stabilizers (to meet the specifications established by the Rule) prior to wind events; or  
(b) Apply water once per hour; or  
(c) Install temporary covers.

**RULE 403 IMPLEMENTATION HANDBOOK**

---

Source: (4) Paved Road Track-Out

**CONTROL MEASURES**

Compliance with District Rule 403.

**DESCRIPTION**

Paragraph (d)(5).

# RULE 403 IMPLEMENTATION HANDBOOK

---

Source: (5) Disturbed Surface Areas/ Inactive Construction Sites

## CONTROL MEASURES

### DESCRIPTION

- (Q) Chemical stabilization
  - (1) Most effective when used on areas where active operations have ceased.
  - (2) Vendors can supply information on methods for application and required concentrations.
- (R) Watering
  - (1) Requires frequent applications unless a surface crust can be developed.
- (S) Wind fencing
  - (1) Three- to five-foot barriers with 50% or less porosity adjacent to roadways or urban areas can be effective in reducing the amount of wind blown material leaving a site. Must be used in conjunction with either measure (Q), (R), or (T).
- (T) Vegetation
  - (1) Establish as quickly as possible when active operations have ceased.\*

## HIGH WIND MEASURES

- (a) Apply chemical stabilizers (to meet the specifications established by the Rule); or
- (b) Apply water to all disturbed surface areas 3 times per day.

---

\* Use of drought tolerant, native vegetation is encouraged.

TABLE 1

BEST [REASONABLY]\* AVAILABLE CONTROL MEASURES FOR HIGH WIND CONDITIONS

<b>FUGITIVE DUST SOURCE CATEGORY</b>	<b><u>CONTROL MEASURES</u></b>
<b>Earth-moving</b>	(1A) Cease all active operations; OR (2A) Apply water to soil not more than 15 minutes prior to moving such soil.
<b>Disturbed surface areas</b>	(0B) On the last day of active operations prior to a weekend, holiday, or any other period when active operations will not occur for not more than four consecutive days: apply water with a mixture of chemical stabilizer diluted to not less than 1/20 of the concentration required to maintain a stabilized surface for a period of six months; OR (1B) Apply chemical stabilizers prior to wind event; OR (2B) Apply water to all unstabilized disturbed areas 3 times per day. If there is any evidence of wind driven fugitive dust, watering frequency is increased to a minimum of four times per day; OR (3B) Take the actions specified in Table 2, Item (3c); OR (4B) Utilize any combination of control actions (1B), (2B), and (3B) such that, in total, these actions apply to all disturbed surface areas.
<b>Unpaved roads</b>	(1C) Apply chemical stabilizers prior to wind event; OR (2C) Apply water twice [once] per hour during active operation; OR (3C) Stop all vehicular traffic.
<b>Open storage piles</b>	(1D) Apply water twice [once] per hour; OR (2D) Install temporary coverings.
<b>Paved road track-out</b>	(1E) Cover all haul vehicles; OR (2E) Comply with the vehicle freeboard requirements of Section 23114 of the California Vehicle Code for both public and private roads.
<b>All Categories</b>	(1F) Any other control measures approved by the Executive Officer and the U.S. EPA as equivalent to the methods specified in Table 1 may be used.

\* Measures in [brackets] are reasonably available control measures and only apply to sources not within the South Coast Air Basin.

January 1999

**TABLE 2**  
**DUST CONTROL ACTIONS FOR EXEMPTION FROM PARAGRAPH (d)(4)\***

<u>FUGITIVE DUST SOURCE CATEGORY</u>	<u>CONTROL ACTIONS</u>
<p><b>Earth-moving (except construction cutting and filling areas, and mining operations)</b></p>	<p>(1a) Maintain soil moisture content at a minimum of 12 percent, as determined by ASTM method D-2216, or other equivalent method approved by the Executive Officer, the California Air Resources Board, and the U.S. EPA. Two soil moisture evaluations must be conducted during the first three hours of active operations during a calendar day, and two such evaluations each subsequent four-hour period of active operations;  OR  (1a-1) For any earth-moving which is more than 100 feet from all property lines, conduct watering as necessary to prevent visible dust emissions from exceeding 100 feet in length in any direction.</p>
<p><b>Earth-moving:  Construction fill areas:</b></p>	<p>(1b) Maintain soil moisture content at a minimum of 12 percent, as determined by ASTM method D-2216, or other equivalent method approved by the Executive Officer, the California Air Resources Board, and the U.S. EPA. For areas which have an optimum moisture content for compaction of less than 12 percent, as determined by ASTM Method 1557 or other equivalent method approved by the Executive Officer and the California Air Resources Board and the U.S. EPA, complete the compaction process as expeditiously as possible after achieving at least 70 percent of the optimum soil moisture content. Two soil moisture evaluations must be conducted during the first three hours of active operations during a calendar day, and two such evaluations during each subsequent four-hour period of active operations.</p>

\* Measures in [brackets] are reasonably available control measures and only apply to sources not within the South Coast Air Basin.

TABLE 2 (Continued)

<b>FUGITIVE DUST SOURCE CATEGORY</b>	<b>CONTROL ACTIONS</b>
<b>Earth-moving: Construction cut areas and mining operations:</b>	(1c) Conduct watering as necessary to prevent visible emissions from extending more than 100 feet beyond the active cut or mining area unless the area is inaccessible to watering vehicles due to slope conditions or other safety factors.
<b>Disturbed surface areas (except completed grading areas)</b>	(2a/b) Apply dust suppression in sufficient quantity and frequency to maintain a stabilized surface. Any areas which cannot be stabilized, as evidenced by wind driven fugitive dust must have an application of water at least twice per day to at least 80 [70] percent of the unstabilized area.
<b>Disturbed surface areas: Completed grading areas</b>	(2c) Apply chemical stabilizers within five working days of grading completion; OR  (2d) Take actions (3a) or (3c) specified for inactive disturbed surface areas.
<b>Inactive disturbed surface areas</b>	(3a) Apply water to at least 80 [70] percent of all inactive disturbed surface areas on a daily basis when there is evidence of wind driven fugitive dust, excluding any areas which are inaccessible to watering vehicles due to excessive slope or other safety conditions; OR  (3b) Apply dust suppressants in sufficient quantity and frequency to maintain a stabilized surface; OR  (3c) Establish a vegetative ground cover within 21 [30] days after active operations have ceased. Ground cover must be of sufficient density to expose less than 30 percent of unstabilized ground within 90 days of planting, and at all times thereafter; OR  (3d) Utilize any combination of control actions (3a), (3b), and (3c) such that, in total, these actions apply to all inactive disturbed surface areas.

\* Measures in [brackets] are reasonably available control measures and only apply to sources not within the South Coast Air Basin.

January 1999



TABLE 2 (Continued)\*

<u>FUGITIVE DUST SOURCE CATEGORY</u>	<u>CONTROL ACTIONS</u>
<b>Unpaved Roads</b>	(4a) Water all roads used for any vehicular traffic at least once per every two hours of active operations [3 times per normal 8 hour work day]; OR (4b) Water all roads used for any vehicular traffic once daily and restrict vehicle speeds to 15 miles per-hour; OR (4c) Apply a chemical stabilizer to all unpaved road surfaces in sufficient quantity and frequency to maintain a stabilized surface.
<b>Open storage piles</b>	(5a) Apply chemical stabilizers; OR (5b) Apply water to at least 80 [70] percent of the surface area of all open storage piles on a daily basis when there is evidence of wind driven fugitive dust; OR (5c) Install temporary coverings; OR (5d) Install a three-sided enclosure with walls with no more than 50 percent porosity which extend, at a minimum, to the top of the pile.
<b><u>All Categories</u></b>	(6a) Any other control measures approved by the Executive Officer and the U.S. EPA as equivalent to the methods specified in Table 2 may be used.

\* Measures in [brackets] are reasonably available control measures and only apply to sources not within the South Coast Air Basin.

**TABLE 3**  
**TRACK-OUT CONTROL OPTIONS**  
**PARAGRAPH (d)(5)(B)**

**CONTROL OPTIONS**

(1)	Pave or apply chemical stabilization at sufficient concentration and frequency to maintain a stabilized surface starting from the point of intersection with the public paved surface, and extending for a centerline distance of at least 100 feet and a width of at least 20 feet.
(2)	Pave from the point of intersection with the public paved road surface, and extending for a centerline distance of at least 25 feet and a width of at least 20 feet, and install a track-out control device immediately adjacent to the paved surface such that exiting vehicles do not travel on any unpaved road surface after passing through the track-out control device.
(3)	Any other control measures approved by the Executive Officer and the U.S. EPA as equivalent to the methods specified in Table 3 may be used.

January 1999

**COUNTYWIDE TRAFFIC SIGNAL  
BATTERY BACKUP SYSTEM AND  
LED MODULE IMPROVEMENT PROJECT  
AT VARIOUS LOCATIONS  
PHASE-3**

**PROJECT NO. B9-0996**

**SPECIAL PROVISIONS**

**DESCRIPTION:**

In general, this project consists of improving existing traffic signals with new traffic signal LED modules (Red and Green), and battery backup system (BBS) throughout the Riverside County, minor concrete sidewalk/maintenance pad and associated improvements as may be required.

**SPECIFICATIONS:**

This project shall conform to the requirements of the May 2006 edition of the Standard Specifications and Standard Plans as issued by the State of California Department of Transportation.

Amendments to May 2006 Standard Specifications, updated June 20, 2012, are incorporated herein and can be found on the County of Riverside website during the Bid Period.

**DISPOSAL OF EXCESS EXCAVATION OR MATERIALS:**

Excess earth excavation, pavement grindings and other excess materials resulting from construction operations shall be disposed of by the Contractor outside of the highway right of way, as provided in Section 7-1.13 of the Standard Specifications.

The second paragraph of Section 7-1.13 of the Standard Specifications is modified to read as follows:

When any material is to be disposed of outside the highway right of way, and the County of Riverside has not made arrangements for the disposal of such material, the Contractor shall first obtain written authorization from the property owner on whose property the disposal is to be made, and obtain all required permits from the jurisdictional agency(s) for said work, and he shall file with the Engineer said authorization or a certified copy thereof together with a written release from the property owner absolving the County of Riverside from any and all responsibility in connection with the disposal of material on said property. If the disposal of materials is to be made at an established disposal facility that is available for public use, the Contractor shall retain all authorizations and receipts from said disposal facility and shall provide copies to the Engineer upon request.

Full compensation for all costs involved in disposing of materials as specified in this section, including all costs of hauling, shall be considered as included in the various contract items of work and no additional compensation will be allowed therefor.

**RECORD DRAWINGS:**

The Contractor shall keep one clean set of bond originals to note any changes which take place during construction. These changes to the original specifications shall be noted at the appropriate locations with the appropriate changes indicated in red pencil or ink. The job will not be finalized by the Engineer until these record drawings have been completed to the satisfaction of the Engineer. The changes shall be noted on the specification book as the changes occur and shall be submitted to the Resident Engineer, and become the property of the County at conclusion of the project.

Full compensation for conforming to the requirements of this article shall be considered to be included in other items of work and no additional compensation will be allowed therefore.

**LIQUIDATED DAMAGES:**

The Contractor shall diligently prosecute the work to completion before the expiration of **35** working days from the date stated in the "Notice to Proceed". The Contractor shall pay to the County of Riverside the sum of **\$1,900.00** per day, for each and every calendar day's delay in finishing the work in excess of the number of working days prescribed above.

## ITEMS OF WORK

### TRAFFIC CONTROL SYSTEM:

Contractor shall prepare construction staging and traffic control plans for review and approval by the Transportation Department.

Proposed plans shall be submitted by the Contractor for review and approval by the Transportation Department at least two weeks prior to the start of construction. The construction staging and traffic control plans shall be prepared, signed and stamped by a Civil Engineer or Traffic Engineer who is registered as such in the State of California, unless otherwise specifically allowed by the Engineer. The Contractor shall revise and implement the plans as directed by the Construction Engineer. Construction shall not begin until the Engineer provides Contractor with County approval of the plans.

Construction staging and traffic control plans shall be in accordance with the appropriate standards and specifications for construction staging, detour roads, traffic control, including the State of California Highway Design Manual, the manual on Uniform Traffic Control Devices 2012 Edition, the corresponding California Supplement, and subsequent modifications as adopted by the State of California Department of Transportation, Standard Plans and Standard Specifications, and the Work Area Traffic Control Handbook (WATCH), as published by Building News, Inc. Any requests for deviation from the established design standards or specifications are to be submitted to the Construction Engineer for review and approval prior to submission of the required plans.

With regard to the preparation and implementation of the plans, attention is especially directed to Sections 7-1.06, 7-1.08, 7-1.09, 7-1.11, 7-1.12 and Section 12 of the State of California Standard Specifications. Section 12-2.02 of the Standard Specifications is deleted.

Maintaining traffic shall conform to the provisions in 7-1.02 "Load Limitations", 7-1.06 "Safety and Health Provisions", 7-1.08 "Public Convenience", 7-1.09 "Public Safety", and 12-3.04 "Portable Delineators" of the Standard Specifications, the Manual on Uniform Traffic Control Devices 2012 Edition, the corresponding California Supplement, and subsequent modifications as adopted by the State of California Department of Transportation, the Section of these contract documents entitled "Insurance - Hold Harmless", and these Special Provisions.

All existing traffic control signs and street name signs shall be maintained in visible locations as directed by the Engineer.

No detours will be provided, unless specifically allowed herein. The Contractor will be required to conduct his operations in such a manner that traffic will be permitted to pass through the work area with as little delay as possible.

All warning lights, signs, flares, barricades and other facilities for the sole convenience and direction of public traffic shall be furnished and maintained by the Contractor. All traffic control devices shall conform to and be placed in accordance with the Manual on Uniform Traffic Control Devices 2012 Edition, the corresponding California Supplement, and subsequent modifications as adopted by the State of California Department of Transportation.

All construction signs shall be either covered or removed when not required by the nature of the work or if no present hazard to the motorist exists.

The Contractor shall notify the appropriate regional notification center for operators of subsurface installations at least 2 working days, but not more than 14 calendar days, prior to commencing excavation for construction area sign posts. The regional notification centers include, but not limited to, the following:

Notification Center	Telephone Number
Underground Service Alert-Southern California (USA)	1-800-422-4133 1-800-227-2600 or 811

Excavations required to install construction area signs shall be performed by hand methods without the use of power equipment, except that power equipment may be used if it is determined there are no utility facilities in the area of the proposed post holes.

No payment for extra work will be allowed for work performed as specified in Section 12-2.02 (Flagging Costs) of the Standard Specifications. Flagging costs will be borne entirely by the Contractor.

Dust control shall conform to the provision of Section 10 of the Standard Specifications except that no extra work will be allowed when the Engineer orders the application of water for the purpose of controlling dust caused by public traffic as provided for in the last paragraph of Section 10.

The Contractor shall be responsible to distribute an information letter pertaining to the planned work to all affected residences and businesses, at least one week prior to commencing work adjacent to those residences and businesses. It shall be the responsibility of the Contractor to design the information letter, obtain design approval from the Engineer, print sufficient copies, and distribute the letter. The Transportation Department logo shall be included on the letter. A computer file of the logo may be obtained from the Engineer in .WPG, .DXF, .DGN or .DWG format. The letter shall be similar to the sample provided by the Engineer, and shall include a project description, the scope of work, the anticipated construction schedule, and other information as appropriate.

The Contractor shall post temporary no parking signs on affected streets 24 hours prior to work on those streets. The temporary no parking signs shall state the anticipated dates and hours of work on those streets.

Payment - Full compensation, except as otherwise provided herein, for conforming to the requirements of this article, including furnishing, installing and maintaining all traffic control devices shown on the construction staging and traffic control plans and conforming to the requirement of Graffiti Removal provision of these Special Provisions, shall be paid for on a lump sum basis, and no additional compensation will be allowed therefor.

## **GRAFFITI REMOVAL AND CLEANING:**

The Contractor shall remove existing graffiti within the project limits and any new graffiti produced during the construction period of the project.

Contractor shall submit a method of graffiti removal plan to the Engineer for approval. Sand blasting will not be allowed. Methods may include but not limited to power washing, solvent washing, and painting over graffiti, as appropriate for the surface to be cleaned.

All graffiti shall be completely removed or obliterated and the area feathered out to hide any imperfections.

Graffiti shall be removed from battery backup system covers and directly connected components.

Graffiti to be removed may include, but shall not be limited to: electrical components, covers, signs, wood, metal, plastic, decals, gum, markers, crayons, strings, wires, and tapes of any kind on an as needed basis.

All painting over graffiti must be done with exact color matches, so as not to show any blocking or shadowing of colors. Painting over graffiti is the preferred option on previously painted surfaces, and where solvents are unsuccessful at removing graffiti.”

Paint shall be exact color match. Paint types may include oil base, water base and enamels as approved by the Engineer. Graffiti cover-up by paint will be allowed with appropriate type of paint at locations where graffiti cannot be removed only upon direction by the Engineer. All paint applications shall adhere to the manufacture’s recommendations. All material and solutions shall be safe and biodegradable and approved by the Engineer.

Regional Water Quality Control Board (RWQCB) and Air Quality Management District (AQMD) regulations, as well as all NPDES required best management practices shall be complied with and followed.

The Contractor shall so conduct his operation as to cause the least possible obstruction and inconvenience to public traffic. The Contractor shall provide, erect and maintain barricades, lights, danger signals, and warning signs as deemed appropriate by the Engineer.

The Contractor shall respond and provide manpower for any urgent graffiti removal and cleaning notifications within two (2) working days.

### ***Method of Payment:***

Full compensation for conformance with these Graffiti Removal and Cleaning requirements, including labor, equipment, materials, necessary traffic control, and incidentals, shall be considered as included in the lump sum price paid for Traffic Control System, and no additional compensation will be allowed therefor.

## **MAINTAINING TRAFFIC:**

Maintaining traffic shall conform to the provisions in Section 7-1.08, "Public Convenience", Section 7-1.09, "Public Safety" and Section 12, "Construction Area Traffic Control Devices" of the Standard Specifications and "Public Safety" of these Special Provisions.

Closure is defined as the closure of a traffic lane or lanes, including shoulder, ramp or connector lanes, within a single traffic control system.

Closure shall conform to the provisions in "Traffic Control System" of these Special Provisions.

Local authorities shall be notified at least five (5) business days before work begins. The Contractor shall cooperate with local authorities to handle traffic through the work area and shall make arrangements to keep the work area clear of parked vehicles.

Personal vehicles of the Contractor's employees shall not be parked on the traveled way or shoulders including sections closed to public traffic.

When work vehicles or equipment are parked on the shoulder within six (6) feet of a traffic lane, the shoulder area shall be closed.

When work vehicles or equipment are parked on the shoulder within six (6) feet of a traffic lane, the shoulder area shall be closed with fluorescent orange traffic cones or portable delineators placed on a taper in advance of the parked vehicles or equipment and along the edge of the pavement at 25-foot intervals to a point not less than 25 feet past the last vehicle or piece of equipment. A minimum of 9 traffic cones or portable delineators shall be used for the taper. A W20-1 (ROAD WORK AHEAD) or W21-5b (RIGHT/LEFT SHOULDER CLOSED AHEAD) or C24 (CA) (SHOULDER WORK AHEAD) sign shall be mounted on a crashworthy portable sign support with flags. The sign shall be placed where designated by the Engineer. The sign shall be a minimum of 48" x 48" in size. The Contractor shall immediately restore to the original position and location a traffic cone or delineator that is displaced or overturned, during the progress of work.

If minor deviations from the lane requirement chart are required, a written request shall be submitted to the Engineer at least 15 days before the proposed date of the closure. The Engineer may approve the deviations if there is no significant increase in the cost to the County and if the work can be expedited and better serve the public traffic.

Designated County legal holidays are January 1<sup>st</sup>, the third Monday in January, February 12<sup>th</sup>, the third Monday in February, the last Monday in May, July 4<sup>th</sup>, the first Monday in September, the second Monday in October, November 11<sup>th</sup>, Thanksgiving Day, the Friday following Thanksgiving Day, December 24<sup>th</sup> and 31<sup>st</sup> when they fall on Monday, December 25<sup>th</sup>, December 26<sup>th</sup> and January 2<sup>nd</sup> when they fall on Friday, When a designated legal holiday falls on a Sunday, the following Monday shall be a designated legal holiday. When January 1<sup>st</sup>, February 12<sup>th</sup>, July 4<sup>th</sup>, November 11<sup>th</sup>, or December 25<sup>th</sup> fall on a Saturday, the preceding Friday shall be a designated legal holiday.

Full compensation for furnishing, erecting, maintaining, removing and disposing of the signs shall be considered as included in the contract lump sum price paid for Traffic Control System and no additional compensation will be allowed therefor.



### **MINOR CONCRETE SIDEWALK (MAINTENANCE PAD):**

Minor Concrete sidewalk (maintenance pad) shall be constructed in accordance with the County of Riverside Road Improvement Standards and Specifications and in conformance with Sections 51, 73 and 90 of the Standard Specifications.

Class 3 concrete shall be used for sidewalk (Maintenance Pad).

Preparation of subgrade for the concrete structures shall be done in conformance with the requirements of Section 73-1.02 of the Standard Specifications.

Excess material resulting from the excavation of the subgrade shall be disposed of as elsewhere provided in these Special Specifications.

The Contractor is responsible for meeting requirements of all American with Disability Act (ADA). Construction of sidewalk shall include, but not be limited to, the following:

- 1) Removal and disposal of existing sidewalk, curb, and/or curb and gutter and existing soil and aggregate as required;
- 2) Establishing grades, and assuring that all grades are met;
- 3) Performing all grading and compaction – including all required aggregate import, as directed by the Engineer and in accordance with County Standard 403;
- 4) Construction of new sidewalk maintenance pad;
- 5) All scoring/grooving and required saw cutting;
- 6) Repair of existing asphalt and PCC surfacing;
- 7) Installing 1/2" wide expansion joints;
- 8) All landscaping, and related work, to return the area adjacent to the maintenance pad to its original condition and to conform the area to the new improvements;

The area behind and along the sidewalk (maintenance pad) shall be filled and compacted with native or select material and graded to match and provide a smooth transition from the back of sidewalk, to the satisfaction of the Engineer.

The contract unit bid prices paid per square foot for Minor Concrete sidewalk (maintenance pad) at various locations shall include full compensation for furnishing all labor, equipment, materials and tools, and incidentals, and for doing all the work involved including concrete pad placed adjacent to the BBS cabinet at applicable location as directed by the Engineer, and no additional compensation will be allowed therefor.

### **CONDUCTORS AND CIRCUIT BREAKER REPLACEMENT:**

Conductors shall conform to the provisions in Section 86-2.08, "Conductors", of the Standard Specifications and these Special Provisions.

Multiple circuit conductors shall conform to the provisions in Section 86-2.08B, "Multiple Circuit Conductors", of the Standard Specifications and these Special Provisions.

Wiring shall conform to the provisions in Section 86-2.09, "Wiring", of the Standard Specifications and these Special Provisions.

Where splice is required, Type C or Type T splice shall be used and insulated with "Method B" as shown in the Standard Plans, ES-13A.

Service cabinet signal circuit breaker shall be replaced with a 30 amp 1 pole circuit breaker of equal quality and shall be UL approved.

Full compensation to furnish and install circuit breakers shall be considered as included in the unit price bid for conductor replacement and no additional compensation will be allowed.

The contract unit bid prices paid per linear foot for conductors replacement from service cabinet to controller cabinet shall include full compensation for furnishing all labor, tools, materials, equipment and incidentals, and for doing all work involved, including service cabinet signal circuit breaker replacement, and no additional compensation will be allowed therefor.

### **LIGHT EMITTING DIODE (LED) TRAFFIC SIGNAL MODULES:**

Red and Green signal and beacon indications shall be LED modules in accordance with the Standard Specifications and these Special Provisions. All LED modules shall be furnished by the Contractor.

LED modules shall be made from the same manufacturer and all equipment shall be new and purchased by the Contractor in a single purchase for this project. Surplus equipment which may be in the Contractor's possession, will not be allowed unless specifically allowed by the Engineer. Installation of new yellow traffic signal modules shall include replacement of existing incandescent fixtures without modification to the signal housing.

### **LED CIRCULAR SIGNAL MODULE**

#### **General:**

1. The purpose of this specification is to provide the minimum performance requirements for Light Emitting Diode circular traffic signal modules hereafter called modules. This includes 8" and 12", circular vehicle traffic signal modules and 12" omni-directional arrows. All modules will comply with either the **Vehicle Traffic Control Heads – Light Emitting Diode (LED) Circular Supplement, Adopted June 27, 2005**, or the ITE arrow spec **Vehicle Traffic Control Signal heads – Light Emitting Diode (LED) Vehicle Arrow Traffic Signal Supplement, Adopted July 1, 2007**, hereafter called VTCSH for both specs, which are published by the Institute of Transportation Engineers, hereafter called ITE. The following requirements are in addition to, or clarification of the VTCSH.
2. All modules must fit in existing signal housings without the use of special tools.
3. All modules must be certified in the **Intertek LED Traffic Signal Modules Certification Program** and be labeled with the ETL Verified Label shown in Figure 1.

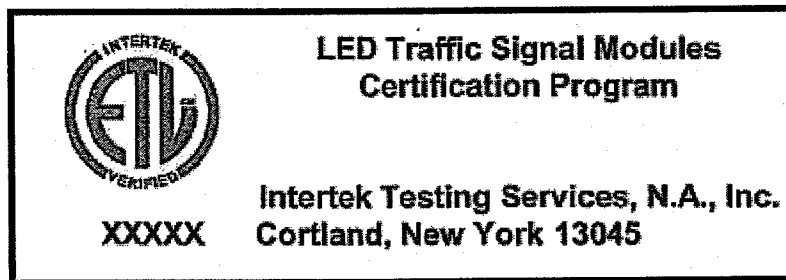

Figure 1 -- Intertek- ETL Verified Label

4. Luminous intensity requirements of the VTCSH must be met across the entire temperature range from  $-40^{\circ}\text{C}$  to  $+74^{\circ}\text{C}$ , ( $-40^{\circ}\text{F}$  to  $+165^{\circ}\text{F}$ ).
5. The following cable colors shall be used for the AC power leads on all modules: white for common, red for the red module line, yellow for the yellow module line, and brown for the green module line.
6. The AC power leads shall exit the module via a rubber grommited strain relief, and shall be terminated with quick connect terminals with spade tab adapters. The lead shall be separate at the point at which they leave the module.
7. All external wiring used in the module shall be anti-capillary type cable to prevent the wicking of moisture to the interior of the module.
8. All power supplies shall be conformally coated for additional moisture and thermal protection.
9. The module shall have an incandescent, non-pixelated appearance when illuminated.
10. Nominal power usage is measured at  $25^{\circ}\text{C}$ , 120 VAC. For the 8" modules it shall not exceed 8 watts for Red, 8 watts for Yellow, and 8 watts for Green modules. For the 12" modules it shall not exceed 10 watts for Red, 19 watts for Yellow, and 11 watts for Green modules. For the arrows it shall not exceed 6 watts for any color.
11. All modules shall use LEDs that have been manufactured with materials that have industry acceptance as being suitable for uses in outdoor applications. At no time is the use of LEDs that utilize AlGaAs technology acceptable.
12. The external lens shall have a smooth outer surface to prevent the build up of dirt & dust and shall be designed to minimize the potential for sun phantom signals.
13. The module lens material must be tinted for bids that require tinted lens. A tinted transparent film or coating is not permitted. Individual bids may require clear, non-tinted lenses.
14. A module shall be sealed against dust and moisture intrusion, including rain and blowing rain per Mil-Std-810F Method 506.4, Procedure 1.

15. Arrow modules shall be clearly marked with the phrase "Suitable for mounting in any orientation".

## **LED PROGRAMMED VISIBILITY (PV) SIGNAL MODULE**

### **General:**

1. The module shall be a Type 2 module designed and constructed to be installed in a programmed PV signal housing without modification to the housing. The LEDs shall be spread evenly across the module. See State of California Pre-Qualified Product List for accepted vendors for PV Traffic Signal Modules.

## **WARRANTY**

### **General:**

1. Manufacturers shall provide a written 5 years minimum warranty.
2. Modules shall, at the manufacturer's option, be repaired or replaced if the module fails to function as intended due to workmanship or material defects within warranty period.
3. Modules shall, at the manufacturer's option, be repaired or replaced if the module exhibit luminous intensities less than the minimum specified values within the first 60 months of the date of delivery.
4. Upon request, the LED lamp module manufacturer shall provide written documentation of its ability to satisfy a worst-case, catastrophic warranty claim. A current corporate annual report duly-certified by an independent auditing firm, containing financial statements illustrating sufficient cash-on-hand and net worth to satisfy a worst-case, catastrophic warranty claim is an example of suitable documentation.
5. The documentation shall clearly disclose the country in which the factory of module origin is located, the name of the company or organization that owns the factory including all of its parent companies and/or organizations, and their respective country of corporate citizenship.

## **PAYMENT**

The contract unit bid prices paid per each for LED Traffic Signal Module shall include full compensation for furnishing all labor, tools, materials, equipment and incidentals, and for doing all work involved including the removal and disposal of existing LED traffic signal modules and existing incandescent fixtures and no additional compensation will be allowed therefor.

## **BATTERY BACK-UP SYSTEM (BBS):**

This special provision establishes the minimum requirements for a battery backup system (BBS) that shall provide power to a traffic signal system in the event of a power failure or interruption.

The BBS shall be designed for outdoor applications, in accordance with the current edition of Chapter 1, Section 8 requirements of Transportation Electrical Equipment Specifications (TEES).

The BBS batteries shall be external to the traffic signal controller cabinet as specified under "External Battery Cabinet Option" herein unless specified otherwise. The supplied external cabinet shall be listed on the current Caltrans pre-qualified product list for the external BBS cabinet.

The BBS shall have been installed and operational for a period of one year at an signalized intersection in the United States. The supplied BBS shall be listed on the current Caltrans pre-qualified product list for the BBS.

The BBS shall include, but not limited to the following: cabinet, utility line/generator switch, inverter/charger, power transfer relay, a separate manually operated non-electronic bypass switch, batteries, and all necessary hardware, shelving, and interconnect wiring. The following figure shows BBS components interconnecting with each other and the controller cabinet to ensure interchangeability between all BBS manufacturers.

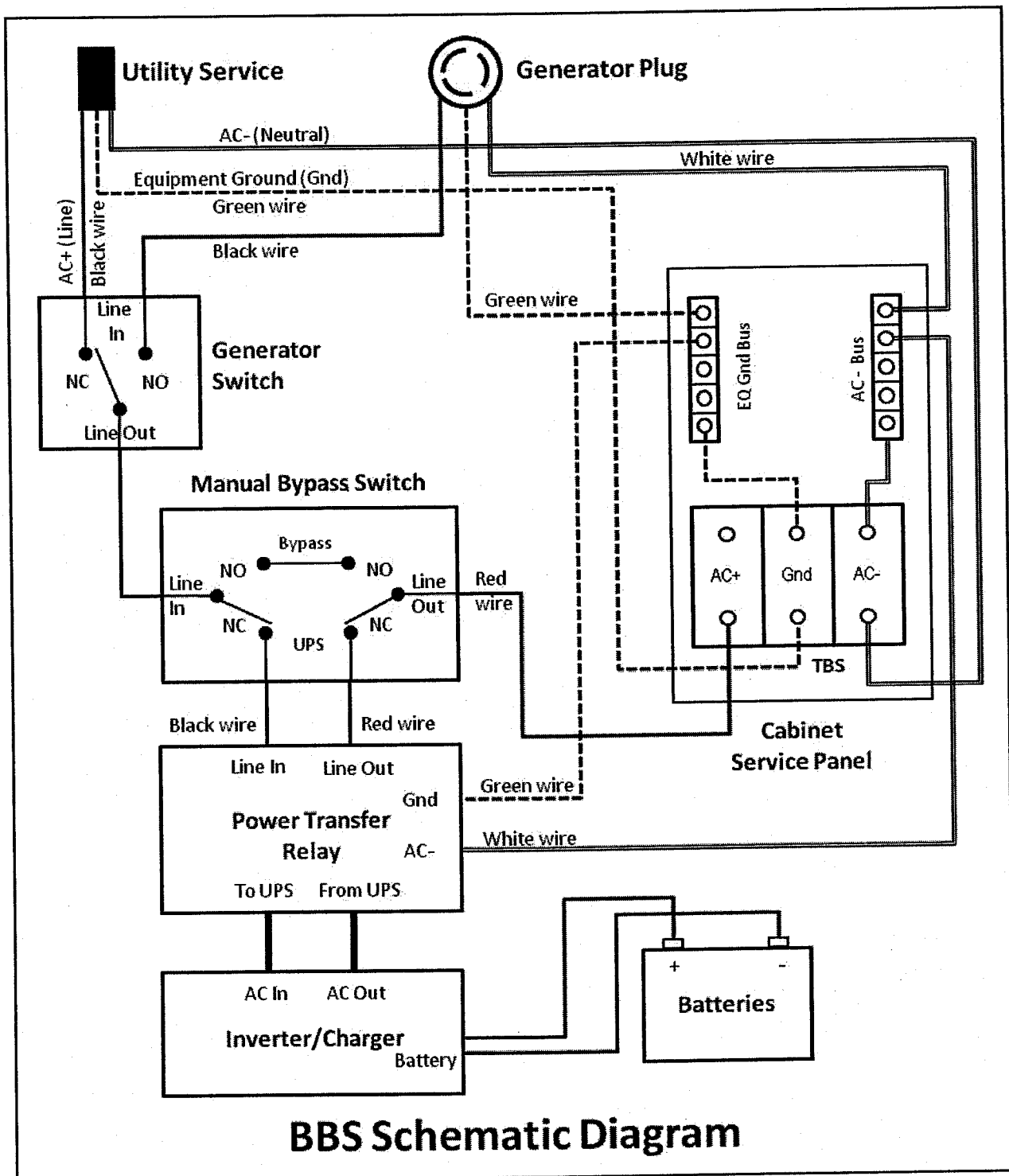

**BBS Schematic Diagram**

**Operation**

The BBS shall provide a minimum two (2) hours of full run-time operation for an intersection equipped with all LED traffic signal indications (minimum 1100W active output capacity, with 80% minimum inverter efficiency).

The maximum transfer time allowed, from disruption of normal utility line voltage to stabilized inverter line voltage from batteries, shall be 65 milliseconds. The same maximum allowable transfer time shall also apply when switching from inverter line voltage to utility line voltage.

The BBS shall provide the user with six (6)-sets of fully programmable normally open (NO) and normally closed (NC) single-pole double-throw (SPDT) dry relay contact closures, available on a panel-mounted terminal block, rated at a minimum 120V/1A, and labeled so as to identify each contact. See below figure for typical configuration.

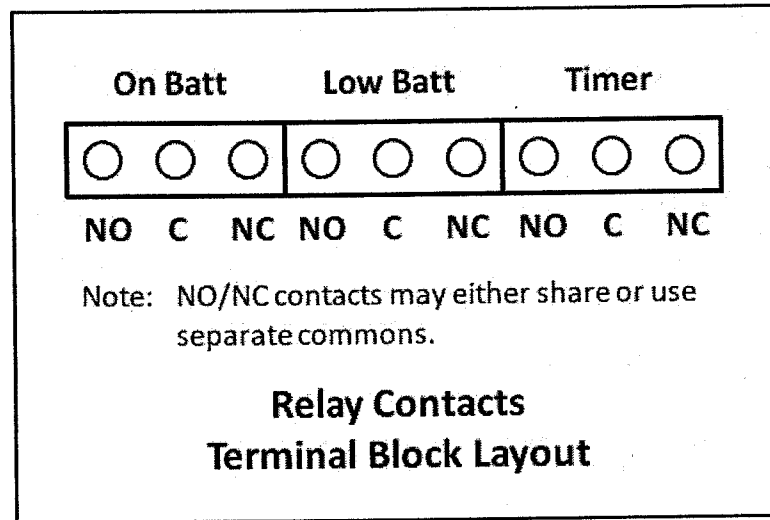

The first set of NO and NC contact closures shall be energized whenever the unit switches to battery power. Contact shall be labeled or marked "On Batt".

The second set of NO and NC contact closures shall be energized whenever the battery approaches approximately 40% of remaining useful capacity. Contact shall be labeled or marked "Low Batt".

The third set of NO and NC contact closures shall be energized two hours after the unit switches to battery power. Contact shall be labeled or marked "Timer".

The six programmable NO and NC contact closures shall be independently configured to activate under any of the following conditions: On Battery, Low Battery, Timer, Alarm, or Fault.

Operating temperature for inverter/charger, power transfer relay and manual bypass switch shall be  $-37\text{ }^{\circ}\text{C}$  to  $+74\text{ }^{\circ}\text{C}$ .

Both the Power Transfer Relay and Manual Bypass Switch shall be rated at 240VAC/30 amps, minimum.

The BBS shall use a temperature-compensated battery charging system. The charging system shall compensate over a range of  $2.5 - 4.0\text{ mV/ }^{\circ}\text{C}$  per cell.

The temperature sensor shall be external to the inverter/charger unit. The temperature sensor shall come with 10' of wire.

Batteries shall not be recharged when battery temperature exceeds  $50\text{ }^{\circ}\text{C} \pm 3\text{ }^{\circ}\text{C}$ .

BBS shall bypass the utility line power whenever the utility line voltage is outside of the following voltage range: 100VAC to 130VAC ( $\pm 2\text{VAC}$ ).

When utilizing battery power, the BBS output voltage shall be between 110 VAC and 125 VAC, pure sine wave output,  $\leq 3\%$  THD,  $60\text{Hz} \pm 3\text{Hz}$ .

BBS shall be compatible with NEMA and Model 332 and 333JP Cabinets, and Model 170, 390 & 2070 Controllers and cabinet components for full time operation.

In cases of low (below 100VAC) or absent utility line power, when the utility line power has been restored at above  $105\text{ VAC} \pm 2\text{ VAC}$  for more than 30 seconds, the BBS shall transfer from battery backed inverter mode back to utility line mode.

In cases of high utility line power (above 130VAC), when the utility line power has been restored at below  $125\text{VAC} \pm 2\text{ VAC}$  for more than 30 seconds, the BBS shall transfer from battery backed inverter mode back to utility line mode.

The BBS shall have an automatic tap to step up or step down the output voltage by 10 percent. The resulting output voltages shall remain within the above prescribed voltage range: 100VAC to 130VAC. This capability will extend BBS range for operating on input AC and not reverting to battery power.

BBS shall be equipped to prevent a malfunction feedback to the cabinet or from feeding back to the utility service.

In the event of inverter/charger failure, battery failure or complete battery discharge, the power transfer relay shall revert to the NC (and de-energized) state, where utility line power is connected to the cabinet.

Recharge time for the battery, from "protective low-cutoff" to 80% or more of full battery charge capacity, shall not exceed twenty (20) hours.

### **Mounting / Configuration**

Generator Switch, Inverter/Charger, Power Transfer Relay and manually operated Bypass Switch shall fit inside a typical fully equipped traffic signal controller cabinet.

Mounting method inside the 332 and 333JP cabinet shall be shelf-mount, rack-mount or combination of either. Available rack space for front-mounted inside the 332 and 333JP cabinet is 3U or approximately 6 inches.

All interconnect wiring provided between Generator Switch, Inverter/Charger, Power Transfer Relay, Bypass Switch and Cabinet Terminal Service Block shall be no less than 9 feet of UL Style 1015 CSA TEW with the following characteristics:



- AWG Rating: 10 AWG
- Stranding: 105 strands of 10 AWG tinned copper
- Rating: 600 V, 105 °C, PVC Insulation

Relay contact wiring provided for each set of NO/NC relay contact closure terminals shall be 9 feet of UL Style 1015 CSA TEW 18 AWG wire, same rating as above, except 16 strands of 18 AWG tinned copper.

All necessary hardware for mounting (shelf angles, rack, etc) shall be included in the **contract price paid** for the BBS, and no additional compensation will be allowed therefor.

### **Internal mounted battery option**

The controller cabinet shall be equipped with a generator twist lock flanged inlet receptable and manual transfer switch.

The twist lock flanged inlet receptacle shall be Hubbell 2615, NEMA L5-30P Twist Lock Flanged Male Inlet Rated for 30A/125VAC or approved equal. Receptacle shall be mounted flush to the cabinet in a weatherproof lift cover plate made of impact-resistant thermoplastic and gray in color.

The bypass switch shall transfer the load, including the UPS to the twist lock inlet receptacle. The manual transfer switch shall be wired to prevent any back feed to the utility service. Both the bypass switch and manual transfer switch shall be rack mounted independently in the controller cabinet meeting industry standards.

Batteries shall be mounted on swing-tray mounted below the controller shelf. A minimum of six (6) bolts/fasteners shall be used to secure swing-trays to the 332 Cabinet standard EIA 19" rack. All bolts/fasteners and washers shall meet the following requirements:

- Screw type: Pan Head Phillips machine screw
- Size and Thread pitch: 10-32
- Material: 18-8 stainless steel (Type 316 stainless steel is acceptable as an alternate)
- Washer: Use one 18-8 stainless steel flat washer under the head of each 10-32 screw; lock washers are unnecessary provided that the screws are properly tightened.

Number of screws per swivel bracket: minimum six (6) screws per swivel bracket. Screws are to be spaced evenly along bracket, with one screw near each end. Batteries may be shelf mounted in area behind controller so long as shelf and batteries do not interfere with controller unit and C1 plug.

### **External battery cabinet option**

Batteries shall be housed in an external cabinet mounted to the side of the controller cabinet as shown in the following figure or as directed by the Engineer with a minimum of eight (8) bolts:

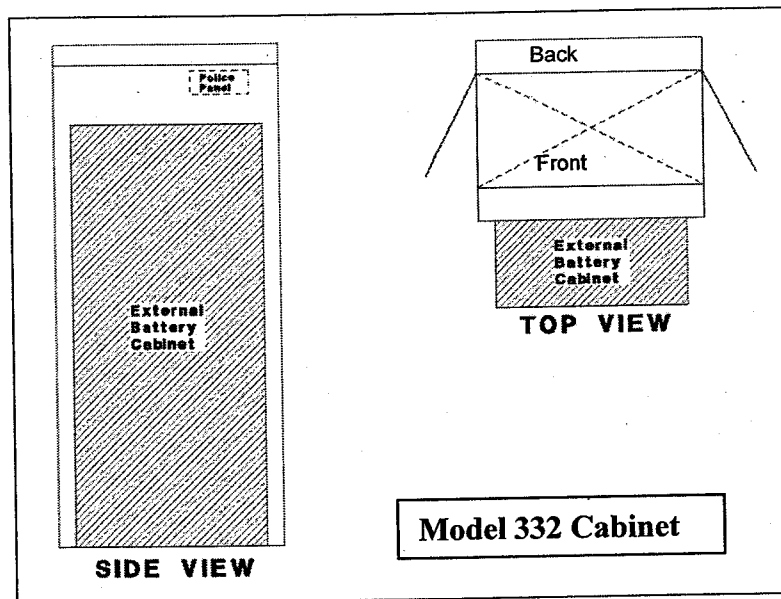

If BBS is installed at the back of controller cabinet, the modification shall include a minimum of 36 inches wide concrete walkway access to the BBS without encroaching outside the right-of-way. BBS shall be installed at the front of the controller cabinet (in locations where the back of the controller cabinet has limited ROW or conflicting structures and facilities and other obstructions), the BBS cabinet shall not cover the police panel. The BBS cabinet shall also not hinder the access ramp's compliance with ADA requirements.

Four shelves shall be provided within the battery cabinet. There shall be a minimum of 12 inches clearance between shelves. Each shelf shall be a minimum of 9" X 25", and capable of supporting a minimum of 125 lbs. Batteries shall be mounted on individual shelves.

The external battery cabinet shall be NEMA 3R rated in accordance to Section 2-Housings of the Chapter 7 of TEES, for the construction of the cabinet and anodic coating finish.

The external battery cabinet shall be ventilated through the use of louvered vents, filter, and one thermostatically controlled fan in accordance to Section 2-Housings of the Chapter 7 of TEES.

External battery cabinet fan shall be AC operated from the same line output of the Manual Bypass Switch that supplies power to the controller cabinet.

The external battery cabinet shall have a door opening to the entire cabinet. The door shall be attached to the cabinet through the use of a continuous stainless steel piano hinge or four, two-bolts per leaf, hinges in accordance to Section 2-Housings of the Chapter 7 of TEES. The door shall use a three-point, roller locking mechanism and standard #2 key lock to lock the door. The door shall have a stainless steel handle.

The external cabinet shall be equipped with a generator twist lock flanged inlet receptacle and manual transfer switch and bypass switch.

The twist lock flanged inlet receptacle shall be Hubbell HBL2615, NEMA L5-30P, Twist Lock Flanged Male Inlet Rated for 30A/125V or approved equal. Receptacle shall be mounted flush to

the cabinet in a weatherproof lift cover plate made of impact-resistant thermoplastic and gray in color.

The bypass switch shall transfer the load, including the UPS to the twist lock inlet receptacle. The manual transfer switch shall be wired to prevent any back feed to the utility service. Both the bypass switch and manual transfer switch shall be rack mounted independently in BBS cabinet meeting industry standards.

The BBS with external battery cabinet shall come with all bolts, conduits and bushings, gaskets, shelves, and hardware needed for mounting.

### **Maintenance, Displays, Controls and Diagnostics**

The BBS shall include a 2 line by 40 character LCD display to indicate current battery charge status, input/output voltages, time and settings of various conditions. The same parameters shall be available via RS232 or USB interfaces on the face of the BBS.

The BBS shall have lightning surge protection compliant with IEEE/ANSI C.62.41.

The BBS shall be capable of accepting firmware upgrades of the non-volatile, read-only memory via serial port communications. The updates shall be accomplished by uploading the software to the BBS over the RS232 serial port located on the face of the BBS.

The BBS shall be equipped with an integral system to prevent battery from destructive discharge and overcharge.

The BBS shall be capable of performing a SELF-TEST, locally from the BBS front panel LCD, or remotely via RS232 or USB interface. The duration of the SELF-TEST shall be programmable in 1-minute increments from 1 minute to 255 minutes.

The BBS and batteries shall be easily replaced with all needed hardware and shall not require any special tools for installation.

The BBS shall include a re-settable inverter event counter to indicate the number of times the BBS was activated and the total number of hours the unit has operated on battery power, accessible via the LCD screen or remotely via RS232 or USB.

The BBS shall be equipped with an event log that stores for a minimum the last 100 events. The events shall be time and date stamped. The event log shall be retrievable via RS232, USB or from the BBS LCD screen. The event log shall be display and print out in plain English when output the RS232 or USB ports.

### **Battery System**

Individual batteries shall be 12V, 105 amp-hour for 20 hours to 1.70 VPC @ 77F and shall be easily replaced and commercially available off the shelf.

Batteries used for BBS shall consist of four (4) batteries with a cumulative minimum rated capacity of 420 amp-hours.

Batteries shall be deep cycle, sealed prismatic lead-calcium based AGM/VRLA (Absorbed Glass Mat/ Valve Regulated Lead Acid).

Batteries shall be certified by the manufacturer to operate over a temperature range of  $-25^{\circ}\text{C}$  to  $+74^{\circ}\text{C}$ .

The batteries shall be provided with appropriate interconnect wiring and corrosion-resistant mounting trays and/or brackets appropriate for the cabinet into which they will be installed.

Batteries shall indicate maximum recharge data and recharging cycles.

### **Battery Harness**

Battery interconnect wiring shall be via two-part modular harness:

- Part I shall be equipped with red (+) and black (-) cabling that can be permanently connected to the positive and negative posts of each battery. Each red and black pair shall be terminated into a Molex, polarized – keyed battery cable connector or equivalent. The length of the harness between batteries shall be a minimum of 12 inches.
- Part II shall be equipped with the mating Power Pole style connector for the batteries and a single, insulated Power Pole style connection to the inverter/charger unit. Harness shall be fully insulated and constructed to allow batteries to be quickly and easily connected in any order to ensure proper polarity and circuit configuration. The length of the battery interconnect harness shall be a minimum of 60 inches from the Inverter/Charger plug to the first battery in the string.

Power Pole connectors may be either one-piece or two-piece. If a two-piece connector is used, a locking pin shall be used to prevent the connectors from separating.

All battery interconnect harness wiring shall be UL Style 1015 CSA TEW or Welding Style Cable or equivalent, all of proper gauge with respect to design current and with sufficient strand count for flexibility and ease of handling.

Battery terminals shall be covered and insulated with molded boots to prevent accidental shorting.

### **BBS Quality Assurance**

Each Battery Backup System (BBS) shall be manufactured in accordance with a manufacturer Quality Assurance (QA) program. The QA program shall include two Quality Assurance procedures:

1. Design QA - The manufacturer, or an independent testing lab hired by the manufacturer, shall perform Design Qualification Testing on new BBS system(s) offered, and when any major design change has been implemented on an existing design. A major design change

is defined as any modification - material, electrical, physical, or theoretical, that changes any performance characteristics of the system, or results in a different circuit configuration. Where a dispute arises in determining if a system is a new design or if the system has had a major design change, the County will make the final determination if Design Qualification Testing is required prior to production consideration.

2. Production QA - The Production QA shall include statistically controlled routine tests to ensure minimum performance levels of BBS units built to meet this specification and a documented process of how problems are to be resolved.

QA process and test results documentation shall be kept on file for a minimum period of seven years.

Battery Backup System designs not satisfying Design QA Testing and Production QA Testing requirements shall not be labeled, advertised, or sold as conforming to this specification.

The Contractor shall arrange to have a technician, qualified to work on the battery backup system and employed by the battery backup system manufacturer or employed by the manufacturers authorized distributor, present at the time the equipment is turned on. It shall be the responsibility of the Contractor to implement and fund any traffic signal controller assembly modifications required to achieve the traffic signal operation as shown on the construction plans and as required in the Special Provisions.

#### **Payment**

The contract unit price paid per each for battery backup system shall include full compensation for furnishing all labor, tools, materials, equipment and incidentals, and for doing all the work involved to mount BBS externally or internally as specified in these special provisions and as directed by the Engineer, no additional compensation will be allowed therefor.

#### **OBSTRUCTIONS:**

Attention is directed to Sections 8-1.10, "Utility and Non-Highway Facilities", and 15, "Existing Highway Facilities" of the Standard Specifications and these Special Provisions.

Existing utility and privately owned facilities shall be protected in accordance with Section 7-1.11, "Preservation of Property" and these Special Provisions. The Contractor is also responsible to protect those facilities that are to be relocated by others prior to or during construction, and shall protect those facilities in both their existing and their ultimate locations. The Contractor shall cooperate with owners and their Contractors of utility and privately owned facilities, for the relocation of said facilities, in accordance with Section 7-1.14, "Cooperation" of the Standard Specifications.

All water valves, gas valves, sewer manholes, survey monuments, survey markers and any other utility appurtenances shall be protected in place. Full compensation for such protection shall be considered as included in the various bid items.

The Contractor's attention is directed to the existence of certain underground facilities that may require special precautions be taken by the Contractor to protect the health, safety and welfare of workmen and the public. Facilities requiring special precautions include, but are not limited to: conductors of petroleum products, oxygen, chlorine, and toxic or flammable gases; natural gas in pipe lines greater than 6 inches in diameter or pipe lines operating at pressures greater than 60 psi (gage); underground electric supply system conductors or cables either directly buried or in duct or conduit which do not have concentric neutral conductors or other effectively grounded metal shields or sheaths; and underground electrical conductors with potential to ground of more than 300 volts. The Contractor shall notify the Engineer at least twenty-four hours prior to performing any work in the vicinity of such facilities.

Attention is directed to the requirements of Government Code Sections 4216-4216.9 pertaining to existing utility facilities.

The Contractor shall assume that every house, building and lot within the project limits has utility service pipes and conductors (laterals), and that utility main and trunk facilities exist within the project limits. The Contractor shall determine if it is warranted to determine the exact location of these utility service laterals and existing main lines, unless directed by the Engineer to pot-hole at specific locations, or as otherwise required herein. The Contractor will not be directly reimbursed for determining the exact location of the utility main lines or services laterals but shall include any compensation for this work in the contract price paid for the various items of work. Any damage to existing main lines or service laterals for which pot-holing was not performed shall be considered damage due to not using reasonable care and the damage shall be repaired at the Contractor's expense.

The Contractor shall conduct his operations with the assumption that underground utility facilities exist within the project limits. The Contractor shall exercise caution and best construction practices for safety and for protection of underground facilities. The approximate locations of underground utility facilities, as shown on the plans, are based on information provided by the respective owners, listed below. The Contractor shall also utilize the markings of the regional notification center (Underground Service Alert), and above-ground utility appurtenances to determine the existence and approximate location of underground utilities.

No excavation shall be made within 4 feet of any underground utilities, as listed below, unless and until such utilities have been positively located as to horizontal and vertical position. This requirement applies to all underground electric, natural gas, toxic or flammable gas, chlorine, oxygen or petroleum facilities.

Forty-eight hours prior to beginning construction, the Contractor shall notify the following agencies:

Under Ground Service Alert: 800-227-2600

Full compensation for all costs, including labor, equipment, materials and incidentals, required to comply with the requirements of this section shall be considered as included in the various items of work, and no additional compensation will be allowed therefor.

## **DE-MOBILIZATION:**

De-mobilization shall consist of the completion of all final construction, cleanup work, incidentals to the project site(s), and administrative work required to secure the project for termination and acceptance by the Engineer, including, but not limited to the following:

1. Removal of all temporary facilities, temporary utilities, equipment, surplus material, construction debris and similar objects from project limits and adjacent property, as required and as directed by the Engineer.
2. Submission of final certified payroll documents to the Engineer.
3. Satisfactory completion of punch list items, all construction items, and administrative items of work.

De-Mobilization shall include the satisfactory completion of all items of work, but shall not be construed as being a separate payment for work that is paid under separate contract items. The contract item for De-Mobilization is intended for project close-out activities.

### ***Method of Payment***

Payment for De-Mobilization will be made on a lump-sum basis in the amount of the fixed bid price after satisfactory completion of the above listed items. Payment for De-Mobilization will be included in the final pay estimate and payment. No partial payments will be made for De-Mobilization

COUNTY WIDE BATTERY BACKUP & LED RETROFIT PROJECT PHASE 3

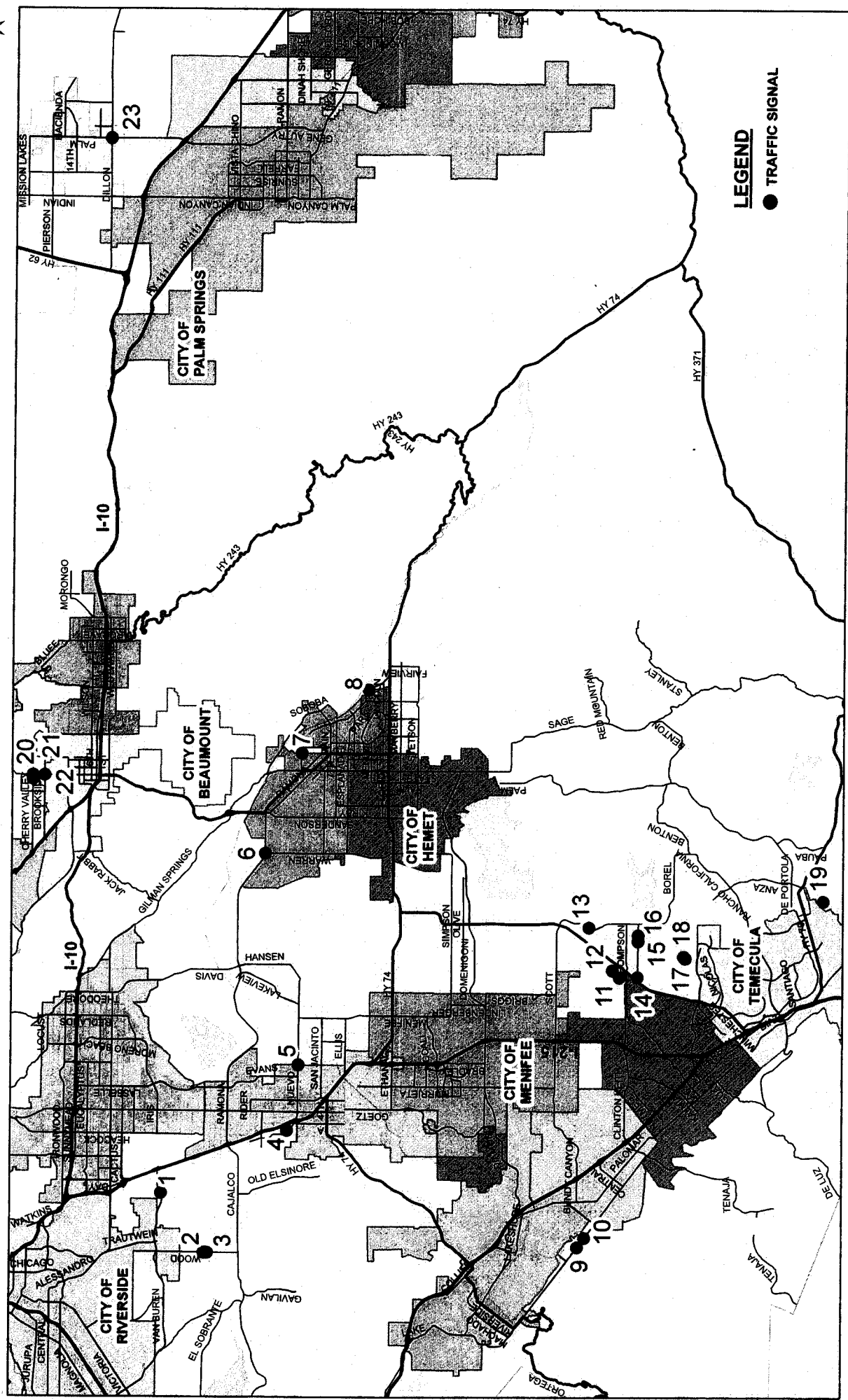

**LEGEND**  
● TRAFFIC SIGNAL





## **REFERENCE DRAWINGS**

DIST	COUNTY	ROUTE	POST MILES TOTAL PROJECT	SHEET NO.	TOTAL SHEETS

**REGISTERED ELECTRICAL ENGINEER**  
*Jeffrey S. Moberg*  
 No. E14512  
 Exp. 8-30-06  
 The State Board of Electrical Engineers  
 Department of Industrial Relations  
 1700 North Street, Sacramento, CA 95833  
 To get to the California web site, go to the URL: <http://www.sdspe.org>

MAY 1, 2006  
 LICENSE RENEWAL DATE  
 The State Board of Electrical Engineers  
 Department of Industrial Relations  
 1700 North Street, Sacramento, CA 95833

**NOTES:**

1. Dimensions are minimum.
2. Rubber tapes shall be roiled after application.

**INSULATION METHODS**

**Low Voltage Circuits (0-600 V)**

**METHOD "B"**

1. Completely cover the splice area with electrical insulating coating and allow to dry.
2. Apply 2 layers of electrical insulating pad with electrical insulating tape, half lapped, half lapped, half lapped, half lapped, half lapped, synthetic oil resistant, self fusing rubber tape.
3. Apply 3 layers half lapped polyvinyl chloride tape.
4. Cover entire splice with electrical insulating coating and allow to dry.

**High Voltage Circuits (Over 600 V)**

1. Completely cover the splice area with electrical insulating coating and allow to dry.
2. Apply high voltage tape to a minimum thickness equal to original insulation.
3. Apply 3 layers half lapped polyvinyl chloride tape.
4. Cover entire splice with electrical insulating coating and allow to dry.

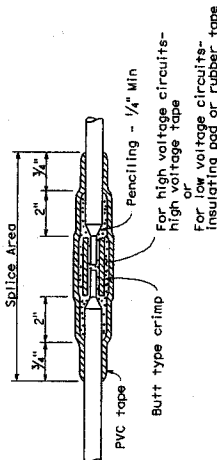

**TYPE "S" SPLICE**  
Between 2 free-ends

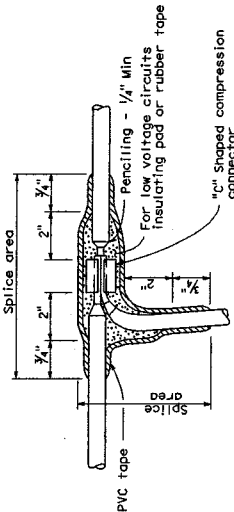

**TYPE "T" SPLICE**  
For 3 free-ends

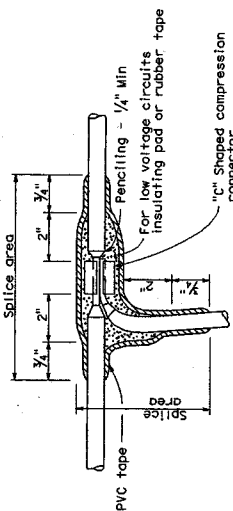

**TYPE "C" SPLICE**  
Between 1 free-end and 1 through conductor

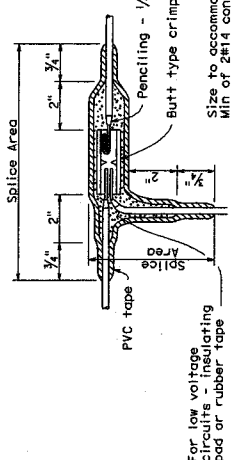

**TYPE "ST" SPLICE**

STATE OF CALIFORNIA  
DEPARTMENT OF TRANSPORTATION  
**ELECTRICAL SYSTEMS  
(SPLICING DETAILS)**

NO SCALE

**ES-13A**



OFFICE OF  
CLERK OF THE BOARD OF SUPERVISORS  
1st FLOOR, COUNTY ADMINISTRATIVE CENTER  
P.O. BOX 1147, 4080 LEMON STREET  
RIVERSIDE, CA 92502-1147  
PHONE: (951) 955-1060  
FAX: (951) 955-1071

KECIA HARPER-IHEM  
Clerk of the Board of Supervisors

KIMBERLY A. RECTOR  
Assistant Clerk of the Board

April 25, 2013

THE PRESS ENTERPRISE  
ATTN: LEGALS  
PO BOX 792  
RIVERSIDE, CA 92501

FAX (951) 368-9018  
E-MAIL: [legals@pe.com](mailto:legals@pe.com)

**RE: NOTICE INVITING BIDS: COUNTYWIDE TRAFFIC SIGNAL BATTERY BACK UP  
& LED MODULES B9-0996**

To Whom It May Concern:

Attached is a copy for publication in your newspaper for **TEN (10) TIMES:**

Sunday	- April 28, 2013	Friday	- May 3, 2013
Monday	- April 29, 2013	Saturday	- May 4, 2013
Tuesday	- April 30, 2013	Sunday	- May 5, 2013
Wednesday	- May 1, 2013	Monday	- May 6, 2013
Thursday	- May 2, 2013	Tuesday	- May 7, 2013

We require your affidavit of publication immediately upon completion of the last publication.

Your invoice must be submitted to this office in duplicate, WITH TWO CLIPPINGS OF THE PUBLICATION.

**NOTE: PLEASE COMPOSE THIS PUBLICATION INTO A SINGLE COLUMN FORMAT.**

Thank you in advance for your assistance and expertise.

Sincerely,

*Cecilia Gil*

Board Assistant to:  
KECIA HARPER-IHEM, CLERK OF THE BOARD

**Gil, Cecilia**

---

**From:** mtinajero@pe.com on behalf of Master, PEC Legals <legalsmaster@pe.com>  
**Sent:** Thursday, April 25, 2013 8:13 AM  
**To:** Gil, Cecilia  
**Subject:** Re: [Legals] FOR PUBLICATION: Bids for B9-0996

Received for publication from April 28 to May 7. Proof with cost to follow.

Thank You!



Publisher of The Press-Enterprise  
Inland Southern California's News Leader

**Legal Advertising**

**Phone:** 1.800.880.0345

**Fax:** 951.368.9018

**E-mail:** [legals@pe.com](mailto:legals@pe.com)

**Please Note:** Deadline is 10:30 AM two (2) business days prior to the date you would like to publish.  
**\*\*Additional days required for larger ad sizes\*\***

On Wed, Apr 24, 2013 at 5:21 PM, Gil, Cecilia <[CCGIL@rcbos.org](mailto:CCGIL@rcbos.org)> wrote:

Notice Inviting Bids attached for publication from April 28 to May 7, 2013. Please confirm. **THANK YOU!**

***Cecilia Gil***

Board Assistant to the  
Clerk of the Board of Supervisors  
951-955-8464

**THE COUNTY ADMINISTRATIVE CENTER IS CLOSED EVERY FRIDAY UNTIL FURTHER NOTICE.**

**PLEASE CONSIDER THE ENVIRONMENT BEFORE PRINTING.**

**NOTICE INVITING BIDS**

County of Riverside, herein called Owner, invites sealed proposals for:

**COUNTYWIDE TRAFFIC SIGNAL  
BATTERY BACKUP SYSTEM AND  
LED MODULES IMPROVEMENT PROJECT  
AT VARIOUS LOCATIONS**

**PHASE-3**

**PROJECT NO. B9-0996**

Proposal shall be delivered to the Riverside County Transportation Department, 14<sup>th</sup> Street Annex, 3525 14<sup>th</sup> Street, Riverside, California 92501, telephone (951) 955-6780 not later than 2:00 p.m., on **Wednesday, May 15, 2013**, to be promptly opened in public at said address. Each proposal shall be in accordance with plans, specifications, and other contract documents, dated **March 2013**, and prepared by County of Riverside, whose address is same as the above, from whom they may be obtained upon deposit of **\$25** per set, plus mailing. No refund. Prospective bidders may preview the plans, specifications and other contract documents, at no charge prior to purchase, at the above noted location.

The Contractor is required to have a Class "A" license or Class "C-10" License at the time of bid submission.

Engineering Estimate	\$160,500.00 - \$168,500.00
Bid Bond	10%
Performance Bond	100%
Payment Bond	100%
Working Days	35 Working Days

Dated: April 25, 2013

Kecia Harper-Ihem, Clerk of the Board  
By: Cecilia Gil, Board Assistant