

**SUBMITTAL TO THE BOARD OF SUPERVISORS
COUNTY OF RIVERSIDE, STATE OF CALIFORNIA**

823



SUBMITTAL DATE:
June 6, 2013

FROM: Successor Agency to the Redevelopment Agency

SUBJECT: Cabazon Civic Center – Notice of Completion

RECOMMENDED MOTION: That the Board of Supervisors:

1. Ratify and authorize the Chairman of the Board to execute the attached Change Order Nos. 14, 15, 16, and 17 between Doug Wall Construction and the Successor Agency in the amount of \$206,068;
2. Accept the construction of the Cabazon Civic Center Project as complete and authorize the release of retention in the amount of \$659,375.03, pursuant to Section 22200 of the California Public Contract Code, 35 days after recording the Notice of Completion;
3. Authorize the Chairman to execute the attached Notice of Completion for the project;

(Continued)

REVIEWED BY CIP
Christopher Hans
Christopher Hans

Robert Field
Robert Field
Assistant County Executive Officer/EDA

| | | | | |
|-----------------------|-------------------------------|------------|-------------------------|---------|
| FINANCIAL DATA | Current F.Y. Total Cost: | \$ 214,106 | In Current Year Budget: | Yes |
| | Current F.Y. Net County Cost: | \$ 0 | Budget Adjustment: | No |
| | Annual Net County Cost: | \$ 0 | For Fiscal Year: | 2012/13 |

COMPANION ITEM ON BOARD AGENDA: No

| | | |
|--|---|--------------------------|
| SOURCE OF FUNDS: Mid-County Redevelopment Project Area Capital Improvement Bond Proceeds (previously approved budget) | Positions To Be Deleted Per A-30 | <input type="checkbox"/> |
| | Requires 4/5 Vote | <input type="checkbox"/> |

C.E.O. RECOMMENDATION:

APPROVE

County Executive Office Signature

BY: *Jennifer L. Sargent*
Jennifer L. Sargent

**MINUTES OF THE BOARD OF SUPERVISORS OF THE SUCCESSOR AGENCY TO
THE REDEVELOPMENT AGENCY**

On motion of Supervisor Jeffries, seconded by Supervisor Benoit and duly carried by unanimous vote, IT WAS ORDERED that the above matter is approved as recommended.

Ayes: Jeffries, Tavaglione, Stone, Benoit and Ashley
Nays: None
Absent: None
Date: June 18, 2013
xc: RDA, EDA, Auditor, CIP, Recorder

Kecia Harper-Ihem
Clerk of the Board
By: *Kecia Harper-Ihem*
Deputy

13 JUN - 11 4:52
RECEIVED RIVERSIDE COUNTY

Prev. Agn. Ref.: 4.1 of 12/18/12, 4-2 of 2/5/13 **District:** 5/5 **Agenda Number:**

FORM APPROVED COUNTY COUNSEL DATE 5/23/13 BY: MARSHAL VICTOR
FISCAL PROCEDURES APPROVED PAUL ANGLIO, CPA, AUDITOR-CONTROLLER BY: [Signature] DATE 6/13/13

RECOMMENDED MOTION: (Continued)

4. Authorize the Clerk of the Board to file the attached Notice of Completion for the project; and
5. Ratify and authorize the Chairman of the Board to execute the attached Third Amendment for Construction Phase Civil Engineering Services between the Successor Agency to the Redevelopment Agency and Armstrong & Brooks Consulting Engineers in the amount of \$8,038.

BACKGROUND:

The Cabazon Civic Center Project was awarded to Doug Wall Construction, Inc. on June 14, 2011. The attached Change Order Nos. 14, 15, 16, and 17 include work arising from unforeseen circumstances during construction, changes requested by the various building operators, and changes requested by the Successor Agency. The Change Orders are within the 10% contingency established in the project budget, which was approved on June 14, 2011.

The attached Third Amendment with Armstrong & Brooks Consulting Engineers includes work for additional civil engineering and survey staking to complete the project.

The cost of Change Order Nos. 14, 15, 16, 17 and the Third Amendment will not be an additional cost to the project as they are within the 10% contingency established in the project budget. They are also included on the Recognized Obligation Payment Schedule, as approved by the Oversight Board and the California Department of Finance. Change Order Nos. 14, 15, 16, and 17 will be processed in accordance with the terms of the original construction contract.

Pursuant to the General Conditions of the contract, the Successor Agency was allowed a 10 percent withholding for retention on all work. Retention is withheld to ensure performance of the contract, repair defective work, pay for claims or stop notices filed, compensate subcontractors that have not been paid for work performed, damages, and delays. On December 18, 2012, the Board authorized the release of 5 percent retention.

Upon acceptance of the project and recording of the Notice of Completion, if there are no stop notices filed or corrective actions required within 35 calendar days of recording, the Agency will release the remainder of retention monies being withheld to Doug Wall Construction, Inc. in the amount of \$659,375.03. The retention amount of \$659,375.03 does not reflect an increase in budget or an allocation of additional funds. The total contract amount, including this retention, is shown in the Recognized Obligation Payment Schedule.

Staff recommends approval of the motions listed above.

Attachments:

- Change Order Nos. 14, 15, 16, and 17 with backup documentation
- Third Amendment between Successor Agency and Armstrong & Brooks Consulting Engineers
- Notice of Completion

PLEASE COMPLETE THIS INFORMATION
RECORDING REQUESTED BY:

KECIA HARPER-IHEM, CLERK OF THE BOARD
RIVERSIDE CO. CLERK OF THE BOARD
4080 LEMON STREET, 1ST FLOOR CAC
P O BOX 1147 - RIVERSIDE, CA 92502

MAIL STOP # 1010

AND WHEN RECORDED MAIL TO:

RETURN TO: STOP #1010
RIVERSIDE COUNTY CLERK OF THE BOARD
P. O. BOX 1147 - RIVERSIDE, CA 92502

DOC # 2013-0295234

06/20/2013 02:32P Fee:NC

Page 1 of 2

Recorded in Official Records

County of Riverside

Larry W. Ward

Assessor, County Clerk & Recorder



| S | R | U | PAGE | SIZE | DA | MISC | LONG | RFD | COPY |
|--------|---|---|------|------|------|------|------|------|------|
| 1 | | | 2 | | | | | | |
| M | A | L | 465 | 426 | PCOR | NCOR | SMF | NCHG | EXAM |
| NCHGCC | | | | | | T: | CTY | UNI | 524 |



NOTICE OF COMPLETION

(California Civil Code §§ 8180-8190, 8100-8118)

C
524

To be recorded with County Recorder within 15 days after completion.

Notice is hereby given by the undersigned owner, a public entity of the State of California, that a public work of improvement has been completed, as follows:

Project title or description of work: Cabazon Civic Center

Date of Completion: Date Hereof 06/18/13

Nature of owner: Government, Successor to the Redevelopment Agency

Interest or estate of owner: Construction Easement /Owner

Address of owner: Successor to the Redevelopment Agency c/o County of Riverside
3403 10th Street, Suite 500, Riverside, CA 92501

Name of contractor: Doug Wall Construction, Inc., 78450 Avenue 41, Bermuda Dunes, CA 92203

Street or legal description of site: Assessor's Parcel Numbers 526-170-020, 526-170-001, and 526-170-021

Dated: May 8, 2013

Owner: County of Riverside
Successor Agency to the Redevelopment Agency

By: John J. Benoit
John J. Benoit, Chairman, Board of Supervisors

STATE OF CALIFORNIA)

ss

COUNTY OF RIVERSIDE)

I am the Chairman of the governing board of the Successor Agency to the Redevelopment Agency for the County of Riverside, the public entity which executed the foregoing notice and on whose behalf I make this verification; I have read this notice, know its contents, and the same is true. I certify under penalty of perjury that the foregoing is true and correct.

Executed at Riverside, California on 06/18/13

John J. Benoit, John J. Benoit, Chairman of the Board of Supervisors

ATTEST: Kecia Harper-Ihem, Clerk of the Board

By: Kecia Harper-Ihem Deputy

FORM APPROVED COUNTY COUNSEL

BY: Marsha L. Victor 5/23/13 updated 12/2012
MARSHA L. VICTOR DATE

06.18.13 4-2

2013-7-118852



**LARRY W. WARD
COUNTY OF RIVERSIDE
ASSESSOR-COUNTY CLERK-RECORDER**

Recorder
P.O. Box 751
Riverside, CA 92502-0751
(951) 486-7000
<http://riverside.asrec.com>

CERTIFICATION

Pursuant to the provisions of Government Code 27361.7, I certify under the penalty of perjury that the following is a true copy of illegible wording found in the attached document:

(Print or type the page number(s) and wording below):

CLARIFICATION OF THE SEAL for the Riverside County Board of Supervisors
(embossed on document)



Date: 06-18-13

Signature: *Karen Barton*

Print Name: Karen Barton, Board Assistant, Riverside County Clerk of the Board



1 AGENCY.

2 **NOW, THEREFORE**, in consideration of the foregoing and providing that all other
3 sections not amended remain intact, the parties hereto do hereby agree as follows:

4 **A.** Section 1 of the Original Agreement is hereby amended to add the following
5 sentences to the end of the current paragraph:

6 **Section 1. SCOPE OF SERVICES. . . .**

7 "CONSULTANT shall further provide services in accordance with the terms of the Third
8 Amendment as outlined and specified in Exhibit "A-3", consisting of four (4) page(s), attached
9 hereto and incorporated herein, for the purposes of CONSULTANT providing extended
10 Construction Phase Civil Engineering Services."

11 Section 1.1 shall remain unchanged.

12 **B.** Section 3 of the original Agreement is hereby amended and will read in its
13 entirety as follows:

14 **Section 3. COMPENSATION.** The AGENCY shall pay the CONSULTANT for services
15 performed and expenses incurred as follows:

16 3.1 AGENCY shall pay to Consultant for services performed and expenses incurred in
17 accordance with the Scope of Services set forth in Exhibit "A" of the Agreement dated June 23,
18 2011, Exhibit "A-1" of the First Amendment dated September 14, 2011, and Exhibit "A-2" of the
19 Second Amendment dated November 6, 2012, and Exhibit "A-3" of the Third Amendment. The
20 total amount of compensation paid to Consultant for all such services shall not exceed the sum
21 of Ninety Two Thousand Four Hundred Seventy Eight (\$92,478) dollars unless a written
22 amendment to this Agreement is executed by both parties prior to performance of additional
23 services.

24 3.2 Said compensation shall be paid in accordance with an invoice submitted to
25 AGENCY by CONSULTANT within fifteen (15) days from the last day of each calendar month,
26 and AGENCY shall pay the invoice within thirty (30) working days from the date of receipt of the
27 invoice. CONSULTANT shall invoice based on a percentage of work completed as described in
28 Exhibit "A" of the Agreement dated June 23, 2011, Exhibit "A-1" of the First Amendment dated

1 September 14, 2011, Exhibit "A-2" of the Second Amendment dated November 6, 2012, and in
2 Exhibit "A-3" of the Third Amendment.

3 **IN WITNESS WHEREOF**, the SUCCESSOR AGENCY TO THE REDEVELOPMENT
4 AGENCY FOR THE COUNTY OF RIVERSIDE, and CONSULTANT have executed this
5 Agreement as of the date first above written.

6

7 SUCCESSOR AGENCY TO THE
8 REDEVELOPMENT AGENCY FOR
9 THE COUNTY OF RIVERSIDE

ARMSTRONG & BROOKS
CONSULTING ENGINEERS

10

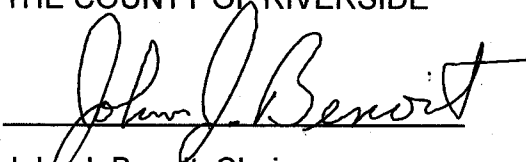

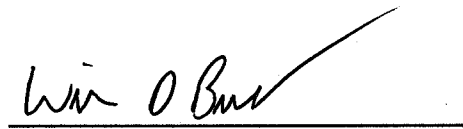

11

John J. Benoit, Chairman

William D. Brooks, Principal

12

Board of Supervisors

13

14

APPROVED AS TO FORM:

15

PAMELA J. WALLS

16

County Counsel

17

18

By:  5/28/13
Deputy

19

20

21

ATTEST:
Kecia Harper-Ihem
Clerk of the Board

22

23

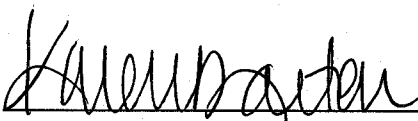
BY: 
Deputy

24

25

26

27

28

EXHIBIT "A-3"

J.N. 108.897_CS Amendment No. 3
May 2, 2013



Planning-Infrastructure-Site Development-Water Resources

Riverside County Economic Development Agency
3403 Tenth Street, Suite 500
Riverside, CA 92501

Attn: Mr. Dominick Lombardi
Facilities Project Manager III

Regarding: Proposal for Civil Engineering Services
Cabazon Civic Center – Extra Construction Support Services
Riverside County, CA – Economic Development Agency

Dear Dominick:

Armstrong & Brooks Consulting Engineers, Inc. (A&B) has provided additional construction support services exceeding the previously approved contract per Amendment No. 2. Included herewith is proposed Amendment No. 3 for additional services for on-site facilities for the Cabazon Civic Center.

On the succeeding pages of this proposal I have outlined the work included in the additional construction administration and support services. Civil engineering items included the design and construction support and construction staking for the playground shade structure, area lights, added doorway on Bldg. "A" on the northerly side, the skate park revised concrete flat work, and drainage enhancements at Bldg. "B". A&B attended several field meetings at the request of Doug Wall Construction to help facilitate and resolve site issues described above, as well as provided field engineering, technical support and design sketches for construction. Finally, we also incurred some reimbursable expenses from the dry utility subconsultant and have included those charges hereon.

The scope of work in this proposal is subject to your review and approval and any deletion or addition of line items will result in an appropriate fee adjustment.

Thank you again for this opportunity to be of service and should you have any questions or comment regarding the contents of this proposal, please do not hesitate to call. I look forward to working with you and your associates on this project.

Sincerely,

William D. Brooks, P.E.
Principal

Armstrong & Brooks Consulting Engineers
1530 Consumer Circle, Unit "B" ~ Corona, CA ~ 92880
Ph. (951) 372-8400 ~ Fax (951) 372-8430

**CABAZON CIVIC CENTER-13.6 AC+/-
Riverside County, CA – Economic Development Agency
PROPOSAL FOR CIVIL ENGINEERING – CA & CS SERVICES AMENDMENT NO. 2**

SECTION I - Scope of Work and Fees

108.897.3– Construction Administration Amendment No. 3

- 1.01 Additional Construction Staking Services.....(LS) \$ 3,850
- * Extra Staking for Site Lights on 10-15-2012, 11-16-2012 & 12-20-2012
 - * Extra Staking for seat walls and revised wall at N.E. corner Bldg A on 10-15-2012
 - * Extra Staking for Skate Park Control on 11-02-2012
 - * Extra Staking for Shade Structure East of Bldg. "A" on 11-07-2012
 - * Extra Staking for Revised grades for Path of Travel southwest of Bldg. "A"
 - * Extra Staking for seat walls on 12-29-2012
 - * Extra Staking for Shade Structure south of Library Bldg. on 1-18-2013
- 1.02 Additional Construction Engineering Support Services.....(LS) \$ 3,250
- * Engineering Design Plans and C.S. support for the playground shade structure
 - * Bldg. "A" northerly added door and ADA Path of Travel access to Bldg. & sidewalk
 - * Field meeting to resolve forming and grades for Bldg. "A", field sketches
 - * Skate park field revisions to subgrade and PCC elevations, including field meeting
 - * Drainage enhancements and Library Bldg. "B" "cobble wash" RFI 319 & 319A
- 1.03 Additional Construction Support Reimbursable Expenses.....(T&M) \$ 938
- * Dry utility sub-consultants accrued reimbursable expenses exceeding Existing contract limit

Total CA Amendment No. 3: \$ 8,038

**CABAZON CIVIC CENTER-13.6 AC+/-
Riverside County, CA – Economic Development Agency
PROPOSAL FOR CIVIL ENGINEERING – CA & CS SERVICES AMENDMENT NO. 2**

SECTION II - Exclusions and/or Conditions of Proposal

1. Incidental Expenses such as plotting, blueprinting and courier services shall be billed at cost plus 15%.
2. Owner shall be responsible for the payment of all filing, processing and permit fees required by the governing agencies.
3. Excludes field potholing of existing utilities.
4. Progress billings shall be issued monthly and be billed as a percentage complete for the first set of stakes per line items listed in the scope of work.
5. Excludes preparing and processing of an As-Built survey.
6. Excludes preparation and processing of any legal descriptions and plat maps for on-site dedications, lot line adjustments, property deeds or a Record of Survey.
7. Progress billings shall be issued monthly.

CABAZON CIVIC CENTER-13.6 AC+/-
Riverside County, CA – Economic Development Agency
PROPOSAL FOR CIVIL ENGINEERING – CA & CS SERVICES AMENDMENT NO. 2

Billing Rate Schedule
2012-2013

Professional Services ***Rate***

| | |
|--------------------------------|------------------|
| <i>Principal</i> | <i>\$165/Hr.</i> |
| <i>Civil Engineer</i> | <i>\$140/Hr.</i> |
| <i>Designer</i> | <i>\$95/Hr.</i> |
| <i>Draftsperson</i> | <i>\$80/Hr.</i> |
| <i>2 Man Survey Crew</i> | <i>\$175/Hr.</i> |

Miscellaneous Services ***Rate***

| | |
|------------------------------------|-------------------|
| <i>Travel Time</i> | <i>\$55/Hr.</i> |
| <i>Secretary</i> | <i>\$55/Hr.</i> |
| <i>Reimbursable Expenses</i> | <i>Cost + 15%</i> |

Hourly Rates are chargeable in one-quarter hour increments and are subject to change January 1, 2014

**SUCCESSOR AGENCY TO THE REDEVELOPMENT AGENCY
FOR THE COUNTY OF RIVERSIDE
CHANGE ORDER NO. 14**

Date: 2/28/2013

Project: Cabazon Civic Center

To Contractor:
Doug Wall Construction, Inc.
78450 Avenue 41
Bermuda Dunes, CA 92203

Project No: ED1308000412
Distribution:
Project Manager Construction Manager
Contractor Inspector
Fiscal Architect/Engineer

You are directed to make the following changes. Changes shall include labor, material and equipment; each item to include all charges or indirect arising out of this work:

- | | | | |
|--|-----|----|----------|
| 1) Power to irrigation controllers COR #158 | ADD | \$ | 2,648.00 |
| 2) Paint CC Restroom stalls COR #159 | ADD | \$ | 500.00 |
| 3) Adding posts to library restroom stalls COR #160 | ADD | \$ | 1,938.00 |
| 4) Dirt import at skate park COR #161 | ADD | \$ | 4,530.00 |
| 5) Rock removal COR #162 | ADD | \$ | 3,012.00 |
| 6) Plaques for A and B COR # 163 | ADD | \$ | 2,984.00 |
| 7) Library counter book drop COR # 164 | ADD | \$ | 3,028.00 |
| 8) Dewey decimal holders COR #165 | ADD | \$ | 2,909.00 |
| 9) Painting of A/C units COR #166 | ADD | \$ | 1,797.00 |
| 10) Library furniture storage costs COR #167 | ADD | \$ | 1,166.00 |
| 11) Solid surface at RR stem walls Bldg A COR #168 | ADD | \$ | 4,264.00 |
| 12) Hail Guards COR #169 | ADD | \$ | 8,983.00 |

The specifications, where pertinent, shall apply to these changes.

This Change Order provides for a time extension of 0 calendar days
Original Contract Duration (calendar days): 450
Prior Authorized Time Extension (calendar days): 110
Revised Construction Duration (calendar days): 580
Original Contract Completion Date: 10/5/2012
Revised Contract Completion Date: 1/25/2013

NOTE: This change order is not effective until ALL signatures below are obtained, and if applicable, signature authority approval by Form 11 as indicated per Change Order Guidelines.

The undersigned contractor has given careful consideration to the change proposed, including its effect on other work already contracted for, and hereby agrees, if this change order is approved, that he will provide all equipment, furnish all materials, except as may otherwise be noted above, and perform all services necessary for the work above specified, and will accept as full payment for all costs related in any way thereto the prices shown above.

1) [Signature] 3-20-13
Contractor (signature) Date

Original Contract \$ 11,990,000.00
Prior Authorized [] ADD [] DED \$ 991,432.10
Total Contract Prior to this Change \$ 12,981,432.10

[Signature]
Contractor's Printed name

Authorized Changes on this C.O.:
Addition \$ 37,759.00
Deduction \$ _____

2) [Signature]
John J. Benoit, Chairman Date
Board of Supervisors (signature)

NET: [x] Addition [] Deduction \$ 37,759.00

John J. Benoit
Chairman, Board of Supervisors
Printed name

3) [Signature] 3/20/13
Architect (signature) Date

Amount of Contract Authorized
Including this Change Order \$ 13,019,191.10

Thomas Howell
Architect's Printed name

Pursuant to:
[] Board Resolution 2012-034
[] M.O. and Date _____

ATTEST:
KECIA HARPER-IHEM, Clerk
By [Signature]
DEPUTY

4) [Signature] 3/20/13
Project Manager (signature) Date
Dominick Lombardi
Project Manager's Printed name

Successor Agency Change Order Form - Revised 07-26-12

FORM APPROVED COUNTY COUNSEL

JUN 18 2013

4-2

BY: [Signature] 5/23/13
MARSHAL VICTOR DATE



DOUG WALL CONSTRUCTION, INC.
CA SL Lic # 743112

PROPOSED CHANGE ITEM

| | |
|--------------------|----------|
| PENDING | X |
| Approved | |
| OWNER | X |
| SUBCONTRACT | |
| Internal | |

PROJECT: Cabazon Civic Center

Proposed Change Number 158

RFP #

DATE: 12/8/2012

TO: Dominick Lombardi
Tom Howell

COST CODE:

JOB # 1032

The Original Construction Agreement is hereby modified and amended by the following deviations from original plans and specifications:

Add power circuits for Bldg A, B, C, D Irrigation Controllers **\$2,485.00**

| | |
|----------------------------|-------------------|
| Subtotal | \$2,485.00 |
| Profit and Overhead 5% | \$124.00 |
| Subtotal | \$2,609.00 |
| Bonding and Insurance 1.5% | \$39.00 |
| Total | \$2,648.00 |

Original Contract Amount

| | |
|--------------------------------|----------------------------------|
| Total Previous Change Orders | _____ |
| Total Before this Change Order | _____ |
| Amount of this Change Order | Pending \$2,648.00 |
| Revised Contract Amount: | _____ |

Riverside County EDA
SIGNED: _____
DATED: _____
TITLE: _____

DOUG WALL CONSTRUCTION INC.
SIGNED: _____
DATED: _____
TITLE: _____

Architect:
SIGNED: _____
DATED: _____
TITLE: _____



CONTRACT CHANGE ORDER REQUEST

TO: Mike Glenn, Doug Wall Construction

ADDRESS: 78450 Avenue 41

Bermuda Dunes, CA 92203-1001

DATE: 11/30/12

REQUEST NO.: 037A

PROJECT: Cabazon Civic Center

PREPARED BY: Eddie Gleason

Add circuit for irrigation controller at BLDG A

Labor Electrician:

- 2 hours installation @ \$54.44 \$108.88

- 2 hours wire pull @ \$54.44 \$108.88

Material:

- Electrical Material \$36.04

O/H & P: (15% per General Conditions Article 19.1.11d1) \$38.07

Total: **\$291.87**

NOTE: The work covered by this order shall be performed under the same terms and conditions as that included in the original contract:

| | |
|--|-----------------|
| PTL ELECTRIC INC. AGREES hereby to make changes as specified above, at this price. | \$291.87 |
|--|-----------------|

ACCEPTED: The above prices and specifications of this change order are satisfactory and are hereby accepted. All work to be performed under same terms and conditions as specified in the original contract unless otherwise stipulated.

Signature: _____

Date: _____

CED - VICTORVILLE
 12137 INDUSTRIAL BLVD
 VICTORVILLE CA 92395
 TEL: 760 241-7443 FAX: 760 241-7447

CONTACT: DAVE FERRATO

QUOTE FOR: PTL ELECTRIC

ACCT #: KB-63876 CABAZON CIVIC CENTER

CABAZON CIVIC CENTER
 17205 EUCALYPTUS STREET SUITE C10
 HESPERIA, CA 92345
 TEL: (760) 244-7700

| QUOTATION | | | Page 001 OF 001 | |
|----------------|----------|-------------|-----------------|--|
| QUOTE # | Date | Rev # | Rev Date | |
| 1008954 | 11/21/12 | 000 | 11/21/12 | |
| QUOTE EXPIRES | | PREPARED BY | | |
| 12/21/2012 | | DAVE | | |
| SLS | | INSL | | |
| 0138 | | 0138 | | |
| FOB | | FREIGHT | | |
| SHIPPING POINT | | PREPAID | | |

| |
|---------------------------|
| CLIENT PO #: |
| JOB NAME: |
| BLDG A IRRIGATION CONTROL |

| LN | QTY | MFR | CATALOG # | DESCRIPTION | PRICE | LOM | EXT AMT |
|----|-----|------|--------------|--------------|--------|-----|------------|
| 01 | 30 | PVC | COND-3/4 | CONDUIT | 20.12 | C | 6.04 |
| 02 | 100 | WIRE | TRHNI0STRBLK | * | 239.84 | M | 23.98 |
| 03 | 2 | PVC | CPL2 | CONDUIT CPLG | 85.54 | C | 1.71 |
| 04 | 2 | PVC | EL-3/4 | ELBOW | 86.00 | C | 1.72 |

MDSE: 33.45

TAX: 2.59

TOTAL: 36.04

PLEASE NOTE: THIS IS NOT AN OFFER TO CONTRACT, BUT MERELY A QUOTATION OF CURRENT PRICES FOR YOUR CONVENIENCE AND INFORMATION. ORDERS BASED ON THIS QUOTATION ARE SUBJECT TO YOUR ACCEPTANCE OF THE TERMS AND CONDITIONS STATED IN OUR WRITTEN ACKNOWLEDGEMENT OF ORDER. WE MAKE NO REPRESENTATION WITH RESPECT TO COMPLIANCE WITH JOB SPECIFICATIONS.



17205 Eucalyptus St. Suite C-10 Hesperia, CA 92345
Office (760)244-7700 Fax (760)244-5800

CONTRACT CHANGE ORDER REQUEST

TO: Mike Glenn, Doug Wall Construction

ADDRESS: 78450 Avenue 41

Bermuda Dunes, CA 92203-1001

DATE: 11/30/12

REQUEST NO.: 037B

PROJECT: Cabazon Civic Center

PREPARED BY: Eddie Gleason

Add circuit for irrigation controller at BLDG B

Labor Electrician:

- 3 hours installation @ \$54.44 \$163.32

- 3 hours wire pull @ \$54.44 \$163.32

Material:

- Electrical Material \$31.94

O/H & P: (15% per General Conditions Article 19.1.11d1) \$53.79

Total: \$412.37

NOTE: The work covered by this order shall be performed under the same terms and conditions as that included in the original contract:

PTL ELECTRIC INC. AGREES hereby to make changes as specified above, at this price. **\$412.37**

ACCEPTED: The above prices and specifications of this change order are satisfactory and are hereby accepted. All work to be performed under same terms and conditions as specified in the original contract unless otherwise stipulated.

Signature: _____

Date: _____

CED - VICTORVILLE
 12137 INDUSTRIAL BLVD
 VICTORVILLE CA 92395
 TEL: 760 241-7443 FAX: 760 241-7447

CONTACT: DAVE FERRATO

QUOTE FOR: PTL ELECTRIC
 ACCT #: KB-63876 CABAZON CIVIC CENTER

CABAZON CIVIC CENTER
 17205 EUCALYPTUS STREET SUITE C10
 HESPERIA, CA 92345
 TEL: (760) 244-7700

| QUOTATION | | | Page |
|----------------|----------|-------------|------------|
| QUOTE # | Date | Rev # | 001 OF 001 |
| 1008954 | 11/21/12 | 001 | 11/21/12 |
| QUOTE EXPIRES | | PREPARED BY | |
| 12/21/2012 | | DAVE | |
| SIS | | INSL | |
| 0138 | | 0138 | |
| FOB | | FREIGHT | |
| SHIPPING POINT | | PREPAID | |

| |
|---------------------------|
| CUSPO#: |
| JOB NAME: |
| BLDG B IRRIGATION CONTROL |

| LN | QTY | MFR | CATALOG # | DESCRIPTION | PRICE | UOM | EXT AMT |
|----|-----|------|--------------|---------------------------|--------|-----|---------|
| 01 | 10 | GAL | COND-3/4 | GALV STEEL | 198.85 | C | 19.89 |
| 02 | 50 | WIRE | TRHN1280LBLK | * | 133.88 | M | 6.69 |
| 03 | 1 | BWP | B5V | 1G WP GRY BOX W/3-1/2HUBS | 2.30 | E | 2.30 |
| 04 | 1 | BWP | BC1V | 1G WP GRY BLANK COVER | 0.76 | E | .76 |

MDSE: 29.64
 TAX: 2.30
 TOTAL: 31.94

PLEASE NOTE: THIS IS NOT AN OFFER TO CONTRACT, BUT MERELY A QUOTATION OF CURRENT PRICES FOR YOUR CONVENIENCE AND INFORMATION. ORDERS BASED ON THIS QUOTATION ARE SUBJECT TO YOUR ACCEPTANCE OF THE TERMS AND CONDITIONS STATED IN OUR WRITTEN ACKNOWLEDGEMENT OF ORDER. WE MAKE NO REPRESENTATION WITH RESPECT TO COMPLIANCE WITH JOB SPECIFICATIONS.



CONTRACT CHANGE ORDER REQUEST

TO: Mike Glenn, Doug Wall Construction
 ADDRESS: 78450 Avenue 41
 Bermuda Dunes, CA 92203-1001

DATE: 11/30/12
 REQUEST NO.: 037C
 PROJECT: Cabazon Civic Center
 PREPARED BY: Eddie Gleason

Add circuit for irrigation controller at BLDG C.

| | |
|--|-----------------|
| Labor Electrician: | |
| - 1 hours installation @ \$54.44 | \$54.44 |
| - 1 hours wire pull @ \$54.44 | \$54.44 |
| - 2 hours excavation @ \$54.44 | \$108.88 |
| - 2 hours backfill @ \$54.44 | \$108.88 |
| Labor Operator: | |
| - 2 hours excavation @ \$59.75 | \$119.50 |
| - 2 hours backfill @ \$59.75 | \$119.50 |
| Material: | |
| - Electrical Material | \$200.12 |
| Equipment: | |
| - 4 hours @ \$20.63 | \$82.52 |
| O/H & P: (15% per General Conditions Article 19.1.11d1) | \$127.24 |
| Total: | \$975.50 |

NOTE: The work covered by this order shall be performed under the same terms and conditions as that included in the original contract:

PTL ELECTRIC INC. AGREES hereby to make changes as specified above, at this price. **\$975.50**

ACCEPTED: The above prices and specifications of this change order are satisfactory and are hereby accepted. All work to be performed under same terms and conditions as specified in the original contract unless otherwise stipulated.

Signature: _____ Date: _____

CED - VICTORVILLE
 12137 INDUSTRIAL BLVD
 VICTORVILLE CA 92395
 TEL: 760 241-7443 FAX: 760 241-7447

CONTACT: DAVE FERRATO

QUOTE FOR: PTL ELECTRIC

ACCT #: KB-63876 CABAZON CIVIC CENTER

CABAZON CIVIC CENTER
 17285 EUCALYPTUS STREET SUITE C10
 HESPERIA, CA 92345
 TEL: (760) 244-7700

| QUOTATION | | | Page |
|----------------|----------|-------------|------------|
| QUOTE # | Date | Rev # | 001 OF 001 |
| 1008954 | 11/21/12 | 003 | 11/21/12 |
| QUOTE EXPIRES | | PREPARED BY | |
| 12/21/2012 | | DAVE | |
| SLS | | INSL | |
| 0138 | | 0138 | |
| FOB | | FREIGHT | |
| SHIPPING POINT | | PREPAID | |

| |
|---------------------------|
| CUS PO #: |
| JOB NAME: |
| BLDG C IRRIGATION CONTROL |

| LN | QTY | MFR | CATALOG # | DESCRIPTION | PRICE | COM | EXT AMT |
|----|-----|------|--------------|--------------|--------|-----|---------|
| 01 | 180 | PVC | COND-3/4 | CONDUIT | 21.61 | C | 38.90 |
| 02 | 2 | PVC | CPL-3/4 | CONDUIT CPLG | 38.80 | C | .78 |
| 03 | 2 | PVC | EL-3/4 | ELBOW | 107.51 | C | 2.15 |
| 04 | 600 | WIRE | THEMIOSTRBLK | * | 239.84 | M | 143.90 |

MDSE: 185.73
 TAX: 14.39
 TOTAL: 200.12

PLEASE NOTE: THIS IS NOT AN OFFER TO CONTRACT, BUT MERELY A QUOTATION OF CURRENT PRICES FOR YOUR CONVENIENCE AND INFORMATION. ORDERS BASED ON THIS QUOTATION ARE SUBJECT TO YOUR ACCEPTANCE OF THE TERMS AND CONDITIONS STATED IN OUR WRITTEN ACKNOWLEDGEMENT OF ORDER. WE MAKE NO REPRESENTATION WITH RESPECT TO COMPLIANCE WITH JOB SPECIFICATIONS.



17205 Eucalyptus St. Suite C-10 Hesperia, CA 92345
Office (760)244-7700 Fax (760)244-5800

CONTRACT CHANGE ORDER REQUEST

TO: Mike Glenn, Doug Wall Construction
ADDRESS: 78450 Avenue 41
Bermuda Dunes, CA 92203-1001

DATE: 11/30/12
REQUEST NO.: 037D
PROJECT: Cabazon Civic Center
PREPARED BY: Eddie Gleason

Add circuit for irrigation controller at BLDG D.

Labor Electrician:

| | |
|----------------------------------|----------|
| - 1 hours installation @ \$54.44 | \$54.44 |
| - 1 hours wire pull @ \$54.44 | \$54.44 |
| - 2 hours excavation @ \$54.44 | \$108.88 |
| - 2 hours backfill @ \$54.44 | \$108.88 |

Labor Operator:

| | |
|--------------------------------|----------|
| - 2 hours excavation @ \$59.75 | \$119.50 |
| - 2 hours backfill @ \$59.75 | \$119.50 |

Material:

| | |
|-----------------------|---------|
| - Electrical Material | \$49.75 |
|-----------------------|---------|

Equipment:

| | |
|---------------------|---------|
| - 4 hours @ \$20.63 | \$82.52 |
|---------------------|---------|

| | |
|---|----------|
| O/H & P: (15% per General Conditions Article 19.1.11d1) | \$104.68 |
|---|----------|

| | |
|---------------|-----------------|
| Total: | \$804.59 |
|---------------|-----------------|

NOTE: The work covered by this order shall be performed under the same terms and conditions as that included in the original contract.

PTL ELECTRIC INC. AGREES hereby to make changes as specified above, at this price. **\$804.59**

ACCEPTED: The above prices and specifications of this change order are satisfactory and are hereby accepted. All work to be performed under same terms and conditions as specified in the original contract unless otherwise stipulated.

Signature: _____

Date: _____

CED - VICTORVILLE
 12137 INDUSTRIAL BLVD
 VICTORVILLE CA 92395
 TEL: 760 241-7443 FAX: 760 241-7447

CONTACT: DAVE FERRATO

QUOTE FOR: PTL ELECTRIC

ACCT #: KB-63876 CABAZON CIVIC CENTER

CABAZON CIVIC CENTER
 17205 EUCALYPTUS STREET SUITE C10
 HESPERIA, CA 92345
 TEL: (760) 244-7700

| QUOTATION | | | Page |
|----------------|----------|-------------|------------|
| QUOTE # | Date | Rev # | 001 OF 001 |
| 1008954 | 11/21/12 | 002 | 11/21/12 |
| QUOTE EXPIRES | | PREPARED BY | |
| 12/21/2012 | | DAVE | |
| SLS | | INSL | |
| 0138 | | 0138 | |
| FOB | | FREIGHT | |
| SHIPPING POINT | | PREPAID | |

| |
|--|
| CUS PO #: |
| JOB NAME: BLDG D IRRIGATION CONTROL |

| LN | QTY | MFR | CATALOG # | DESCRIPTION | PRICE | LOM | EXT AMT |
|----|-----|------|--------------|--------------|--------|-----|---------|
| 01 | 70 | PVC | COND-3/4 | CONDUIT | 21.61 | C | 15.13 |
| 02 | 2 | PVC | CPL-3/4 | CONDUIT CPLG | 39.80 | C | .78 |
| 03 | 2 | PVC | EL-3/4 | ELBOW | 107.51 | C | 2.15 |
| 04 | 210 | WIRE | THRN12SOLBLK | * | 133.88 | M | 28.11 |

MIDSE: 46.17
 TAX: 3.58
 TOTAL: 49.75

PLEASE NOTE: THIS IS NOT AN OFFER TO CONTRACT, BUT MERELY A QUOTATION OF CURRENT PRICES FOR YOUR CONVENIENCE AND INFORMATION. ORDERS BASED ON THIS QUOTATION ARE SUBJECT TO YOUR ACCEPTANCE OF THE TERMS AND CONDITIONS STATED IN OUR WRITTEN ACKNOWLEDGEMENT OF ORDER. WE MAKE NO REPRESENTATION WITH RESPECT TO COMPLIANCE WITH JOB SPECIFICATIONS.



DOUG WALL CONSTRUCTION, INC.
CA SL LK # 743112

PROPOSED CHANGE ITEM

| | |
|--------------------|----------|
| PENDING | X |
| Approved | |
| OWNER | X |
| SUBCONTRACT | |
| Internal | |

PROJECT: Cabazon Civic Center

Proposed Change Number 159

RFP #

DATE: 12/9/2012

TO: Dominick Lombardi
Tom Howell

COST CODE:

JOB # 1032

The Original Construction Agreement is hereby modified and amended by the following deviations from original plans and specifications:

Paint/Labor/Color Match/Travel Time to Paint Community Center Bathroom Stalls **\$500.00**

| | |
|----------------------------|-----------------|
| Subtotal | \$500.00 |
| Profit and Overhead 5% | |
| Subtotal | |
| Bonding and Insurance 1.5% | |
| Total | |

Original Contract Amount
 Total Previous Change Orders
 Total Before this Change Order
 Amount of this Change Order
 Revised Contract Amount:

Pending

| |
|-----------------|
| _____ |
| _____ |
| _____ |
| \$500.00 |
| _____ |

Riverside County EDA
SIGNED: _____
DATED: _____
TITLE: _____

DOUG WALL CONSTRUCTION INC.
SIGNED: _____
DATED: _____
TITLE: _____

Architect:
SIGNED: _____
DATED: _____
TITLE: _____



DOUG WALL CONSTRUCTION, INC.
CA SL LK 9 14012

PROPOSED CHANGE ITEM

| | |
|--------------------|----------|
| PENDING | X |
| Approved | |
| OWNER | X |
| SUBCONTRACT | |
| Internal | |

PROJECT: Cabazon Civic Center

Proposed Change Number 160

RFP #

DATE: 12/12/2012

TO: Dominick Lombardi
Tom Howell

COST CODE:

JOB # 1032

The Original Construction Agreement is hereby modified and amended by the following deviations from original plans and specifications:

| | |
|---|-------------------|
| Add Aluminum Posts to Library Stalls | \$1,318.00 |
| Added Framing at Ceiling | \$200.00 |
| Drywall Repair/Paint | \$300.00 |

| | |
|----------------------------|-------------------|
| Subtotal | \$1,818.00 |
| Profit and Overhead 5% | \$91.00 |
| Subtotal | \$1,909.00 |
| Bonding and Insurance 1.5% | \$29.00 |
| Total | \$1,938.00 |

| | |
|--------------------------------|----------------------|
| Original Contract Amount | _____ |
| Total Previous Change Orders | _____ |
| Total Before this Change Order | _____ |
| Amount of this Change Order | Pending _____ |
| Revised Contract Amount | _____ |

Riverside County EDA
SIGNED: _____
DATED: _____
TITLE: _____

DOUG WALL CONSTRUCTION INC.
SIGNED: _____
DATED: _____
TITLE: _____

Architect: _____
SIGNED: _____
DATED: _____
TITLE: _____



REQUEST FOR CHANGE ORDER

CONTRACTOR: DOUG WALL CONSTRUCTION DATE: 12/11/12

ATTENTION: MIKE GLENN JOB: CABAZON CIVIC CENTER

GLOBAL JOB#: 11284 CHANGE ORDER: 6

REASON FOR CHANGE:

ADD STABILITY TO FLOOR MOUNTED TOILET PARTITIONS.

MATERIAL REQUESTED:

ADD FOR EACH POST: \$659.00 EACH

******SEE ATTACHED DRAWING**

**TOTAL COST INCLUDING TAX
LABOR
TOTAL CHANGE ORDER REQUEST**

**\$SEE ABOVE
INCLUDED
\$SEE ABOVE**

GLOBAL SPECIALTIES DIRECT INC

ACCEPTED BY: _____

**BY: CORY AVILA
PROJECT MANAGER**

TITLE: _____

**PLEASE NOTE: CHANGE ORDER
WILL NOT BE PROCESSED UNTIL
SIGNATURE IS RECEIVED**

****CHANGE ORDER(S) WILL NOT BE PROCESSED
UNTIL GLOBAL SPECIALTIES DIRECT INC HAS
RECEIVED APPROVAL FROM YOUR FIRM.**

**10118 SANTA FE SPRINGS RD, SANTA FE SPRINGS, CA 90670
PHONE (562) 777-1170 • FAX (562) 777-1169**

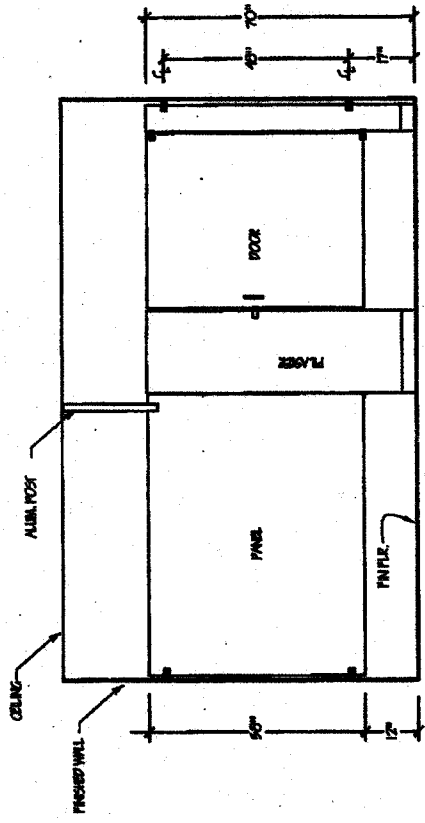

CAPAZON CIVIC CENTER
 DOUG WALL CONSTRUCTION
 REF: TOILET PARTITIONS STABILITY OPTION

ADEQUATE BACKING MUST BE PROVIDED BY OTHERS AT ALL CONNECTING POINTS.

SCALE: NTS





DOUG WALL CONSTRUCTION, INC.
CA SL Lic # 243112

PROPOSED CHANGE ITEM

| | |
|-------------|---|
| PENDING | X |
| Approved | |
| OWNER | X |
| SUBCONTRACT | |
| Internal | |

PROJECT: Cabazon Civic Center

Proposed Change Number 160

RFP #

DATE: 12/13/2012

TO: Dominick Lombardi
Tom Howell

COST CODE:

JOB # 1032

The Original Construction Agreement is hereby modified and amended by the following deviations from original plans and specifications:

Import for Skate Park and West Parking Area North of Bldg C \$4,250.00

| | |
|----------------------------|------------|
| Subtotal | \$4,250.00 |
| Profit and Overhead 5% | \$213.00 |
| Subtotal | \$4,463.00 |
| Bonding and Insurance 1.5% | \$67.00 |
| Total | \$4,530.00 |

Original Contract Amount
Total Previous Change Orders
Total Before this Change Order
Amount of this Change Order
Revised Contract Amount

Pending

\$4,530.00

Riverside County EDA
SIGNED: _____
DATED: _____
TITLE: _____

DOUG WALL CONSTRUCTION INC.
SIGNED: _____
DATED: _____
TITLE: _____

Architect:
SIGNED: _____
DATED: _____
TITLE: _____



12831 Moreno Beach Dr. #107-181
 Moreno Valley, Ca 92555

Invoice

| Date | Invoice # |
|-----------|-----------|
| 12-5-2012 | 3140-180 |

Bill To
 Doug Wall
 78450 Ave. 41
 Bermuda Dunes, Ca. 92203

| | | P.O. No. | Terms | |
|----------|---|--------------|-------------------|--|
| | | Net 30 | | |
| Quantity | Description | Rate | Amount | |
| | Cabazon Civic Center | | | |
| | Import for Skate Park/West Parking Lot | | | |
| 20 | Loads at \$85.00/Load at Skate Park | \$85.00 | \$1,700.00 | |
| 30 | Loads at \$85.00/Load at West Parking Lot | \$85.00 | \$2,550.00 | |
| | | Total | \$4,250.00 | |



DOUG WALL CONSTRUCTION, INC.
CA St. Lic # 743112

PROPOSED CHANGE ITEM

| | |
|-------------|---|
| PENDING | X |
| Approved | |
| OWNER | X |
| SUBCONTRACT | |
| Internal | |

PROJECT: Cabazon Civic Center

Proposed Change Number 162

RFP #

DATE: 12/13/2012

TO: Dominick Lombardi
Tom Howell

COST CODE:

JOB # 1032

The Original Construction Agreement is hereby modified and amended by the following deviations from original plans and specifications:

T&M Rock Removal for 12-6-12 \$2,920.00

| | |
|----------------------------|------------|
| Subtotal | \$2,920.00 |
| Profit and Overhead 5% | \$146.00 |
| Subtotal | \$3,066.00 |
| Bonding and Insurance 1.5% | \$46.00 |
| Total | \$3,012.00 |

Original Contract Amount
Total Previous Change Orders
Total Before this Change Order
Amount of this Change Order
Revised Contract Amount:

Pending

\$3,012.00

Riverside County EDA
SIGNED: _____
DATED: _____
TITLE: _____

DOUG WALL CONSTRUCTION INC.
SIGNED: _____
DATED: _____
TITLE: _____

Architect:
SIGNED: _____
DATED: _____
TITLE: _____



12831 Moreno Beach Dr. #107-181
 Moreno Valley, Ca 92555

Invoice

| | |
|------------|-----------|
| Date | Invoice # |
| 12/11/2012 | 3140-183 |

Bill To
 Doug Wall
 78450 Ave. 41
 Bermuda Dunes, Ca. 92203

| | | P.O. No. Project/Job | Terms | |
|----------|--|-------------------------|----------------|----------------------|
| | | 1032 Cabazon | Due on receipt | Cabazon Civic Center |
| Quantity | Description | Rate | Amount | |
| | Cabazon Civic Center | | | |
| | One Day T&M Work 1 2-6-12 removing over sized rocks | | | |
| 8 | 8 hours 950 Loader \$ 145.00 an hour | 145.00 | | 1,160.00 |
| 8 | 8 hours Bobcat \$ 95.00 an hou | 95.00 | | 760.00 |
| 8 | 8 hours Bobtail Dump Truck \$ 85.00 an hour | 85.00 | | 680.00 |
| 8 | 8 Dump Truck Fees at \$ 40.00 a load | 95.00 | | 380.00 |
| | | 40.00 | | 320.00 |
| | | Total | | \$2,920.00 |

Riverside County, RDA
Cabazon Civic Center

DAILY FORCE ACCOUNT REPORT

REPORT NO. : 1032-12-6-1 Project No. ED13080004
 CONTRACTOR: DWC DATE: 12-6-12
 SUBCONTRACTOR: DEPENDABLE CONTRACTORS
 DESCRIPTION OF WORK: DEE EXCAVATION / GRADING / MISC
 FIELD DIRECTIVE NO. : 3 RFP NO. _____

| LABOR | NAME/TRADE | HOURS |
|-----------------------------------|--------------|-------|
| | | |
| | | |
| | | |
| | | |
| | | |
| | | |
| | | |
| | | |
| | | |
| | | |
| EQUIPMENT (Make, Model, Capacity) | | HOURS |
| | 950 Loader & | 8 |
| | Bobcat | 8 |
| | Dump Truck | 8 |
| | | |
| | | |
| | | |
| | | |
| | | |
| | | |
| MATERIAL (Invoice Attached) | | |
| | | |
| | | |
| | | |
| | | |
| | | |
| | | |

THE ABOVE WORK WAS PERFORMED BY THE CONTRACTOR/SUBCONTRACTOR IN COMPLIANCE WITH THE GENERAL CONDITIONS OF THE CONTRACT.

CONTRACTOR: Jm Ge DATE: 12-6-12
 MTGL INSPECTOR: _____ DATE: _____



DOUG WALL CONSTRUCTION, INC.
CA SL LK 7 74012

PROPOSED CHANGE ITEM

| | |
|--------------------|----------|
| PENDING | X |
| Approved | |
| OWNER | X |
| SUBCONTRACT | |
| Internal | |

PROJECT: Cabazon Civic Center

Proposed Change Number 163

RFP #

DATE: 12/13/2012

TO: Dominick Lombardi
Tom Howell

COST CODE:

JOB # 1032

The Original Construction Agreement is hereby modified and amended by the following deviations from original plans and specifications:

Add Dedication Plaques (2) \$2,800.00

| | |
|----------------------------|-------------------|
| Subtotal | \$2,800.00 |
| Profit and Overhead 5% | \$140.00 |
| Subtotal | \$2,940.00 |
| Bonding and Insurance 1.5% | \$44.00 |
| Total | \$2,984.00 |

Original Contract Amount
 Total Previous Change Orders
 Total Before this Change Order
 Amount of this Change Order
 Revised Contract Amount:

Pending

\$2,984.00

Riverside County EDA
 SIGNED: _____
 DATED: _____
 TITLE: _____

DOUG WALL CONSTRUCTION INC.
 SIGNED: _____
 DATED: _____
 TITLE: _____

Architect:
 SIGNED: _____
 DATED: _____
 TITLE: _____



SIGN SOLUTIONS

WWW.SO CALSIGN SOLUTIONS.COM LICENSE #: 968932
5637 ARROW HWY., SUITE H • MONTCLAR, CA • 91763
"SIGNS WITHOUT LIMITS"

- ARCHITECTURAL SIGNS
- DESIGNERS
- MANUFACTURERS
- CONSULTANTS

P: 909-628-7660
F: 909-628-7664

Estimate

| Date | Estimate # |
|------------|------------|
| 12/12/2012 | 817 |

| Name / Address |
|---|
| Doug Wall Construction, Inc. 78450 Ave 41 Bermuda Dunes, CA 92203 |

| Ship To |
|----------------------|
| Cabazon Civic Center |

| P.O. No. | Terms | Rep | Project |
|----------|----------|------|---------|
| | Contract | Haji | |

| Item | Description | Qty | Cost | Total |
|---|---|-----|--------------|------------|
| Bronze Plaque | Fabricate Bronze Dedication Plaque 14" X 22" with Etched Raised and Recessed Graphics- Art work to follow after NTP | 2 | 1,250.00 | 2,500.00 |
| Install | Installation Charges | | 300.00 | 300.00 |
| Thank you for the opportunity to provide you with the estimate you requested. | | | Total | \$2,800.00 |

Customer Signature _____



DOUG WALL CONSTRUCTION, INC.
CA St. Lic # 943112

PROPOSED CHANGE ITEM

| | |
|-------------|---|
| PENDING | X |
| Approved | |
| OWNER | X |
| SUBCONTRACT | |
| Internal | |

PROJECT: Cabazon Civic Center

Proposed Change Number 164

RFP #

DATE: 12/14/2012

TO: Dominick Lombardi
Tom Howell

COST CODE:

JOB # 1032

The Original Construction Agreement is hereby modified and amended by the following deviations from original plans and specifications:

| | |
|---|------------|
| Cut Hole in Countertop for Book Drop/Frame and Relaminate Counter Front | \$2,735.00 |
| Add Stainless Steel Liner for Book Drop | \$200.00 |

| | |
|----------------------------|------------|
| Subtotal | \$2,935.00 |
| Profit and Overhead 5% | \$147.00 |
| Subtotal | \$3,082.00 |
| Bonding and Insurance 1.5% | \$46.00 |
| Total | \$3,028.00 |

| | |
|--------------------------------|---------------|
| Original Contract Amount | _____ |
| Total Previous Change Orders | _____ |
| Total Before this Change Order | _____ |
| Amount of this Change Order | Pending _____ |
| Revised Contract Amount: | \$3,028.00 |

Riverside County EDA
 SIGNED: _____
 DATED: _____
 TITLE: _____

DOUG WALL CONSTRUCTION INC.
 SIGNED: _____
 DATED: _____
 TITLE: _____

Architect:
 SIGNED: _____
 DATED: _____
 TITLE: _____

David M. Bertino, Mfg. Inc.

Contractor License #520857 - Woodwork Institute #406

DATE: December 12, 2012

1696 W. Mill St., units 21-22
Colton, CA. 92324
Phone (909) 888-9122 Fax (909) 381-5577

Attn: Mike Glenn
Doug Wall Construction, Inc.
78450 Avenue 41
Bermuda Dunes, CA 92203
(PH) (760) 772-8446 (Fax) (760) 772-9407

Prepared by: John Parkes

Proposed Change Order for Library

| |
|--|
| <p>JOB NAME: Cabazon Civic Center</p> <p>Our Job #6058</p> <p>Proposed cost to fill in the front book drop and re skin the entire front panel and cut in a new book drop in the countertop. Doug Wall Construction will provide a stainless steel grommet to trim out the book drop hole.</p> <p>TOTAL for this Proposed Change Order is an ADD of \$2,735.00</p> <p>We will not proceed until we receive a signed Change Order from you.</p> |
|--|

RE: Cabazon Civic Center - Library

From: "Lombardi, Dominick" <DLOMBARDI@rivcoeda.org>
To: 'Mike Glenn', tom howell, "Frost, Andrew"
Subject: RE: Cabazon Civic Center - Library
Date: Dec 13, 2012 4:07 PM

Mike,

Please proceed with this.

From: Mike Glenn [mailto:sooner56@earthlink.net]
Sent: Wednesday, December 12, 2012 8:43 AM
To: tom howell; Lombardi, Dominick; Frost, Andrew
Subject: Fw: Cabazon Civic Center - Library

Good Morning,
Please see the attached proposal. How do you want to proceed?

-----Forwarded Message-----

From: John Parkes
Sent: Dec 12, 2012 8:50 AM
To: Mike Glenn
Subject: Cabazon Civic Center - Library

Hi Mike,
Here is my proposed change order for the Library.
Please let me know if you need anything else.

Thanks,
John

John Parkes
Estimating

David M Bertino Manufacturing
1696 West Mill, Units 21,22
Colton, CA 92324
PH (909) 888-9122 FX (909) 381-5577
E-mail: jparkes@davidmbertinomanufacturing.com

Lic. No. 520857

DWC

DOUG WALL CONSTRUCTION, INC.
CA 5116070112

PROPOSED CHANGE ITEM

| | |
|-------------|---|
| PENDING | X |
| Approved | |
| OWNER | X |
| SUBCONTRACT | |
| Internal | |

PROJECT: Cabazon Civic Center

Proposed Change Number 165

RFP #

DATE: 12/19/2012

TO: Dominick Lombardi
Tom Howell

COST CODE:

JOB # 1032

The Original Construction Agreement is hereby modified and amended by the following deviations from original plans and specifications:

Add Blank Paper Holders 8" X 8" x 1/4" per attached proposal \$2,730.00

| | |
|----------------------------|------------|
| Subtotal | \$2,730.00 |
| Profit and Overhead 5% | \$137.00 |
| Subtotal | \$2,866.00 |
| Bonding and Insurance 1.5% | \$43.00 |
| Total | \$2,909.00 |

| | |
|--------------------------------|------------|
| Original Contract Amount | _____ |
| Total Previous Change Orders | _____ |
| Total Before this Change Order | _____ |
| Amount of this Change Order | Pending |
| Revised Contract Amount: | \$2,909.00 |

Riverside County EDA
 SIGNED: _____
 DATED: _____
 TITLE: _____

DOUG WALL CONSTRUCTION INC.
 SIGNED: _____
 DATED: _____
 TITLE: _____

Architect:
 SIGNED: _____
 DATED: _____
 TITLE: _____



SIGN SOLUTIONS

WWW.SOCALSIGNSOLUTIONS.COM LICENSE # 968932
5637 ARROW HWY., SUITE H • MONTCLAIR, CA • 91763
"SIGNS WITHOUT LIMITS"

- ARCHITECTURAL SIGNS
- DESIGNERS
- MANUFACTURERS
- CONSULTANTS

P: 909-628-7660
F: 909-628-7664

Estimate

| Date | Estimate # |
|------------|------------|
| 12/17/2012 | 818 |

| Name / Address |
|---|
| Doug Wall Construction, Inc. 78450 Ave 41 Bermuda Dunes, CA 92203 |

| Ship To |
|----------------------|
| Cabazon Civic Center |

| P.O. No. | Terms | Rep | Project |
|----------|----------|------|---------|
| | Contract | Haji | |

| Item | Description | Qty | Cost | Total |
|---|---|-----|--------------|------------|
| Signage | Fabricate Custom Blank Paper Holder 8" X 8" X 1/4" with 1/2" thick Brushed Aluminum Stand offs | 28 | 85.00 | 2,380.00 |
| Install | Installation Charges | | 350.00 | 350.00 |
| Thank you for the opportunity to provide you with the estimate you requested. | | | Total | \$2,730.00 |

Customer Signature _____



DOUG WALL CONSTRUCTION, INC.
CA SL L& # 743112

| | |
|--------------------|----------|
| PENDING | X |
| Approved | |
| OWNER | X |
| SUBCONTRACT | |
| Internal | |

PROPOSED CHANGE ITEM

PROJECT: Cabazon Civic Center

Proposed Change Number 166

RFP #

DATE: 12/20/2012

TO: Dominick Lombardi
Tom Howell

COST CODE:

JOB # 1032

The Original Construction Agreement is hereby modified and amended by the following deviations from original plans and specifications:

Paint A/C Units (Bldg A/B/C) **\$1,687.00**

| | |
|----------------------------|-------------------|
| Subtotal | \$1,687.00 |
| Profit and Overhead 5% | \$84.00 |
| Subtotal | \$1,771.00 |
| Bonding and Insurance 1.5% | \$26.00 |
| Total | \$1,797.00 |

Original Contract Amount

| | |
|--------------------------------|----------------------|
| Total Previous Change Orders | _____ |
| Total Before this Change Order | _____ |
| Amount of this Change Order | Pending _____ |
| Revised Contract Amount: | \$1,797.00 |

Riverside County EDA
SIGNED: _____
DATED: _____
TITLE: _____

DOUG WALL CONSTRUCTION INC.
SIGNED: _____
DATED: _____
TITLE: _____

Architect:
SIGNED: _____
DATED: _____
TITLE: _____



Moreno and Sons Painting, Inc.

75735 Ramon Road
Thousand Palms, Ca 92276
760-343-3141
Fax-760-343-2062

| Date | Estimate # |
|------------|------------|
| 12/19/2012 | 12-772 |

| |
|--|
| CA Lic #354911 Classification B,C9,C33 |
| Name / Address |
| Doug Wall Construction Inc. 78-450 Avenue 41 Bermuda Dunes, CA 92203 |

| |
|-----------------|
| Project |
| Cabazon Civi... |

| Description | Cost | Total |
|---|--------------|-------------------|
| <p>We are pleased to submit our proposal for painting of the above referenced project as descibed below: This proposal is based solely upon the particular drawings, specifications and other contract documents listed and further designations, clarifications stated and qualifications stated by Moreno And Sons Painting, Inc.</p> <p>Scope of Work includes:</p> <p>EXTRA-Prime and paint 11 air condition units on buildings A, B, and C</p> | 1,687.00 | 1,687.00 |
| <p>All invoices are due upon completion of the work.</p> <p>Thank you for the opportunity, we look forward to serving you.</p> | Total | \$1,687.00 |



DOUG WALL CONSTRUCTION, INC.
CAS LICENSE # 45112

| | |
|-------------|---|
| PENDING | X |
| Approved | |
| OWNER | X |
| SUBCONTRACT | |
| Internal | |

PROPOSED CHANGE ITEM

PROJECT: Cabazon Civic Center

Proposed Change Number 167

RFP #

DATE: 12/29/2012

TO: Dominick Lombardi
Tom Howell

COST CODE:

JOB # 1032

The Original Construction Agreement is hereby modified and amended by the following deviations from original plans and specifications.

Storage Costs for Library Furniture **\$1,166.00**

| | |
|----------------------------|-------------------|
| Subtotal | \$1,166.00 |
| Profit and Overhead 5% | |
| Subtotal | \$1,166.00 |
| Bonding and Insurance 1.5% | |
| Total | \$1,166.00 |

| | |
|--------------------------------|--|
| Original Contract Amount | _____ |
| Total Previous Change Orders | _____ |
| Total Before this Change Order | _____ |
| Amount of this Change Order | Pending <u> \$1,166.00 </u> |
| Revised Contract Amount: | _____ |

Riverside County EDA
SIGNED: _____
DATED: _____
TITLE: _____

DOUG WALL CONSTRUCTION INC.
SIGNED: _____
DATED: _____
TITLE: _____

Architect:
SIGNED: _____
DATED: _____
TITLE: _____



16552 Burke Lane, Huntington Beach, CA 92647-4538
 (714) 843-9882 • (800) 444-4594 • FAX (714) 843-9202

To: Doug Wall Construction, Inc.

Date: 12/19/2012
 Job Location: Cabazon Civic Center

Attn: Mike Glenn

| ITEM | QTY. | PART NO. | DESCRIPTION | UNIT PRICE | EXTENSION |
|--|------|----------|---|------------|--------------------|
| Change Order Proposal #1 | | | | | |
| 1. | 1 | | Pro-rated storage charges of \$400/month for library furniture from 12/1/2012 - 1/4/2013. Manufacturer: The Worden Company | 452.00 | \$ 452.00 |
| 2. | 1 | | Pro-rated storage charges of \$260/month for library furniture from 12/12/2012 - 1/8/2013. Manufacturer: Arcadia Chair | 235.00 | \$ 235.00 |
| | 1 | | Delivery Charges | 290.00 | \$ 290.00 |
| 3. | 1 | | Pro-rated storage charges of \$150/month for library furniture from 12/1/2012 - 1/8/2013. Manufacturer: Haworth | 189.00 | \$ 189.00 |
| NOTES: | | | | | |
| All of the above storage/delivery charges are based on the library building completion date of 1/9/2013 at which time Yamada will begin installation of the library furniture. | | | | | |
| TOTAL CHARGES | | | | | \$ 1,166.00 |

1. This quotation is subject to change unless accepted within 30 days from the above date.
2. Shipping dates are approximate and are based upon receipt of all necessary information.
3. Prices quoted do not include direct taxes imposed by Federal, State or Municipal authorities unless stated.
4. A service charge of 1½% per month (18% annum) will be charged on all past due accounts.

Noah Read
 noah@yamadaenterprises.com



DOUG WALL CONSTRUCTION, INC.
CA SL LK # 143112

PROPOSED CHANGE ITEM

| | |
|-------------|---|
| PENDING | X |
| Approved | |
| OWNER | X |
| SUBCONTRACT | |
| Internal | |

PROJECT: Cabazon Civic Center

Proposed Change Number 168

RFP #

DATE: 1/2/2013

TO: Dominick Lombardi
Tom Howell

COST CODE:

JOB # 1032

The Original Construction Agreement is hereby modified and amended by the following deviations from original plans and specifications:

| | |
|--|------------|
| Solid Surface Counter Top at Stem Walls | \$3,000.00 |
| Extend Laminate on 4" Toe-Kicks due to 3" Base (See Picture) | \$340.00 |
| Round Off 90 Degree Corners to Be Rounded | \$680.00 |

| | |
|----------------------------|------------|
| Subtotal | \$4,020.00 |
| Profit and Overhead 5% | \$201.00 |
| Subtotal | \$4,221.00 |
| Bonding and Insurance 1.5% | \$63.00 |
| Total | \$4,284.00 |

| | |
|--------------------------------|------------|
| Original Contract Amount | |
| Total Previous Change Orders | |
| Total Before this Change Order | |
| Amount of this Change Order | Pending |
| Revised Contract Amount: | \$4,284.00 |

Riverside County EDA
 SIGNED: _____
 DATED: _____
 TITLE: _____

DOUG WALL CONSTRUCTION INC.
 SIGNED: _____
 DATED: _____
 TITLE: _____

Architect:
 SIGNED: _____
 DATED: _____
 TITLE: _____

David M. Bertino, Mfg. Inc.

Contractor License #520857 - Woodwork Institute #406

DATE: January 2, 2013

1696 W. Mill St., units 21-22
Colton, CA. 92324
Phone (909) 888-9122 Fax (909) 381-5577

Attn: Mike Glenn
Doug Wall Construction, Inc.
78450 Avenue 41
Bermuda Dunes, CA 92203
(PH) (760) 772-8446 (Fax) (760) 772-9407

Prepared by: John Parkes

Proposed Change Order for Building A

| |
|--|
| <p>JOB NAME: Cabazon Civic Center</p> <p>Our Job #6058</p> <p>Proposed Change Order to ADD 30ft of solid surface stem wall cap, 37ft of laminate at toe kicks because of top set base being only 3" high and rounding 7 corners at countertops.</p> <p>30 ft of solid surface stem wall cap at \$100.00 ft = \$3,000.00 37 ft of laminate at toe kicks because of top set base being only 3" high. 4 hrs at \$85.00 = \$340.00 Rounding 7 corners at specified countertops. 8 hrs at \$85.00 = \$680.00</p> <p>TOTAL for this Proposed Change Order is an ADD of \$4,020.00</p> <p>We will not proceed until we receive a signed Change Order from you.</p> |
|--|



DOUG WALL CONSTRUCTION, INC.
CA 90630 748112

| | |
|-------------|---|
| PENDING | X |
| Approved | |
| OWNER | X |
| SUBCONTRACT | |
| Internal | |

PROPOSED CHANGE ITEM

PROJECT: Cabazon Civic Center

Proposed Change Number 169

RFP #

DATE: 1/9/2013

TO: Dominick Lombardi
Tom Howell

COST CODE:

JOB # 1032

The Original Construction Agreement is hereby modified and amended by the following deviations from original plans and specifications:

| | |
|-------------------------------|------------|
| Add Hail Guards | \$7,929.00 |
| Added Painting of Hail Guards | \$658.00 |

| | |
|----------------------------|------------|
| Subtotal | \$8,587.00 |
| Profit and Overhead 5% | \$429.00 |
| Subtotal | \$9,016.00 |
| Bonding and Insurance 1.5% | \$135.00 |
| Total | \$9,151.00 |

| | |
|--------------------------------|---------------|
| Original Contract Amount | _____ |
| Total Previous Change Orders | _____ |
| Total Before this Change Order | _____ |
| Amount of this Change Order | Pending _____ |
| Revised Contract Amount: | _____ |

Riverside County EDA
 SIGNED: _____
 DATED: _____
 TITLE: _____

DOUG WALL CONSTRUCTION INC.
 SIGNED: _____
 DATED: _____
 TITLE: _____

Architect:
 SIGNED: _____
 DATED: _____
 TITLE: _____

Bid Spread Sheet

Job Name Cabazon Civic Center
 Hail Guards
 Bid # 211010

| | Amount | Rate / Per | Quote / Bid |
|---------------------------|--------|------------|-------------|
| Equipment | | | |
| Package Units | | | 0.00 |
| Curbs | | | 0.00 |
| Exhaust Fans | | | 0.00 |
| Evaporative Cooler | | | 0.00 |
| Hail Guards | 1 | 4560 | 4,560.00 |
| | | | 0.00 |
| | | | 0.00 |
| | | | 0.00 |
| Controls | | | |
| Thermostats | | | 0.00 |
| Wire | | | 0.00 |
| Conduit | | | 0.00 |
| Evaporative Cooler Switch | | | 0.00 |
| VAV Boxes | | | 0.00 |
| CO2 Sensor | | | 0.00 |
| | | | 0.00 |
| Duct | | | |
| Round | | | 0.00 |
| Lined Round | | | 0.00 |
| 18 ga Lined Round | | | 0.00 |
| Lined Rectangle | | | 0.00 |
| Bare Rectangle | | | 0.00 |
| Evaporative Rect. | | | 0.00 |
| | | | 0.00 |
| Air Distribution | | | |
| Registers | | | 0.00 |
| Louvers | | | 0.00 |
| Evap. Cooler Grille | | | 0.00 |
| Linear Diffusers | | | 0.00 |
| Linear Plenums | | | 0.00 |
| Young Regulator | | | 0.00 |
| Airelink RBDR | | | 0.00 |
| Accessories | | | |
| Filter Bank | | | 0.00 |
| Copper Linsets | | | 0.00 |
| Vibration Isolation | | | 0.00 |
| Hardware | | | 0.00 |
| Fire Dampers | | | 0.00 |
| Access Doors | | | 0.00 |
| Evap. Cooler Supports | | | 0.00 |
| Roof Flashings | | | 0.00 |
| Unit Flashing 20' | | | 0.00 |
| Rental | | | |
| Crane | | | 0.00 |
| Man Lifts | | | 0.00 |
| Fork lifts | | | 0.00 |

| | | | | |
|--------------------|--------------------------|-----------|----------|-----------------|
| Misc | | | | |
| | General Metal | | 0.00 | |
| | Filters | | 0.00 | |
| | | | | |
| Total Material | | | 4,560.00 | |
| Tax | 8.00% | | 364.80 | |
| Subtotal | | | 4,924.80 | |
| Subs w/ markup | | | 0.00 | |
| Air Metrx | | | 0.00 | |
| | | | 0.00 | |
| | | | 0.00 | |
| | | | 0.00 | |
| | | | 0.00 | |
| Total | | | 0.00 | |
| | | | | |
| Labor | | | | |
| | Supervision / Layout | 2 | 85 | 170.00 |
| | Equipment Unit Set | | | 0.00 |
| | ISO Curb Install | | | 0.00 |
| | Hail Guard Install | 24 | 75 | 1,800.00 |
| | Exhaust Fan Curb Install | | | 0.00 |
| | Evap cooler Install | | | 0.00 |
| | Econo / Power exhaust | | | 0.00 |
| | Round Duct install | | | 0.00 |
| | Rectangle Duct install | | | 0.00 |
| | Register Install | | | 0.00 |
| | Fire Damper Install | | | 0.00 |
| | Smoke Detector Install | | | 0.00 |
| | Flashing Install | | | 0.00 |
| | Line set install | | | 0.00 |
| | Start Up | | | 0.00 |
| | Commissioning | | | 0.00 |
| | Controls Install | | | 0.00 |
| | TOTALS | 26 | | 1,970.00 |
| | | | | |
| Subtotal | | | | 6,894.80 |
| Overhead | 10.00% | | | 689.48 |
| Profit | 5.00% | | | 344.74 |
| | | | | |
| Grand Total | | | | 7,929.02 |



Proposal

Prepared For: FMS

Date: January 7, 2013

Proposal Number: W2-125925-1

Job Name: Cabazon Civic Center

Delivery Terms:

Freight Allowed and Prepaid - F.O.B. Factory

Payment Terms:

Net 30 Days

Tag Data - 3-10 Ton R410A PKGD Unitary Gas/Electric Rooftop

| Item | Tag(s) | Qty | Description | Model Number |
|------|---------------------|-----|---|---------------------------|
| A1 | AC-A1 | 1 | 17 1/2 Ton Packaged Unitary Gas/Elec | YCD211E3L |
| A2 | AC-B2 | 1 | 15 Ton Packaged Unitary Gas/Elec | YCD181E3L |
| B1 | AC-A2 | 1 | 3 Ton R410A PKGD Unitary Gas/Electric | YSC036E3RMA--D00000000000 |
| B2 | AC-A3 | 1 | 4 Ton R410A PKGD Unitary Gas/Electric | YSC048E3RMA--D00000000000 |
| B3 | AC-A4, AC-A5, AC-A7 | 3 | 7.5 Ton R410A PKGD Unitary Gas/Electric | YSC092E3RMA--000000000000 |
| B4 | AC-A6 | 1 | 8.5 Ton R410A PKGD Unitary Gas/Electric | YSC102E3RMA--000000000000 |
| B5 | AC-B1 | 1 | 7.5 Ton R410A PKGD Unitary Gas/Electric | YSC092E3RMA--000000000000 |
| B6 | AC-B3 | 1 | 4 Ton R410A PKGD Unitary Gas/Electric | YSC048E3RMA--D00000000000 |
| B7 | AC-C1 | 1 | 7.5 Ton R410A PKGD Unitary Gas/Electric | YSC092E3RMA--000000000000 |
| B8 | AC-C2 | 1 | 5 Ton R410A PKGD Unitary Gas/Electric | YSC060E3RMA--000000000000 |

Coil Guards for above units:

- Heavy Guage Galvanized Steel Construction
- Color matched to Existing units
- 3/4" x 1 3/4" Expanded Metal

General Information:

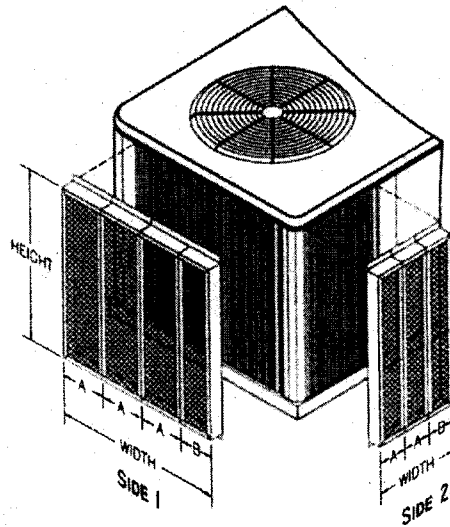
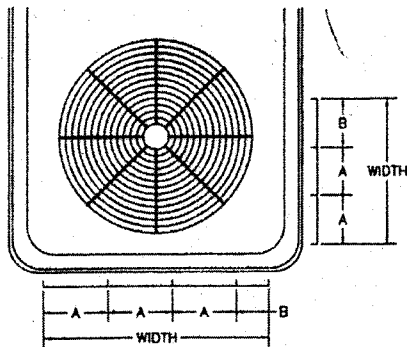

Total Net Price (Excluding Sales Tax).....\$ 4560

Trane U.S. Inc.
 17760 Rowland Street
 Rowland Heights, CA 91748-1119
 Phone: (626) 913-7123

This proposal is subject to your acceptance of the attached Trane terms and conditions.



Moreno and Sons Painting, Inc.

75735 Ramon Road
Thousand Palms, Ca 92276
760-343-3141
Fax-760-343-2062

| | |
|-----------|------------|
| Date | Estimate # |
| 1/10/2013 | 12-779 |

CA Lic #354911 Classification B,C9,C33

Name / Address

Doug Wall Construction Inc.
78-450 Avenue 41
Bermuda Dunes, CA 92203

| |
|-----------------|
| Project |
| Cabazon Civi... |

| Description | Cost | Total |
|--|--------|------------------------------|
| <p>We are pleased to submit our proposal for painting of the above referenced project as descibed below: This proposal is based solely upon the particular drawings, specifications and other contract documents listed and further designations, clarifications stated and qualifications stated by Moreno And Sons Painting, Inc.</p> <p style="text-align: center;">Scope of Work includes:</p> | | |
| Enamel New Hail Guards on Air Condition Units | 658.00 | 658.00 |
| <p>All invoices are due upon completion of the work.</p> <p>Thank you for the opportunity, we look forward to serving you.</p> | | <p>Total \$658.00</p> |

**SUCCESSOR AGENCY TO THE REDEVELOPMENT AGENCY
FOR THE COUNTY OF RIVERSIDE
CHANGE ORDER NO. 15**

Date: 2/28/2013

Project: Cabazon Civic Center

To Contractor:
Doug Wall Construction, Inc.
78450 Avenue 41
Bermuda Dunes, CA 92203

Project No: ED1308000412
Distribution:
Project Manager Construction Manager
Contractor Inspector
Fiscal Architect/Engineer

You are directed to make the following changes. Changes shall include labor, material and equipment; each item to include all charges or indirect arising out of this work:

| | | | |
|--|--------|----|-----------|
| 1) Metal posts at D and metal plates for trellis COR #170 | ADD | \$ | 1,620.00 |
| 2) Conduit for security at Bldg C COR #171 | ADD | \$ | 482.00 |
| 3) Added path of travel signs COR #173 | ADD | \$ | 2,878.00 |
| 4) Sod at Library COR #174 | ADD | \$ | 1,429.00 |
| 5) Doug Wall General Conditions COR #175 | ADD | \$ | 49,328.00 |
| 6) Regrade Plaza area - RFI 321 COR # 176 | ADD | \$ | 998.00 |
| 7) Relocate bus stop sign COR # 177 | ADD | \$ | 421.00 |
| 8) Nature Tech credit COR #178 | Deduct | \$ | 19,327.00 |
| 9) Credit for tack boards COR #179 | Deduct | \$ | 2,639.00 |
| 10) Library indoor signage COR #180 | ADD | \$ | 6,789.00 |
| 11) Window film COR #181 | ADD | \$ | 1,050.00 |
| 12) Library lockers COR #182 | ADD | \$ | 1,849.00 |
| 13) Library storage shelving COR #183 | ADD | \$ | 939.00 |
| 14) FSA kitchen shelving per RCEH COR #184 | ADD | \$ | 2,930.00 |

The specifications, where pertinent, shall apply to these changes.

This Change Order provides for a time extension of 0 calendar days

| | |
|--|------------------|
| Original Contract Duration (calendar days): | <u>450</u> |
| Prior Authorized Time Extension (calendar days): | <u>110</u> |
| Revised Construction Duration (calendar days): | <u>560</u> |
| Original Contract Completion Date: | <u>10/5/2012</u> |
| Revised Contract Completion Date: | <u>1/25/2013</u> |

NOTE: This change order is not effective until ALL signatures below are obtained, and if applicable, signature authority approval by Form 11 as indicated per Change Order Guidelines.

The undersigned contractor has given careful consideration to the change proposed, including its effect on other work already contracted for, and hereby agrees, if this change order is approved, that he will provide all equipment, furnish all materials, except as may otherwise be noted above, and perform all services necessary for the work above specified, and will accept as full payment for all costs related in any way thereto the prices shown above.

1) [Signature] 3-20-13
Contractor (signature) Date

| | | |
|-------------------------------------|----|----------------------|
| Original Contract | \$ | <u>11,990,000.00</u> |
| Prior Authorized [] ADD [] DED | \$ | <u>1,029,191.10</u> |
| Total Contract Prior to this Change | \$ | <u>13,019,191.10</u> |

Mike Glend
Contractor's Printed name

2) [Signature]
John J. Benoit, Chairman
Board of Supervisors (signature) Date

| | |
|----------------------------------|---------------------|
| Authorized Changes on this C.O.: | |
| Addition | \$ <u>70,713.00</u> |
| Deduction | \$ <u>21,966.00</u> |

John J. Benoit
Chairman, Board of Supervisors
Printed name

NET: [x] Addition [] Deduction \$ 48,747.00

3) [Signature] 3/20/13
Architect (signature) Date

Amount of Contract Authorized
Including this Change Order \$ 13,067,938.10

Thomas Howell
Architect's Printed name

Pursuant to:
[] Board Resolution 2012-034
[] M.O. and Date _____

ATTEST:

KECIA HARRER-HEM, Clerk
By [Signature]
DEPUTY

4) [Signature] 3/20/13
Project Manager (signature) Date

Dominick Lombardi
Project Manager's Printed name

Successor Agency Change Order Form - Revised 07-26-12

FORM APPROVED COUNTY COUNCIL

JUN 18 2013 4-2

BY: [Signature] 5/23/13
DATE



DOUG WALL CONSTRUCTION, INC.
CA St. Lic # 7-8112

PROPOSED CHANGE ITEM

| | |
|-------------|---|
| PENDING | X |
| Approved | |
| OWNER | X |
| SUBCONTRACT | |
| Internal | |

PROJECT: Cabazon Civic Center

Proposed Change Number 180

RFP #

DATE: 1/31/2013

TO: Dominick Lombardi
Tom Howell

COST CODE:

JOB # 1032

The Original Construction Agreement is hereby modified and amended by the following deviations from original plans and specifications:

Add for Murals at Library \$6,370.00

| | |
|----------------------------|------------|
| Subtotal | \$6,370.00 |
| Profit and Overhead 5% | \$319.00 |
| Subtotal | \$6,689.00 |
| Bonding and Insurance 1.5% | \$100.00 |
| Total | \$6,789.00 |

Original Contract Amount _____
 Total Previous Change Orders _____
 Total Before this Change Order _____
 Amount of this Change Order _____
 Revised Contract Amount: _____

Pending \$6,789.00

Riverside County EDA
 SIGNED: _____
 DATED: _____
 TITLE: _____

DOUG WALL CONSTRUCTION INC.
 SIGNED: _____
 DATED: _____
 TITLE: _____

Architect:
 SIGNED: _____
 DATED: _____
 TITLE: _____



SIGN SOLUTIONS

WWW.SO.CALSIGN.SOLUTIONS.COM LICENSE #: 968932
5637 ARROW HWY., SUITE H • MONTCLAIR, CA • 91763
"SIGNS WITHOUT LIMITS"

- ARCHITECTURAL SIGNS
- DESIGNERS
- MANUFACTURERS
- CONSULTANTS

P: 909-628-7660
F: 909-628-7664

Estimate

| Date | Estimate # |
|-----------|------------|
| 1/30/2013 | 827 |

| Name / Address |
|---|
| Doug Wall Construction, Inc. 78450 Ave 41 Bermuda Dunes, CA 92203 |

| Ship To |
|----------------------|
| Cabazon Civic Center |

| P.O. No. | Terms | Rep | Project |
|----------|----------|------|---------|
| | Contract | Haji | |

| Item | Description | Qty | Cost | Total |
|---------|--|-----|----------|----------|
| Signage | Fabricate and Paint Custom 1/2" Thick Sintra to read " Information" | 1 | 770.00 | 770.00 |
| Signage | Fabricate and Paint Custom 1/2" Thick Sintra to read " The Edge" | 1 | 425.00 | 425.00 |
| Signage | Fabricate and Paint Custom 1/2" Thick Sintra with Brushed aluminum finish to read " Children's Corner" | 1 | 975.00 | 975.00 |
| Signage | Fabricate, design and application of Muriel Graphics Frosted Vinyl application (35" X 237" | 1 | 3,350.00 | 3,350.00 |
| Install | Installation Charges for letters | | 650.00 | 650.00 |

| | | |
|---|--------------|------------|
| Thank you for the opportunity to provide you with the estimate you requested. | Total | \$6,170.00 |
|---|--------------|------------|

Customer Signature _____



DOUG WALL CONSTRUCTION, INC.
CASLER # 74912

| | |
|-------------|---|
| PENDING | X |
| Approved | |
| OWNER | X |
| SUBCONTRACT | |
| Internal | |

PROPOSED CHANGE ITEM

PROJECT: Cabazon Civic Center

Proposed Change Number 181

RFP #

DATE: 1/31/2013

TO: Dominick Lombardi
Tom Howell

COST CODE:

JOB # 1032

The Original Construction Agreement is hereby modified and amended by the following deviations from original plans and specifications:

Add Reflective Film (Gray or One-Way) to windows in A212 \$985.00

| | |
|----------------------------|------------|
| Subtotal | \$985.00 |
| Profit and Overhead 5% | \$49.00 |
| Subtotal | \$1,034.00 |
| Bonding and Insurance 1.5% | \$16.00 |
| Total | \$1,050.00 |

| | |
|--------------------------------|--------------------|
| Original Contract Amount | _____ |
| Total Previous Change Orders | _____ |
| Total Before this Change Order | _____ |
| Amount of this Change Order | Pending \$1,050.00 |
| Revised Contract Amount: | _____ |

Riverside County EDA
SIGNED: _____
DATED: _____
TITLE: _____

DOUG WALL CONSTRUCTION INC.
SIGNED: _____
DATED: _____
TITLE: _____

Architect:
SIGNED: _____
DATED: _____
TITLE: _____



MAGIK ENTERPRISES, INC.
 DBA Magik Glass and Door
 3500 E. Tachevah Drive, Ste A
 Palm Springs CA 92262
 760-325-1876

QUOTE

Quote Order#: 27795
 Service Record#: 34405
 Client#: 6275
 Date: 01/30/2013

License: (C-17) 686337
 Federal ID: 33-0206208

Billed To: DOUG WALL CONSTRUCTION, INC
 78-450 AVENUE 41
 BERMUDA DUNES CA 92230

Project: CABAZON CIVIC CENTER
 CABAZON CA

(760) 777-0075

| | | |
|-----------------------|--------------------|---------------|
| Scheduled: 01/30/2013 | Sales Person: 1220 | PO#: |
| Time: | Employee: | Map: |
| Department: 300 | | Cross Street: |
| TIME IN: _____ | | |
| TIME OUT: _____ | | |
| COMPLETED BY: _____ | | |
| DATE: _____ | | |

Quantity Description

Notes

SCOPE OF WORK: APPLY FILM TINT ONTO EXISTING DUAL PANE GLASS TEMPERED GLASS PANELS.
 #SLYRDS10 GRAY OR #RN07GSRPS ONE WAY FILM
 1- approx 22" x 96"
 1- approx 50" x 96"
 1- approx 46" x 96"
 1- approx 42" x 28"
 1- approx 42" x 22"
 2- approx 30" x 22"
 1- approx 10" x 45"
 TOTAL PRICE \$ 985.00
 PLEASE NOTE: EXISTING TEMPERED GLASS CAN BE PITTED AND WILL CAUSE FILM TO HAVE SMALL AIR BUBBLES.
 ONE WAY FILM WILL HAVE REVERSE EFFECT AT NIGHT, NEEDS 12 TO 1 LIGHTING TO WORK. PRICE IS BASED ON
 NON-PREVAILING WAGE.

Contractors are required by law to be licensed and regulated by the Contractor's State License Board. Any questions concerning the responsibilities of a contractor may be referred to the Registrar of the Board whose address is: Contractor's State License Board P.O. Box 2600 Sacramento, California 95826 1-800-321-CSLB or 2752

| | |
|-------------------|-------------|
| Deposit: | 0.00 |
| Sales Tax: | 0.00 |
| Amount Due | 0.00 |

TERMS: Net 10 days, service charge of 1.5% per month (18% per annum) will be charged



DOUG WALL CONSTRUCTION, INC.
CASILLA # 743112

| | |
|-------------|---|
| PENDING | X |
| Approved | |
| OWNER | X |
| SUBCONTRACT | |
| Internal | |

PROPOSED CHANGE ITEM

PROJECT: Cabazon Civic Center

Proposed Change Number 182

RFP #

DATE: 1/31/2013

TO: Dominick Lombardi
Tom Howell

COST CODE:

JOB # 1032

The Original Construction Agreement is hereby modified and amended by the following deviations from original plans and specifications:

Add Lockers at Library \$1,735.00

| | |
|----------------------------|------------|
| Subtotal | \$1,735.00 |
| Profit and Overhead 5% | \$87.00 |
| Subtotal | \$1,822.00 |
| Bonding and Insurance 1.5% | \$27.00 |
| Total | \$1,849.00 |

| | |
|--------------------------------|------------|
| Original Contract Amount | _____ |
| Total Previous Change Orders | _____ |
| Total Before this Change Order | _____ |
| Amount of this Change Order | Pending |
| Revised Contract Amount: | \$1,849.00 |

Riverside County EDA
SIGNED: _____
DATED: _____
TITLE: _____

DOUG WALL CONSTRUCTION INC.
SIGNED: _____
DATED: _____
TITLE: _____

Architect:
SIGNED: _____
DATED: _____
TITLE: _____



16552 Burke Lane, Huntington Beach, CA 92647-4538
 (714) 843-9882 • (800) 444-4594 • FAX (714) 843-9202

QUOTATION

13021-M

To: Doug Wall Construction
 78450 Ave. 41
 Bermuda Dunes, Ca. 92203
Re: Lockers- Cabazon PL
Attn: Mike Glenn
FAX:

Date: 1-30-13
Job Location: Cabazon, Ca.
Est. Lead Time: 30-45 Days A.R.O.
Freight: Included
F.O.B.: Destination
Terms: Net 30

| ITEM | QTY. | PART NO. | DESCRIPTION | UNIT PRICE | EXTENSION |
|-------------------------|------|----------|--|------------|-------------------|
| | | | Manufacturer: Tennsco Product: Steel Lockers | | |
| 1 | 1 | | Triple assembly 3 wide 15x18x24 | | |
| 2 | 3 | | 15"W front base plate | | |
| 3 | 2 | | 18" Locker end base | | |
| 4 | 2 | | ADA sticker | | |
| 5 | 2 | | Installed ADA compliant lock | | |
| | | | General Notes: -Color: Tennsco Sand -See attached drawings and related information. -Only the (2) ADA openings have locks. Locks are not included on the other (7) openings. -Other black painted steel recessed handles will accept padlocks however they are not included. | | |
| COST OF MATERIAL | | | | | \$922.00 |
| SALES TAX 8% | | | | | 73.76 |
| FREIGHT | | | | | 384.00 |
| INSTALLATION | | | | | 355.00 |
| TOTAL | | | | | \$1,734.76 |



16552 Burke Lane, Huntington Beach, CA 92647-4538
(714) 843-9882 • (800) 444-4594 • FAX (714) 843-9202

1. This quotation is subject to change unless accepted within 60 days from the above date.
2. Shipping dates are approximate and are based upon receipt of all necessary information.
3. Prices quoted do not include direct taxes imposed by Federal, State or Municipal authorities unless stated.
4. A service charge of 1½% per month (18% annum) will be charged on all past due accounts.

Michael Scheffler

mike@yamadaenterprises.com

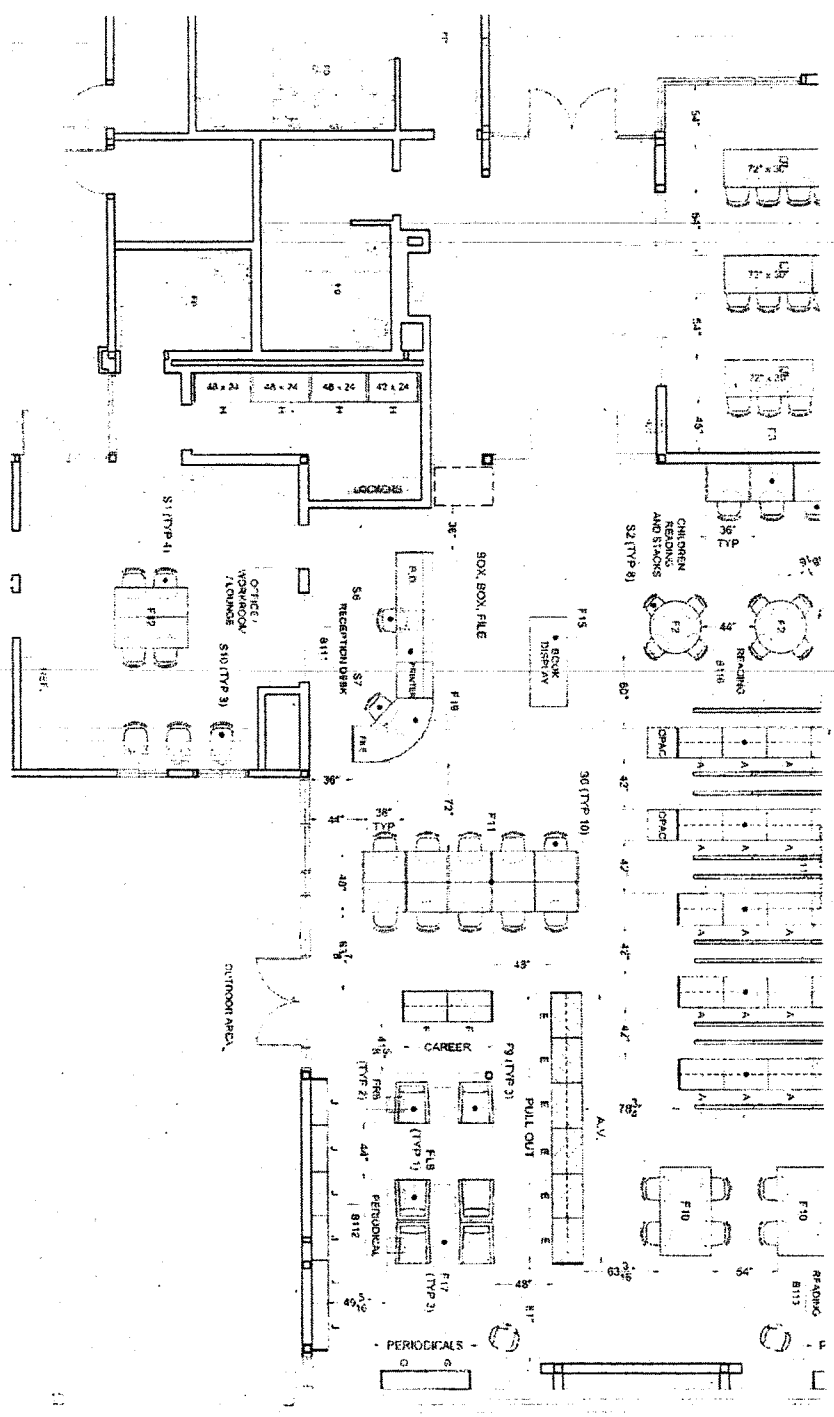

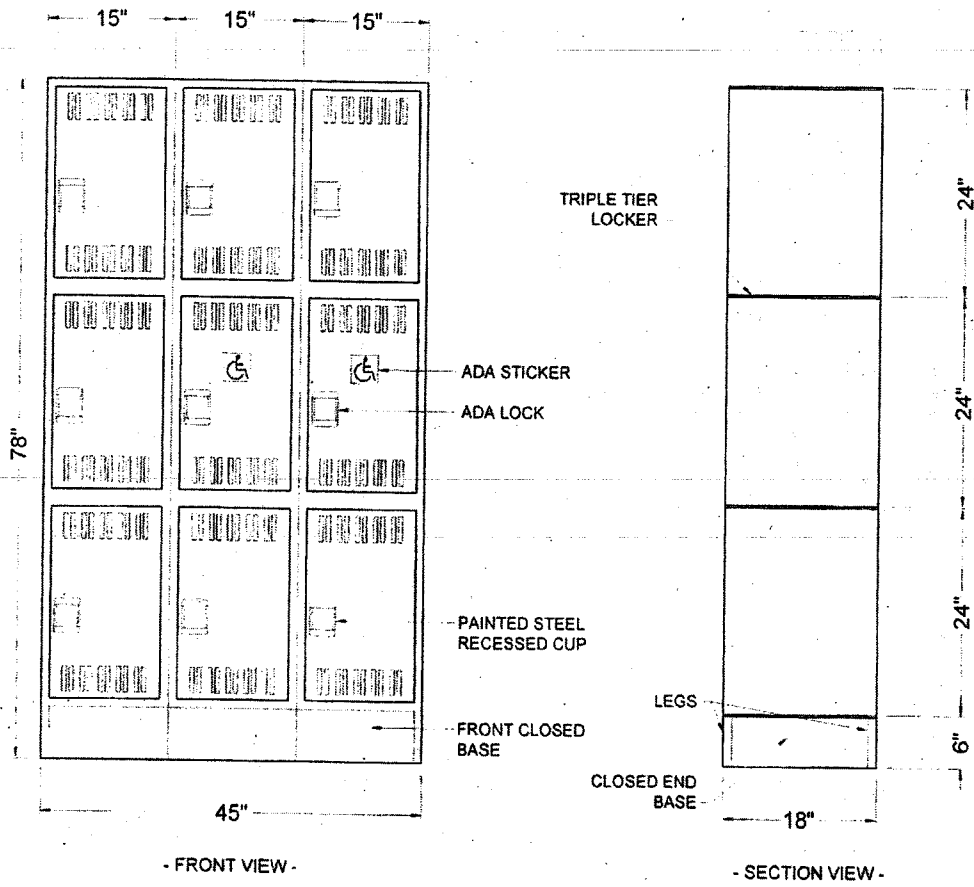

QTY: 1 (45"W)

| | | |
|---|---|---|
| <p>PROJECT</p> <p>CABAZON CIVIC CENTER</p> |  <p>YAMADA ENTERPRISES LIBRARY INTERIORS 16562 Burke Lane Huntington Beach, CA 92647 (562) 444-4304 FAX (714) 843-9202</p> | <p>NO. REVISION DATE</p> <p>- -</p> |
| <p>DESCRIPTION</p> <p>STEEL LOCKER TYPE: K</p> | | <p>DRAWN BY: O.TREJO</p> <p>DATE: 11-04-11</p> <p>SCALE 3/4" = 1'-0"</p> <p>SHEET K</p> |

Triple Tier Lockers

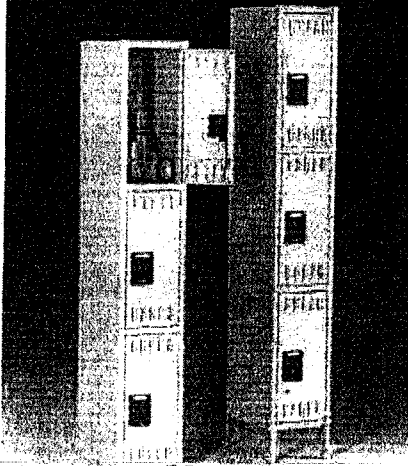

Triple tier lockers are ideal for health clubs, gymnasiums, and other applications where ample storage must be balanced with space savings. These units fit three times as many lockers in the space of a single tier locker and feature:

- Three coat hooks per opening
- Available in single or three-wide units
- Opening sizes of 9", 12", or 15" wide**
- Locker depths of 12", 15" or 18"***
- Positive 2 point locking system on doors
- Available with or without legs
- Louvers for ventilation
- Available fully assembled or unassembled
- Door stiffeners
- Optional locks and other accessories available, refer to pages 20-23.

**9" is available in assembled units only.*

*** Refer to price list for specific combinations.*

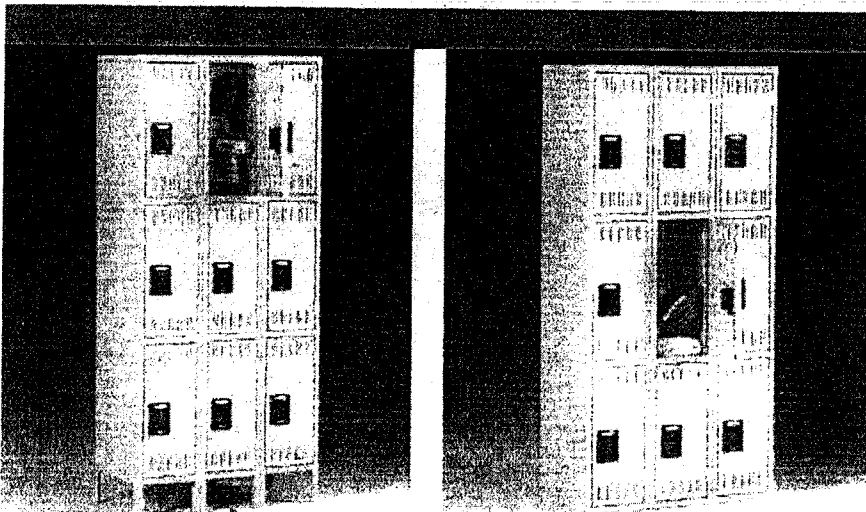

ITEM TTS.151824-3, 45"W x 18"D x 78"H overall.
Each locker is 15"W x 18"D x 24"H. Two lockers will
be ADA compliant.

Note: For safety, all lockers are required to be floor or wall anchored.

Locker Accessories

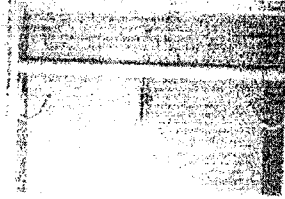

Coat Rod
These painted (sand color only) steel coat rods are $\frac{1}{2}$ " in diameter and are available in 9", 12", 15", 18", 21", and 24" lengths.

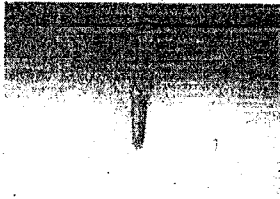

Coat Hook
Additional coat hooks can be added to any locker. Coat hooks can be factory welded into assembled units if specified at time of order. Single hook or double hook available.

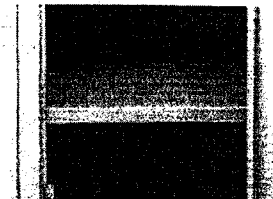

Shelves and Partitions
Add shelves to customize locker compartments or vertical partitions to create dual compartments in single tier lockers.

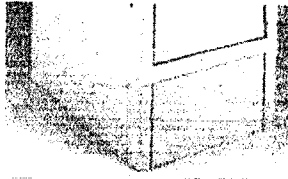

Front Base/Closed End Base
Closed front bases fit between front locker legs to provide a flush, finished appearance. End bases fit between front and rear legs of a row-ending locker.

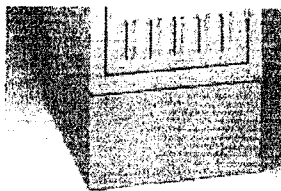

Closed Base
Used only on lockers with no legs, the closed base is a one piece, fully enclosed, 6" tall, steel base to raise the locker off the floor.

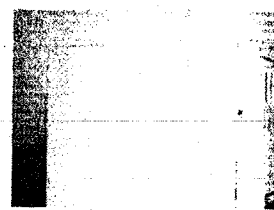

Locker End
Locker ends are used to finish a row and give a clean, attractive, appearance.

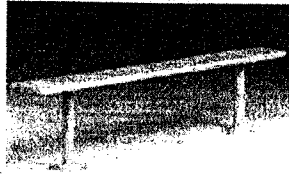

Locker Benches/Pedestals
A clear lacquer finish protects these $1\frac{1}{4}$ " thick laminated maple benches. Heavy duty steel pedestals have an enamel finish to match your lockers. Benches are $9\frac{1}{2}$ " wide and 36" to 144" long.

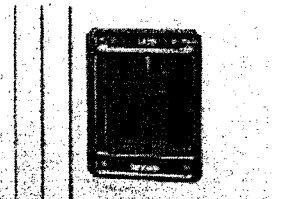

Painted Steel Recessed Cup
Vandals don't stand a chance - neither does rust! Our standard steel handles are painted with a black powder-coated finish and are scratch resistant.

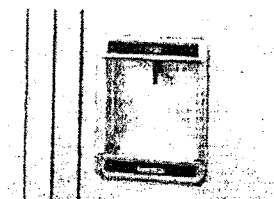

Stainless Steel Recessed Cup
Add an extra touch of quality with our optional stainless steel recessed cup. Scratch resistant.

Half-Height Lockers

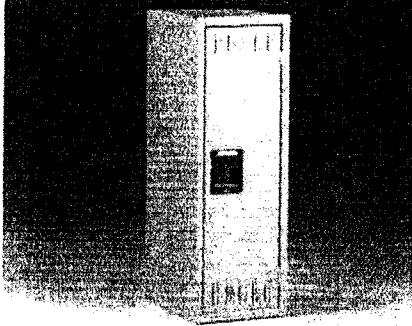

These versatile Half-Height Lockers offer all the storage options of full length lockers in half the space. Yet, there is plenty of available hanging space for shirts or jackets; perfect to slide under a workbench or desk!

- Single unit only, 12 wide" x 18" deep x 36" high
- Positive 3 point locking system on doors
- Louvers for ventilation
- Fully assembled only
- Door stiffeners
- Optional built-in locks
- Coat hooks
- Coat rod

ADA Compliant Lockers



It's important in the public sector to offer and identify accessibility for those that require enhanced access. Tensco ADA Compliant Lockers are specifically designed to provide easier access to contents from a seated position. This is achieved through your choice of a bottom riser to raise the lower shelf, an ADA compliant lock, or coat hooks and upper shelf at a reduced height.

The special ADA compliant lock allows the locker to be opened by simply inserting the key. No turning of the key is required allowing for single handed operation.

Best of all, Tensco will modify several of their standard lockers offering a variety of choices. ADA Compliant lockers are available for single tier, the bottom locker of a double tier, or the bottom two lockers of a triple tier.

These ADA Compliant lockers are shipped with the universal handicap symbol to notify those not to block access to these lockers.

Note: For safety, all lockers are required to be floor or wall anchored.

tensco

SYSTEMS FOR SUCCESS



DOUG WALL CONSTRUCTION, INC.
CASTLE # 73312

PROPOSED CHANGE ITEM

| | |
|-------------|---|
| PENDING | X |
| Approved | |
| OWNER | X |
| SUBCONTRACT | |
| Internal | |

PROJECT: Cabazon Civic Center

Proposed Change Number 183

RFP #

DATE: 2/3/2012

TO: Dominick Lombardi
Tom Howell

COST CODE:

JOB # 1032

The Original Construction Agreement is hereby modified and amended by the following deviations from original plans and specifications:

| | |
|--|----------|
| Shelving for Library Storage and Mop Closet | \$324.00 |
| 1 Day Labor to Assemble and Install (8 Hrs @ \$60.00/Hr) | \$480.00 |

| | |
|----------------------------|----------|
| Subtotal | \$804.00 |
| Profit and Overhead 15% | \$121.00 |
| Subtotal | \$925.00 |
| Bonding and Insurance 1.5% | \$14.00 |
| Total | \$939.00 |

| | |
|--------------------------------|----------|
| Original Contract Amount | |
| Total Previous Change Orders | |
| Total Before this Change Order | |
| Amount of this Change Order | Pending |
| Revised Contract Amount: | \$939.00 |

Riverside County EDA
 SIGNED: _____
 DATED: _____
 TITLE: _____

DOUG WALL CONSTRUCTION INC.
 SIGNED: _____
 DATED: _____
 TITLE: _____

Architect:
 SIGNED: _____
 DATED: _____
 TITLE: _____



LOWE'S HW, INC.
78-865 HIGHWAY 111
LA QUINTA, CA 92253 (760) 771-5566

- SALE -

SALES#: S0208VA1 1696837 TRANS#: 47910300 02-03-13

319468 PREMIER 5-TIER 24X48 BLAC 92.48
SUBTOTAL: 92.48
TAX: 7.40
INVOICE 27215 TOTAL: 99.88
M/C: 99.88

M/C:XXXXXXXXXXXX9886 AMOUNT:99.88 AUTHCD:46071S
KEYED REFID:910370020827 02/03/13 08:52:50

[Signature]

STORE: 0200 TERMINAL: 27 02/03/13 08:53:01

OF ITEMS PURCHASED: 1
EXCLUDES FEES, SERVICES AND SPECIAL ORDER ITEMS



THANK YOU FOR SHOPPING LOWE'S.
SEE REVERSE SIDE FOR RETURN POLICY.
STORE MANAGER: JESUS UCCLES

WE HAVE THE LOWEST PRICES, GUARANTEED!
IF YOU FIND A LOWER PRICE, WE WILL BEAT IT BY 10%.
SEE STORE FOR DETAILS.



Savings Made Simple

SAM'S CLUB
CLUB MANAGER DENISE FLOWERS
(760) 770-7146
Visit SamsClub.com
02/02/13 09:57 9889 6609 013

2051

W MEMBER 101-*****5978

THANK YOU
DOUG WALL CONSTRUCTION INC
78450 AVENUE 41
INDIO, CA 92203

| | |
|------------------------|----------|
| E 762585 TOMATO | 4.98 N |
| E 951721 SMKGOUDA CHEF | 9.98 N |
| 864596 STORAGE | 149.98 T |
| 864596 STORAGE | 149.98 T |

| | | |
|-------|------------|--------|
| TAX 1 | SUBTOTAL | 337.68 |
| | 8.000 % | 25.82 |
| | TOTAL | 363.50 |
| | MCARD TEND | 363.50 |

ACCOUNT # 9886
APPROVAL # 405935
TERMINAL # MX103449
02/02/13 09:57:59
CHANGE DUE 0.00

Visit samsclub.com to see your savings

ITEMS SOLD 6

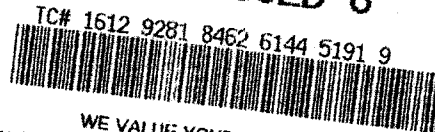

WE VALUE YOUR OPINION.
WE WANT TO KNOW ABOUT YOUR SHOPPING
EXPERIENCE TODAY AT SAM'S CLUB
Please complete a survey about today's club visit at:
<http://www.survey.samsclub.com>
IN RETURN FOR YOUR TIME YOU COULD RECEIVE
ONE OF FIVE \$1,000 SAM'S CLUB SHOPPING CARDS
You must be 18 or older and a legal resident of the
United States to enter. No purchase necessary to win.
To enter without purchase and for official rules visit:
www.entry.survey.samsclub.com
Sweepstakes period ends on the date shown in the
official rules. Survey must be taken within TWO weeks
of today.
Esta encuesta tambien se encuentra en español en la
página de Internet.

THANK YOU

Like us on Facebook at
facebook.com/samsclub
02/02/13 09:58:00

*** MEMBER COPY ***



DOUG WALL CONSTRUCTION, INC.
CA 92 LE #1012

| | |
|-------------|---|
| PENDING | X |
| Approved | |
| OWNER | X |
| SUBCONTRACT | |
| Internal | |

PROPOSED CHANGE ITEM

PROJECT: Cabazon Civic Center

Proposed Change Number 184

RFP #

DATE: 2/5/2013

TO: Dominick Lombardi
Tom Howell

COST CODE:

JOB # 1032

The Original Construction Agreement is hereby modified and amended by the following deviations from original plans and specifications:

Added Shelving/Delivery/Labor for Dry storage Shelves **\$2,930.00**

| | |
|----------------------------|-------------------|
| Subtotal | \$2,930.00 |
| Profit and Overhead 5% | |
| Subtotal | |
| Bonding and Insurance 1.5% | |
| Total | |

| | |
|--------------------------------|---------------------------|
| Original Contract Amount | _____ |
| Total Previous Change Orders | _____ |
| Total Before this Change Order | _____ |
| Amount of this Change Order | Pending \$2,930.00 |
| Revised Contract Amount: | _____ |

Riverside County EDA
SIGNED: _____
DATED: _____
TITLE: _____

DOUG WALL CONSTRUCTION INC.
SIGNED: _____
DATED: _____
TITLE: _____

Architect: _____
SIGNED: _____
DATED: _____
TITLE: _____

Perfection Stainless Fabrication, Inc.

901 SUMNER STREET—BAKERSFIELD, CA. 93305
PHONE (661) 324-5466 FAX (661) 324-7714 EMAIL: sales@perfectionsf.com

DATE: 2/4/13

Doug Wall Construction

REFERENCE QUOTE #2183

ATTENTION: Mike
RE: Cabazon Civic Center

In regard to your request for pricing information we are pleased to present the following quote for your consideration:

Cost to provide and install Metro Max Q Shelving to consist of 5 tiers, posts, and casters. Size to be 24 x 42.

Total Lump Sum \$2,930.00

NOTE: Your signature acknowledges this contract, authorizes this proposal, and work to proceed.

If you have any questions or need further information please call us at (661) 324-5466.

THANK YOU!

Sincerely,

Lyle Carmignani

AUTHORIZED BY:

(CUSTOMER SIGNATURE)

**** A CALIFORNIA CORPORATION** LICENSE #462114**



DOUG WALL CONSTRUCTION, INC.

CA SCL 00743112

| | |
|-------------|---|
| PENDING | X |
| Approved | |
| OWNER | X |
| SUBCONTRACT | |
| Internal | |

PROPOSED CHANGE ITEM

PROJECT: Cabazon Civic Center

Proposed Change Number 170

RFP #

DATE: 1/17/2013

TO: Dominick Lombardi
Tom Howell

COST CODE:

JOB # 1032

The Original Construction Agreement is hereby modified and amended by the following deviations from original plans and specifications:

| | |
|---|----------|
| Security Panels at Bldg D (Meeting Minutes item 5.03) See attached) | \$800.00 |
| Plates to Mount Exterior Lights at Shade Shelters | \$720.00 |

| | |
|----------------------------|------------|
| Subtotal | \$1,520.00 |
| Profit and Overhead 5% | \$76.00 |
| Subtotal | \$1,596.00 |
| Bonding and Insurance 1.5% | \$24.00 |
| Total | \$1,620.00 |

| | |
|--------------------------------|---------------|
| Original Contract Amount | _____ |
| Total Previous Change Orders | _____ |
| Total Before this Change Order | _____ |
| Amount of this Change Order | Pending _____ |
| Revised Contract Amount: | _____ |

Riverside County EDA
 SIGNED: _____
 DATED: _____
 TITLE: _____

DOUG WALL CONSTRUCTION INC.
 SIGNED: _____
 DATED: _____
 TITLE: _____

Architect:
 SIGNED: _____
 DATED: _____
 TITLE: _____



Change Order Proposal

TALLEY METAL FABRICATION

C00001
Change to: 805366

P.O. BOX 850
SAN JACINTO, CA. 92581-0850
PHONE (951) 654-2123 FAX (951) 654-3631 STATE LIC. 745822

| | | |
|---|----------------------------------|------------------|
| PROPOSAL SUBMITTED TO DOUG WALL CONSTRUCTION | PHONE (760) 777-0075 | DATE 01/16/13 |
| STREET | JOB NAME CABAZON CIVIC CENTER | |
| CITY, STATE, ZIP CA | JOB LOCATION CABAZON | EMAIL |
| ATTENTION MIKE GLENN | FAX (760) 772-9407 | JOB PHONE |

REVISED 1/16/13

ADDITIONAL WORK AUTHORIZATION FABRICATE AND INSTALL THE FOLLOWING:

| | | |
|---------------|---|------------------------|
| <i>Item 1</i> | (2) PANELS TO FILL GAP BETWEEN WALL AND FENCE | \$ 800.00 |
| <i>Item 2</i> | (12) 18"x18"x1/4" PL WELDED IN FIELD \$120.00 EACH | \$ 1,440.00 |
| | | \$ 720.00 |

SPECIFICATIONS:
PREVAILING WAGES INCLUDED
PRIME PAINT ONLY, FINISH PAINT BY OTHERS
PERMITS & FEES BY OTHERS

Customer agrees to pay contractors legal fees and other costs incurred to enforce payment. Unpaid balances bear service charge not to exceed legal limits permitted by law.

WE PROPOSE hereby to furnish material and labor-complete in accordance with above specifications, for the sum of:

DOLLARS \$ 0.00

PAYMENT TO BE MADE AS FOLLOWS:

All material is guaranteed to be as specified. All work to be completed in a workmanlike manner according to standard practices. Any alteration or deviation from above specifications involving extra costs will be executed only upon written orders, and will become an extra or delays beyond our control. Owner to carry fire, tornado and other necessary insurance. Our workers are fully covered by Workman's Compensation insurance.

AUTHORIZED SIGNATURE

JOE B. TALLEY JR., CEO

NOTE: This proposal may be withdrawn by us if not accepted within 30 days

ACCEPTANCE OF PROPOSAL: THE ABOVE PRICES, SPECIFICATIONS AND CONDITIONS ARE SATISFACTORY AND ARE HEREBY ACCEPT
YOU ARE AUTHORIZED TO DO THE WORK AS SPECIFIED. PAYMENT WILL BE MADE AS OUTLINED ABOVE.

DATE OF ACCEPTANCE: SIGNATURE

- 4.03 Decision was made to leave the sidewalk as is at the Water District and to not add steps to the outside drop off area.
- 4.04 Vinny to complete spreadsheet for amount of refrigerant in A/C units. MG to remind Vinnie.

5. OLD Business:

5.01 LEED:

MG to continue to coordinate with Brad Miller and Frank Segui. Commissioned domestic hot water and lighting controls on December 18.

5.02 MG sending final proposal from EDA for credit to Nature Tech

Item

5.03 Gaps at Building D CMU wall – Continue to next meeting. Idea is to attach a pole to the wall

5.04 Continued coordination for RFID system – January 22 is delivery day. Attachment to floor and electrical determined that day. AH and LSSI to have the computers installed before this date. SW to have books on site.

5.05 Library indoor signage needs to be finalized. Haji to send final submittal.

5.06 Mow curb at east end of skate park will be kept on agenda as a reminder until it is complete

5.07 TW confirmed he would like third party testing of the playground play surface. Leave on agenda as reminder for TW.

5.08 Looking for optional trellis light fixture.

5.09 AH to install PC's on January 14th. Grommet holes to be drilled on the 14th or at least marked for drilling.

6. SUBMITTALS:

DL

DL distributed submittal log for discussion.

6.01 Seed mix submittal: 02931-1 – officially approved at meeting by EDA(TW and DL)

6.02 Library indoor Signage (10431-10) – Children's area and plaques to be finalized.

6.03 Projection screens are still pending: 11132-1. Projectors to be delivered in one week by Total Plan Business Interiors.

7. RFI's:

DL

DL distributed the current RFI log.

7.01 – Grades at water district sidewalk – closed(see new business)

8. RFP's, COR's, Change Orders:

DL distributed the current Change Order Log

8.01 CO#10 Approved by the Board on 12/18/12

8.02 Nature Tech credit – MG sending final EDA proposal for credit

8.03 CO #11, 12, 13 in process to Board for Feb. 5 Board date

8.04 PCO 165 – confirm round standoffs for Dewey holders

Item 2

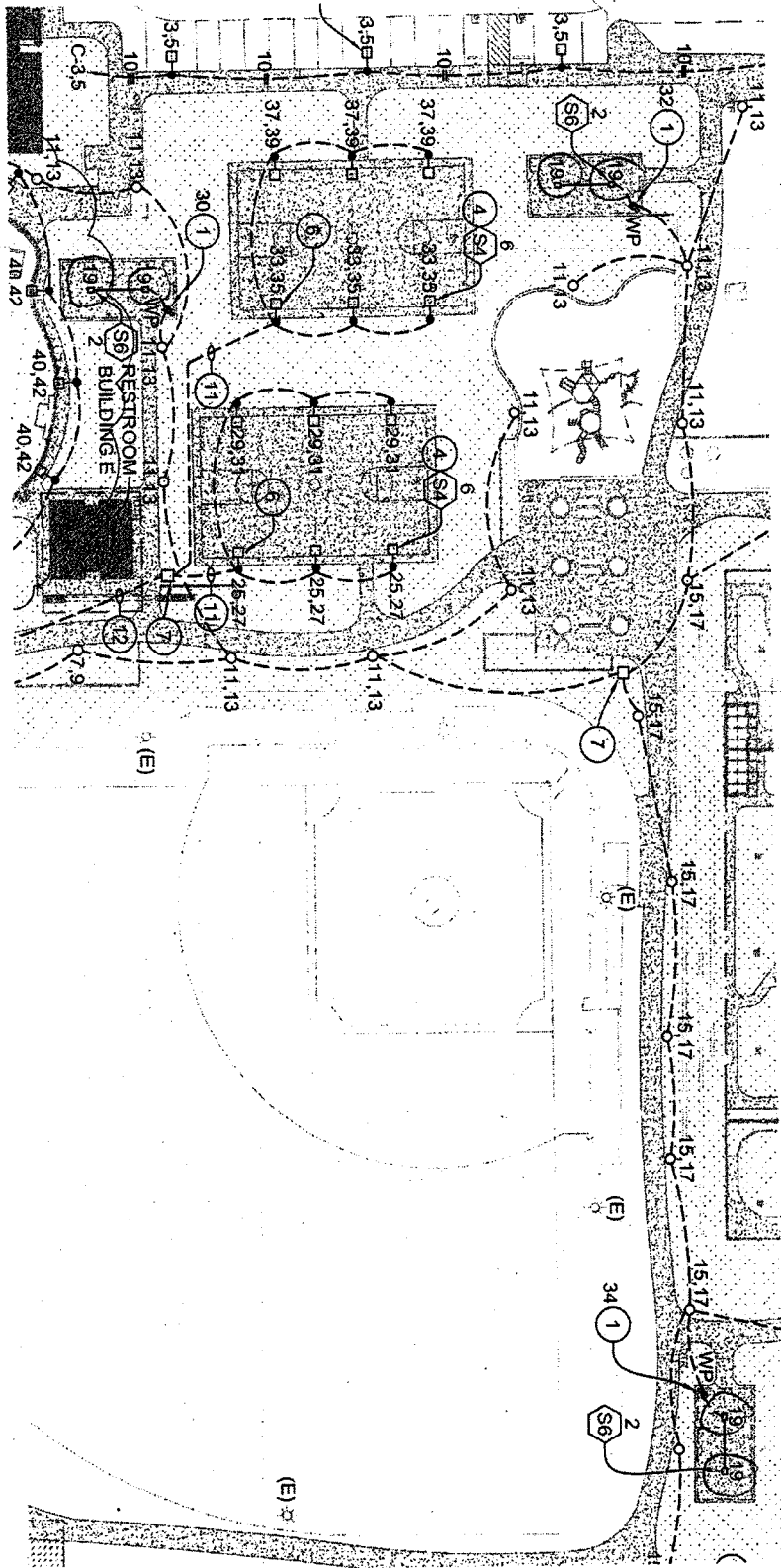



DOUG WALL CONSTRUCTION, INC.
CA #9. Lic # 746112

PROPOSED CHANGE ITEM

| | |
|-------------|---|
| PENDING | X |
| Approved | |
| OWNER | X |
| SUBCONTRACT | |
| Internal | |

PROJECT: Cabazon Civic Center

Proposed Change Number 171

RFP #

DATE: 1/17/2013

TO: Dominick Lombardi
Tom Howell

COST CODE:

JOB # 1032

The Original Construction Agreement is hereby modified and amended by the following deviations from original plans and specifications:

Added Conduit for Security Cameras on Bldg D \$453.00

| | |
|----------------------------|----------|
| Subtotal | \$453.00 |
| Profit and Overhead 5% | \$23.00 |
| Subtotal | \$475.00 |
| Bonding and Insurance 1.5% | \$7.00 |
| Total | \$482.00 |

| | |
|--------------------------------|------------------|
| Original Contract Amount | _____ |
| Total Previous Change Orders | _____ |
| Total Before this Change Order | _____ |
| Amount of this Change Order | Pending \$482.00 |
| Revised Contract Amount: | _____ |

Riverside County EDA
SIGNED: _____
DATED: _____
TITLE: _____

DOUG WALL CONSTRUCTION INC.
SIGNED: _____
DATED: _____
TITLE: _____

Architect:
SIGNED: _____
DATED: _____
TITLE: _____



LJC.# 870446
17205 Eucalyptus St. Suite C-10 Hesperia, CA 92345
Office (760)244-7700 Fax (760)244-5900

CONTRACT CHANGE ORDER REQUEST

TO: Mike Glenn, Doug Wall Construction

ADDRESS: 78450 Avenue 41

Bermuda Dunes, CA 92203-1001

DATE: 01/19/13

REQUEST NO.: 040

PROJECT: Cabazon Civic Center

PREPARED BY: Eddie Gleason

Install (30') of 1" Rigid Conduit and (2) weather proof boxes adjacent to BLDG D and stub through stucco to accessible ceiling space.

Labor Electrician:

- 4 hours installation PER BUILDING @ \$54.44 \$217.76

Material:

- Electrical Material \$160.69

O/H & P: (15% per General Conditions Article 19.1.11d1) \$56.77

Total: \$435.22

NOTE: The work covered by this order shall be performed under the same terms and conditions as that included in the original contract:

PTL ELECTRIC INC. AGREES hereby to make changes as specified above, at this price. \$435.22

ACCEPTED: The above prices and specifications of this change order are satisfactory and are hereby accepted. All work to be performed under same terms and conditions as specified in the original contract unless otherwise stipulated.

Signature: _____

Date: _____

CED - VICTORVILLE
 12137 INDUSTRIAL BLVD
 VICTORVILLE CA 92395
 TEL: 760 241-7443 FAX: 760 241-7447

CONTACT: ANDREW SINGLEDECKER

QUOTE FOR: PTL ELECTRIC

ACCT #: KB-63876 CABAZON CIVIC CENTER

CABAZON CIVIC CENTER
 17285 EUCALYPTUS STREET SUITE C18
 HESPERIA, CA 92345
 TEL: (760) 244-7700

| QUOTATION | | | Page |
|----------------|----------|-------------|------------|
| QUOTE # | Date | Rev # | 001 OF 001 |
| 1009123 | 01/16/13 | 000 | 01/16/13 |
| QUOTE EXPIRES | | PREPARED BY | |
| 02/15/2013 | | AS | |
| SLS | INSL | | |
| 013B | 3000 | | |
| FOB | FREIGHT | | |
| SHIPPING POINT | PREPAID | | |

| |
|----------------------|
| CLS PO #: |
| JOB NAME: |
| CABAZON CHANGE ORDER |

| LN | QTY | MFR | CATALOG # | DESCRIPTION | PRICE | UOM | EXT AMT |
|----|-----|-----|------------|-------------------------|--------|-----|---------|
| 01 | 30 | GAL | COND1 | GNLW STEEL | 267.03 | C | 80.11 |
| 02 | 3 | APP | NXC100 | 1-IN NO-THERD COND CONN | 836.20 | C | 25.09 |
| 03 | 4 | APP | CLB100MS | 1IN WALL CLAMP BACK | 196.00 | C | 7.84 |
| 04 | 4 | APP | CL100MS | 1IN 1H MALLEABLE CLMP | 130.65 | C | 5.23 |
| 05 | 2 | BWF | DB100221KV | 1IN SHL DP OLET BOX | 14.50 | E | 29.00 |
| 06 | 2 | BWF | BCLV | 1G WP GRY BLANK COVER | 0.75 | E | 1.52 |

MDSE: 148.79

TAX: 11.90

TOTAL: 160.69

PLEASE NOTE: THIS IS NOT AN OFFER TO CONTRACT, BUT MERELY A QUOTATION OF CURRENT PRICES FOR YOUR CONVENIENCE AND INFORMATION. ORDERS BASED ON THIS QUOTATION ARE SUBJECT TO YOUR ACCEPTANCE OF THE TERMS AND CONDITIONS STATED IN OUR WRITTEN ACKNOWLEDGEMENT OF ORDER. WE MAKE NO REPRESENTATION WITH RESPECT TO COMPLIANCE WITH JOB SPECIFICATIONS.



DOUG WALL CONSTRUCTION, INC.
CALIFORNIA LICENSE # 743112

PROPOSED CHANGE ITEM

| | |
|-------------|---|
| PENDING | X |
| Approved | |
| OWNER | X |
| SUBCONTRACT | |
| Internal | |

PROJECT: Cabazon Civic Center

Proposed Change Number 173

RFP #

DATE: 1/19/2013

TO: Dominick Lombardi
Tom Howell

COST CODE:

JOB # 1032

The Original Construction Agreement is hereby modified and amended by the following deviations from original plans and specifications:

Added Signage not specified on plans \$2,700.00

| | |
|----------------------------|------------|
| Subtotal | \$2,700.00 |
| Profit and Overhead 5% | \$135.00 |
| Subtotal | \$2,835.00 |
| Bonding and Insurance 1.5% | \$43.00 |
| Total | \$2,878.00 |

Original Contract Amount _____
 Total Previous Change Orders _____
 Total Before this Change Order _____
 Amount of this Change Order _____
 Revised Contract Amount: _____

Pending \$2,878.00

Riverside County EDA

SIGNED: _____
DATED: _____
TITLE: _____

DOUG WALL CONSTRUCTION INC.

SIGNED: _____
DATED: _____
TITLE: _____

Architect:

SIGNED: _____
DATED: _____
TITLE: _____



SIGN SOLUTIONS

WWW.SO CALSIGN SOLUTIONS.COM LICENSE #: 968932
 5637 ARROW HWY., SUITE H • MONTCLAIR, CA • 91763
 "SIGNS WITHOUT LIMITS"

- ARCHITECTURAL SIGNS
- DESIGNERS
- MANUFACTURERS
- CONSULTANTS

P: 909-628-7660
 F: 909-628-7664

Estimate

| | |
|-----------|------------|
| Date | Estimate # |
| 1/16/2013 | 824 |

| |
|---|
| Name / Address |
| Doug Wall Construction, Inc. 78450 Ave 41 Bermuda Dunes, CA 92203 |

| |
|----------------------|
| Ship To |
| Cabazon Civic Center |

| | | | |
|----------|----------|------|---------|
| P.O. No. | Terms | Rep | Project |
| | Contract | Haji | |

| Item | Description | Qty | Cost | Total |
|------------------|--|-----|---------------|-----------------------|
| Signage | Fabricate Fire Inspection Sign FACP 7"X 10" 0.080" aluminum | 10 | 60.00 | 600.00 |
| Signage | Fabricate Max Occupancy Sign Fire Inspection Sign 8" X 12" x 1/8 | 2 | 75.00 | 150.00 |
| Directional Sign | Fabricate 0.080" 12" X 18" Path of Travel Signs | 15 | 75.00 | 1,050.00 |
| Install | Installation Charges - required 12 Poles with Concrete footings | | 1,650.00 | 1,650.00 |
| | | | 825.00 | 825.00 |
| Total | | | | \$3,450.00 |

Customer Signature _____

~~2700.00~~
 \$2700.00

↓ = SINGLE
 ↓↓ = DOUBLE

* = PRIMARY (POLE MOUNTED OR BUILDING MOUNTED) SERVICE



Professional Engineer
 Registration No. 10000
 S.M. SHERMAN & ASSOCIATES, INC.
 10000
 10000

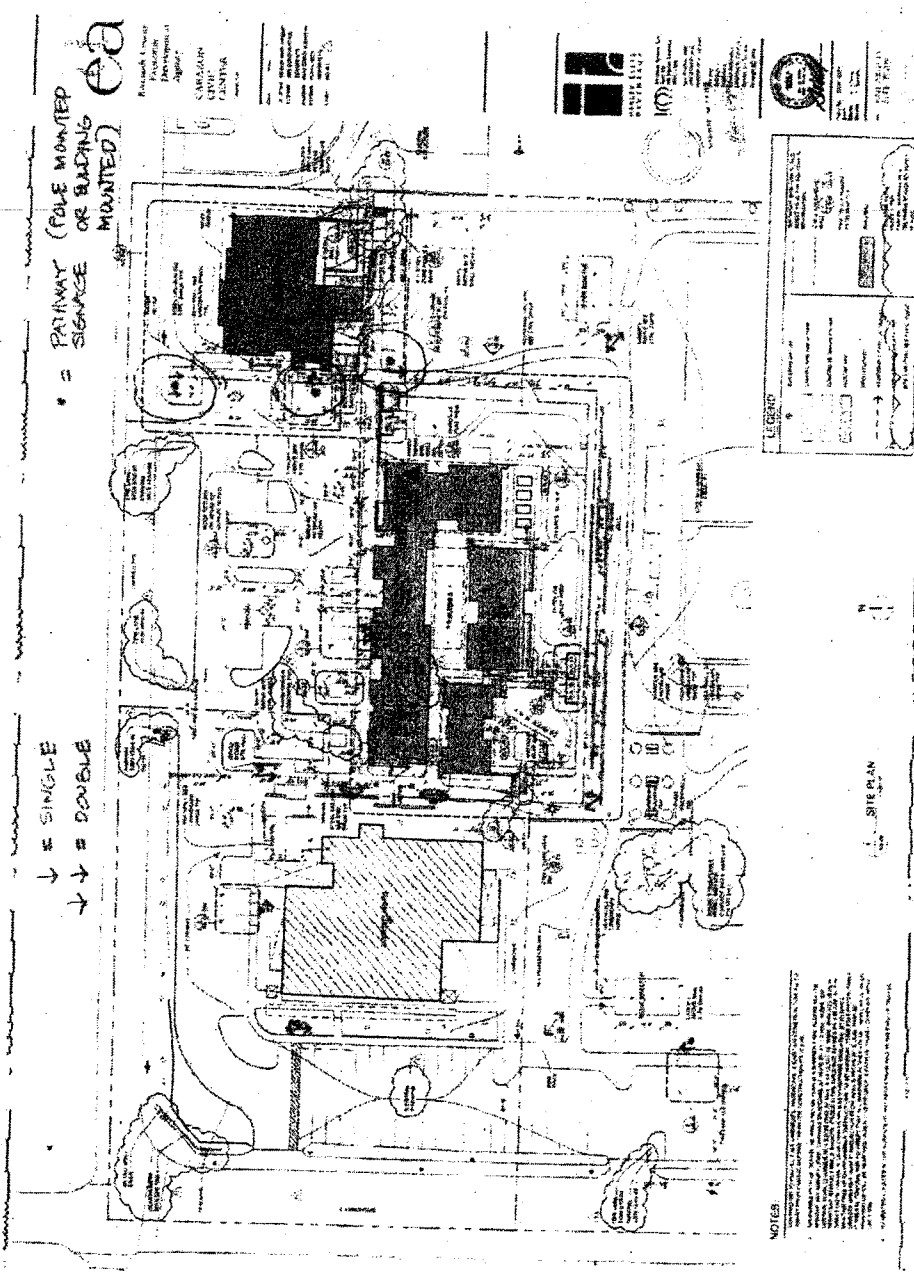

LEGEND

| | |
|----------|--------------------|
| [Symbol] | Proposed Building |
| [Symbol] | Existing Building |
| [Symbol] | Proposed Parking |
| [Symbol] | Existing Parking |
| [Symbol] | Proposed Driveway |
| [Symbol] | Existing Driveway |
| [Symbol] | Proposed Sidewalk |
| [Symbol] | Existing Sidewalk |
| [Symbol] | Proposed Street |
| [Symbol] | Existing Street |
| [Symbol] | Proposed Utility |
| [Symbol] | Existing Utility |
| [Symbol] | Proposed Landscape |
| [Symbol] | Existing Landscape |

NOTES

1. ALL DIMENSIONS ARE IN FEET AND INCHES.
2. ALL DIMENSIONS ARE TO FACE UNLESS OTHERWISE NOTED.
3. ALL DIMENSIONS ARE TO CENTERLINE UNLESS OTHERWISE NOTED.
4. ALL DIMENSIONS ARE TO CENTERLINE UNLESS OTHERWISE NOTED.
5. ALL DIMENSIONS ARE TO CENTERLINE UNLESS OTHERWISE NOTED.
6. ALL DIMENSIONS ARE TO CENTERLINE UNLESS OTHERWISE NOTED.
7. ALL DIMENSIONS ARE TO CENTERLINE UNLESS OTHERWISE NOTED.
8. ALL DIMENSIONS ARE TO CENTERLINE UNLESS OTHERWISE NOTED.
9. ALL DIMENSIONS ARE TO CENTERLINE UNLESS OTHERWISE NOTED.
10. ALL DIMENSIONS ARE TO CENTERLINE UNLESS OTHERWISE NOTED.

SITE PLAN



Nature Tech

LANDSCAPING INC.
GENERAL ENGINEERING CONTRACTOR



1760 MARLBOROUGH AVE. RIVERSIDE, CA. 92507 PHONE - 951-684-8808 FAX -951-779-1064

CHANGE ORDER PROPOSAL

COP # 12
JOB# 2011

DATE 1/17/2013

JOB: 2011

Cabazon

Doug Wall Construction

DESCRIPTION: Added Sod Building B

Exclusions: out of sequence maintenance/extended maintenance period past installation date

| LABOR | | | | | |
|----------------------------------|------------------------|----------|----------|---------|--------------------|
| CLASSIFICATION | REG HOURS | REG RATE | OT HOURS | OT RATE | COST |
| Labor @ Hydroseed | -1 | 53.35 | | | \$ (53.35) |
| Labor @ Sod | 14 | 53.35 | | | \$ 746.90 |
| | | | | | \$ - |
| SUB TOTAL | | | | | \$ 746.90 |
| EQUIPMENT/SUBCONTRACTOR | | | | | |
| DESCRIPTION | REG HOURS | REG RATE | | | COST |
| Ride on Trencher | 1 | 55 | | | \$ 55.00 |
| | | | | | \$ - |
| SUB TOTAL | | | | | \$ 55.00 |
| MATERIAL | | | | | |
| DESCRIPTION | QTY | UNITS | COST | | |
| Hydro Seed | -2600 | SF | 0.19 | | \$ (494.00) |
| Sod | 2600 | SF | 0.33 | | \$ 846.30 |
| SUB TOTAL | | | | | \$ 352.30 |
| Customer Acceptance: | | | | | |
| By: | TOTAL COST | | | | \$ 1,154.20 |
| Date: | OVERHEAD/PROFIT | | | 15% | \$ 173.13 |
| NATURE TECH LANDSCAPING : | SUB TOTAL | | | | \$ 1,327.33 |
| By: | BOND | | | 1% | \$13.27 |
| Date: | COMBINED TOTAL | | | | \$ 1,340.60 |

Sent: Thursday, January 10, 2013 8:57 AM

To: Anthony Labriola

Subject: Re: CABAZON - LIBRARY BLDNG

Elite plus is best as it stays green year around. The price delivered is \$.2847 per sq ft

Brett Hill

Director of Sales

A-G Sod Farms



DOUG WALL CONSTRUCTION, INC.
CA 9C LK # 743112

| | |
|-------------|---|
| PENDING | X |
| Approved | |
| OWNER | X |
| SUBCONTRACT | |
| Internal | |

PROPOSED CHANGE ITEM

PROJECT: Cabazon Civic Center

Proposed Change Number 175

RFP #

DATE: 1/19/2013

TO: Dominick Lombardi
Tom Howell

COST CODE:

JOB # 1032

The Original Construction Agreement is hereby modified and amended by the following deviations from original plans and specifications:

1. Added General Conditions

\$98,656.00

| | |
|----------------------------|-------------|
| Subtotal | \$98,656.00 |
| Profit and Overhead 5% | |
| Subtotal | |
| Bonding and Insurance 1.5% | |
| Total | |

Original Contract Amount

| | |
|--------------------------------|---------|
| Total Previous Change Orders | _____ |
| Total Before this Change Order | _____ |
| Amount of this Change Order | Pending |
| Revised Contract Amount: | _____ |

\$98,656.00

47,328

Riverside County EDA

SIGNED: _____
 DATED: _____
 TITLE: _____

Architect:
 SIGNED: _____
 DATED: _____
 TITLE: _____

DOUG WALL CONSTRUCTION INC.

SIGNED: _____
 DATED: _____
 TITLE: _____

APPROVED ON
 THIS C.O.
 AND THE
 OTHER HALF
 APPROVED ON
 C.O. #17



DOUG WALL CONSTRUCTION, INC.

CA St. Lic #743112

12/27/2012

County of Riverside Economic Development Agency
3403 10th St. # 500
Riverside, CA92501

RE: Cabazon Community Center Extended General Requirements

Mr. Dominick Lombardi

We are submitting a list of overhead for your review for the extended GC's.

| | | |
|----------------------|-----------|----------|
| Supervision | 3,600.00 | Per week |
| Temporary Facilities | 400.00 | Per Week |
| Security | 696.00 | Per week |
| Temporary Fence | 200.00 | Per week |
| PM-10 | 400.00 | Per week |
| Progresive Clean up | 870.00 | Per week |
| Total Per Week | 6,166.00 | |
| 16 Weeks Extended | 16 | Weeks |
| Total Extended GC's | 98,656.00 | |

Doug Wall

President



DOUG WALL CONSTRUCTION, INC.
CA ST. Lic # 743112

PROPOSED CHANGE ITEM

| | |
|-------------|---|
| PENDING | X |
| Approved | |
| OWNER | X |
| SUBCONTRACT | |
| Internal | |

PROJECT: Cabazon Civic Center

Proposed Change Number 176

RFP #

DATE: 1/19/2013

TO: Dominick Lombardi
Tom Howell

COST CODE:

JOB # 1032

The Original Construction Agreement is hereby modified and amended by the following deviations from original plans and specifications:

Regrading at Location of RFI 321 Response **\$936.00**

| | |
|----------------------------|----------|
| Subtotal | \$936.00 |
| Profit and Overhead 5% | \$47.00 |
| Subtotal | \$983.00 |
| Bonding and Insurance 1.5% | \$15.00 |
| Total | \$998.00 |

| | |
|--------------------------------|---------------|
| Original Contract Amount | _____ |
| Total Previous Change Orders | _____ |
| Total Before this Change Order | _____ |
| Amount of this Change Order | Pending _____ |
| Revised Contract Amount: | _____ |

Riverside County EDA
 SIGNED: _____
 DATED: _____
 TITLE: _____

DOUG WALL CONSTRUCTION INC.
 SIGNED: _____
 DATED: _____
 TITLE: _____

Architect:
 SIGNED: _____
 DATED: _____
 TITLE: _____



12831 Moreno Beach Dr. #107-181
 Moreno Valley, Ca 92555

Invoice

| | |
|--------|-----------|
| Date | Invoice # |
| 1-3-13 | 3140-191 |

Bill To
 Doug Wall
 78450 Ave. 41
 Bermuda Dunes, Ca. 92203

| | | P.O. No. | Terms | Project/Job |
|----------|---|--------------|--------|-----------------|
| | | 1032C amazon | Net 30 | Civic Center |
| Quantity | Description | Rate | | Amount |
| | Civic Center T & M Work to regrade at area south of Bldg A | | | |
| 5.5 | Grade Checker 8 hours @ \$75.00 | 75.00 | | \$523.00 |
| 5.5 | Skip Loader 1 hour @ \$95.00 | 95.00 | | \$413.00 |
| | | Total | | \$936.00 |

APR 2011
 Road 201-F-2
 CIVIC
 1055000

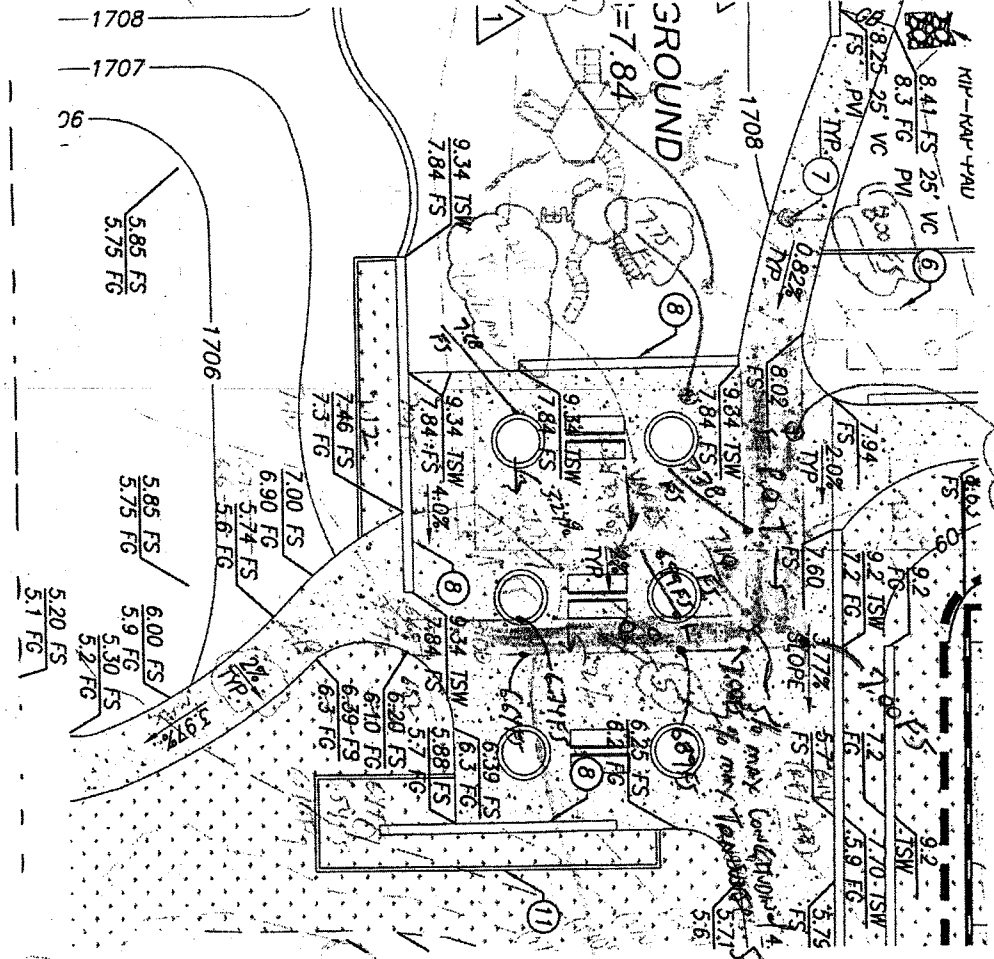

12-17-2012
 8604-5
 A 1' 20'

APR 2011

4.9% (approx)
 1010 (approx)
 (Class - 5000)

P.O.T.

Stable (East)

7.84 FS



DOUG WALL CONSTRUCTION, INC.
CALIFORNIA LICENSE # 34312

PROPOSED CHANGE ITEM

| | |
|-------------|---|
| PENDING | X |
| Approved | |
| OWNER | X |
| SUBCONTRACT | |
| Internal | |

PROJECT: Cabazon Civic Center

Proposed Change Number 177

RFP #

DATE: 1/24/2013

TO: Dominick Lombardi
Tom Howell

COST CODE:

JOB # 1032

The Original Construction Agreement is hereby modified and amended by the following deviations from original plans and specifications:

Remove/Add Bus Stop Sign/Paint Curb Red \$395.00

| | |
|----------------------------|----------|
| Subtotal | \$395.00 |
| Profit and Overhead 5% | \$20.00 |
| Subtotal | \$415.00 |
| Bonding and Insurance 1.5% | \$6.00 |
| Total | \$421.00 |

| | |
|--------------------------------|---------------|
| Original Contract Amount | _____ |
| Total Previous Change Orders | _____ |
| Total Before this Change Order | _____ |
| Amount of this Change Order | Pending _____ |
| Revised Contract Amount: | _____ |

Riverside County EDA
SIGNED: _____
DATED: _____
TITLE: _____

DOUG WALL CONSTRUCTION INC.
SIGNED: _____
DATED: _____
TITLE: _____

Architect:
SIGNED: _____
DATED: _____
TITLE: _____

STRIPELINE COMPANY

WWW.PARKINGLOTSTRIPING.ORG

| |
|---|
| PO BOX 43 CALIMESA, CA 92320 PHONE (909) 583-7362 FAX (909) 795-2330 / BID FAX (951) 769-1144 STRIPELINECOMPANY@VERIZON.NET |
| CONTRACTOR: |
| D.W.C. INC. 78450 AVE. 41 BERMUDA DUNES, CA 92203 (F)760-772-9407 |

| | | |
|-------------------------------------|-------------------|------------|
| CA LICENSE # 917965 | | |
| Date | Estimate # | Rep |
| 1/24/2013 | 9522 | |
| PROJECT LOCATION: | | |
| CABAZON CIVIC CENTER CABAZON, CA | | |

| ITEMS | Qty | Amount | Total |
|---|-----|--|-----------------------|
| CONTRACT # 1032<<EXTRA WORK ORDER>> | | | |
| Paint Curb: Red w/"NO PARKING FIRE LANE" | 85 | 1.00 | 85.00 |
| REMOVE & REPAIR EXISTING SIGN | 1 | 150.00 | 150.00 |
| INSTALL EX. SIGN PLAQUE ON NEW POST & ANCHOR. | 1 | 160.00 | 160.00 |
| THANK YOU. | | <i>This estimate is valid for 180 days</i> | Total \$395.00 |

NO CHANGES CAN BE MADE TO THIS ESTIMATE/BID WITHOUT THE APPROVAL OF STRIPELINE Co.

Acceptance Signature/Date



DOUG WALL CONSTRUCTION, INC.
CA SL LK # 7-0112

PROPOSED CHANGE ITEM

| | |
|-------------|---|
| PENDING | X |
| Approved | |
| OWNER | X |
| SUBCONTRACT | |
| Internal | |

PROJECT: Cabazon Civic Center

Proposed Change Number 178

RFP #

DATE: 1/26/2012

TO: Dominick Lombardi
Tom Howell

COST CODE:

JOB # 1032

The Original Construction Agreement is hereby modified and amended by the following deviations from original plans and specifications:

- | | |
|---|---------------|
| 1. (a) Credit for 50% plant reduction | (\$36,417.00) |
| (b) Credit for P/O/Bonding/Ins on (2a) at 5.5% | (\$2,003.00) |
| 2. (a) Add Pro Sport Ultra Seed/ Delete Stolons | \$17,928.00 |
| (b) P/O/Bonding/Ins on 3a at 6.5% | \$1,165.00 |

| | |
|----------------------------|---------------|
| Subtotal | (\$19,327.00) |
| Profit and Overhead 5% | |
| Subtotal | |
| Bonding and Insurance 1.5% | |
| Total | |

Original Contract Amount

| | |
|--------------------------------|-----------------------|
| Total Previous Change Orders | _____ |
| Total Before this Change Order | _____ |
| Amount of this Change Order | Pending (\$19,327.00) |
| Revised Contract Amount: | _____ |

Riverside County EDA

SIGNED: _____
DATED: _____
TITLE: _____

DOUG WALL CONSTRUCTION INC.

SIGNED: _____
DATED: _____
TITLE: _____

Architect:

SIGNED: _____
DATED: _____
TITLE: _____



Nature Tech



LANDSCAPING INC.
GENERAL ENGINEERING CONTRACTOR

1780 MARLBOROUGH AVE. RIVERSIDE, CA. 92507 PHONE - 951-684-3888 FAX - 951-775-1064

CHANGE ORDER PROPOSAL COP# DATE 07/02/12
 JOB: 2011 JOB# Add Days
 Calson
 Doug Wall Construction
 DESCRIPTION: 50% reduction in planting
 Delete 3 gal oak 1 gal shrubs
 DATE WORK PERFORMED:

| LABOR | | | | | |
|-----------------------|-----------|----------|----------|---------|---------------|
| CLASSIFICATION | REG HOURS | REG RATE | OT HOURS | OT RATE | COST |
| Credit Labor @ Shrubs | -79 | 53.35 | | | \$ (4,214.85) |
| | | | | | \$ - |
| | | | | | \$ - |
| SUB TOTAL | | | | | \$ - |

| EQUIPMENT | | | | | |
|------------------|-----------|----------|--|--|------|
| DESCRIPTION | REG HOURS | REG RATE | | | COST |
| | | | | | \$ - |
| | | | | | \$ - |
| SUB TOTAL | | | | | \$ - |

| MATERIAL | | | | | |
|---|-----|-------|----------|--|---------------|
| DESCRIPTION | QTY | UNITS | COST | | |
| 50% Planting reduction - 3 gal total shrubs | -1 | LS | 8,825.00 | | \$ (8,825.00) |
| | | | | | \$ - |
| | | | | | \$ - |
| | | | | | \$ - |
| | | | | | \$ - |
| | | | | | \$ - |
| SUB TOTAL | | | | | \$ - |

| | | | | | |
|---------------------------|--|------------------|-----|--|----------------|
| Customer Acceptance: | | | | | |
| By: | | TOTAL COST | | | \$ (12,839.85) |
| Date: | | OVER-HEAD/PROFIT | 15% | | \$ (1,925.98) |
| NATURE TECH LANDSCAPING : | | SUB TOTAL | | | \$ (14,765.83) |
| By: | | BOND | 1% | | \$ (147.66) |
| Date: | | COMBINED TOTAL | | | \$ (14,913.49) |

1/4 377.00

3588.0
 J.M.A.L.
 MATERIAL
 3635.40
 4785.00
 36,067.00
 366.00
 36,417.00



1790 MARLBOROUGH AVE. RIVERSIDE, CA. 92507 PHONE - 951-684-8808 FAX -951-779-1064

CHANGE ORDER PROPOSAL

COP # 7
JOB# 2011

DATE 10/22/2012

JOB: 2011

Cabazon

Doug Wall Construction

DESCRIPTION: Delete pro-sport seed

Install Pro-Sport - Ultra seed

| LABOR | | | | | |
|----------------------------------|-----------|----------|-----------------|---------|----------------|
| CLASSIFICATION | REG HOURS | REG RATE | OT HOURS | OT RATE | COST |
| | | 53.35 | | | \$ - |
| SUB TOTAL | | | | | \$ - |
| EQUIPMENT/SUBCONTRACTOR | | | | | |
| DESCRIPTION | REG HOURS | REG RATE | | | COST |
| | | | | | \$ - |
| SUB TOTAL | | | | | \$ - |
| MATERIAL | | | | | |
| DESCRIPTION | QTY | UNITS | COST | | |
| Stolons | -147000 | SF | 0.08 | | \$ (11,760.00) |
| Ultra Turf HydroSeed | 147000 | SF | 0.19 | | \$ 27,195.00 |
| SUB TOTAL | | | | | \$ 15,435.00 |
| Customer Acceptance: | | | | | |
| By: | | | TOTAL COST | | \$ 15,435.00 |
| Date: | | | OVERHEAD/PROFIT | 15% | \$ 2,315.25 |
| NATURE TECH LANDSCAPING : | | | SUB TOTAL | | \$ 17,750.25 |
| By: | | | BOND | 1% | \$177.50 |
| Date: | | | COMBINED TOTAL | | \$ 17,927.75 |



DOUG WALL CONSTRUCTION, INC.
CA 92582-7412

| | |
|-------------|---|
| PENDING | X |
| Approved | |
| OWNER | X |
| SUBCONTRACT | |
| Internal | |

PROPOSED CHANGE ITEM

PROJECT: Cabazon Civic Center

Proposed Change Number 179

RFP #

DATE: 1/30/2013

TO: Dominick Lombardi
Tom Howell

COST CODE:

JOB # 1032

The Original Construction Agreement is hereby modified and amended by the following deviations from original plans and specifications:

Credit for Tack Boards (\$2,500.00)

| | |
|----------------------------|--------------|
| Subtotal | (\$2,500.00) |
| Profit and Overhead 4% | (\$100.00) |
| Subtotal | (\$2,600.00) |
| Bonding and Insurance 1.5% | (\$39.00) |
| Total | (\$2,639.00) |

| | |
|--------------------------------|----------------------|
| Original Contract Amount | _____ |
| Total Previous Change Orders | _____ |
| Total Before this Change Order | _____ |
| Amount of this Change Order | Pending (\$2,639.00) |
| Revised Contract Amount: | _____ |

Riverside County EDA
 SIGNED: _____
 DATED: _____
 TITLE: _____

DOUG WALL CONSTRUCTION INC.
 SIGNED: _____
 DATED: _____
 TITLE: _____

Architect:
 SIGNED: _____
 DATED: _____
 TITLE: _____



DOUG WALL CONSTRUCTION, INC.

Office: 760/772-9412
 78-450 Avenue 41
 Bermuda Dunes, CA 92203
 760/772-8446 • 760/772-9407

INVOICE #: 4175
INVOICE DATE: 12/31/12
PERIOD TO: 12/31/12
APPLICATION #: 18
CONTRACT DATE:
DUE DATE: 01/30/13
PAGE: 2

BILL TO: 166

The Redevelopment Agency For
 The County of Riverside
 3403 Tenth St. 4th Floor
 Riverside, CA 92501

JOB: 1032

Cabazon Civic Center
 Site Bordered by Broadway,
 Carmen & Irene Street
 Cabazon, CA

<<< This Application >>>

| CODE | DESCRIPTION | SCHEDULED VALUE | PREVIOUS APPLICATIONS | CURRENT COMPLETED | STORED MATERIALS | TOTAL COMPLETED | % COMPL | BALANCE TO FINISH | RETAINAGE |
|------|-----------------------|-----------------|-----------------------|-------------------|------------------|-----------------|---------|-------------------|-----------|
| 3140 | Metal Roofing A | 223,210.00 | 223,210.00 | | | 223,210.00 | 100.0 | | 11,160.50 |
| 3141 | Rough Carpentry A | 529,300.00 | 529,000.00 | | | 529,300.00 | 100.0 | | 26,450.00 |
| 3142 | Casework A | 96,270.00 | 96,270.00 | | | 96,270.00 | 100.0 | | 4,813.50 |
| 3143 | Roof Cover A | 32,175.00 | 32,175.00 | | | 32,175.00 | 100.0 | | 1,608.75 |
| 3144 | Insulation A | 24,748.00 | 24,748.00 | | | 24,748.00 | 100.0 | | 1,237.40 |
| 3145 | Waterproofing A | 12,000.00 | 12,000.00 | | | 12,000.00 | 100.0 | | 600.00 |
| 3147 | SiteWallWaterproof A | 20,000.00 | 20,000.00 | | | 20,000.00 | 100.0 | | 1,000.00 |
| 3148 | Sealants Caulking A | 1,800.00 | 1,800.00 | | | 1,800.00 | 100.0 | | 90.00 |
| 3149 | Door/Frame/Entrance | 94,100.00 | 94,100.00 | | | 94,100.00 | 100.0 | | 4,705.00 |
| 3149 | Glazing Windows A | 310,564.00 | 310,564.00 | | | 310,564.00 | 100.0 | | 15,528.20 |
| 3149 | Door & Plaster A | 70,000.00 | 70,000.00 | | | 70,000.00 | 100.0 | | 3,500.00 |
| 3149 | W/P A | 9,200.00 | 9,200.00 | | | 9,200.00 | 100.0 | | 460.00 |
| 3150 | Shower Tric A | 41,912.00 | 41,912.00 | | | 41,912.00 | 100.0 | | 2,095.60 |
| 3152 | Resinous Flooring A | 10,573.00 | 10,573.00 | | | 10,573.00 | 100.0 | | 528.65 |
| 3153 | Carpet A | 36,600.00 | | 36,600.00 | | 36,600.00 | 100.0 | | 1,830.00 |
| 3153 | Painting A | 53,000.00 | 53,000.00 | | | 53,000.00 | 100.0 | | 2,650.00 |
| 3155 | Brickwall A | 62,655.00 | 62,655.00 | | | 62,655.00 | 100.0 | | 3,132.75 |
| 3156 | 1 Bar A | 220,000.00 | 220,000.00 | | | 220,000.00 | 100.0 | | 11,000.00 |
| 3157 | Blinds A | 3,916.00 | | | | | 0.0 | 3,916.00 | |
| 3158 | Visual Display Board | 2,500.00 | 2,500.00 | | | 2,500.00 | 100.0 | | 125.00 |
| 3159 | Storage A | 16,000.00 | 16,000.00 | | | 16,000.00 | 100.0 | | 800.00 |
| 3160 | Fire extinguishers A | 1,500.00 | 1,500.00 | | | 1,500.00 | 100.0 | | 75.00 |
| 3161 | Operable Partitions A | 10,700.00 | 6,955.00 | 3,745.00 | | 10,700.00 | 100.0 | | 535.00 |
| 3162 | Restrictd Access A | 8,535.00 | 8,535.00 | | | 8,535.00 | 100.0 | | 426.75 |
| 3163 | Skate Park | 218,195.00 | 218,195.00 | | | 218,195.00 | 100.0 | | 10,909.75 |
| 3164 | Food Dry Equip A | 163,439.00 | 163,439.00 | | | 163,439.00 | 100.0 | | 8,171.95 |
| 3165 | Residential Equip A | 7,500.00 | 7,500.00 | | | 7,500.00 | 100.0 | | 375.00 |
| 3166 | Shade Structure | 67,450.00 | | | | | 0.0 | 67,450.00 | |
| 3167 | Plumbing Rough A | 142,725.00 | 142,725.00 | | | 142,725.00 | 100.0 | | 7,136.25 |
| 3168 | Plumbing Finish A | 73,075.00 | 73,075.00 | | | 73,075.00 | 100.0 | | 3,653.75 |
| 3169 | HVAC Rough A | 210,560.00 | 210,560.00 | | | 210,560.00 | 100.0 | | 10,528.00 |
| 3170 | HVAC Equipment A | 97,750.00 | 97,750.00 | | | 97,750.00 | 100.0 | | 4,886.00 |
| 3171 | HVAC Finish A | 67,680.00 | 67,680.00 | | | 67,680.00 | 100.0 | | 3,384.00 |
| 3172 | Fire Sprinklers A | 43,914.00 | 43,914.00 | | | 43,914.00 | 100.0 | | 2,195.70 |
| 3173 | Electrical Rough A | 380,100.00 | 380,100.00 | | | 380,100.00 | 100.0 | | 19,005.00 |
| 3174 | Electrical Finish A | 162,900.00 | 162,900.00 | | | 162,900.00 | 100.0 | | 8,145.00 |
| 3175 | Supervision | 190,000.00 | 190,000.00 | | | 190,000.00 | 100.0 | | 9,500.00 |