

328A



SUBMITTAL TO THE BOARD OF SUPERVISORS COUNTY OF RIVERSIDE, STATE OF CALIFORNIA

FROM: TLMA – Transportation Department

SUBMITTAL DATE:
October 24, 2013

SUBJECT: Approval of the Plans and Specifications for the Avenida Florencita Sidewalk Construction Project, in the Southeast Desert Hot Springs Community, 4th/4th District (Clerk to Advertise) [\$168,000, State Funds 49.8%, Local Funds 50.2%]

RECOMMENDED MOTION: That the Board of Supervisors:

1. Approve the plans and specifications for the construction of Avenida Florencita sidewalk project and associated improvements in the Southeast Desert Hot Springs community; and
2. Authorize the Clerk of the Board to advertise for bids to be received in the office of the Director of Transportation and Land Management up to the hour of 2:00 p.m., Wednesday, December 4, 2013, at which time bids will be opened.

Juan C. Perez
Director of Transportation and Land Management

JCP: jrj:rr

Departmental Concurrence

FORM APPROVED COUNTY COUNCIL
BY: U. B. Keener 10/17/13
MAYOR VICTOR DATE

FINANCIAL DATA	Current Fiscal Year:	Next Fiscal Year:	Total Cost:	Ongoing Cost:	POLICY/CONSENT (Per Exec. Office)
COST	\$ 168,000	\$ 0.00	\$ 168,000	\$ 0.00	Consent <input type="checkbox"/> Policy <input checked="" type="checkbox"/>
NET COUNTY COST	\$ 0.00	\$ 0.00	\$ 0.00	\$ 0.00	

SOURCE OF FUNDS: SB 821 [Local Transportation Funds] (49.8%) and Measure A/Coachella Valley (50.2%).
There are no General Funds used in this project.

Budget Adjustment: No
For Fiscal Year: 2013/2014

C.E.O. RECOMMENDATION:

APPROVE

BY: Tina Grande
Tina Grande

County Executive Office Signature

MINUTES OF THE BOARD OF SUPERVISORS

On motion of Supervisor Jeffries, seconded by Supervisor Ashley and duly carried, IT WAS ORDERED that the above matter is approved as recommended.

Ayes: Jeffries, Tavaglione, Stone and Ashley
Nays: None
Absent: Benoit
Date: November 5, 2013
xc: Transp. COB

Kecia Harper-Ihem
 Clerk of the Board
 By: Kecia Harper-Ihem
 Deputy

- A-30
- Positions Added
- 4/5
- Change Order
- Vote

Prev. Agn. Ref.: 11/13/13 **District:** 4th/4th **Agenda Number:**

3-58

SUBMITTAL TO THE BOARD OF SUPERVISORS, COUNTY OF RIVERSIDE, STATE OF CALIFORNIA
FORM 11: Approval of the Plans and Specifications for the Avenida Florencita Sidewalk Construction Project,
in the Southeast Desert Hot Springs Community, 4th/4th District (Clerk to Advertise) [\$168,000, State Funds
49.8%, Local Funds 50.2%]

DATE: October 24, 2013

PAGE: 2 of 2

BACKGROUND:

Summary

Avenida Florencita provides a significant pedestrian link between Bubbling Wells Elementary School and the westerly residential area. Avenida Florencita currently contains obstructions to pedestrians use, such as fences, trees, signs, and parked vehicles. This project proposes to construct approximately 2,500 linear feet of sidewalk on the east side of Avenida Florencita to provide a safer pedestrian path.

The submitted plans and specifications have been approved as to form by County Counsel, and environmental clearance is complete.

Impact on Citizens and Businesses

The proposed improvements will improve pedestrian safety and provide an Americans with Disabilities Act (ADA) compliant path.

SUPPLEMENTAL:

Additional Fiscal Information

The construction contract is estimated to cost approximately \$168,000, and construction is expected to finish in FY 2013/2014 and will be funded with Measure A/Coachella Valley funds and with SB-821 funds, for which the County successfully completed.

Contract History and Price Reasonableness

N/A

Project Number: C3-0050

COUNTY OF RIVERSIDE
DEPARTMENT OF TRANSPORTATION

SIDEWALK PROJECT ON
AVENIDA FLORENCITA

CAMINO AVENTURA TO CAMINO CAMPANERO

PROJECT No. C3-0050

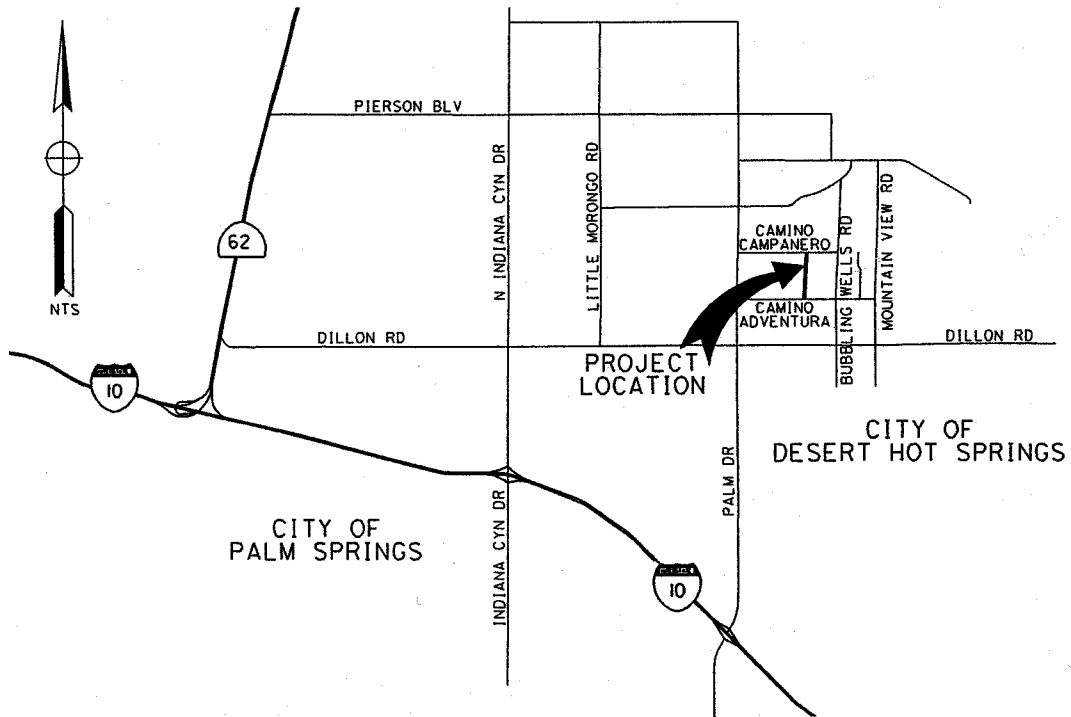
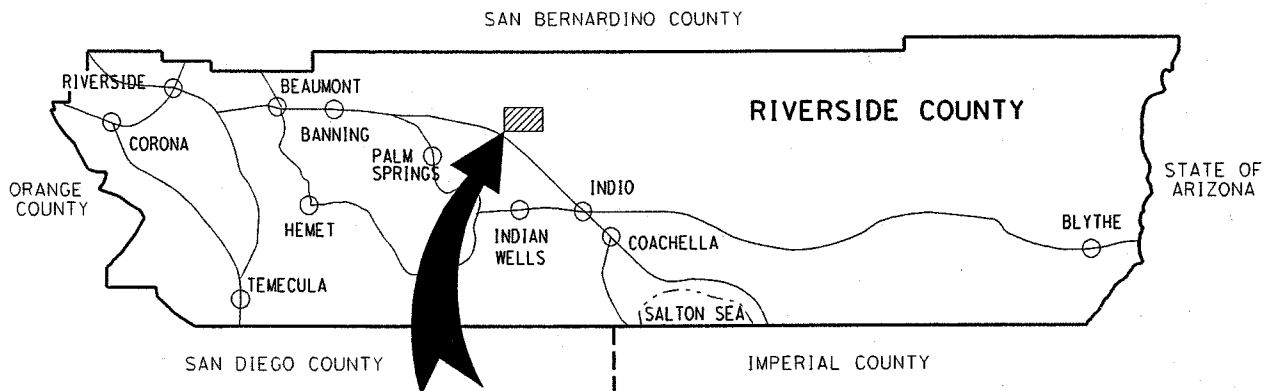

VICINITY MAP

TOWNSHIP 38 RANGE 5E SECTION 5
COUNTY ROAD BOOK PAGE No. 171

SPECIFICATIONS and CONTRACT DOCUMENTS

for the CONSTRUCTION

of

**Avenida Florencita
Sidewalk Project
Between Camino Aventura and Camino Campanero
Project No. C3-0050**

In the Southeast Desert Hot Springs Community



TRANSPORTATION DEPARTMENT

FORM APPROVED COUNTY COUNSEL

BY: Marshall Victor 10/17/13
MARSHA L. VICTOR DATE

General

Table of Contents

<u>Description</u>	<u>Page</u>
Vicinity Map	i
Specifications and Contract Documents Approvals	ii – iii
Notice To Bidders	iv
Instruction to Bidders*	A1 – A12
Bidding Documents	
Bid	B1
Bid Items	B2
Bidder Data and Signature	B3 – B4
Subcontractor List	B5
Non-Collusion Declaration	B6
Iran Contracting Act	B7
Bid Bond	B8
Contract and other Bonds	
Contract	C1 – C3
Performance Bond	C4
Payment Bond	C5

* **Note:** See the first page of this document description for a detailed Table of Contents.

**General
Table of Contents (continued)**

General Conditions*	GC1 – GC29
Special Provisions*	1 – 28
Appendices	
AQMD Recommendations*	Appendix A
Reference Drawings	Appendix B

*** Note:** See the first page of this document description for a detailed Table of Contents.

C O U N T Y O F R I V E R S I D E
D E P A R T M E N T O F T R A N S P O R T A T I O N

**Avenida Florencita
Sidewalk Project
Between Camino Aventura and Camino Campanero
Project No. C3-0050**

In the Southeast Desert Hot Springs Community

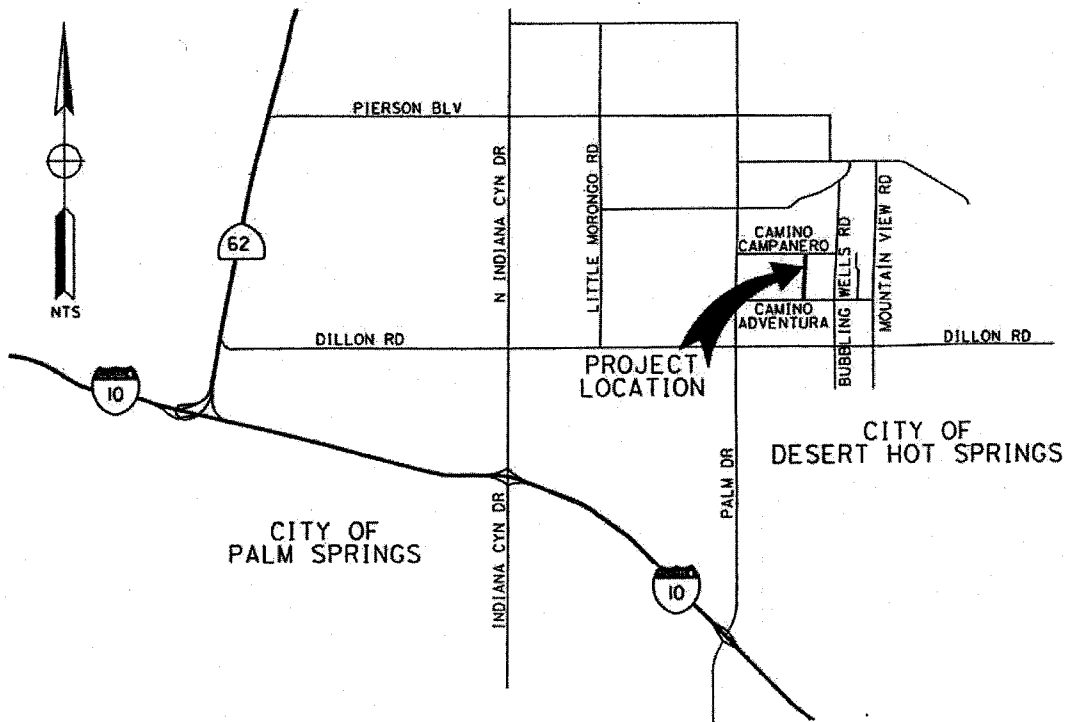
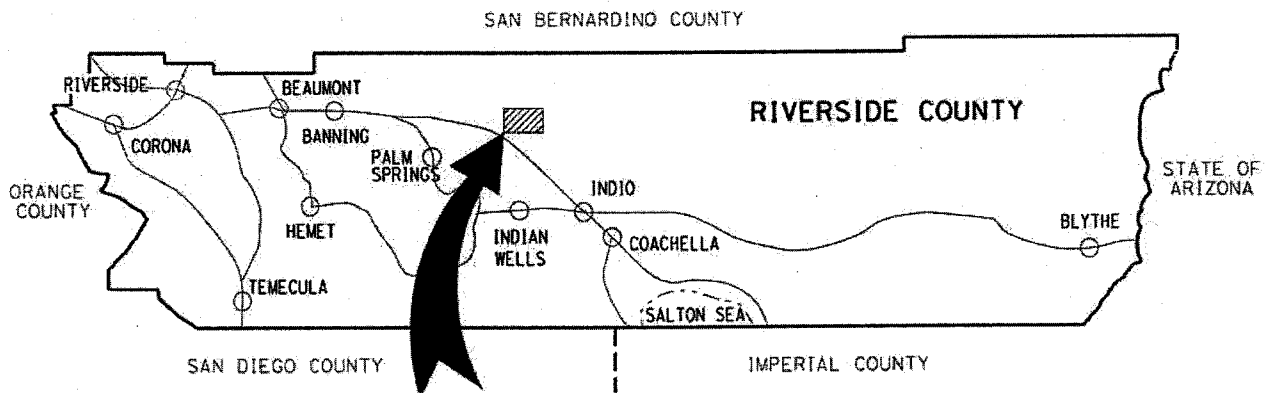

VICINITY MAP
TOWNSHIP 3S RANGE 5E SECTION 5
COUNTY ROAD BOOK PAGE No. 171

Specification and Contract Documents

for the construction of

**Avenida Florencita
Sidewalk Project**

**Between Camino Aventura and Camino Campanero
Project No. C3-0050**

In the Southeast Desert Hot Springs Community

Contract Approval(s)

Approval:

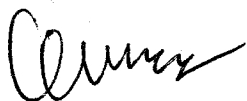

10/1/13

Khalid Nasim, PE
Engineering Division Manager

Date

Engineering Certification(s)

These specifications, special provisions, and estimates have been prepared by or under the direction of the following Registered Civil Engineer(s):

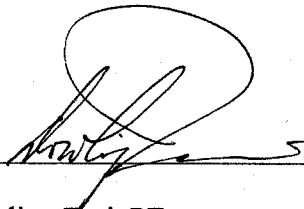

Dowling Tsai, PE

10/1/2013

Date

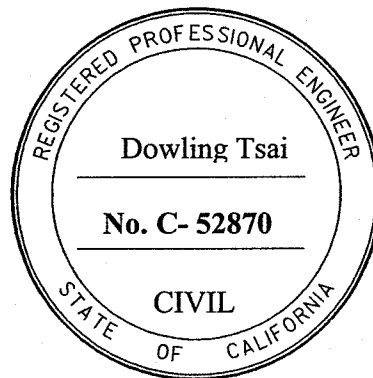

Specification and Contract Documents

for the construction of

Avenida Florencita

Sidewalk Project

Between Camino Aventura and Camino Campanero

Project No. C3-0050

In the Southeast Desert Hot Springs Community

Water Pollution Control – Specifications and Special Provisions

Reviewed and Recommended by:

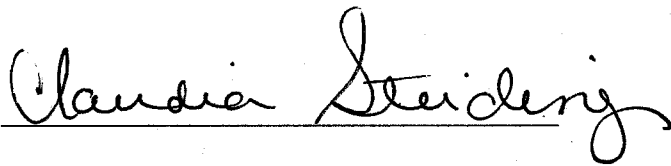

Claudia Steiding
Senior Transportation Planner/NPDES
Coordinator

9/12/13
Date

Notice to Bidders

County of Riverside, herein called Owner, invites sealed proposals for:

**Avenida Florencita
Sidewalk Project
Between Camino Aventura and Camino Campanero
Project No. C3-0050**

In the Southeast Desert Hot Springs Community

Bid shall be delivered to the County of Riverside Transportation Department, 14th Street Annex, 3525 14th Street, Riverside, California 92501, telephone (951) 955-6780 not later than 2:00 p.m., on Wednesday, **December 4, 2013** to be promptly opened in public at said address. Each bid shall be in accordance with plans, specifications and other contract documents, dated **September 2013**, and prepared by County of Riverside, whose address is same as the above, from whom they may be obtained upon deposit of **\$30.00** per set with 24" x 36" plans, plus mailing costs. No refund. Prospective bidders may preview the plans, specifications and other contract documents at no charge prior to purchase at the above noted location.

The Contractor is required to have a Class "A" or C12 (Earthwork and Paving) license at the time of bid submission.

Engineering Estimate	
Base Bid:	\$ 152,000 - \$ 184,500
Bid Bond	10 %
Performance Bond	100 %
Payment Bond	100 %
Working Days	40 Working Days
Website:	http://www.rctlma.org/trans/con_bid_advertisements.html

Instructions to Bidders

Table of Contents

1.	Inspection of Site	A 2
2.	Bidder's Bid Form	A 2
3.	Bid Bond	A 2
4.	Non-Collusion Declaration	A 3
5.	Iran Contracting Act, Certification or Exemption	A 3
6.	Interpretation of Documents	A 3
7.	Quantities	A 4
8.	Addenda	A 4
9.	License	A 4
10.	Contract Participation	A 5
11.	Subletting, Subcontracting, and Subcontractor List	A 5
12.	Hours of Work	A 6
13.	Alternate Bid Schedules.....	A 6
14.	Bids	A 7
15.	Like Bid Items.....	A 8
16.	Contract Documents.....	A 9
17.	Submission of Bidder's Bid.....	A 9
18.	Qualifications of Bidders	A 9
19.	Design Engineer May Not Bid On Construction Contract:	A 9
20.	Award of Contract.....	A 9
21.	Payment and Performance Bonds	A 11
22.	Return of Bid Guarantee	A 12
23.	Submission of Insurance Certificate and Endorsements.....	A 12

Instructions to Bidders

The Bidder's attention is directed to the provisions in Section 2, "Proposal Requirements and Conditions" of the Standard Specifications and Contract Documents, including the Plans and the Special Provisions, for the requirements and conditions which the bidder must observe in the preparation of and the submission of the Bid.

1. Inspection of Site

Bidders must examine the site and acquaint themselves with all conditions affecting the work. By making and submitting a bid, a Bidder warrants that he has made such site examination as the Bidder deems necessary for the condition of the site, its accessibility for materials, workmen and utilities, and for the ability to protect existing surface and subsurface improvements. No claim for allowances, time or money, will be allowed as to such matters.

2. Bidder's Bid Form

The Bid must be made on the Bid forms, which are included in the Contract Documents, and must be completely filled in, dated and signed. If provision is made for alternate bid schedule(s), all bid schedules must be bid, unless otherwise instructed in the Special Provisions.

The first sentence of the second paragraph in Section 2-1.05, "Proposal Forms" of the Standard Specifications is amended to read:

The Bid form is bound together with the Contract.

All Bid forms shall be obtained from the Riverside County Transportation Department, 3525 14th Street, Riverside, California 92501.

3. Bid Bond

The bidder's bond form described in the last paragraph in Section 2-1.07, "Proposal Guaranty" of the Standard Specifications and this section will be found in the Bid Book's "B" pages and this form is titled as "Bid Bond".

The Bid must be accompanied by a 10% Bid Bond using the form provided in the Bid Book, or a certified check, or cashier's check payable to the order of "County of Riverside", in an amount not less than 10% of the bid amount, inclusive of alternate bid schedule(s). Submitted Bid Bond form must be completely filled in, sealed, dated and signed. Signatures on the Bid Bond must be notarized. Bond shall be provided with an executed Power of Attorney issued by the surety.

4. Non-Collusion Declaration

In conformance with Public Contract Code §7106, a Non-Collusion Declaration is included in the Bid. Bidder Declaration must be submitted using the form provided in the Bid Book and it must be completely filled in, dated and signed. Signatures on the Non-Collusion Declaration must be notarized.

5. Iran Contracting Act, Certification or Exemption

The Department of General Services has published a list of companies who are prohibited from contracting with public entities in California as required by Public Contract Code §2200 through §2208.

The Iran Contracting Act Certification/Exemption form is included in the Bid Book. For projects estimated or Bid, in the amount of \$1,000,000 or more, Bidder must completely fill in, date, sign and submit this form with the Bid documents.

6. Interpretation of Documents

Discrepancies, omissions, ambiguities, requirements likely to cause disputes between trades and similar matters must be promptly brought to the attention of the County in writing. When appropriate, addenda will be issued by the County.

If the Bidder requires clarification or interpretation of the bidding Contract Documents, the Bidder must make a written request to the County by a Request for Information (RFI). All RFIs must be submitted in writing between the hours of 8:00 a.m. and 5:00 p.m., Monday through Thursday (except holidays), up to, including and no later than the fifth (5th) business day prior to the bid closing deadline, by hand delivery, mail, fax or electronic mail. The County will not respond to RFIs submitted after that time, unless the County determines at its sole discretion that it is in the best interest of the public and the County to do so. RFIs should be addressed and sent to:

County of Riverside
Transportation Department
Attention: Contracts/Bidding Unit
3525 14th Street
Riverside, CA 92501

Facsimile: (951) 955-3164
Electronic mail: jrjimenez@rctlma.org

Any communication by anyone as to RFIs and other project document inquiries, except by Addenda, does not affect the meaning or requirements of the Contract Documents.

7. Quantities

The amount of work to be done and/or materials to be furnished under the Contract, as shown in the Bid, are merely estimates and are not to be taken as an expressed or implied statement that the actual amount of work or materials will correspond to the estimate.

County reserves the right to increase, decrease or entirely eliminate any items from the work and/or materials to be furnished.

Bidders are cautioned against the unbalancing of their bid by prorating project overhead costs only into one, two, or few items when there are various items listed in the bid schedule(s).

The quantities mentioned in Standard Specifications Section 2-1.02, "Approximate Estimate" will be found in the Bid form.

8. Addenda

County reserves the right to issue Addenda to the Contract Documents at any time prior to the scheduled bid opening date and time. Each potential Bidder must provide the County his company name, contact name, phone number, facsimile number, electronic mail address and company address for the purpose of receiving Addenda.

To be considered responsive, the Bid must list and take into account all issued Addenda.

In addition to listing the acknowledged addenda (if any) on the Bid, Bidders should submit each addendum's acknowledgement signature page and attach each one to the Bid. Attaching all addenda pages and attachments (if any) to the Bid submittal is not necessary for Bid submittal. All Addenda is a component of the Contract Documents.

9. License

To be considered for award of the Contract, a Bidder must have the necessary license(s) required under provisions of the California Business and Professions Code for the scope of work covered in the Contract Documents at the time of bid submission. This includes Joint Ventures.

Each item of work will be performed by a Contractor that is qualified and properly licensed for that work.

Pursuant to California Labor Code §3099, certification is required for all persons who perform work as electricians for Contractors licensed as Class C10 "Electrical Contractor". Proof of certification must be provided to the County before the start of construction.

10. Contract Participation

County encourages general and prime Contractors to solicit competitive subcontracting, trucking and supplier opportunities to minority, women, disabled veteran, and small business firms where possible, in their contracting and procurement activities with the County.

11. Subletting, Subcontracting, and Subcontractor List

General

Attention is directed to General Conditions Section 5, "Subcontracting".

Pursuant to Public Contract Code § 4100 et seq., "Subletting and Subcontracting Fair Practices Act", Bidders are required to list each subcontractor who will perform work, provide labor, or render services in or about the construction of work or improvement or a subcontractor who specifically fabricates and installs a portion of the work or improvement according to the details contained in the Plans and Specifications. The Subletting and Subcontracting Fair Practice Act applies to all phases of the work.

Subcontractor List

As required by Standards Specification Section 2-1.054, "Required Listing of Proposed Subcontractors", the Bidder must submit a Subcontractor List. Subcontractor List must be on the form contained in the Bid Book.

Bidder must list each subcontractor to perform work, labor or render service in or about the construction in an amount in excess of 1/2 of 1 percent of the total bid or \$10,000, whichever is greater (Pub Cont Code § 4100 et seq.).

Pursuant to Public Contract Code § 6109 et seq., the Contractor shall not perform work on a project with a subcontractor who is ineligible to perform work on the project pursuant to Labor Code § 1777.1 or 1777.7.

The Subcontractor List must show the name, address, and work portions to be performed by each subcontractor listed. Work portions must be identified by bid item number and description for each subcontractor listed. If partial work is to be performed within a certain construction item or trade, the Bidder/Contractor shall specify the portions of the work to be performed by the different subcontractors or the directive under Public Contract Code § 4106 shall apply.

Each designated item of work will be performed by a Contractor which is qualified and properly licensed for that listed work.

Omission or failure to list a subcontractor for a portion of the work means that the prime Contractor will do that portion of the work (Public Contract Code § 4106).

The County may request additional information to verify submitted Subcontractor List information and percentage amounts. Bidder must provide this information within two (2) business days of request.

Penalties

The Bidder's attention is directed to other provisions of the Subletting and Subcontracting Fair Practices Act related to the imposition of penalties for failure to observe its provisions by utilizing unauthorized subcontractors or by making unauthorized substitutions.

Clerical error

After the Bid Opening, inadvertent subcontractor designation clerical error(s) will be processed as required by Public Contract Code § 4107.5.

12. Hours of Work

Attention is directed to Section 8-1.06, "Time of Completion" and Section 7-1.01A (1), "Hours of Labor" of the Standard Specifications.

Daily working hours will be between the hours of **7:00 a.m. and 6:00 p.m.**, Monday through Friday, except legal holidays, or as revised in the Special Provisions, and as approved by the Engineer. Exceptions and specific work schedules must be submitted in writing to the Engineer for consideration.

13. Alternate Bid Schedules

If the Bid includes bid items listed under a Base Bid Schedule and one or more Alternate Bid Schedules, the following will apply:

The County may award only the items of work listed on the Base Bid Schedule, or may choose to award some or all of the Alternate Bid Schedules in addition to the Base Bid Schedule. Unless otherwise specified, the basis of the selection of the lowest bid will be the lowest responsive and responsible bid for the sum of all Bid Schedules.

If the Bid includes bid items listed under two or more Alternate Bid Schedules with no Base Bid Schedule, the following will apply:

This project contains Alternate Bid Schedules that may or may not be mutually exclusive, as described elsewhere in the bid documents. The County may award the items of work

listed on one or more of the Alternate Bid Schedules. In the case of mutually exclusive Alternate Bid Schedules, only one of the Alternate Bid Schedules will be selected for award. Unless otherwise specified, the basis of the selection of the lowest bid will be the lowest responsive and responsible bid for the sum of all Bid Schedules.

The County reserves the right to reject all bids received.

14. Bids

No Bidder may withdraw their bid for a period of ninety (90) calendar days after the bid opening.

Bids are required for the entire work, including all alternate bid schedules, if applicable, unless otherwise explicitly allowed in the bid documents. The amount of the bid, for comparison purposes, will be the total of all items. The total of unit basis items will be determined by extension of the item price bid on the basis of the estimated quantity set forth for the item.

The Bidder must set forth for each item of work in clearly legible figures, an item price and a total for the item in the respective spaces provided for this purpose. In the case of unit basis items, the amount set forth under the "Total" column will be the extension of the item price bid on the basis of the estimated quantity for the item.

In the case of a discrepancy between the unit price and the total set forth for a unit basis item, the unit price will prevail, in (1) or (2), as follows:

1. If the amount set forth as a unit price is unreadable or otherwise unclear, or is omitted, or is the same as the amount as the entry in the item "Total" column, then the amount set forth in the item "Total" column for the item shall be divided by the estimated quantity for the item and the price thus obtained will be the unit price.
2. (Decimal Errors) If the product of the entered unit price and the estimated quantity is exactly off by a factor of ten, one hundred, etc., or one-tenth, or one-hundredth, etc. from the entered total, the discrepancy will be resolved by using the entered unit price or item total, whichever most closely approximates percentage-wise the unit price or item total in the County's final estimate of cost.

If both the unit price and the item total are unreadable or otherwise unclear, or are omitted, the bid may be deemed irregular. Likewise if the item total for a Lump Sum item is unreadable or otherwise unclear, or is omitted, the bid may be deemed irregular unless the project being bid has only a single item and a clear, readable total bid amount is provided.

Symbols such as commas and dollar signs will be ignored and have no mathematical significance in establishing any unit price or item total or Lump Sums. Written unit prices, item totals and Lump Sums will be interpreted according to the number of digits and, if

applicable, decimal placement. Cents symbols also have no significance in establishing any unit price or item total since all figures are assumed to be expressed in dollars and/or decimal fractions of a dollar.

Bids on Lump Sum items shall be item totals only; if any unit price for a Lump Sum item is included in a bid and it differs from the item total, the items total shall prevail.

The foregoing provisions for the resolution of specific irregularities cannot be so comprehensive as to cover every omission, inconsistency, error or other irregularity which may occur in a bid. Any situation not specifically provided for will be determined in the discretion of the County, and that discretion will be exercised in the manner deemed by the County to best protect the public interest in the prompt and economical completion of the work. The decision of the County respecting the amount of a bid, or the existence or treatment of an irregularity in a bid, including determination of non-responsiveness, shall be final.

The County hereby reserves the right to reject any and all bids, to waive any irregularity, and to award the Contract to other than the lowest bidder.

15. Like Bid Items

The Bidder is advised that the items of work may be grouped into bid schedules, and that certain bid items may be listed in more than one bid schedule, and listed with different bid item numbers, and the following will apply thereto:

The Bidder is directed to submit the same bid amount for all bid items that are listed with the same item code and item description. Said bid items are referred to herein as "Like Bid Items".

"Like Bid Items" will be considered a single bid item for purposes of calculating increased and decreased quantities, and as otherwise applicable in Section 4-1.03, "Changes" of the Standard Specifications.

The following are not subject to this bidding requirement:

1. Bid items with the same item code but different item descriptions.
2. Bid items that are measured as "Lump Sum" or "Force Account".
3. Alternate Bid Schedules.

In the event that a Bidder submits different unit bid amounts for "Like Bid Items", as described above, the bid will be corrected by applying the lowest of the unit bid amounts to all the respective "Like Bid Items".

16. Contract Documents

The complete Contract Documents are identified in the Contract. Potential Bidders are cautioned that the successful Bidder incurs duties and obligations under all of the Contract Documents and that they should not merely skim and hastily review the Plans and Specifications in making their bid.

17. Submission of Bidder's Bid

A Bidder's Bid must be submitted in a sealed opaque envelope that clearly identifies the Bidder's name and the project name. Bids must be received before the scheduled date and time at the location set forth in the Notice to Bidders and may be withdrawn only as stated in the Bid. Bids must be completed in ink.

18. Qualifications of Bidders

No award will be made to any Bidder who cannot give satisfactory assurance to the Board of Supervisors as to his own ability to carry out the Contract, both from his financial standing and by reason of his previous experience as a Contractor on work of the nature contemplated in the Contract. The Bidder may be required to submit his record of work of similar nature to that proposed under these specifications and unfamiliarity with the type of work may be sufficient cause for rejection of bid.

19. Design Engineer May Not Bid On Construction Contract:

No engineering or architectural firm which has provided design services for a project shall be eligible to bid on the Contract to construct the project. The firms ineligible to bid include: the prime Contractor/Consultant for design, subcontractors of portions of the design and affiliates of either. An affiliate is a firm which is subject to the control of the same persons, through joint ownership or otherwise.

20. Award of Contract

The Bidder's attention is directed to the provisions in Section 3, "Award and Execution of Contract" of the Standard Specifications and the Instruction to Bidders for the requirements and conditions concerning award and execution of Contract.

The award of the Contract, if it be awarded, will be to the lowest responsible bidder whose bid complies with all the requirements prescribed.

The County reserves the right to reject all bids received.

Acceptance, by the governing body of the County by resolution or minute order at a meeting regularly called and held, of a Bid constitutes an award of the Contract and the execution of the Contract is a written memorial thereof.

The County will submit the Contract Documents to the low responsive and responsible Bidder for execution prior to award utilizing the following procedures and requirements:

- A. A Bidder whose Bid is accepted must execute the formal construction Contract with the County, similar to the form attached hereto as a sample, and must return said Contract, together with approved Performance Bond and Payment Bond and with complete evidence of insurance as required elsewhere herein, including executed additional insured endorsements and waivers of subrogation, within ten (10) business days from the date of the Notice of Acceptance of Bid and Intent to Award as issued by the Transportation Department. All submittals must meet the requirements of the bid documents. Corrections, if required, must be made and the revised documents must be resubmitted within two (2) business days of Contractor's receipt of review comments.
- B. The bonds and insurance documentation must be submitted in accordance with the Contract Document requirements prior to submission to the County of Riverside Board of Supervisors for award by the Transportation Department and prior to the performance of any work under the Contract.
- C. If a Bidder to whom a Notice of Acceptance of Bid and Intent to Award has been issued, fails or refuses to sign a construction Contract, or to furnish the bonds or insurance certificates and endorsements as required within the prescribed period of time as described above, the County may, at its sole discretion, rescind the Notice of Acceptance, and the bid guarantee submitted by that Bidder will become the property of the County as prescribed in the bid documents and as allowed by law.
- D. If it is in the best interest of the County, the County reserves the right to award the Contract prior to execution by the Contractor. Thereafter, County will mail or deliver the County signed Contract to the awarded Contractor for execution and return.

Bid Protest

Any Bidder submitting a bid to County may file a protest of the County's proposed Award of the Contract provided that each and all of the following are complied with:

1. The bid protest is in writing.
2. The bid protest is filed with and received by County of Riverside Transportation and Land Management Agency at the following address:

County of Riverside
Transportation Department
Attention: Contracts/Bidding Unit
3525 14th Street
Riverside, CA 92501

Facsimile: (951) 955-3164
Electronic mail: jrjimenez@rctlma.org

3. The bid protest is filed with and received not more than five (5) calendar days following the date of issuance of the Notice of Intent to Award. Notice of Intent to Award letter is posted on the County of Riverside Transportation Department website along with the project bid summary. URL for this webpage is http://www.rctlma.org/trans/con_bid_summaries.html. Failure to timely file and serve the bid protest as aforesated shall constitute grounds for the County's denial of the bid protest without consideration of the grounds stated therein.
4. The written bid protest sets forth, in detail, all grounds for the bid protest, including without limitation all facts, supporting documentation, legal authorities and argument in support of the grounds for the bid protest. Any grounds not set forth in the bid protest shall be deemed waived. All factual contentions must be supported by competent, admissible and credible evidence. Any bid protest not conforming to the foregoing shall be rejected as invalid.
5. Provided that a bid protest is filed in conformity with the foregoing, the Director of TLMA, or such individual(s) as may be designated by the Director in his discretion, shall review and evaluate the basis of the bid protest, and shall provide a written decision to the Bidder submitting the bid protest, either concurring with or denying the bid protest. The written decision of the Director or his designee shall be final, unless overturned by the Board of Supervisors.

21. Payment and Performance Bonds

The County requires a 100% Payment Bond and 100% Performance Bond from the successful Bidder. All bonds must be on County's forms contained in the Bid Book.

The bonds must be underwritten by a Surety Company, which is admitted to transact the business of insurance in the State of California, and which carries a rating in the current issue of Best's Insurance Guide of "A" or better with a financial size of at least "VIII". The bond forms included in the Bid Book must be used. All signatures on the bonds must be notarized. Bonds must be provided with an executed Power of Attorney issued by the Surety.

22. Return of Bid Guarantee

Bid bonds will not be returned unless specifically requested by the Bidder in writing. Any submitted negotiable securities of unsuccessful Bidders will be returned by mail within 30 days of the award of a contract to the successful Bidder. Any submitted negotiable security of the successful Bidder will be returned by mail within 30 calendar days of acceptable receipt of executed Contract, certificate of insurance, Performance Bond and Payment Bond.

23. Submission of Insurance Certificate and Endorsements

Attention is directed General Conditions Section 4 "Insurance and Hold Harmless."

Within ten (10) working days of the date of the Notice of Acceptance of Bid and Intent to Award issued by the County, the successful Contractor must submit a certificate of insurance, including required endorsements, which provides evidence that the bidding Contractor has insurance coverage that meets the requirements of General Conditions "Insurance and Hold Harmless" section. Failure to have complete insurance coverage in place and to provide all required certificates and endorsements within the specified ten (10) business day period will be grounds to declare the Bidder as non-compliant with the bid documents, rescinding the Notice of Acceptance, making a claim against the bid bond, and awarding to the second low Bidder, at the sole discretion of the County.

Bid

Date: _____

To: County of Riverside, hereafter called "County";

Bidder: _____
(hereafter called "Contractor")

The undersigned, Contractor, having carefully examined the site and the Contract Documents for the construction of Avenida Florencita Sidewalk Project, Between Camino Aventura and Camino Campanero, Project No. C3-0050, In the Southeast Desert Hot Springs Community hereby proposes to construct the work in accordance with the Contract Documents, including Addenda Number(s) _____ (Fill in addenda numbers if addenda have been issued.) for the amount stated in this Bid.

By submitting this Bid, Contractor agrees with County:

1. That unless withdrawn in person by Contractor or some person authorized in writing by Contractor (not by telephone or facsimile) before the time specified in the Notice Inviting Bids for the public opening of bids, this Bid constitutes an irrevocable offer for 90 calendar days after that date.
2. County has the right to reject any or all Bids and to waive any irregularities or informalities contained in a Bid.
3. To execute the Contract and deliver the Performance Bond, Payment Bond and Insurance Certificate with endorsements, that comply with the requirements set forth in the Instruction to Bidders and General Conditions, within ten (10) business days of the date of the Notice of Acceptance of Bid and Intent to Award as issued by the County.
4. That the contract shall be awarded upon a resolution or minute order to that effect duly adopted by the governing body of County; and that execution of the Contract shall constitute a written memorial thereof.
5. To submit to the County such information as County may require determining whether a particular Bid is the lowest responsible bid submitted.
6. That the accompanying Bid Bond, certified check or cashier's check is in an amount not less than 10% of the total bid submitted and constitutes a guarantee that if awarded the contract, Contractor will execute the Contract and deliver the required bonds within ten (10) business days after notice of award. If Contractor fails to execute and deliver said documents, the bond or check is to be charged with the costs of the resultant damages to the County, including but not limited to: publication costs, the difference in money between the amount bid and the amount in excess of the bid which it costs County to do or cause to be done for the work involved, lease and rental costs, additional salaries and overhead, increased interest and costs of funding the project, attorney expense, additional engineering and architectural expense and cost of maintaining or constructing alternate facilities occasioned by the failure to execute and deliver said documents.
7. By signing this Bid the Contractor certifies that the representations made therein are made under penalty of perjury.

**Avenida Florencita
Sidewalk Project
Between Camino Aventura and Camino Campanero
Project No. C3-0050**

In the Southeast Desert Hot Springs Community

PROPOSAL

ITEM No.	ITEM CODE	ITEM	UNIT	ESTIMATED QUANTITY	ITEM PRICE (IN FIGURES)	TOTAL (IN FIGURES)
BASE BID						
1	066102	DUST ABATEMENT	LS	1		
2	074020	WATER POLLUTION CONTROL	LS	1		
3	120100	TRAFFIC CONTROL SYSTEM	LS	1		
4	160101	CLEARING AND GRUBBING	LS	1		
5	170101	DEVELOP WATER SUPPLY	LS	1		
6	152380	RELOCATE CHAIN LINK FENCE	LF	160		
7	000003	ADJUST EXISTING ROLLING/SLIDING GATE	EA	2		
8	000003	REMOVE AND REPLACE MAILBOX NEW	EA	21		
9	017307	MINOR CONCRETE (TYPE "C" CURB) (CRS 202)	LF	40		
10	000003	MINOR CONCRETE (CURB TRANSITION) (CRS 211)	LF	50		
11	017306	MINOR CONCRETE (CURB RAMP) (CRS 403)	EA	2		
12	731623	MINOR CONCRETE (CURB RAMP) [CALTRANS CASE C]	EA	1		
13	000003	CONSTRUCT PEDESTRIAN RAMP WITH HANDRAIL	EA	1		
14	017303	MINOR CONCRETE (SPANDREL) (CRS 209)	SQFT	425		
15	731521	MINOR CONCRETE (SIDEWALK)	SQFT	13,890		
16	731516	MINOR CONCRETE (DRIVEWAY)	SQFT	3,100		
17	160120	REMOVE TREE	EA	7		
18	151281	REMOVE AND SALVAGE ROADSIDE SIGNS	EA	4		
19	566011	ROADSIDE SIGN - ONE POST	EA	5		
20	010602	MISCELLANEOUS WORK (AS DIRECTED)	FA	1	5,000.00	5,000.00
21	019901	DE-MOBILIZATION	LS	1	8,000.00	8,000.00

PROJECT TOTAL: _____ \$ _____
ITEMS 1-21 "WORDS"

Bidder Data and Signature

Name of Bidder: _____

Type of organization: _____

Person(s) authorized to sign for Bidder: _____

Note:

If Bidder or other interested person is a **Corporation**, state legal name of Corporation and also names of the president, secretary, treasurer and manager thereof.

If Bidder or other interested person is a **Co-Partnership**, state true name of firm and also names of all individual co-partners composing firm.

If Bidder or other interested person is an **Individual**, state first and last name(s) in full.

Business Street Address: _____
(Please include business address even if P.O. Box is used.)

Business City, State, Zip Code: _____

P.O. Box- Number: _____

P.O. Box- City, State, Zip Code: _____

Phone: (_____) _____

Facsimile: (_____) _____

E-mail: _____

Contractor's license number: _____

License Classification(s): _____

Expiration date: _____

Bidder Data and Signature (continued)

Accompanying this Bid is a certified check, cashier check or bid bond in an amount equal to at least ten (10) percent of the total bid for:

**Avenida Florencita
Sidewalk Project
Between Camino Aventura and Camino Campanero
Project No. C3-0050
In the Southeast Desert Hot Springs Community**

By my signature on this Bid, I certify, under penalty of perjury under the laws of the State of California, that all the information on this form is true and correct.

IN WITNESS WHERE OF Bidder/Contractor executed this Bid as of the date set forth on page B1 of this Bid.

Signature:

Name (printed):

Title:

“Contractor”

(If the Bidder is a Corporation, attach the Corporate Resolution which authorizes the signature to represent the Corporation. Certification for Authorized Signatures of Officers and Certificate of Incumbency are also acceptable and document must show that person who signs is authorized to do so for the company.)

Subcontractor List

Bidder/Contractor submits the following complete list of each Subcontractor who will perform work, labor or render service in or about the construction in an amount in excess of 1/2 of 1% of the total bid or \$10,000 whichever is greater.

Check box on right side of row if any construction item, for the listed Subcontractor, is partial work. If partial work is to be performed within a certain construction item or trade, the Bidder/Contractor shall specify the portion(s) of the work to be performed by the different subcontractors or Bidder/Contractor will be subject to provisions of Public Contract Code Section 4106.

	Subcontractor Name	License Number	Business Address (City, State)	Construction Item(s) [Item Number and Description]	Check if Partial Work
1.					<input type="checkbox"/>
2.					<input type="checkbox"/>
3.					<input type="checkbox"/>
4.					<input type="checkbox"/>
5.					<input type="checkbox"/>
6.					<input type="checkbox"/>
7.					<input type="checkbox"/>

(If applicable, check box.) Additional information for Subcontractor List is attached to this Bid. (A copy of this form may be attached with additional Subcontractor information.)

Percent of work to be performed by Subcontractors: _____ %

Note: A minimum of 50% of the work is required to be performed by the general/prime Contractor.

Non-Collusion Declaration

To be executed by bidder and submitted with bid.
(Title 23 United States Code Section 112 and Public Contract Code Section 7106)

The undersigned declares:

I am the _____ (Title) of _____ (Company),
the party making the foregoing bid.

The bid is not made in the interest of, or on behalf of, any undisclosed person, partnership, company, association, organization, or corporation. The bid is genuine and not collusive or sham. The bidder has not directly or indirectly induced or solicited any other bidder to put in a false or sham bid. The bidder has not directly or indirectly colluded, conspired, connived, or agreed with any bidder or anyone else to put in a sham bid, or that anyone shall refrain from bidding. The bidder has not in any manner, directly or indirectly, sought by agreement, communication, or conference with anyone to fix the bid price of the bidder or any other bidder, or to fix any overhead, profit, or cost element of the bid price, or of that of any other bidder.

All statements contained in the bid are true. The bidder has not, directly or indirectly, submitted his or her bid price of any breakdown thereof, or the contents thereof, or divulged information or data relative thereto, to any corporation, partnership, company, association, organization, bid depository, or to any member or agent thereof to effectuate a collusive or sham bid, and has not paid, and will not pay, any person or entity for such purpose.

Any person executing this declaration on behalf of a bidder that is a corporation, partnership, joint venture, limited liability company, limited liability partnership, or any other entity, hereby represents that he or she has full power to execute, and does execute, this declaration on behalf of the bidder.

I declare under penalty of perjury under the applicable laws that the foregoing is true and correct and that this declaration is executed on

_____ (Month) _____ (Day) of _____ (Year),

at _____ (City), _____ (State).

Signature of Declarant: _____

Printed name of Declarant: _____

Name of Bidder (Company): _____

Title or Office: _____

Note: Notarization of signature required.
 Check box if attachment is included.

Iran Contracting Act
(Public Contract Code sections 2200-2208)

Prior to bidding on, submitting a proposal or executing a contract or renewal for a County of Riverside contract for goods or services of \$1,000,000 or more, a Contractor must either:

- a) Certify it is not on the current list of persons engaged in investment activities in Iran created by the California Department of General Services ("DGS") pursuant to Public Contract Code section 2203(b) and is not a financial institution extending twenty million dollars (\$20,000,000) or more in credit to another person, for 45 days or more, if that other person will use the credit to provide goods or services in the energy sector in Iran and is identified on the current list of persons engaged in investment activities in Iran created by DGS; or
- b) Demonstrate it has been exempted from the certification requirement for that solicitation or contract pursuant to Public Contract Code section 2203(c) or (d).

To comply with this requirement, please insert your Contractor or financial institution name and Federal ID Number (if available) and complete one of the options below. Please note: California law establishes penalties for providing false certifications, including civil penalties equal to the greater of \$250,000 or twice the amount of the contract for which the false certification was made; contract termination; and three-year ineligibility to bid on contracts. (Public Contract Code section 2205.)

Option #1 – Certification

I, the official named below, certify I am duly authorized to execute this certification on behalf of the vendor/financial institution identified below, and the vendor/financial institution identified below is **not** on the current list of persons engaged in investment activities in Iran created by DGS and is not a financial institution extending twenty million dollars (\$20,000,000) or more in credit to another person/vendor, for 45 days or more, if that other person/vendor will use the credit to provide goods or services in the energy sector in Iran and is identified on the current list of persons engaged in investment activities in Iran created by DGS.

<i>Contractor Name/Financial Institution (Printed)</i>		<i>Federal ID Number (or n/a)</i>
<i>By (Authorized Signature)</i>		
<i>Printed Name and Title of Person Signing</i>		
<i>Date Executed</i>	<i>Executed in</i>	

Option #2 – Exemption

Pursuant to Public Contract Code sections 2203(c) and (d), a public entity may permit a Contractor/financial institution engaged in investment activities in Iran, on a case-by-case basis, to be eligible for, or to bid on, submit a proposal for, or enters into or renews, a contract for goods and services.

If you have obtained an exemption from the certification requirement under the Iran Contracting Act, please fill out the information below, and attach documentation demonstrating the exemption approval.

<i>Contractor Name/Financial Institution (Printed)</i>		<i>Federal ID Number (or n/a)</i>
<i>By (Authorized Signature)</i>		
<i>Printed Name and Title of Person Signing</i>		
<i>Date Executed</i>	<i>Executed in</i>	

This page intentionally left blank

Riverside County Contract No. _____

Contract

THIS CONTRACT is entered into at Riverside, California as of the date set forth below is between County of Riverside hereafter called "County" and _____, hereafter called "Contractor".

WITNESSETH

Recitals:

1. Contractor has submitted to County his Contractor's Proposal for the construction of County Project, _____, in strict accordance with the Contract Documents identified below and County has accepted said Proposal.
2. Contractor states that he has reexamined his Contractor's Proposal and found it to be correct, has ascertained that his subcontractors are properly licensed and possess the requisite skill and forces, has reexamined the site and Contract Documents and is of the opinion that he can presently do the work in accordance with the Contract Documents for the money set forth in his Proposal to be paid as provided in the Contract Documents.

Agreement:

It is agreed by the parties as follows:

1. Contract Documents

The entire Contract consists of the following: (a) The Construction Contract, (b) The Notice Inviting Bids, (c) The Instruction to Bidders, (d) The Bid, (e) The Bid Bond, (f) The Payment Bond, (g) The Performance Bond, (h) The General Conditions, (i) The Special Provisions, (j) The Standard Specifications of the State of California Department of Transportation edition of **May 2006** as modified in other portions of the Contract Documents and as amended by the State of California Department of Transportation, (k) The Standard Plans of the Department of Transportation identified on the plans or in the Special Provisions, (l) The Plans, (m) Addenda _____, (n) The Determination of Prevailing Wage Rates for Public Work, (o) Any Change Orders issued, (p) Any additional or supplemental specifications, notice, instructions and drawings issued in accordance with the provisions of the Contract Documents. All of said Documents presently in existence are by this reference incorporated herein with like effect as if here set forth in full and upon the proper issuance of other documents they shall likewise be deemed incorporated. The Bid Bond is exonerated upon execution of this Contract and the Payment Bond and Performance Bond.

2. The Work

Contractor shall do all tasks necessary to construct the work generally described in Recital No. 1 in accordance with the Contract Documents.

3. Liquidated Damages and Time of Completion

Attention is directed to the provisions in Section 8-1.06, "Time of Completion", and in Section 8-1.07 "Liquidated Damages", of the Standard Specifications and these Special Provisions.

Standard Specification Section 8-1.03, "Beginning of Work" is modified to read as follows:

The Contractor shall begin work within fifteen (15) calendar days, or as revised in the Special Provisions, of the date stated within the written "Notice to Proceed".

The Contractor shall notify the Engineer, in writing, of the Contractor's intent to begin work at least 72 hours before work is begun. If the project has more than one (1) location of work, Contractor shall submit a separate notice for each location. The notice shall be delivered to the Transportation Department's Construction Engineer and shall specify the date the Contractor intends to start at said location.

Should the Contractor begin work in advance of receiving a written "Notice to Proceed", any work performed by the Contractor in advance of the date stated in the "Notice to Proceed" shall be considered as having been done by the Contractor at his own risk and as a volunteer and subject to the following:

- A. The Contractor shall, on commencing operations, take all precautions required for public safety and shall observe all the provisions in the Specifications and the Special Provisions.
- B. All work done according to the Contract, prior to the issuance of the "Notice to Proceed", will be considered authorized work and will be paid for as provided in the contract.
- C. The Contractor shall not be entitled to any additional compensation or an extension of time for any delay, hindrance or interference caused by or attributable to commencement of work prior to the issuance of the "Notice to Proceed".

4. Compensation

Contractor shall be paid in the manner set forth in the Contract Documents the amount of his Proposal as accepted by County, the above rates, subject to additions and deductions as provided in the Contract Documents. Said Proposal is on file in the Office of the Clerk of the Board of Supervisors of County.

**Avenida Florencita
Sidewalk Project
Between Camino Aventura and Camino Campanero
Project No. C3-0050
In the Southeast Desert Hot Springs Community**

IN WITNESS WHEREOF the parties hereto have executed this Contract as of the date set forth below.

COUNTY OF RIVERSIDE

CONTRACTOR

BY: _____

BY: _____

Chairman, Board of Supervisors

TITLE: _____

(If Corporation, affix Seal)

DATED: _____

ATTEST:

ATTEST:

Kecia Harper-Ihem, Clerk of the Board

BY: _____

TITLE: _____

Deputy

Licensed in accordance with an act providing
for the registration of Contractors,

License No. _____

Federal Employer Identification Number:

BY _____

"County"

"Corporation"
(Seal)

Performance Bond

Recitals:

1. _____ (Contractor) has entered into a Contract with COUNTY OF RIVERSIDE (County) for construction of public work known as Avenida Florencita Sidewalk Project, Between Camino Aventura and Camino Campanero, Project No. C3-0050, In the Southeast Desert Hot Springs Community.
2. _____, a _____ corporation (Surety), is the Surety under this Bond.

Agreement:

We, Contractor as Principal and Surety as Surety, jointly and severally agree, state, and are bound unto County, as obligee, as follows:

1. The amount of the obligation of this Bond is 100% of the estimated contract price for the Project of \$ _____ and inures to the benefit of County.
2. This Bond is exonerated by Contractor doing all things to be kept and performed by it in strict conformance with the Contract Documents for this project, otherwise it remains in full force and effect for the recovery of loss, damage and expense of County resulting from failure of Contractor to so act. All of said Contract Documents are incorporated herein.
3. This obligation is binding on our successors and assigns.
4. For value received, Surety stipulates and agrees that no change, time extension, prepayment to Contractor, alteration or addition to the terms and requirements of the Contract Documents or the work to be performed thereunder shall affect its obligations hereunder and waives notice as to such matters, except the total contract price cannot be increased by more than 10% without approval of Surety.

THIS BOND is executed as of _____.

By _____

By _____

By _____

Type Name _____

Title _____

Its Attorney in Fact
"Surety"

"Contractor"

(Corporate Seal)

(Corporate Seal)

NOTE: This Bond must be executed by both parties with corporate seal affixed. All signatures must be acknowledged. (Attach acknowledgements).

Payment Bond

(Public Works - Civil Code §9550 et seq.)

The makers of this Bond are _____, as Principal and Original Contractor and _____, a corporation, authorized to issue Surety Bonds in California, as Surety, and this Bond is issued in conjunction with that certain public works contract to be executed between Principal and COUNTY OF RIVERSIDE a public entity, as Owner, for \$ _____, the total amount payable. The amount of this bond is one hundred percent (100%) of said sum. Said contract is for public work generally consisting of Avenida Florencita Sidewalk Project, Between Camino Aventura and Camino Campanero, Project No. C3-0050, In the Southeast Desert Hot Springs Community.

The beneficiaries of this Bond are as is stated in 9554 of the Civil Code and requirements and conditions of this Bond are as is set forth in 9554, 9558, 9560 and 9564 of said code. Without notice, Surety consents to extension of time for performance, change in requirements, amount of compensation, or prepayment under said contract.

Dated: _____

Original Contractor – Principal

Surety

By _____

By _____

Title _____

Its Attorney In Fact

(If corporation, affix seal)

(Corporate Seal)

(Corporate Seal)

STATE OF _____ }
COUNTY OF _____ }

ss. SURETY'S ACKNOWLEDGEMENT

On _____ before me, _____ personally appeared, _____, known to me, or proved to me on the basis of satisfactory evidence, to be the person whose name is subscribed to the within instrument and acknowledged to me that he executed the same in his authorized capacities, and that by his signature on the instrument the person, or the entity upon behalf of which the person acted, executed the instrument.

WITNESS my hand and official seal.

Signature of Notary Public

Notary Public (Seal)

NOTE: This Bond must be executed by both parties with corporate seal affixed. All signatures must be acknowledged. (Attach acknowledgements).

**General Conditions
Table of Contents**

1.	Definitions and Terms.....	GC 2
2.	Standard Specifications.....	GC 2
3.	Director of Transportation and Land Management Agency (TLMA).....	GC 3
4.	Insurance and Hold Harmless	GC 4
5.	Beginning of Work, Time of Completion, and Liquidated Damages.....	GC 9
6.	County's Right to Stop Work or Terminate the Contract	GC 9
7.	General Prevailing Wage:.....	GC 10
8.	Labor Code	GC 10
9.	Labor Nondiscrimination	GC 11
10.	Equal Employment Opportunity	GC 11
11.	Subcontracting	GC 13
12.	Monthly Progress Estimates and Payments	GC 14
13.	Deposit of Securities.....	GC 15
14.	Payment Retention.....	GC 15
15.	Payment for Extra Work (Force Account Basis)	GC 15
16.	Change Orders – Detail Drawings and Instructions.....	GC 17
17.	Final Payment	GC 18
18.	Assignment of Claims.....	GC 18
19.	Arbitrations	GC 19
20.	Claims Resolution.....	GC 19
21.	Brand or Trade Name – Substitute of Equals	GC 20
22.	Site Inspection – Effect of Other Improvements Shown and Contractor Procedure	GC 21
23.	Public Safety	GC 21
24.	Extra Work.....	GC 23
25.	Sounds Control Requirements	GC 24
26.	Use, Care and Protection of Premises.....	GC 24
27.	Obstructions	GC 25
28.	Removal of Asbestos and Hazardous Substances.....	GC 26
29.	Documents of Contractor.....	GC 26
30.	Responsibility of Contractor to Act in an Emergency	GC 26
31.	Final Inspection – Notice of Completion.....	GC 26
32.	Dust Abatement	GC 27

General Conditions

1. Definitions and Terms

Whenever in the Standard Specifications the following terms are used, they shall be understood to mean and refer to the following:

- A. "Department", "Department of Transportation", "State", and "State of California" means the County of Riverside.
- B. "Engineer", "State Highway Engineer", "Director", and "Director of Transportation" means the Director of Transportation and Land Management Agency (TLMA) for the County of Riverside, and includes his authorized representatives.
- C. "Laboratory" means the established laboratory of the County of Riverside.
- D. "Plans" means the portion of the Contract Documents consisting of all drawings prepared for the direction and characteristics of the work. A schedule of said drawings which constitutes the plans as of the execution of the Contract is set forth in the Special Provisions and are supplemented by the Standard Plans referred to in the Special Provisions.

Other terms appearing in the Standard Specifications and Contract Documents, including the Special Provisions, shall have the intent and meaning specified in Section 1, "Definition and Terms" of the Standard Specifications. The following are additional terms appearing in the Contract Documents:

- "County", "Contractor" and "Contract Documents" are identified in the Contract. "County" and "Contractor" includes their authorized representatives are treated throughout as if each were singular in number. "Contractor" includes its surety.
- "Business Day" is defined as 7:30 a.m. to 5:30 p.m. Monday through Thursday, excepting therefrom when County is closed for holidays as set forth in County Ordinance 358, Section 1, items c. through q. Some County services, including but not limited to Survey, Project Development, Environmental, Traffic Engineering, Accounting, Planning, and Permits, will not be available Fridays.
- "You" and "Your" means the Bidder and/or Contractor.

2. Standard Specifications

The Standard Specifications of the State of California Department of Transportation, edition of May 2006 hereafter called "Standard Specifications", are incorporated herein as modified in these General Conditions, the Special Provisions and the Plans.

The following subsections of the Standard Specifications are deleted:

1-1.13, 1-1.15, 1-1.18, 1-1.25, 1-1.37, 1-1.40, 2-1.01, 2-1.05, 2-1.07, 5-1.14, 7-1.165, 8-1.03, 9-1.05, 9-1.065, 9-1.10, 12-2.02.

Section 3 of the Standard Specifications is deleted.

The following deletions and additions are made from the following subsections of the Standard Specifications.

Subsection 5-1.04, add to the second paragraph at its end the following sentence: "The General Conditions govern over all of the Contract Documents except the Special Provisions, the Contract and Bonds."

Subsection 7-1.15, for "Director" read "Director of TLMA" except for last paragraph read "County of Riverside".

Subsection 7-1.16, delete references to Subsection 7-1.165.

Subsection 8-1.06, strikethrough the last paragraph.

Subsection 8-1.08, strikethrough "as provided in the State Contract Act".

3. Director of Transportation and Land Management Agency (TLMA)

All work shall be done under the supervision of the Director of TLMA who shall determine the amount, quality, acceptability and fitness of all parts of the work, and interpret the Contract Documents. No act or omission of the Director of TLMA relieves Contractor of the duty to proceed with the work in strict conformity with the Contract Documents.

Upon request, Director of TLMA shall reduce to writing any oral order, objection, requirement or determination. Whenever the Director of TLMA's approval is required, it shall be in writing only.

All communications to the County by Contractor shall be via the Director of TLMA, or such individual(s) as may be designated by the Director of TLMA in his discretion.

No work shall be performed on site other than during normal working hours without the knowledge and consent of the Director of TLMA.

When in Director of TLMA's opinion, weather or other conditions are such that attempts to perform a portion of the work will probably result in work not in accordance with the Contract Documents, he shall so advise the Contractor. When Contractor advises the Director of TLMA that he intends to proceed despite such advice, he does so at his peril. The Director of TLMA may then order Contractor, in writing which specifies the portion of the

work involved and the conditions warranting the issuance of the order, not to proceed on such portion of the work if: (1) proceeding will, in his judgment, have an adverse effect on Contractor's ability to complete the work within the stipulated time period, or (2) proceeding will, in his judgment, necessitate unusual tests and procedures to ascertain whether said portion of the work is in accordance with the Contract Documents. Contractor shall comply with such orders at its expense.

Nothing herein contained relieves Contractor from the duty to make independent determinations as to weather and other conditions affecting the proper completion of the work.

Failure for any reason of Director of TLMA to advise Contractor as to such matters, or to issue an order as above provided, does not relieve the Contractor from the duty to accomplish the work in accordance with the Contract Documents.

As stated elsewhere, amounts shown in the Bid and Contract as to quantities are merely estimates only. From time to time Director of TLMA shall direct Contractor as to the prosecution of the work in such a manner as to increase or decrease such estimates as to the work actually to be done. Contractor shall comply with such instructions and shall be paid only for work actually done based on the unit price set out in the Contract.

4. Insurance and Hold Harmless

In lieu of the provisions of Standard Specification Section 7-1.12 the following shall apply:

A. General:

Contractor shall submit to the County a Certificate of Insurance, signed by an authorized representative of the Contractor's insurance provider or agency, which certifies to the County that insurance coverage is provided in accordance with the requirements of this Section.

Certificate Holder information is as follows:

County of Riverside
Transportation Department
Attn: Contracts/Bidding Unit
3525 14th Street
Riverside, CA 92501

Contractor shall not commence work under the Contract until he has obtained the insurance required hereunder and satisfactory proof of said insurance has been submitted to and accepted by the County.

The County may suspend all Contractor project work activities, at the Contractor's expense, for failure to maintain insurance coverage.

B. Workers Compensation:

The Contractor shall maintain statutory Workers' Compensation Insurance (Part 1) as prescribed by the laws of the State of California. Policy shall include Employers' Liability (Part 2) including Occupational Disease with limits not less than \$1,000,000 per person per accident.

This policy shall be endorsed, and signed, to waive subrogation in favor of the County.

This policy shall also name the "County of Riverside, its Agencies, Special Districts and Departments, their respective director, officers, Board of Supervisors, elected and appointed officials, employees, agents, and representatives" as Additional Insureds.

C. Commercial General Liability:

Commercial General Liability insurance coverage includes but not limited to:

1. Premises, operations and mobile equipment liability
2. Products and completed operations liability
3. Broad form property damage, (including completed operations)
4. Explosion, collapse, and underground hazards
5. Personal and advertising injury
6. Unmodified contractual liability
7. Cross liability coverage
8. Covering claims which may arise from or out of Contractor's performance of its obligations hereunder.

Commercial General Liability insurance coverage amounts are not to be less than the following:

- \$2,000,000 each occurrence
- \$2,000,000 general aggregate
- \$2,000,000 products-completed operations aggregate

Higher limits may be required for projects with higher risk exposure, and higher limits, if required, will be included in the Special Provisions.

Where excess liability insurance is used in connection with primary liability insurance, the combination of such coverage sum must allow total limits of liability to be in amounts not less than the specified amounts.

This policy shall name the "County of Riverside, its Agencies, Special Districts and Departments, their respective director, officers, Board of Supervisors, elected and appointed officials, employees, agents, and representatives" as Additional Insureds.

For additional insured endorsement for excess liability insurance, an acceptable alternative to the policies is a letter, signed by an authorized representative of the insurance carrier, confirming in writing that the policy follows form with respect to the primary liability policy.

D. Automobile Liability:

Contractor shall maintain liability insurance for any auto, all owned, non-owned and hired vehicles so used in an amount not less than \$1,000,000 per occurrence combined single limit. If such insurance contains a general aggregate limit, it shall apply separately to the Contract or be no less than two (2) times the occurrence limit.

Policy shall name the "County of Riverside, its Agencies, Special Districts and Departments, their respective director, officers, Board of Supervisors, elected and appointed officials, employees, agents, and representatives" as Additional Insureds.

E. General Insurance Provisions:

1. **Insurer.** Any insurance carrier providing insurance coverage hereunder shall be admitted to the State of California and have an A M Best rating of not less than A: VIII (A:8) unless such requirements are waived, in writing, by the County Risk Manager. If the County's Risk Manager waives a requirement for a particular insurer such waiver is only valid for that specific insurer and only for one policy term.

Non-admitted/Surplus Line insurance carriers (carriers not licensed in the State of California) may be acceptable to the County under certain conditions. Non-admitted insurance carriers providing any form of insurance coverage must be:

- a. Domiciled or authorized to do business in the United States and/or listed as an approved insurance carrier on the California Department of Insurance's List of Approved Surplus Line Insurers (LASLI) list,
 - b. Have an AM Best rating of not less than A: VIII (A:8), and
 - c. Insurer is authorized to transact in the type of insurance provided.
2. **Self-insured retention (SIR).** The Contractor must declare its insurance self-insured retention for each coverage required herein. If any such self-insured retention exceeds \$500,000 per occurrence, each such retention shall have the prior written consent of the County Risk Manager before the commencement of operations under the Contract. Upon notification of self-insured retention unacceptable to the County, and at the election of the Country's Risk Manager, Contractor's carriers shall either:

- a. Reduce or eliminate such self-insured retention as respects the Contract with the County, or
 - b. Procure a bond which guarantees payment of losses and related investigations, claims administration, and defense costs and expenses.
3. ***Certificate, policy, endorsements and attachments.*** Contractor shall cause Contractor's insurance carrier(s) to furnish the County with:
- a. A properly executed original Certificate(s) of Insurance and certified original copies of signed endorsements effecting coverage as required herein, and
 - b. All endorsements must include a reference to the policy by type of insurance and policy number that it is endorsing, and
 - c. If requested to do so by the County Risk Manager, provide original certified copies of policies including all endorsements and all attachments thereto, showing such insurance is in full force and effect.

Further, said Certificate(s) and policies of insurance shall contain the covenant of the insurance carrier(s) that thirty (30) days written notice shall be given to the County prior to any material modification, cancellation, expiration or reduction in coverage of such insurance (For nonpayment of premium cause for cancellation, a written notice of at least ten (10) days is allowed per California Insurance Code §662(a)). In the event of a material modification, cancellation, expiration, or reduction in coverage, the Contract shall terminate forthwith, unless the County receives, prior to such effective date, another properly executed original Certificate of Insurance and original copies of endorsements or certified original policies, including all endorsements and attachments thereto evidencing coverage's set forth herein and the insurance required herein is in full force and effect.

Contractor shall not commence operations until the County has been furnished original Certificate (s) of Insurance and certified original copies of endorsements and if requested, certified original policies of insurance including all endorsements and any and all other attachments as required in this Section. An individual authorized by the insurance carrier to do so on its behalf shall sign the original endorsements for each policy and the Certificate of Insurance.

4. ***Primary insurance.*** It is understood and agreed to by the parties hereto that the Contractor's insurance shall be construed as primary insurance, and the County's insurance and/or deductibles and/or self-insured retention's or self-insured programs shall not be construed as contributory.
5. ***Subcontractor(s).*** Contractor shall pass down the insurance obligations contained herein to all tiers of subcontractors working under the Contract.

6. **Self-insurance.** The insurance requirements contained in the Contract may be met with a program(s) of self-insurance acceptable to the County.
7. **Claim notification.** Contractor agrees to notify County of any claim by a third party or any incident or event that may give rise to a claim arising from the performance of the Contract.
8. **Certificate Holder.** Certificate address information for this project is as follows:

County of Riverside
Transportation Department
Attn: Contracts/Bidding Unit
3525 14th Street
Riverside, CA 92501

F. Hold Harmless/Indemnification:

Contractor shall indemnify and hold harmless the County of Riverside, its Agencies, Districts, Special Districts and Departments, their respective directors, officers, Board of Supervisors, elected and appointed officials, employees, agents and representatives (individually and collectively hereinafter referred to as Indemnitees) from any liability whatsoever, based or asserted upon any services of Contractor, its officers, employees, subcontractors, agents or representatives arising out of or in any way relating to the Contract, including but not limited to property damage, bodily injury, or death or any other element of any kind or nature whatsoever arising from the performance of Contractor, its officers, employees, subcontractors, agents or representatives Indemnitors from the Contract. Contractor shall defend, at its sole expense, all costs and fees including, but not limited, to attorney fees, cost of investigation, defense and settlements or awards, the Indemnitees in any claim or action based upon such alleged acts or omissions.

With respect to any action or claim subject to indemnification herein by Contractor, Contractor shall, at their sole cost, have the right to use counsel of their own choice and shall have the right to adjust, settle, or compromise any such action or claim without the prior consent of County; provided, however, that any such adjustment, settlement or compromise in no manner whatsoever limits or circumscribes Contractor's indemnification to Indemnitees as set forth herein.

Contractor's obligation hereunder shall be satisfied when Contractor has provided to County the appropriate form of dismissal relieving County from any liability for the action or claim involved.

The specified insurance limits required in the Contract shall in no way limit or circumscribe Contractor's obligations to indemnify and hold harmless the Indemnitees herein from third party claims.

In the event there is conflict between this clause and California Civil Code §2782, this clause shall be interpreted to comply with Civil Code 2782. Such interpretation shall not relieve the Contractor from indemnifying the Indemnitees to the fullest extent allowed by law.

5. Beginning of Work, Time of Completion, and Liquidated Damages

Attention is directed to Instruction to Bidders Section 12, "Hours of Work."

Attention is directed to the Contract item 3, "Liquidated Damages and Time of Completion".

Attention is directed to the Special Provision Section "Liquidated Damages".

6. County's Right to Stop Work or Terminate the Contract

(1) Contractor shall be adjudged bankrupt or make an assignment for the benefit of creditors, or (2) a receiver or liquidator is appointed for Contractor or any of his property, or (3) Contractor shall refuse or fail after Notice of Warning from County by Director of TLMA to supply sufficient properly skilled workmen or suitable materials, or (4) Contractor fails to prosecute the work with such diligence as will insure its completion within the stipulated time period, or (5) Contractor shall fail to make payments to persons supplying labor or materials for the work, or (6) Contractor does not comply with applicable law or instructions of Director of TLMA, or (7) Contractor is otherwise guilty of a substantial violation of any provision of the Contract Documents, then County without prejudice to such other and further right, remedy or relief it may be entitled to, may by ten (10) days notice to Contractor, terminate the employment of Contractor and his right to proceed, either as to the entire work, or at County's option, as to any portion thereof as to which delay shall have occurred or breach or miscompliance relates, and may thereupon take possession of the affected work and complete the work by contract or otherwise, as County deems expedient. In such case, Contractor shall not be entitled to receive any further payment until the work is finished. If the unpaid balance shall exceed the expense of completion, and other damage, expense or loss of County occasioned by Contractor's failure to properly perform, such excess shall be paid by Contractor. If such expense and damage exceeds the unpaid balance, Contractor is liable to County for the excess. If County elects to proceed under this Section, it may take possession of and utilize in completing the work such materials, supplies, plant and equipment on site which may be necessary or convenient for the purpose of completing the work, County is expressly granted the right - acting via Director of TLMA, an Engineer or otherwise - to operate equipment and machinery on site for the purpose of determining whether it has a basis for proceeding under this Section.

If the construction of the project herein is damaged, which damage is determined to have been proximately caused by an act of God, in excess of 5% of the contract amount (Public Contract Code §7105(a)), provided that the work damaged is built in accordance with

applicable building standards and the plans and specifications, then the Owner, upon certification by the Engineer, may, without prejudice to any other right of remedy, terminate the contract.

Decision by County not to proceed under this Section does not constitute a waiver by County of any right it might from time to time have against Contractor under the Contract Documents.

7. General Prevailing Wage:

Attention is directed to General Conditions Section 8, "Labor Code".

Attention is also directed to Section 7-1.01A(2), "Prevailing Wage" of the Standard Specifications.

Pursuant to §1773 of the Labor Code, the general prevailing wage rates, including the per diem wages applicable to the work, and for holiday and overtime work, including employer payments for health and welfare, pension, vacation, and similar purposes, in the county in which the work is to be done have been determined by the Director of the California Department of Industrial Relations (DIR). These wages are set forth in the General Prevailing Wage Rates for this project and are available from the DIR's web site at: <http://www.dir.ca.gov>

General prevailing wage determinations are on file at Transportation Department Washington Street Yard's Contraction/Inspection office and are available to any interested party upon written request.

General prevailing wage determinations are also made by the DIR Pursuant to California Labor Code Part 7, Chapter 1, Article 2, Sections 1770, 1773, and 1773.1 may also be obtained at the following URL:

www.dir.ca.gov/DLSR/PWD/index.htm

The Contractor must post a copy of the determination of the DIR prevailing rate of per diem wages at each job site.

8. Labor Code

Reference is made to Chapter 1, Part 7, Division 2 of the California Labor Code (commencing with §1720). By this reference said Chapter 1 is incorporated herein with like effect as if it were here set forth in full. The parties recognize that said Chapter 1 deals, among other things with discrimination, penalties and forfeitures, their disposition and enforcement, wages, working hours, and securing worker's compensation insurance and directly affect the method of prosecution of the work by Contractor and subject it under

certain conditions to penalties and forfeitures. Execution of the Contract by the parties constitutes their agreement to abide by said Chapter 1, their stipulation as to all matters which they are required to stipulate as to by the provisions of said Chapter 1, constitutes Contractor's certification that he is aware of the provisions of said Chapter 1 and will comply with them and further constitutes Contractor's certification as follows: "I am aware of the provisions of §3700 of the California Labor Code which require every employer to be insured against liability for worker's compensation or to undertake self-insurance in accordance with the provisions of that Code, and I will comply with such provisions before commencing the performance of the work of this contract." Contractor and his subcontractors shall comply with the provisions of SS 1777.5 of the Labor Code regarding apprentices.

Contractor shall post at each job site during the course of the work a copy of County's "Determination of Prevailing Wage Rates", copies of said Determination are available at Transportation Department Washington Street Yard's Construction/Inspection office for this purpose.

9. Labor Nondiscrimination

Contractor's attention is called to the "Nondiscrimination Clause", set forth in Section 7-1.01A(4), "Labor Nondiscrimination," of the Standard Specifications, which is applicable to all nonexempt state contracts and subcontracts, and to the "Standard California Nondiscrimination Construction Contract Specifications" set forth therein. The Specifications are applicable to all nonexempt state construction contracts and subcontracts of \$5,000 or more.

10. Equal Employment Opportunity

A. General

Contractor shall not discriminate in its recruiting, hiring, promotion, demotion or termination practices on the basis of race, religious creed, color, national origin, ancestry, sex, age or physical handicap in the performance of this Contract shall comply with the provisions of the California Fair Employment Practice Act (commencing with SS 1410 of the Labor Code), the Federal Civil Rights Act of 1964 (P.L. 88-352) and all amendments thereto, Executive Order No. 11246 (30 Federal Register 12319), as amended, and all administrative rules and regulations issued pursuant to said Acts and Order. See particularly 41 Code of Federal Regulation (CFR) Chapter 60.

Contractor shall require each of its subcontractors to comply with the preceding paragraph and shall include in each subcontract language similar to the preceding paragraph.

Contractor shall permit access to its records of employment, employment advertisement, application forms and other pertinent data and records by Owner and any State or Federal agency having jurisdiction for the purpose of investigation to ascertain compliance with this Section.

Owner may assign an affirmative action representative to monitor Contractor and its subcontractor(s) conduct required by this Section, including the right of entry to the construction site for the purpose of obtaining information from persons performing work on the project providing such inspection does not interfere with the progress of the work.

Elsewhere in the Contract Documents specific requirements may be contained covering the same subject matter of this Section. If so, such specific requirements prevail over this Section in case of conflict.

B. Transactions of \$10,000 or Under

Contracts and subcontracts not exceeding \$10,000 are exempt from the requirements of this Section. No Contractor or subcontractor shall procure supplies and/or services in less than usual quantities to avoid applicability of this Section. With respect to contracts and subcontracts for indefinite quantities, this Section applies unless the amount required in any one year under such contract will reasonably be expected not to exceed \$10,000.

C. Transactions in Excess of \$10,000, but Less Than \$50,000

At Owner's request, Contractor shall certify that it has in effect an affirmative action plan and agrees to comply with all State and Federal laws and regulations regarding Fair Employment Practices. Contractor shall maintain a written copy of its affirmative action plan and furnish Owner a copy of the plan upon request. Owner may require Contractor to complete an Affirmative Action Compliance Report, on a form furnished by Owner, setting forth definite goals during the term of the Contract.

D. Transactions of \$50,000 or More

If Contractor has fifty or more employees and a Contract for \$50,000 or more, it shall develop and submit to Owner, within thirty days after award, a written affirmative action compliance program providing in detail specific steps to guarantee equal employment opportunity. Contractor shall include in its affirmative action program a table of job classifications, which table shall include but need not be limited to job titles, duties, and rates of pay.

Contractor shall in each subcontract let to do a portion of the work covered hereunder, where the subcontractor involved has fifty or more employees and the subcontract is for \$50,000 or more, impose in the subcontract the above requirements.

For the purpose of determining the number of employees, the average of the Contractor's or its subcontractor's employees for the twelve month period immediately prior to award,

or the total number of employees the Contractor or its subcontractor will have when performing this contract, whichever is higher, shall be used.

E. Federal Assisted Construction

If this project is a Federally assisted construction project, then the contract provisions contained in 41 CFR SS 60-1.04 (b) are incorporated herein and the Contractor shall likewise incorporate said provisions in each subcontract entered by Contractor to perform the work. Federally assisted construction is identified as such in the Notice to Bidders.

11. Subcontracting

Attention is directed to:

- Standard Specification Section 2-1.054, "Required Listing of Proposed Subcontractors",
- Standard Specification Section 8-1.01, "Subcontracting", and
- Instruction to Bidders Section 11, "Subletting, Subcontracting, and Subcontractor List".

Contractor responsibility

No subcontract releases the Contractor from the contract or relieves the Contractor of their responsibility for a subcontractor's work.

Violations and remedies

If the Contractor violates Public Contract Code § 4100 et seq., the County may exercise the remedies provided under Public Contract Code § 4110. The County may refer the violation to the Contractors State License Board as provided under Public Contract Code § 4111.

50% Minimum work performance

The Contractor shall perform work equaling at least 50 percent of the value of the original total bid with the Contractor's own employees and equipment, owned or rented, with or without operators.

Subcontractor compliance

Each subcontractor must comply with the contract.

Active license

Each subcontractor must have an active and valid State contractor's license with a classification appropriate for the work to be performed (Business & Professional Code, § 7000 et seq.).

Submittal of subcontracts

Contractor must submit copies of subcontracts upon request by the Engineer.

Submittal of subcontractor request form

Before subcontracted work starts, Contractor must submit a Subcontracting Request form (Caltrans LAPM, Exhibit 16-B).

Debarred contractors

The County will not award a contract to a debarred Contractor. Contractor must not use a debarred subcontractor. Pursuant to the provisions in §1777.1 of the Labor Code, the Labor Commissioner publishes and distributes a current list of contractors ineligible to perform work on a public works project. This list of debarred contractors is available from the Department of Industrial Relations web address at:

<http://www.dir.ca.gov/dlse/debar.html>

Termination of unsatisfactory subcontractors

Upon request by the Engineer, Contractor must immediately remove and not again use a subcontractor who fails to prosecute the work satisfactorily (Public Contract Code §4107(a)(7)).

Substitutions

Subcontractor substitutions will be processed as required by Public Contract Code § 4107 et seq.

12. Monthly Progress Estimates and Payments

Attention is directed to Section 9-1.06, "Partial Payments" and 9-1.07, "Payment After Acceptance" of the Standard Specifications and these Special Provisions.

For the purpose of timely payment, the "receipt of payment request" date, as described in Public Contract Code 20104.50 and as referred to herein, shall be considered to be the fifth working day following the 25th day of each month.

Within five (5) working days of the 25th day of each month the County shall:

- A. Calculate and prepare the certificate ("progress pay estimate") stating the value of the work completed for the billing month, for the purpose of determining the proper progress payment amount.
- B. If a progress pay estimate has been prepared by the County but has been contested by the Contractor as of the "receipt of payment request" date, as defined above, the County shall submit to the Contractor a document setting forth in writing a description of the dispute pertaining to the progress billing, and the County's reason for its position. Said document shall be submitted to the Contractor as soon as practicable, but not later than seven (7) calendar days after the "receipt of payment request" date.

Any progress pay estimate which is undisputed and remains unpaid for thirty (30) calendar days, after the "receipt of payment request date" shall accrue interest to the Contractor equivalent to the legal rate set forth in subdivision (a) of §685.010 of the California Code of Civil Procedure. The number of days available to the County to make a payment without incurring interest pursuant to this Section shall be reduced by the number of days by which the County exceeds the seven-day submittal requirement set forth in the paragraph above.

Pursuant to Public Contract Code §20104.50, subsection (e), the progress payment date is the date that funds are encumbered and the payment warrant is issued.

The partial payments made as the work progresses will be payment on account on work performed as of the 25th of the month and shall in no way be considered as an acceptance of any part of the work or material of the contract, nor shall they in any way govern the final estimate.

No estimate or payment shall be made when, in the judgment of the Director of TLMA, the total value of the work done since the previous estimate amounts to less than \$300.

13. Deposit of Securities

In accordance with Public Contract Code §22300 and other applicable law, the Contractor may substitute securities for any moneys withheld to ensure performance under the contract.

14. Payment Retention

Director of TLMA, once each month, after said work is commenced and until after the completion and acceptance thereof, shall make and deliver to Contractor duplicate certificates stating the value of work then completed according to the contract, estimated according to the standard of the unit contract price, and thereupon Contractor shall be paid an amount sufficient with all previous payments to make the aggregate ninety five percent (95%) of the amount earned as certified. Maximum value of progress payment retention, as set forth in Section 9-1.06 of the Standard Specifications and any other referenced text, shall be five (5%).

15. Payment for Extra Work (Force Account Basis)

Extra work to be paid for on a force account basis as directed by the Engineer will be paid for as set forth in Section 9-1.03 "Force Account Payment" of the Standard Specifications. The labor surcharge, equipment rental rates, and the right of way delay factors for each classification of equipment are listed in the Department of Transportation publication entitled "Labor Surcharge and Equipment Rental Rates". A copy of which is on file at the Office of the Director of TLMA and is hereby incorporated herein in its entirety.

The fourth paragraph in Section 9-1.03A, "Work Performed by Contractor" of the Standard Specifications is amended to read:

When extra work to be paid for on a force account basis is performed by a subcontractor, approved in accordance with the provisions in Standard Section 8-1.01, "Subcontracting" an additional markup of 5% will be added to the total cost of said extra work including all markups specified in this Section 9-1.03A. Said additional 5% markup shall reimburse the Contractor for additional administrative costs, and no other additional payment will be made by reason of performance of the extra work by a subcontractor.

The first and second paragraphs in Section 9-1.03A(3), "Equipment Rental" of the Standard Specifications is amended to read:

The Contractor will be paid for the use of equipment at the rental rates listed for such equipment in the Department of Transportation publication entitled Labor Surcharge and Equipment Rental Rates, which is in effect on the date upon which the work is accomplished and which is a part of the contract, regardless of ownership and rental or other agreement, if such may exist, for use of such equipment entered into by the Contractor, except that for those pieces of equipment with a rental rate of \$10.00 per hour or less as listed in the Labor Surcharge and Equipment Rental Rates publication and which are rented from a local equipment agency, other than Contractor owned, the Contractor will be paid at the hourly rate shown on the rental agency invoice or agreement for the time used on force account work as provided in Section 9-1.03A(3a), "Equipment on the Work." If a minimum equipment rental amount is required by the local equipment rental agency, the actual amount charged will be paid to the Contractor.

If it is deemed necessary by the Engineer to use equipment not listed in said publication, a suitable rental rate for such equipment will be established by the Engineer. The Contractor may furnish any cost data which might assist the Engineer in the establishment of such rental rate. If the rental rate established by the Engineer is \$10.00 per hour or less, the provisions above concerning rental of equipment from a local equipment agency shall apply.

The seventh paragraph in said Section 9-1.03A(3) is amended to read:

Individual pieces of equipment or tools not listed in said publication and having a replacement value of \$500 or less, whether or not consumed by use, shall be considered to be small tools and no payment will be made therefor.

Section 9-1.03A(3), "Equipment Rental" of the Standard Specifications is amended by adding Section 9-1.03A(3d), "Dump Truck Rental" as follows:

The provisions of Section 9-1.03A(3c), "Owner-Operated Equipment" shall not apply to dump truck rentals.

9-1.03A(3d) Dump Truck Rental - Dump truck rental shall conform to the provisions of Sections 9-1.03A(3), "Equipment Rental", 9-1.03A(3a), "Equipment on the Work" and 9-1.03A(3b), "Equipment not on the Work" except as follows:

Fully maintained and operated rental dump trucks used in the performance of extra work paid for on a force account basis will be paid for at the same hourly rate paid by the Contractor for use of fully maintained and operated rental dump trucks in performing contract item work.

In the absence of contract item work requiring dump truck rental, the Engineer will establish an hourly rental rate to be paid. The Contractor shall provide the Engineer with complete information on the hourly rental rates available for rental of fully maintained and operated dump trucks.

The provisions in Section 9-1.03A(1), "Labor" shall not apply to operators of rented dump trucks.

The rental rates listed for dump trucks in the Department of Transportation publication entitled Labor Surcharge And Equipment Rental Rates shall not apply.

To the total of the rental costs for fully maintained and operated dump trucks there will be added a markup of 15%. No other markups will be made by reason of performance of the work by a subcontractor or for labor.

16. Change Orders – Detail Drawings and Instructions

Reference is made to 4-1.03 and 4-1.03A of the Standard Specifications regarding change orders. Wherever in these subsections the word "Engineer" appears, replace with "County".

Each approved change order shall be considered as an amendment to the Contract Documents and will not be considered approved until executed by the Board of Supervisors, except when Director of TLMA can approve certain change orders, without the necessity of approval by the Board, as provided in a Resolution of the Board adopted January 11, 2011, Resolution 2011-015.

The above does not limit the ability of Director of TLMA to issue further detail drawings, explanations, and instructions which are customarily given by an Engineer during the course of similar work. Director of TLMA will furnish Contractor, in reasonable promptness, with further detailed explanations, instructions and drawings as may be necessary for the proper execution of the work, and Contractor shall conform to same provided they are consistent with the intent of the Contract Documents. In giving such additional instructions, explanations and drawings Director of TLMA has authority to make minor changes in the work which do not involve extra cost and are not inconsistent with the Contract Documents.

Contractor's acting on such instructions, explanations and drawings of Director of TLMA means that Contractor agrees that such explanations, instructions and drawings are within the scope of the work in accordance with the intent of the Contract Documents and do not constitute a basis for modification of the Contract Documents as to price or time.

17. Final Payment

Within thirty (30) days after the completion of the work and its acceptance by the Board of Supervisors, Director of TLMA will make a proposed final estimate in writing of the quantities of work done under the contract and the value of such work and will submit such estimate to Contractor. Within thirty (30) days thereafter Contractor shall submit to Director of TLMA his written approval of said proposed final estimate or a written statement of all claims which he has for additional compensation claimed to be due under the contract.

On Contractor's approval or if he files no claims within said period of thirty (30) days, Director of TLMA will issue a final written estimate as submitted to Contractor and County shall pay the entire sum so found to be due after deducting there from all previous payments and all amounts to be kept and all amounts to be retained under the provisions of the contract.

If Contractor files claim(s) within said period of thirty (30) days, Director of TLMA will issue as a semi-final estimate the proposed estimate submitted to Contractor and the County will within thirty (30) days pay the sum found due thereon after deducting all prior payments and all amounts to be kept and retained under the provisions of the contract, Director of TLMA shall then consider and investigate Contractor's claims and shall make such revisions in the said estimate as he may find to be due, and shall then make and issue his final written estimate. County will pay the amount so found due after deducting all previous payments and amount to be retained under the contract.

All prior or partial estimates and payments shall be subjected to correction in the final estimate and payment.

The final estimate shall be conclusive and binding against both parties to the contract on all questions relating to the performance of the contract and the amount of work done there under and compensation therefore, except in the case of gross error. Acceptance of final payment constitutes a release of County by Contractor of all claims relating to the work.

18. Assignment of Claims

In submitting a bid on this public works project, or any subcontractor agreeing to supply goods, services, or materials, and entering a contract pursuant thereto, the Contractor and/or subcontractor do offer and agree to assign to the Owner all rights, title, and interest in and to all causes of action it may have under Section 4 of the Clayton Act (15 U.S.C. Section 15) or under the Cartwright Act (Chapter 2 (commencing with §16700) of Part 2 of Division 7 of the Business and Professions Code), arising from purchases of goods, services, or materials

pursuant to the public works contract or the subcontract. This assignment shall be made and become effective at the time the awarding body tenders final payment to the Contractor, without further acknowledgement by the parties.

19. Arbitrations

Section 9-1.10, "Arbitration" of the Standard Specifications is deleted.

20. Claims Resolution

In accordance with Public Contract Code §20104 through §20104.8 and other applicable law, public works claims of \$375,000 or less, which arise between the Contractor and the Owner shall be resolved following the statutory procedure, unless the Owner has elected to resolve the dispute pursuant to Public Contract Code SS 10240 et seq.

A. All claims shall be submitted in writing and accompanied by substantiating documentation. Claims must be filed on or before the date of final payment unless other notice requirements are provided in the contract. "Claim" means a separate demand by the claimant for (1) a time extension, (2) payment of money or damages arising from work done by or on behalf of the claimant and payment of which is not otherwise expressly provided for or the claimant is not otherwise entitled, or (3) an amount the payment of which is disputed by the Owner.

1. Claims Under or equal to \$50,000

The Owner shall respond in writing to the claim within 45 days of receipt of the claim, or, the Owner may request, in writing, within 30 days of receipt of the claim, any additional documentation supporting the claim or relating to defenses of claims the Owner may have. If additional information is needed thereafter, it shall be provided upon mutual agreement of the Owner and the claimant. The Owner's written response shall be submitted 15 days after receiving the additional documentation, or within the same period of time taken by the claimant to produce the additional information, whichever is greater.

2. Claims over \$50,000 but less than or equal to \$375,000

The Owner shall respond in writing within 60 days of receipt, or, may request in writing within 30 days of receipt of the claim, any additional documents supporting the claim or relating to defenses of claims the Owner may have against the claimant. If additional information is needed thereafter, it shall be provided pursuant to mutual agreement between the Owner and the claimant. The Owner's response shall be submitted within 30 days after receipt of the further documents, or within the same period of time taken by the claimant to produce the additional information or documents, whichever is greater.

- B. If the claimant disputes the Owner's response, or if the Owner fails to respond within the statutory time period, the claimant may so notify the Owner within 15 days of the receipt of the response or the failure to respond, and demand an informal conference to meet and confer for settlement. Upon such demand, the Owner shall schedule a meeting and confer conference within 30 days.
- C. If following the meet and confer conference, the claim or any portion thereof remains in dispute, the claimant may file a claim pursuant to Government Code SS 900 et seq. and Government Code SS 910 et seq. For purposes of those provisions, the time within which a claim must be filed shall be tolled from the time the claimant submits the written claim until the time the claim is denied, including any time utilized for the meet and confer conference.
- D. If a civil action is filed to resolve any claim, the provisions of Public Contract Code SS 20104.4 shall be followed, providing for non-binding mediation and judicial arbitration.

21. Brand or Trade Name – Substitute of Equals

Reference is made to §3400 of the Public Contracts Code, which is by this reference incorporated herein with like effect as if here set forth in full.

If a potential Bidder believes he knows of an equal to a specified brand or trade name which is not mentioned in the Contract Documents, then such potential bidder may so advise Director of TLMA of such fact, giving all relevant information. If appropriate, an addendum will be issued as to the alleged equal provided that such issuance may be accomplished at least 5 business days before the time fixed for opening bids.

Unless the subject article or product is expressly designated for matching others in use in a particular public improvement either completed or in the course of completion, any bidder may, as part of its bid proposal, include a request for substitution of an item equal to any specified by brand or trade name.

Within 35 calendar days after award of the contract, Contractor may submit to Director of TLMA data substantiating such a request, and the difference, if any, in cost. Director of TLMA shall promptly investigate the request and make a recommendation to County as to equality. The governing body of County shall promptly determine whether the substitute is equal in every respect to the item specified, and approve or deny the request accordingly, and shall notify Director of TLMA of the determination made, who shall advise Contractor in writing of the decision. Unless the request is granted, substitution will not be permitted.

Nothing herein shall authorize a change in the contract price or prevent the use of change orders in the manner provided elsewhere in the Contract Documents.

22. Site Inspection – Effect of Other Improvements Shown and Contractor Procedure

Elsewhere in the Contract Documents reference may be made graphically, descriptively, or both, to the existence or possible existence of other improvements affecting the site and the prosecution of the work such as surface and subsurface utilities, drainage ditches and courses, buildings, fencing, retaining walls, roadways, curbs, trees, shrubs, and similar matters. Such matters are included to be used by Contractor to the extent he deems appropriate. However, it is expressly understood and agreed:

- A. Showing or describing such items does not mean that it is an exhaustive and complete presentation and that as to matters shown or described that they necessarily exist.
- B. All graphic presentations are schematic only unless the contrary is clearly set out elsewhere as to a particular matter.
- C. Whenever in the plans survey markers are shown, boundaries of the site are shown or contour lines are shown, Contractor may assume that such matters are shown in accordance with acceptable standards.

All improvements of the nature described above, whether elsewhere shown or described or not, shall, unless the contrary is elsewhere specifically directed, remain in place, undisturbed and suitably protected during the course of the work.

Whenever, during the course of the work, a subsurface improvement is discovered, which Contractor believes is unknown to County, he shall immediately inform Director of TLMA. Except as elsewhere provided, whenever in the course of the work it becomes apparent that the work cannot proceed without the destruction or relocation of any improvement, whether shown or described or not, Contractor shall immediately cease work affecting such improvements, notify Director of TLMA as to such circumstance, and await instructions as to how to proceed.

- D. The Contractor shall be required to cooperate fully with all utility forces or forces of other public agencies engaged in relocation, lowering, altering or otherwise rearranging any facilities interfering with the progress of work or installing any facilities thereon.

The Contractor will also be required to cooperate fully with any County or State forces working on or near the project, or requiring access to the work in the performance of their duties.

23. Public Safety

The Contractor shall provide for the safety of traffic and the public in conformance with the provisions in Section 7-1.09, "Public Safety" of the Standard Specifications and these Special Provisions.

The Contractor shall install temporary railing (Type K) between a lane open to public traffic and an excavation, obstacle or storage area when the following conditions exist:

A. Excavations

The near edge of the excavation is 12 feet or less from the edge of the lane, except:

1. Excavations covered with sheet steel or concrete covers of adequate thickness to prevent accidental entry by traffic or the public.
2. Excavations less than 1 foot deep.
3. Trenches less than 1 foot wide for irrigation pipe or electrical conduit, or excavations less than 1 foot in diameter.
4. Excavations parallel to the lane for the purpose of pavement widening or reconstruction.
5. Excavations in side slopes, where the slope is steeper than 1:4 (vertical: horizontal).
6. Excavations protected by existing barrier or railing.

B. Temporarily Unprotected Permanent Obstacles

The work includes the installation of a fixed obstacle together with a protective system, such as a sign structure together with protective railing, and the Contractor elects to install the obstacle prior to installing the protective system; or the Contractor, for the Contractor's convenience and with permission of the Engineer, removes a portion of an existing protective railing at an obstacle and does not replace such railing complete in place during the same day.

C. Storage Areas

Material or equipment is stored within 12 feet of the lane and the storage is not otherwise prohibited by the provisions of the Standard Specifications and these Special Provisions.

The approach end of temporary railing (Type K) installed in conformance with the provisions in this Special Provision section "Public Safety" and in Section 7-1.09, "Public Safety" of the Standard Specifications, shall be offset a minimum of 15 feet from the edge of the traffic lane open to public traffic. The temporary railing shall be installed on a skew toward the edge of the traffic lane of not more than 1 foot transversely to 10 feet longitudinally with respect to the edge of the traffic lane. If the 15 feet minimum offset cannot be achieved, the temporary railing shall be installed on the 10 to 1 skew to obtain the maximum available offset between the approach end of the railing and the edge of the traffic lane, and an array of temporary crash cushion modules shall be installed at the approach end of the temporary railing.

Temporary railing (Type K) shall conform to the provisions in Section 12-3.08, "Temporary Railing (Type K)" of the Standard Specifications. Temporary railing (Type K), conforming to the details shown on 1999 Standard Plan T3, may be used. Temporary railing (Type K) fabricated prior to January 1, 1993, and conforming to 1988 Standard Plan B11-30 may be used, provided the fabrication date is printed on the required Certificate of Compliance.

Temporary crash cushion modules shall conform to the provisions in "Temporary Crash Cushion Module" of these Special Provisions, if applicable.

Except for installing, maintaining and removing traffic control devices, whenever work is performed or equipment is operated in the following work areas, the Contractor shall close the adjacent traffic lane unless otherwise provided in the Standard Specifications and these Special Provisions:

Approach Speed of Public Traffic Posted Limit	Work Areas
Over 45 Miles Per Hour	Within 6 feet of a traffic lane but not on a traffic lane
35 to 45 Miles Per Hour	Within 3 feet of a traffic lane but not on a traffic lane

The lane closure provisions of this Section shall not apply if the work area is protected by permanent or temporary railing or barrier.

When traffic cones or delineators are used to delineate a temporary edge of a traffic lane, the line of cones or delineators shall be considered to be the edge of the traffic lane, however, the Contractor shall not reduce the width of an existing lane to less than 10 feet without written approval from the Engineer.

When work is not in progress on a trench or other excavation that required closure of an adjacent lane, the traffic cones or portable delineators used for the lane closure shall be placed off of and adjacent to the edge of the traveled way. The spacing of the cones or delineators shall be not more than the spacing used for the lane closure.

Suspended loads or equipment shall not be moved nor positioned over public traffic or pedestrians.

Payment

Full compensation for conforming to the provisions in this Section, Public Safety, including furnishing and installing temporary railing (Type K) and temporary crash cushion modules, shall be considered as included in the contract prices paid for the various items of work involved and no additional compensation will be allowed therefor.

24. Extra Work

Section 4-1.03D, "Extra Work" of the Standard Specifications is amended by adding the following between the second and third paragraphs:

If, in the opinion of the Engineer, such work cannot reasonably be performed concurrently with other items of work, and if a controlling item of work is delayed thereby, an adjustment of contract time of completion will be made.

25. Sounds Control Requirements

Sound control shall conform to the provisions in Section 7-1.01I, "Sound Control Requirements" of the Standard Specifications and these Special Provisions.

The noise level from the Contractor's operations, between the hours of 9:00 p.m. and 6:00 a.m., shall not exceed 86 dba at a distance of 50 feet. This requirement in no way relieves the Contractor from responsibility for complying with local ordinances regulating noise level.

Said noise level requirement shall apply to all equipment on the job or related to the job, including but not limited to trucks, transit mixers or transient equipment that may or may not be owned by the Contractor. The use of loud sound signals must be avoided in favor of light warnings except those required by safety laws for the protection of personnel.

Payment

Full compensation for conforming to the requirements of this Section, Sound Control Requirements, shall be considered as included in the prices paid for the various contract items of work involved and no additional compensation will be allowed therefor.

26. Use, Care and Protection of Premises

At his expense Contractor shall:

- A. Take every precaution against injuries to persons or damage to property.
- B. Comply with regulations governing the use of the property.
- C. Store and suitably protect his apparatus, equipment, materials and supplies in an orderly fashion on site.
- D. Place on the work only such loads as are consistent with the safety of the work.
- E. Effect all cutting, fitting, or patching of his work required to make it conform to the Plans and Specifications and interrelate with other improvements or except with the consent of Director of TLMA, cut or otherwise alter existing improvements.
- F. Protect and preserve established bench marks and monuments, make no changes in the location of such without the prior written approval of County, replace and relocate any of them which may be lost or destroyed, or which require shifting because of

necessary changes in grades or locations. All replacement and relocation work shall be accomplished only after approval of County and under the direct supervision and instruction of Director of TLMA.

- G. Before final payment remove all surplus materials, false work, temporary structures, debris, and similar matter resulting from his operations from the site and to put the site in an orderly condition.
- H. Construct, operate and maintain all passageways, guard fences, lights, barricades and other facilities required for protection by State or municipal laws and regulations and local conditions during the course of the work.
- I. Guard County's property from injury or loss.
- J. Take all reasonable precautions for dust and noise control and generally conduct operations so as not to constitute a nuisance.
- K. The Contractor shall be responsible for the protection of existing signs, fences, concrete curb and gutter and other highway facilities which may be encountered in the roadway. The replacement or repair of any facilities which the County deems necessary as a result of the Contractor's operations shall be done by the Contractor at his own expense and to the satisfaction of the County Transportation Department.

Payment

Full compensation for conforming to the requirements of this Section, Use, Care and Protection of Premises, shall be considered as included in the prices paid for the various contract items of work involved and no additional compensation will be allowed therefor.

27. Obstructions

Attention is directed to Sections 8-1.10, "Utility and Non-Highway Facilities" and 15, "Existing Highway Facilities" of the Standard Specifications and these Special Provisions.

In the event that the utility facilities mentioned within the referenced Standard Specifications and/or Special Provisions are not removed or relocated by the times specified and, if in the opinion of the Engineer, the Contractor's operations are delayed or interfered with by reason of the utility facilities not being removed or relocated by said times, the County will compensate the Contractor for such delays to the extent provided in Section 8-1.09, "Right of Way Delays" of the Standard Specifications, except as provided in Section 8-1.10, "Utility and Non-Highway Facilities" of the Standard Specifications.

28. Removal of Asbestos and Hazardous Substances

When the presence of asbestos or hazardous substances are not shown on the plans or indicated in the specifications and the Contractor encounters materials which the Contractor reasonably believes to be asbestos or a hazardous substance as defined in Section 25914.1 of the Health and Safety Code, and the asbestos or hazardous substance has not been rendered harmless, the Contractor may continue work in unaffected areas reasonably believed to be safe. The Contractor shall immediately cease work in the affected area and report the condition to the Engineer in writing.

In conformance with §25914.1 of the Health and Safety Code, removal of asbestos or hazardous substances including exploratory work to identify and determine the extent of the asbestos or hazardous substance will be performed by separate contract.

If delay of work in the area delays the current controlling operation, the delay will be considered a right of way delay and the Contractor will be compensated for the delay in conformance with the provisions in Section 8-1.09, "Right of Way Delays" of the Standard Specifications.

29. Documents of Contractor

Upon demand, Contractor shall make available to County all documents in its possession relevant to the work accomplished or to be accomplished or any demand or claim of Contractor as to County. This includes copies of documents sent by Contractor or others in its possession. Contractor shall further make available to County conformed copies of all documents submitted to the sureties who executed the Bid Bond, Performance Bond, or Payment Bond for the purpose of obtaining the sureties' signature, including any guarantee or indemnification made to such surety by others for such purpose. Contractor shall maintain in his possession all documents relative to the work for three years after Notice of Completion.

30. Responsibility of Contractor to Act in an Emergency

In case of an emergency which threatens loss or injury to property or life, Contractor shall act without previous instructions as the situation may warrant. Contractor shall notify Director of TLMA immediately thereafter. Any compensation claimed by Contractor, together with substantiating documentation shall be submitted to County via Director of TLMA.

31. Final Inspection – Notice of Completion

When the work is ready for final inspection, County shall cause the work to be inspected and subjected to such tests as seem to it to be required for the purpose of determining if the work is complete in every respect.

At a meeting of the governing body of County held within ten (10) days after final inspection, the governing body shall consider the facts developed at the inspection. If it is found that the work is apparently complete in every respect, County will accept the work and a Notice of Completion will be recorded.

As between the parties, the recordation of the Notice of Completion, unless recorded because of a cessation of labor, means only that the time for final payment and the commencement of the guarantee period commences to run.

32. Dust Abatement

Dust control shall conform to Section 10, "Dust Control", Section 7-1.01F, "Air Pollution Control", Section 17, "Watering", and Section 18, "Dust Palliative" of the Standard Specifications, Rules no. 401, 402, 403 and 403.1 of the South Coast Air Quality Management District (AQMD), Riverside County Code, Chapter 8.52, "Fugitive Dust Reduction Program For Coachella Valley" (if project location is within the Coachella Valley), all other applicable Federal and State laws, and the requirements set forth herein.

The Contractor is cautioned that failure to control fugitive dust may result in fines being levied by the South Coast Air Quality Management District to both the Contractor and the County, as Owner. The Contractor shall be fully responsible for payment of all fines pertaining to air pollution control violations, resulting from Contractor's operations related to the construction contract, which may be levied against both the Contractor and the County by the AQMD or other regulatory agencies. The Contractor's attention is directed to Section 7-1.01, "Laws to be Observed" of the Standard Specifications. The cost of all fines levied against the County will be deducted from any moneys due or which may become due to the Contractor, unless other payment arrangements are made by the Contractor.

Dust control of all of the Contractor's operations is required 24 hours per day, 7 days a week for the duration of the contract, and until the disturbed soil is permanently stabilized. The Contractor shall take every precaution to prevent emissions of fugitive dust from the project site, from locations of stockpiled materials, from unpaved driving surfaces, from haul vehicles, from inactive construction areas, and from all other operations of the Contractor. The Contractor shall plan for and carry out proper and efficient measures to prevent their operations from producing dust in amounts damaging to property or which constitute a public nuisance, or which cause harm to persons living or working in the vicinity of the work. Particular concern of emissions is PM10 particles. PM10 particles are fine particulate matter of 10 microns or less which are associated with sickness and death from respiratory disease.

The Contractor shall furnish and post dust mitigation signs, which shall be, at a minimum, in accordance with the "AQMD Recommendations", attached hereto (See Appendix). Additional copies are available upon request from the Engineer. The sign shall include the Contractor's phone number which shall be maintained on a 24 hour basis. The sign message, size and design, including any deviations from the signage recommendations, shall be approved by the Engineer prior to fabrication.

The Contractor shall respond to complaints by mobilizing equipment and personnel at the construction site within 2 hours of each complaint to control fugitive dust.

Attention is directed to AQMD Rule 403.1, which applies to all contracts within the Coachella Valley Area of Riverside County. That AQMD Rule requires the Contractor to take specified dust control actions when prevailing wind speeds exceed 25 miles per hour. Wind forecasts, AQMD Rules and other related information are provided by AQMD at 1-800-CUT-SMOG and at www.aqmd.gov.

Any days on which the Contractor is prevented from working, due to the requirements of AQMD Rules, will be considered as non-working days, in accordance with Section 8-1.06, "Time of Completion" of the Standard Specifications.

The Contractor shall utilize the "Best Available Control Measures" of controlling fugitive dust, as prepared by the AQMD. For projects within the Coachella Valley, the "Reasonably Available Control Measures" may be employed, if effective within the context of the AQMD rules. However, if fugitive dust crosses the project boundary, more effective control measures, including the "Best Available Control Measures" shall be implemented.

A site-specific fugitive dust control plan shall be submitted to the Engineer for review and approval at least 10 days prior to the start of construction. Additionally, for projects outside of the Coachella Valley which meet the criteria for AQMD plan approval, the Contractor shall submit the dust control plan to AQMD for approval. AQMD plan submittal criteria is defined in AQMD Rule 403 as being for projects that will have disturbed surface area in excess of 100 acres, or for projects with a scope of work which requires the movement of more than 10,000 cubic yards of soil on each of any three working days.

A sample plan and other pertinent information is attached, and additional copies are available from the Engineer upon request. The fugitive dust control plan shall include the "Reasonably Available Control Measures" and "Best Available Control Measures" of controlling fugitive dust, as may be appropriate and necessary, including but not limited to watering, application of chemical dust suppressants, wind fencing, covering of haul vehicles, haul vehicle bed-liners, covering or chemically stabilizing stored materials, phased grading, planting of vegetation, the use of a 24 hour environmental observer, and track-out controls at locations where unpaved construction accesses intersect with paved roads. The use of chemical stabilizers, which are approved by all environmental regulatory agencies, and the use of reclaimed water is encouraged. If water is intended as a primary dust control tool, the dust control plan shall provide for at least one 2,000 gallon water truck for every 4 acres of disturbed soil, unless otherwise approved by the Engineer.

If the Construction Engineer determines that the project scope and the forecasted weather conditions are such that the Contractor's work is unlikely to be a source of dust emissions, the Construction Engineer has the authority to waive the requirements for submittal of a dust control plan and for placement of the dust control signs described herein. However, the

Contractors responsibilities for the control of fugitive dust and the other requirements of this Section may not be waived.

A completion notice will not be filed, and the final payment will not be made to the Contractor until the areas of disturbed soil on the construction site, including roadway shoulders, are suitably stabilized for long term control of fugitive dust.

The successful Contractor shall attend an AQMD PM10 Dust Control Program training session, and furnish evidence of attendance to the Engineer. Attendance at AQMD training seminars can be scheduled through AQMD at 1-866-861-DUST (1-866-861-3878) or by email to dustcontrol@aqmd.gov. Current AQMD certification of previous attendance will be accepted.

At that training session, the successful Contractor will be furnished with the AQMD prepared Rule 403 and Rule 403.1 implementation handbooks, which include the "Best Available Control Measures" and "Reasonably Available Control Measures", and other associated information, including a listing of suggested dust control related devices, materials and chemicals.

The signature of the Contractor on the Bid constitutes acknowledgement by the Contractor of the dust control requirements established by law and described herein, and the enforceability of those requirements.

Payment

When the contract includes a bid item for Dust Abatement, full compensation for conformance with these dust abatement requirements, including labor, equipment, materials, developing water supply and incidentals, shall be paid at the lump sum price for Dust Abatement, and no additional compensation will be allowed therefor.

When the contract does not include a bid item for Dust Abatement, full compensation for conformance with these dust abatement requirements, including labor, equipment, materials, developing water supply and incidentals, shall be considered as included in the various items of work, and no additional compensation will be allowed therefor.

Special Provisions Table of Contents

SPECIAL PROVISIONS.....	1
DESCRIPTION:	1
SPECIFICATIONS AND PLANS:	1
LIQUIDATED DAMAGES:	1
PARTIAL PAYMENT RESTRICTIONS:	1
PROJECT APPEARANCE:	2
GRAFFITI REMOVAL AND CLEANING:	2
DISPOSAL OF EXCESS EXCAVATION OR MATERIALS:.....	3
RECORD DRAWINGS:.....	4
SURVEY STAKING:.....	4
CONSTRUCTION PROJECT FUNDING IDENTIFICATION SIGN:	5
COOPERATION:	6
ITEMS OF WORK:	6
ORDER OF WORK:	6
WATER POLLUTION CONTROL (COLORADO RIVER BASIN REGION):.....	7
STREET SWEEPING:.....	10
TRAFFIC CONTROL SYSTEM/ PUBLIC CONVENIENCE/ PUBLIC SAFETY:	12
MAINTAINING TRAFFIC:.....	14
DEVELOP WATER SUPPLY:	15
CLEARING AND GRUBBING:.....	15
RELOCATE IRRIGATION SYSTEMS:	16
REMOVE TREES:	17
RELOCATE CHAIN LINK FENCE/GATE:.....	19
ADJUST EXISTING ROLLING GATES:.....	19
MAIL DELIVERY / MAILBOX RELOCATION:.....	20
MINOR CONCRETE:.....	20
ADJUSTMENT OF EXISTING WATER METER BOXES TO TO SIDEWALK FINAL GRADE:.....	23
REMOVE AND SALVAGE ROADSIDE SIGNS:	23
ROADSIDE SIGN - ONE POST:	24
MISCELLANEOUS DIRECTED WORK:	24
DE-MOBILIZATION:.....	24
OBSTRUCTIONS:	25
Adjustments to Grade for Obstructions	27

Avenida Florencita Sidewalk Project
Between Camino Aventura and Camino Campanero
Project No. C3-0050

In the Southeast Desert Hot Springs Community

SPECIAL PROVISIONS

DESCRIPTION:

In general, this project consists of constructing concrete sidewalk along the east side of Avenida Florencita between Camino Aventura and Camino Campanero in the Southeast Desert Hot Springs Community of the Coachella Valley. The work includes constructing concrete driveways, spandrel, curb, curb transitions, and curb ramps; remove and replace mailboxes, remove trees, relocating existing fence/gates and other work as may be required.

Traffic improvements include signing, and other work as may be required.

SPECIFICATIONS AND PLANS:

This project shall conform to the requirements of the May 2006 edition of the Standard Specifications and Standard Plans as issued by the State of California Department of Transportation.

Amendments to May 2006 Standard Specifications, updated June 20, 2012, are incorporated herein and can be found on the County of Riverside website during the Bid Period.

http://www.rctlma.org/trans/con_bid_advertisements.html

LIQUIDATED DAMAGES:

The Contractor shall diligently prosecute the work to completion before the expiration of **40** working days from the date stated in the "Notice to Proceed". The Contractor shall pay to the County of Riverside the sum of **\$5,000.00** per day, for each and every calendar days delay in finishing the work in excess of the number of working days prescribed above.

PARTIAL PAYMENT RESTRICTIONS:

Attention is direct to Section 9 1.06, "Partial Pavements," and 9 1.07, "Payment After Acceptance," of the Stand Specifications and these special provisions.

For the purpose of making partial payments pursuant to Section 9-1.06, "Partial Payments" of the Standard Specifications, the amount set forth for all Lump Sum items of work, shall be deemed to

be maximum total value of said contract item of work which will be recognized for progress payment purposes:

- A. Develop Water Supply \$2,000
- B. Clearing and Grubbing \$8,000

After acceptance of the contract pursuant to Section 7-1.17, "Acceptance of Contract" of the Standard Specifications, the amount, if any, payable for a contract item of work in excess of the maximum value for progress payment purposes herein above listed for said item, will be included for payment in the first estimate made after acceptance of the contract.

PROJECT APPEARANCE:

The Contractor shall maintain a neat appearance to the work.

In areas visible to the public, the following shall apply:

- A. When practicable, broken concrete and debris developed during clearing and grubbing shall be disposed of concurrently with its removal. If stockpiling is necessary, the material shall be removed or disposed of weekly.

- B. Trash bins shall be furnished for debris from structure construction. Debris shall be placed in trash bins daily. Forms or falsework that are to be re-used shall be staked neatly concurrently with their removal. Forms and falsework that are not to be re-used shall be disposed of concurrently with their removal.

Full compensation for conforming to the provisions in this section, not otherwise provided for, shall be considered as included in prices paid for the various contract items of work involved and no additional compensation will be allowed therefor.

GRAFFITI REMOVAL AND CLEANING:

The Contractor shall remove existing graffiti within the project limits and any new graffiti produced during the construction period of the project.

Contractor shall submit a method of graffiti removal plan to the Engineer for approval. Sand blasting will not be allowed. Methods may include but not limited to power washing, solvent washing, and painting over graffiti, as appropriate for the surface to be cleaned.

All graffiti shall be completely removed or obliterated and the area feathered out to hide any imperfections.

Graffiti shall be removed from, but not limited to, the surfaces listed as follows: bricks, cinder blocks, concrete sidewalks, pavement, bridge under passes, overhead structures, drainage channels, roadside signs, temporary construction signs, barricades, k-railing, traffic control devices, and all types of poles, and other objects within the project limits as directed by the

Engineer. Painting of k-railing for the purposes of graffiti removal shall not be considered as repainting as outlined in paragraph one of Section 12-3.08 and shall not be paid for as extra work.

Graffiti to be removed may include, but shall not be limited to: paint, signs, wood, metal, plastic, decals, gum, markers, crayons, ropes, chains, strings, wires, and tapes of any kind on an as needed basis.

All painting over graffiti must be done with exact color matches, so as not to show any blocking or shadowing of colors. Painting over graffiti is the preferred option on previously painted surfaces, and where solvents are unsuccessful at removing graffiti. Painting services shall be done on an as needed basis on the following types of surfaces, but not limited to: walls, hardscapes, poles, fences, bollards, railings, and buildings.

Paint shall be exact color match. Paint types may include oil base, water base and enamels as approved by the Engineer. Graffiti cover-up by paint will be allowed with appropriate type of paint at locations where graffiti cannot be removed only upon direction by the Engineer. All paint applications shall adhere to the manufacture's recommendations. All material and solutions shall be safe and biodegradable and approved by the Engineer.

Regional Water Quality Control Board (RWQCB) and Air Quality Management District (AQMD) regulations, as well as all NPDES required best management practices shall be complied with and followed.

The Contractor shall so conduct his operation as to cause the least possible obstruction and inconvenience to public traffic. The Contractor shall provide, erect and maintain barricades, lights, danger signals, and warning signs as deemed appropriate by the Engineer.

When necessary, the Contractor shall provide and erect safe and adequate scaffolding and equipment, barriers, and masking, required for the proper execution of the work. All scaffolding shall be properly braced and erected to insure the safety of the workmen and meet all appropriate OSHA regulations.

The Contractor shall respond and provide manpower for any urgent graffiti removal and cleaning notifications within two (2) working days.

Method of Payment:

Full compensation for conformance with these Graffiti Removal and Cleaning requirements, including labor, equipment, materials, necessary traffic control, and incidentals, shall be paid at the lump sum price for Traffic Control System, and no additional compensation will be allowed therefor.

DISPOSAL OF EXCESS EXCAVATION OR MATERIALS:

Excess earth excavation, pavement grindings and other excess materials resulting from construction operations shall be disposed of by the Contractor outside of the highway right of way, as provided in Section 7-1.13 of the Standard Specifications.

The second paragraph of Section 7-1.13 of the Standard Specifications is modified to read as follows:

When any material is to be disposed of outside the highway right of way, and the County of Riverside has not made arrangements for the disposal of such material, the Contractor shall first obtain written authorization from the property owner on whose property the disposal is to be made, and obtain all required permits from the jurisdictional agency(s) for said work, and he shall file with the Engineer said authorization or a certified copy thereof together with a written release from the property owner absolving the County of Riverside from any and all responsibility in connection with the disposal of material on said property. If the disposal of materials is to be made at an established disposal facility that is available for public use, the Contractor shall retain all authorizations and receipts from said disposal facility and shall provide copies to the Engineer upon request.

RECORD DRAWINGS:

The Contractor shall keep one clean set of bond originals to note any changes which take place during construction. These changes to the original plans and/or specifications shall be noted at the appropriate locations with the appropriate changes indicated in red pencil or ink. The Contractor shall note in large letters "RECORD DRAWINGS" on the Title Sheet of the plans. The job will not be finalized by the Engineer until these record drawings have been completed to the satisfaction of the Engineer. The changes shall be noted on the plans as the changes occur. The record drawings shall be submitted to the Resident Engineer, and become the property of the County at conclusion of the project.

Full compensation for maintaining and compiling the record drawings shall be considered to be included in other items of work and no additional compensation will be allowed therefor.

SURVEY STAKING:

County surveyors will establish external primary survey control marks and/or monuments to be used throughout the construction period. These control marks are to be protected by the contractor and will be used to set construction stakes. The control marks will also be used to make verification surveys at various stages of work.

Survey stakes and marks are set per the County's Survey Manual.

Contractor must submit a written request for County furnished construction staking before or once area to receive staking is ready for the installation of the construction stakes. The County will provide Contractor with a survey request form. Survey staking requests must be received from the Contractor a minimum of 2 business days prior to the installation of the requested construction staking. The County shall receive survey request from the contractor on normal business days, Monday through Thursday, 7:00 A.M. to 4:00 P.M. Requests received after 4:00 PM or on any day not previously noted, shall be considered as submitted at 7:00 AM the next business day.

A "business day" is defined by County Ordinance 358 (County Holidays, open and closed days, and hours of operation, etc.) and as revised by Board of Supervisor's resolution to alter days and/or hours for which a County office may be open for transaction of business.

Contractor must preserve primary and construction stakes and marks placed by the County. If the contractor fails to protect and/or destroys the primary and construction stakes and marks, the County shall replace them at the County's earliest convenience and deduct the cost of replacement from monies due the contractor:

CONSTRUCTION PROJECT FUNDING IDENTIFICATION SIGN:

The Contractor shall furnish and install **one (1)** Construction Project Funding Identification Signs (4' X 8'); the sign shall be installed at locations to be determined by the Engineer, within or near the project limits, in accordance with the relevant requirements of Section 56-2 of the Standard Specifications and the appropriate details of Standard Plans RS1 through RS4 for two post installation of sign, and as directed by the Engineer.

A reference exhibit displaying the text and colors of the sign will be provided to the Contractor prior to construction. The Contractor shall submit a copy of the final sign design for approval by the resident Engineer prior to fabrication.

The Contractor shall submit to the Engineer the final sign design in the form of an editable picture file in .eps format – Encapsulated PostScript file.

At the completion of the project, the signs will become property of the County. When directed by the Engineer, the Contractor shall remove all hardware from the sign. Posts and hardware shall become the property of the Contractor. The Contractor shall deliver and off-load the sign to the nearest County yard.

Method of Payment:

Full compensation for furnishing all labor, materials, tools, equipment, incidentals and for doing all the work including sign installation, transportation, maintenance, removal, delivery, excavation and backfill as specified in the Standard Specification and these Special Provisions for Construction Project Funding Identification Sign shall be considered as included in the various items of work applicable and no additional compensation will be allowed therefor.

COOPERATION:

Attention is directed to Section 7-1.14, "Cooperation" of the Standard Specifications and these Special Provisions.

The Contractor is hereby advised to cooperate with utility companies (Mission Springs Water District, and/or others) for adjusting water valves, and other facilities to grade.

The Contractor is advised to cooperate with property owners when working in front of their property.

Should construction be under way by other forces or by other Contractors within or adjacent to those limits, the Contractor shall cooperate with all the other Contractors or other forces to the end in order to avoid any delay or hindrance of work. The right is reserved to perform other or additional work at or near the site (including material sources) at any time, by the use of other forces.

ITEMS OF WORK:

ORDER OF WORK:

Order of work shall conform to the provisions in Section 5-1.05, "Order of Work" of the Standard Specifications and these Special Provisions.

Attention is directed to "Clearing and Grubbing" of these Special Provisions regarding private improvements within the project area. The Contractor shall work directly with the property owners to minimize the disturbance to the private improvements including driveways, fencing walls, landscaping and decorative features.

Attention is directed to "Cooperation" of these Special Provisions regarding coordinating with Sun Line Co. when relocating their bus bench and with property owners when working in their frontage.

Residential access

Attention is directed to "Public Convenience" of these Special Provisions regarding access to the residents in the vicinity of the project. For residents directly adjacent to the construction area, the Contractor shall coordinate with the residents to provide access to the properties.

Public Awareness Program

Attention is directed to "Public Convenience" of these Special Provisions regarding the Public Awareness Program and responding to communications with the public. The Contractor shall coordinate with the Resident Engineer on project signage, responding to comments and complaints from the public and other public awareness requests as needed.

Mail Delivery

Contractor shall notify the local Post Master at least 15 working days in advance of the start of construction. Contractor shall coordinate with the Post Master the method of mail delivery after construction begins. If mail delivery will be disrupted, rescheduled or held by the local post office, Contractor shall notify all affected residences at least 5 days in advance of the start of construction, in writing, disclosing any changes in delivery of the mail. The notice to residents shall be approved by the Engineer in advance of distribution.

WATER POLLUTION CONTROL (COLORADO RIVER BASIN REGION):

Throughout the term of this contract, the total land disturbance area of the project site is less than 1 acre. The Contractor shall comply with the Area-Wide Municipal Stormwater Permit NPDES No. CAS617002, hereafter referred to in this section as the "Municipal Permit", issued by the California Regional Water Quality Control Board (CRWQCB) – Colorado River Basin Region. This permit regulates both stormwater and non-stormwater discharges associated with Contractor's construction activities. A copy of the Permit may be obtained at the office of the County of Riverside Transportation Department, 14th Street Transportation Annex, 3525 14th Street, Riverside, California. (951) 955-6780, or may be obtained on the internet at: <http://www.swrcb.ca.gov/rwqcb7>

The Contractor shall comply with the requirements of the Municipal Permit, and all other applicable federal, state and local laws, ordinances, statues, rules, and regulations concerning water pollution control.

Contractor's Water Pollution Control Program (WPCP) shall be prepared by a Qualified SWPPP Developer in accordance with Section 3, "Preparing a Water Pollution Control Program (WPCP)", of the *Caltrans Stormwater Pollution Prevention Plan (SWPPP) and Water Pollution Control Program (WPCP) Preparation Manual (June 2011)*, which is available as a free download from: <http://www.dot.ca.gov/hq/construc/stormwater/manuals.htm>

WATER POLLUTION CONTROL MEASURES

- A. Work having the potential to cause water pollution shall not commence until the Contractor's WPCP has been reviewed and approved by the Engineer. The Engineer's review and approval of the Contractor's WPCP shall not waive any contractual requirements and shall not relieve the Contractor from achieving and maintaining compliance with all federal, state, and local laws, ordinances, statues, rules, and regulations. A copy of Contractor's WPCP shall be maintained onsite. When the WPCP or access to the construction site is requested by a representative of a federal, state, or local regulatory agency, Contractor shall make the WPCP available and Contractor shall immediately contact the Engineer. Requests from the public for the Contractor's WPCP shall be directed to the Engineer.
- B. Contractor's WPCP shall describe the Contractor's plan for managing runoff during each construction phase. Contractor's WPCP shall describe the Best Management Practices (BMPs) that will be implemented to control erosion, sediment, tracking, construction materials, construction wastes, and non-stormwater flows. BMP details

shall be based upon California Stormwater Quality Association's (CASQA) 2009 California Stormwater Quality BMP Handbook Subscription Portal (<http://www.cabmphandbooks.com>) or the Caltrans Construction Site BMP Manual (<http://www.dot.ca.gov/hq/construc/stormwater/manuals.htm>). Contractor's WPCP shall describe installation, operation, inspection, maintenance, and monitoring activities that will be implemented for compliance with the Municipal Permit and all applicable federal, state, and local laws, ordinances, statutes, rules, and regulations related to the protection of water quality.

- C. The Contractor's WPCP preparer shall have been trained to prepare WPCPs or SWPPPs and shall have previous experience with preparing SWPPP or WPCP requirements on a previous project.

The Contractor shall designate a Water Pollution Control Manager that shall have been trained to implement WPCP or SWPPP requirements. Contractor's Water Pollution Control Manager shall:

1. Be responsible for all water pollution control work.
2. Be the Engineer's primary contact for all water pollution control work.
3. Have the authority to mobilize resources (crews, supplies, equipment, etc.) to make immediate repairs of water pollution control measures or to supplement water pollution control measures to maintain compliance with all federal, state, and local laws, ordinances, and regulations related to the protection of water quality, including the Municipal Permit.

The WPCP shall contain all required and applicable certifications and evidence of training for the Water Pollution Control Manager, WPCP Developer, and all other employees working on the project receiving formal training or certification.

- D. Water Pollution Control Training: Contractor shall provide water pollution control training to Contractor's employees and subcontractors prior to their performing work on the work site. The water pollution control training shall be appropriate to the employee or subcontractor function and area of responsibility and shall address (as applicable):

1. Erosion Control (water and wind)
2. Sediment Control
3. Tracking Control
4. Materials & Waste Management
5. Non-Stormwater Discharge Management
6. Run-on and Run-off Control

- E. Monitoring and Reporting: Observations and inspections conducted by the Contractor's Water Pollution Control Manager shall be documented on the Construction Site Inspection Checklist included in Contractor's WPCP. A copy of each completed Construction Site Inspection Checklist shall be submitted to the Engineer within 24 hours of conducting the inspection.

General Requirements:

In the event the County incurs any Administrative Civil Liability (fine) imposed by the CRWQCB – Colorado River Basin Region, the State Water Resources Control Board, or EPA, as a result of Contractor's failure to fully implement the provisions of "Stormwater and Non-Stormwater Pollution Control", the Engineer, may, in the exercise of his sole judgment and discretion, withhold from payments otherwise due Contractor a sufficient amount to cover the Administrative Civil Liability including County staff time, legal counsel, consultant support costs and all other associated cost.

The Contractor shall be responsible for all costs and for any liability imposed by law as a result of the Contractor's failure to comply with the requirements set forth in "Water Pollution Control", including but not limited to, compliance with the applicable provisions of the Caltrans Handbooks, Municipal Permit, Federal, State, and local regulations. For the purpose of this paragraph, costs and liabilities include, but not limited to, fines, penalties, damages, and costs associated with defending against enforcement actions whether taken against the County or the Contractor, including those levied under the Federal Clean Water Act and the State Porter-Cologne Water Quality Act.

Within fifteen (15) working days after the award of the contract, the Contractor shall submit two (2) copies and one pdf. file of the WPCP to the Engineer for review and approval. The Contractor shall allow ten (10) working days for the Engineer to review the WPCP. If revisions are required as determined by the Engineer, the Contractor shall revise and resubmit the WPCP within three (3) working days of receipt of the Engineer's comments and shall allow ten (10) working days for the Engineer to review the revisions. The Contractor shall submit four (4) copies of the approved WPCP and one pdf file to the Engineer prior to notice to proceed. The Contractor must have an approved WPCP prior to the notice to proceed.

Unless otherwise directed by the Engineer or specified in these Special Provisions, the Contractor's responsibility for WPCP implementation shall continue throughout any temporary suspension of work ordered in accordance with Section 8-1.05, "Temporary Suspension of the Work", of the Standard Specifications. The Engineer may withhold progress payments or order the suspension of construction operations without an extension of the contract time, if the Contractor fails to comply with the requirements of "Water Pollution Control" as determined by the Engineer.

All BMP repairs shall be implemented by the Contractor within 72 hrs.

Method of Payment:

Payment for Water Pollution Control shall be on a lump sum basis and shall include full compensation for the work performed, including, developing, preparing, revising, obtaining approval of, and amending the WPCP, implementing, installing, constructing, operating, maintaining, and removing and disposing of temporary BMPs, performing the observations, inspections, sampling, analysis, reporting, and street sweeping, and as specified in the Caltrans Handbooks, Municipal Permit and these Special Provisions, and as directed by the Engineer.

STREET SWEEPING:

GENERAL

Summary

This work includes street sweeping.

The WPCP shall describe and include the use of street sweeping as a Water Pollution Control practice for sediment control and tracking control. Street sweeping shall also conform to all applicable AQMD requirements.

Submittals

At least 5 working days before starting clearing and grubbing, or other activities with the potential for tracking sediment or debris, submit:

- A. The number of street sweepers that will be used as described in the WPCP.
- B. Type of sweeper technology (or technologies).

Quality Control and Assurance

Retain the following records related to street sweeping and submit weekly to Engineer:

- A. Tracking Inspection Log
- B. Sweeping times and locations.
- C. Quantity of sweeping waste disposal.

CONSTRUCTION

Street Sweepers

Sweepers must use one of these technologies:

- A. Mechanical sweeper followed by a vacuum-assisted sweeper.
- B. Vacuum-assisted dry (waterless) sweeper.
- C. Regenerative-air sweeper.
- or
- D. Sweeping by hand is acceptable in lieu of A, B, and C above.

Operation

Street sweeping shall be conducted at:

- A. Paved roads at job site entrance and exit locations.
- B. Paved areas within the job site that flow to storm drains or water bodies.

Street sweeping shall be conducted, and sweeper(s) shall be available to operate at all times, for the following:

- A. During clearing and grubbing activities.

- B. During earthwork activities.
- C. During trenching activities.
- D. During roadway structural section activities.
- E. When vehicles are entering and leaving the job site.
- F. After soil disturbing activities.
- G. After observing offsite tracking of material.

Contractor's Water Pollution Control Manager shall inspect adjacent paved areas at job site entrances and exits and paved roadways within the job site on a minimum daily basis, and more frequently when activities that require street sweeping are being performed. Contractor's Water Pollution Control Manager shall maintain a "Tracking Inspection Log." Street sweeping shall be conducted:

- A. Within 1 hour, if sediment or debris is observed on paved areas or paved roadways.

At least one sweeper, in good working order, must be on the job site at all times when sweeping work may be required.

Perform street sweeping to minimize dust. If dust generation is excessive or sediment pickup is ineffective, water may be used but shall be contained, collected (e.g. vacuum), and properly disposed.

Material collected during street sweeping must be removed and disposed of under Section 7-1.13, "Disposal of Material Outside the Highway Right of Way" of the Standard Specifications.

Method of Payment:

Full compensation to conform with the requirements of this section shall be considered as included in the contract lump sum price paid for Water Pollution Control including furnishing all labor, materials, tools, equipment, and incidentals and for doing all the work involved in street sweeping, including disposal of collected material, as shown on the plans, as specified in the Standard Specifications, these Special Provisions, and as directed by the Engineer. Therefore, no additional compensation will be allowed for street sweeping.

TRAFFIC CONTROL SYSTEM/ PUBLIC CONVENIENCE/ PUBLIC SAFETY:

Contractor shall prepare construction staging and traffic control plans for review and approval by the Transportation Department.

Proposed plans shall be submitted by the Contractor for review and approval by the Transportation Department at least two weeks prior to the start of construction. The construction staging and traffic control plans shall be prepared, signed and stamped by a Civil Engineer or Traffic Engineer who is registered as such in the State of California, unless otherwise specifically allowed by the Engineer. The Contractor shall revise and implement the plans as directed by the Construction Engineer. Construction shall not begin until the Engineer provides Contractor with County approval of the plans.

Construction staging and traffic control plans shall be in accordance with the appropriate standards and specifications for construction staging, detour roads, traffic control, including the State of California Highway Design Manual, the manual on Uniform Traffic Control Devices 2012 Edition, the corresponding California Supplement, and subsequent modifications as adopted by the State of California Department of Transportation, Standard Plans and Standard Specifications, and the Work Area Traffic Control Handbook (WATCH), as published by Building News, Inc. Any requests for deviation from the established design standards or specifications are to be submitted to the Construction Engineer for review and approval prior to submission of the required plans.

With regard to the preparation and implementation of the plans, attention is especially directed to Sections 7-1.06, 7-1.08, 7-1.09, 7-1.11, 7-1.12 and Section 12 of the State of California Standard Specifications. Section 12-2.02 of the Standard Specifications is deleted.

Maintaining traffic shall conform to the provisions in 7-1.02 "Load Limitations", 7-1.06 "Safety and Health Provisions", 7-1.08 "Public Convenience", 7-1.09 "Public Safety", and 12-3.04 "Portable Delineators" of the Standard Specifications, the Manual on Uniform Traffic Control Devices 2012 Edition, the corresponding California Supplement, and subsequent modifications as adopted by the State of California Department of Transportation, the Section of these contract documents entitled "Insurance - Hold Harmless", and these Special Provisions.

All existing traffic control signs and street name signs shall be maintained in visible locations as directed by the Engineer.

No detours will be allowed, unless specifically allowed herein. The Contractor will be required to conduct his operations in such a manner that traffic will be permitted to pass through the work area with as little delay as possible.

All warning lights, signs, flares, barricades and other facilities for the sole convenience and direction of public traffic shall be furnished and maintained by the Contractor. All traffic control devices shall conform to and be placed in accordance with the Manual on Uniform Traffic Control Devices 2012 Edition, the corresponding California Supplement, and subsequent modifications as adopted by the State of California Department of Transportation.

All construction signs shall be either covered or removed when not required by the nature of the work or if no present hazard to the motorist exists.

The Contractor shall notify the appropriate regional notification center for operators of subsurface installations at least 2 working days, but not more than 14 calendar days, prior to commencing excavation for construction area sign posts. The regional notification centers include, but not limited to, the following:

Notification Center	Telephone Number
Underground Service Alert-Southern California (USA)	1-800-422-4133 1-800-227-2600 or 811

Excavations required to install construction area signs shall be performed by hand methods without the use of power equipment, except that power equipment may be used if it is determined there are no utility facilities in the area of the proposed post holes.

No payment for extra work will be allowed for work performed as specified in Section 12-2.02 (Flagging Costs) of the Standard Specifications. Flagging costs will be borne entirely by the Contractor.

The Contractor shall be responsible to distribute an information letter pertaining to the planned work to all affected residences and businesses, at least one week prior to commencing work adjacent to those residences and businesses. It shall be the responsibility of the Contractor to design the information letter, obtain design approval from the Engineer, print sufficient copies, and distribute the letter. The Transportation Department logo shall be included on the letter. A computer file of the logo may be obtained from the Engineer in .WPG, .DXF, .DGN or .DWG format. The letter shall be similar to the sample provided by the Engineer, and shall include a project description, the scope of work, the anticipated construction schedule, and other information as appropriate.

The Contractor shall post temporary no parking signs on affected streets 24 hours prior to work on those streets. The temporary no parking signs shall state the anticipated dates and hours of work on those streets.

Method of Payment:

Full compensation, except as otherwise provided herein, for conforming to the requirements of this article, including furnishing, installing and maintaining all traffic control devices shown on the construction staging and traffic control plans, including construction area signs, channelizers, portable changeable message signs, temporary pavement markers, temporary traffic stripes, shall be considered as included in the contract lump sum price paid for Traffic Control System, and no additional compensation will be allowed therefor.

MAINTAINING TRAFFIC:

Maintaining traffic shall conform to the provisions in Section 7-1.08, "Public Convenience", Section 7-1.09, "Public Safety" and Section 12, "Construction Area Traffic Control Devices" of the Standard Specifications and "Public Safety" of these Special Provisions.

Daily working hours shall be between the hours of 7:00 a.m. and 6:00 p.m., Monday through Friday, except legal holidays, as approved by the Engineer. Exceptions and specific work schedules shall be submitted to the Engineer for consideration.

Closure is defined as the closure of a traffic lane or lanes, including shoulder, ramp or connector lanes, within a single traffic control system. Lane closure is allowed only during contractor's work hours. All traveled lanes must be opened to traffic during non working hours excluding reconstruction area.

Closure shall conform to the provisions in "Traffic Control System" of these Special Provisions.

Local authorities shall be notified at least five (5) business days before work begins. The Contractor shall cooperate with local authorities to handle traffic through the work area and shall make arrangements to keep the work area clear of parked vehicles.

Personal vehicles of the Contractor's employees shall not be parked on the traveled way or shoulders including sections closed to public traffic.

When work vehicles or equipment are parked on the shoulder within six (6) feet of a traffic lane, the shoulder area shall be closed.

When work vehicles or equipment are parked on the shoulder within six (6) feet of a traffic lane, the shoulder area shall be closed with fluorescent orange traffic cones or portable delineators placed on a taper in advance of the parked vehicles or equipment and along the edge of the pavement at 25-foot intervals to a point not less than 25 feet past the last vehicle or piece of equipment. A minimum of 9 traffic cones or portable delineators shall be used for the taper. A W20-1 (ROAD WORK AHEAD) or W21-5b (RIGHT/LEFT SHOULDER CLOSED AHEAD) or C24 (CA) (SHOULDER WORK AHEAD) sign shall be mounted on a crashworthy portable sign support with flags. The sign shall be placed where designated by the Engineer. The sign shall be a minimum of 48" x 48" in size. The Contractor shall immediately restore to the original position and location a traffic cone or delineator that is displaced or overturned, during the progress of work.

If minor deviations from the lane requirement chart are required, a written request shall be submitted to the Engineer at least 15 days before the proposed date of the closure. The Engineer may approve the deviations if there is no significant increase in the cost to the County and if the work can be expedited and better serve the public traffic.

Designated County legal holidays are January 1st, the third Monday in January, February 12th, the third Monday in February, the last Monday in May, July 4th, the first Monday in September, the second Monday in October, November 11th, Thanksgiving Day, the Friday following Thanksgiving Day, December 24th and 31st when they fall on Monday, December 25th, December

26th and January 2nd when they fall on Friday, When a designated legal holiday falls on a Sunday, the following Monday shall be a designated legal holiday. When January 1st, February 12th, July 4th, November 11th, or December 25th fall on a Saturday, the preceding Friday shall be a designated legal holiday.

Full compensation for furnishing, erecting, maintaining, removing and disposing of the C43 (CA), W20-1, W21-5b and C24 (CA) signs shall be considered as included in the contract lump sum price paid for Traffic Control System and no additional compensation will be allowed therefor.

DEVELOP WATER SUPPLY:

Develop water supply shall conform to the provisions of Section 17 of the Standard Specifications and these Special Provisions.

Method of Payment:

Full compensation for developing water supply and furnishing watering equipment shall be considered as included in the lump sum price paid for Develop Water Supply and no additional compensation will be allowed therefor.

CLEARING AND GRUBBING:

Clearing and grubbing (including but not limited to trimming of trees, removing rocks shown on the plans, removing debris from pavement and gutters, required grading for matching sidewalk improvements grades, removal and/or relocation/resetting of all private facilities/improvements from the public right-of-way and on private property including landscape material and hardscape (i.e. gravel, brick), and relocation of existing irrigation behind sidewalk) shall conform to the provisions in Section 16 of the Standard Specifications.

Trees and bushes including tree stumps and roots, and rocks shall be removed as shown on the plans and as directed by the Engineer.

Any other trees that need to be removed not called out on the plans as tree removal will be included in the contract price paid for Clearing and Grubbing and no separate payment will be allowed therefor.

Removed tree trimmings, vegetation, and debris shall be the property of the Contractor and shall be disposed of by the Contractor, as provided in Section 7-1.13 of the Standard Specifications.

Attention is directed to Section 8-1.05, "Temporary Suspension of Work" of the Standard Specifications.

Nothing in this section shall relieve the Contractor from providing for public safety in conformance with the provisions in Section 7-1.09, "Public Safety" of the Standard Specifications.

For the purpose of making partial payments pursuant to Section 9-1.06, "Partial Payments" of the Standard Specifications, the amount set forth for the contract item of work hereinafter listed shall

be deemed to be maximum total value of said contract item of work which will be recognized for progress payment purposes:

Clearing and Grubbing - \$ 8,000.00

After acceptance of the contract pursuant to Section 7-1.17, "Acceptance of Contract" of the Standard Specifications, the amount, if any, payable for a contract item of work in excess of the maximum value for progress payment purposes herein above listed for said item, will be included for payment in the first estimate made after acceptance of the contract.

Method of Payment:

Full compensation, except as otherwise provided herein, for conforming to the requirements of this article including all labor, equipment, materials and incidentals, for performing clearing and grubbing including but not limited to **trimming of trees, removing rocks shown on the plans, removing debris from pavement and gutters, required grading for matching sidewalk improvements grades, removal and/or relocation/resetting of all private facilities/improvements from the public right-of-way and on private property including landscape material and hardscape (i.e. gravel, brick), and relocation of existing irrigation behind sidewalk**, shall be considered as included in the contract price paid per lump sum for Clearing and Grubbing and no additional compensation will be allowed therefor.

RELOCATE IRRIGATION SYSTEMS:

Relocation of existing irrigation systems shall be performed when encountered or where directed by the Engineer.

Attention is directed to Section 20-5.025, "Maintain Existing Water Supply", of the Standard Specifications.

Existing irrigation facilities that are damaged by the contractor's operation shall be reported immediately to the Engineer, and shall be adjusted and repaired as necessary and as directed by the Engineer. Existing irrigation facilities that are in conflict with the planned improvements shall be relocated as required, and as directed by the Engineer.

The Contractor shall be responsible for the restoration of landscaping and irrigation facilities in kind. This shall include relocation of irrigation pipes, pipe connections, sprinklers and associated equipment, re-seeding of disturbed lawn and landscaped areas that are damaged by construction activities and other such work as may be required.

Method of Payment:

Full compensation for conforming to the requirements of this article including all labor, equipment, materials and incidentals, to Relocate Irrigation Systems shown on the plans or as directed by the engineer, shall be included in the contract lump sum amount paid for 'Clearing and Grubbing' and no additional compensation will be allowed therefor.

REMOVE TREES:

Trees and bushes including tree stumps and roots shall be removed as shown on the plans and as directed by the Engineer.

Any other trees that need to be removed not called out on the plans as tree removal will be included in the contract price paid for Clearing and Grubbing and no separate payment will be allowed therefor.

Removed trees and trimmings shall be the property of the Contractor and shall be disposed of by the Contractor, as provided in Section 7-1.13 of the Standard Specifications.

Any tree or bush removal or trimming between March 1st and September 15th will require a preconstruction survey for nesting birds. The Contractor shall schedule accordingly.

The nesting survey, if required, will be provided by Riverside County staff.

Regulatory Requirements

Attention is directed to the Federal Migratory Bird Treaty Act (15 USC 703-711) 50 CFR Part 21 and 50 CFR Part 10, and the California Department of Fish and Game Code Sections 3503, 3513 and 3800, that protect migratory birds, their occupied nests, and their eggs from disturbance or destruction.

Construction

Ground disturbance, tree, shrub and/or vegetation removal that occurs between March 1st and September 15th will not commence until a preconstruction survey for nesting birds has verified that no active nests have been located or the Engineer has approved the beginning of work. If an active nest is located, construction within 500 feet of the nest must be avoided until the nest has been vacated and the young are independent of their parents.

Between March 1st and September 15th, the Contractor shall notify the Engineer 15 working days prior to beginning work disturbing structures, the ground or vegetation. The Engineer will approve the beginning of work disturbing the ground or vegetation between March 1st and September 15th.

The Contractor shall use exclusion techniques directed by the Engineer to prevent migratory birds from nesting on the ground, on structures or in trees, shrubs or other vegetation within the project limits.

If evidence of bird nesting is discovered, the Contractor shall not disturb the nesting birds or nests until the birds have naturally left the nests. If evidence of migratory bird nesting is discovered after beginning work, the Contractor shall immediately stop work within 500 feet of the nests and notify the Engineer. Work shall not resume until the Engineer provides a written notification that work may begin at or adjacent areas of the discovered bird nest locations.

Attention is directed to Section 8-1.05, "Temporary Suspension of Work" of the Standard Specifications.

Nothing in this section shall relieve the Contractor from providing for public safety in conformance with the provisions in Section 7-1.09, "Public Safety" of the Standard Specifications.

Method of Payment and Penalties

If, in the opinion of the Engineer, completion of the work is delayed or interfered with by reason of the Engineer's delay in approving the disturbance structures, ground or vegetation, the Contractor will be compensated for resulting losses, and an extension of time will be granted, in the same manner as provided for in Section 8-1.09, "Right of Way Delays" of the Standard Specifications.

Preventing nesting by using appropriate exclusion techniques will be paid for as extra work as provided in Section 4-1.03D, "Extra Work" of the Standard Specifications.

Notwithstanding any other remedies authorized by law, the Department may retain or withhold monies due the Contractor under the contract, in an amount determined by the Department, up to and including the entire amount of penalties proposed, assessed, or levied as a result of the Contractor's violation of Federal or State law, regulations or requirements. Funds may be retained by the Department until final disposition has been made as to the penalties. The Contractor shall remain liable for the full amount of penalties until such time as they are finally resolved with the entity seeking the penalties. Upon final disposition, the Department shall inform the Contractor of the withheld amount.

Penalties as used in this section, "General Migratory Bird Protection" shall include fines, penalties, and damages whether proposed, assessed, or levied against the Department or the Contractor. Penalties shall also include payments or costs incurred in settlement for alleged violations of applicable laws, regulations, or requirements. Costs incurred could include sums spent instead of penalties, in mitigation or to remediate or correct violations.

Exclusion devices, nesting prevention measures, and nest removal that are ordered by the Engineer shall be compensated per Section 11 "Payment for Extra work (Force Account Basis)" of the General Provisions.

Full compensation, except as otherwise provided herein, for conforming to the requirements of this article, including all labor, equipment, materials and incidentals shall be considered as included in the contract unit price paid per each for Remove Tree and no additional compensation will be allowed therefor.

RELOCATE CHAIN LINK FENCE/GATE:

Fence and Gate relocation shall conform to Section 80, "Fences" of the Standard Specifications, the approved construction plans, and as directed by the Resident Engineer. Full compensation for the relocation of existing fence shall include construction of fence posts concrete footings, the replacement of hardware and the fence (if necessary) as directed by the Engineer.

Damaged fence/gates as directed by the Engineer shall be replaced with material that is similar or better in quality than the existing fences.

Where it is necessary and/or required by property owner, temporary fence/gate shall be placed for the safety of the homeowner or the protection of owner's pets. The cost for this temporary fencing shall be considered as included in the contract unit prices paid per linear feet for Relocate Chain Link Fence.

Method of Payment:

The contract unit price paid per linear foot for Relocate Chain Link Fence shall include full compensation for furnishing all labor, materials, tools, and equipment and for doing all the work involved in relocating fence/ gates, including any excavation and backfill required, concrete footings, as specified in the Standard Specifications and these Special Provisions, and as directed by the Engineer, and no additional compensation will be allowed therefor.

ADJUST EXISTING ROLLING GATES:

Existing rolling gates and tracks shall be removed and relocated as shown on the construction plans and as directed by the Engineer. Adjust gates as needed to smoothly slide over proposed improvements, or as directed by the Engineer.

The excess materials from the removals shall become the property of the Contractor. If during construction operations the Contractor damages the existing fencing/gates and the material is determined to be damaged or not suitable for relocation or replacement, the Contractor shall provide fencing/gates in a similar suitable material (and color) as determined by the Engineer at no additional cost to the County.

For rolling/sliding gates, adjust gates as needed to slide or roll clear of proposed improvements, or as directed by the Engineer.

If the rolling/sliding gate is inoperable or in a damaged condition and will not close or operate, Contractor shall document the existing condition to the satisfaction of the Engineer. Contractor shall relocate if necessary but will not be required to repair beyond the existing condition. Contractor shall not be required to paint or repair gates in poor condition unless directed to do so by Engineer.

Method of Payment:

The contract bid unit price per each for Adjust Existing Rolling Gate shall include full compensation for furnishing all labor, tools, material, equipment, and incidentals, and for doing all work involved, all reworking and adjustments to finish grade of existing gate which may include

portions beyond fence/gate opening to accomplish replacing gate in working condition as directed by the Engineer and no additional compensation will be allowed therefor.

MAIL DELIVERY / MAILBOX INSTALLATION:

Coordination

Contractor shall notify the local Post Master at least 15 working days in advance of the start of construction. Contractor shall coordinate with the Post Master the method of mail delivery after construction begins. If mail delivery will be disrupted, rescheduled or held by the local post office, Contractor shall notify all affected residences at least 5 days in advance of the start of construction, in writing, disclosing any changes in delivery of the mail. The notice to residents shall be approved by the Engineer in advance of distribution.

Existing mailbox shall be removed and reset on temporary portable mount, typically a timber post supported in five gallon can or bucket, in accordance with Section 15 of the Standard Specifications and these Special Provisions, or as directed by the Engineer. During construction operations, the portable mount shall be moved as necessary to clear the Contractor's operations, but at all times shall be easily accessible for mail delivery. When construction is complete, the new mailboxes shall be installed at their final positions as directed by the Engineer.

New mailbox locations shall conform to the approved plans and as directed by the Engineer.

New mailboxes shall consist of T1 or C1 standard mailbox with a new single 2" metal post. The cost of a new mailbox and support, as described above, shall be at the Contractor's expense.

Method of Payment:

Full compensation for furnishing and installing mailboxes shall be considered as included in the contract unit bid price paid per each for Remove and Replace Mailbox and shall include full compensation for furnishing all labor, material, tools, equipment, and incidentals and for doing all the work involved including removing and temporarily relocating the existing boxes, installation to final locations including all necessary concrete, excavation, and backfill, metal post, as specified in the Standard Specifications and these Special Provisions, and as directed by the Engineer.

MINOR CONCRETE:

New and reconstructed concrete **curb ramps, spandrel, curb, curb transition, sidewalk, retaining curb behind sidewalk/ramp, driveway approaches and driveways** shall be constructed in accordance with the County of Riverside Road Improvement Standards and Specifications, in conformance with Sections 51, 73 and 90 of the Standard Specifications, the plans, these Special Provisions, and as directed by the Resident Engineer.

Class 2 concrete shall be used for spandrel.

Class 3 concrete shall be used for curb ramps, curb, sidewalk, retaining curb behind sidewalk/ramp, driveway approaches and driveways.

The area behind and along the concrete improvements shall be filled and compacted with native or select material and graded to match and provide a smooth transition from the edge of the new improvements, to the satisfaction of the Engineer.

Preparation of subgrade for the concrete structures shall be done in conformance with the requirements of Section 73-1.02 of the Standard Specifications. Unless otherwise specified, all curbs and gutters will be backfilled as shown on the plans.

Excess material resulting from the excavation of the subgrade shall be disposed of as elsewhere provided in these Special Specifications.

The Contractor is responsible for meeting requirements of all American with Disability Act (ADA).

Construction of concrete curb ramps, spandrel, curb, curb transition, sidewalk, retaining curb behind sidewalk/ramp, driveway approaches and driveways shall include, but not be limited to, the following:

- 1) Removal and disposal of existing concrete curb ramps, spandrel, curb, curb transition, sidewalk, retaining curb behind sidewalk/ramp, driveway approaches and driveways, and existing soil and aggregate as required;
- 2) Establishing grades, and assuring that all grades are met;
- 3) Performing all grading and compaction – including all required aggregate import, as directed by the Engineer and in accordance with County Standard 403;
- 4) Construction of new concrete curb ramps, spandrel, curb, curb transition, sidewalk, retaining curb behind sidewalk/ramp, driveway approaches and driveways;
- 5) All scoring/grooving and required saw cutting;
- 6) Repair of existing asphalt and PCC surfacing;
- 7) Installing 1/2" wide expansion joints;
- 8) All landscaping, and related work, to return the area adjacent to the sidewalk, curbs, ramps, driveways, driveway approaches, curb and/or curb and gutter to its original condition and to conform the area to the new improvements;

At a minimum, the area from the BCR to ECR shall meet all required ADA standards. Therefore, to conform to existing conditions and/or to achieve the required four-foot level area (maximum of 2.0% crossfall) at the top portion of the curb ramp, it may be necessary to extend the work beyond the BCR/ECR in certain instances.

Payment for Curb Ramp Detectable Warning Surface (Truncated Domes) installed on new Curb Ramps shall be considered as included in the contract unit price paid for Minor Concrete (Curb Ramp) of the different kinds provided in the bid items list, and no separate payment will be made therefor.

Curb ramp detectable warning surface must be:

1. Yellow color complying with Federal Standard 595B, Color No. 33538.
2. Raised truncated domes.

The manufacturer must provide a written 5-year warranty for detectable warning surface, guaranteeing replacement when there is defect in the dome shape, color fastness, sound-on-cane acoustic quality, resilience, or attachment. The warranty period will begin upon acceptance of the contract.

Installation of curb ramp detectable warning surface must comply with the manufacturer's recommendations.

Driveway approaches shall be constructed as shown on the plans or as directed by the Engineer.

With the exception of unimproved driveways and concrete driveway aprons, surfacing for driveways shall consist of a replacement in kind of the existing driveway surfacing, using the contract item material most resembling that in place on the driveway. If there is no item in the contract for a similar material or if a special driveway surfacing is requested by the Engineer, said special surfacing shall be furnished and placed by the Contractor, and the cost thereof will be paid for as extra work as elsewhere provided herein.

Except as noted above, all other driveway work shall be paid for on the basis of the applicable contract item and no additional allowance will be made therefor.

Full compensation for the sidewalk construction shall include the placing of private drain through concrete curb to tie in existing drain pipe as directed by the Engineer and no additional compensation will be allowed therefor.

Method of Payment:

The contract payment per square foot for Minor Concrete (Driveway) shall include full compensation for the construction of the driveway approaches and the concrete driveways and no additional compensation will be allowed therefor.

Full Compensation for furnishing and installing metal handrail as shown on the plans details shall be considered as included in the contract price paid per each for Construct Pedestrian Ramp with Handrail, and no additional compensation shall be allowed therefor.

Payment for concrete retaining curb behind curb ramps shall be considered as included in the contract prices paid per each for the different kinds of Minor Concrete (Curb Ramps) provided in the bid items list and Construct Pedestrian Ramp with Handrail and not additional compensation will be allowed therefor.

Payment for concrete retaining curb behind sidewalk shall be considered as included in the contract price paid per square foot for Minor Concrete (Sidewalk) and not additional compensation will be allowed therefor.

Payment for constructing pavement joint as shown on the plans Detail 'C', Pavement Joint Detail, shall be considered as included in the contract prices paid per square foot for Minor Concrete (Spandrel), per each for Minor Concrete (Curb Ramp) of the different kinds as provided in the bid items list, and per linear foot for Minor Concrete (Curb) and Minor Concrete (Curb Transition); including sawcutting, removing, grinding and proper disposing of existing asphalt concrete

pavement, replacing with 0.33' of Hot Mix Asphalt, 3/4" PG 70-10 Type A, and no additional compensation shall be allowed therefor.

The contract unit bid prices paid per each for Minor Concrete (Curb Ramp) of the different kinds as provided in the bid items lists and Construct Pedestrian Ramp with Handrail; per square foot for Minor Concrete (Driveway), Minor Concrete (Spandrel), and Minor Concrete (Sidewalk); and per linear foot for Minor Concrete (Type C Curb), and Minor Concrete (Curb Transition), shall include full compensation for furnishing all labor, equipment, including the removal of existing concrete curb, curb ramps, spandrel, sidewalk, or driveway approaches, excavation, placing of suitable fill to prepare the sub-grade, furnishing and placing expansion joint material, materials and tools, and incidentals, and for doing all the work involved in the construction and complete in place as shown on the plans, or as herein specified, or as directed by the Engineer.

ADJUSTMENT OF EXISTING WATER METER BOXES TO TO SIDEWALK FINAL GRADE:

Conflicting water meter boxes owned by Mission Springs Water District (MSWD) shall be adjusted by contractor. However, if the required adjustment requires more than 2" (+/-) from the existing grade, the owner (MSWD) shall be contacted and will perform the necessary adjustment.

Contact Danny Friend at: (760) 329-6448.

Full compensation for all costs, including labor, equipment, materials and incidentals, required to comply with the requirements of this section above shall be considered as included in the contract price paid per square foot for Minor Concrete (Sidewalk), and no additional compensation will be allowed therefor.

REMOVE AND SALVAGE ROADSIDE SIGNS:

Existing roadside signs shall be removed and salvaged as shown on the plans.

Existing roadside signs at locations shown on the plans to be removed shall not be removed until replacement signs have been installed or until the existing signs are no longer required for direction of public traffic, unless otherwise directed by the Engineer.

The Contractor shall deliver County owned signs to be salvaged to the nearest County Maintenance Yard as directed by the Engineer.

The contract unit price paid per each for remove and salvage Roadside Signs shall include full compensation for furnishing all labor, materials, tools, equipment and incidentals and for doing all the work including excavation and backfill as specified in the Standard Specification and these Special Provisions and no additional compensation will be allowed therefor.

ROADSIDE SIGN - ONE POST:

The Contractor shall furnish and install roadside signs at the locations shown on the plans or as directed by the Engineer, in conformance to the provisions in Section 56-2 "Roadside Signs," of the State Standard Specifications, Palm Desert Standard Drawings, and these Special Provisions.

All Signs shall be installed on new square perforated steel tube posts in accordance with County Standard No. 1222.

Street name signs shall be furnished and installed in conformance with County Standard No. 1221 as shown on the plans, as specified in these Special Provisions and as directed by the Resident Engineer.

All roadway signs shall have retroreflective sheeting. Except as stated below, the retro-reflectivity for all roadway signs, both temporary and permanent installations, shall meet or exceed ASTM Standard D 4956 Type III (3M Co. High Intensity Grade or approved equal). The retroreflectivity for R1-1 ("STOP") signs and W3-1 (Stop Ahead) signs shall meet ASTM Standard D 4956 Type IX (3M Co. Diamond Grade or approved equal).

Method of Payment:

The contract unit price paid per each for Roadside Sign - One Post, including street name signs, shall include full compensation for furnishing all labor, materials, tools, equipment, and incidentals and for doing all the work including all necessary concrete excavation and backfill as specified in the Standard Specifications.

MISCELLANEOUS DIRECTED WORK:

Miscellaneous directed work shall consist of necessary work that is not included in other contract bid items, as determined by the Engineer. Miscellaneous directed work shall be performed as directed by the Engineer and in accordance with the applicable standards and specifications.

Method of Payment:

Payment for implementing miscellaneous directed work will be paid for on a force account basis, in accordance with Section 9-1.03 of the Standard Specifications, up to the fixed bid price, for the work performed.

DE-MOBILIZATION:

De-mobilization shall consist of the completion of all final construction, cleanup work, incidentals to the project site(s), and administrative work required to secure the project for termination and acceptance by the Engineer, including, but not limited to the following:

1. Satisfactory completion of Finishing Roadway in accordance with Section 22 "Finishing Roadway" of the Standard Specifications.

2. Removal of all temporary facilities, temporary utilities, temporary BMPs, plant, equipment, surplus material, construction debris and similar from project limits and adjacent property, as required and as directed by the Engineer.
3. Restoration of all temporary roads and haul routes and construction storage and office areas, etc. to original or better condition.
4. Completion of record of drawings (as-builts), to the satisfaction of the Engineer.
5. Submission of final Disadvantaged Business Enterprise report to the Engineer.
6. Submission of final certified payroll documents to the Engineer.
7. Submission of property owner releases, as required by the Engineer.
8. Completion of the requirements of permits issued by other agencies.
9. Satisfactory completion of punch list items, all construction and administrative items of work.

De-Mobilization shall include the satisfactory completion of all items of work, but shall not be interpreted as being a separate payment for work that is paid under separate contract items. The contract item for De-Mobilization is intended for project close-out activities.

Method of Payment

Payment for De-Mobilization will be made on a lump-sum basis in the amount of the fixed bid price after satisfactory completion of the above listed items. Payment for De-Mobilization will be included in the final pay estimate and payment. No partial payments will be made for De-Mobilization

OBSTRUCTIONS:

Attention is directed to Sections 8-1.10, "Utility and Non-Highway Facilities", and 15, "Existing Highway Facilities" of the Standard Specifications and these Special Provisions.

Existing utility and privately owned facilities shall be protected in accordance with Section 7-1.11, "Preservation of Property" and these Special Provisions. The Contractor is also responsible to protect those facilities that are to be relocated by others prior to or during construction, and shall protect those facilities in both their existing and their ultimate locations. The Contractor shall cooperate with owners and their Contractors of utility and privately owned facilities, for the relocation of said facilities, in accordance with Section 7-1.14, "Cooperation" of the Standard Specifications.

All water valves and covers, gas valves and covers, sewer manholes, survey monuments, survey markers and any other utility appurtenances shall be protected in place.

Adjustment of Existing Water Meter boxes to Sidewalk Final Grade:

Conflicting water meters owned by Mission Springs Water District (MSWD) shall be adjusted by contractor. However, if the required adjustment requires more than 2" (+/-) from the existing grade, the owner (MSWD) shall be contacted and will perform the necessary adjustment.

Contact Danny Friend at: (760) 329-6448.

The Contractor's attention is directed to the existence of certain underground facilities that may require special precautions be taken by the Contractor to protect the health, safety and welfare of workmen and the public. Facilities requiring special precautions include, but are not limited to: conductors of petroleum products, oxygen, chlorine, and toxic or flammable gases; natural gas in pipe lines greater than 6 inches in diameter or pipe lines operating at pressures greater than 60 psi (gage); underground electric supply system conductors or cables either directly buried or in duct or conduit which do not have concentric neutral conductors or other effectively grounded metal shields or sheaths; and underground electrical conductors with potential to ground of more than 300 volts. The Contractor shall notify the Engineer at least twenty-four hours prior to performing any work in the vicinity of such facilities.

Attention is directed to the requirements of Government Code Sections 4216-4216.9 pertaining to existing utility facilities.

The Contractor shall assume that every house, building and lot within the project limits has utility service pipes and conductors (laterals), and that utility main and trunk facilities exist within the project limits. The Contractor shall determine if it is warranted to determine the exact location of these utility service laterals and existing main lines, unless directed by the Engineer to pot-hole at specific locations, or as otherwise required herein. The Contractor will not be directly reimbursed for determining the exact location of the utility main lines or services laterals but shall include any compensation for this work in the contract price paid for the various items of work. Any damage to existing main lines or service laterals for which pot-holing was not performed shall be considered damage due to not using reasonable care and the damage shall be repaired at the Contractor's expense.

The Contractor shall conduct his operations with the assumption that underground utility facilities exist within the project limits. The Contractor shall exercise caution and best construction practices for safety and for protection of underground facilities. The approximate locations of underground utility facilities, as shown on the plans, are based on information provided by the respective owners, listed below. The Contractor shall also utilize the markings of the regional notification center (Underground Service Alert), and above-ground utility appurtenances to determine the existence and approximate location of underground utilities.

No excavation shall be made within 4 feet of any underground utilities, as shown on the plans and/or marked by Underground Service Alert, unless and until such utilities have been positively located as to horizontal and vertical position. This requirement applies to all underground electric, natural gas, toxic or flammable gas, chlorine, oxygen or petroleum facilities.

Forty-eight hours prior to beginning construction, the Contractor shall notify the following agencies:

Underground Service Alert	800-227-2600
Southern California Edison Company	951-928-8318
Southern California Gas Company	909-335-7561
Verizon Communications	951-925-5319
Time Warner Cable	951-549-3977
Mission Springs Water District	760-329-6448

Method of Payment

Full compensation for all costs, including labor, equipment, materials and incidentals, required to comply with the requirements of this section above, including protection of water valves and covers, gas valves and covers, sewer manholes, survey monuments, survey markers and any other utility appurtenances, shall be considered as included in the various items of work, and no additional compensation will be allowed therefor.

Adjustments to Grade for Obstructions

The Contractor shall adjust to finish grade any valve covers encountered within the project limits, as required, for those utility valves that are provided with slip cans and are adjustable without the replacement of parts or the removal of concrete collars. In cases where the owning utility company insists upon upgrades in the standards, or when additional parts or the removal of concrete collars are required for the adjustment, said adjustment will be the responsibility of the owning utility company.

Communication and coordination with the owning utility company shall be the responsibility of the contractor.

For public safety, traffic shall not be allowed on temporary or permanent pavement until all manholes are either adjusted to grade or otherwise protected, as approved by the Engineer. The Contractor shall adjust to grade manholes and valves when and as necessary for the protection of the traveling public during construction, and shall coordinate all work on said facilities with the owning utility companies. This requirement is intended for traffic that is to be allowed on temporary surfaces during the course of construction. Final adjustment to grade will be the responsibility of the owning utility company, except as provided herein.

Said work shall be performed in accordance with Section 15-2.05A, "Frames, Covers, Grates, and Manholes" of the Standard Specifications. Full compensation for adjustment of valve covers shall be considered as included in the contract price paid for asphalt concrete, or applicable items of work in the event that there is no asphalt concrete bid item, and no additional compensation will be allowed therefor.

All existing utility facilities shall be protected from damage by the Contractor's operations.

Unless otherwise provided herein, the owning utility companies will not be obligated to lower their surface utilities (manholes and valve covers) for Contractor's grading, grinding and/or

paving operations. The contractor shall lower surface facilities, including manholes and valve covers, to facilitate construction, and the following shall apply:

1. Contractor shall coordinate all work with the utility owner.
2. Contractor shall be responsible for all costs and shall be responsible for any damage caused to the owner's facilities. If the Contractor observes any pre-existing damage to the utility facilities, the Contractor shall notify the Engineer and the utility owner of that damage prior to performing additional work on the facility.
3. Contractor shall, after removing grade rings and covers, arrange for pickup by, or delivery to, the owner's yard. Any and all concrete collars removed by the Contractor shall become the property of the Contractor, and shall be disposed of as specified elsewhere in these special provisions.
4. The Contractor is advised that he is responsible for ensuring that construction materials do not enter the utility owner's facilities. The Contractor shall install traffic bearing steel plates for this purpose, and provide all coordination and transportation necessary. It is recommended that the Contractor request the utility owner to provide such steel plates. If the Contractor provides steel plates, it shall be the Contractor's responsibility to coordinate with the utility owner for the return of the steel plates to the Contractor after final adjustment to grade. If the Contractor utilizes utility owner's steel plates, and if the Contract items of work include adjustment to final grade, the Contractor shall return the steel plates to the Utility owner's yard, or as otherwise arranged with the Utility owner.
5. Prior to paving or covering the plated utility facility, the Contractor shall tie-out the facility utilizing a method acceptable to the utility owner and provide notes and data of all covered facilities to both the utility owner and the Engineer.
6. The Contractor shall notify the utility owner, upon completion of the Contractor's work, when the utility owner may move in to make the final adjustments to grade.
7. The requirements for lowering of surface facilities shall not apply to vaults. The Contractor shall notify the utility owner of the need to make adjustments to such major facilities.
8. The Contractor is reminded that the utility facilities are owned by public and private utility companies that operate their facilities within public rights of way. The utility owner's preferences with regards to the handling of its facilities shall be complied with to the greatest extent feasible.

Method of Payment

Full compensation for initial lowering of surface utilities facilities shall be considered as included in the contract price paid for asphalt concrete, or applicable items of work in the event that there is no asphalt concrete bid item, and no additional compensation will be allowed therefor.

Appendix A
AQMD Recommendations

Dust Abatement Attachments

Table of Contents

<u>Description</u>	<u>Page</u>
Signage Recommendation (AQMD document, modified)	DA1
Sample Dust Control Plan (AQMD sample)	DA5
Dust Control Plan Review Checklists (AQMD document)	DA6
Reasonably Available Control Measures (from Rule 403 Implementation Handbook)	DA10
Best Available Control Measures (from Rule 403 Implementation Handbook)	DA16
Best [Reasonably] Available Control Measures for High Winds Conditions (from Rule 403 Implementation Handbook)	DA22
Track Out Control Options (from Rule 403 Implementation Handbook)	DA26

AQMD SIGNAGE RECOMMENDATIONS**November, 2001**

Plan holder shall post signage at specified locations on the subject property in accordance with the standards specified below. The exception to the standards is that all letters shall be 4 inches high, with the names and telephone numbers of appropriate contacts and services in bold print, as indicated in the standards. These signs shall also include the SCAQMD toll free complaint line 1-800-CUT-SMOG (1-800-288-7664) and the telephone number for the Environmental Observer. These signs shall be posted within 50 feet of the curb on all four (4) corners of the subject property.

For each Dust Control Plan aggregating less than, or equal to, ten (10) acres:

1. The applicant shall install a sign on such property which is visible to the public that meets the following requirements:
 - (a) Such sign shall measure at least four (4) feet wide by four (4) feet high and conform to the specifications in 1 (a) below.

For each Dust Control Plan aggregating over ten (10) acres:

2. The applicant shall install a sign on such property which is visible to the public that meets the following requirements:
 - (a) Such sign shall measure at least eight (8) feet wide by four (4) feet high and conform to the specifications in 1 (b) below.

THE SIGN SHALL CONFORM TO THE FOLLOWING REQUIREMENTS:

1. **The sign boards shall be constructed with materials capable of withstanding the environment in which they are placed.**
 - (a) For 4' x 4' signs, the District recommends the following:
 - I. 3/4" A/C laminated plywood board
 - II. Two 4" x 4" posts
 - III. The posts should be attached to the edges of the plywood board with at least 2 carriage bolts on each post.
 - IV. The front surface of the sign board should be painted in the contrasting color of a white background with black lettering.
 - (b) For 4' x 8' signs, the District recommends the following:
 - I. 1" A/C laminated plywood board
 - II. Two 5" x 6" posts
 - III. The posts should be attached to the 4' edges of the plywood board with at least 2 carriage bolts on each post.
 - IV. The front surface of the sign board should be painted in the contrasting color of a white background with black lettering.

2. The sign board shall be installed and maintained in a condition such that members of the public can easily view, access, and read the sign at all times until the expiration date of the Dust Control plan.

- (a) For 4' x 4' signs, the District recommends the following:
- I. The lower edge of the sign board should be mounted at least 2' above the existing ground surface to facilitate ease of viewing.
 - II. The posts should be set in a hole at least 3' deep with concrete footings to preclude downing by high winds.
 - III. On the construction site, the sign should be positioned such that nothing obstructs the public's view from the primary street access point.
 - IV. For construction projects that are developed in phases, the sign should be moved to the area that is under active construction.
 - V. In situations where all phases of the construction project are completed on a property prior to expiration of the Dust Control Plan, a written request for cancellation of the Dust Control Plan must be submitted to the Engineer.
- (b) For 4' x 8' signs, the District recommends the following:
- I. The lower edge of the sign board should be mounted at least 2' above the existing ground surface to facilitate ease of viewing.
 - II. The posts should be set in a hole at least 4' deep with concrete footings to preclude downing by high winds.
 - III. On the construction site, the sign should be positioned such that nothing obstructs the public's view from the primary street access point.
 - IV. For construction projects that are developed in phases, the sign should be moved to the area that is under active construction.
 - V. In situations where all phases of the construction project are completed on a property prior to expiration of the Dust Control Plan, a written request for cancellation of the Dust Control Plan must be submitted to the Engineer.

3. The sign board shall contain the following information:

- (a) Project Name
- (b) Name of Prime Contractor
- (c) Phone Number of Contractor's Employee Responsible for Dust Control Matters
- (d) County designated phone number (to be provided by the Engineer)
- (e) South Coast Air Quality Management District Phone Number

4. The sign board shall be designed to the following alpha and numeric text dimensions (sign boards written in longhand are unacceptable).

(a) For a permittee subject to the 4' x 4' sign requirement, the District provides the following example: (as modified by the County of Riverside for use on County Public Works projects)

1" UPPERCASE Letters →	PROJECT NAME:		3 ½" Title Case Bold Letters ←
1" UPPERCASE Letters →	CONTRACTOR		3 ½" Title Case Bold Letters ←
1" Title Case Letters →	Contractor's Dust Control Phone #		3" Bold Numbers ←
1" Title Case Letters →	County of Riverside Phone #		3" Bold Numbers ←
1" Title Case Letters →	Phone Number:	SCAQMD 1-800-CUT-SMOG	3 ½" Bold Numbers ←

"Title Case" means the first letter of a word is capitalized and subsequent letters are lower case.

AQMD Recommendations

(b) For a permittee subject to the 4' x 8' sign requirement, the District provides the following example: (as modified by the County of Riverside)

2" UPPERCASE Letters	PROJECT NAME:	4" Title Case Bold Letters
2" UPPERCASE Letters	CONTRACTOR	4" Title Case Bold Letters
2" Title Case Letters	Contractor's Dust Control Phone #	4" Bold Numbers
2" Title Case Letters	County of Riverside Phone #	4" Bold Numbers
2" Title Case Letters	Phone Number:	4 1/2" Bold Numbers
2" Title Case Letters	<p style="text-align: center;">SCAQMD 1-800-CUT-SMOG</p> <p style="text-align: center;">COUNTY OF RIVERSIDE TRANSPORTATION DEPARTMENT</p>	

01/11/2011

AMD Recommendations

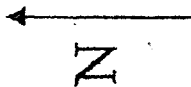

Distance and location of nearest:
 Residence _____
 Business _____

Section 1
Simplified Sample Site Plan

Existing Residential

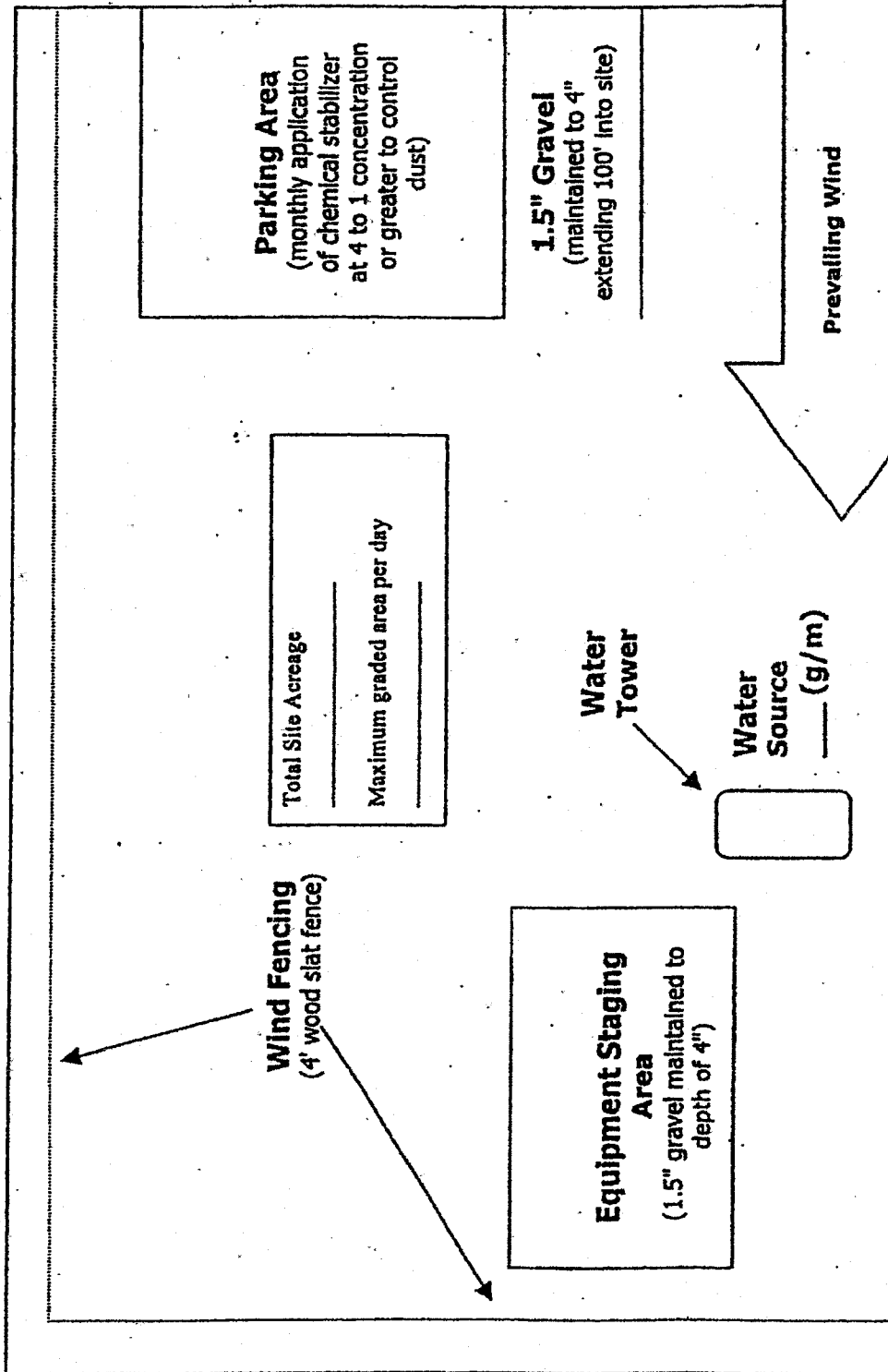

Existing Residential

Site Access

Parking Area
(monthly application
of chemical stabilizer
at 4 to 1 concentration
or greater to control
dust)

1.5" Gravel
(maintained to 4"
extending 100' into site)

Total Site Acreage _____
 Maximum graded area per day _____

Water Tower

Water Source
_____ (g/m)

Wind Fencing
(4' wood slat fence)

Equipment Staging
Area
(1.5" gravel maintained to
depth of 4")

Prevailing Wind

Vacant Land

Existing Residential

Remember...
**DUST CONTROL IS REQUIRED 24 HOURS A DAY, 7 DAYS A WEEK,
 REGARDLESS OF CONSTRUCTION STATUS**

Plan Review Checklist Clearing/Grubbing/Mass Grading Phase

- If feasible, use grading permit conditions to break the project into phases so that only a portion of the site is disturbed at any given time to ensure control of fugitive dust. This technique is critical for project sites with greater than 100 acres.
- Prior to initiating activity, pre-water site through use of portable irrigation lines. At least 72 hours of pre-watering is recommended for each area prior to initiating earth-movement. Require the Applicant to specify water source and available flow rate (g/m).
- Water applied continuously to all disturbed portions of the site by means of water truck/water pull as necessary to maintain sufficient visible moisture on the soil surface. For reference, one 2,000 gallon water truck can treat approximately 4 acres of active construction per hour. Also, for cut and fill activities, one 10,000 gallon water pull is estimated to be necessary for each 7,000 cubic yards of daily earth-movement. Multiple 4,000-gallon water trucks may be used in place of one 10,000-gallon water pull. Touch and visual contrast are reasonably good indicators of soil moisture. Surface areas that are dry to the touch and appear lighter-colored require the application of additional water to prevent visible or fugitive dust. Require the Applicant to specify the number of watering vehicles available for dust control during mass grading and during off-hours as well as availability of back-up water trucks if the site experiences dust control problems.
- Water towers are necessary for projects with more than 10 acres of active construction. Without a water tower, it can take up to 30 minutes to fill a 2,000 gallon water truck. Also, multiple water towers are necessary for projects that use water pulls as filling one 10,000 gallon water pull can drain a water tower which takes up to 40 minutes to refill.
- Wind fencing is necessary between the site and nearby residences or businesses. Off-site upwind fencing and on-site wind fencing for larger projects can also keep blowsand from being deposited onto the site or traveling through the site.
- A perimeter watering system consisting of portable irrigation equipment may be an effective mitigation system to protect surrounding residences and businesses. The portable watering system may be used in place of or in conjunction with watering trucks. The local jurisdiction may also be provided access to this equipment.

Remember...

**DUST CONTROL IS REQUIRED 24 HOURS A DAY, 7 DAYS A WEEK,
REGARDLESS OF CONSTRUCTION STATUS**

- Construction site accesses are to be improved with 1.5" gravel maintained to a depth of 4" , at least 20' wide, and extending 100 feet into the site. If the project site is not balanced, a wheel washing system and/or ribbed steel plates should be placed in the roadway before the vehicle enters the graveled area to clean the tires and prevent trackout.
- Equipment staging areas are to be treated with 1.5" gravel maintained to a depth of 4".
- Employee parking areas are to be covered with 1.5" gravel maintained to a depth of 4" or treated with chemical dust suppressants at a 4 to 1 ratio on at least a monthly basis to prevent fugitive dust.
- Chemical dust suppressants are to be mixed at a ratio of 20 to 1 and applied to all disturbed surfaces that are proposed to remain inactive for a period of at least 10 consecutive days. These products are effective in preventing and controlling dust. Recordkeeping is necessary to demonstrate compliance.
- All project sites greater than 100 acres shall monitor daily wind speeds and AQMD forecasted wind events (call 1.800.CUT.SMOG; press one for air quality information, and then press five for Coachella Valley wind forecasts). Operators shall maintain these records for review by any local code enforcement officer or AQMD inspector.
- An environmental observer whose primary duty is to oversee dust control at the site is to be used for construction projects greater than 100 acres and/or sites with more than 50 acres of active construction. The environmental observer is tasked with monitoring dust abatement measures and authorized to deploy additional water trucks and other dust control actions (i.e., wind fencing, street sweepers, chemical dust suppressants, etc.) as necessary to prevent or control fugitive dust.
- Other (specify): _____

Remember...
DUST CONTROL IS REQUIRED 24 HOURS A DAY, 7 DAYS A WEEK,
REGARDLESS OF CONSTRUCTION STATUS

**Plan Review Checklist
Finish Grading Phase**

- Water applied continuously to all disturbed portions of the site by means of water truck/water pull as necessary to maintain sufficient visible moisture on the soil surface. For reference, one 2,000 gallon water truck can treat approximately 4 acres of active construction per hour. Also, for cut and fill activities, one 10,000 gallon water pull is estimated to be necessary for each 7,000 cubic yards of daily earth-movement. Multiple 4,000-gallon water trucks may be used in place of a 10,000-gallon water pull. Touch and visual contrast are reasonably good indicators of soil moisture. Surface areas that are dry to the touch and appear lighter-colored require the application of additional water to prevent visible or fugitive dust. Require the Applicant to specify the number of watering vehicles available for dust control during finish grading and during off-hours as well as availability of back-up water trucks if the site experiences dust control problems.
- Water towers are necessary for projects with more than 10 acres of active construction. Without a water tower, it can take up to 30 minutes to fill a 2,000 gallon water truck. Also, multiple water towers are necessary for projects that use water pulls as filling one 10,000 gallon water pull can drain a water tower which takes up to 40 minutes to refill.
- Wind fencing is necessary between the site and nearby residences or businesses to reduce fugitive dust. Off-site upwind fencing and on-site wind fencing for larger projects can also keep blowsand from being deposited onto the site or traveling through a site.
- Chemical dust suppressants are to be applied at a concentration of at least 10 to 1 to finish graded areas once final elevations have been reached. For areas that will remain inactive for longer periods, vegetation can be a cost-effective alternative to chemical stabilization. Wind fencing or other obstructions can keep the stabilized area free from future disturbances.
- Construction site access(es) are to be improved with 1.5" gravel maintained to a depth of at least 4" with a minimum width of at least 20', extending 100 feet into the project site.
- Equipment staging areas are to be treated with 1.5" gravel maintained to a depth of 4".
- Internal roadway networks are to be treated with chemical dust suppressants at a minimum rate of at least 4 to 1 and retreated on a monthly basis once final roadway elevations have been reached.
- Employee parking areas are to be treated with chemical dust suppressants at a mix ratio of at least 4 to 1 and retreated on at least a monthly basis or covered with 1.5" gravel maintained to a depth of 4" to prevent fugitive dust.
- Other (specify): _____

**Remember...
DUST CONTROL IS REQUIRED 24 HOURS A DAY, 7 DAYS A WEEK,
REGARDLESS OF CONSTRUCTION STATUS**

**Plan Review Checklist
Construction Phase**

Water applied continuously to all disturbed portions of the site by means of water truck/water pull is necessary to maintain sufficient visible moisture on the soil surface. For reference, one 2,000 gallon water truck can treat approximately 4 acres of active construction per hour. Touch and visual contrast are reasonably good indicators of soil moisture. Surface areas that are dry to the touch and appear lighter-colored require the application of additional water to prevent visible or fugitive dust. Require the Applicant to specify the number of watering vehicles available for dust control during the construction phase and during off-hours as well as availability of back-up water trucks if the site experiences dust control problems.

Wind fencing is necessary between the site and nearby residences or businesses. Off-site upwind fencing and on-site wind fencing for larger projects can also keep blowsand from being deposited onto the site or traveling through the site. Block walls, if part of the final project, can replace wind fencing during the construction phase.

Chemical dust suppressants are to be applied at a concentration of at least 20 to 1 to finish graded areas once final elevations have been reached. For areas that will remain inactive for longer periods, vegetation can be a cost-effective alternative to chemical stabilization. Wind fencing or other obstructions can keep the stabilized area free from future disturbances.

Construction site accesses are to be improved with 1.5" gravel, maintained to a depth of 4", with a width of at least 20', extending 100' into the project site. Paving internal roadways can substitute for gravel.

Internal roadway networks are to be paved as early as feasible in the construction phase. Street sweeping of internal and/or external access roads will likely be required to control entrained road dust.

Employee parking areas are to be treated with chemical dust suppressants at a mix ratio of no less than 4 to 1 and retreated on a monthly basis, or more frequently if fugitive dust is observed. If internal roadway is complete, employees are to be instructed to park on paved roads.

Other (specify): _____

**Remember...
DUST CONTROL IS REQUIRED 24 HOURS A DAY, 7 DAYS A WEEK,
REGARDLESS OF CONSTRUCTION STATUS**

RULE 403 IMPLEMENTATION HANDBOOK

REASONABLY AVAILABLE CONTROL MEASURES

Paragraph (d)(3) of Rule 403 allows activities outside the South Coast Air Basin (see Figure 2-1) to implement reasonably available control measures in lieu of best available control measures. Additionally, as specified by subparagraph (f)(3)(D) of Rule 403, any person seeking approval of a fugitive dust emissions control plan for projects outside the South Coast Air Basin must demonstrate to the satisfaction of the District that the given activity is employing all reasonably available fugitive dust control measures.

The District has prepared the attached listing of reasonably available fugitive dust control measures for a variety of source categories. This list is based on the U.S. Environmental Protection Agency's reference document entitled, "Control of Open Fugitive Dust Sources," Midwest Research Institute, September 1988.

The District encourages the use of those dust control measures that minimize the use of potable water. When water is needed, reclaimed water should be utilized to the greatest extent feasible.

RULE 403 IMPLEMENTATION HANDBOOK

REASONABLY AVAILABLE CONTROL MEASURES

The left column contains a listing of the sources of fugitive dust which are intended for emission control under District Rule 403 and a listing of control measures and high-wind measures. The right column contains a description of the reasonably available fugitive dust control measures for each of the sources.

Source: (1) Land Clearing/Earth-Moving

CONTROL MEASURES

(A) Watering

DESCRIPTION

- (1) Application of water by means of trucks, hoses and/or sprinklers prior to conducting any land clearing. This will increase the moisture content of the soils; thereby increasing its stability.
- (2) Pre-application of water to depths of proposed cuts.
- (3) Once the land clearing/earth moving activities are complete, a second application of water can generate a thin crust that stabilizes the disturbed surface area provided that it is not disturbed. (Security fencing can be used to prevent unwanted future disturbances of sites where a surface crust has been created).

(B) Chemical stabilizers

- (1) Only effective in areas which are not subject to daily disturbances.
- (2) Vendors can supply information on product application and required concentrations to meet the specifications established by the Rule.

(C) Wind fencing

- (1) Three- to five-foot barriers with 50% or less porosity located adjacent to roadways or urban areas can be effective in reducing the amount of windblown material leaving a site.
- (2) Would likely be used in conjunction with other measures (e.g., watering, chemical stabilization, etc.) to ensure that visible emissions do not cross a property line.

(D) Cover haul vehicles

- (1) Entire surface area of hauled earth should be covered once vehicle is full.

(E) Bedliners in haul vehicles

- (1) When feasible, use in bottom-dumping haul vehicles.

HIGH WIND MEASURE

- (a) Cease all active operations; or
- (b) Apply water within 15 minutes to any soil surface which is being moved or otherwise disturbed.

Source: (2) Unpaved Roads

CONTROL MEASURES

DESCRIPTION

- (F) Paving
 - (1) Requires street sweeping/cleaning if subject to material accumulation.
- (G) Chemical stabilization
 - (1) Vendors can supply information as to application methods and concentrations to meet the specifications established by the Rule
 - (2) Not recommended for high volume or heavy equipment traffic use.
- (H) Watering
 - (1) In sufficient quantities to keep surface moist.
 - (2) Required application frequency will vary according to soil type, weather conditions, and vehicular use.
- (I) Reduce speed limits
 - (1) 15 mile per hour maximum. May need to be used in conjunction with watering or chemical stabilization to prevent visible emissions from crossing the property line.
- (J) Reduce vehicular trips
 - (1) Access restriction or redirecting traffic to reduce vehicle trips by a minimum of 60 percent.
- (K) Gravel
 - (1) Gravel maintained to a depth of four inches can be an effective measure.
 - (2) Should only be used in areas where paving, chemical stabilization or frequent watering is not feasible.

HIGH WIND MEASURE

- (c) Apply a chemical stabilizer (to meet the specifications established by the Rule) prior to wind events; or
- (d) Apply water once each hour; or
- (e) Stop all vehicular traffic.

RULE 403 IMPLEMENTATION HANDBOOK

Source: (3) Storage Piles

CONTROL MEASURES

DESCRIPTION

- (L) Wind sheltering
 - (1) Enclose in silos.
 - (2) Install three-sided barriers equal to height of material, with no more than 50 percent porosity.
- (M) Watering
 - (1) Application methods include: spray bars, hoses and water trucks.
 - (2) Frequency of application will vary on site-specific conditions.
- (N) Chemical stabilizers
 - (1) Best for use on storage piles subject to infrequent disturbances.
- (O) Altering load-in/load-out procedures
 - (1) Confine load-in/load-out procedures to leeward (downwind) side of the material.
 - (2) May need to be used in conjunction with wind sheltering to prevent visible emissions from crossing the property line.
- (P) Coverings
 - (1) Tarps, plastic, or other material can be used as a temporary covering.
 - (2) When used, these should be anchored to prevent wind from removing coverings.

HIGH WIND MEASURE

- (f) Apply chemical stabilizers (to meet the specifications established by the Rule) prior to wind events; or
- (g) Apply water once per hour; or
- (h) Install temporary covers.

Source: (4) Paved Road Track-Out

CONTROL MEASURES

DESCRIPTION

- | | |
|--------------------------------|--|
| (Q) Chemical stabilization | (1) Most effective when used on areas where active operations have ceased.
(2) Vendors can supply information on methods for application and required concentrations. |
| (R) Sweep/clean roadways | (1) Either sweeping or water flushing may be used. |
| (S) Cover haul vehicles | (1) Entire surface area should be covered once vehicle is full. |
| (T) Bedliners in haul vehicles | (1) When feasible, use in bottom dumping vehicles. |
| (U) Site access improvement | (1) Pave internal roadway system.
(2) Most important segment, last 100 yards from the connection with paved public roads |

HIGH WIND MEASURE

- (i) Cover all haul vehicles; and
- (j) Clean streets with water flushing, unless prohibited by the Regional Water Quality Control Board.

RULE 403 IMPLEMENTATION HANDBOOK

Source: (5) Disturbed Surface Areas/ Inactive Construction Sites

CONTROL MEASURES

DESCRIPTION

- (Q) Chemical stabilization
 - (1) Most effective when used on areas where active operations have ceased.
 - (2) Vendors can supply information on methods for application and required concentrations.
- (R) Watering
 - (1) Requires frequent applications unless a surface crust can be developed.
- (S) Wind fencing
 - (1) Three- to five-foot barriers with 50% or less porosity adjacent to roadways or urban areas can be effective in reducing the amount of wind blown material leaving a site.
- (T) Vegetation
 - (1) Establish as quickly as possible when active operations have ceased.
 - (2) Use of drought tolerant, native vegetation is encouraged.

HIGH WIND MEASURES

- (k) Apply chemical stabilizers (to meet the specifications established by the Rule); or
- (l) Apply water to all disturbed surface areas 3 times per day.

RULE 403 IMPLEMENTATION HANDBOOK

BEST AVAILABLE CONTROL MEASURES

Rule 403, paragraph (d)(2) requires active operations [defined in Rule 403, paragraph (c)(1)] within the South Coast Air Basin (see Figure 2-1) to implement at least one best available control measure for each fugitive dust source type on site. Additionally, as specified by subparagraph (f)(3)(D) of Rule 403, any person seeking approval of a fugitive dust emissions control plan for projects within the South Coast Air Basin must demonstrate to the satisfaction of the AQMD that the given activity is employing all best available fugitive dust control measures.

The AQMD has prepared the attached listing of best available fugitive dust control measures for a variety of source categories. This list is based on the U.S. Environmental Protection Agency's reference document entitled, "Fugitive Dust Background Document and Technical Information Document for Best Available Control Measures," Office of Air and Radiation, September 1992.

The AQMD encourages the use of those dust control measures that minimize the use of potable water. When water is needed, reclaimed water should be utilized to the greatest extent feasible.

RULE 403 IMPLEMENTATION HANDBOOK

BEST AVAILABLE CONTROL MEASURES

The left column contains a listing of the sources of fugitive dust which are intended for emission control under District Rule 403 and a listing of control measures and high-wind measures. The right column contains a description of the best available fugitive dust control measures for each of the sources.

Source: (1) Land Clearing/Earth-Moving

CONTROL MEASURES

DESCRIPTION

- | | |
|--------------------------------|---|
| (A) Watering (pre-grading) | (1) Application of water by means of trucks, hoses and/or sprinklers prior to conducting any land clearing. This will increase the moisture content of the soils; thereby increasing its stability. |
| | (2) Pre-application of water to depths of proposed cuts. |
| (A-1) Watering (post-grading) | (1) In active earth-moving areas water should be applied at sufficient frequency and quantity to prevent visible emissions from extending more than 100 feet from the point of origin. |
| (A-2) Pre-grading planning | (1) Grade each phase separately, timed to coincide with construction phase; or |
| | (2) Grade entire project, but apply chemical stabilizers or ground cover to graded areas where construction phase begins more than 60 days after grading phase ends. |
| (B) Chemical stabilizers | (1) Only effective in areas which are not subject to daily disturbances. |
| | (2) Vendors can supply information on product application and required concentrations to meet the specifications established by the Rule. |
| (C) Wind fencing | (1) Three- to five-foot barriers with 50% or less porosity located adjacent to roadways or urban areas can be effective in reducing the amount of windblown material leaving a site. Must be implemented in conjunction with either measure (A-1) or (B). |
| (D) Cover haul vehicles | (1) Entire surface area of hauled earth should be covered once vehicle is full. |
| (E) Bedliners in haul vehicles | (1) When feasible, use in bottom-dumping haul vehicles. |

HIGH WIND MEASURE

- (a) Cease all active operations; or
 (b) Apply water within 15 minutes to any soil surface which is being moved or otherwise disturbed.

RULE 403 IMPLEMENTATION HANDBOOK

Source: (2) Unpaved Roads

CONTROL MEASURES

DESCRIPTION

- | | |
|----------------------------|---|
| (F) Paving | (1) Requires street sweeping/cleaning if subject to material accumulation. |
| (G) Chemical stabilization | (1) Vendors can supply information as to application methods and concentrations to meet the specifications established by the Rule
(2) Not recommended for high volume or heavy equipment traffic use. |
| (H) Watering | (1) In sufficient quantities to keep surface moist.
(2) Required application frequency will vary according to soil type, weather conditions, and vehicular use. |
| (I) Reduce speed limits | (1) 15 mile per hour maximum. May need to be used in conjunction with watering or chemical stabilization to prevent visible emissions from crossing the property line. |
| (J) Reduce vehicular trips | (1) Access restriction or redirecting traffic to reduce vehicle trips by a minimum of 60 percent. |
| (K) Gravel | (1) Gravel maintained to a depth of four inches can be an effective measure.
(2) Should only be used in areas where paving, chemical stabilization or frequent watering is not feasible. |

HIGH WIND MEASURE

- (a) Apply a chemical stabilizer (to meet the specifications established by the Rule) prior to wind events; or
- (b) Apply water once each hour; or
- (c) Stop all vehicular traffic.

RULE 403 IMPLEMENTATION HANDBOOK

Source: (3) Storage Piles

CONTROL MEASURES

DESCRIPTION

- | | |
|--|--|
| (L) Wind sheltering | (1) Enclose in silos.
(2) Install three-sided barriers equal to height of material, with no more than 50 percent porosity. |
| (M) Watering | (1) Application methods include: spray bars, hoses and water trucks.
(2) Frequency of application will vary on site-specific conditions. |
| (N) Chemical stabilizers | (1) Best for use on storage piles subject to infrequent disturbances. |
| (O) Altering load-in/load-out procedures | (1) Confine load-in/load-out procedures to leeward (downwind) side of the material.
Must be used in conjunction with either measure (L), (M), (N), or (P). |
| (P) Coverings | (1) Tarps, plastic, or other material can be used as a temporary covering.
(2) When used, these should be anchored to prevent wind from removing coverings. |

HIGH WIND MEASURE

- (a) Apply chemical stabilizers (to meet the specifications established by the Rule) prior to wind events; or
(b) Apply water once per hour; or
(c) Install temporary covers.

RULE 403 IMPLEMENTATION HANDBOOK

Source: (4) Paved Road Track-Out

CONTROL MEASURES

DESCRIPTION

Compliance with District Rule 403.

Paragraph (d)(5).

January 1999

RULE 403 IMPLEMENTATION HANDBOOK

Source: (S) Disturbed Surface Areas/ Inactive Construction Sites

CONTROL MEASURES

DESCRIPTION

- (Q) Chemical stabilization
 - (1) Most effective when used on areas where active operations have ceased.
 - (2) Vendors can supply information on methods for application and required concentrations.
- (R) Watering
 - (1) Requires frequent applications unless a surface crust can be developed.
- (S) Wind fencing
 - (1) Three- to five-foot barriers with 50% or less porosity adjacent to roadways or urban areas can be effective in reducing the amount of wind blown material leaving a site. Must be used in conjunction with either measure (Q), (R), or (T).
- (T) Vegetation
 - (1) Establish as quickly as possible when active operations have ceased.

HIGH WIND MEASURES

- (a) Apply chemical stabilizers (to meet the specifications established by the Rule); or
- (b) Apply water to all disturbed surface areas 3 times per day.

* Use of drought tolerant, native vegetation is encouraged.

TABLE 1

BEST [REASONABLY]* AVAILABLE CONTROL MEASURES FOR HIGH WIND CONDITIONS

FUGITIVE DUST SOURCE CATEGORY	<u>CONTROL MEASURES</u>
Earth-moving	(1A) Cease all active operations; OR (2A) Apply water to soil not more than 15 minutes prior to moving such soil.
Disturbed surface areas	(0B) On the last day of active operations prior to a weekend, holiday, or any other period when active operations will not occur for not more than four consecutive days: apply water with a mixture of chemical stabilizer diluted to not less than 1/20 of the concentration required to maintain a stabilized surface for a period of six months; OR (1B) Apply chemical stabilizers prior to wind event; OR (2B) Apply water to all unstabilized disturbed areas 3 times per day. If there is any evidence of wind driven fugitive dust, watering frequency is increased to a minimum of four times per day; OR (3B) Take the actions specified in Table 2, Item (3c); OR (4B) Utilize any combination of control actions (1B), (2B), and (3B) such that, in total, these actions apply to all disturbed surface areas.
Unpaved roads	(1C) Apply chemical stabilizers prior to wind event; OR (2C) Apply water twice [once] per hour during active operation; OR (3C) Stop all vehicular traffic.
Open storage piles	(1D) Apply water twice [once] per hour; OR (2D) Install temporary coverings.
Paved road track-out	(1E) Cover all haul vehicles; OR (2E) Comply with the vehicle freeboard requirements of Section 23114 of the California Vehicle Code for both public and private roads.
All Categories	(1F) Any other control measures approved by the Executive Officer and the U.S. EPA as equivalent to the methods specified in Table 1 may be used.

* Measures in [brackets] are reasonably available control measures and only apply to sources not within the South Coast Air Basin.

TABLE 2
DUST CONTROL ACTIONS FOR EXEMPTION FROM PARAGRAPH (d)(4)*

<u>FUGITIVE DUST SOURCE CATEGORY</u>	<u>CONTROL ACTIONS</u>
Earth-moving (except construction cutting and filling areas, and mining operations)	<p>(1a) Maintain soil moisture content at a minimum of 12 percent, as determined by ASTM method D-2216, or other equivalent method approved by the Executive Officer, the California Air Resources Board, and the U.S. EPA. Two soil moisture evaluations must be conducted during the first three hours of active operations during a calendar day, and two such evaluations each subsequent four-hour period of active operations; OR</p> <p>(1a-1) For any earth-moving which is more than 100 feet from all property lines, conduct watering as necessary to prevent visible dust emissions from exceeding 100 feet in length in any direction.</p>
Earth-moving: Construction fill areas:	<p>(1b) Maintain soil moisture content at a minimum of 12 percent, as determined by ASTM method D-2216, or other equivalent method approved by the Executive Officer, the California Air Resources Board, and the U.S. EPA. For areas which have an optimum moisture content for compaction of less than 12 percent, as determined by ASTM Method 1557 or other equivalent method approved by the Executive Officer and the California Air Resources Board and the U.S. EPA, complete the compaction process as expeditiously as possible after achieving at least 70 percent of the optimum soil moisture content. Two soil moisture evaluations must be conducted during the first three hours of active operations during a calendar day, and two such evaluations during each subsequent four-hour period of active operations.</p>

* Measures in [brackets] are reasonably available control measures and only apply to sources not within the South Coast Air Basin.

TABLE 2 (Continued)

FUGITIVE DUST SOURCE CATEGORY	CONTROL ACTIONS
Earth-moving: Construction cut areas and mining operations:	(1c) Conduct watering as necessary to prevent visible emissions from extending more than 100 feet beyond the active cut or mining area unless the area is inaccessible to watering vehicles due to slope conditions or other safety factors.
Disturbed surface areas (except completed grading areas)	(2a/b) Apply dust suppression in sufficient quantity and frequency to maintain a stabilized surface. Any areas which cannot be stabilized, as evidenced by wind driven fugitive dust must have an application of water at least twice per day to at least 80 [70] percent of the unstabilized area.
Disturbed surface areas: Completed grading areas	(2c) Apply chemical stabilizers within five working days of grading completion; OR (2d) Take actions (3a) or (3c) specified for inactive disturbed surface areas.
Inactive disturbed surface areas	(3a) Apply water to at least 80 [70] percent of all inactive disturbed surface areas on a daily basis when there is evidence of wind driven fugitive dust, excluding any areas which are inaccessible to watering vehicles due to excessive slope or other safety conditions; OR (3b) Apply dust suppressants in sufficient quantity and frequency to maintain a stabilized surface; OR (3c) Establish a vegetative ground cover within 21 [30] days after active operations have ceased. Ground cover must be of sufficient density to expose less than 30 percent of unstabilized ground within 90 days of planting, and at all times thereafter; OR (3d) Utilize any combination of control actions (3a), (3b), and (3c) such that, in total, these actions apply to all inactive disturbed surface areas.

* Measures in [brackets] are reasonably available control measures and only apply to sources not within the South Coast Air Basin.

TABLE 2 (Continued)*

<u>FUGITIVE DUST SOURCE CATEGORY</u>	<u>CONTROL ACTIONS</u>
Unpaved Roads	(4a) Water all roads used for any vehicular traffic at least once per every two hours of active operations [3 times per normal 8 hour work day]; OR (4b) Water all roads used for any vehicular traffic once daily and restrict vehicle speeds to 15 miles per hour; OR (4c) Apply a chemical stabilizer to all unpaved road surfaces in sufficient quantity and frequency to maintain a stabilized surface.
Open storage piles	(5a) Apply chemical stabilizers; OR (5b) Apply water to at least 80 [70] percent of the surface area of all open storage piles on a daily basis when there is evidence of wind driven fugitive dust; OR (5c) Install temporary coverings; OR (5d) Install a three-sided enclosure with walls with no more than 50 percent porosity which extend, at a minimum, to the top of the pile.
<u>All Categories</u>	(6a) Any other control measures approved by the Executive Officer and the U.S. EPA as equivalent to the methods specified in Table 2 may be used.

* Measures in [brackets] are reasonably available control measures and only apply to sources not within the South Coast Air Basin.

January 1999

AQMD Recommendations
TABLE 3
TRACK-OUT CONTROL OPTIONS
PARAGRAPH (d)(5)(B)

CONTROL OPTIONS

(1)	Pave or apply chemical stabilization at sufficient concentration and frequency to maintain a stabilized surface starting from the point of intersection with the public paved surface, and extending for a centerline distance of at least 100 feet and a width of at least 20 feet.
(2)	Pave from the point of intersection with the public paved road surface, and extending for a centerline distance of at least 25 feet and a width of at least 20 feet, and install a track-out control device immediately adjacent to the paved surface such that exiting vehicles do not travel on any unpaved road surface after passing through the track-out control device.
(3)	Any other control measures approved by the Executive Officer and the U.S. EPA as equivalent to the methods specified in Table 3 may be used.

Appendix B

Reference Drawings

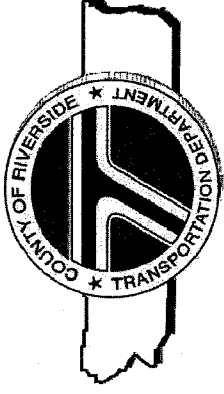
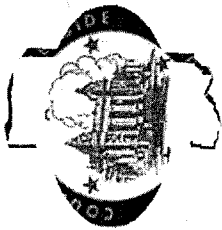

Supervisor John J. Benoit
Riverside County Transportation Department

Avenida Florencita Sidewalk Project

Funded by
Voters Approved Measure A
and
Local Transportation Funds

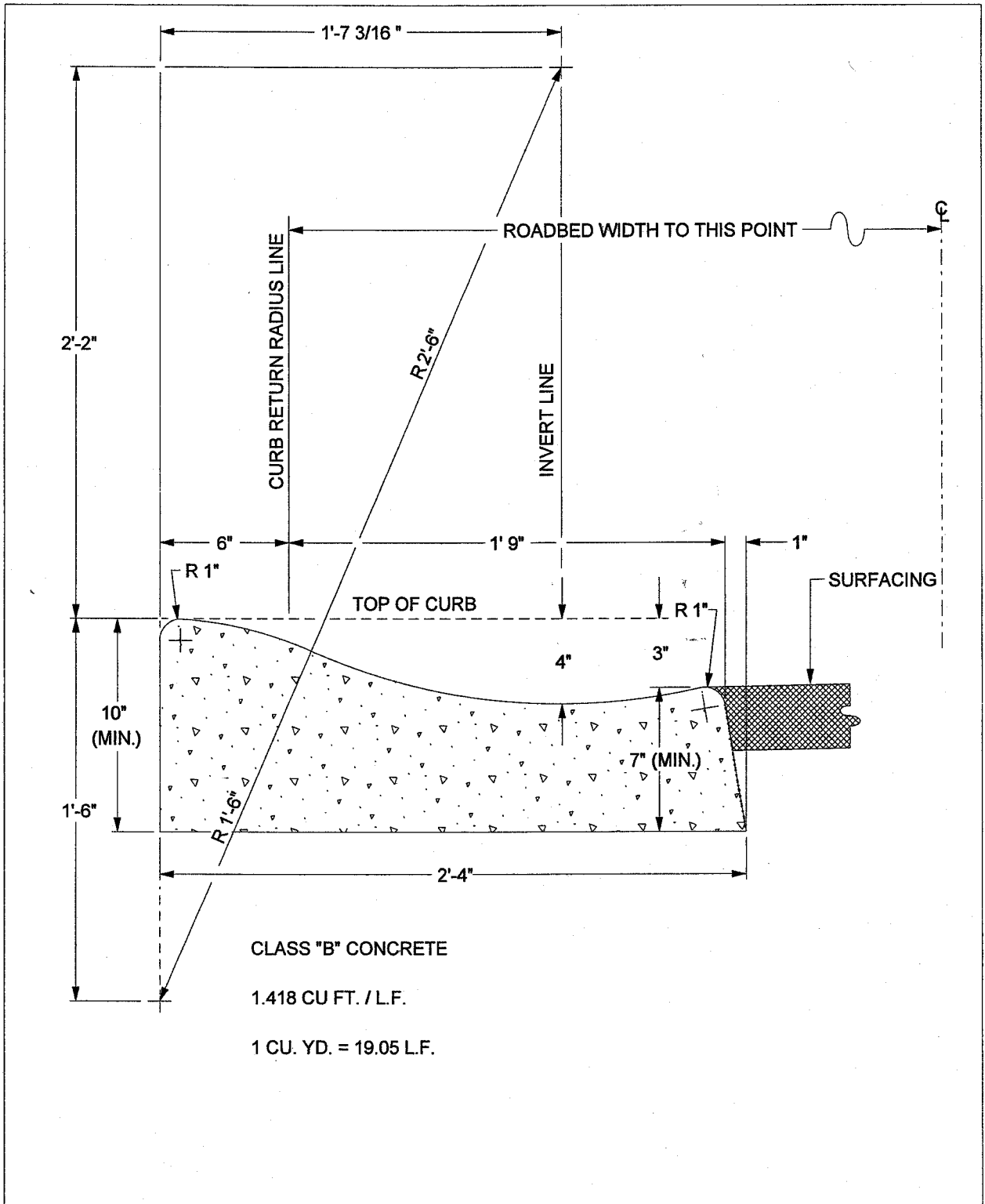

APPROVED BY:

George A. Johnson

DATE: 05/01/07

DIRECTOR OF TRANSPORTATION
 GEORGE A. JOHNSON, RCE 42328

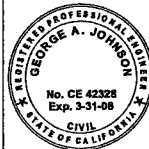

COUNTY OF RIVERSIDE

TYPE "C" CURB

REVISIONS		REV.	BY:	APR'D	DATE	REV.	BY:	APR'D	DATE
2-71, 3-82		1				4			
2-90, 11-04		2				5			
		3				6			

STANDARD NO. 202

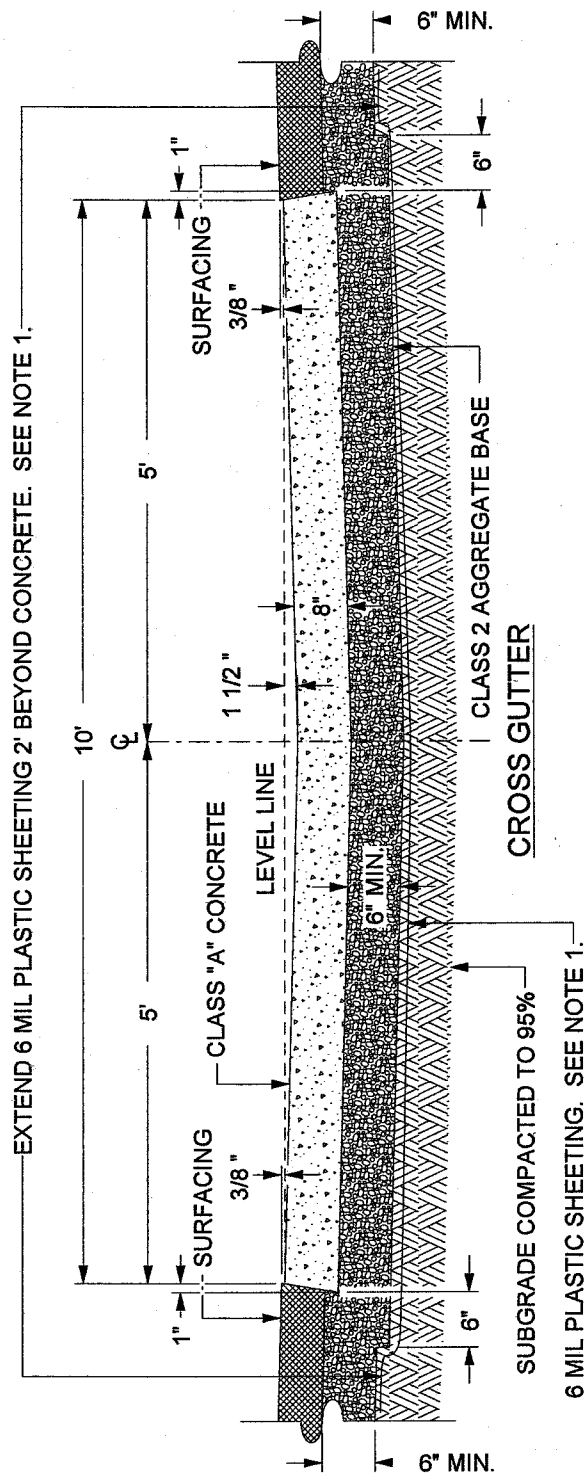

NOT TO SCALE

NOTE
 1. WHEN ABUTTING SOIL HAS A HIGH SULFATE CONTENT, SPECIAL CONSIDERATIONS ARE REQUIRED. SEE SPECIFICATIONS (SECTION 16.04).

APPROVED BY:
George A. Johnson
 DIRECTOR OF TRANSPORTATION
 GEORGE A. JOHNSON, RCE 42328

DATE: 05/01/07

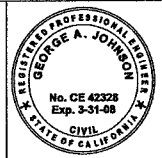

COUNTY OF RIVERSIDE

**CROSS GUTTER
 (TYPICAL SECTION)**

REVISIONS		REV.	BY:	APR'D	DATE	REV.	BY:	APR'D	DATE
8-71, 9-88		1				4			
2-90, 12-97		2				5			
11-04		3				6			

STANDARD NO. 209 (2 OF 2)

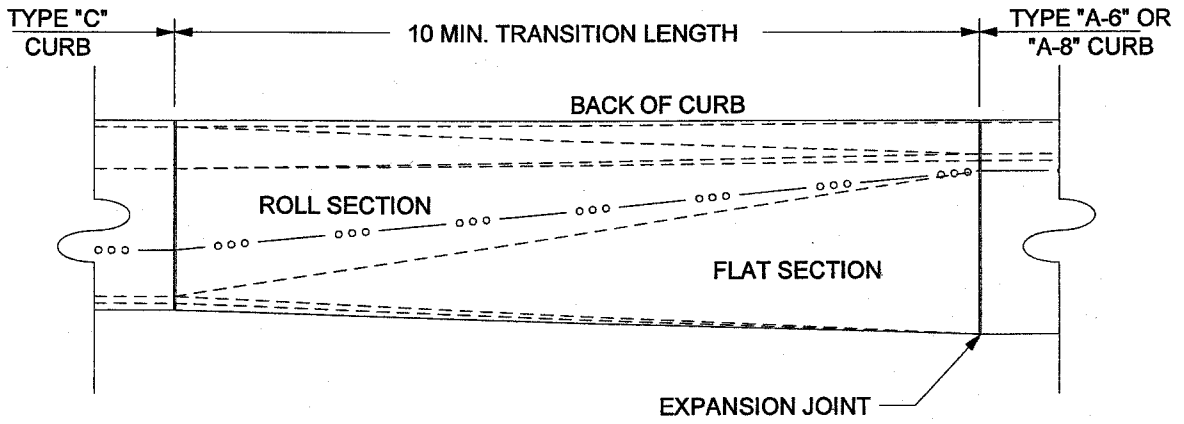

PLAN VIEW

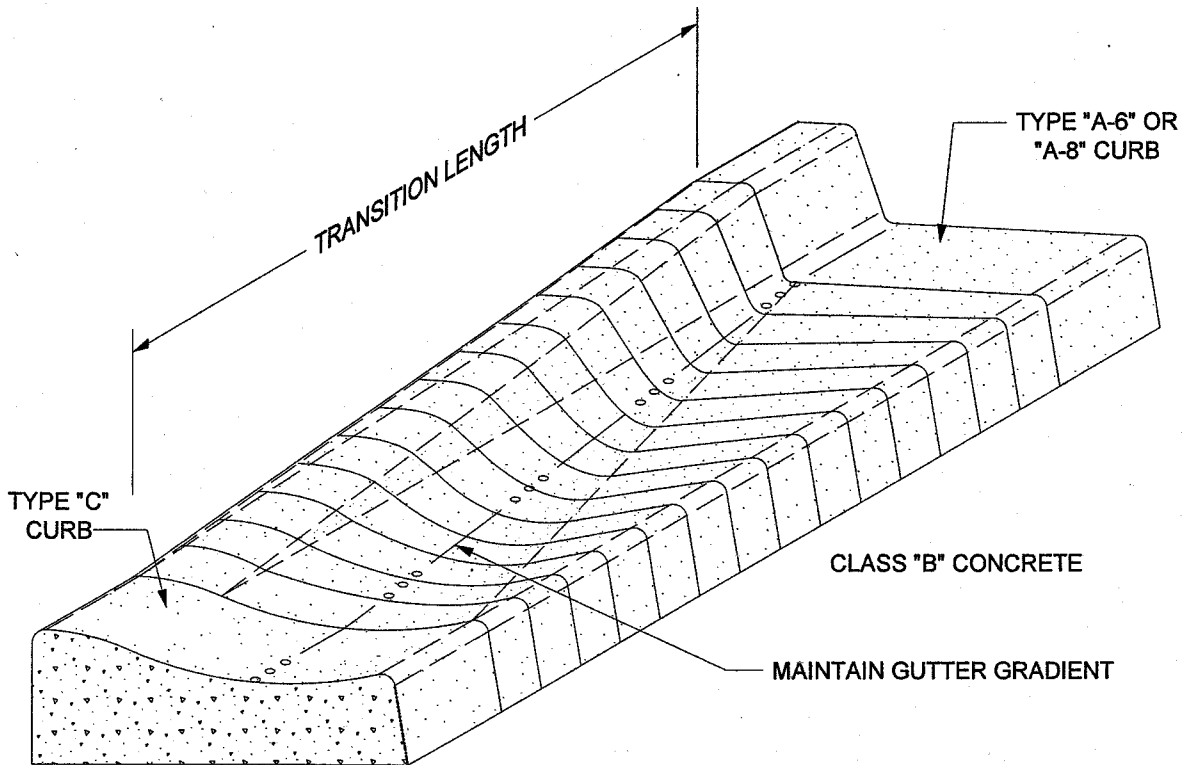

ISOMETRIC VIEW

NOT TO SCALE

APPROVED BY:

George A. Johnson
 DIRECTOR OF TRANSPORTATION
 GEORGE A. JOHNSON, RCE 42328

DATE: 05/01/07

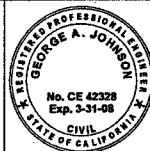

COUNTY OF RIVERSIDE

CURB TRANSITION

STANDARD NO. 211

REVISIONS	REV.	BY:	APR'D	DATE	REV.	BY:	APR'D	DATE
8-24-71, 6-82	1				4			
	2				5			
	3				6			

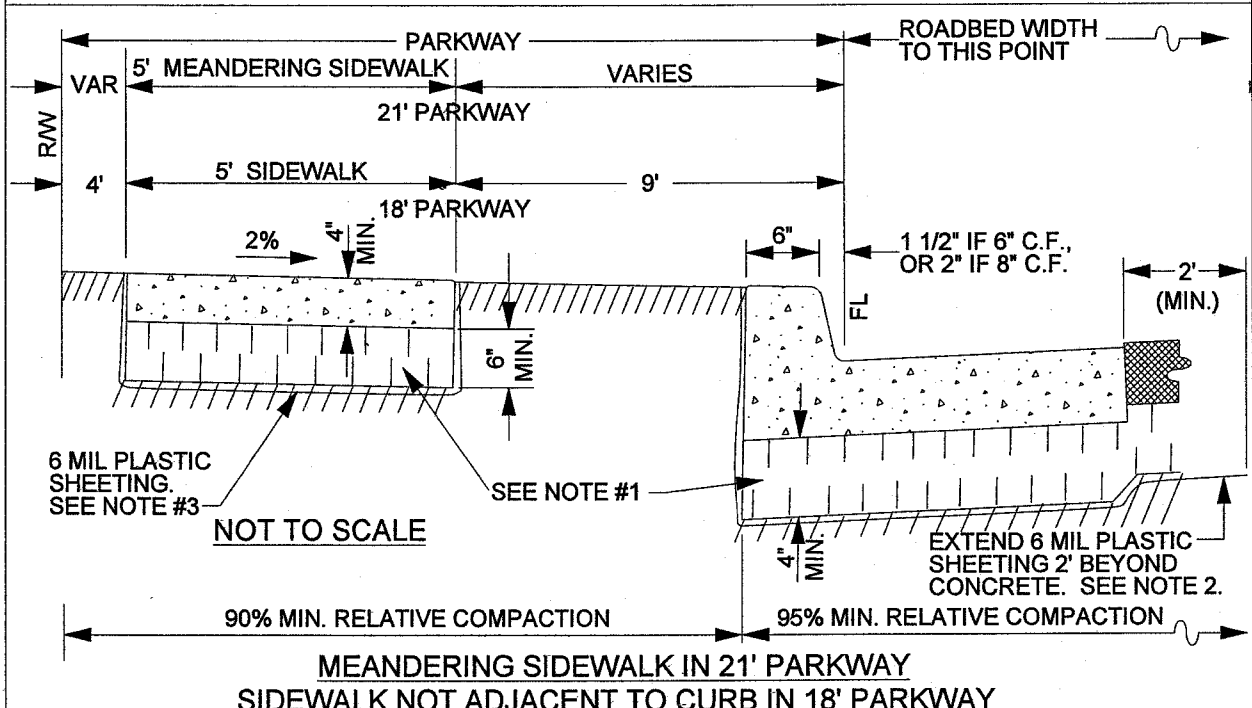
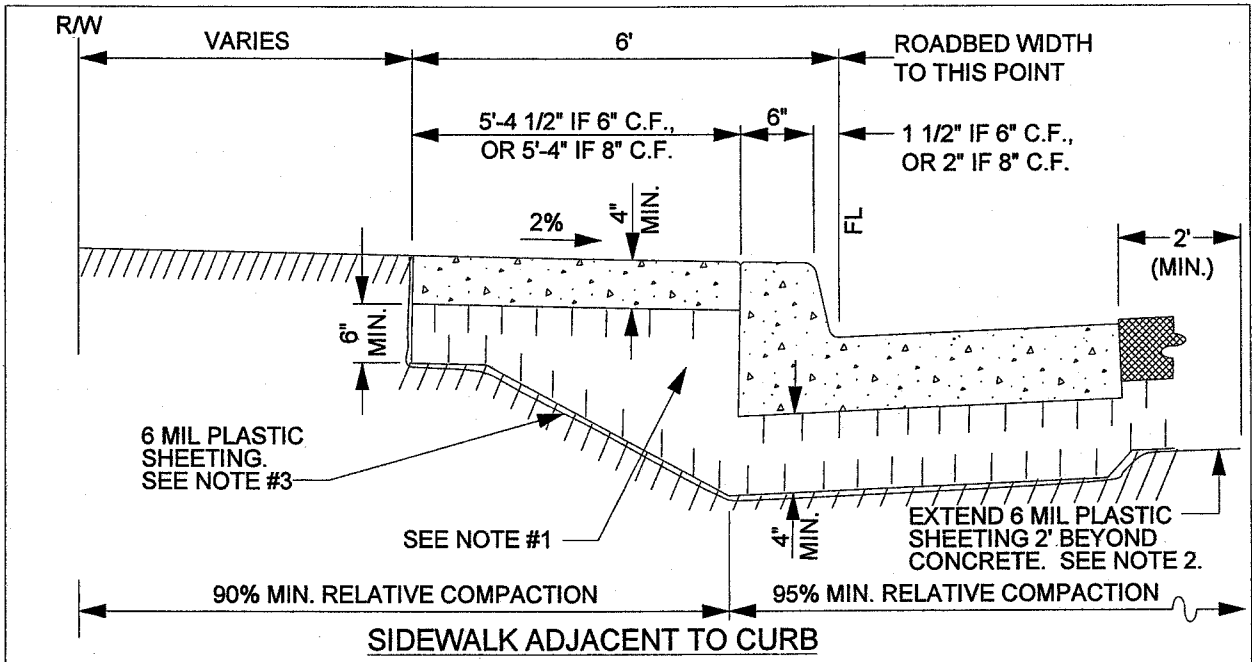

NOTE:

1. AGGREGATE BASE OR APPROVED SELECT MATERIAL WHEN SOILS REPORT INDICATES PRESENCE OF EXPANSIVE SOIL CONDITIONS.
2. ALL CONSTRUCTION SHALL BE CLASS "B" CONCRETE.
3. WHEN ABUTTING SOIL HAS A HIGH SULFATE CONTENT, SPECIAL CONSIDERATIONS ARE REQUIRED. SEE SPECIFICATIONS (SECTION 16.04).

APPROVED BY:				COUNTY OF RIVERSIDE						
				SIDEWALK AND CURB						
DATE: 05/01/07				STANDARD NO. 401						
DIRECTOR OF TRANSPORTATION GEORGE A. JOHNSON, RCE 42328										
REVISIONS			REV.	BY:	APR'D	DATE	REV.	BY:	APR'D	DATE
8-71, 11-77			1				4			
8-82, 9-88			2				5			
4-90, 11-04			3				6			

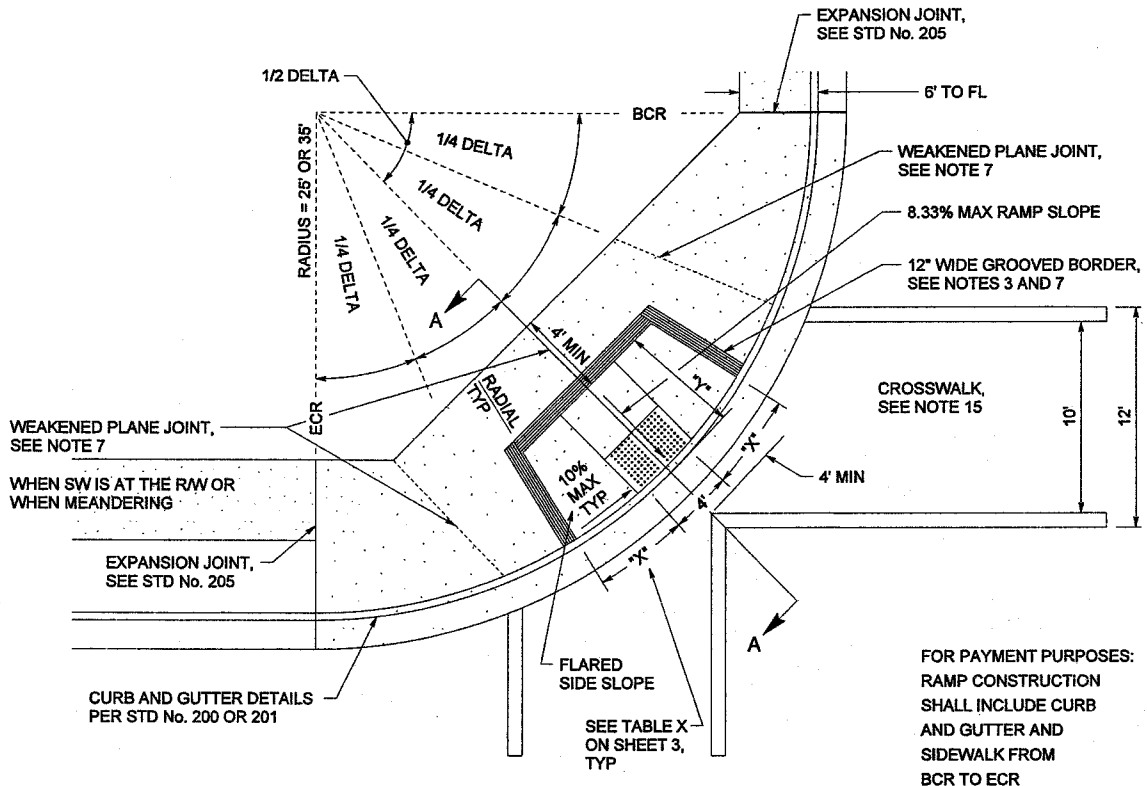

FOR PAYMENT PURPOSES:
RAMP CONSTRUCTION
SHALL INCLUDE CURB
AND GUTTER AND
SIDEWALK FROM
BCR TO ECR

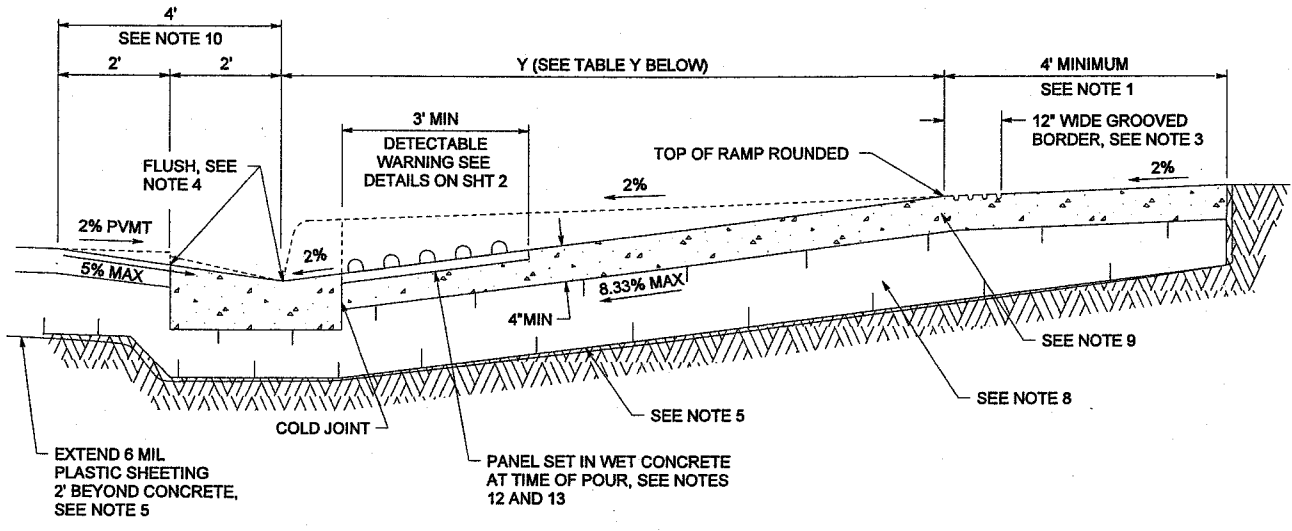

SECTION A-A

TABLE Y

CF	Y
6"	7.90'
8"	10.53'

$$Y = \frac{\text{CURB FACE (FT)}}{6.33\%}$$

FOR NOTES SEE SHEET 7 OF 7
SEE NOTE 16 FOR CONSTRUCTION TOLERANCES

APPROVED BY: _____
DATE: 11/15/04
DIRECTOR OF TRANSPORTATION
JUAN C. PEREZ, RCE 49568



COUNTY OF RIVERSIDE
**CURB RAMP
CASE A**

REVISIONS	REV	BY:	APR'D	DATE	REV	BY:	APR'D	DATE
8-77, 5-80	11-04	1	JK	JP	08-05-10			
10-81, 6-82		2						
9-88, 2-90		3						

NO SCALE
STANDARD No. 403 (1 OF 7)

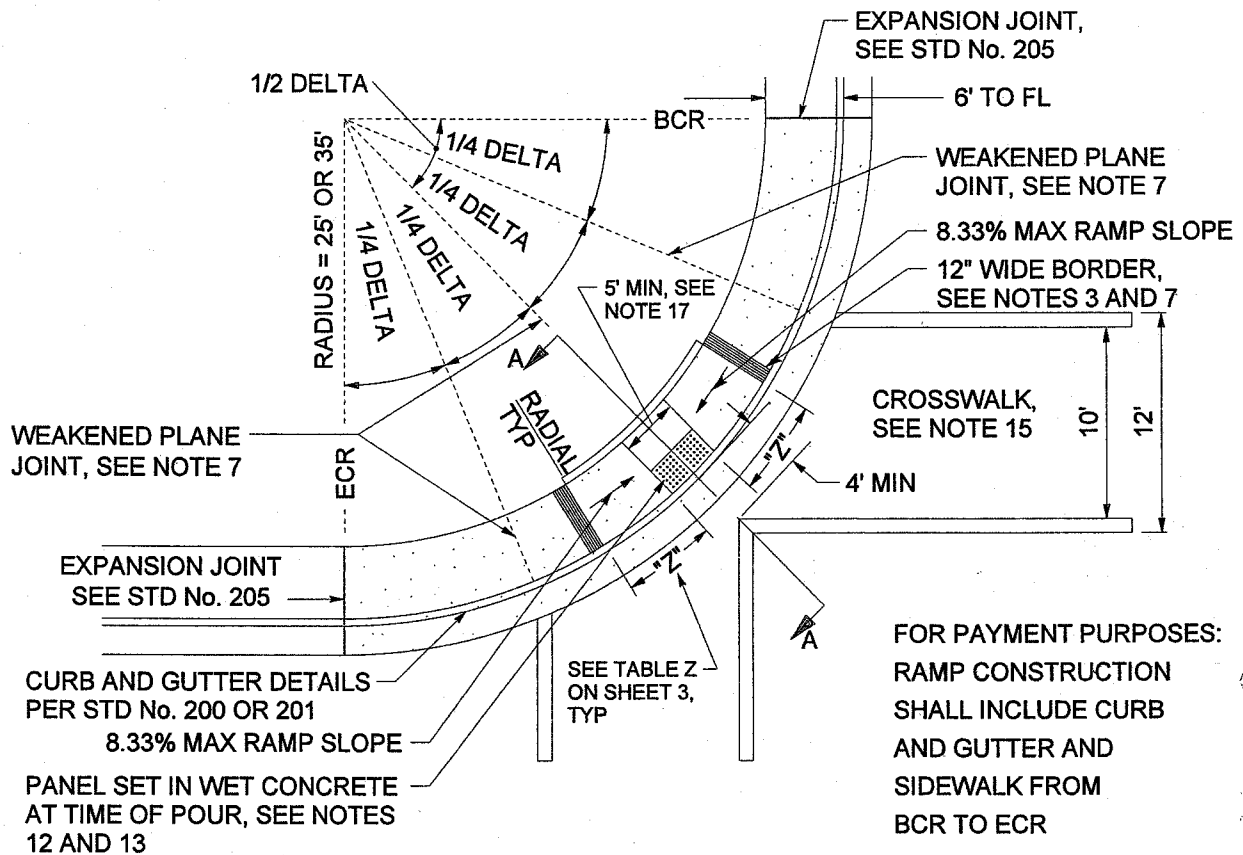

CURB AND GUTTER DETAILS PER STD No. 200 OR 201
 8.33% MAX RAMP SLOPE
 PANEL SET IN WET CONCRETE AT TIME OF POUR, SEE NOTES 12 AND 13

FOR PAYMENT PURPOSES:
 RAMP CONSTRUCTION SHALL INCLUDE CURB AND GUTTER AND SIDEWALK FROM BCR TO ECR

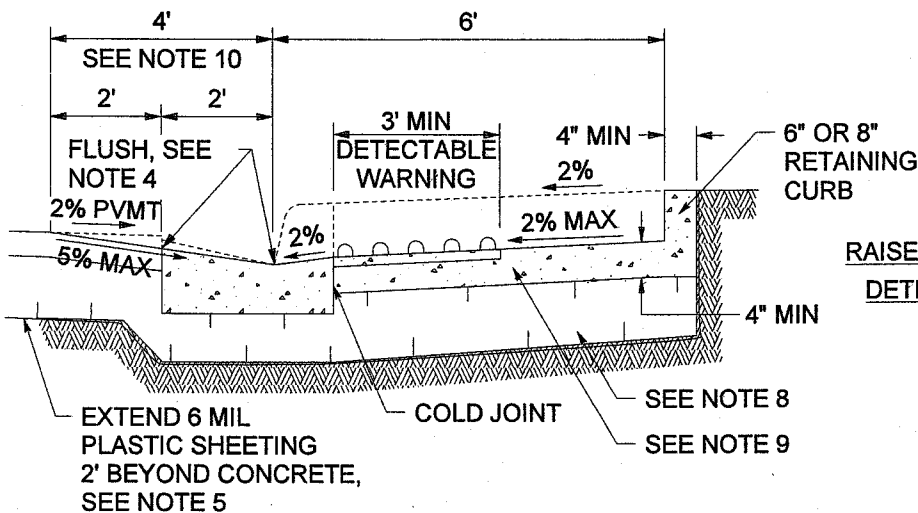

SECTION A-A

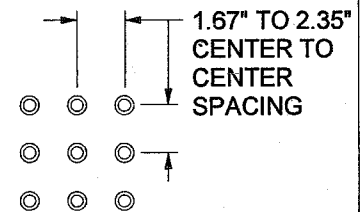

**RAISED TRUNCATED DOME PATTERN
 DETECTABLE WARNING SURFACE
 SEE NOTES 12 & 13**

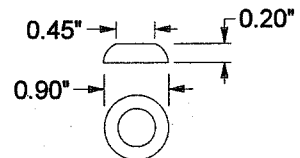

**RAISED TRUNCATED DOME
 SEE NOTE 11**

FOR NOTES SEE SHEET 7 OF 7
 SEE NOTE 16 FOR CONSTRUCTION TOLERANCES

APPROVED BY:

DATE: 11/15/04

DIRECTOR OF TRANSPORTATION
 JUAN C. PEREZ, RCE 49568

DATE



COUNTY OF RIVERSIDE

**CURB RAMP
 CASE B**

NO SCALE

STANDARD No. 403 (2 OF 7)

REVISIONS	REV	BY:	APR'D	DATE	REV	BY:	APR'D	DATE
8-77, 5-80	11-04	1	JK	JP	08-05-10			
10-81, 6-82		2						
9-88, 2-90		3						

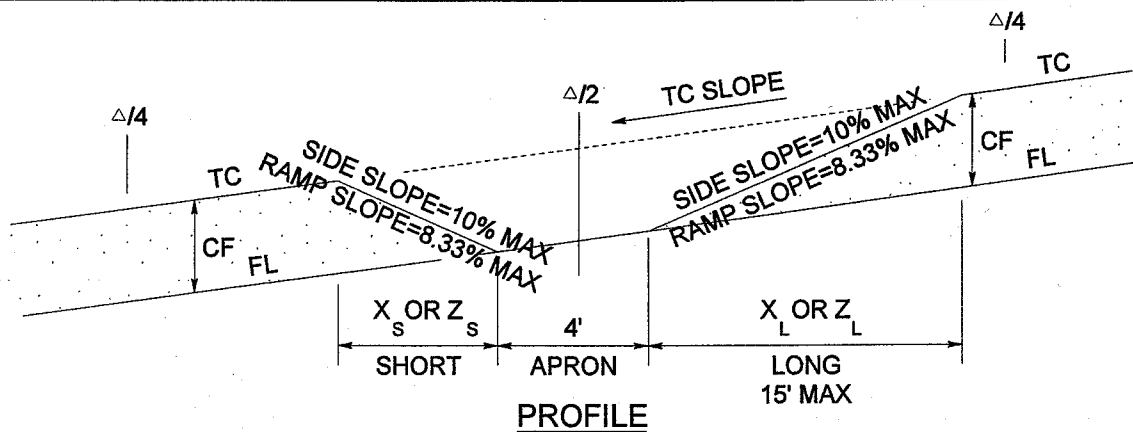

TABLE X - CASE A FLARED SIDE SLOPES

CF (IN)	RADIUS (FT)	SIDE SLOPE	X	TC GRADE (ALONG CURB RETURN)					
				1%	2%	3%	4%	5%	6%
6"	35'	10%	X _S	4.6	4.2	3.9	3.6	3.4	3.2
			X _L	5.6	6.3	7.2	8.4	10.0	12.5
8"	35'	10%	X _S	6.1	5.6	5.2	4.8	4.5	4.2
			X _L	7.5	8.4	9.6	11.2	13.4	15.0*

TABLE Z - CASE B AND C RAMP SLOPES

CF (IN)	RADIUS (FT)	RAMP SLOPE	Y	TC SLOPE (ALONG CURB RETURN)					
				1%	2%	3%	4%	5%	6%
6"	35'	8.33%	Y _S	5.4	4.8	4.4	4.1	3.8	3.5
			Y _L	6.8	7.9	9.4	11.5	15.0*	15.0*
8"	35'	8.33%	Y _S	7.1	6.4	5.9	5.4	5.0	4.6
			Y _L	9.1	10.5	12.5	15.0*	15.0*	15.0*

* NOTE: MAXIMUM ADA SLOPES HAVE BEEN EXCEEDED. ENGINEER IS REQUIRED TO FILE A DESIGN EXCEPTION FOR TECHNICAL INFEASIBILITY.

TO CALCULATE "X" DIMENSION:

SHORT SIDE (DOWN SLOPE): $X_S \text{ OR } Y_S \text{ (FT)} = \frac{\text{CURB FACE (FT)}}{\text{SIDE OR RAMP SLOPE} + \text{TC SLOPE}}$
 LONG SIDE (UP SLOPE): $X_L \text{ OR } Y_L \text{ (FT)} = \frac{\text{CURB FACE (FT)}}{\text{SIDE OR RAMP SLOPE} - \text{TC SLOPE}}$

ENGINEER TO SHOW X_S, X_L, Y_S, AND Y_L ON IMPROVEMENT PLANS

SEE NOTE 16 FOR CONSTRUCTION TOLERANCES

APPROVED BY:				COUNTY OF RIVERSIDE				
DATE: 11/15/04				CURB RAMP PROFILE NO SCALE STANDARD No. 403 (3 OF 7)				
DIRECTOR OF TRANSPORTATION JUAN C. PEREZ, RCE 49568		DATE						
REVISIONS	REV	BY:	APR'D	DATE	REV	BY:	APR'D	DATE
8-77, 5-80	11-04	1	JK	JP	08-05-10			
10-81, 6-82		2						
9-88, 2-90		3						

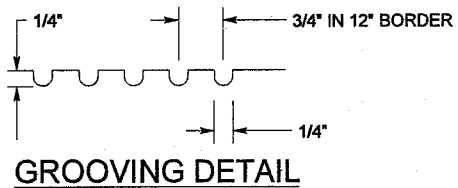
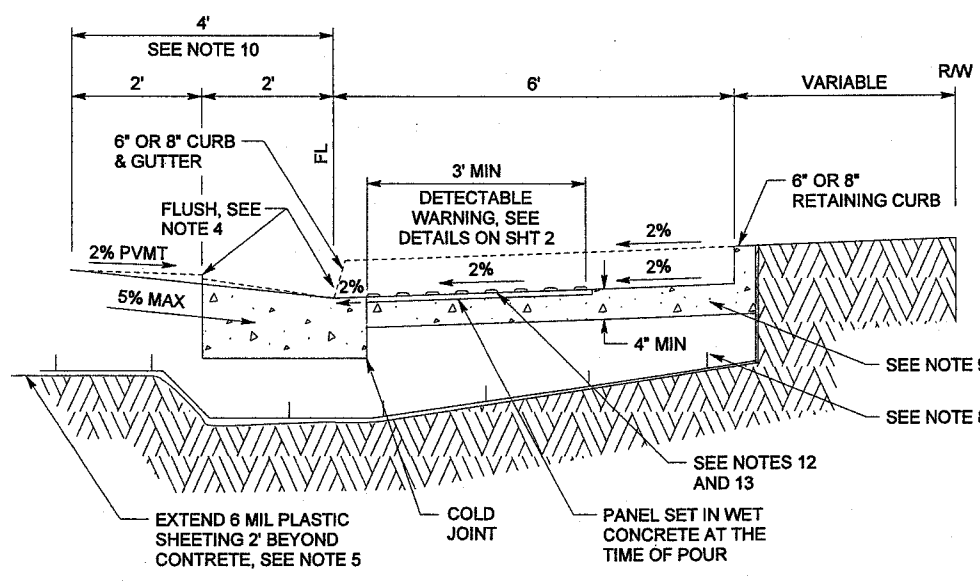
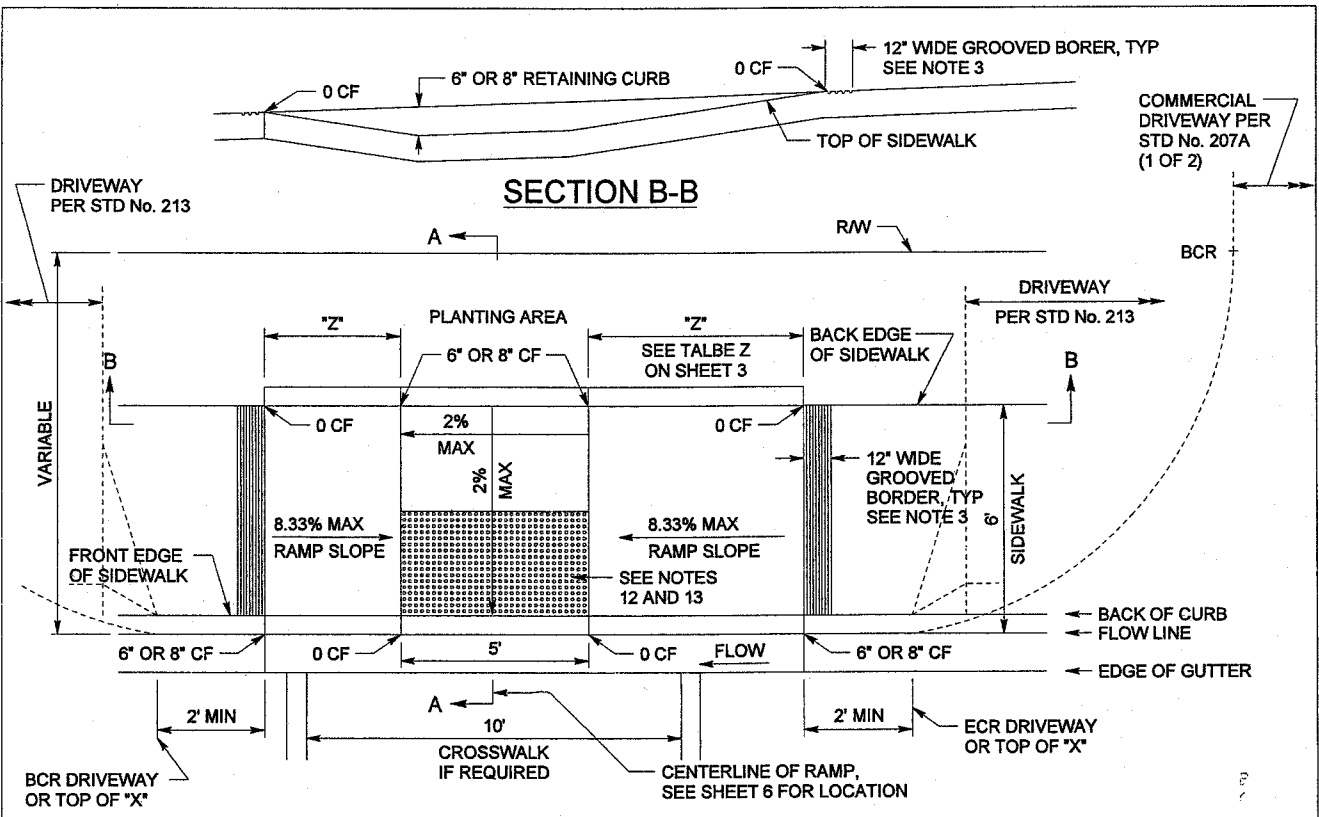

FOR NOTES SEE SHEET 7 OF 7
SEE NOTE 16 FOR CONSTRUCTION TOLERANCES

APPROVED BY: _____
DATE: 00/00/00
DIRECTOR OF TRANSPORTATION _____ DATE
JUAN C. PEREZ, RCE 49568



COUNTY OF RIVERSIDE
**CURB RAMP-CASE C
"T" INTERSECTION
WITH SIDEWALK AT CURB**
NO SCALE

REVISIONS	REV	BY	APR'D	DATE	REV	BY	APR'D	DATE
	1	JK	JP	08-05-10				
	2							
	3							

STANDARD No. 403 (4 OF 7)

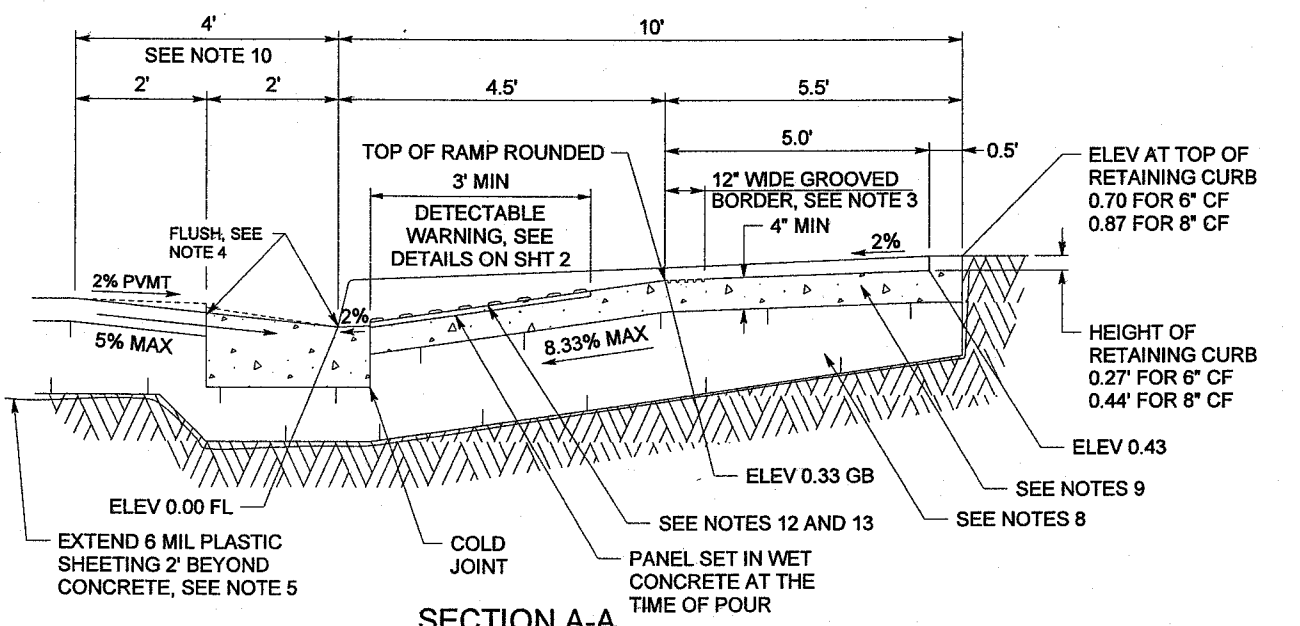
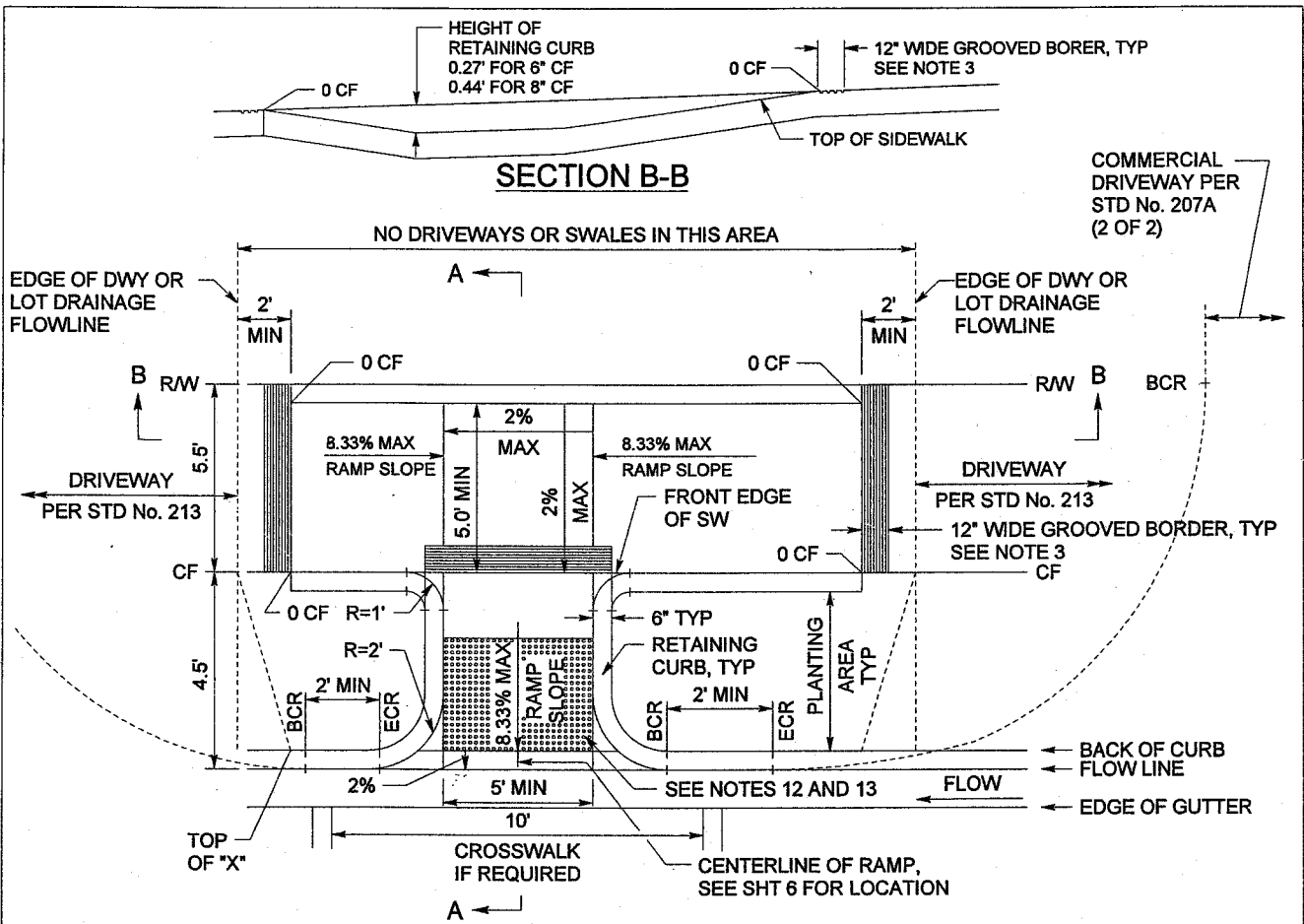

FOR NOTES SEE SHEET 7 OF 7
SEE NOTE 16 FOR CONSTRUCTION TOLERANCES

APPROVED BY:				DATE: 00/00/00				
DIRECTOR OF TRANSPORTATION JUAN C. PEREZ, RCE 49568				DATE				
REVISIONS	REV	BY:	APR'D	DATE	REV	BY:	APR'D	DATE
	1	JK	JP	08-05-10				
	2							
	3							



COUNTY OF RIVERSIDE

CURB RAMP-CASE D
"T" INTERSECTION
WITH SIDEWALK AT R/W
NO SCALE

STANDARD No. 403 (5 OF 7)

DRIVEWAYS TO BE LOCATED TO NOT CONFLICT WITH REQUIRED RAMP LOCATION. SEE STD No. 403, SHEET 4 AND 5 OF COUNTY ORDINANCE No. 461. AVOID LOCATING DRIVEWAYS WITHIN INTERSECTION.

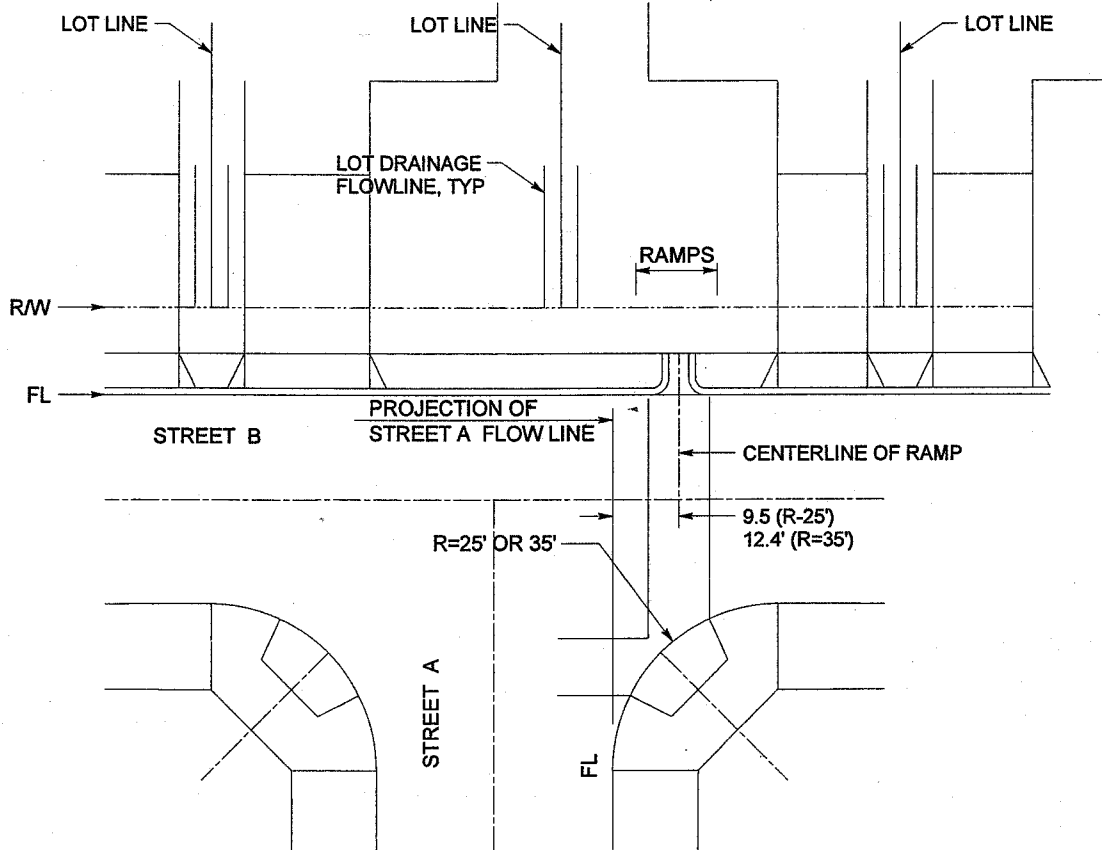

RAMP LOCATION AT "T" INTERSECTION (RIGHT TURN SIDE OF STREET A)

CASES C AND D

APPROVED BY:

DIRECTOR OF TRANSPORTATION
JUAN C. PEREZ, RCE 49568

DATE

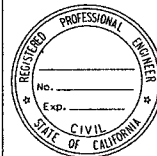

COUNTY OF RIVERSIDE

**CURB RAMP
LOCATION AT
"T" INTERSECTIONS**

NO SCALE

STANDARD No. 403 (6 OF 7)

REVISIONS	REV	BY:	APR'D	DATE	REV	BY:	APR'D	DATE
	1	JK	JC	08-05-10				
	2							
	3							

NOTES:

1. IF DISTANCE FROM CURB TO BACK OF SIDEWALK IS TOO SHORT TO ACCOMMODATE RAMP AND 4' LANDING, THEN USE THE CASE"B" RAMP.
2. THE MINIMUM SIDEWALK WIDTH IS 5' FROM BACK OF CURB TO FACE OF RETAINING CURB.
3. THE RAMP SHALL HAVE A 12" WIDE BORDER WITH GROOVES 1/4" WIDE AND 1/4" DEEP APPROXIMATELY 3/4" ON CENTER. PLACED ON THE LEVEL SIDEWALK (NOT ON THE RAMP). SEE GROOVING DETAIL ON SHEET 4.
4. TRANSITIONS FROM RAMPS TO WALKS, GUTTERS, OR STREETS SHALL BE FLUSH AND FREE OF ABRUPT CHANGES.
5. WHEN ABUTTING SOIL HAS A HIGH SULFATE CONTENT, SPECIAL CONSIDERATIONS ARE REQUIRED. SEE SPECIFICATIONS (SECTION 16.04).
6. FLARED SIDE SLOPE VARIES UNIFORMLY FROM A MAXIMUM OF 10% AT CURB TO CONFORM WITH LONGITUDINAL SIDEWALK SLOPE ADJACENT TO THE TOP OF THE RAMP.
7. CONSTRUCT WEAKENED PLANE JOINTS AT 1/4 DELTAS WHEN RADIUS EQUALS 35' AND AT INSIDE EDGE OF GROOVED BORDER WHEN RADIUS EQUALS 25'.
8. IF EXPANSIVE SOIL IS ENCOUNTERED, THEN RAMP SHALL BE CONSTRUCTED OVER CLASS 2 AGGREGATE MATERIAL.
9. CONCRETE SHALL BE CLASS B.
10. MAXIMUM SLOPES OF ADJOINING GUTTERS: THE ROAD SURFACE AND GUTTER SURFACE SHALL NOT EXCEED 5% WITHIN 4' OF THE CURB RAMP.
11. DETECTABLE WARNING SURFACES ARE REQUIRED ON ALL CURB RAMPS THAT ENTER INTO A VEHICULAR TRAVEL WAY.
12. CURB RAMPS SHALL HAVE A YELLOW DETECTABLE WARNING SURFACE THAT EXTENDS THE FULL WIDTH AND 3'-0" DEPTH OF THE RAMP. DETECTABLE WARNING SURFACES SHALL CONSIST OF A PANEL SET INTO WET CONCRETE AND CONFORM TO THE DETAILS ON THIS STANDARD. NO BOLT DOWN OR GLUE DOWN ALLOWED FOR NEW RAMP CONSTRUCTION.
13. THE EDGE OF THE DETECTABLE WARNING SURFACE NEAREST THE STREET SHALL BE BETWEEN 6" AND 8" FROM THE GUTTER FLOWLINE.
14. UTILITY PULL BOXES, MANHOLES, VAULTS AND ALL OTHER UTILITY FACILITIES ARE NOT TO BE LOCATED WITHIN THE BOUNDARIES OF THE CURB RAMP. EXISTING STRUCTURE TO BE RELOCATED OR ADJUSTED TO GRADE BY THE OWNER PRIOR TO, OR IN CONJUNCTION WITH, CURB RAMP CONSTRUCTION.
15. CROSSWALK STRIPING ONLY IF SHOWN ON IMPROVEMENT PLANS. CROSSWALK STRIPING, WHEN CALLED FOR, PER STD No. 403 (1 OF 7).
16. TO MEET AMERICAN WITH DISABILITIES ACT STANDARDS, MAXIMUM STATED SLOPES ARE ABSOLUTE AND NO CONSTRUCTION TOLERANCES WILL BE ALLOWED TO INCREASE THE SLOPES.
17. FOR CASE B, THE LEVEL LANDING AT THE BOTTOM OF THE RAMPS SHALL BE 5' WIDE. EXISTING CASE B LANDINGS THAT ARE 4' WIDE ARE ACCEPTABLE.

APPROVED BY: _____ DATE: 11/15/04 DIRECTOR OF TRANSPORTATION _____ DATE JUAN C. PEREZ, RCE 49568						COUNTY OF RIVERSIDE CURB RAMP CONSTRUCTION NOTES NO SCALE STANDARD No. 403 (7 OF 7)				
REVISIONS	REV	BY:	APR'D	DATE	REV	BY:	APR'D	DATE		
8-77, 5-80	11-04	1	JK	JP	08-05-10					
10-81, 6-82		2								
9-88, 2-90		3								

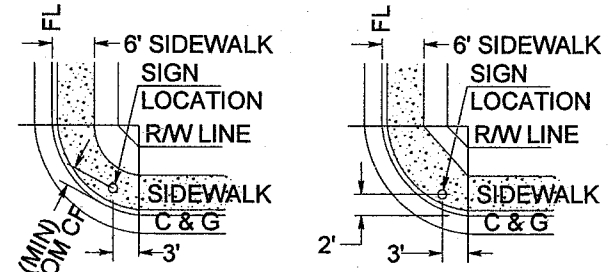
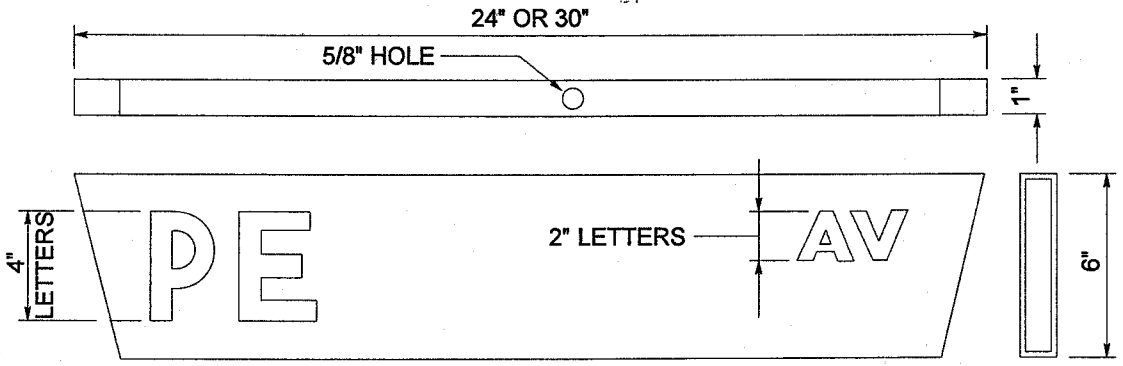
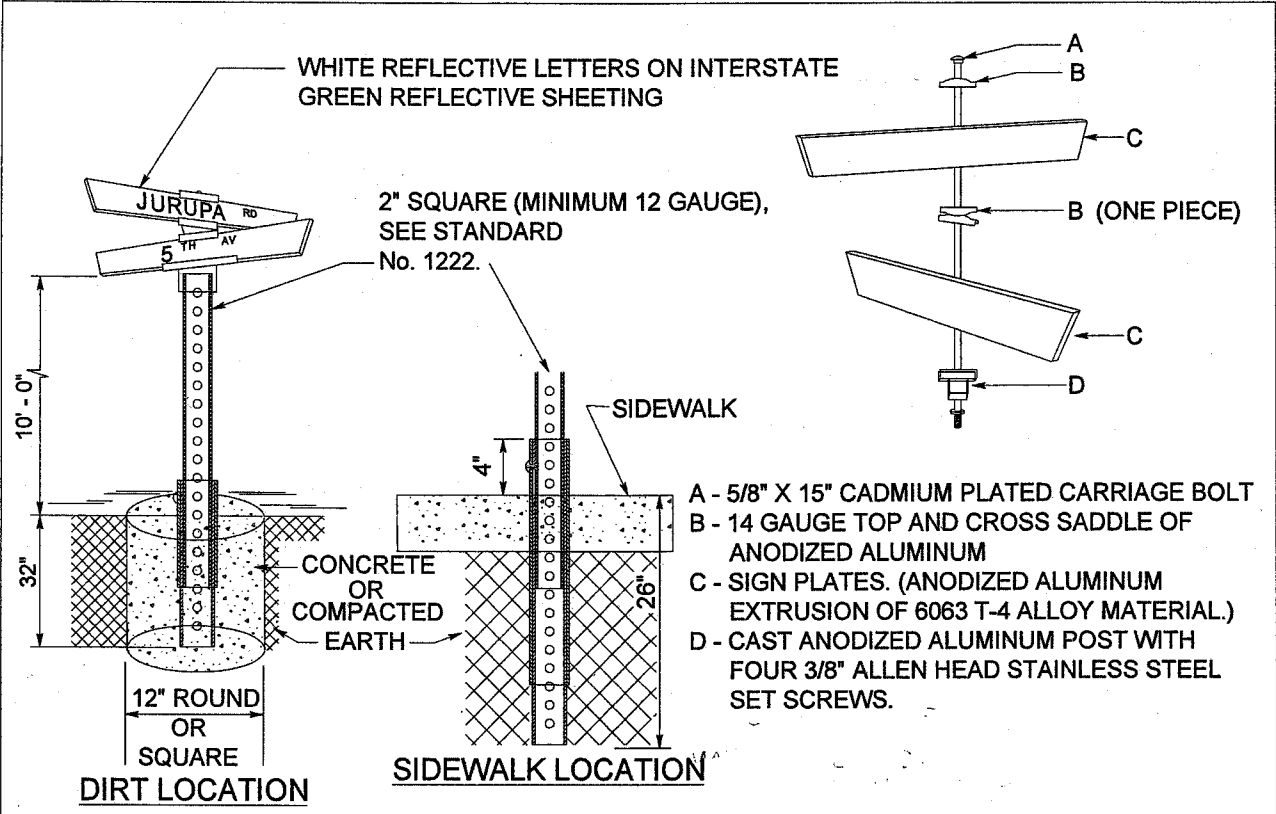

NOTE:
ONE COMPLETE NAME SIGN UNIT IS REQUIRED
AT EACH INTERSECTION WHEN PAVED WIDTHS
OR CURBED WIDTHS OF ALL INTERSECTING
STREETS ARE 40 FEET OR LESS. AT INTER-
SECTIONS WITH AN ULTIMATE PAVED WIDTH
OR CURBED WIDTH GREATER THAN 40 FEET,
USE STANDARD 1220. STD 1221 IS INTENDED
FOR RESIDENTIAL STREETS WITHIN A TRACT.
OTHER TYPES OF INTERSECTIONS, USE
STD 1220.

**INSIDE OF KNUCKLE INTERSECTION
SIGN INSTALLATION DETAILS**

APPROVED BY:								COUNTY OF RIVERSIDE	
DIRECTOR OF TRANSPORTATION JUAN C. PEREZ, RCE 49568								DATE	
REVISIONS		REV.	BY:	APR'D	DATE	REV.	BY:	APR'D	DATE
		1	JK	JP	08-05-10	4			
		2				5			
		3				6			
								STANDARD No. 1221	

RIVET LOCATIONS
SEE NOTE 6 ON
SHEET 2 OF 2

DIRECTION OF
TRAFFIC FLOW

STREET SIDE
OF POST

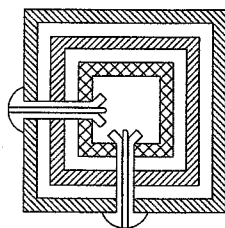

SECTION "A-A"

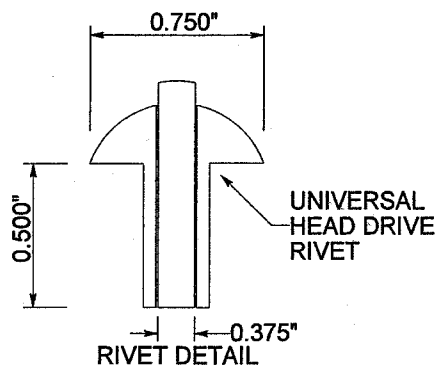

RIVET DETAIL

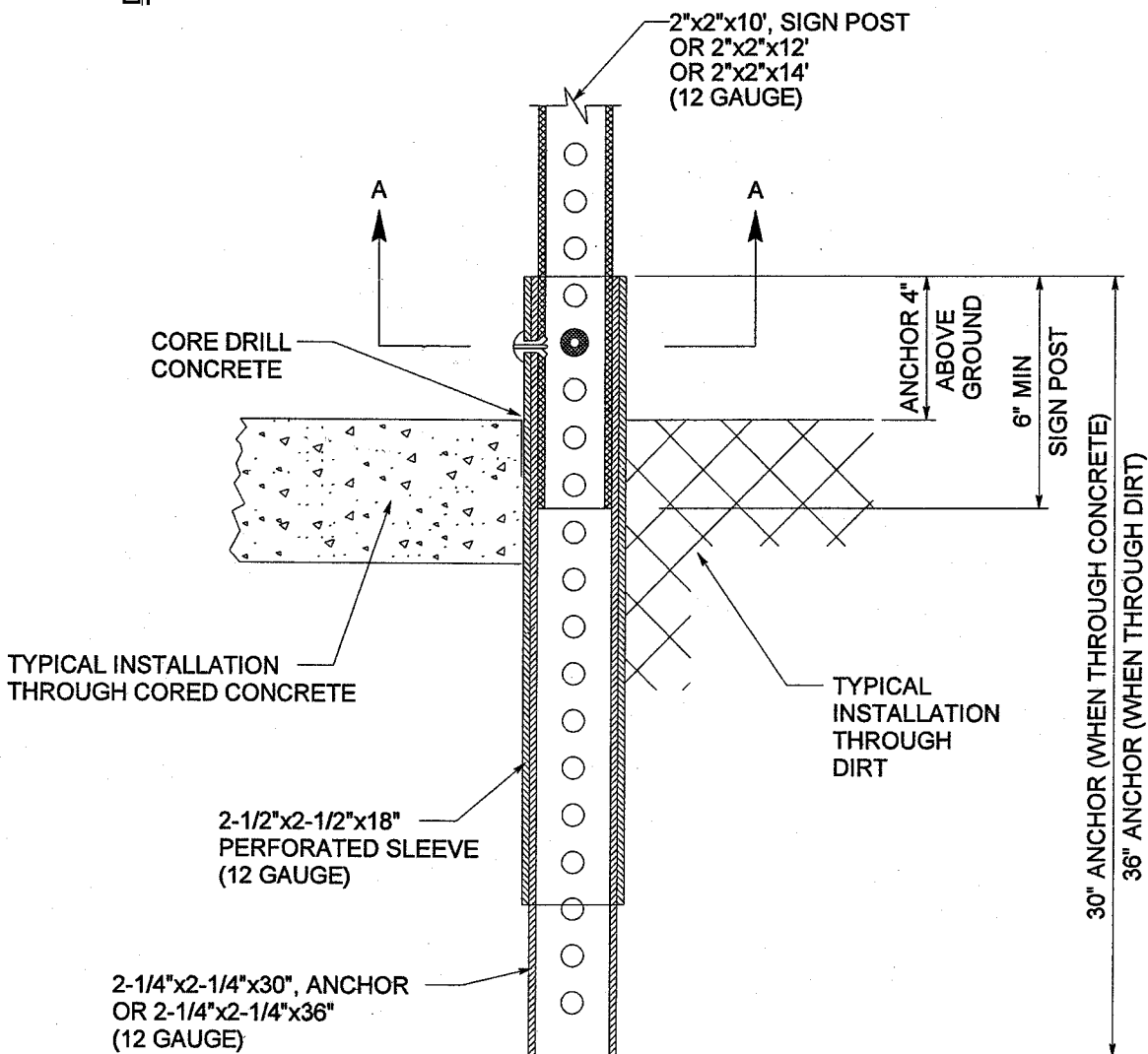

APPROVED BY:

DIRECTOR OF TRANSPORTATION
JUAN C. PEREZ, RCE 49568

DATE



COUNTY OF RIVERSIDE

**SIGN POST
INSTALLATION**

REVISIONS	REV.	BY:	APR'D	DATE	REV.	BY:	APR'D	DATE
	1	JK	JP	08-05-10	4			
	2				5			
	3				6			

STANDARD No. 1222 (1 of 2)



RAISED IRRUCCATED DOME

NOTES:

- As site conditions dictate, Cases A through Case G curb ramps may be used for corner installations similar to those shown in Detail A and Detail B. The case of curb ramps used in Detail A do not have to be the same. Case A through Case G curb ramps also may be used at mid block locations, as site conditions dictate.
- If distance from curb to back of sidewalk is too short to accommodate ramp and 4'-0" platform (landing), as shown in Case A, the sidewalk may be depressed longitudinally as in Case B, or C or may be widened as in Case D.
- When ramp is located in center of curb return, crosswalk configuration must be similar to that shown for Detail B.
- As site conditions dictate, the retaining curb side and the flared side of the Case G ramp shall be constructed in reversed position.
- If located on a curve, the sides of the ramp need not be parallel, but the minimum width of the ramp shall be 4'-0".
- Slope of ramp flares vary uniformly from a maximum of 10% of curb to conform with longitudinal sidewalk slope adjacent to top of the ramp, except in Case C and Case F.
- The curb ramp shall be outlined, as shown, with a 1'-0" wide border with 1/2" grooves approximately 3/4" on center. See grooving detail.
- Transitions from edges and landing to walks, gutters or streets shall be flush and free of abrupt changes.
- Maximum slopes of adjoining gutters, the road surface immediately adjacent to the curb ramp or accessible route shall not exceed 5 percent within 5'-0" of the top and bottom of the curb ramp.
- Curb ramps shall have a detectable warning surface that extends the full width and 3'-0" depth of the ramp. Detectable Warning Surfaces shall conform to the details on this plan and the requirements in the Special Provisions.
- The edge of the detectable warning surface nearest the street shall be between 6" and 8" from the gutter flange.
- Sidewalk and ramp thickness, "T", shall be 3/8" minimum.
- Utility and boxes, manholes, vaults and all other utility facilities within the right-of-way of the street shall be installed and adjusted to grade by the owner prior to, or in conjunction with, curb ramp construction.
- For retrofit conditions, removal and replacement of curb apron will be at the Contractor's option, unless otherwise shown on project plans.

**RAISED IRRUCCATED DOME PATTERN (IN-LINE)
DETECTABLE WARNING SURFACE**

See Note 10

STATE OF CALIFORNIA
DEPARTMENT OF TRANSPORTATION

CURB RAMP DETAILS

NO SCALE

RSP A88A DATED SEPTEMBER 1, 2006 SUPERSEDES STANDARD PLAN A88A
DATED MAY 1, 2006 - PAGE 115 OF THE STANDARD PLANS BOOK DATED MAY 2006.

REVISED STANDARD PLAN RSP A88A

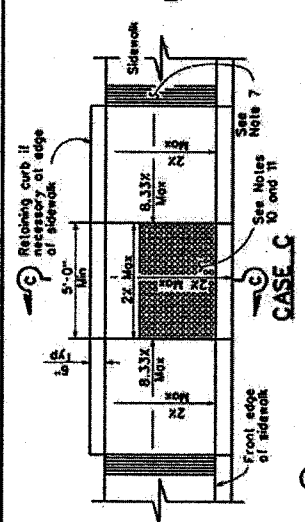

CASE C

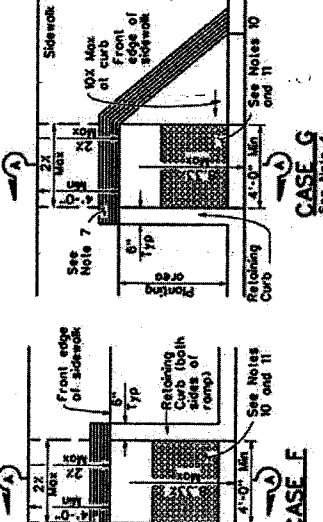

CASE G

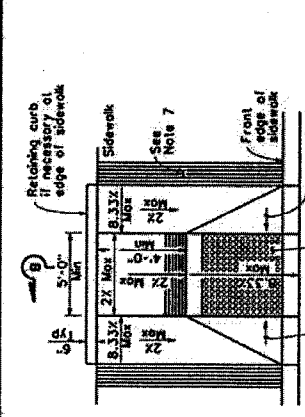

CASE B

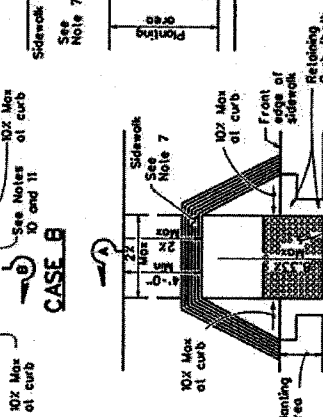

CASE F

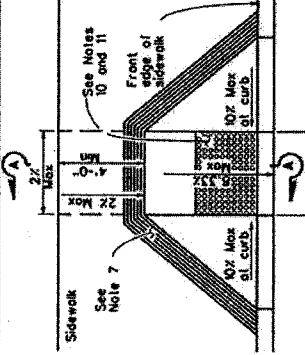

CASE A

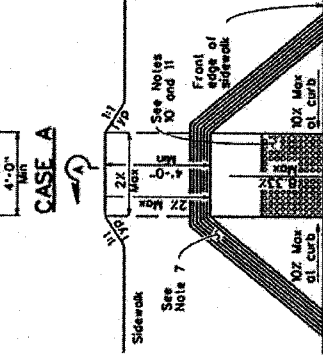

CASE D

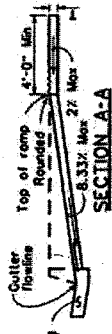

SECTION A-A

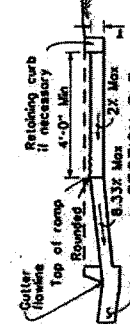

SECTION B-B

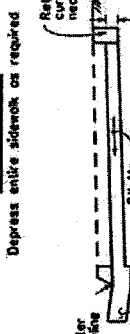

SECTION C-C

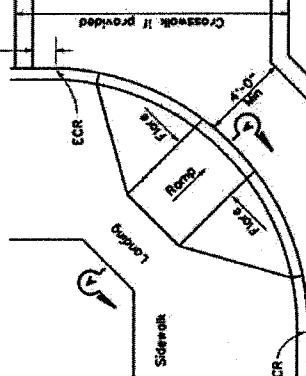

**DETAIL B
TYPICAL ONE-RAMP
CORNER INSTALLATION**

See Notes 1 and 3

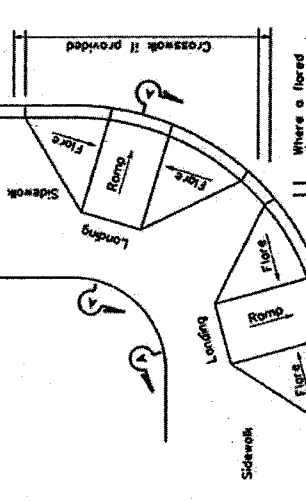

**DETAIL A
TYPICAL TWO-RAMP CORNER INSTALLATION**

See Note 1

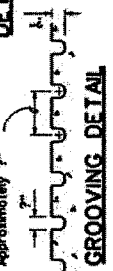

GROOVING DETAIL



RETROFIT DETAIL

Existing curb and sidewalk

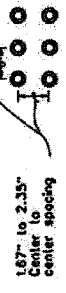

1.67" to 2.35"
Center to
center spacing



OFFICE OF
CLERK OF THE BOARD OF SUPERVISORS
1st FLOOR, COUNTY ADMINISTRATIVE CENTER
P.O. BOX 1147, 4080 LEMON STREET
RIVERSIDE, CA 92502-1147
PHONE: (951) 955-1060
FAX: (951) 955-1071

KECIA HARPER-IHEM
Clerk of the Board of Supervisors

KIMBERLY A. RECTOR
Assistant Clerk of the Board

November 5, 2013

THE PRESS ENTERPRISE
ATTN: LEGALS
PO BOX 792
RIVERSIDE, CA 92501

FAX (951) 368-9018
E-MAIL: legals@pe.com

RE: NOTICE INVITING BIDS: Avenida Florencita Sidewalk Project

To Whom It May Concern:

Attached is a copy for publication in your newspaper for **TEN (10) TIMES:**

Friday	- November 8, 2013	Wednesday	- November 13, 2013
Saturday	- November 9, 2013	Thursday	- November 14, 2013
Sunday	- November 10, 2013	Friday	- November 15, 2013
Monday	- November 11, 2013	Saturday	- November 16, 2013
Tuesday	- November 12, 2013	Sunday	- November 17, 2013

We require your affidavit of publication immediately upon completion of the last publication.

Your invoice must be submitted to this office in duplicate, WITH TWO CLIPPINGS OF THE PUBLICATION.

NOTE: PLEASE COMPOSE THIS PUBLICATION INTO A SINGLE COLUMN FORMAT.

Thank you in advance for your assistance and expertise.

Sincerely,

Karen Barton

Board Assistant to:
KECIA HARPER-IHEM, CLERK OF THE BOARD



OFFICE OF
CLERK OF THE BOARD OF SUPERVISORS
1st FLOOR, COUNTY ADMINISTRATIVE CENTER
P.O. BOX 1147, 4080 LEMON STREET
RIVERSIDE, CA 92502-1147
PHONE: (951) 955-1060
FAX: (951) 955-1071

KECIA HARPER-IHEM
Clerk of the Board of Supervisors

KIMBERLY A. RECTOR
Assistant Clerk of the Board

November 5, 2013

THE DESERT SUN
ATTN: LEGALS
PO BOX 2734
PALM SPRINGS, CA 92263

FAX (760) 778-4731
E-MAIL: legals@thedesertsun.com

RE: NOTICE INVITING BIDS: Avenida Florencita Sidewalk Project C3-0050

To Whom It May Concern:

Attached is a copy for publication in your newspaper for **FIVE (5) TIMES:**

Friday	- November 8, 2013
Saturday	- November 9, 2013
Sunday	- November 10, 2013
Wednesday	- November 13, 2013
Thursday	- November 14, 2013

We require your affidavit of publication immediately upon completion of the last publication.

Your invoice must be submitted to this office in duplicate, WITH TWO CLIPPINGS OF THE PUBLICATION.

NOTE: PLEASE COMPOSE THIS PUBLICATION INTO A SINGLE COLUMN FORMAT.

Thank you in advance for your assistance and expertise.

Sincerely,

Karen Barton

Board Assistant to:
KECIA HARPER-IHEM, CLERK OF THE BOARD

Notice to Bidders

County of Riverside, herein called Owner, invites sealed proposals for:

**Avenida Florencita
Sidewalk Project
Between Camino Aventura and Camino Campanero
Project No. C3-0050
In the Southeast Desert Hot Springs Community**

Bid shall be delivered to the County of Riverside Transportation Department, 14th Street Annex, 3525 14th Street, Riverside, California 92501, telephone (951) 955-6780 not later than 2:00 p.m., on Wednesday, **December 4, 2013** to be promptly opened in public at said address. Each bid shall be in accordance with plans, specifications and other contract documents, dated **September 2013**, and prepared by County of Riverside, whose address is same as the above, from whom they may be obtained upon deposit of **\$30.00** per set with 24" x 36" plans, plus mailing costs. No refund. Prospective bidders may preview the plans, specifications and other contract documents at no charge prior to purchase at the above noted location.

The Contractor is required to have a Class "A" or C12 (Earthwork and Paving) license at the time of bid submission.

Engineering Estimate	
Base Bid:	\$ 152,000 - \$ 184,500
Bid Bond	10 %
Performance Bond	100 %
Payment Bond	100 %
Working Days	40 Working Days
Website:	http://www.rctlma.org/trans/con_bid_advertisements.html

Dated: November 5, 2013

Kecia Harper-Ihem, Clerk of the Board
By: Karen Barton, Board Assistant