

Service Identification

The service address shall be shown on the front upper panel of the service equipment enclosure, and the meters shall be labeled "LS3" (lighting meter) and "TC1" (signal meter) by lettering applied to the exterior of the enclosure in accordance with these special provisions, or as directed by the Engineer.

Lettering markings shall be black with a two-inch minimum size in block letter form. Markings shall be applied to a brushed aluminum, stainless steel, or other non-corroding metallic plate, as approved by the Engineer. Plate shall be white in color. All paint and markings shall conform in all respects to Federal Specification TT-E-489, latest revision, Class A, Air Drying. Said plate shall be affixed in a permanent manner by riveting or with stainless steel bolts and nuts. Bolts shall be peened after tightening. All materials used for affixing address plate shall be non-corroding. The Engineer shall approve all alternate materials and methods prior to installation.

O. Testing

Testing and Field Testing shall conform to the provisions in Section 86-2.14, "Testing", of the Standard Specifications and these Special Provisions.

Specific testing requirements for various systems and components shall be in accordance with the Special Provisions entitled to each herein.

The complete controller assembly and Battery Backup System shall be delivered to the following location or location as directed by the Engineer for testing:

Traffic Signal Shop
Riverside County Transportation Department
McKenzie Highway Operations Center
2950 Washington Street
Riverside, California 92504
Telephone (951) 955-6894

A minimum of 15 working days for operational testing and adjustment is required. An additional 15 working days period shall be allowed for retesting should the equipment fail.

The conflict monitor unit shall be tested in the field before signal turn on.

P. Controller Assembly

Controller assembly shall conform to the provisions in Section 86-3, "Controller Assemblies", of the Standard Specifications and these Special Provisions.

Controller assembly shall be Model 170 controller assembly consisting of the additional features:

1. Model 332L controller cabinet:
 - Anodic coating for both interior and exterior finish
 - A Corbin No. 2 door lock
2. An interior fluorescent lamp with an on/off switch and a door switch that will automatically turn on the lamp when cabinet door is opened.
3. An interior thermostatically controlled, 24 volt electric fan with ball or roller bearing that has capacity rating of 100 cubic feet per minute minimum.
4. Rack mounted push buttons for manual actuation of the following:
 - 8 vehicular phases,

- 4 pedestrian phases,
 - 4 Emergency Vehicle Preemption (EVP) phases; and,
 - 2 Railroad preemption phases.
5. Model 170E local controller unit:
 - Dual Asynchronous Communications Interface Adaptor (ACIA) capability. ACIA shall be integral to the controller unit. Horizontal printed circuit board controllers will not be accepted.
 - A Model 412F Program Module with 32K 27256 EPROM, 16K RAM, and 8K zero power RAM (memory method two, memory select four).
 - Bi Trans Systems, Inc. 233RV2.5 or latest version firmware, test program and a loopback cable.
 - If required, provide a Model 170E field master controller unit that has the same features as the 170E local controller except the firmware shall be Bi Tran Systems, Inc. No. 245 FM. It shall be mounted above the local controller unit.
 6. A pullout shelf/drawer assembly made of aluminum with telescoping drawer guides for full extension installed below the local controller unit. The top shall have a non-slip plastic laminate permanently attached. The non-slip laminate shall not be attached with silicon adhesive.
 7. Load Switches: Switching circuit shall be contained in a replacement module (cube type) sealed in epoxy and rated at 15 amperes load (25 Amp triac). Pin 11 on all load switch sockets shall be wired to AC. Input and output indicators shall be installed on all load switches.

All load switch sockets shall have individual wire terminals. Printed circuit boards will not be allowed.
 8. Flasher units: Switching circuit shall be contained in a replacement module (cube type) sealed in epoxy and rated at 15 amperes load (25 Amps triac).
 9. Conflict monitor shall be EDI Model 2010ECL or equivalent with a red monitor assembly circuit board and capable of monitoring green, amber and red indications.
 10. Loop detector sensor unit shall be Model 222:
 - Detector unit shall have delay timers adjustable from zero to a minimum of 30 seconds and extension timers adjustable from zero to a minimum of 7 seconds.
 - Delay timers shall delay calls only during display of the associated red or yellow indications. If a vehicle departs the area of detection prior to expiration of the assigned delay period, the timer shall reset and no call shall be placed upon the controller. During display of the associated green indication, detectors shall operate in the present mode and calls shall not be delayed.
 11. Power Distribution Assembly shall be Model PDA-2.
 12. A twelve-position interconnect terminal strip.

The contractor shall furnish the following spare equipments / components:

Description	Model	Quantity
Cabinet	332	0
Controller Unit (local)	170E	0
Controller Unit (master)	170E	0
Switch Pack	200	0
Flasher Unit	204	0
Conflict Monitor Unit	2010	0
2-Channel Loop Detector	222	0
2-Channel DC Isolator	242	0
Modem Module	400	0
Program Module	412F	0

Spare equipments or components shall be delivered to the following location or as directed by the Engineer:

Traffic Signal Shop
 Riverside County Transportation Department
 McKenzie Highway Operations Center
 2950 Washington Street
 Riverside, California 92504
 Telephone (951) 955-6894

The controller unit and controller cabinet shall be manufactured and furnished by the same manufacturer to form a complete functional controller system capable of providing the traffic signal operation specified. All traffic control equipment to be furnished shall be listed on the California Department of Transportation Qualified Products List.

The controller unit and controller cabinet manufacturer or supplier shall perform operational and functional testing of the supplied controller assembly and additional supplied equipment in accordance with the State of California Department of Transportation's Transportation Electrical Equipment specifications (TEES), and a Certificate of Compliance shall be issued for each successfully tested controller assembly and additional supplied equipment.

Modify traffic signal controller assembly if necessary and provide any necessary auxiliary equipment and cabling to achieve the intended traffic signal operation as shown on the plans. The Contractor shall make all field wiring connections to the terminal blocks inside the controller cabinet.

A technician who is qualified to work on the controller assembly from the controller manufacturer or their representative shall install the program module and program the signal controller in accordance with the Engineer provided signal timing sheets, and to be present when the equipment is turned on.

Q. Vehicle Signal Assemblies

Vehicle signal assemblies and auxiliary equipment shall conform to the provisions in Section 86 4, "Traffic Signal Faces and Fittings", of the Standard Specifications and these Special Provisions.

Signal sections, backplates, visors and signal mounting assemblies shall be the metal type and shall be made from the same manufacturer. The section assemblies shall be uniform in appearance and alignment.

Backplates shall be louvered. Visors shall be the "tunnel" type. Top opening of signal sections shall be sealed with neoprene gaskets.

Vehicle signal indications shall be 12-inch diameter Light Emitting Diode (LED) modules in accordance with the following:

1. All circular LED modules shall comply with Institute of Transportation Engineers (ITE) Vehicle Traffic Control Signal Heads (VETCH) - LED Circular Supplement, Adopted June 27, 2005.
2. All arrow LED modules shall comply with ITE VETCH - LED Vehicle Arrow Traffic Signal Supplement, Adopted July 1, 2007.
3. All modules shall fit in existing signal housings without the use of special tools.
4. All modules shall be certified in the Intertek LED Traffic Signal Modules Certification Program and be labeled with the ETL Verified Label as follows:

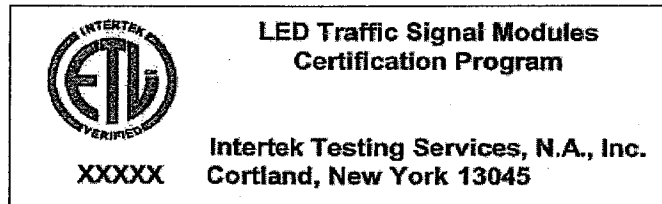

5. Luminous intensity requirements of the VTCSH must be met across the entire temperature range from -40°C to +74°C, (-40°F to +165°F).
6. The following cable colors shall be used for the AC power leads on all modules: white for common, red for the red module line, yellow for the yellow module line, and brown for the green module line.
7. The AC power leads shall exit the module via a rubber grommet strain relief, and shall be terminated with quick connect terminals with spade tab adapters. The leads shall be separate at the point at which they leave the module.
8. All external wiring used in the module shall be anti-capillary type cable to prevent the wicking of moisture to the interior of the module.
9. All power supplies shall be coated for additional moisture and thermal protection.
10. The module shall have an incandescent, non-pixelated appearance when illuminated.
11. Nominal power usage is measured at 25°C, 120 VAC. For the 8 inch modules, it shall not exceed 8 watts for Red, 10 watts for Yellow, and 8 watts for Green modules. For the 12 inch modules, it shall not exceed 8 watts for Red, 13 watts for Yellow, and 10 watts for Green modules. For the arrows, it shall not exceed 8 watts for Red, 13 watts for Yellow, and 8 watts for Green modules.

12. All modules shall use LEDs that have been manufactured with materials that have industry acceptance as being suitable for uses in outdoor applications. At no time is the use of LEDs that utilize AlGaAs technology acceptable.
13. The external lens shall have a smooth outer surface to prevent the buildup of dirt and dust and shall be designed to minimize the potential for sun phantom signals.
14. The circular LED module lens material must be tinted . A tinted transparent film or coating is not permitted.
15. A module shall be sealed against dust and moisture intrusion, including rain and blowing rain per Mil-Std-810F Method 506.4, Procedure 1.
16. Arrow modules shall be clearly marked with the phrase "Suitable for mounting in any orientation".
17. Modules shall be repaired or replaced if the module fails to function as intended due to workmanship or material defects within warranty period.
18. Modules shall be repaired or replaced if the module exhibit luminous intensities less than the minimum specified values within 60 months of the date of delivery.
19. The Manufacturer shall clearly disclose the country in which the factory of module origin is located, the name of the company or organization that owns the factory including all of its parent companies and/or organizations, and their respective country of corporate citizenship.

R. Pedestrian Signal Assemblies

Pedestrian signals assemblies shall conform to the provisions in Section 86-4.03, "Pedestrian Signal Faces", of the Standard Specifications and these Special Provisions.

Pedestrian Signal Mounting Assemblies and Pedestrian Signal Housings shall be made from the same manufacturer and the section assemblies shall be uniform in appearance and alignment.

Pedestrian signals shall be provided with a polycarbonate egg crate or Z-crate screen.

Pedestrian signals shall be equipped with light emitting diode countdown pedestrian module in accordance to the following:

1. It shall comply with ITE specification: Pedestrian Traffic Control Signal Indications (PTCSI) Part 2: LED Pedestrian Traffic Signal Modules, Adopted March 19, 2004.
2. All modules shall fit in existing signal housings without the use of special tools.
3. All modules shall be certified in the Intertek LED Traffic Signal Modules Certification Program and be labeled with the ETL Verified Label as follows:

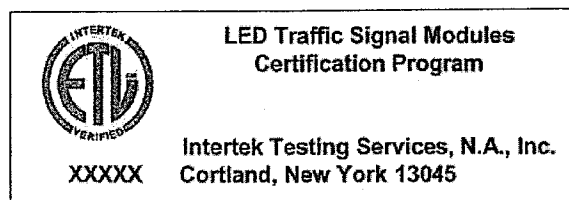

The PTCSI does not cover the countdown features of countdown pedestrian signal LED modules. The countdown features shall incorporate the following:

1. Fully compliant to NEMA TS-1, NEMA TS-2, Type 170, and Type 2070 traffic signal controller specifications.
2. The countdown portion of the pedestrian (ped) module shall have a high off-state input impedance so as not to provide a load indication to conflict monitors and interfere with the monitoring of the pedestrian signal. The input impedance of the countdown circuitry shall maintain a voltage reading above 25 VAC to the conflict monitor for up to four units connected on the same channel.
3. The countdown drive circuitry shall not be damaged when subjected to defective load switches providing a half wave signal input.
4. The countdown ped module shall have an internal conflict monitor circuit preventing any possible conflicts between the Hand, Person, and Countdown signal indications. It shall be impossible for the display to countdown during a solid Hand indication.
5. Per CA MUTCD Manual section 4E.07: "The countdown pedestrian signal shall display the number of seconds remaining until the termination of the pedestrian change interval. Countdown displays shall not be used during the walk interval or during the red clearance interval of a concurrent vehicular phase".
6. The countdown ped module shall have a micro-processor capable of recording its own time when connected to a traffic controller. It shall be capable of displaying the digits 0 through 99.
7. When power is first applied or restored to the ped module, the countdown display will be blank during the initial cycle while it records the countdown time using the walk (person) and don't walk (flashing hand) signal indications. The normal hand and person icons shall be displayed during this cycle.
8. The countdown ped module shall continuously monitor the traffic controller for any changes to the pedestrian phase time and re-program itself automatically if needed.
9. The countdown ped module shall register the time for the walk and clearance intervals individually and shall begin counting down at the beginning of the pedestrian clearance interval. The digits shall not flash during the countdown.
10. When the flashing hand becomes solid, the ped module shall display 0 for one second and then blank-out. The display shall remain dark until the beginning of the next countdown.
11. In the event of a pre-emption, the countdown ped module shall skip the remaining time, reach 0 at the same time as the flashing Hand becomes solid, and remain dark until the next cycle.
12. In the cycle following preemption call, the signal shall display the correct time and not be affected by the reduced previous cycle. The countdown shall remain synchronized with the signal indications and always reach 0 at the same time as the flashing Hand becomes solid.
13. If a pedestrian button is activated during the clearance interval, some controllers can change to a second walk cycle without a don't walk phase. The countdown module shall also be capable of consecutive walk cycles. The display digits will be blank during the second walk and countdown properly during the second flashing hand.
14. The countdown ped module shall not display an erroneous or conflicting time when subjected to defective load switches. Should there be a short power interruption during the ped clearance interval or if voltage is applied to both the hand and person simultaneously the display will go to "0" then blank.
15. The countdown ped module shall have accessible dip-switches for the user selectable options. The unit shall have a removable plug on the rear allowing easy access to control the user

selectable functions. The countdown is disabled when all the switches are in the "ON" position. The unit shall be shipped from the factory with the specified default setting.

16. Switch 1 – Blank Cycle Following a Timing Change – Factory default is "OFF". When this switch is "OFF" the unit will allow the time to be displayed normally during the cycle following a truncated timing such as a preemption call. The countdown shall be capable of displaying the correct time and not affected by the previous reduced cycle. The unit will require 2 consecutive reduced cycles of identical value to validate and record a new time setting. If the timing is extended, the unit will record it immediately. In the "ON" position when a change in timing is detected the unit will blank out during the following cycle while the new cycle time is measured and recorded if confirmed.
17. Switch 2 – Disables Auto-sync Mode- Factory default setting is "OFF". When this switch is in the "OFF" position the auto-sync is enabled. When the clearance interval begins and the initial flash of the hand is not in sync with the walk signal the unit will measure the offset and reduce the duration of the first second by the value of the offset. This will ensure the countdown reached zero at the same time as the flashing hand becomes solid. In the "ON" position there is no time correction when the flashing hand is in offset with the walk signal. The duration of the first second will not be reduced and the hand will appear solid shortly before the countdown reaches zero.
18. Switch 3 – Countdown Starts with Flashing Hand Signal – Factory default setting is "ON". When this switch is "ON" the countdown begins when the hand signal is turned on. With this switch "ON" and the auto-sync mode enabled a short power interruption will have no effect on the countdown display. With switch 3 in the "OFF" position the countdown begins when the walk signal is turned off. This eliminates the effect of an offset hand signal. When switch 3 is in the "OFF" position the auto-sync switch 2 has no effect on the countdown. In this mode if the power to the walk signal is interrupted, the unit will interpret this as the start of the clearance interval and will display the countdown time for 2 seconds before the operation is cancelled. The countdown will resume with the normal ending of the walk signal.
19. Switch 4 – Stores Time Value in Memory, Immediate. Restart. - Factory default setting is "OFF". When this switch is in the "OFF" position and power is removed from the unit, the time value stored in the unit is erased. The unit will need to run a dark cycle before it can display the countdown again. In the "ON" position the countdown timing is stored in memory. Following a power interruption, the unit will restart with the stored value and not remain dark during the learning cycle. If the value is different after restart, it will be recorded and displayed correctly at the following cycle.
20. Switch 5 – All LEDs "ON", Test Mode – Factory default setting is "OFF". With this switch in the "ON" position all LEDs are turned on simultaneously. With both switches 4 and 5 in the "ON" position the LED test mode will also scan the 7 individual segments of both digits.
21. The countdown shall be disabled when all switches are placed in the "ON" position.

22. Nominal power usage for Ped Modules at 25°C (77°F), 120 VAC input shall not exceed the values shown in Table 1.

Table 1 -- Nominal Power of Pedestrian Signals

Size	Description	Wattage @ 25°C		
		Hand	Person	Countdown ¹
16"x18"	Side by Side Hand & Person	8	7	N/A
16"x18"	Hand & Person Overlay with Countdown	9	9	8

¹ Wattage for the countdown is measured when the digits 18 are displayed.

23. All wiring shall meet the requirements of Section 13.02 of the VTCSH standard. Secured, color coded, 600V, 18 AWG jacketed wires, 1 meter (39 in) in length, conforming to the NFPA 70, National Electrical Code, and rated for service at +105°C, shall be provided.
24. The following color scheme shall be used for the ped module's AC power leads: Orange for the upraised hand, Blue for the walking person, and White for common. The countdown portion of the LED ped module shall be internally wired to the hand and walking person power.
25. The AC power leads shall exit the ped module via a rubber grommited strain relief, and shall be terminated with insulated female quick connect terminals with spade / tab adapters. The leads shall be separate at the point at which they leave the ped module.
26. All external wiring utilized in the ped modules shall be anti-capillary type wire to prevent the wicking of moisture to the interior of the ped module.
27. The Hand and Person Icons shall utilize separate power supplies. On countdown products, the countdown ped module must have its own power supply but may take the incoming AC power from the hand / person AC signal lines. All power supplies shall be located inside the ped module.
28. All power supplies shall be conformally coated for additional protection.
29. Off State Voltage Decay: When the hand or person icon is switched from the On state to the Off state the terminal voltage shall decay to a value less than 10 VAC RMS in less than 100 milliseconds when driven by a maximum allowed load switch leakage current of 10 milliamps peak (7.1 milliamps AC).
30. For a minimum period of 60 months, measured at 80 to 135 VAC RMS and over the ambient temperatures of -40°C to +74°C (-40°F to +165°F), the minimum maintained luminance values for the ped modules, when measured normal to the plane of the icon surface, shall not be less than:
- Walking Person, White: 2,200 cd/m²
 - Upraised Hand, Portland Orange: 1,400 cd/m²
 - Countdown Digits, Portland Orange: 1,400 cd/m²
31. The external lens shall have a textured outer surface to reduce glare.
32. Icons that are printed on the lens shall be on the interior surfaces in order to prevent scratching and abrasion to the icons.
33. All icons and numbers shall have a uniform incandescent non-pixelated appearance.

34. All exposed components of a ped module shall be suitable for prolonged exposure to the environment, without appreciable degradation that would interfere with function or appearance. As a minimum, selected materials shall be rated for service for a period of a minimum of 60 months in a south-facing Arizona Desert installation.
35. All LEDs used to illuminate the ped module shall use material that has industry acceptance for use in outdoor applications. At no time is the use of LEDs that utilize AlGaAs technology acceptable.
36. The countdown display shall consist of two 7 segment digits as shown below. All countdown display digits shall be 9 inches in height for use in all size crosswalks in compliance with MUTCD recommendations.

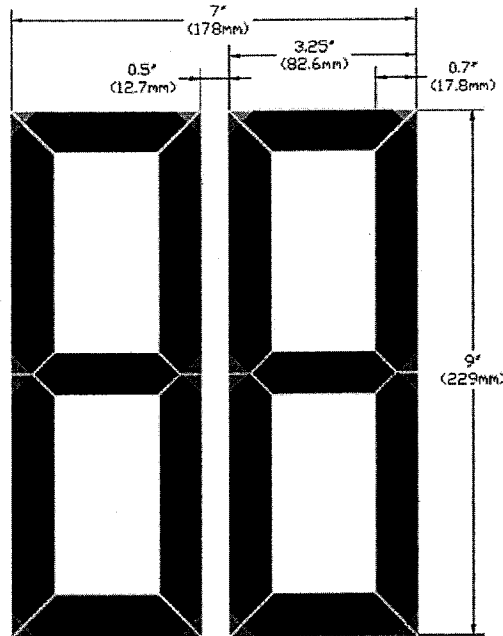

Figure 2: Countdown Display

37. Ped modules shall be repaired or replaced if the ped module fails to function as intended due to workmanship or material defects within warranty period.
38. Ped modules shall be repaired or replaced if the ped module exhibit luminous intensities less than the minimum specified values within 60 months of the date of delivery.
39. The manufacturer shall clearly disclose the country in which the factory of ped module origin is located, the name of the company or organization that owns the factory including all of its parent companies and organizations, and their respective country of corporate citizenship.

S. Pedestrian, Bicycle and Equestrian Push Buttons

Pedestrian, bicycle, and equestrian push buttons shall conform to the provisions in Section 86-5.02, "Pedestrian Push Button Assemblies", of the Standard Specifications and these Special Provisions.

Push button assembly shall be Type B per Standard Plans ES-5C.

Push button housing shall be die-cast or permanent mold cast aluminum powder coated frame with stainless steel inserts and sign screws.

Push button sign shall be white powder coat base with black heat cured ink. Right and left arrow signs shall be doubled sided.

Push button shall be Polara Engineering, Inc. model BDLM2-Y or approved equal.

Push button shall utilize solid-state Piezo switch technology, pressure activated, two-tone audible, visual LED confirmation of actuation and shall be ADA compliant.

The equestrian push buttons (EPB) shall be installed at 6 feet above finish grade or as directed by the Engineer. The Engineer shall approve the EPB placement on each pole prior to installation.

T. Detectors

Detectors shall conform to the provisions in Section 86-5, "Detectors", of the Standard Specifications and these Special Provisions.

Delay timers shall delay calls only during display of the associated red or yellow indications. If a vehicle departs the area of detection prior to expiration of the assigned delay period, the timer shall reset and no call shall be placed upon the controller. During display of the associated green indication, detectors shall operate in the present mode and calls shall not be delayed.

Inductive Loops

Detector loop configuration shall be Type E per Standard Plans ES-5B unless otherwise shown on the construction plan, in the Special Provisions, or as directed by the Engineer.

Limit Line detector loop configuration shall be modified Type E with diagonal saw cuts and wire winding conforming to Type D loop configuration.

Detector loop wire shall be Type 2.

Detector loop lead in cable shall be Type B.

Detector loop curb terminations shall be Type A in accordance with Standard Plans ES-5D.

Loop sealant shall be the Hot-Melt Rubberized Asphalt sealant type, unless otherwise directed by the Engineer. Loop conductors and sealant shall be installed on the same day the loop slots are cut.

All detector loops shall be tested sequentially by the following methods:

- impedance (measured by megaohms)
- resistance (measured by ohms)
- inductance (measured in microhenries)

Video Detection

The contractor shall furnish and install video detection cameras (VDC), video detection processors (VDP), extension modules (EM), access module (AM), an industry standard 3-button USB mouse, a drawer mounted 17 inch LCD monitor, surge suppressors, and all necessary cabling and auxiliary equipment to make the video detection systems fully functional for the intended operation. The Contractor shall furnish an advanced lens adjustment module (LAM), a spare VDC, a spare EM, and a spare VDP to the Engineer.

All equipment supplied shall come from and qualified by the VDP supplier to ensure proper system operation.

The VDC shall attach to the top of luminaire mast arm using mounting bracket provided by manufacturer, or the backside of signal mast arm using Pelco Astrobrac with 6' extension or approved equal. The Engineer shall approve the final camera placements.

The video detection systems shall be installed by supplier factory certified installers per recommended method provided in the supplier's installation manuals. Proof of factory certification shall be provided.

Video Detection Zones:

Placement of detection zones shall be done by using the supplied USB mouse connected to the VDP. Detection zones are drawn on the video image from the video camera displayed on a video monitor using the menu and graphical interface built into the VDP. The menu shall facilitate placement of detection zones and setting of zone parameters or to view system parameters.

Detection zone setup shall not require site-specific information such as latitude, longitude, date and time to be entered into the system. No separate computer shall be required to program the detection zones.

Each detection zone shall be user definable in size and shape to suit the site and the desired vehicle detection region. A detection zone shall be approximately the width and length of one car.

A single detection zone shall be able to replace multiple inductive loops and the detection zones shall be OR'ed as the default or may be AND'ed together to indicate vehicle presence on a single phase of traffic movement.

The VDP shall provide a minimum of 24 channels of vehicle presence detection/detection zones per camera through a standard detector rack edge connector and one or more EMs.

The Video Detection System shall be in compliance with California State Assembly Bill 1581. The system will be able to discriminate between bicycles and automobiles and be able to send bicycle and vehicle actuations from the same lanes to different detection outputs. Additionally the system shall allow an extension time for bicycles that will not apply to vehicular traffic.

Functional Capabilities:

System must have a single point access to multiple rack-mounted video detection units. The access device shall provide interface capabilities to enable multiple rack-mounted video detection processors to be locally and remotely accessed from a single point via one set of user interface devices.

The camera shall be able to transmit the composite video signal, with minimal signal degradation, up to 1000 feet under ideal conditions.

The EM shall be plugged into the appropriate slot in the detector rack to avoid the need of rewiring the detector rack. The extension module shall be connected to the VDP by an 8-wire cable with modular connectors.

The EM and VDP communications shall be accommodated by methods using differential signals to reject electrically coupled noise. The EM shall be available in both 2 and 4 channel configurations programmable from the VDP.

The VDP shall have video input in NTSC composite video format and shall be digitized and analyzed in real time.

The VDP shall have a nine-pin RS232 port that is multi-drop compatible for communications with an external computer. The VDP shall be able to accept new detector patterns from and send its detection patterns to an external computer through this RS-232 port. A Windows™ based

software designed for local or remote connection for uploading and downloading data, and providing video capture, real-time detection indication and detection zone modification capability shall be provided with the system.

The VDP shall store up to three different detection zone patterns within the VDP memory. The VDP's memory shall be non-volatile to prevent data loss during power outages. The VDP shall continue to operate (e.g. detect vehicles) using the existing zone configurations even when the operator is defining/modifying a zone pattern. The new zone configuration shall not go into effect until the operator saves the configuration. Each configuration can be uniquely labeled for identification and the current configuration letter is displayed on the monitor. The selection of the detection zone pattern for current use shall be done through a local menu selection or remote computer via RS-232 port. It shall be possible to activate a detection zone pattern for a camera from VDP memory and have that detection zone pattern displayed within 1 second of activation.

The VDP shall provide dynamic zone reconfiguration to enable normal detector operation of existing channels except the one where a zone is being added or modified during the setup process. The VDP shall output a constant call on any detection channel corresponding to a zone being modified.

The VDP shall detect vehicles in real time as they travel across each detector zone.

The VDP shall output a constant call for each enabled detector output channel if a loss of video signal occurs. The VDP shall output a constant call during the background learning period. The background learning period shall be not more than three minutes.

The VDP shall be capable of detecting a low-visibility condition automatically, such as fog, and place all defined detection zones in a constant call mode. The VDP shall automatically revert to normal detection mode when the low-visibility condition no longer exists. A user-selected output shall be active during the low-visibility condition that can be used to modify the controller operation if connected to the appropriate controller input modifier(s).

Detection shall be at least 98% accurate in good weather conditions and at least 96% accurate under adverse weather conditions (rain, snow, or fog). Detection accuracy is dependent upon site geometry; camera placement, camera quality and detection zone location, and these accuracy levels do not include allowances for occlusion or poor video due to camera location or quality.

Detection zone outputs shall be configurable to allow the selection of presence, pulse, extend, and delay outputs. Timing parameters of pulse, extend, and delay outputs shall be user definable between 0.1 to 25.0 seconds.

Up to six detection zones shall be capable to count the number of vehicles detected. The count value shall be internally stored for later retrieval through the RS-232 port. The data collection interval shall be user definable in periods of 5, 15, 30 or 60 minutes.

System software shall

- Utilize a dual redundant hybrid tracking algorithm to enhance vehicle presence detection and data collection.
- Include a moving shadow and occlusion rejection algorithm that is activated by selection of a drop down menu tab.
- Include a menu selectable zone type labeled "Bike" that is specifically designed to detect bicycles.
- Include a virtual QWERTY keyboard that is present when performing any labeling functions for the detection zones and cameras.

- Include the ability to copy completed zones with one mouse click, drag and drop single zones, rows of zones together and entire detection configurations.

VDP & EM Hardware:

The VDP and EM shall be specifically designed to mount in a standard NEMA TS-1, TS-2, 2070 ATC, 170 type detector rack, using the edge connector to obtain power and provide contact closure outputs. No adapters shall be required to mount the VDP or EM in a standard detector rack. Detector rack rewiring shall not be required or shall be minimized.

Both VDP and EM shall operate in a temperature range from -34°C to +74°C and a humidity range from 0% RH to 95% RH, non-condensing.

Both VDP and EM shall be powered by 12 or 24 volts DC. These modules shall automatically compensate for the different input voltages.

Both VDP and EM shall include detector output pin out compatibility with industry standard detector racks.

Both VDP and EM shall have a detector test switch on the front panel to allow the user to place calls on each channel. The test switch shall be able to place either a constant call or a momentary call depending on the position of the switch.

The VDP power consumption shall not exceed 300 milliamps at 24 VDC. The EM power consumption shall not exceed 120 milliamps at 24 VDC.

The VDP shall utilize flash memory technology to enable the loading of modified or enhanced software through the RS232 port without modifying the VDP hardware.

The VDP shall include the following on the front panel:

- A multi-drop compatible RS232 port, a 9-pin "D" subminiature connector, for serial communications with a remote computer.
- Detection indication such as LED for each channel of detection that display detector outputs in real time when the system is operational.
- One or two BNC video input connection suitable for RS170 video inputs as required. The video input shall include a switch selectable 75-ohm or high impedance termination to allow camera video to be routed to other devices, as well as input to the VDP for vehicle detection. Video must be inputted via a BNC connector on the front face of the processor. RCA type connectors/jacks for video input are not allowed. Video shall not be routed via the edge connectors of the processor.
- One BNC video output providing real time video output that can be routed to other devices. A RCA type connector/jack for video output is not allowed.

Video Detection Camera:

The camera shall be housed in a weather-tight sealed enclosure consists of the following:

1. The enclosure shall be made of 6061 anodized aluminum.
2. The enclosure shall be field rotatable to allow proper alignment between the camera and the traveled road surface.
3. The enclosure shall be equipped with a sunshield. The sunshield shall include a provision for water diversion to prevent water from flowing in the camera's field of view. The camera enclosure with sunshield shall be less than 6" diameter, less than 18" long, and shall weigh less than 6 pounds when the camera and lens are mounted inside the enclosure.
4. The enclosure shall be design so that the pan, tilt and rotation of the camera assembly can be accomplished independently without affecting the other settings.

5. The enclosure shall include a proportionally controlled Indium Tin Oxide heater design that maximizes heat transfer to the lens. The output power of the heater shall vary with temperature, to assure proper operation of the lens functions at low temperatures and prevent moisture condensation on the optical faceplate of the enclosure.
6. The glass face on the front of the enclosure shall have:
 - a. An anti-reflective coating to minimize light and image reflections.
 - b. A special coating to minimize the buildup of environmental debris such as dirt and water.

The camera shall produce a useable video image of the bodies of vehicles under all roadway lighting conditions, regardless of time of day. The minimum range of scene luminance over which the camera shall produce a useable video image shall be the minimum range from nighttime to daytime, but not less than the range 1.0 lux to 10,000 lux.

The imager luminance signal to noise ratio shall be more than 50 dB. In harsh backlit conditions, vehicles can be detected flawlessly with >100dB of dynamic range.

The camera shall be digital signal processor based and shall use a CCD sensing element and shall output color video with resolution of not less than 540 TV lines. The CCD imager shall have a minimum effective area of 811(h) x 508(v) pixels.

The camera shall include an electronic shutter control based upon average scene luminance and shall be equipped with an auto-iris lens that operates in tandem with the electronic shutter.

The camera shall utilize automatic white balance.

The camera shall include a variable focal length lens with variable focus that can be adjusted, without opening up the camera housing, to suit the site geometry by means of a portable interface device designed for that purpose and manufactured by the detection system supplier.

The horizontal field of view shall be adjustable from 5.4 to 50.7 degrees. This camera configuration may be used for the majority of detection approaches in order to minimize the setup time and spares required by the user. The lens shall have a 27x zoom.

The lens shall also have an auto-focus feature with a manual override to facilitate ease of setup.

The camera shall incorporate the use of preset positioning that store zoom and focus positioning information. The camera shall have the capability to recall the previously stored preset upon application of power.

The camera electronics shall include automatic gain control to produce a satisfactory image at night.

When mounted outdoors in the enclosure, the camera shall operate satisfactorily in a temperature range from -34 °C to +60 °C and a humidity range from 0% RH to 100% RH. Measurement of satisfactory video shall be based upon VDP system operation.

The camera shall be powered by 120-240 VAC 50/60 Hz. Power consumption shall be 30 watts or less under all conditions.

The camera shall view approaching vehicles at a distance not to exceed 350 feet for reliable detection (height to distance ratio of 1:10). Camera placement and field of view shall be unobstructed and as noted in the installation documentation provided by the supplier.

There shall be at least 2 options for camera set up, diagnostic testing, and viewing video when it is mounted on mast arm or pole using lens adjustment module supplied by the VDP supplier:

1. Connected directly to the camera.

2. Connected to the coaxial cable from the cabinet.

The video signal shall be fully isolated from the camera enclosure and power
Cable terminations at the camera for video and power shall not require crimping tools.

No BNC or other connector shall be used for the coaxial video cable termination at the camera.

The power connection at the camera shall use connector terminations that only require the use of wire strippers and a standard screwdriver. No special crimping tools or other types of terminations shall be used.

A weather-proof protective cover shall be provided shall be provided to protect all terminations at the camera. No special tooling shall be required to remove or install the protective cap.

Cabling and Cable Connections:

The coaxial cable to be used between the camera and the VDP in the traffic cabinet shall be Belden 8281. The coax cable shall be a continuous unbroken run from the camera to the VDP. This cable shall be suitable for installation in conduit or overhead with appropriate span wire. A BNC plug connector shall be used at the cabinet end. The coaxial video cable shall be stripped and terminated at the camera and cabinet per manufacturers' instructions (no BNC or other connector shall be used at the camera). The coaxial cable, BNC connector used at the cabinet termination, and crimping tool shall be approved by the supplier of the video detection system and the manufacturer's instructions must be followed to ensure proper connection.

The power cable shall be three 16 AWG conductor cable with a minimum outside diameter of 0.325 inch and a maximum diameter of 0.490 inch. The power cable shall be terminated at the camera per manufacturers' instructions and shall only require standard wire strippers and a screw driver for installation (no special connectors or crimping tools shall be used for installation). The cabling shall comply with the National Electric Code, as well as local electrical codes. Cameras shall not acquire power from the luminaire.

A Din Rail mounted AC power panel assembly shall be supplied by the video detection manufacturer that will include a minimum of one convenience receptacle, four camera chassis ground connections, four camera AC neutral (AC-) connections, four 2 amp camera circuit breakers for hot (AC+) connections, and one AC source connection for Line, Neutral and Ground wires. A Din Rail video surge suppression protection panel assembly shall also be supplied by the video detection manufacture. One panel shall accommodate up to six EDCO surge suppressors. This equipment shall be installed, including termination of all necessary wiring, per the video detection manufacturer requirements for the intended use.

Maintenance and Support:

The supplier shall maintain an adequate inventory of parts to support maintenance and repair of the system. These parts shall be available for delivery within 30 days of placement of an acceptable order at the supplier's then current pricing and terms of sale for said parts.

The supplier shall maintain an ongoing program of technical support for the access unit and video detection system. This technical support shall be available via telephone, or via personnel sent to the installation site upon placement of an acceptable order at the supplier's then current pricing and terms of sale for on-site technical support services.

Installation or training support shall be provided by factory-authorized representative.

All product documentation shall be written in the English language.

U. Luminaires

Luminaires shall conform to the provisions in Section 86-6, "Lighting", of the Standard Specifications and these Special Provisions.

Luminaires shall be of the cutoff type and shall be 200, 250 or 400 Watt High Pressure Sodium Vapor as shown on the plans. The fixtures shall be constructed with flat lenses, integral ballasts, and detachable power unit assemblies. The power unit assemblies shall contain the ballast, starter board, capacitors, and a heavy-duty terminal block.

Each luminaire shall be furnished without the photoelectric unit receptacle.

Each luminaire shall have a 5-amp inline fuse installed inside the standard's hand hole.

V. Internally Illuminated Street Name Signs

Internally illuminated street name signs (IISNS) shall conform to the provisions in Section 86 6.09, "Internally Illuminated Street Name Signs", of the Standard Specifications and these Special Provisions.

The sign fixture, panels, and mounting assemblies shall be designed and constructed to prevent deformation, warp or failure when subjected to a minimum of 100 mph wind loads, as set forth in the latest AASHTO publication, "Standard Specifications for Structural Supports of Highway Signs, Luminaires, and Traffic Signals", and amendments thereto. The IISNS manufacturer shall submit a certificate of compliance conforming to the provisions in Section 6-3.05E , "Certificates of Compliance", with each lot of IISNSs delivered.

The IISNS shall be double-faced Edge-lit LED sign with white translucent diamond grade reflective border, arrows, and lettering using 12" uppercase and 9" lowercase Clearview Series 5-W fonts. The background shall be green match color no. 14109 of FED-STD-595.

The standard IISNS height shall be 2' and length shall be 6', 8' or 10' attached to the 10 feet IISNS mast arm with Pelco SE-5015 mast arm sign bracket, or approved equal, per County Standard No. 1200.

W. Photoelectric Controls

Photoelectric controls shall conform to the provisions in Section 86-6.11, "Photoelectric Controls", of the Standard Specifications and these Special Provisions.

Photoelectric controls shall be a dual Type V for luminaires and internally illuminated street name signs conforming to the County Standard No. 1207.

Photoelectric units shall be the delay type.

X. Emergency Vehicle Preemption System

Furnish and install complete and functioning emergency vehicle preemption (EVP) system as intended per plans, the manufacturer, and these special provisions.

The EVP system shall consist of the following equipments or components:

- Optical detector for each approach, as shown on the plans
- Rack-mounted 4-channel phase selectors for 8-phase operation
- Detector cable

The Contractor shall furnish the following spare EVP equipments or components:

- One (1) rack-mounted 4-channel phase selector
- One (1) optical detector

The EVP system shall be designed to prevent simultaneous pre-emption by two or more emergency vehicles on separate approaches to the intersection.

The Engineer shall approve EVP sequence of operation prior to timing and turn-on of each respective traffic signal.

At locations where optical detectors are not to be installed, EVP cable shall be installed for future use. The following also apply:

1. EVP cable shall be installed, without splices, between the controller cabinet and each mast arm traffic signal pole.
2. EVP cable shall be connected to the EVP rack terminals within the controller cabinet.
3. Each mast arm EVP detector mounting shall be drilled and tapped in its ultimate location. In lieu of the detector, install approved water tight UL listed electrical box. EVP cable shall be installed to terminate within the mast arm mounted electrical box. Excess cable shall be coiled within the electrical box sufficient for future installation of the EVP system.

Optical Detector

The optical detector shall be mounted on the indicated signal mast arm per County Standard No. 1202.

Each optical detector shall be waterproof unit capable of receiving optical energy from dual directions and have an adjustable turret configuration. The reception angle for each optical detector unit shall be a minimum of eight (8) degrees in all directions about the aiming axis of the unit.

Dual detectors shall utilize only one optical cable per detector.

Internal circuitry shall be solid state and electrical power shall be provide by the associated discrimination module.

Each optical detector unit shall have a minimum of a 3/4 inch NPT opening used for mounting and for bringing the connecting cable into the terminal block located within the assembly. The housing shall be provided with weep holes to permit drainage of condensed moisture.

Each optical detector shall be installed, wired, and aimed as specified by the manufacturer.

Cable

Optical detector cable shall meet the requirements of IPCEA-S-61-402/NEMA WC 5, Section 7.4, 600 V Control cable, 75 degrees C, Type B, and the following:

1. The cable shall contain 3 conductors, each of which shall be AWG# 20 (7 x 28) stranded, tinned copper. Insulation of individual conductors shall be color-coded: 1-Yellow, 1-Orange, and 1-Blue.
2. The shield shall be either tinned copper braid or aluminized polyester film with a nominal 20% overlap. When film is used, an AWG# 20 (7 x 28) stranded, tinned, bare drain wire shall be placed between the insulated conductors and the shield and in contact with the conductive surface of the shield.
3. The jacket shall be marked as required by IPCEA/NEMA.

The cable run between each detector and the Traffic Controller cabinet shall be continuous without splices.

Phase Selector

Each phase selector shall be compatible and usable with a Model 170E or 2070 controller unit, and shall be mounted in the input file of a Model 332 or Model 333 JP controller cabinet.

Each phase selector shall be capable of operating at least two or more channels, each of which shall provide an independent output for each separate input.

Phase Selector shall be a four-channel, dual priority, Multimode encoded signal device designed for use with both infrared and GPS emitters and optical detectors.

Phase Selectors and Optical detectors shall be manufactured by a single manufacturer

Phase Selector shall recognize and discriminate among three distinct frequency rates via high priority, low priority and probe priority infrared and GPS signals.

Phase selector shall further discriminate among 254 agency ID's, 15 classes of vehicle identification codes and 10,000 individual vehicle codes per class, for more than 38 million total per priority level.

Phase selector shall be capable of operating unlimited intersections and directions.

Phase selector shall have on the front panel, USB, serial and Ethernet capabilities

Phase selector shall be capable of accepting infrared signals from LED and or strobe technologies

Phase selector shall store the following records:

- Intersection name
- Date and time of activity
- Vehicle class and code of activating vehicle
- Activating vehicle's ID number
- Agency ID
- Channel called
- Priority of the activity
- Final green activity displayed at end of call
- Time spent in the final greens
- Duration of the activity
- Turn signal status
- Relative priority level
- Capability to playback up to the last 250 seconds of the 100 most recent calls

Each phase selector, when used with its associated optical detectors, shall perform as a minimum, the following:

1. Receive Class I and Class II signals.
2. Decode the signals based on optical frequency, at 9.639 Hz + or -0.119 Hz for Class I signals and 14.035 Hz + or -0.255 Hz for Class II signals.
3. Establish the validity of received signals based on optical frequency and length of time received. A signal shall be considered valid only when received for more than 0.50 second. No combination of Class I signals shall be recognized as a Class II signal regardless of the number of signals being received, up to a maximum of 10 signals. Once a valid signal has been recognized, the effect shall be held by the module, in the event of temporary loss of signal for a minimum period of 4.0 seconds.

4. Provide an output for each channel that will result in a "low" or grounded condition of the appropriate input of a Model 170 controller unit. For a Class I signal, the output shall be a 6.25 Hz + or - 0.1 %, rectangular waveform with a 50 % duty cycle. For Class II signal, the output shall be steady.

Each phase selector shall receive power from the controller cabinet at either 12 VDC or 120 VAC.

Auxiliary inputs for each channel may enter each module through a front panel connector or by a parallel hook-up of the associated detector cables at the input location.

The phase selector shall provide an optically isolated output for each channel to the Model 170 controller unit. All outputs signals shall comply with NEMA signal level definitions and shall be compatible with the Model 170 controller assemblies' inputs.

Each phase selector shall be provided with means of preventing transients received by the detector from affecting the Model 170 controller assembly.

Each phase selector shall have a single connector board and shall occupy one slot of the input file. The front panel of each phase selector module shall have a handle to facilitate withdrawal and have the following controls and functions for each channel:

1. Range adjustments for both class I and Class II signals.
2. A 3-position, center off, momentary contact switch, one position (down) labeled for test operation of Class I signals, and one position (up) labeled for test operation of Class II signals.
3. A "signal" indication and a "call" indication each for Class I and for Class II signals. The "signal" indications denote that a signal, which is not valid, has been received; a "call" indication denotes a steady, valid signal has been received. These 2 indications may be accomplished with a single indication lamp.

In addition, the front panel shall be provided with additional connectors or ports used to perform other functions as specified by the manufacturer.

Cabinet Wiring

Wiring for a Model 332 cabinet shall conform to the following:

1. Slots 12 and 13 of input file "J" shall be wired to accept either a 2 channel or a 4 channel module.
2. Field wiring for the primary detectors, except the 24 VDC power, shall terminate on either terminal block TB-9 in the controller cabinet or on the rear of input file "J", depending on cabinet configuration. Where TB-9 is used, position assignments shall be as follows:
 - a. TB-9 - 1 = Not Used
 - b. TB-9 - 2 = + 24 VDC Out (Orange)
 - c. TB-9 - 3 = + 24 VDC Out (Orange)
 - d. TB-9 - 4 = EVA Detector (Yellow)
 - e. TB-9 - 5 = EVC Detector (Yellow)
 - f. TB-9 - 6 = DC Common Out (Blue)
 - g. TB-9 - 7 = EVB Detector (Yellow)
 - h. TB-9 - 8 = EVD Detector (Yellow)
 - i. TB-9 - 9 = DC Common Out (Blue)

Assuming TB9 – 2 and TB9 – 3 are unused on the “J” File, move wires on J11-J & J11-K (Twisted Pair) to J12-E & J13-E, respectively.

Field wiring for auxiliary detectors may terminate on terminal board TB-0 (If unused) in the controller cabinet. Use manufactures recommended wiring for these connections.

System Operation

The contractor shall demonstrate that the components of each system are compatible and will perform satisfactorily as a system. Satisfactorily performance shall be determined using the following test procedure during the functional test period:

1. Each system to be used for testing shall consist of an optical detector, an optical detector cable and a phase selector module.
2. The phase selector shall be installed in the proper input file slot of the Model 332 or 333 controller cabinet assembly.
3. Two tests shall be conducted; one using a Class I signal emitter and a distance of 1000 feet between the emitter and the detector, the other using a Class II signal emitter and a distance of 1800 feet between the emitter and the detector. Range adjustments on the phase selector shall be set to “Maximum” for each test.
4. During the tests of the Class I and Class II emitters, the proper response from the Model 170E and 2070 controller unit during the “ON” interval and there shall be no improper operation of the Model 170E or 2070 controller unit or the monitor during the “OFF” interval.

Arrange for a technician from the EVP manufacturer, to be present for the first day of the traffic signal and lighting function test to insure proper installation and functioning of the EVP equipment.

Arrange for a technician from the controller assembly manufacturer to perform any controller modifications required for the installation, or operation, of the EVP equipment.

Y. GPS Universal Time Sources

The GPS Universal Time Source shall be a McCain model M32755 or approved equal. The Engineer shall approve any alternate GPS time source prior to installation.

The GPS Universal Time Source shall incorporate a precision GPS receiver and a microprocessor to decode the time signals received from the GPS satellite network. The Universal Time Source shall interface this time signal to a model 170E controller (using Bi-Tran local software) to provide an accurate clock update to the traffic signal controller.

The GPS Universal Time Source shall meet or exceed the following criteria:

- Operate in temperatures from –30°C to +80°C.
- Receive power through 170E controller’s ACIA port.
- Provide 170E controller with the time, date, and day of the week data.
- Software configured time zone and daylight savings operations.
- Support RS-232C serial data rates at 300, 600, 1200, 2400, 48000, 9600 and 19200 bps.
- Provide LED indicators for communication status to a satellite.
- Provide a weatherproof disc antenna no greater than 3” diameter x 1” height to be mounted directly to the top of the traffic signal controller cabinet.
- Provide all cabling and connectors with the correct pin assignments to interface the GPS unit to antenna and to 170E controller.

Proper gaskets or other weatherproofing materials for the antenna shall be supplied and installed to prevent water or moisture from entering the traffic signal controller cabinet.

Z. Battery Backup System

This special provision establishes the minimum requirements for a battery backup system (BBS) that shall provide power to a traffic signal system in the event of a power failure or interruption.

The BBS shall be designed for outdoor applications, in accordance with the current edition of Chapter 1, Section 8 requirements of Transportation Electrical Equipment Specifications (TEES).

The BBS batteries shall be external to the traffic signal controller cabinet as specified under "External Battery Cabinet Option" herein unless specified otherwise.

BBS cabinet shall be listed on the current Caltrans pre-qualified product list. The BBS shall include, but not limited to the following:

- cabinet,
- utility line/generator switch,
- inverter/charger,
- power transfer relay,
- a separate manually operated non-electronic bypass switch,
- batteries,
- all necessary hardware, shelving, and interconnect wiring.

The following figure shows BBS components interconnecting with each other and the controller cabinet to ensure interchangeability between all BBS manufacturers.

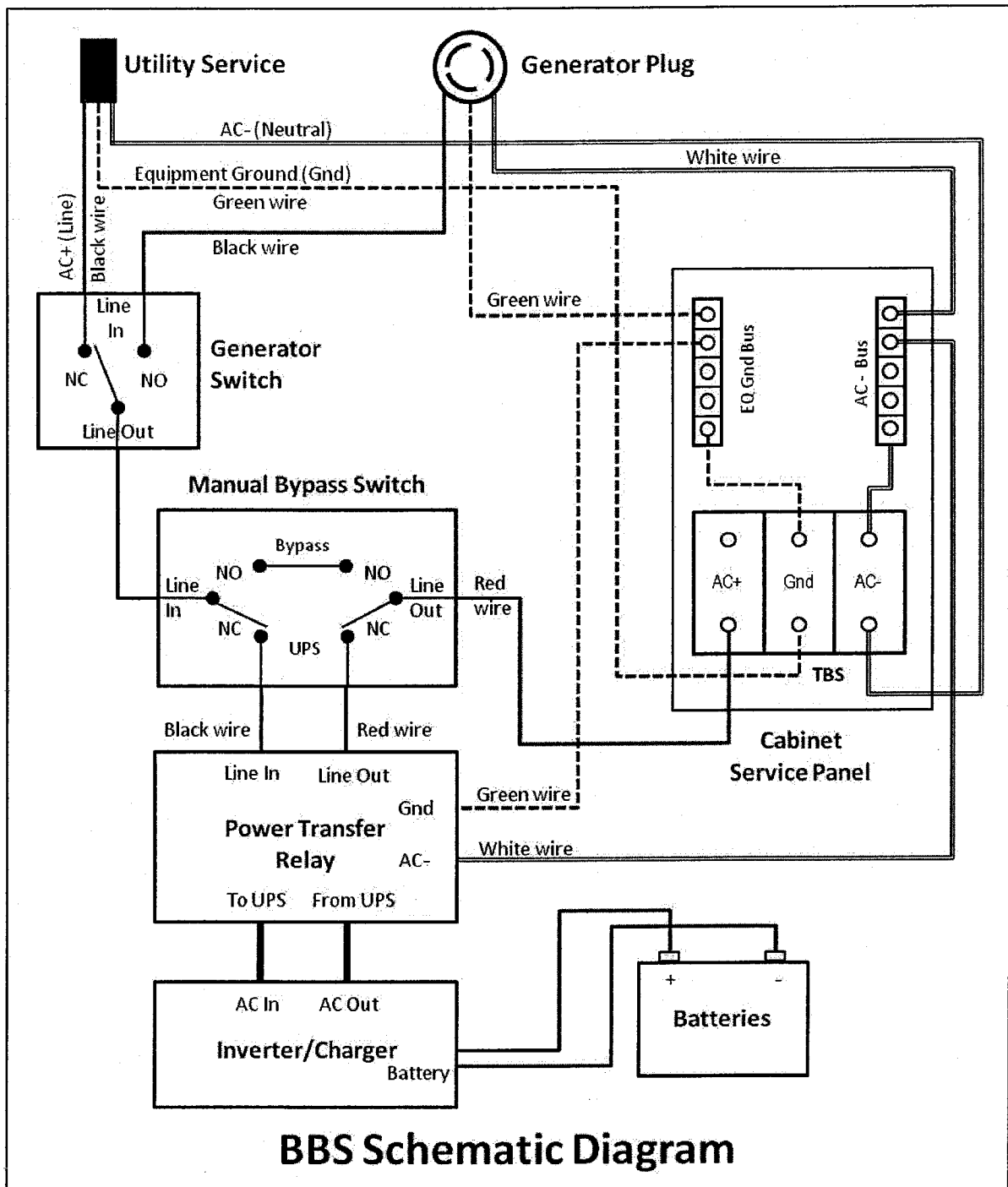

BBS Schematic Diagram

Operation

The BBS shall provide a minimum two (2) hours of full run-time operation for an intersection equipped with all LED traffic signal indications (minimum 1100W active output capacity, with 80% minimum inverter efficiency), and 2 (2) hours of flashing operation.

The maximum transfer time allowed, from disruption of normal utility line voltage to stabilized inverter line voltage from batteries, shall be 65 milliseconds. The same maximum allowable transfer time shall also apply when switching from inverter line voltage to utility line voltage.

The BBS shall provide the user with six (6)-sets of fully programmable normally open (NO) and normally closed (NC) single-pole double-throw (SPDT) dry relay contact closures, available on a panel-mounted terminal block, rated at a minimum 120V/1A, and labeled so as to identify each contact. See below figure for typical configuration.

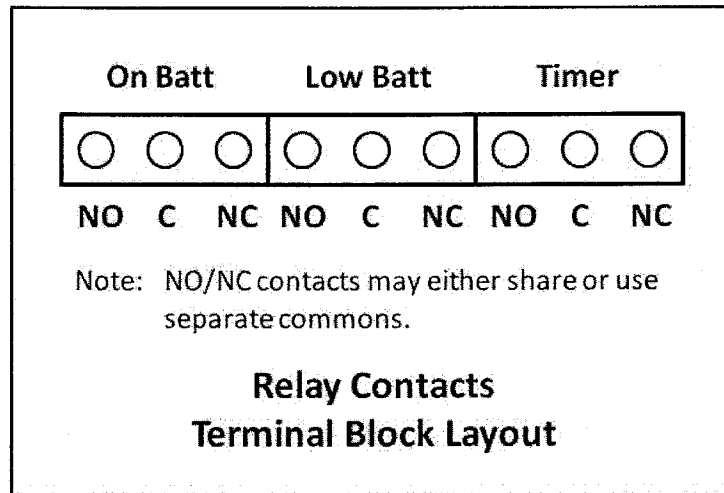

The first set of NO and NC contact closures shall be energized whenever the unit switches to battery power. Contact shall be labeled or marked "On Batt".

The second set of NO and NC contact closures shall be energized whenever the battery approaches approximately 40% of remaining useful capacity. Contact shall be labeled or marked "Low Batt".

The third set of NO and NC contact closures shall be energized two hours after the unit switches to battery power. Contact shall be labeled or marked "Timer".

The six programmable NO and NC contact closures shall be independently configured to activate under any of the following conditions: On Battery, Low Battery, Timer, Alarm, or Fault.

Operating temperature for inverter/charger, power transfer relay and manual bypass switch shall be -37 °C to +74 °C.

Both the Power Transfer Relay and Manual Bypass Switch shall be rated at 240VAC/30 amps, minimum.

The BBS shall use a temperature-compensated battery charging system. The charging system shall compensate over a range of 2.5 – 4.0 mV/ °C per cell.

The temperature sensor shall be external to the inverter/charger unit. The temperature sensor shall come with 10' of wire.

Batteries shall not be recharged when battery temperature exceeds 50 °C ± 3 °C.

BBS shall bypass the utility line power whenever the utility line voltage is outside of the following voltage range: 100VAC to 130VAC (± 2VAC).

When utilizing battery power, the BBS output voltage shall be between 110 VAC and 125 VAC, pure sine wave output, ≤ 3% THD, 60Hz ± 3Hz.

BBS shall be compatible with NEMA and Model 332 and 333JP Cabinets, and Model 170, 390 & 2070 Controllers and cabinet components for full time operation.

In cases of low (below 100VAC) or absent utility line power, when the utility line power has been restored at above 105 VAC \pm 2 VAC for more than 30 seconds, the BBS shall transfer from battery backed inverter mode back to utility line mode.

In cases of high utility line power (above 130VAC), when the utility line power has been restored at below 125VAC \pm 2 VAC for more than 30 seconds, the BBS shall transfer from battery backed inverter mode back to utility line mode.

The BBS shall have an automatic tap to step up or step down the output voltage by 10 percent. The resulting output voltages shall remain within the above prescribed voltage range: 100VAC to 130VAC. This capability will extend BBS range for operating on input AC and not reverting to battery power.

BBS shall be equipped to prevent a malfunction feedback to the cabinet or from feeding back to the utility service.

In the event of inverter/charger failure, battery failure or complete battery discharge, the power transfer relay shall revert to the NC (and de-energized) state, where utility line power is connected to the cabinet.

Recharge time for the battery, from "protective low-cutoff" to 80% or more of full battery charge capacity, shall not exceed twenty (20) hours.

Mounting / Configuration

Generator Switch, Inverter/Charger, Power Transfer Relay and manually operated Bypass Switch shall fit inside a typical fully equipped traffic signal controller cabinet.

Mounting method inside the 332 and 333JP cabinet shall be shelf-mount, rack-mount or combination of either. Available rack space for front-mounted inside the 332 and 333JP cabinet is 3U or approximately 6 inches.

All interconnect wiring provided between Generator Switch, Inverter/Charger, Power Transfer Relay, Bypass Switch and Cabinet Terminal Service Block shall be no less than 9 feet of UL Style 1015 CSA TEW with the following characteristics:

- AWG Rating: 10 AWG
- Stranding: 105 strands of 10 AWG tinned copper
- Rating: 600 V, 105 °C, PVC Insulation

Relay contact wiring provided for each set of NO/NC relay contact closure terminals shall be 9 feet of UL Style 1015 CSA TEW 18 AWG wire, same ratings as above, except 16 strands of 18 AWG tinned copper.

All necessary hardware for mounting (shelf angles, rack, etc) shall be included in the **contract price paid** for the BBS, and no additional compensation will be allowed therefor.

Internal mounted battery option

(Allowed only if requested on the plans)

The controller cabinet shall be equipped with a generator twist lock flanged inlet receptacle, manual transfer switch and bypass switch.

The twist lock flanged inlet receptacle shall be Hubbell 2615, NEMA L5-30P Twist Lock Flanged Male Inlet Rated for 30A/125VAC or approved equal. Receptacle shall be mounted flush to the cabinet in a weatherproof lift cover plate made of impact-resistant thermoplastic and gray in color.

The bypass switch shall transfer the load, including the UPS to the twist lock inlet receptacle. The manual transfer switch shall be wired to prevent any back feed to the utility service. Both the bypass

switch and manual transfer switch shall be rack mounted independently in the controller cabinet meeting industry standards.

Batteries shall be mounted on swing-tray mounted below the controller shelf. A minimum of six (6) bolts/fasteners shall be used to secure swing-trays to the 332 Cabinet standard EIA 19" rack. All bolts/fasteners and washers shall meet the following requirements:

- Screw type: Pan Head Phillips machine screw
- Size and Thread pitch: 10-32
- Material: 18-8 stainless steel (Type 316 stainless steel is acceptable as an alternate)
- Washer: Use one 18-8 stainless steel flat washer under the head of each 10-32 screw; lock washers are unnecessary provided that the screws are properly tightened.

Number of screws per swivel bracket: minimum six (6) screws per swivel bracket. Screws are to be spaced evenly along bracket, with one screw near each end. Batteries may be shelf mounted in area behind controller so long as shelf and batteries do not interfere with controller unit and C1 plug.

External battery cabinet option

Batteries shall be housed in an external cabinet mounted to the side of the controller cabinet as shown in the following figure or as directed by the Engineer with a minimum of eight (8) bolts:

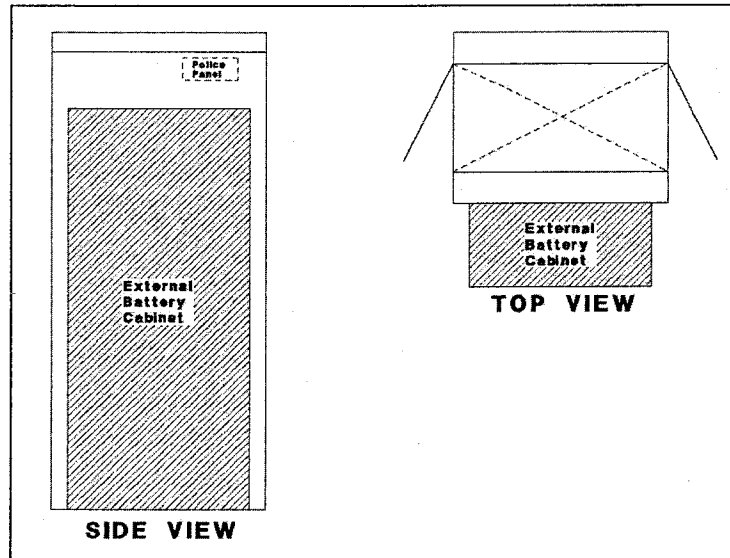

If BBS is installed at the back of controller cabinet, the modification shall include a minimum of 36 inches wide concrete walkway access to the BBS without encroaching outside the right-of-way. BBS shall be installed at the front of the controller cabinet (in locations where the back of the controller cabinet has limited ROW or conflicting structures and facilities and other obstructions), the BBS cabinet shall not cover the police panel. The BBS cabinet shall also not hinder the access ramp's compliance with ADA requirements.

Four shelves shall be provided within the battery cabinet. There shall be a minimum of 12 inches clearance between shelves. Each shelf shall be a minimum of 9" X 25", and capable of supporting a minimum of 125 lbs. Batteries shall be mounted on individual shelves.

The external battery cabinet shall be NEMA 3R rated in accordance to Section 2-Housings of the Chapter 7 of TEES, for the construction of the cabinet and anodic coating finish.

The external battery cabinet shall be ventilated through the use of louvered vents, filter, and one thermostatically controlled fan in accordance to Section 2-Housings of the Chapter 7 of TEES.

External battery cabinet fan shall be AC operated from the same line output of the Manual Bypass Switch that supplies power to the controller cabinet.

The external battery cabinet shall have a door opening to the entire cabinet. The door shall be attached to the cabinet through the use of a continuous stainless steel piano hinge or four, two-bolts per leaf, hinges in accordance to Section 2-Housings of the Chapter 7 of TEES. The door shall use a three-point, roller locking mechanism and standard #2 key lock to lock the door. The door shall have a stainless steel handle.

The external cabinet shall be equipped with a generator twist lock flanged inlet receptacle, manual transfer switch and bypass switch.

The twist lock flanged inlet receptacle shall be Hubbell 2615, NEMA L5-30P, Twist Lock Flanged Male Inlet Rated for 30A/125V or approved equal. Receptacle shall be mounted flush to the cabinet in a weatherproof lift cover plate made of impact-resistant thermoplastic and gray in color.

The bypass switch shall transfer the load, including the UPS to the twist lock inlet receptacle. The manual transfer switch shall be wired to prevent any back feed to the utility service. Both the bypass switch and manual transfer switch shall be rack mounted independently in BBS cabinet meeting industry standards.

The BBS with external battery cabinet shall come with all bolts, conduits and bushings, gaskets, shelves, and hardware needed for mounting.

Maintenance, Displays, Controls and Diagnostics

The BBS shall include a 2 line by 40 character LCD display to indicate current battery charge status, input/output voltages, time and settings of various conditions. The same parameters shall be available via RS232 or USB interfaces on the face of the BBS.

The BBS shall have lightning surge protection compliant with IEEE/ANSI C.62.41.

The BBS shall be capable of accepting firmware upgrades of the non-volatile, read-only memory via serial port communications. The updates shall be accomplished by uploading the software to the BBS over the RS232 serial port located on the face of the BBS.

The BBS shall be equipped with an integral system to prevent battery from destructive discharge and overcharge.

The BBS shall be capable of performing a SELF-TEST, locally from the BBS front panel LCD, or remotely via RS232 or USB interface. The duration of the SELF-TEST shall be programmable in 1-minute increments from 1 minute to 255 minutes.

The BBS and batteries shall be easily replaced with all needed hardware and shall not require any special tools for installation.

The BBS shall include a re-settable inverter event counter to indicate the number of times the BBS was activated and the total number of hours the unit has operated on battery power, accessible via the LCD screen or remotely via RS232 or USB.

The BBS shall be equipped with an event log that stores for a minimum the last 100 events. The events shall be time and date stamped. The event log shall be retrievable vial RS232, USB or from the BBS LCD screen. The event log shall be display and print out in plain English when output the RS232 or USB ports.

Battery System

Individual battery shall be 12V, rated 105 amp-hour for 20 hours @ 77°F to 1.70 VPC, deep cycle, sealed prismatic lead-calcium based Absorbed Glass Mat/ Valve Regulated Lead Acid (AGM/VRLA) battery and shall be easily replaced and commercially available off the shelf.

The manufacturer shall certify batteries to operate over a temperature range of – 25 °C to +74 °C.

The batteries shall be provided with appropriate interconnect wiring and corrosion-resistant mounting trays and/or brackets appropriate for the cabinet into which they will be installed.

Batteries shall indicate maximum recharge data and recharging cycles.

Furnish four (4) batteries for the BBS.

Battery Harness

Battery interconnect wiring shall be via two-part modular harness:

- Part I shall be equipped with red (+) and black (-) cabling that can be permanently connected to the positive and negative posts of each battery. Each red and black pair shall be terminated into a Molex, polarized – keyed battery cable connector or equivalent. The length of the harness between batteries shall be a minimum of 12 inches.
- Part II shall be equipped with the mating Power Pole style connector for the batteries and a single, insulated Power Pole style connection to the inverter/charger unit. Harness shall be fully insulated and constructed to allow batteries to be quickly and easily connected in any order to ensure proper polarity and circuit configuration. The length of the battery interconnect harness shall be a minimum of 60 inches from the Inverter/Charger plug to the first battery in the string.

Power Pole connectors may be either one-piece or two-piece. If a two-piece connector is used, a locking pin shall be used to prevent the connectors from separating.

All battery interconnect harness wiring shall be UL Style 1015 CSA TEW or Welding Style Cable or equivalent, all of proper gauge with respect to design current and with sufficient strand count for flexibility and ease of handling.

Battery terminals shall be covered and insulated with molded boots to prevent accidental shorting.

BBS Quality Assurance

Each Battery Backup System (BBS) shall be manufactured in accordance with a manufacturer Quality Assurance (QA) program. The QA program shall include two Quality Assurance procedures:

1. Design QA - The manufacturer, or an independent testing lab hired by the manufacturer, shall perform Design Qualification Testing on new BBS system(s) offered, and when any major design change has been implemented on an existing design. A major design change is defined as any modification - material, electrical, physical, or theoretical, that changes any performance characteristics of the system, or results in a different circuit configuration. Where a dispute arises in determining if a system is a new design or if the system has had a major design change, the County will make the final determination if Design Qualification Testing is required prior to production consideration.
2. Production QA - The Production QA shall include statistically controlled routine tests to ensure minimum performance levels of BBS units built to meet this specification and a documented process of how problems are to be resolved.

QA process and test results documentation shall be kept on file for a minimum period of seven years.

Battery Backup System designs not satisfying Design QA Testing and Production QA Testing requirements shall not be labeled, advertised, or sold as conforming to this specification.

A technician whom is qualified to work on the battery backup system and employed by the battery backup system manufacturer or the manufacturer authorized distributor, shall be present at the time the equipment is turned on.

It shall be the responsibility of the Contractor to implement and fund any traffic signal controller assembly modifications required to achieve the traffic signal operation as shown on the construction plans and as required in the Special Provisions.

AA. Payment Method

See Signal and Lighting subsection P, "Service" for payment of all electric company fees required.

The contract price paid **per Lump Sum** for Signal and Lighting shall include full compensation for furnishing all labor, materials, tools, equipment, foundations, pole and mast arm mounted regulatory signs, documents, programming, testing, potholing required for utility verification prior to all conduit installation and incidents and for doing all the work specified herein, elsewhere in these Special Provisions, and plans including the complete installation of an operational traffic signal and lighting system and no additional compensation shall be allowed therefor.

Appendix A

AQMD Recommendations

Dust Abatement Attachments

Table of Contents

<u>Description</u>	<u>Page</u>
Signage Recommendation (AQMD document, modified)	DA1
Sample Dust Control Plan (AQMD sample)	DA5
Dust Control Plan Review Checklists (AQMD document)	DA6
Reasonably Available Control Measures (from Rule 403 Implementation Handbook)	DA10
Best Available Control Measures (from Rule 403 Implementation Handbook)	DA16
Best [Reasonably] Available Control Measures for High Winds Conditions (from Rule 403 Implementation Handbook)	DA22
Track Out Control Options (from Rule 403 Implementation Handbook)	DA26

AQMD SIGNAGE RECOMMENDATIONS**November, 2001**

Plan holder shall post signage at specified locations on the subject property in accordance with the standards specified below. The exception to the standards is that all letters shall be 4 inches high, with the names and telephone numbers of appropriate contacts and services in bold print, as indicated in the standards. These signs shall also include the SCAQMD toll free complaint line 1-800-CUT-SMOG (1-800-288-7664) and the telephone number for the Environmental Observer. These signs shall be posted within 50 feet of the curb on all four (4) corners of the subject property.

For each Dust Control Plan aggregating less than, or equal to, ten (10) acres:

1. The applicant shall install a sign on such property which is visible to the public that meets the following requirements:
 - (a) Such sign shall measure at least four (4) feet wide by four (4) feet high and conform to the specifications in 1 (a) below.

For each Dust Control Plan aggregating over ten (10) acres:

2. The applicant shall install a sign on such property which is visible to the public that meets the following requirements:
 - (a) Such sign shall measure at least eight (8) feet wide by four (4) feet high and conform to the specifications in 1 (b) below.

THE SIGN SHALL CONFORM TO THE FOLLOWING REQUIREMENTS:

1. **The sign boards shall be constructed with materials capable of withstanding the environment in which they are placed.**

(a) For 4' x 4' signs, the District recommends the following:

- I. 3/4" A/C laminated plywood board
- II. Two 4" x 4" posts
- III. The posts should be attached to the edges of the plywood board with at least 2 carriage bolts on each post.
- IV. The front surface of the sign board should be painted in the contrasting color of a white background with black lettering.

(b) For 4' x 8' signs, the District recommends the following:

- I. 1" A/C laminated plywood board
- II. Two 5" x 6" posts
- III. The posts should be attached to the 4' edges of the plywood board with at least 2 carriage bolts on each post.
- IV. The front surface of the sign board should be painted in the contrasting color of a white background with black lettering.

2. The sign board shall be installed and maintained in a condition such that members of the public can easily view, access, and read the sign at all times until the expiration date of the Dust Control plan.

(a) For 4' x 4' signs, the District recommends the following:

- I. The lower edge of the sign board should be mounted at least 2' above the existing ground surface to facilitate ease of viewing.
- II. The posts should be set in a hole at least 3' deep with concrete footings to preclude downing by high winds.
- III. On the construction site, the sign should be positioned such that nothing obstructs the public's view from the primary street access point.
- IV. For construction projects that are developed in phases, the sign should be moved to the area that is under active construction.
- V. In situations where all phases of the construction project are completed on a property prior to expiration of the Dust Control Plan, a written request for cancellation of the Dust Control Plan must be submitted to the Engineer.

(b) For 4' x 8' signs, the District recommends the following:

- I. The lower edge of the sign board should be mounted at least 2' above the existing ground surface to facilitate ease of viewing.
- II. The posts should be set in a hole at least 4' deep with concrete footings to preclude downing by high winds.
- III. On the construction site, the sign should be positioned such that nothing obstructs the public's view from the primary street access point.
- IV. For construction projects that are developed in phases, the sign should be moved to the area that is under active construction.
- V. In situations where all phases of the construction project are completed on a property prior to expiration of the Dust Control Plan, a written request for cancellation of the Dust Control Plan must be submitted to the Engineer.

3. The sign board shall contain the following information:

- (a) Project Name
- (b) Name of Prime Contractor
- (c) Phone Number of Contractor's Employee Responsible for Dust Control Matters
- (d) County designated phone number (to be provided by the Engineer)
- (e) South Coast Air Quality Management District Phone Number

4. The sign board shall be designed to the following alpha and numeric text dimensions (sign boards written in longhand are unacceptable).

(a) For a permittee subject to the 4' x 4' sign requirement, the District provides the following example: (as modified by the County of Riverside for use on County Public Works projects)

1" UPPERCASE Letters →	PROJECT NAME:		3 ½" Title Case Bold Letters ←
1" UPPERCASE Letters →	CONTRACTOR		3 ½" Title Case Bold Letters ←
1" Title Case Letters →	Contractor's Dust Control Phone #		3" Bold Numbers ←
1" Title Case Letters →	County of Riverside Phone #		3" Bold Numbers ←
1" Title Case Letters →	Phone Number:	SCAQMD 1-800-CUT-SMOG	3 ½" Bold Numbers ←

"Title Case" means the first letter of a word is capitalized and subsequent letters are lower case.

AQMD Recommendations

(b) For a permittee subject to the 4' x 8' sign requirement, the District provides the following example: (as modified by the County of Riverside)

2" UPPERCASE Letters	PROJECT NAME:	4" Title Case Bold Letters
2" UPPERCASE Letters	CONTRACTOR	4" Title Case Bold Letters
2" Title Case Letters	Contractor's Dust Control Phone #	4" Bold Numbers
2" Title Case Letters	County of Riverside Phone #	4" Bold Numbers
2" Title Case Letters	Phone Number:	4 1/2" Bold Numbers
2" Title Case Letters	<p style="text-align: center;">SCAQMD 1-800-CUT-SMOG</p> <p style="text-align: center;">COUNTY OF RIVERSIDE TRANSPORTATION DEPARTMENT</p>	

QMD Recommendations

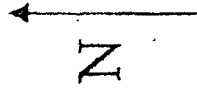

Distance and location of nearest:
 Residence _____
 Business _____

Section 1
Simplified Sample Site Plan

Existing Residential

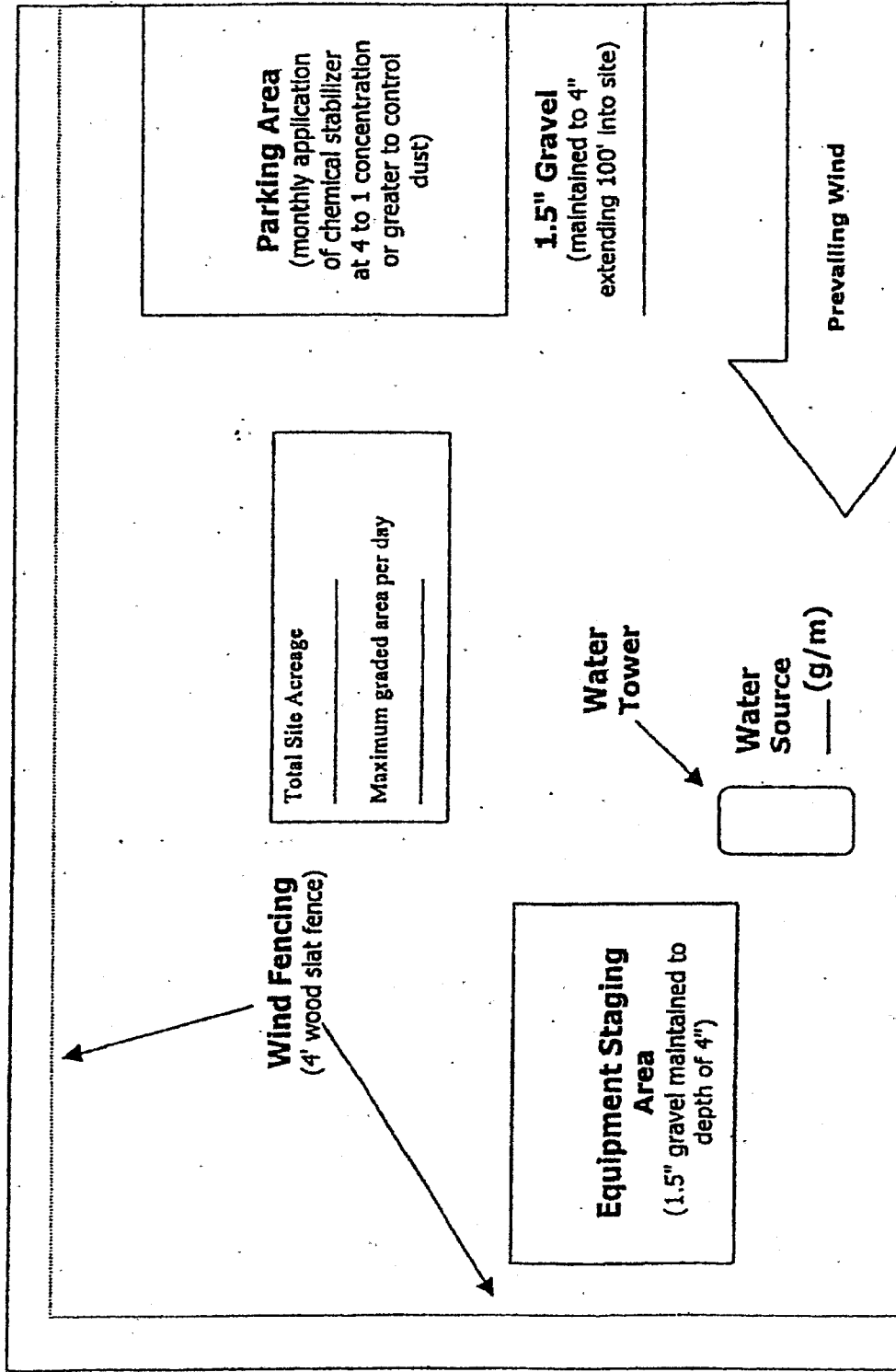

Existing Residential

Existing Residential

Vacant Land

Remember...
DUST CONTROL IS REQUIRED 24 HOURS A DAY, 7 DAYS A WEEK,
REGARDLESS OF CONSTRUCTION STATUS

Plan Review Checklist Clearing/Grubbing/Mass Grading Phase

- If feasible, use grading permit conditions to break the project into phases so that only a portion of the site is disturbed at any given time to ensure control of fugitive dust. This technique is critical for project sites with greater than 100 acres.

- Prior to initiating activity, pre-water site through use of portable irrigation lines. At least 72 hours of pre-watering is recommended for each area prior to initiating earth-movement. Require the Applicant to specify water source and available flow rate (g/m).

Water applied continuously to all disturbed portions of the site by means of water truck/water pull as necessary to maintain sufficient visible moisture on the soil surface. For reference, one 2,000 gallon water truck can treat approximately 4 acres of active construction per hour. Also, for cut and fill activities, one 10,000 gallon water pull is estimated to be necessary for each 7,000 cubic yards of daily earth-movement. Multiple 4,000-gallon water trucks may be used in place of one 10,000-gallon water pull. Touch and visual contrast are reasonably good indicators of soil moisture. Surface areas that are dry to the touch and appear lighter-colored require the application of additional water to prevent visible or fugitive dust. Require the Applicant to specify the number of watering vehicles available for dust control during mass grading and during off-hours as well as availability of back-up water trucks if the site experiences dust control problems.

- Water towers are necessary for projects with more than 10 acres of active construction. Without a water tower, it can take up to 30 minutes to fill a 2,000 gallon water truck. Also, multiple water towers are necessary for projects that use water pulls as filling one 10,000 gallon water pull can drain a water tower which takes up to 40 minutes to refill.

- Wind fencing is necessary between the site and nearby residences or businesses. Off-site upwind fencing and on-site wind fencing for larger projects can also keep blowsand from being deposited onto the site or traveling through the site.

- A perimeter watering system consisting of portable irrigation equipment may be an effective mitigation system to protect surrounding residences and businesses. The portable watering system may be used in place of or in conjunction with watering trucks. The local jurisdiction may also be provided access to this equipment.

Remember...

**DUST CONTROL IS REQUIRED 24 HOURS A DAY, 7 DAYS A WEEK,
REGARDLESS OF CONSTRUCTION STATUS**

- Construction site accesses are to be improved with 1.5" gravel maintained to a depth of 4" , at least 20' wide, and extending 100 feet into the site. If the project site is not balanced, a wheel washing system and/or ribbed steel plates should be placed in the roadway before the vehicle enters the graveled area to clean the tires and prevent trackout.
- Equipment staging areas are to be treated with 1.5" gravel maintained to a depth of 4".
- Employee parking areas are to be covered with 1.5" gravel maintained to a depth of 4" or treated with chemical dust suppressants at a 4 to 1 ratio on at least a monthly basis to prevent fugitive dust.
- Chemical dust suppressants are to be mixed at a ratio of 20 to 1 and applied to all disturbed surfaces that are proposed to remain inactive for a period of at least 10 consecutive days. These products are effective in preventing and controlling dust. Recordkeeping is necessary to demonstrate compliance.
- All project sites greater than 100 acres shall monitor daily wind speeds and AQMD forecasted wind events (call 1.800.CUT.SMOG, press one for air quality information, and then press five for Coachella Valley wind forecasts). Operators shall maintain these records for review by any local code enforcement officer or AQMD inspector.
- An environmental observer whose primary duty is to oversee dust control at the site is to be used for construction projects greater than 100 acres and/or sites with more than 50 acres of active construction. The environmental observer is tasked with monitoring dust abatement measures and authorized to deploy additional water trucks and other dust control actions (i.e., wind fencing, street sweepers, chemical dust suppressants, etc.) as necessary to prevent or control fugitive dust.
- Other (specify): _____

Remember...
DUST CONTROL IS REQUIRED 24 HOURS A DAY, 7 DAYS A WEEK,
REGARDLESS OF CONSTRUCTION STATUS

Plan Review Checklist Finish Grading Phase

Water applied continuously to all disturbed portions of the site by means of water truck/water pull as necessary to maintain sufficient visible moisture on the soil surface. For reference, one 2,000 gallon water truck can treat approximately 4 acres of active construction per hour. Also, for cut and fill activities, one 10,000 gallon water pull is estimated to be necessary for each 7,000 cubic yards of daily earth-movement. Multiple 4,000-gallon water trucks may be used in place of a 10,000-gallon water pull. Touch and visual contrast are reasonably good indicators of soil moisture. Surface areas that are dry to the touch and appear lighter-colored require the application of additional water to prevent visible or fugitive dust. Require the Applicant to specify the number of watering vehicles available for dust control during finish grading and during off-hours as well as availability of back-up water trucks if the site experiences dust control problems.

Water towers are necessary for projects with more than 10 acres of active construction. Without a water tower, it can take up to 30 minutes to fill a 2,000 gallon water truck. Also, multiple water towers are necessary for projects that use water pulls as filling one 10,000 gallon water pull can drain a water tower which takes up to 40 minutes to refill.

Wind fencing is necessary between the site and nearby residences or businesses to reduce fugitive dust. Off-site upwind fencing and on-site wind fencing for larger projects can also keep blow sand from being deposited onto the site or traveling through a site.

Chemical dust suppressants are to be applied at a concentration of at least 10 to 1 to finish graded areas once final elevations have been reached. For areas that will remain inactive for longer periods, vegetation can be a cost-effective alternative to chemical stabilization. Wind fencing or other obstructions can keep the stabilized area free from future disturbances.

Construction site access(es) are to be improved with 1.5" gravel maintained to a depth of at least 4" with a minimum width of at least 20', extending 100 feet into the project site.

Equipment staging areas are to be treated with 1.5" gravel maintained to a depth of 4".

Internal roadway networks are to be treated with chemical dust suppressants at a minimum rate of at least 4 to 1 and retreated on a monthly basis once final roadway elevations have been reached.

Employee parking areas are to be treated with chemical dust suppressants at a mix ratio of at least 4 to 1 and retreated on at least a monthly basis or covered with 1.5" gravel maintained to a depth of 4" to prevent fugitive dust.

Other (specify): _____

Remember...
DUST CONTROL IS REQUIRED 24 HOURS A DAY, 7 DAYS A WEEK,
REGARDLESS OF CONSTRUCTION STATUS

**Plan Review Checklist
Construction Phase**

Water applied continuously to all disturbed portions of the site by means of water truck/water pull is necessary to maintain sufficient visible moisture on the soil surface. For reference, one 2,000 gallon water truck can treat approximately 4 acres of active construction per hour. Touch and visual contrast are reasonably good indicators of soil moisture. Surface areas that are dry to the touch and appear lighter-colored require the application of additional water to prevent visible or fugitive dust. Require the Applicant to specify the number of watering vehicles available for dust control during the construction phase and during off-hours as well as availability of back-up water trucks if the site experiences dust control problems.

Wind fencing is necessary between the site and nearby residences or businesses. Off-site upwind fencing and on-site wind fencing for larger projects can also keep blowsand from being deposited onto the site or traveling through the site. Block walls, if part of the final project, can replace wind fencing during the construction phase.

Chemical dust suppressants are to be applied at a concentration of at least 20 to 1 to finish graded areas once final elevations have been reached. For areas that will remain inactive for longer periods, vegetation can be a cost-effective alternative to chemical stabilization. Wind fencing or other obstructions can keep the stabilized area free from future disturbances.

Construction site accesses are to be improved with 1.5" gravel, maintained to a depth of 4", with a width of at least 20', extending 100' into the project site. Paving internal roadways can substitute for gravel.

Internal roadway networks are to be paved as early as feasible in the construction phase. Street sweeping of internal and/or external access roads will likely be required to control entrained road dust.

Employee parking areas are to be treated with chemical dust suppressants at a mix ratio of no less than 4 to 1 and retreated on a monthly basis, or more frequently if fugitive dust is observed. If internal roadway is complete, employees are to be instructed to park on paved roads.

Other (specify): _____

**Remember...
DUST CONTROL IS REQUIRED 24 HOURS A DAY, 7 DAYS A WEEK,
REGARDLESS OF CONSTRUCTION STATUS**

RULE 403 IMPLEMENTATION HANDBOOK

REASONABLY AVAILABLE CONTROL MEASURES

Paragraph (d)(3) of Rule 403 allows activities outside the South Coast Air Basin (see Figure 2-1) to implement reasonably available control measures in lieu of best available control measures. Additionally, as specified by subparagraph (f)(3)(D) of Rule 403, any person seeking approval of a fugitive dust emissions control plan for projects outside the South Coast Air Basin must demonstrate to the satisfaction of the District that the given activity is employing all reasonably available fugitive dust control measures.

The District has prepared the attached listing of reasonably available fugitive dust control measures for a variety of source categories. This list is based on the U.S. Environmental Protection Agency's reference document entitled, "Control of Open Fugitive Dust Sources," Midwest Research Institute, September 1988.

The District encourages the use of those dust control measures that minimize the use of potable water. When water is needed, reclaimed water should be utilized to the greatest extent feasible.

REASONABLY AVAILABLE CONTROL MEASURES

The left column contains a listing of the sources of fugitive dust which are intended for emission control under District Rule 403 and a listing of control measures and high-wind measures. The right column contains a description of the reasonably available fugitive dust control measures for each of the sources.

Source: (1) Land Clearing/Earth-Moving

CONTROL MEASURES

(A) Watering

DESCRIPTION

- (1) Application of water by means of trucks, hoses and/or sprinklers prior to conducting any land clearing. This will increase the moisture content of the soils; thereby increasing its stability.
- (2) Pre-application of water to depths of proposed cuts.
- (3) Once the land clearing/earth moving activities are complete, a second application of water can generate a thin crust that stabilizes the disturbed surface area provided that it is not disturbed. (Security fencing can be used to prevent unwanted future disturbances of sites where a surface crust has been created).

(B) Chemical stabilizers

- (1) Only effective in areas which are not subject to daily disturbances.
- (2) Vendors can supply information on product application and required concentrations to meet the specifications established by the Rule.

(C) Wind fencing

- (1) Three- to five-foot barriers with 50% or less porosity located adjacent to roadways or urban areas can be effective in reducing the amount of windblown material leaving a site.
- (2) Would likely be used in conjunction with other measures (e.g., watering, chemical stabilization, etc.) to ensure that visible emissions do not cross a property line.

(D) Cover haul vehicles

- (1) Entire surface area of hauled earth should be covered once vehicle is full.

(E) Bedliners in haul vehicles

- (1) When feasible, use in bottom-dumping haul vehicles.

HIGH WIND MEASURE

- (a) Cease all active operations; or
- (b) Apply water within 15 minutes to any soil surface which is being moved or otherwise disturbed.

Source: (2) Unpaved Roads

CONTROL MEASURES

DESCRIPTION

- | | |
|----------------------------|---|
| (F) Paving | (1) Requires street sweeping/cleaning if subject to material accumulation. |
| (G) Chemical stabilization | (1) Vendors can supply information as to application methods and concentrations to meet the specifications established by the Rule
(2) Not recommended for high volume or heavy equipment traffic use. |
| (H) Watering | (1) In sufficient quantities to keep surface moist.
(2) Required application frequency will vary according to soil type, weather conditions, and vehicular use. |
| (I) Reduce speed limits | (1) 15 mile per hour maximum. May need to be used in conjunction with watering or chemical stabilization to prevent visible emissions from crossing the property line. |
| (J) Reduce vehicular trips | (1) Access restriction or redirecting traffic to reduce vehicle trips by a minimum of 60 percent. |
| (K) Gravel | (1) Gravel maintained to a depth of four inches can be an effective measure.
(2) Should only be used in areas where paving, chemical stabilization or frequent watering is not feasible. |

HIGH WIND MEASURE

- (c) Apply a chemical stabilizer (to meet the specifications established by the Rule) prior to wind events; or
- (d) Apply water once each hour; or
- (e) Stop all vehicular traffic.

RULE 403 IMPLEMENTATION HANDBOOK

Source: (3) Storage Piles

CONTROL MEASURES

DESCRIPTION

- (L) Wind sheltering
 - (1) Enclose in silos.
 - (2) Install three-sided barriers equal to height of material, with no more than 50 percent porosity.
- (M) Watering
 - (1) Application methods include: spray bars, hoses and water trucks.
 - (2) Frequency of application will vary on site-specific conditions.
- (N) Chemical stabilizers
 - (1) Best for use on storage piles subject to infrequent disturbances.
- (O) Altering load-in/load-out procedures
 - (1) Confine load-in/load-out procedures to leeward (downwind) side of the material.
 - (2) May need to be used in conjunction with wind sheltering to prevent visible emissions from crossing the property line.
- (P) Coverings
 - (1) Tarps, plastic, or other material can be used as a temporary covering.
 - (2) When used, these should be anchored to prevent wind from removing coverings.

HIGH WIND MEASURE

- (f) Apply chemical stabilizers (to meet the specifications established by the Rule) prior to wind events; or
- (g) Apply water once per hour; or
- (h) Install temporary covers.

Source: (4) Paved Road Track-Out

CONTROL MEASURES

DESCRIPTION

- | | |
|--------------------------------|--|
| (Q) Chemical stabilization | (1) Most effective when used on areas where active operations have ceased.
(2) Vendors can supply information on methods for application and required concentrations. |
| (R) Sweep/clean roadways | (1) Either sweeping or water flushing may be used. |
| (S) Cover haul vehicles | (1) Entire surface area should be covered once vehicle is full. |
| (T) Bedliners in haul vehicles | (1) When feasible, use in bottom dumping vehicles. |
| (U) Site access improvement | (1) Pave internal roadway system.
(2) Most important segment, last 100 yards from the connection with paved public roads |

HIGH WIND MEASURE

- (i) Cover all haul vehicles; and
- (j) Clean streets with water flushing, unless prohibited by the Regional Water Quality Control Board.

RULE 403 IMPLEMENTATION HANDBOOK

Source: (5) Disturbed Surface Areas/ Inactive Construction Sites

CONTROL MEASURES

DESCRIPTION

- (Q) Chemical stabilization
 - (1) Most effective when used on areas where active operations have ceased.
 - (2) Vendors can supply information on methods for application and required concentrations.
- (R) Watering
 - (1) Requires frequent applications unless a surface crust can be developed.
- (S) Wind fencing
 - (1) Three- to five-foot barriers with 50% or less porosity adjacent to roadways or urban areas can be effective in reducing the amount of wind blown material leaving a site.
- (T) Vegetation
 - (1) Establish as quickly as possible when active operations have ceased.
 - (2) Use of drought tolerant, native vegetation is encouraged.

HIGH WIND MEASURES

- (k) Apply chemical stabilizers (to meet the specifications established by the Rule); or
- (l) Apply water to all disturbed surface areas 3 times per day.

RULE 403 IMPLEMENTATION HANDBOOK

BEST AVAILABLE CONTROL MEASURES

Rule 403, paragraph (d)(2) requires active operations [defined in Rule 403, paragraph (c)(1)] within the South Coast Air Basin (see Figure 2-1) to implement at least one best available control measure for each fugitive dust source type on site. Additionally, as specified by subparagraph (f)(3)(D) of Rule 403, any person seeking approval of a fugitive dust emissions control plan for projects within the South Coast Air Basin must demonstrate to the satisfaction of the AQMD that the given activity is employing all best available fugitive dust control measures.

The AQMD has prepared the attached listing of best available fugitive dust control measures for a variety of source categories. This list is based on the U.S. Environmental Protection Agency's reference document entitled, "Fugitive Dust Background Document and Technical Information Document for Best Available Control Measures," Office of Air and Radiation, September 1992.

The AQMD encourages the use of those dust control measures that minimize the use of potable water. When water is needed, reclaimed water should be utilized to the greatest extent feasible.

RULE 403 IMPLEMENTATION HANDBOOK

BEST AVAILABLE CONTROL MEASURES

The left column contains a listing of the sources of fugitive dust which are intended for emission control under District Rule 403 and a listing of control measures and high-wind measures. The right column contains a description of the best available fugitive dust control measures for each of the sources.

Source: (1) Land Clearing/Earth-Moving

CONTROL MEASURES

DESCRIPTION

- | | |
|--------------------------------|---|
| (A) Watering (pre-grading) | (1) Application of water by means of trucks, hoses and/or sprinklers prior to conducting any land clearing. This will increase the moisture content of the soils; thereby increasing its stability. |
| (A-1) Watering (post-grading) | (2) Pre-application of water to depths of proposed cuts. |
| (A-2) Pre-grading planning | (1) In active earth-moving areas water should be applied at sufficient frequency and quantity to prevent visible emissions from extending more than 100 feet from the point of origin. |
| (B) Chemical stabilizers | (1) Grade each phase separately, timed to coincide with construction phase; or
(2) Grade entire project, but apply chemical stabilizers or ground cover to graded areas where construction phase begins more than 60 days after grading phase ends. |
| (C) Wind fencing | (1) Only effective in areas which are not subject to daily disturbances.
(2) Vendors can supply information on product application and required concentrations to meet the specifications established by the Rule. |
| (D) Cover haul vehicles | (1) Three- to five-foot barriers with 50% or less porosity located adjacent to roadways or urban areas can be effective in reducing the amount of windblown material leaving a site. Must be implemented in conjunction with either measure (A-1) or (B). |
| (E) Bedliners in haul vehicles | (1) Entire surface area of hauled earth should be covered once vehicle is full.
(1) When feasible, use in bottom-dumping haul vehicles. |

HIGH WIND MEASURE

- (a) Cease all active operations; or
- (b) Apply water within 15 minutes to any soil surface which is being moved or otherwise disturbed.

RULE 403 IMPLEMENTATION HANDBOOK

Source: (2) Unpaved Roads

CONTROL MEASURES

DESCRIPTION

- | | |
|----------------------------|---|
| (F) Paving | (1) Requires street sweeping/cleaning if subject to material accumulation. |
| (G) Chemical stabilization | (1) Vendors can supply information as to application methods and concentrations to meet the specifications established by the Rule
(2) Not recommended for high volume or heavy equipment traffic use. |
| (H) Watering | (1) In sufficient quantities to keep surface moist.
(2) Required application frequency will vary according to soil type, weather conditions, and vehicular use. |
| (I) Reduce speed limits | (1) 15 mile per hour maximum. May need to be used in conjunction with watering or chemical stabilization to prevent visible emissions from crossing the property line. |
| (J) Reduce vehicular trips | (1) Access restriction or redirecting traffic to reduce vehicle trips by a minimum of 60 percent. |
| (K) Gravel | (1) Gravel maintained to a depth of four inches can be an effective measure.
(2) Should only be used in areas where paving, chemical stabilization or frequent watering is not feasible. |

HIGH WIND MEASURE

- (a) Apply a chemical stabilizer (to meet the specifications established by the Rule) prior to wind events; or
- (b) Apply water once each hour; or
- (c) Stop all vehicular traffic.

RULE 403 IMPLEMENTATION HANDBOOK

Source: (3) Storage Piles

CONTROL MEASURES

(L) Wind sheltering

DESCRIPTION

- (1) Enclose in silos.
- (2) Install three-sided barriers equal to height of material, with no more than 50 percent porosity.

(M) Watering

- (1) Application methods include: spray bars, hoses and water trucks.
- (2) Frequency of application will vary on site-specific conditions.

(N) Chemical stabilizers

- (1) Best for use on storage piles subject to infrequent disturbances.

(O) Altering load-in/load-out procedures

- (1) Confine load-in/load-out procedures to leeward (downwind) side of the material.
Must be used in conjunction with either measure (L), (M), (N), or (P).

(P) Coverings

- (1) Tarps, plastic, or other material can be used as a temporary covering.
- (2) When used, these should be anchored to prevent wind from removing coverings.

HIGH WIND MEASURE

- (a) Apply chemical stabilizers (to meet the specifications established by the Rule) prior to wind events; or
- (b) Apply water once per hour; or
- (c) Install temporary covers.

RULE 403 IMPLEMENTATION HANDBOOK

Source: (4) Paved Road Track-Out

CONTROL MEASURES

DESCRIPTION

Compliance with District Rule 403.

Paragraph (d)(5).

January 1999

RULE 403 IMPLEMENTATION HANDBOOK

Source: (5) Disturbed Surface Areas/ Inactive Construction Sites

CONTROL MEASURES

DESCRIPTION

- (Q) Chemical stabilization
 - (1) Most effective when used on areas where active operations have ceased.
 - (2) Vendors can supply information on methods for application and required concentrations.
- (R) Watering
 - (1) Requires frequent applications unless a surface crust can be developed.
- (S) Wind fencing
 - (1) Three- to five-foot barriers with 50% or less porosity adjacent to roadways or urban areas can be effective in reducing the amount of wind blown material leaving a site. Must be used in conjunction with either measure (Q), (R), or (T).
- (T) Vegetation
 - (1) Establish as quickly as possible when active operations have ceased.*

HIGH WIND MEASURES

- (a) Apply chemical stabilizers (to meet the specifications established by the Rule); or
- (b) Apply water to all disturbed surface areas 3 times per day.

* Use of drought tolerant, native vegetation is encouraged.

TABLE 1

BEST [REASONABLY] AVAILABLE CONTROL MEASURES FOR HIGH WIND CONDITIONS

FUGITIVE DUST SOURCE CATEGORY	<u>CONTROL MEASURES</u>
Earth-moving	(1A) Cease all active operations; OR (2A) Apply water to soil not more than 15 minutes prior to moving such soil.
Disturbed surface areas	(0B) On the last day of active operations prior to a weekend, holiday, or any other period when active operations will not occur for not more than four consecutive days: apply water with a mixture of chemical stabilizer diluted to not less than 1/20 of the concentration required to maintain a stabilized surface for a period of six months; OR (1B) Apply chemical stabilizers prior to wind event; OR (2B) Apply water to all unstabilized disturbed areas 3 times per day. If there is any evidence of wind driven fugitive dust, watering frequency is increased to a minimum of four times per day; OR (3B) Take the actions specified in Table 2, Item (3c); OR (4B) Utilize any combination of control actions (1B), (2B), and (3B) such that, in total, these actions apply to all disturbed surface areas.
Unpaved roads	(1C) Apply chemical stabilizers prior to wind event; OR (2C) Apply water twice [once] per hour during active operation; OR (3C) Stop all vehicular traffic.
Open storage piles	(1D) Apply water twice [once] per hour; OR (2D) Install temporary coverings.
Paved road track-out	(1E) Cover all haul vehicles; OR (2E) Comply with the vehicle freeboard requirements of Section 23114 of the California Vehicle Code for both public and private roads.
All Categories	(1F) Any other control measures approved by the Executive Officer and the U.S. EPA as equivalent to the methods specified in Table 1 may be used.

* Measures in [brackets] are reasonably available control measures and only apply to sources not within the South Coast Air Basin.

January 1999

TABLE 2
DUST CONTROL ACTIONS FOR EXEMPTION FROM PARAGRAPH (d)(4)*

FUGITIVE DUST SOURCE CATEGORY	CONTROL ACTIONS
Earth-moving (except construction cutting and filling areas, and mining operations)	<p>(1a) Maintain soil moisture content at a minimum of 12 percent, as determined by ASTM method D-2216, or other equivalent method approved by the Executive Officer, the California Air Resources Board, and the U.S. EPA. Two soil moisture evaluations must be conducted during the first three hours of active operations during a calendar day, and two such evaluations each subsequent four-hour period of active operations; OR</p> <p>(1a-1) For any earth-moving which is more than 100 feet from all property lines, conduct watering as necessary to prevent visible dust emissions from exceeding 100 feet in length in any direction.</p>
Earth-moving: Construction fill areas:	<p>(1b) Maintain soil moisture content at a minimum of 12 percent, as determined by ASTM method D-2216, or other equivalent method approved by the Executive Officer, the California Air Resources Board, and the U.S. EPA. For areas which have an optimum moisture content for compaction of less than 12 percent, as determined by ASTM Method 1557 or other equivalent method approved by the Executive Officer and the California Air Resources Board and the U.S. EPA, complete the compaction process as expeditiously as possible after achieving at least 70 percent of the optimum soil moisture content. Two soil moisture evaluations must be conducted during the first three hours of active operations during a calendar day, and two such evaluations during each subsequent four-hour period of active operations.</p>

* Measures in [brackets] are reasonably available control measures and only apply to sources not within the South Coast Air Basin.

TABLE 2 (Continued)

<u>FUGITIVE DUST SOURCE CATEGORY</u>	<u>CONTROL ACTIONS</u>
Earth-moving: Construction cut areas and mining operations:	(1c) Conduct watering as necessary to prevent visible emissions from extending more than 100 feet beyond the active cut or mining area unless the area is inaccessible to watering vehicles due to slope conditions or other safety factors.
Disturbed surface areas (except completed grading areas)	(2a/b) Apply dust suppression in sufficient quantity and frequency to maintain a stabilized surface. Any areas which cannot be stabilized, as evidenced by wind driven fugitive dust must have an application of water at least twice per day to at least 80 [70] percent of the unstabilized area.
Disturbed surface areas: Completed grading areas	(2c) Apply chemical stabilizers within five working days of grading completion; OR (2d) Take actions (3a) or (3c) specified for inactive disturbed surface areas.
Inactive disturbed surface areas	(3a) Apply water to at least 80 [70] percent of all inactive disturbed surface areas on a daily basis when there is evidence of wind driven fugitive dust, excluding any areas which are inaccessible to watering vehicles due to excessive slope or other safety conditions; OR (3b) Apply dust suppressants in sufficient quantity and frequency to maintain a stabilized surface; OR (3c) Establish a vegetative ground cover within 21 [30] days after active operations have ceased. Ground cover must be of sufficient density to expose less than 30 percent of unstabilized ground within 90 days of planting, and at all times thereafter; OR (3d) Utilize any combination of control actions (3a), (3b), and (3c) such that, in total, these actions apply to all inactive disturbed surface areas.

* Measures in [brackets] are reasonably available control measures and only apply to sources not within the South Coast Air Basin.

TABLE 2 (Continued)

<u>FUGITIVE DUST SOURCE CATEGORY</u>	<u>CONTROL ACTIONS</u>
Unpaved Roads	(4a) Water all roads used for any vehicular traffic at least once per every two hours of active operations [3 times per normal 8 hour work day]; OR (4b) Water all roads used for any vehicular traffic once daily and restrict vehicle speeds to 15 miles per hour; OR (4c) Apply a chemical stabilizer to all unpaved road surfaces in sufficient quantity and frequency to maintain a stabilized surface.
Open storage piles	(5a) Apply chemical stabilizers; OR (5b) Apply water to at least 80 [70] percent of the surface area of all open storage piles on a daily basis when there is evidence of wind driven fugitive dust; OR (5c) Install temporary coverings; OR (5d) Install a three-sided enclosure with walls with no more than 50 percent porosity which extend, at a minimum, to the top of the pile.
<u>All Categories</u>	(6a) Any other control measures approved by the Executive Officer and the U.S. EPA as equivalent to the methods specified in Table 2 may be used.

Measures in [brackets] are reasonably available control measures and only apply to sources not within the South Coast Air Basin.

January 1999

AQMD Recommendations

TABLE 3

TRACK-OUT CONTROL OPTIONS

PARAGRAPH (d)(5)(B)

CONTROL OPTIONS

(1)	Pave or apply chemical stabilization at sufficient concentration and frequency to maintain a stabilized surface starting from the point of intersection with the public paved surface, and extending for a centerline distance of at least 100 feet and a width of at least 20 feet.
(2)	Pave from the point of intersection with the public paved road surface, and extending for a centerline distance of at least 25 feet and a width of at least 20 feet, and install a track-out control device immediately adjacent to the paved surface such that exiting vehicles do not travel on any unpaved road surface after passing through the track-out control device.
(3)	Any other control measures approved by the Executive Officer and the U.S. EPA as equivalent to the methods specified in Table 3 may be used.

Appendix B
Reference Drawings

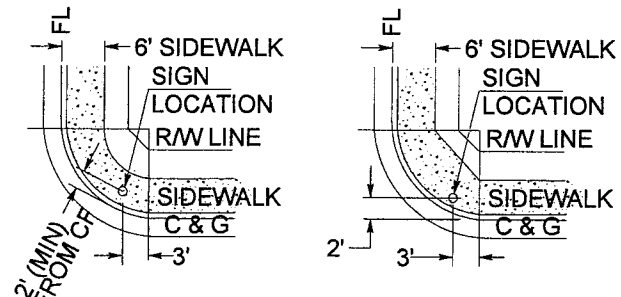
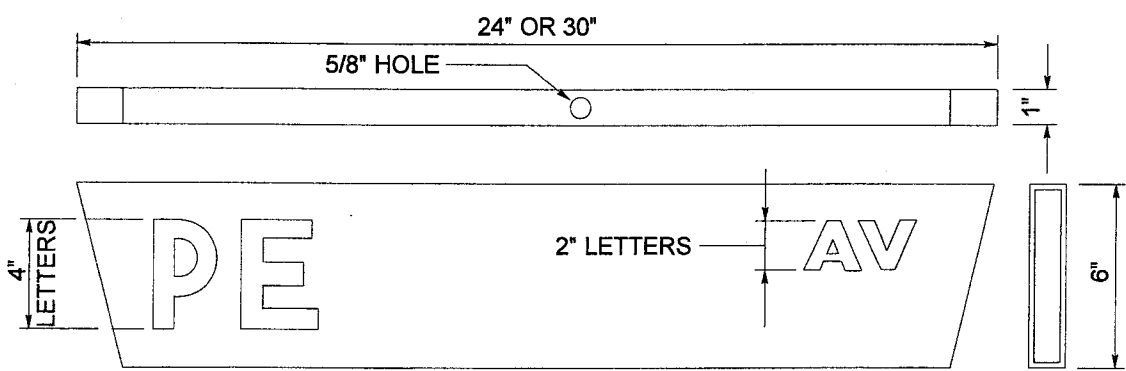
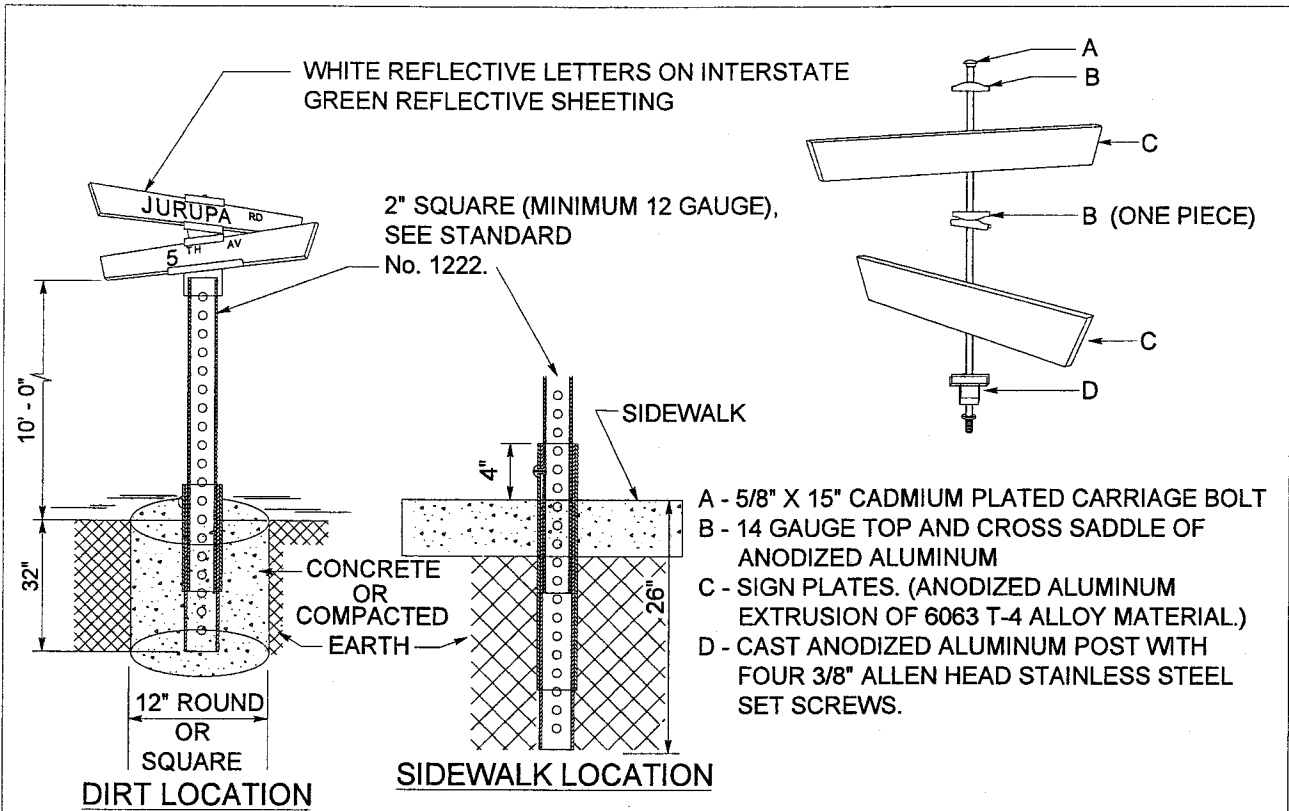

NOTE:
ONE COMPLETE NAME SIGN UNIT IS REQUIRED
AT EACH INTERSECTION WHEN PAVED WIDTHS
OR CURBED WIDTHS OF ALL INTERSECTING
STREETS ARE 40 FEET OR LESS. AT INTER-
SECTIONS WITH AN ULTIMATE PAVED WIDTH
OR CURBED WIDTH GREATER THAN 40 FEET,
USE STANDARD 1220. STD 1221 IS INTENDED
FOR RESIDENTIAL STREETS WITHIN A TRACT.
OTHER TYPES OF INTERSECTIONS, USE
STD 1220.

**INSIDE OF KNUCKLE INTERSECTION
SIGN INSTALLATION DETAILS**

APPROVED BY:				COUNTY OF RIVERSIDE																																											
DIRECTOR OF TRANSPORTATION JUAN C. PEREZ, RCE 49568				DATE																																											
<table border="1"> <thead> <tr> <th>REVISIONS</th> <th>REV.</th> <th>BY:</th> <th>APR'D</th> <th>DATE</th> <th>REV.</th> <th>BY:</th> <th>APR'D</th> <th>DATE</th> </tr> </thead> <tbody> <tr> <td></td> <td>1</td> <td>JK</td> <td>JP</td> <td>08-05-10</td> <td>4</td> <td></td> <td></td> <td></td> </tr> <tr> <td></td> <td>2</td> <td></td> <td></td> <td></td> <td>5</td> <td></td> <td></td> <td></td> </tr> <tr> <td></td> <td>3</td> <td></td> <td></td> <td></td> <td>6</td> <td></td> <td></td> <td></td> </tr> </tbody> </table>				REVISIONS	REV.	BY:	APR'D	DATE	REV.	BY:	APR'D	DATE		1	JK	JP	08-05-10	4					2				5					3				6								STREET NAME SIGN (CURB TO CURB WIDTH LESS THAN OR EQUAL TO 40')			
				REVISIONS	REV.	BY:	APR'D	DATE	REV.	BY:	APR'D	DATE																																			
					1	JK	JP	08-05-10	4																																						
	2				5																																										
	3				6																																										
				STANDARD No. 1221																																											

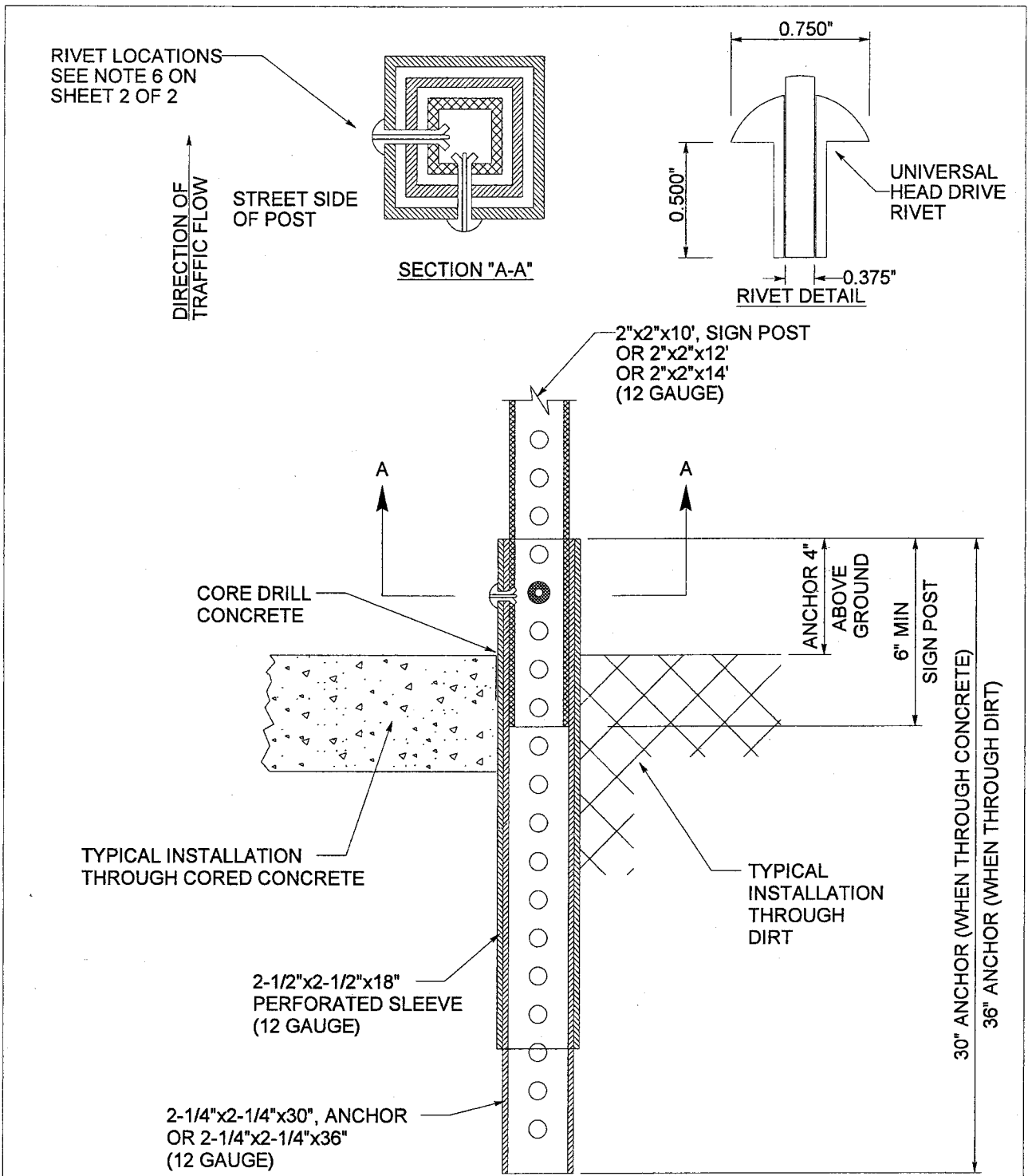

APPROVED BY:								COUNTY OF RIVERSIDE					
DIRECTOR OF TRANSPORTATION JUAN C. PEREZ, RCE 49568								DATE				SIGN POST INSTALLATION	
REVISIONS		REV.	BY:	APR'D	DATE	REV.	BY:	APR'D	DATE	STANDARD No. 1222 (1 of 2)			
		1	JK	JP	08-05-10	4							
		2				5							
		3				6							

NOTES:

1. SQUARE PERFORATED STEEL TUBE POST WITH TWO PIECE ANCHOR AND SLEEVE, "TELESPAR", SHALL BE USED FOR ALL TRAFFIC CONTROL AND INFORMATIONAL SIGNS WITHIN ROAD RIGHT-OF-WAY.
2. THE NUMBER OF POSTS REQUIRED FOR SIGN INSTALLATION SHALL BE DETERMINED BY THE AREA OF THE SIGN OR COMBINATION OF SIGNS TO BE INSTALLED. A SINGLE POST SHALL BE USED WHERE BOTH THE LENGTH AND WIDTH ARE 48" OR LESS. DOUBLE POSTS SHALL BE USED WHERE EITHER THE LENGTH OR WIDTH EXCEEDS 48".
3. THE 2 PIECE ANCHOR AND SLEEVE ASSEMBLY SHALL CONSIST OF A 2 1/4" SQUARE BY 30" (THROUGH SIDEWALK) OR 36" (THROUGH SOIL) ANCHOR WITH A 2 1/2" SQUARE BY 18" SLEEVE. ALL SLEEVES AND ANCHORS SHALL BE 12 GAUGE.
4. THE ANCHOR AND SLEEVE ASSEMBLIES SHALL BE DRIVEN SIMULTANEOUSLY UNTIL ONLY 4" REMAINS ABOVE GROUND LEVEL.
5. ALL DIRT SHALL BE REMOVED FROM THE INSIDE TOP 6" MINIMUM OF THE ANCHOR ASSEMBLY TO ALLOW FOR THE INSTALLATION OF THE SIGN POST.
6. INSTALL 2" SQUARE SIGN POST MINIMUM 6" INTO THE ANCHOR ASSEMBLY AND SECURE IN PLACE WITH TWO 3/8" DRIVE RIVETS AS SHOWN. THE RIVETS SHALL BE INSTALLED ON THE SIDE FACING TRAFFIC FLOW AND THE SIDE OF APPROACHING TRAFFIC AS SHOWN IN ORDER TO ACHIEVE THE MAXIMUM BREAK-AWAY EFFECT.
7. INSTALLATION ACCORDING TO THESE REQUIREMENTS IS ESSENTIAL TO MAINTAIN BREAK-AWAY CHARACTERISTICS OF THE POST SYSTEM.
8. SEE STANDARD No's. 815 AND 816 FOR PLACEMENT OF SIGN POST.
9. ALL ANCHOR ASSEMBLIES SHALL BE CORE DRILLED THROUGH CONCRETE AND ASPHALT.
10. ALL SIGNS ATTACHED TO PERFORATED POSTS SHALL HAVE ZINC COATED OR S.S. WASHERS BEHIND THE RIVET THAT ARE LARGER THAN THE HEAD OF THE RIVET.
11. ALL REGULATORY, WARNING AND GUIDE SIGNS INSTALLED SHALL BE 0.080 INCHES IN THICKNESS.
12. ALL SIGNS 36" OR LARGER SHALL BE INSTALLED WITH BACK BRACES SPECIFICALLY DESIGNED FOR 2" SQUARE PERFORATED POSTS. (2" RISE)
13. IN SOME INSTANCES CONCRETE FOUNDATION MAY BE REQUIRED TO ENSURE PROPER STABILITY, THIS OPTION IS TO BE USED AT THE DISCRETION OF THE ENGINEER OR ONSITE INSPECTOR.

APPROVED BY:										COUNTY OF RIVERSIDE				
_____ DIRECTOR OF TRANSPORTATION JUAN C. PEREZ, RCE 49568					DATE					SIGN POST INSTALLATION NOTES				
REVISIONS		REV.	BY:	APR'D	DATE	REV.	BY:	APR'D	DATE	STANDARD No. 1222 (2 of 2)				
		1	JK	JP	08-05-10	4								
		2				5								
		3				6								



OFFICE OF
CLERK OF THE BOARD OF SUPERVISORS
1st FLOOR, COUNTY ADMINISTRATIVE CENTER
P.O. BOX 1147, 4080 LEMON STREET
RIVERSIDE, CA 92502-1147
PHONE: (951) 955-1060
FAX: (951) 955-1071

KECIA HARPER-IHEM
Clerk of the Board of Supervisors

KIMBERLY A. RECTOR
Assistant Clerk of the Board

March 20, 2014

THE PRESS ENTERPRISE
ATTN: LEGALS
PO BOX 792
RIVERSIDE, CA 92501

FAX (951) 368-9018
E-MAIL: legals@pe.com

RE: NOTICE INVITING BIDS: BRIGGS ROAD and BARN ROAD C4-0055

To Whom It May Concern:

Attached is a copy for publication in your newspaper for **TEN (10) TIMES:**

Sunday	- March 23, 2014	Friday	- March 28, 2014
Monday	- March 24, 2014	Saturday	- March 29, 2014
Tuesday	- March 25, 2014	Sunday	- March 30, 2014
Wednesday	- March 26, 2014	Monday	- March 31, 2014
Thursday	- March 27, 2014	Tuesday	- April 1, 2014

We require your affidavit of publication immediately upon completion of the last publication.

Your invoice must be submitted to this office, WITH TWO CLIPPINGS OF THE PUBLICATION.

NOTE: PLEASE COMPOSE THIS PUBLICATION INTO A SINGLE COLUMN FORMAT.

Thank you in advance for your assistance and expertise.

Sincerely,

Cecilia Gil

Board Assistant to:
KECIA HARPER-IHEM, CLERK OF THE BOARD

Gil, Cecilia

From: mtinajero@pe.com on behalf of Master, PEC Legals <legalsmaster@pe.com>
Sent: Thursday, March 20, 2014 9:14 AM
To: Gil, Cecilia
Subject: Re: [Legals] FOR PUBLICATION: Bids for Briggs Road and Barn Road

Received for publication from March 23 through April 1. Proof with cost to follow.

Thank You!
Legal Advertising



Phone: 1-800-880-0345 / Fax: 951-368-9018 / E-mail: legals@pe.com

Please Note: Deadline is 10:30 AM two (2) business days prior to the date you would like to publish.
Additional days required for larger ad sizes

On Thu, Mar 20, 2014 at 9:03 AM, Gil, Cecilia <CCGIL@rcbos.org> wrote:

Notice Inviting Bids, for publication from March 23, 2014 to April 1, 2014. Please confirm. THANK YOU!

Cecilia Gil

Board Assistant

Clerk of the Board

951-955-8464

MS# 1010

NOTICE TO BIDDERS

County of Riverside, herein called Owner, invites sealed proposals for:

**Briggs Road and Barn Road
Traffic Signal and Lighting Project
In the Community of French Valley
Project No. C4-0055**

Bid shall be delivered to the County of Riverside Transportation Department, 14th Street Annex, 3525 14th Street, Riverside, California 92501, telephone (951) 955-6780 not later than 2:00 p.m., on Wednesday, **April 9, 2014** to be promptly opened in public at said address. Each bid shall be in accordance with plans, specifications and other contract documents, dated **February 2014**, and prepared by County of Riverside, whose address is same as the above, from whom they may be obtained upon deposit of **\$30.00** per set with 24" x 36" plans, plus mailing costs. No refund. Prospective bidders may preview the plans, specifications and other contract documents at no charge prior to purchase at the above noted location.

The Contractor is required to have a Class "A" license or "C-10" license at the time of bid submission.

Engineering Estimate	\$157,500 - \$183,500	(Base Bid)
Bid Bond	10%	
Performance Bond	100%	
Payment Bond	100%	
Working Days	35	

Website: http://www.rctlma.org/trans/con_bid_advertisements.html

Dated: March 20, 2014 Kecia Harper-Ihem, Clerk of the Board
By: Cecilia Gil, Board Assistant