

**SUBMITTAL TO THE BOARD OF SUPERVISORS
COUNTY OF RIVERSIDE, STATE OF CALIFORNIA**

835A



FROM: TLMA – Transportation Department

SUBMITTAL DATE:
March 31, 2016

SUBJECT: Approval of the Agreement between the County of Riverside and March Joint Powers Authority for the Van Buren Boulevard/Interstate 215 Interchange Lighting Infrastructure and Aesthetic Features. 1st District; [\$0]

RECOMMENDED MOTION: That the Board of Supervisors:

1. Approve the Agreement between the County of Riverside (County) and March Joint Powers Authority (JPA) for the Van Buren Boulevard/Interstate 215 (I-215) Interchange Lighting Infrastructure and Aesthetic Features; and
2. Authorize the Chairman of the Board to execute the same.

Patricia Romo
Assistant Director of Transportation

Juan C. Perez
Director of Transportation and Land Management

FINANCIAL DATA	Current Fiscal Year:	Next Fiscal Year:	Total Cost:	Ongoing Cost:	POLICY/CONSENT (Per Exec. Office)
COST	\$ 0	\$ 0	\$ 0	\$ 0	Consent <input type="checkbox"/> Policy <input checked="" type="checkbox"/>
NET COUNTY COST	\$ 0	\$ 0	\$ 0	\$ 0	

SOURCE OF FUNDS: No General Funds are used on this project
Budget Adjustment: No
For Fiscal Year: 15/16 - 16/17

C.E.O. RECOMMENDATION:

APPROVE

BY:
Tina Granda

County Executive Office Signature

MINUTES OF THE BOARD OF SUPERVISORS

On motion of Supervisor Jeffries, seconded by Supervisor Benoit and duly carried, IT WAS ORDERED that the above matter is approved as recommended.

Ayes: Jeffries, Washington and Benoit
Nays: None
Absent: Tavaglione and Ashley
Date: June 7, 2016
xc: Transp.

Kecia Harper-Ihem
Clerk of the Board
By:
Deputy

Prev. Agn. Ref.: 12/7/10, Item 3.39; 9/13/11, **District:** 1 **Agenda Number:**

3-41

FORM APPROVED COUNTY COUNSEL 5/17/16
BY: GREGORY P. PRAMOS DATE

Departmental Concurrence

Positions Added
 Change Order
 A-30
 4/5 Vote

SUBMITTAL TO THE BOARD OF SUPERVISORS, COUNTY OF RIVERSIDE, STATE OF CALIFORNIA
FORM 11: Approval of the Agreement between the County of Riverside and March Joint Powers Authority for the Van Buren Boulevard/Interstate 215 Interchange Lighting Infrastructure and Aesthetic Features. 1st District; [\$0]
DATE: March 31, 2016
PAGE: 2 of 2

BACKGROUND:

Summary

The recently completed Interstate 215 (I-215)/Van Buren Boulevard Interchange Project, provided for new wider freeway and railroad over crossings, new ramps, additional auxiliary lanes on I-215, landscaping and decorative hardscape features.

Within Caltrans right-of-way, decorative hardscape features within the I-215/Van Buren Boulevard interchange including concrete airplanes, vapor trails, rock mulch, decorative bridge lighting, and airplane silhouettes on the bridge fencing were installed as part of the project. These features are non-standard and Caltrans requires that they are maintained by the County, or its designee.

March JPA has agreed to maintain these features on behalf of the County. The Van Buren Boulevard/I-215 Lighting Infrastructure and Aesthetic Features Agreement between the County and March JPA outlines the terms and conditions for maintenance of the specific features that are shown in Exhibits A, B and C, of the agreement.

The County is required to enter into a maintenance agreement with Caltrans for the on-going maintenance of the lighting and aesthetic features. The March JPA will assume maintenance responsibility and act as designee of the County for maintenance of the non-standard interchange features. The Project Specific Maintenance Agreement between the County and Caltrans appears on this agenda as a separate item for Board approval. March JPA Commission approved the Van Buren Boulevard/I-215 Lighting Infrastructure and Aesthetic Features Agreement on February 18, 2015 and has agreed to the terms and conditions outlined in the Caltrans Project Specific Maintenance Agreement.

Impact on Residents and Businesses

The aesthetic elements enhance the appearance of the I-215/Van Buren Boulevard Interchange by paying tribute to the history of the area's military influence.

SUPPLEMENTAL:

Additional Fiscal Information

Maintenance of the aesthetic elements within the I-215/Van Buren interchange is the responsibility of the March Joint Powers Authority.

ATTACHMENTS:

Vicinity Map
Agreement

I-215 at Van Buren Boulevard Interchange Improvements

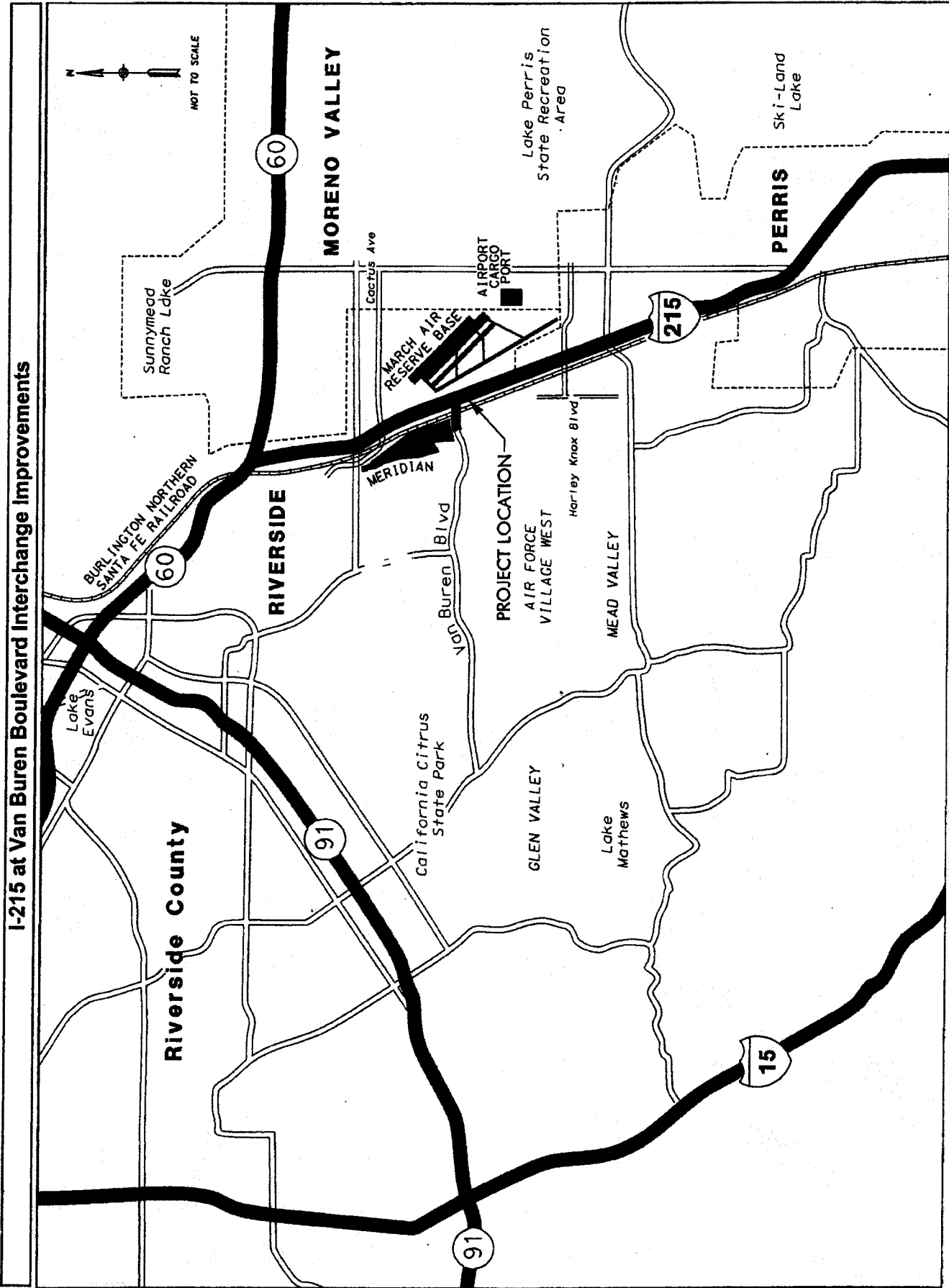

VICINITY MAP

VAN BUREN BOULEVARD/I-215 LIGHTING INFRASTRUCTURE AND AESTHSTETIC FEATURES

- 1 E. WHEREAS, AUTHORITY desired to have COUNTY install AESTHETIC FEATURES within State right-of-way,
2 and
- 3 F. WHEREAS, in accordance with the Caltrans Cooperative Agreement No. 08-1471, COUNTY and State on
4 behalf of CALTRANS will enter into a maintenance agreement for interchange improvements ("Project Specific
5 Agreement for the Interstate 215/Van Buren Boulevard Interchange in the County of Riverside" No. TR 08-4-
6 0205), and
- 7 G. WHEREAS, the COUNTY and AUTHORITY hereto mutually agree to delegate COUNTY'S maintenance
8 responsibility to AUTHORITY for the STREET LIGHTING adjacent to the March Field Air Museum and
9 AESTHETIC FEATURES within State right-of-way as identified in Exhibits "A", "B" and "C", attached hereto,
10 and
- 11 H. WHEREAS, COUNTY and AUTHORITY desire to define herein the responsibilities and obligations of each as
12 it pertains to the ownership, maintenance and energy costs of the STREET LIGHTING and AESTHETIC
13 FEATURES.

14
15 **AGREEMENT**

16 NOW THEREFORE, IT IS MUTUALLY AGREED as follows:

17
18 **STREET LIGHTING**

- 19
- 20 1. COUNTY, at PROJECT expense installed STREET LIGHTING system including service connection, adjacent to
21 the March Field Air Museum and south of the northbound loop ramp.
- 22 2. AUTHORITY will own and provide at AUTHORITY's expense, routine maintenance and emergency repair services
23 for the STREET LIGHTING system including light standards, conduits, conductors and electrical service enclosure
24 as shown in Exhibit "A". Maintenance shall commence upon execution of this Agreement.
- 25 3. AUTHORITY shall apply for service from Southern California Edison and pay for the energy costs for the STREET
26 LIGHTING.

COUNTY: 

COUNTY: JB

AUTHORITY: 

AUTHORITY: JMS

VAN BUREN BOULEVARD/I-215 LIGHTING INFRASTRUCTURE AND AESTHSTETIC FEATURES

- 1 4. AUTHORITY, or any contractor of AUTHORITY, shall apply for an Encroachment Permit from CALTRANS, which
2 will stipulate reasonable terms of entry by AUTHORITY onto State's right-of-way for the purpose of performing the
3 maintenance services on those portions of the STREET LIGHTING system within State right-of-way.
- 4 5. AUTHORITY, or any contractor of AUTHORITY, shall apply for an Encroachment Permit from COUNTY, which
5 will stipulate reasonable terms of entry by AUTHORITY onto Van Buren Boulevard right-of-way for the purpose of
6 performing the maintenance services on those portions of the STREET LIGHTING system within COUNTY right-
7 of-way.
- 8 6. COUNTY installed the STREET LIGHTING in compliance with FAA part 77 military and civilian airspace.
- 9

10 **AESTHETIC FEATURES**

11

- 12 7. COUNTY, at PROJECT expense installed AESTHETIC FEATURES including decorative hardscape features in
13 the northbound loop on-ramp and airplane silhouettes on the bridge chain link railing.
- 14 8. AUTHORITY shall, at AUTHORITY's expense, maintain decorative hardscape features including airplane
15 formations and rock mulch in the northbound loop on-ramp as shown in Exhibit "B"
- 16 9. AUTHORITY will provide at AUTHORITY's expense, routine maintenance and repair services for the airplane
17 silhouettes and connections on the bridge chain link railing as shown in Exhibit "C". Maintenance shall commence
18 upon execution of this Agreement.
- 19 10. AUTHORITY, or any contractor of AUTHORITY, shall apply for an Encroachment Permit from CALTRANS, which
20 will stipulate reasonable terms of entry by AUTHORITY onto State's right-of-way for the purpose of performing the
21 maintenance services on those portions of the AESTHETIC FEATURES within State right-of-way.
- 22 11. COUNTY and AUTHORITY acknowledge that JPA maintenance of AESTHETIC FEATURES is limited to the
23 decorative hardscape airplane formations and rock mulch in the northbound loop on-ramp, and the airplane
24 silhouettes and connections on the bridge chain link railing. This agreement does not include other overcrossing
25 aesthetic related features including the military unit insignias located under the bridge, the 5-Star features on the
26 bridge abutments, the historic Air Force insignia on the east retaining wall and bridge barrier railing, the historic
27 military rank insignia on the east retaining walls or the project landscaping which remain subject to other
28 agreements between COUNTY and State.

COUNTY: JB
COUNTY: JB

AUTHORITY: JMS
AUTHORITY: JSM

VAN BUREN BOULEVARD/I-215 LIGHTING INFRASTRUCTURE AND AESTHSTETIC FEATURES

- 1 18. No alteration or variation of the terms of this Agreement shall be valid unless made in writing and signed by both
2 Parties, and no oral understanding or agreement not incorporated herein shall be binding on either Party hereto.
- 3 19. Each provision, term, condition, covenant, and/or restriction in this Agreement shall be considered severable. In
4 the event that any provision, term, condition, covenant, and/or restriction, or part thereof, is declared invalid,
5 unconstitutional, or void for any reason, such provision or part thereof shall be severed from this Agreement and
6 shall not affect the remainder of the Agreement, which shall continue in full force and effect.
- 7 20. This Agreement may be executed in duplicate originals, each of which is deemed to be an original.
- 8 21. This Agreement shall be governed and interpreted in accordance with the laws of the State of California. The
9 venue for any disputes arising out of this Agreement shall be in the County of Riverside.
- 10 22. This Agreement shall be binding upon the successors and assigns of each Party.
- 11 23. Neither Party shall be responsible for any failure to fulfill its obligations under this Agreement due to causes beyond
12 that Party's reasonable control. This includes, but is not limited to, acts of nature, fires, floods, transportation
13 delays, labor strikes or disturbances, riots, terrorism, and war.
- 14 24. COUNTY and AUTHORITY designate the following representatives to be the primary point of contact for their
15 respective organizations regarding this Agreement.
- 16 24.1. COUNTY Representative: Patricia Romo; County of Riverside Assistant Director of Transportation
17 951-955-6740.
- 18 24.2. AUTHORITY Representative: Danielle Wheeler; March Joint Powers Authority Assistant Director; 951
19 656-7000.

20 [SIGNATURES ON FOLLOWING PAGE]

COUNTY: _____

COUNTY: _____

JB

- 5 of 7 -

AUTHORITY: _____

AUTHORITY: _____



VAN BUREN BOULEVARD/I-215 LIGHTING INFRASTRUCTURE AND AESTHSTETIC FEATURES

COUNTY OF RIVERSIDE:

By: 
Juan C. Perez
Director of Transportation and Land Management

Date: 05/12/16

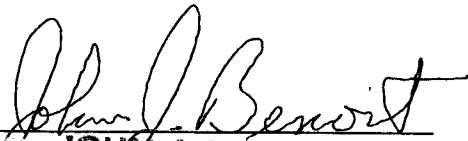
By: 
JOHN J. BENOIT
Chairman, Riverside County Board of Supervisors

Date: JUN 07 2016

Approved as to Form:
Gregory P. Priamos, County Counsel

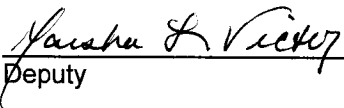
By: 
Deputy

Date: 5/17/16

Attest:

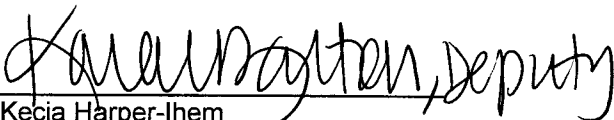
By: 
Kecia Harper-Ihem
Clerk of the Board

Date: JUN 07 2016

VAN BUREN BOULEVARD/I-215 LIGHTING INFRASTRUCTURE AND AESTHSTETIC FEATURES

MARCH JOINT POWERS AUTHORITY:

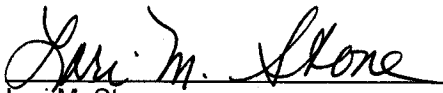
By: 
Lori M. Stone
Executive Director

Date: February 18, 2015

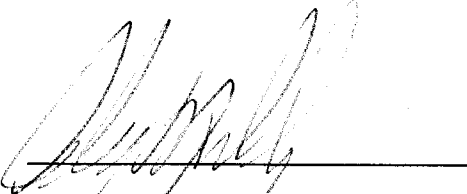
By: 
Chairman, Andy Melendrez
March Joint Powers Authority Commission

Date: 2-18-15

Approved as to Form:

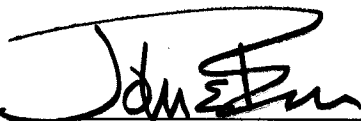
By: 
John Brown, Best, Best & Krieger LLP
Authority Counsel

Date: February 18, 2015



Attest:

By: 
Carey L. Allen, CMC
Clerk, March Joint Powers Authority Commission

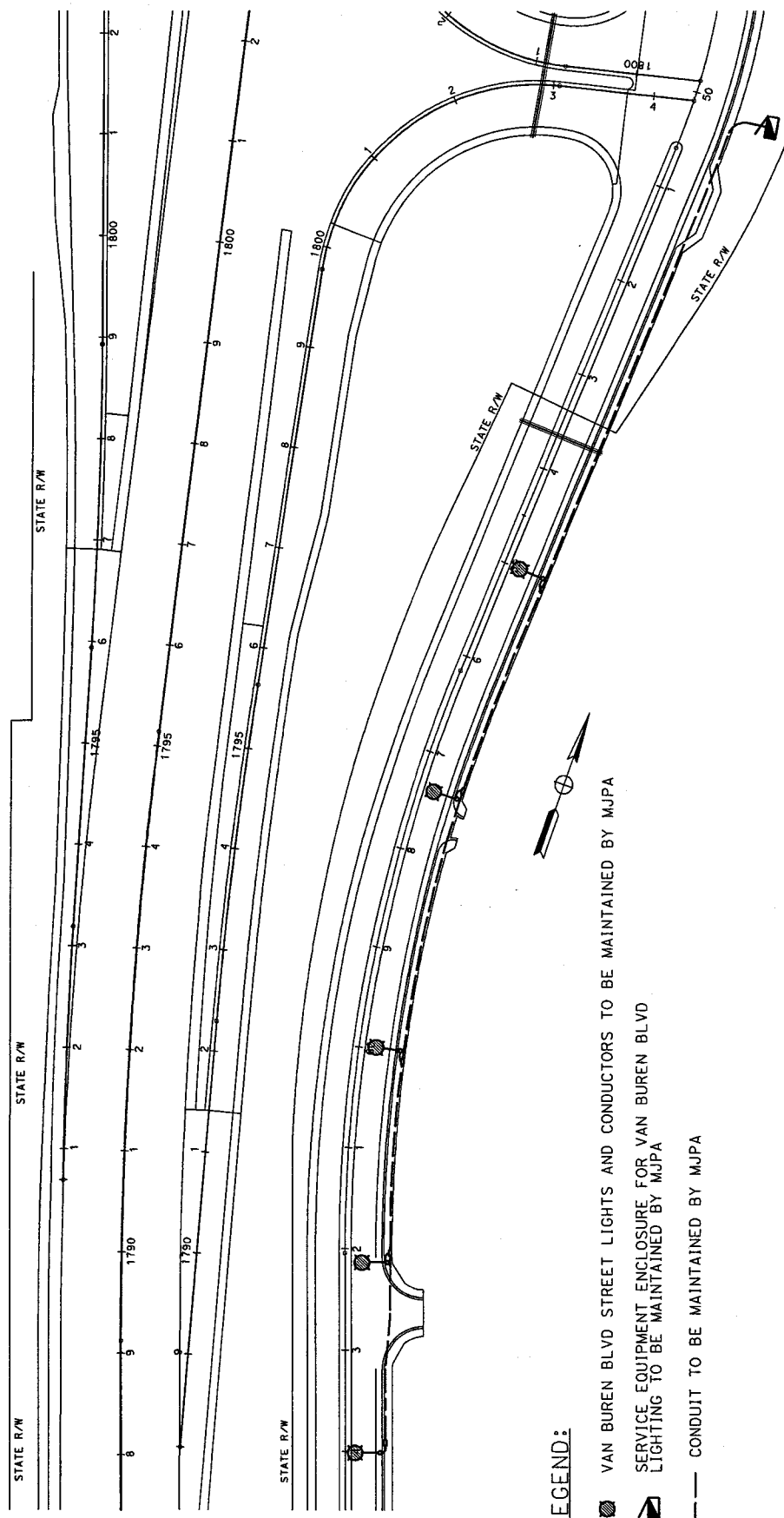
Date: 2/18/15



LEGEND:

-  VAN BUREN BLVD STREET LIGHTS AND CONDUCTORS TO BE MAINTAINED BY MJPA
-  SERVICE EQUIPMENT ENCLOSURE FOR VAN BUREN BLVD LIGHTING TO BE MAINTAINED BY MJPA
-  CONDUIT TO BE MAINTAINED BY MJPA

I-215/VAN BUREN BLVD INTERCHANGE LIGHTING AND AESTHETIC FEATURES AGREEMENT (MUSEUM) EXHIBIT "A"
NO SCALE

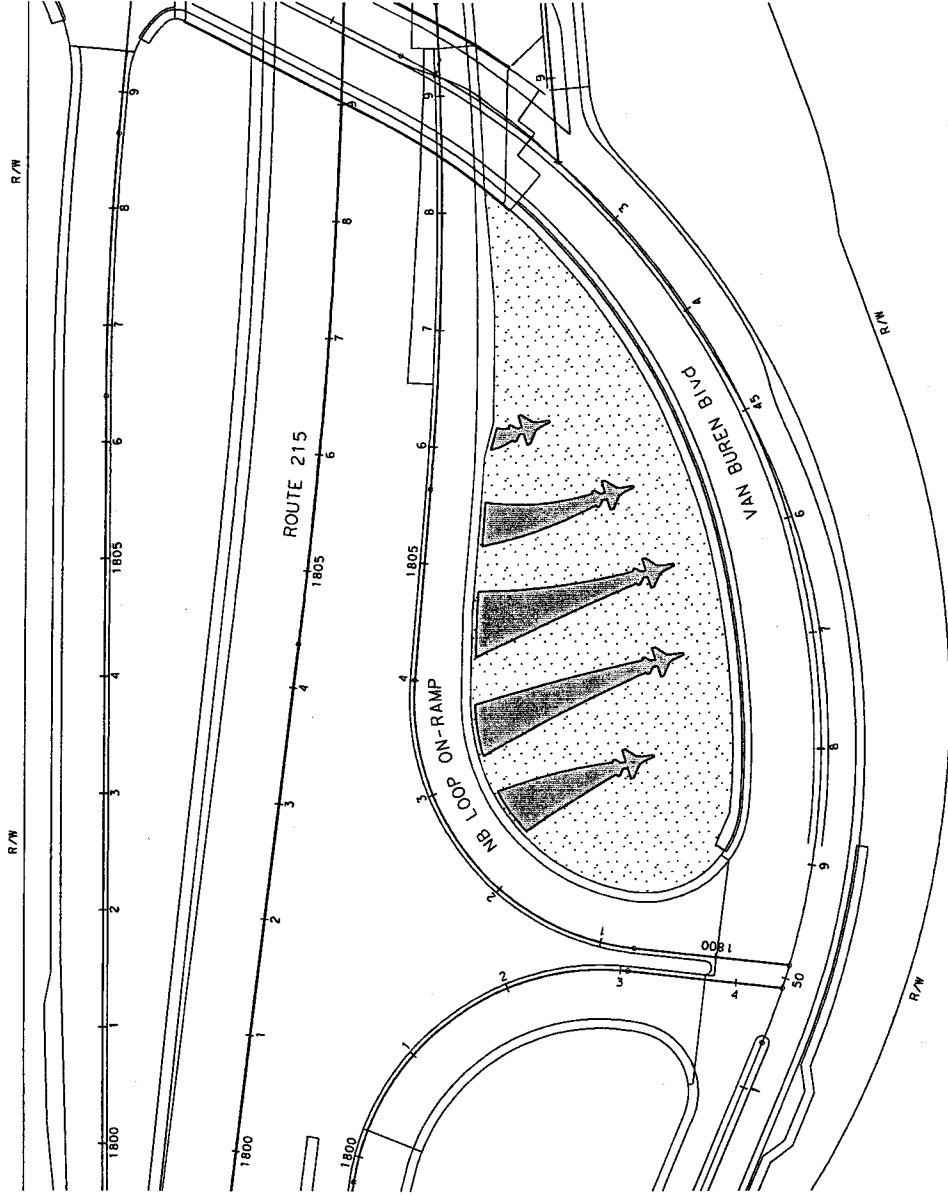

DECORATIVE HARDSCAPE
FEATURES TO BE
MAINTAINED
BY MUJA

ROCK MULCH
TO BE MAINTAINED
BY MUJA

**I-215/ VAN BUREN BLVD INTERCHANGE LIGHTING
AND AESTHETIC FEATURES AGREEMENT
AESTHETIC HARDSCAPE
EXHIBIT "B"**

NO SCALE

CL RAILING (TYPE 7)
MAINTAINED BY
STATE

PANEL 1

BRIDGE ARCHITECTURAL LIGHTING
MAINTAINED BY MJPA UNDER SEPARATE AGREEMENT

PANEL 2

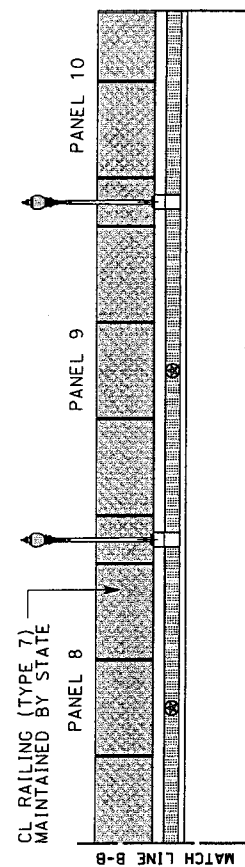
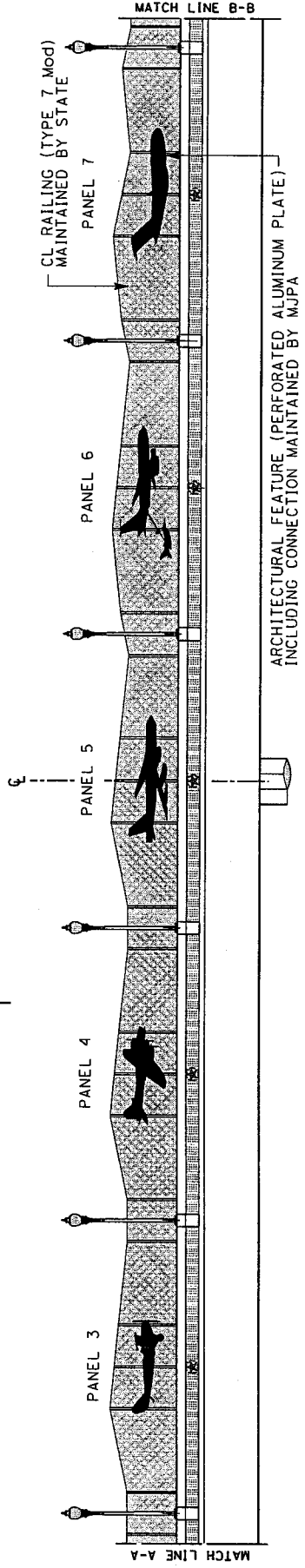
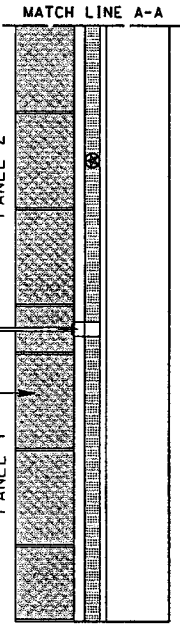

**I-215/ VAN BUREN BLVD INTERCHANGE LIGHTING
AND AESTHETIC FEATURES AGREEMENT
VAN BUREN OVERCROSSING AESTHETIC
EXHIBIT "C"**

NO SCALE

MARCH JOINT POWERS COMMISSION
OF THE
MARCH JOINT POWERS AUTHORITY

MJPA Operations - Consent Calendar
Agenda Item No. 10a(7)

Meeting Date: February 18, 2015

Action: **APPROVE AN AGREEMENT BETWEEN MARCH JOINT POWERS AUTHORITY AND RIVERSIDE COUNTY FOR MAINTENANCE OF CERTAIN VAN BUREN BOULEVARD/I-215 INTERCHANGE LIGHTING INFRASTRUCTURE AND AESTHETIC FEATURES**

Motion: Move to Approve an Agreement between March Joint Powers Authority and Riverside County for Maintenance of certain Van Buren Boulevard/I-215 Interchange Lighting Infrastructure and Aesthetic Features and authorize the Executive Director to execute the Agreement.

Background:

Through existing funding agreements, the March Joint Powers Authority (March JPA) committed to fund or obtain funding for the majority of the right-of-way, engineering and construction costs for the I-215/Van Buren Boulevard overcrossing. Engineering and construction expenses were primarily funded through the March Redevelopment Agency (\$20 million), LNR Riverside, LLC (\$7 million), CTC Proposition 1B Transportation Corridor Improvement Fund (\$10 million), RCTC Measure A Economic Development Funds (\$10 million), and TUMF (\$2.5 million).

Riverside County was responsible for construction management, and in doing so entered into a Cooperative Agreement with CalTrans (CalTrans Cooperative Agreement No. 08-1471) to construct the interchange improvements.

As components of the interchange design and construction, specific aesthetic and streetlight infrastructure was incorporated into the project to reflect the significance of the adjacent March Air Reserve Base and Riverside National Cemetery.

Given the proximity of the overcrossing to other JPA infrastructure, it was preliminarily agreed that the JPA would maintain the following items:

- Maintain street lighting infrastructure east of the I-215 overcrossing including conduit and conductors within CalTrans right-of-way and maintain five street lights within March JPA right-of-way adjacent to March Field Air Museum.
- Maintain decorative airplane formations and rock mulch within the northbound loop.

- Maintain the airplane silhouettes and mounting assemblies on the bridge chain link safety fencing.

The attached agreement between March JPA and Riverside County memorializes the responsibility for March JPA to maintain the east street lighting infrastructure and certain aesthetic features. The pedestrian scaled lighting located on the bridge was previously assigned to March JPA for maintenance through a separate agreement with the County. The scope of JPA maintenance does not include other aesthetic features of the interchange design, which includes the military unit insignias located under the bridge, the 5-Star feature on the bridge abutments, the historic Air Force insignia on the overcrossing safety barrier, the historic military rank insignia on the east retaining walls or the project landscaping, which remain maintenance responsibilities of CalTrans.

Attachments:

- 1) Agreement between the March Joint Powers Authority and Riverside County for maintenance of certain Van Buren Boulevard/I-215 Interchange Lighting Infrastructure and Aesthetic Features.

**Riverside County Board of Supervisors
Request to Speak**

Submit request to Clerk of Board (right of podium),
Speakers are entitled to three (3) minutes, subject
to Board Rules listed on the reverse side of this form.

SPEAKER'S NAME: Holmstrom

Address: _____
(only if follow-up mail response requested)

^u ^v
City: Mead Valley **Zip:** _____

Phone #: 951-230-9733

Date: June 7 - Voting Day - **Agenda #** 3-41
Day of Responsibility Taking *See Bureau I 215*

PLEASE STATE YOUR POSITION BELOW:

Position on "Regular" (non-appealed) Agenda Item:

_____ **Support** _____ **Oppose** _____ **Neutral**

Note: If you are here for an agenda item that is filed
for "Appeal", please state separately your position on
the appeal below:

_____ **Support** _____ **Oppose** _____ **Neutral**

I give my 3 minutes to: _____

BOARD RULES

Requests to Address Board on "Agenda" Items:

You may request to be heard on a published agenda item. Requests to be heard must be submitted to the Clerk of the Board before the scheduled meeting time.

Requests to Address Board on items that are "NOT" on the Agenda:

Notwithstanding any other provisions of these rules, member of the public shall have the right to address the Board during the mid-morning "Oral Communications" segment of the published agenda. Said purpose for address must pertain to issues which are under the direct jurisdiction of the Board of Supervisors. YOUR TIME WILL BE LIMITED TO THREE (3) MINUTES.

Power Point Presentations/Printed Material:

Speakers who intend to conduct a formalized Power Point presentation or provide printed material must notify the Clerk of the Board's Office by 12 noon on the Monday preceding the Tuesday Board meeting, insuring that the Clerk's Office has sufficient copies of all printed materials and at least one (1) copy of the Power Point CD. Copies of printed material given to the Clerk (by Monday noon deadline) will be provided to each Supervisor. If you have the need to use the overhead "Elmo" projector at the Board meeting, please insure your material is clear and with proper contrast, notifying the Clerk well ahead of the meeting, of your intent to use the Elmo.

Individual Speaker Limits:

Individual speakers are limited to a maximum of three (3) minutes. Please step up to the podium when the Chairman calls your name and begin speaking immediately. Pull the microphone to your mouth so that the Board, audience, and audio recording system hear you clearly. Once you start speaking, the "green" podium light will light. The "yellow" light will come on when you have one (1) minute remaining. When you have 30 seconds remaining, the "yellow" light will begin flash, indicating you must quickly wrap up your comments. Your time is up when the "red" light flashes. The Chairman adheres to a strict three (3) minutes per speaker. **Note: If you intend to give your time to a "Group/Organized Presentation", please state so clearly at the very bottom of the reverse side of this form.**

Group/Organized Presentations:

Group/organized presentations with more than one (1) speaker will be limited to nine (9) minutes at the Chairman's discretion. The organizer of the presentation will automatically receive the first three (3) minutes, with the remaining six (6) minutes relinquished by other speakers, as requested by them on a completed "Request to Speak" form, and clearly indicated at the front bottom of the form.

Addressing the Board & Acknowledgement by Chairman:

The Chairman will determine what order the speakers will address the Board, and will call on all speakers in pairs. The first speaker should immediately step to the podium and begin addressing the Board. The second speaker should take up a position in one of the chamber aisles in order to quickly step up to the podium after the preceding speaker. This is to afford an efficient and timely Board meeting, giving all attendees the opportunity to make their case. Speakers are prohibited from making personal attacks, and/or using coarse, crude, profane or vulgar language while speaking to the Board members, staff, the general public and/or meeting participants. Such behavior, at the discretion of the Board Chairman may result in removal from the Board Chambers by Sheriff Deputies.