

- D. Lock Seams: Make lock seam work flat and true to line; sweat full of solder except where installed to permit expansion and contraction. Lap flat lock seams, and lap seams where soldered, according to pitch but in no case less than 4". Make seams in direction of flow. Fill expansion joints with sealant. Plane surfaces shall be free of buckles. Provide reinforcement as necessary. Cleat and fasten substantially on approximately eight-inch centers. All cap flashing and gutter seams to be flat lock seams.
- E. Soldering: Thoroughly clean and tin material prior to soldering. Solder with heavy coppers of blunt design, properly tinned before use. For flat seam work they shall not weight less than ten pounds per pair, and for other work not less than size pounds per pair. Solder slowly with well-heated coppers, heating the seams thoroughly and completely filling them with solder. Finish surfaces neatly, full flowing and smooth. Wash acid flux thoroughly with a soda solution after soldering and completely remove soldering flux on exposed surfaces.
- F. Welding: Conform to the requirements of AWS "Standard Code for Arc and Gas Welding". Perform welding in a manner resulting in strong, durable, tight, flush, smooth, and clean joints. Weld sheet steel to produce full and complete fusion welds without inducing locked-in stresses in the metal or surface distortions. Welding on exposed surfaces shall be ground smooth and flush and finished to match adjacent surfaces.
- G. Caulking: Where indicated, caulk joints in sheet metal work and between sheet metal work and adjacent construction with polysulfide sealing compound. Apply in accordance with Caulking and Sealants Section.
- H. Coping: Shall be attached to top of parapets in strict conformance with the latest written specifications of the Sheet Metal Industry Fund of Los Angeles, and as indicated on the drawings.
- I. All sheet metal work shall be examined carefully the Contractor, Owner and Architect and if necessary, tested. The Contractor shall make all repairs to damaged items as a result of this testing, leaving them in a condition satisfactory to the Architect.

**\*\*\* END OF SECTION \*\*\***

**THIS PAGE IS INTENTIONALLY BLANK**

## SECTION 07 61 13

### STANDING SEAM METAL ROOF

#### **PART 1 - GENERAL**

##### 1.01 GENERAL REQUIREMENTS

Division 0, Contract requirements and Division 1, General Conditions apply to this section.

##### 1.02 SUMMARY

A. This Section includes

1. Factory formed metal roof panels: Standing-seam, hidden fastener, non-insulated
2. Finish must conform to the "Metal Construction Association Certified Premium Painted™" Standard.

##### 1.03 RELATED SECTIONS

- A. Division 6 Section "Rough Carpentry"
- B. Division 7 Section "Sheet Metal Flashing and Trim"

##### 1.04 PERFORMANCE REQUIREMENTS

- A. General: Provide metal roof panel assemblies that comply with performance requirements specified as determined by testing manufacturers' standard assemblies similar to those indicated for this Project, by a qualified testing and inspecting agency.
- B. Wind-Uplift Resistance: Capable of resisting design negative uplift pressures based upon maximum wind speeds of 115 mph (1.0W) per ASCE 7-10. Provide clips, fasteners, and clip spacing of type indicated and with capability to sustain, without failure, a load equal to 2 times the design negative uplift pressure.
- C. Wind-Uplift Resistance: Capable of producing sheet metal roofing assemblies that comply with UL 580 for Class 90 wind-uplift resistance. Other performance test shall include ASTM E1592 Static Air Pressure Test for Roof Coverings.
- D. Meets Energy Star® requirements in steep slope applications only.

##### 1.05 SUBMITTALS

- A. Product Data: Include construction details, material descriptions, dimensions of individual components and profiles, and finishes for each type of metal roof panel and accessory, including each type of underlayment product indicated:
  1. Concealed fastener, standing seam metal roof panels and accessories.
  2. Underlayment.
- B. Shop Drawings: Show layouts of sheet metal roofing, including plans, elevations, and keyed references to termination points. All fastening patterns shall be clearly designated to meet the specified wind speed requirements.
  1. Include details for forming, joining, and securing sheet metal roofing, including pattern of seams, termination points, expansion joints, roof penetrations, edge conditions, special conditions, connections to adjoining work, and accessory items.
- C. Coordination Drawings: Roof plans drawn to scale and coordinating penetrations and roof-mounted items. Show the following:
  1. Roof panels and attachments.
  2. Purlins and rafters.

3. Roof-mounted items including roof hatches, equipment supports, pipe supports and penetrations, lighting fixtures, snow guards, and items mounted on roof curbs.
- D. Samples: For each exposed finish.
- E. Field quality control inspection reports, to be submitted for warranty program level, if applicable.
- F. Product test reports. Based on evaluation of comprehensive tests performed by a qualified testing agency, for the following:
  1. Metal Roof Panels: Include reports for UL 790/ASTM E 108, UL 580, ASTM E 283, ASTM E 331, Field Tested, ASTM E 1592, UL 2218, ASTM E 84 Flame Spread Rating, Paint Performance Tests.
  2. Insulation and Vapor Retarders: Include reports for thermal resistance, fire-test-response characteristics, water-vapor transmission, and water absorption.

#### 1.06 QUALITY ASSURANCE

- A. Installer Qualifications: Installer of sheet metal roofing for a minimum of 10 years.
- B. Roll-Formed Sheet Metal Roofing Fabricator Qualifications: Minimum of 10 years factory forming experience.
- C. Testing Agency Qualifications: Qualified according to ASTM E 329 for testing indicated, as documented according to ASTM E 548.
- D. Source Limitations: Obtain each type of metal roof panels through one source from a single manufacturer.
- E. Sheet Metal Roofing Standard: Comply with SMACNA's "Architectural Sheet Metal Manual" and NRCA Waterproofing Manual and manufacturer's installation guidelines.
- F. Fire-Resistance Ratings: Where indicated, provide metal roof panels identical to those of assemblies tested for fire resistance that comply with ASTM E 108 in accordance with UL790.
- G. Pre-installation Conference: Conduct conference at project location with building owner, architect, installing contractor, general contractor and sheet metal roofing manufacturer a minimum of 10 days prior to start of work. All details shall be reviewed including; underlayments, substrates, fastening patterns, scheduling, trim and flashing components, accessories such as fasteners and sealants.
- H. Construction Inspection: Manufacturer shall conduct on site inspection and formal written report to architect and owner at the following intervals: 50 percent sheet metal roofing installation completion, and final inspection upon completion of roof system. Related to warranty - standard level.

#### 1.07 DELIVERY, STORAGE & HANDLING

- A. Do not deliver materials of this section to project site until suitable facilities for storage and protection are available.
- B. Protect materials from damage during transit and at project site. Store under cover, but sloped to provide positive drainage. Do not expose materials with strippable protective film to direct sunlight or extreme heat.
- C. Do not allow storage of other materials or allow staging of other work on installed metal panel system.
- D. Upon receipt of delivery of metal panel system, and prior to signing the delivery ticket, the installer is to examine each shipment for damage and for completion of the consignment.

#### 1.08 PROJECT CONDITIONS

- A. Weather Limitations: Proceed with installation only when existing and forecasted weather

conditions permit assembly of metal roof panels to be performed according to manufacturers' written instructions and warranty requirements.

- B. Field Measurements: Verify locations of roof framing and roof opening dimensions by field measurements before metal roof panel fabrication and indicate measurements on Shop Drawings.

#### 1.09 SCHEDULING

- A. Coordinate installation of roof curbs, equipment supports, and roof penetrations, which are specified in Division 7 Section "Roof Accessories."
- B. Coordinate metal panel roof assemblies with rain drainage work, flashing, trim, and construction of decks, purlins and rafters, parapets, walls, and other adjoining work to provide a leakproof, secure, and non-corrosive installation.

#### 1.10 WARRANTY

- A. Special Warranty on Finishes: Manufacturer's standard form in which manufacturer agrees to repair finish or replace sheet metal roofing that shows evidence of deterioration of factory-applied finishes within specified warranty period.
  - 1. Fluoropolymer Finish Warranty Period: 30 years from date of Substantial Completion.
- B. Special Installer's Warranty: Specified form in which Roofing Installer agrees to repair or replace components of custom-fabricated sheet metal roofing that fail in materials or workmanship within 5 years from date of Substantial Completion.
- C. Special Weathertight Warranty: Manufacturer's Standard warranty in which manufacturer agrees to repair or replace roof panel assemblies that fail to remain weathertight within the specified warranty period.
  - 1. Product Warranty Period: 5 years from date of Substantial Completion.

### **PART 2 - PRODUCTS**

#### 2.01 MANUFACTURERS

- A. Manufacturer's Qualifications:
  - All panels are to be factory formed and packaged per job requirements.
- B. Manufacturer shall have a minimum of ten (10) years' experience in the factory fabrication of metal wall panels.
- C. Specification is based upon the products of ATAS International, Inc. No other manufacturer shall be accepted as an alternate product without prior written approval. These substitution requests must meet specifications and must be submitted a minimum of ten (10) days prior to date of bid.
- D. Manufacturer must be certified to ISO 9001:2008 with design.

#### 2.02 CONCEALED-FASTENER, STANDING SEAM METAL ROOF PANELS

- A. General: Provide factory-formed metal roof panels designed to be field assembled by lapping and interconnecting raised side edges of adjacent panels with joint type indicated and mechanically attaching panels to supports using concealed clips in side laps. Include clips, cleats, pressure plates, and accessories required for weathertight installation. Unless more stringent requirements are indicated, comply with ASTM E 1514.
- B. Vertical-Rib, Seamed-Joint, Standing-Seam Metal Roof Panels: Formed with vertical ribs at panel edges and flat pan between ribs; designed for sequential installation by mechanically attaching panels to supports using concealed clips located under one side of panels and engaging opposite edge of adjacent panels, and mechanically seaming panels together with

approved seaming equipment.

1. Basis-of-Design Product: ATAS International, Inc.; Field-Lok™; FLR154 or a comparable product.
2. Manufacturer:
  - a. ATAS International, Inc.
3. Material: Aluminum .032
  - a. Texture: Smooth
  - b. Pan Coverage: 14-1/2"
  - c. Seam Height: 2"
  - d. KYNAR 5000® PDVF or HYLAR 5000® Finish
  - e. Sandstone (06)

#### 2.03 UNDERLAYMENT

- A. Self-Adhering, High-Temperature Sheet: 45 mil homogeneous rubberized asphalt waterproofing compound, glass fiber reinforced designed specifically for use under sheet metal roofing. Basis for design ATAS ATA-Shield as supplied by ATAS International, Inc. Thermal Stability: Resistant to 240 deg F; ASTM D 1970. Low Temperature Flexibility: Passes after testing at minus 20 deg F; ASTM D 1970.

#### 2.04 MISCELLANEOUS MATERIAL

- A. Fasteners: Self-tapping screws, self-locking rivets and bolts, and other suitable fasteners designed to withstand design loads. Manufacturer shall provide or authorize all fasteners utilized with the sheet metal roofing system.
  1. Exposed Fasteners: Heads matching color of sheet metal roofing by means of plastic caps or factory-applied coating.
  2. Fasteners for Flashing and Trim: Blind fasteners or screws spaced to resist wind uplift loads.
- B. Sealing Tape: Pressure-sensitive, 100 percent solid polyisobutylene compound sealing tape with release-paper backing. Provide permanently elastic, non-sag, non-toxic, non-staining tape.
- C. Elastomeric Joint Sealant: ASTM C 920, of base polymer, type, grade, class, and use classifications required to produce joints in sheet metal roofing that will remain weathertight.
- D. Expansion-Joint Sealant: For hooked-type expansion joints, which must be free to move, provide non-setting, non-hardening, non-migrating, heavy-bodied polyisobutylene sealant.
- E. Bituminous Coating: Cold-applied asphalt mastic, SSPC-Paint 12, compounded for 15 mil dry film thickness per coat.

#### 2.05 ACCESSORIES

- A. Sheet Metal Roofing Accessories: Provide components required for a complete sheet metal roofing assembly including trim, copings, fasciae, corner units, ridge closures, clips, flashings, sealants, gaskets, fillers, closure strips, and similar items. Match material and finish of sheet metal roofing, unless otherwise indicated. All trim and flashing components shall be supplied in a minimum of 12'-0" lengths and shall conform to manufacturer's standard part dimensions and details.
  1. 16 ga. Galv. steel clip base w/22 ga. Galv. steel stem designed to withstand negative-load requirements.
  2. Closures: Closed-cell, expanded, cellular, rubber or cross linked, polyolefin-foam or

closed-cell laminated polyethylene; minimum 1-inch thick, flexible closure strips; cut or premolded to match sheet metal roofing profile. Provide closure strips where indicated or necessary to ensure weathertight construction.

3. Sealants as recommended by manufacturer.
  4. Fasteners as recommended by manufacturer.
- B. Flashing and Trim: Formed from matching materials as sheet metal roof panel in gauges noted. Provide flashing and trim in heavier gauge materials as required to seal against weather and to provide finished appearance. Locations include, but are not limited to, eaves, rakes, corners, bases, framed openings, ridges, fasciae, and fillers. Finish flashing and trim with same finish system as adjacent sheet metal roofing.

## 2.06 EQUIPMENT

- A. Manufacturer must maintain quality control and maintenance procedures of all equipment. Verification of quality control procedures must be validated by a 3<sup>rd</sup> party entity.
1. Available Manufacturers: Subject to compliance with requirements, manufacturers offering products that may be incorporated into the Work include, but are not limited to, the following:
  2. Manufacturers: Subject to compliance with requirements, provide products by one of the following:
    - a. ATAS International, Inc.

## 2.07 FABRICATION

- A. General: Fabricate sheet metal roofing and components to comply with details shown, manufacturers installation details and recommendations in SMACNA's "Architectural Sheet Metal Manual" and NRCA Waterproofing Manual that apply to the design, dimensions (pan width and seam height), geometry, metal thickness, and other characteristics of installation indicated. Fabricate sheet metal roofing and accessories at the manufacturer's location to the greatest extent possible.
- B. General: Fabricate sheet metal roofing panels to comply with details shown and sheet metal roofing manufacturer's written instructions.
- C. Fabricate sheet metal roofing to allow for expansion in running work sufficient to prevent leakage, damage, and deterioration of the Work. Form exposed sheet metal work to fit substrates without excessive oil canning, buckling, and tool marks, true to line and levels indicated, and with exposed edges folded back to form hems.
1. Fold and cleat eaves as required by manufacturer to insure weathertightness and wind uplift resistance.
  2. Form and fabricate sheets, seams, strips, cleats, valleys, ridges, edge treatments, integral flashings, and other components of metal roofing to profiles, patterns, and drainage arrangements shown and as required for leak proof construction and wind uplift resistance.
- D. Metal Protection: Where dissimilar metals will contact each other, protect against galvanic action by painting contact surfaces with bituminous coating, by applying rubberized-asphalt underlayment to each contact surface, or by other permanent separation as recommended by manufacturers of dissimilar metals or by fabricator.
- E. Sheet Metal Accessories: Custom fabricate flashings and trim to comply with recommendations in SMACNA's "Architectural Sheet Metal Manual" that apply to design, dimensions, metal, and other characteristics of item indicated. Obtain field measurements for accurate fit before manufacturer fabrication.

## **PART 3 - EXECUTION**

### **3.01 EXAMINATION**

- A. Examine substrates, areas, and conditions, with Installer present, for compliance with requirements for installation tolerances, metal roof panel supports, and other conditions affecting performance of work.
  - 1. Examine primary and secondary roof framing to verify that rafters, purlins, angles, channels, and other structural panel support members and anchorages have been installed within alignment tolerances required by metal roof panel manufacturer.
  - 2. Examine solid roof sheathing to verify that sheathing joints are supported by framing or blocking and that installation is within flatness tolerances required by metal roof panel manufacturer.
  - 3. For the record, prepare written report for the General Contractor, endorsed by Installer, listing conditions detrimental to performance of work.
- B. Examine roughing-in for components and systems penetrating metal roof panels to verify actual locations of penetrations relative to seam locations of metal roof panels before metal roof panel installation.
- C. Proceed with installation only after unsatisfactory conditions have been corrected.

### **3.02 PREPARATION**

- A. Lay out and examine substrate before installation of sheet metal roofing. Space fasteners as required to resist design uplift, but not more than 24 inches o.c.
- B. Install flashings and other sheet metal to comply with requirements specified in Division 7 Section "Sheet Metal Flashing and Trim."

### **3.03 UNDERLAYMENT INSTALLATION**

- A. Self-Adhering Sheet Underlayment; ATA-SHIELD™: Install self-adhering sheet underlayment, wrinkle free, on roof sheathing under sheet metal roofing. Comply with temperature restrictions of underlayment manufacturer for installation; use primer rather than nails for installing underlayment at low temperatures. Apply at locations noted on Drawings in shingle fashion to shed water, with end laps of not less than 6 inches staggered 24 inches between courses. Overlap side edges not less than 3.5 inches. Extend underlayment a minimum of 1.5 inches of fascia board. Roll laps with roller. Cover underlayment within 14 days.

### **3.04 INSTALLATION, GENERAL**

- A. General: Anchor sheet metal roofing and other components of the Work securely in place, with provisions for thermal and structural movement. Install fasteners, protective coatings, separators, sealants, and other miscellaneous items as required for a complete roofing system and as recommended by fabricator for sheet metal roofing.
  - 1. Field cutting of sheet metal roofing by torch is not permitted.
  - 2. Rigidly fasten ridge end of sheet metal roofing and allow for positive panel attachment as per manufacturer's recommendations. All flashing details shall accommodate thermal movement.
  - 3. Provide metal closures at peaks, ridge, gable and hip caps.
  - 4. Flash and seal sheet metal roofing with weather closures at eaves, rakes, and at perimeter of all openings. Fasten with self-tapping screws.
  - 5. Locate roofing splices over, but not attached to, structural supports. Stagger roofing splices and end laps to avoid a four-panel lap splice condition.



6. Lap metal flashing over sheet metal roofing to allow moisture to run over and off the material.
- B. Fasteners: Use fasteners of size and length as required for compatibility with substrate.
- C. Metal Protection: Where dissimilar metals will contact each other or corrosive substrates, protect against galvanic action by painting contact surfaces with bituminous coating, by applying rubberized-asphalt underlayment to each contact surface, or by other permanent separation as recommended by fabricator of sheet metal roofing or manufacturers of dissimilar metals.
  1. Separate sheet metal roofing from bituminous coating where roofing will contact wood, ferrous metal, or cementitious construction. Interlock and overlap shingles and stagger end joints from shingles above and below according to shingle manufacturer's written instructions.
- D. Conceal fasteners and expansion provisions where possible in exposed work and locate to minimize possibility of leakage. Cover and seal fasteners and anchors as required for a tight installation.

### 3.05 ACCESSORY INSTALLATION

- A. General: Install accessories with positive anchorage to building and weathertight mounting and provide for thermal expansion. Coordinate installation with flashings and other components.
  1. Install components required for a complete sheet metal roofing assembly including trim, copings, ridge closures, seam covers, flashings, sealants, gaskets, fillers, closure strips, and similar items.
  2. Comply with performance requirements, manufacturer's written installation instructions, and SMACNA's "Architectural Sheet Metal Manual" and NRCA Waterproofing Manual. Provide concealed fasteners where possible, and set units true to line and level as indicated. Install work with laps, joints, and seams that will be permanently watertight and weather resistant.
- B. Coordinate with installation of:
  1. Cold Formed Metal Framing, as noted in Section 5
  2. Rough Carpentry, as noted in Section 6
  3. Sheet Metal Flashing and Trim, as noted in Section 7
  4. Metal Soffit Panels, as noted in Section 07 71 19
  5. Metal Gutters, as noted in Section 07 71 23
  6. Metal Downspouts, as noted in Section 07 71 19
  7. Metal Copings, as noted in Section 07 71 13
- C. Pipe Flashing: Form flashing around pipe penetration and metal roof panels. Fasten and seal to metal roof panels as recommended by manufacturer.

### 3.06 CLEANING AND PROTECTION

- A. Remove temporary protective coverings and strippable films, if any, as sheet metal roofing is installed. On completion of sheet metal roofing installation, clean finished surfaces, including removing unused fasteners, metal filings, pop rivet stems, and pieces of flashing. Maintain in a clean condition during construction.

### 3.07 FIELD QUALITY CONTROL

- A. Manufacturer's Field Service: Engage a factory-authorized service representative to inspect completed metal roof panel installation, including accessories. Report results in writing.

- B. Remove and replace applications of metal roof panels where inspections indicate that they do not comply with specified requirements.
- C. Additional inspections, at Contractor's expense, will be performed to determine compliance of replaced or additional work with specified requirements.

**\*\*\* END OF SECTION \*\*\***

## SECTION 07 72 33

### ROOF HATCHES & SAFETY RAILING

#### **PART 1 -- GENERAL**

##### 1.01 SUMMARY

Division 0, Contract Requirements and Division 1, General Conditions apply to this Section.

##### 1.02 DESCRIPTION

- A. Work included: Provide roof hatch system where shown on the Drawings, as specified herein, and as needed for a complete and proper installation.
- B. Section includes:
  - 1. Roof hatches
  - 2. Automatic smoke vents
  - 3. Hatch railing safety system

##### 1.03 QUALITY ASSURANCE

- A. Use adequate numbers of skilled workmen who are thoroughly trained and experienced in the necessary crafts and who are completely familiar with the specified requirements and the methods needed for proper performance of the work of this Section.
- B. Provide units listed by Underwriters Laboratories, Inc. and/or Factory Mutual Research Corporation (FMRC).
- C. OSHA compliant roof hatch safety railing system as required by OSHA Standard 1910.23 and 1910.27.

##### 1.04 SUBSTITUTIONS

Substitutions will be considered per the Instructions to Bidders, Section 3.3 Substitutions.

##### 1.05 SUBMITTALS

- A. In accordance with Article 3 of the General Conditions.
- B. Product Data: Manufacturer's specifications and technical data including the following.
  - 1. Detailed specification of construction and fabrication.
  - 2. Manufacturer's installation instructions.
- C. Shop Drawings: Indicate dimensions, description of materials and finishes, general construction, specific modifications, component connections, anchorage methods, hardware, and installation procedures.
- D. Quality Control Submittals:
  - 1. Statement of qualifications.
- E. Contract Closeout Submittals: Comply with Section 01 78 00.
  - 1. Operating and maintenance manuals.

##### 1.06 PRODUCT HANDLING

- A. Comply with pertinent provisions of Section 01 66 00.
- B. Package and ship in accordance to manufacturer's recommendations.

- C. Store in compliance to manufacturer's instructions.

1.07 FIELD CONDITIONS

- A. Verify drawing dimensions with actual field conditions.
- B. Inspect related work and adjacent surfaces.
- C. Determine specific locations for personnel access to roof for location of roof hatches.
- D. Determine type of stair or ladder needed for roof access - needed to determine size of hatch.
- E. For location of automatic smoke vents, refer to building codes for venting requirements.

**PART 2 -- PRODUCTS**

2.01 APPROVED MANUFACTURERS

- A. Nystrom Building Products: (800) 547-2635. Internet: www.nystrom.com
- B. Roof Hatch Safety-Railing System: David/Randall (877) 723-3766
- C. Or approved equal.

2.02 ALUMINUM ROOF HATCHES

- A. Acceptable Manufacturers: Subject to compliance with requirements of the Contract Documents, acceptable manufacturers are as follows or approved equal:
  - 1. Size: As indicated on the drawings.
  - 2. Model: Nystrom Model RHA
- B. Description:
  - 1. Cover and liner: 11-gauge (.090-inch) aluminum cover with 1-inch insulation and 18-gauge (.040-inch) aluminum cover liner.
  - 2. Curb: 11 gauge (.090-inch) aluminum curb with 1-inch rigid fiberboard insulation. Curb to be configured to match roof pitch.
  - 3. Hinges: Tamperproof hinge contained within hatch as part of spring assembly.
  - 4. Latch: Zinc plated steel slam latch with turn handle and inside/outside padlock hasps.
  - 5. Finish: Mill finish
  - 6. Springs: Greased heavy-duty compression springs in telescoping tubes.
  - 7. Hardware: Zinc plated steel hold open arm(s) with rubber handle that automatically locks the door when opened. Furnish hatches with interior padlock hasp and neoprene draft seal.
  - 8. Mounting flange: 3-1/2 inch.

2.03 GALVANIZED STEEL ROOF HATCHES

- A. Acceptable Manufacturers: Subject to compliance with requirements of the Contract Documents, acceptable manufacturers are as follows or approved equal:
  - 1. Size: As indicated on the drawings.
  - 2. Model: Nystrom Model RHG

B. Description

1. Cover and liner: 14-gauge (.075-inch) galvanized steel cover with 1-inch insulation and 22-gauge (.0299-inch) galvanized steel cover liner.
2. Curb: 14-gauge galvanized steel with 1-inch rigid fiberboard insulation at curb perimeter. Curb to be configured to match pitch of roof.
3. Hinges: Tamperproof hinge contained within hatch as part of spring assembly.
4. Latch: Zinc coated steel slam latch.
5. Finish: Factory applied powder coat.
6. Springs: Greased heavy-duty compression springs in telescoping tubes.
7. Hardware: Zinc plated steel hold open arm(s) with rubber handle that automatically locks the door when opened. Furnish hatches with interior padlock hasp and neoprene draft seal.
8. Mounting flange: 3½”.

2.04 ALUMINUM AUTOMATIC SMOKE VENTS

A. Acceptable Manufacturers: Subject to compliance with requirements of the Contract Documents, acceptable manufacturers are as follows or approved equal:

1. Size: As indicated on the drawings.
2. Nystrom Model SVA

B. Description:

1. Cover and liner: 11-gauge (.090-inch) aluminum cover with 1-inch insulation and 18-gauge (.040-inch) aluminum cover liner. Curb to be configured to match roof pitch.
2. Curb: 11 gauge (.090-inch) aluminum with 1-inch rigid insulation at curb perimeter.
3. Hinge: Tamperproof hinge contained within vent as part of spring assembly.
4. Latch: Positive hold/release mechanism designed to hold the covers closed against 20-lbs./sq. ft. uplift force. Released either manually or by either fusible melt out link or electric/thermal resettable link.
5. Finish: Mill finish.
6. Springs: Greased heavy-duty compression springs enclosed in telescopic tubes, designed to open vent covers automatically against 10-lbs./sq. ft. wind or snow load when released.
7. Hardware: Heavy-duty shock absorbers, neoprene draft seal, inside and outside manual release cables.
8. Mounting flange: 3½”.
9. U.L./F.M. Listing: The pyrolatch with fusible melt-out link is UL listed. Only eight sizes of double and quad-leaf models are UL and FM approved, excluding size 48 x 60.”

2.05 GALVANIZED STEEL AUTOMATIC SMOKE VENTS

A. Acceptable Manufacturers: Subject to compliance with requirements of the Contract Documents, acceptable manufacturers are as follows or approved equal:

1. Size: As indicated on the drawings.
  2. Nystrom Model SVG
- B. Description:
1. Cover and liner: 14-gauge (.075-inch) galvanized steel cover with 1-inch insulation and 22-gauge (.0299-inch) galvanized steel cover.
  2. Curb: 14-gauge (.075-inch) galvanized steel with 1.0-inch rigid fiberboard insulation at curb perimeter. Curb to be configured to match pitch roof.
  3. Hinge: Tamperproof hinge contained within vent as part of the spring assembly.
  4. Latch: Positive hold/release mechanism designed to hold the covers closed against 20-lbs./sq. ft. uplift force. Released either manually or by either fusible melt-out link or electric/thermal resettable link.
  5. Finish: Factory applied powder coat.
  6. Springs: Greased heavy-duty compression springs enclosed in telescoping tubes, designed to open vent covers automatically against 10 lbs./sq. ft. wind or snow load when released.
  7. Hardware: Heavy-duty shock absorbers, neoprene draft seal, inside and outside manual release cables.
  8. Mounting flange: 3 ½"
  9. U.L/F.M. Listing: The pyrolatch with fusible melt-out link is UL listed. Only eight sizes of double and quad-leaf models are UL and FM approved, excluding size 48 x 60."

## 2.06 SAFETY RAILING SYSTEM

- A. Nystrom Safety Railing System: Model: Select railing model to match specified hatch types from selection chart attached to this guide specification. For multiple hatch types indicate hatch designation and railing model.
- B. Description: Top rail, mid rail, and chain or swinging gate, with the hatch curb acting as the toe plate.
1. Test load: 200-pounds.
  2. Height: Minimum 42 inches above finished roof deck.
  3. Pipe: Galvanized, 1-1/4 inch ID, A53 Grade B seamed pipe or galvanized, 1-5/8 inch OD A500 seamed tube.
  4. Flat bar: 2 x 3/8 inch thickness A36 mild steel.
  5. Chain system: 3/16-inch proof coil ASTM specification, zinc plated with quick link on fixed end.
  6. Pipe ends and tops: Covered or plugged with weather and light resistant material.
  7. Bolts and washers: 3/8 x 2-1/2 inch grade Z, zinc plated.
  8. Sealant: As recommended by manufacturer.
  9. Factory finish: Hot dipped galvanized.
- C. Nystrom Safety Railing System selection Chart:

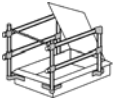
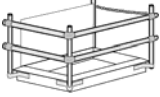
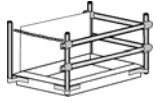
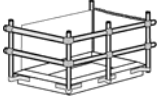
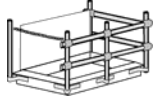
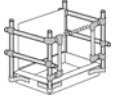
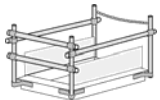
MODEL:	DESCRIPTION:	PICTURE:
RHSR-SS (size)	Nystrom Safety Railing System for standard 2'-6" x 3' roof hatches and with hatchway ladder mounted on 2'-6" side of hatch opposite of hinge lid.	
RHSR-FB-EL (size)	Nystrom Safety Railing System with forward barrier exit left for a hatch up to 2'-6" x 4'-6" where a left exit is desired, or where hatchway exit is close to the roof edge or opens up to an obstruction.	
RHSR-FB-ER (size)	Nystrom Safety Railing System with forward barrier exit right for a hatch up to 2'-6" x 4'-6" where a right exit is desired, or where hatchway exit is close to the roof edge or opens up to an obstruction.	
RHSR-FB-EEL (size)	Nystrom Safety Railing System with forward barrier end exit left (exit left with back to hinge) for roof hatches up to 4' x 8' with a ladder or stairway.	
RHSR-FB-EER (size)	Nystrom Safety Railing System with forward barrier end exit right (exit right with back to hinge) for roof hatches up to 4' x 8' with a ladder or stairway.	
RHSR-O (size)	Nystrom Safety Railing System with offset handles for where hatchway ladder or stairway is mounted opposite of hatch lid hinge and where hatch dimension on mounting side exceeds 30".	
RHSR-DL (size)	Nystrom Safety Railing System for double-leaf roof hatches.	

### PART 3 -- EXECUTION

#### 3.01 EXAMINATION

- A. Examine the areas and conditions under which work of this Section will be performed.
- B. Check openings for correct size and irregularities.
- C. Correct conditions detrimental to timely and proper completion of the Work.
- D. Do not proceed until unsatisfactory conditions are corrected.
- E. Beginning of installation means acceptance of conditions.

#### 3.02 INSTALLATION

- A. Coordinate as necessary with other trades to assure proper and adequate provision in the work of those trades for interface with the work of this Section.
- B. Comply with manufacturer's recommendations.
- C. Securely anchor roof accessories in compliance with manufacturer's instructions.
- D. Set units plumb, level, and true to line without warp or rack.
- E. Apply bituminous paint on metal surfaces of units in contact with cementitious materials and

dissimilar metals on roof units.

- F. Set railing brackets in sealant.
- G. Put operating components through at least five complete operating cycles, adjusting as required, and achieving optimum ease of operation.

3.03 FIELD QUALITY CONTROL

- A. Smoke Hatch Testing: Test for proper operation after installation by fusing the links and also test fusible link release system.
- B. Adjust and retest as required until units operate satisfactorily.
- C. Close hatches, replace links, and leave units in an operable condition.
- D. Touch up coatings as required.

**\*\*\* END OF SECTION \*\*\***



## SECTION 07 84 00

### FIRE STOPPING

#### **PART 1 -- GENERAL**

##### 1.01 SUMMARY

Division 0, Contract Requirements and Division 1, General Conditions apply to this Section.

##### 1.02 DESCRIPTION

- A. Work included: Provide firestopping where indicated on the Drawings, as specified herein, and as needed for a complete and proper installation.
- B. It is the intent of this section of the specifications to establish a single, competent source to be responsible for providing all labor, materials, products, equipment and services, to supply and install the firestopping and smoke seal work for the entire project, at the following locations, as indicated on the drawings:
  - 1. Openings in fire rated walls, floors and roofs both empty and those containing penetrations such as cables, conduits, cable trays, pipes, ducts and similar penetrating items.
  - 2. Gaps between fire-rated floor slabs and exterior curtain walls.
  - 3. Gaps between fire-rated walls and exterior curtain walls.
  - 4. Gaps located within expansion joints.
  - 5. Gaps between the tops of fire rated walls and underside of fire rated floor or roof assemblies.
  - 6. Penetrations through smoke barriers and construction enclosing compartmentalized areas involving both empty openings and openings containing penetrating items.
  - 7. Openings at each floor level in fire rated shafts or stairwells.

##### 1.03 RELATED WORK

- A. Openings through Floors and Walls:
  - 1. Fire Rated: Metal sleeves for fire rated openings through floors and walls shall be provided under applicable mechanical and electrical specification sections.
  - 2. Non-Rated: Non-rated openings through floors and walls shall be sealed under applicable mechanical and electrical specification sections.
- B. Firestopping and smoke seals within mechanical (i.e. inside ducts, dampers) and electrical assemblies shall be sealed under applicable mechanical and electrical specifications sections and only in accordance with the equipment or device manufacturers' installation instructions. Firestopping and smoke seals around outside of such mechanical and electrical assemblies, where they penetrate fire rated separations, are the responsibility of this section.

##### 1.04 REFERENCE STANDARDS/DOCUMENTS

- A. ASTM E814 - Test Method of Fire tests of Through Penetration Firestops.
- B. ANSI/UL 1479 - Fire Tests Of Through-Penetration Firestops
- C. ANSI/UL 2079 - Standard for Tests for Fire Resistance of Building Joint Systems
- D. ASTM E1966 – Standard Test Method for Fire-Resistive Joint Systems
- E. ASTM E2307 – Standard Test Method for Determining Fire Resistance of Perimeter Fire Barrier Systems Using Intermediate-Scale, Multi-Story Apparatus

- F. ASTM E119 – Standard Test Methods for Fire Tests of Building Construction and Materials
- G. ASTM C616 – Standard Specification for Mineral Fiber Block and Board Thermal Insulation
- H. UL 2079 – Standard Test Method for Fire Resistance of Building Joint Systems
- I. UL: Fire Resistance Directory, Volume 2.
- J. ITS: Directory of Listed Products.
- K. Factory Mutual, Approvals Guide

1.05 SYSTEM DESCRIPTION

- A. Firestopping Materials: Provide firestopping system(s) of sufficient thickness, width and density to provide and maintain a fire resistance rating, as indicated on drawings and in accordance with [UL], [WH], or [FM] design numbers.
- B. Provide a seal completely filling all annular spaces to prevent the passage of flame, smoke and gases through the opening in the fire separation in which it is installed.
- C. Material Compatibility: Provide materials which are compatible with all materials used in the system including materials used in or on penetrating items as well as all construction materials used in conjunction or contiguous with the system.
- D. Accessories: Provide components for each firestopping system that are needed to install fill materials. Use only components specified by the firestopping manufacturer and approved by the qualified testing and inspecting agency for the designated fire resistance rated systems. Accessories include but are not limited to the following items:
  - 1. Permanent forming/damming/backing materials
  - 2. Temporary forming materials
  - 3. Substrate primers
  - 4. Collars
  - 5. Steel sleeves

1.06 SUBSTITUTIONS

Substitutions will be considered per the Instructions to Bidders, Section 3.3 Substitutions.

1.07 SUBMITTALS

- A. In accordance with Article 3 of the General Conditions.
- B. Manufacturer's Data: Submit manufacturer's specifications, installation instructions and product data for each material required. Include [UL], [WH], or [FM] tested systems or designs to show compliance with the Contract Documents.
- C. Shop Drawings: Submit shop drawings showing typical installation details including reinforcement, anchorage, fastenings and method of installation for each type of firestopping condition.
- D. Samples: If requested, submit samples of each type of firestopping systems, smoke seals and accessories. Indicate location where material/system shall be utilized.

1.08 QUALITY ASSURANCE

- A. Manufacturer: Company specializing in manufacturing products of this Section with minimum ten (10) years documented experience, and having a quality management system that is registered as conforming to the requirements of ISO9001.
- B. Applicator: Company having a minimum of three (3) years experience in the installation of materials specified herein on projects comparable to this project. The firm shall have the written authorization of the firestopping material manufacturer(s).

1.09 REGULATORY REQUIREMENTS

- A. Conform to applicable local Building Codes for fire resistance ratings.
- B. Provide materials, accessories and application procedures which have been listed by [UL], [WH], [FM] or [tested by a nationally recognized independent testing agency] in accordance with [ASTM E814], [ANSI/UL 1479], or [ANSI/UL 2079] to achieve the required fire protection rating(s).

1.010 ENVIRONMENTAL REQUIREMENTS

- A. Do not proceed with the installation of firestopping materials when temperatures or weather conditions exceed the manufacturer's recommended limitations for installation.
- B. Ventilate solvent based and moisture-cure firestopping per firestopping manufacturer's instructions by natural means or, where this is inadequate, by forced air circulation.

1.011 DELIVERY, STORAGE AND HANDLING

Deliver materials to Site in manufacturer's sealed and labelled containers or packaging intact. Handle and store materials in accordance with manufacturer's instructions.

1.012 PROJECT/SITE CONDITIONS

Comply with manufacturer's recommended requirements for temperature, relative humidity and substrate moisture content during application and, if required, curing of materials.

1.013 SEQUENCING AND SCHEDULING

Do not install firestopping system(s) until Work within opening has been completed. Coordinate with other applicable Sections. Schedule work of other trades so that firestopping applications can be inspected prior to being covered by subsequent construction.

**PART 2 -- PRODUCTS**

2.01 ACCEPTABLE MANUFACTURERS

Provide firestopping silicone sealants, water-based sealants, intumescent sealant, mortars, mineral wool, or firestop devices from the following manufacturers:

A/D Fire Protection Systems Inc., Owens Corning Thermafiber, or Architect approved equal.

2.02 MATERIALS

- A. Provide a complete system of asbestos-free firestop systems capable of maintaining an effective barrier against flame, smoke and gases in compliance with requirements of [ASTM E814], [ANSI/UL 1479], or [ANSI/UL 2079] and listed by [UL], [WH], or [FM] and in addition are approved by jurisdictional authorities and the Consultant.
- B. A/D FIRE BARRIER Silicone Sealants: For use in: openings with penetrating items subject to high movement; multiple penetration systems; for combustible pipes up to 2-in. diameter; in control joints; in curtain wall joints; expansion joints; floor/wall joints; wall/wall joints; head of wall joints; and as a sealant for smoke barrier construction.
- C. A/D FIRE BARRIER Intumescent Caulk: For general use as a firestop sealant with: insulated pipes; pipes; electrical cables and conduit; ducts.
- D. A/D FIRE BARRIER Seal and Seal NS: Water based firestop sealants for use with: control joints; head of wall joints; floor/wall joints; wall/wall joints; multiple penetration systems; plumbing; mechanical; electrical; and where sprayed sealant application is required or desired.

- E. A/D FIRE BARRIER Mortar: For use in: large openings; static non-moving penetrations such as cable trays; for multiple penetration systems; electrical and communication bundles; conduits; non-combustible sleeves; and insulated pipes.
- F. A/D FIRE BARRIER Collars: For use in openings with single combustible pipe penetrations greater than 2-in. diameter.
- G. A/D FIRE BARRIER Pillows: For use in openings with: cable tray; multiple cable penetrations; where retrofitting of penetrating items is anticipated, and as a temporary fire stop system.
- H. Thermafiber Safing: For use in fire and smoke protection in perimeter fire containment systems between fire-rated floor slabs and exterior curtain walls, between fire-rated walls and exterior curtain walls, in floor and wall penetrations, construction joints, and other firestopping applications.
- I. Thermafiber TopStop: For use in Head-of-Wall construction between metal fluted floor/roof deck and top of fire-rated wall construction. For trapezoidal shaped flutes measuring 2" – 7" wide and depths up to 3".
- J. Fire stop system ratings: Comply with applicable Building Code requirements for locations and ratings.

### 2.03 ACCESSORIES

- A. Damming and backup materials, supports and anchoring devices: Non-combustible, to manufacturer's recommendations and in accordance with the tested system being installed as acceptable to jurisdictional authorities.
- B. Primers: As required by firestopping manufacturer and compatible with selected system and contiguous materials.
- C. Water: Potable.
- D. Firestopping for vertical (wall) applications: Non-sag caulk or spray grade sealants, Mortar, Collars or Pillows.
- E. Firestopping for horizontal (floor) applications: Non-sag caulk or self-levelling or spray grade sealants, Mortar, Collars or Pillows.
- F. Firestopping for overhead applications: Non-sag caulk or spray grade sealants or Mortar.
- G. Safing Clips: Z-shaped clips formed from galvanized steel.
- H. Tape: Pressure sensitive masking tape as recommended by the firestopping manufacturer.

## **PART 3 -- EXECUTION**

### 3.01 EXAMINATION

- A. Examine the areas and conditions under which work of this Section will be performed.
- B. Examine substrates, openings, voids, adjoining construction and conditions under which the Work is to be installed. Confirm compatibility of surfaces scheduled to receive firestopping.
- C. Correct conditions detrimental to timely and proper completion of the Work.
- D. Verify that penetrating elements are securely fixed and properly located with the proper space allowance between penetrations and surfaces of openings.
- E. Do not proceed with Work until unsatisfactory conditions are corrected.
- F. Beginning of installation means acceptance of conditions.

### 3.02 PREPARATION

- A. Surfaces to receive firestopping shall be free of dirt, dust, grease, oil, rust, loose materials, form release agents, frost, moisture or any other matter which would impair the bond of firestopping material to the substrate of penetrating item(s).
- B. For sealants and caulks, prime substrates in accordance with manufacturer's written instructions or recommendations. Confine primers to areas of bond; do not allow spillage or migration onto exposed surfaces.
- C. Do not apply firestopping and smoke seals to surfaces previously painted or treated with sealers, curing compounds, water repellent or other coatings unless tests have been performed to ensure compatibility of materials. Remove coatings as required.
- D. Ensure that anchoring devices, back-up materials, clips, sleeves, supports and other related materials used in the actual fire tests are provided.
- E. Mask where necessary to prevent firestopping materials from contacting adjoining surfaces that will remain exposed upon completion of Work. Remove tape as soon as it is possible to do so without disturbing firestopping seal with substrates.
- F. Installation is not to proceed until submittals have been completed.

### 3.03 INSTALLATION

- A. Manufacturer's Instructions: Comply with [UL], [WH] or [FM] Listings and manufacturer's instructions for the type of material and condition of opening in each case. Consult with the manufacturer's technical representative to determine proper procedure for conditions not fully covered by printed instructions. Record in writing any oral instructions received, with copy to manufacturer.
- B. Install firestopping with sufficient pressure to properly fill and seal openings to ensure an effective smoke seal. Tool or trowel exposed surfaces. Remove excess firestopping material promptly as the Work progresses and upon completion.
- C. Damming: Provide leak-proof dams as required to seal openings and contain liquid sealants, putty or mortar until cured. Install damming in accordance with manufacturer's instructions.
- D. Damming Boards: Install forming/damming materials and other accessories of type required to support fill materials during their application and in the position needed to produce the shapes and depths required to achieve fire ratings of through-penetration fire stop systems.
  - 1. Combustible Type: For temporary dams only. Remove after firestopping material has cured.
  - 2. Non-Combustible Type: For temporary or permanent dams. Provide non-combustible type wherever damming material cannot be removed after applying firestopping materials.
- E. Void Filler: Use materials recommended by the firestopping manufacturer to seal gaps created by non-combustible type damming boards and to seal around cables, conduits, pipes and where void filler material becomes part of the fire rated assembly.
- F. Sealant: Install damming material or mineral wool as required. Apply sealant so air voids are not present and sealant is in full contact with penetrating items. Tool sealant to ensure substrate contact. Remove excess sealant in accordance with manufacturer's recommendations.
- G. Mortar: Install damming material as required. Mix mortar in strict accordance with manufacturers instructions. Pump, trowel or hand pack mortar through openings to minimum thickness as recommended by manufacturer and as listed by [UL], [WH] or [FM], to achieve required fire rating.
- H. Firestopping Mineral Wool: Install firestopping by compressing material to the minimum required by [UL], [WH] or [FM] listing. Apply firestopping in sufficient thickness, depth and density so as to achieve the required fire resistance rating. Use impaling or safing clips to support and secure firestopping where required by tested system.

3.04 FIELD QUALITY CONTROL

- A. Notify Consultant when completed installations are ready for inspection prior to concealing or enclosing an area containing firestopping materials.
- B. Arrange for inspections by the Owners independent inspection and testing company, appointed and paid for by Owner.
- C. Following field inspections, provide all repair as required to ensure compliance with the Contract Documents.

3.05 CLEANING AND PROTECTION

- A. Upon completion of this work, remove all materials, equipment and debris from the site.
- B. Leave work area and adjacent surfaces in a condition acceptable to the Consultant.
- C. Leave installed work with sufficient protection to enable it to remain untouched until project turnover.

**\*\*\*END OF SECTION\*\*\***

## SECTION 07 90 00

### CAULKING & SEALANTS

#### **PART 1 -- GENERAL**

##### 1.01 GENERAL REQUIREMENTS

Division 0, Contract Requirements and Division 1, General Requirements apply to this Section.

##### 1.02 SCOPE OF WORK

Work included: Throughout the work, seal and caulk joints where shown on the Drawings and elsewhere as required to provide a positive barrier against passage of moisture and passage of air.

##### 1.03 QUALITY ASSURANCE

- A. Conform to Sealant and Waterproofers Institute requirements for materials and installation.
- B. Maintain temperature and humidity recommended by the sealant manufacturer during and after installation.
- C. Use adequate numbers of skilled workmen who are thoroughly trained and experienced in the necessary crafts and who are completely familiar with the specified requirements and the methods needed for proper performance of the work of this Section.

##### 1.04 SUBMITTALS

A. Product data: submit:

- 1. List of items that will be provided under this Section.
- 2. Manufacturer's Data: catalog cuts, dimensioned drawings, and other data needed to prove compliance with the specified requirements.
- 3. Manufacturer's recommended installation procedures which, when accepted by the Architect, will become the basis for accepting or rejecting actual installation procedures used on the Work.

##### 1.05 SUBSTITUTIONS

Substitutions will be considered per the Instructions to Bidders, Section 3.3 Substitutions.

##### 1.06 EXTENDED WARRANTY

A. Extended Warranty:

- 1. Warranties listed in this Section shall be in addition to, and not a limitation of other rights the owner may have under the contract documents.
- 2. The guarantee specified herein shall include warranties against leakage, hardening, cracking, crumbling, melting, running, shrinking or staining adjacent surfaces.
- 3. Contractor Guarantee: Contractor guarantees the work covered by this specification against all defects in material and workmanship for a period of not less than five (5) years from the date of Substantial Completion.

#### **PART 2 -- PRODUCTS**

##### 2.01 SEALANTS

A. Except as specifically otherwise accepted by the Architect, use only the types of sealants described as follows:

- 1. One component polyurethane sealant, moisture curing, low modulus, FS TT-S-

0023OC, Type II, Class A, ASTM-C-920, Class 25, for vertical and horizontal joints in connection with all building materials. Do not use in traffic areas. Minimum  $\frac{1}{4}$ " joint; maximum  $1\text{-}\frac{1}{4}$ " x  $\frac{3}{8}$ "d.

- a. Dymonic by Tremco
  - b. Sonolastic NP1 by Sonneborn
2. One-part silicone sealant, moisture curing, low modulus, FS TT-S-0023OC, Type II, Class A, FS TT-S-001543A, Class A, for vertical and horizontal joints in connection with aluminum, glass and concrete materials which require greater movement capabilities. Do not use in traffic areas. Minimum joint  $\frac{1}{4}$ " x  $\frac{3}{16}$ "d; maximum  $1$ " x  $\frac{1}{2}$ "d.
    - a. Spectrum 1 by Tremco
    - b. Omniseal by Sonneborn
    - c. Dow Corning 790
  3. One-part silicone sealant, medium modulus, neutral cure, FS S-0023OC, Type II, Class A, FS TT-S-001543A, Type II, Class A, ASTM C920, Class 25, for vertical and horizontal joints in connection with non-porous surfaces such as aluminum, glass, tile, laminated plastic and concrete. Do not use in traffic areas.
    - a. Spectrum 2 by Tremco
    - b. Omni Plus by Sonneborn
    - c. Dow Corning 795
    - d. Construction 1200 by GE
  4. Multi-Component polyurethane sealant, FS TT-S-00227E, Type I, Class A, ASTM C920 for horizontal joints in traffic areas. Minimum  $\frac{3}{8}$ " wide, depth to be  $\frac{3}{8}$ " to  $\frac{1}{2}$ " - use primer.
    - a. THC-900/901 by Tremco
    - b. Chem. Caulk 950 by Bostick
  5. One-part translucent silicone sealant, low modulus, moisture curing, FS TT-S-0023OC, Type II, Class A, FS TT-S-001543A, Type II, Class A, for vertical joints in connection with butt glazing.
    - a. 895 Silicone by Pecora
    - b. Silglaze N by GE
  6. One-part mildew resistant silicone sealant meeting requirements of FDA Regulation 21 CFR 177.2600, for vertical and horizontal joints in connection with non-porous applications as sealing around bathroom fixtures, shower-tub enclosures, sinks and urinals.
    - a. Dow Corning 786
    - b. Sanitary 1700 by GE
  7. One-part siliconized acrylic latex polymer caulk, ASTM C834-76, for interior horizontal and vertical joints in connection with window and door buck perimeters, interior wall surfaces, etc.
    - a. AC-20 by Pecora
    - b. Acrylic Latex by Tremco
  8. Roof Penetrations: Use asphalt mastic conforming to ASTM D491.



9. For other services, provide products especially formulated for the proposed use and accepted in advance by the Architect.

B. Colors:

1. The Architect will select Colors for each sealant installation to match adjacent finishes from a standard color list normally available from the specified manufacturers.
2. Should a matching standard color not be available from the accepted manufacturer except at additional charge, the Contractor shall provide such colors at no additional cost to the Owner.
3. In concealed installations, and in partially or fully exposed installations where so accepted by the Architect, use standard gray or black sealant.

2.02 PRIMERS

Use only those primers that are: non-staining, have been tested for durability on the surfaces to be sealed, and are specifically recommended for this installation by the manufacturer of the sealant used.

2.03 BACKUP MATERIALS

A. Use only those backup materials that are specifically recommended for this installation by the manufacturer of the sealant used, which are non-absorbent, and which are non-staining.

B. Acceptable types include:

1. Closed-cell resilient urethane or polyvinyl chloride foam;
2. Closed-cell polyethylene foam;
3. Closed-cell sponge of vinyl or rubber;
4. Polychloroprene tubes or beads;
5. Polyisobutylene extrusions;
6. Oil-less dry jute.

C. Preformed support strips for ceramic tile control joint and expansion joint work: Use polyisobutylene or polychloroprene rubber.

2.04 BOND-PREVENTATIVE MATERIALS

Use only one of the following as best suited for the application, and as recommended by the manufacturer of the sealant used:

1. Polyethylene tape, pressure-sensitive adhesive, with the adhesive required only to hold tape to the construction materials as indicated;
2. Aluminum foil complying with MIL-A-148E;
3. Wax paper complying with Fed. Spec. UU-P-270.

2.05 JOINT PACKING

Shall be installed in all joints to receive sealant. Material shall be a resilient type such as closed cell PVC foam or as recommended by the manufacturer. Oakum or other types of absorptive materials shall not be used as packing material.

2.06 OTHER MATERIALS

A. For masking around joints, provide masking tape complying with Fed. Spec. UU-T-106c.

B. Provide other materials, not specifically described but required for a complete and proper installation, as selected by the Contractor subject to the acceptance of the Architect.

## **PART 3 -- EXECUTION**

### **3.01 EXAMINATION**

- A. Examine the areas and conditions under which work of this Section will be performed.
- B. Verify that specified items may be installed in accordance with the approved design.
- C. Correct conditions detrimental to timely and proper completion of the Work.
- D. Do not proceed until unsatisfactory conditions are corrected.
- E. Beginning of installation means acceptance of conditions.

### **3.02 PREPARATION**

- A. Concrete and ceramic tile surfaces:
  - 1. Install only on surfaces that are dry, sound, and well brushed, wiping free from dust.
  - 2. At open joints, remove dust by mechanically blown compressed air if so required.
  - 3. Use solvent to remove oil and grease, wiping the surfaces with clean rags.
  - 4. Where surfaces have been treated, remove the surface treatment by sandblasting or wire brushing.
  - 5. Remove laitance and mortar from joint cavities.
  - 6. Where backstop is required, insert the approved backup material into the joint cavity to the depth needed.
- B. Steel surfaces:
  - 1. Steel surfaces in contact with sealant:
    - a. Sandblast as required to achieve acceptable surface for bonding.
    - b. If sandblasting is not practical, or would damage adjacent finish, scrape the metal or wire brush to remove mill scale.
    - c. Use solvent to remove oil and grease, wiping the surfaces with clean rags.
  - 2. Remove protective coatings on steel by sandblasting or by using a solvent that leaves no residue.
- C. Aluminum surfaces:
  - 1. Remove temporary protective coatings, dirt, oil, and grease.
  - 2. When masking tape is used for protective cover, remove the tape just prior to applying the sealant.
  - 3. Use only such solvents to remove protective coatings as are recommended for that purpose by the manufacturer of the aluminum work, and which are non-staining.

### **3.03 INSTALLATION OF BACKUP MATERIAL**

- A. Use only the backup material recommended by the manufacturer of the sealant used, and accepted by the Architect for the particular installation, compressing the backup material 25% to 50% to achieve a positive and secure fit.
- B. When using backup of tub or rod stock, avoid lengthwise stretching of the material. Do not twist or braid hose or rod backup stock.
- C. Interior and exterior joints where no backing has been provided or which is in excess of 3/4" deep shall be packed by this subcontractor with fiberglass or a suitable joint filler to reduce the depth to 1/2" maximum. Maximum movement: the width of the joint shall be at least four times its maximum movement.

3.04 PRIMING

- A. Use only the primer recommended by the manufacturer of the sealant, and accepted by the Architect for the particular installation, applying in strict accordance with the manufacturer's recommendations as accepted by the Architect.
- B. The priming of joints shall be by brush to reach all surfaces to which compound will be applied. Primer shall be provided on masonry, concrete and wood surfaces as recommended by sealant manufacturer. Primer shall not be applied to surfaces that will be exposed after caulking is completed.

3.05 BOND-BREAKER INSTALLATION

Provide an approved bond-breaker where recommended by the manufacturer of the sealant, and where directed by the Architect, adhering strictly to the installation recommendations as accepted by the Architect.

3.06 INSTALLATION OF SEALANTS

- A. Prior to start of installation in each joint, verify the joint type according to details on the Drawings, or as otherwise directed by the Architect, and verify that the required proportion of width of joint to depth of joint has been secured.
- B. Equipment:
  - 1. Apply sealant under pressure with power-actuated or hand gun, or by other appropriate means.
  - 2. Use guns with nozzle of proper size, and providing sufficient pressure to completely fill the joints as designed.
- C. Thoroughly and complete mask joints where the appearance of sealant on adjacent surfaces would be objectionable.
- D. Install the sealant in strict accordance with the manufacturer's recommendations as accepted by the Architect, thoroughly filling joints to the recommended depth.
- E. Tool joints to the profile shown on the Drawings, or as otherwise required if such profiles are not shown on the Drawings.
- F. Cleaning up:
  - 1. Remove masking tape immediately after joints have been tooled.
  - 2. Clean adjacent surfaces free from sealant as the installation progresses, using solvent or cleaning agent recommended by the manufacturer of the sealant used.
  - 3. The excess material shall be cleaned from the surfaces adjacent to the joint, following the caulking operation and the top of the compound deposit shall be left with a smooth even finish. No material is permitted on the exposed face of aluminum sections.

**\*\*\* END OF SECTION \*\*\***

**THIS PAGE IS INTENTIONALLY BLANK**

## SECTION 08 10 00

### METAL DOORS AND FRAMES

#### **PART 1 -- GENERAL**

##### 1.01 GENERAL REQUIREMENTS

Division 0, Contract Requirements and Division 1, General Requirements apply to this Section.

##### 1.02 SCOPE OF WORK

Work under this section comprises of furnishing hollow metal doors and frames, including transom frames, sidelight and window frames with provision for glazed, paneled or louvered openings, fire labeled and non-labeled, as scheduled.

##### 1.03 REFERENCES

###### A. Standards:

1. Current NFPA 80 – Fire Doors and Window
2. ANSI/SDI-100 – Recommended Specifications for Standard Steel Doors and Frames
3. ASTM-F 476 – Standard Test Methods for Security of Swinging Doors Assemblies
4. HMMA 862 – Guide Specifications for Commercial Security Hollow Metal Doors and Frames
5. SDI-105 – Recommended Erection Instructions for Steel Frames
6. SDI-107 – Hardware on Steel Doors (reinforcement application)
7. ANSI-A250.4 – Steel Doors and Frames Physical Endurance
8. UL10C - Standard for Positive Pressure Fire Tests of Door Assemblies
9. UL752 – Ballistic Standards

###### B. Codes:

1. Current NFPA-101 – Life Safety Code
2. 2013 CBC – California Building Code
3. ANSI-A117.1 – Accessible and Usable Building and Facilities
4. Current DOJ – ADA Standards for Accessible Design - DOJ

##### 1.04 QUALITY ASSURANCE

- A. Manufacturer shall be a member in good standing of the Steel Door Institute (SDI).
- B. Use adequate numbers of skilled workmen who are thoroughly trained and experienced in the necessary crafts and who are completely familiar with the specified requirements and the methods needed for proper performance of the work of this Section.
- C. Unless specifically otherwise accepted by the Architect, provide all products of this Section from a single manufacturer.
- D. Fire Rated Door Assemblies:
  1. All labeled fire door assemblies to be of a type that have been classified and listed in accordance with the latest edition of NFPA80 and test in compliance with NFPA-252, and UL10C. A physical label is to be affixed to the fire door at an authorized facility; embossed labels are acceptable on standard 3 sided door frames.

2. For openings required to be fire rated exceeding limitations of labeled assemblies, submit manufacturer's certification that each door and frame assembly has been constructed to conform to design, materials and construction equivalent to requirements for labeled construction.
3. Project requires door assemblies and components that are compliant with positive pressure and S-label requirements. Specifications must be cross-referenced and coordinated with hardware and other door manufacturers to ensure that total opening engineering is compatible with UL10C Standard for Positive Pressure Fire Tests of Door Assemblies.
4. Certification(s) of compliance shall be made available upon request by the Authority Having Jurisdiction.

#### 1.05 SUBMITTALS

##### A. Product data: submit:

1. List of items that will be provided under this Section.
2. Manufacturer's specifications and other data needed to prove compliance with the specified requirements.
3. Manufacturer's recommended installation procedures which, when accepted by the Architect, will become the basis for accepting or rejecting actual installation procedures used on the Work.
4. Provide a schedule of doors and frames using same reference numbers for details and door openings as those on the contract documents.
5. Submit shop drawings. Shop drawings should include the following information:
  - a. Material thickness and/or gauge.
  - b. Door core material.
  - c. Mortises and reinforcements.
  - d. Anchorage types.
  - e. Locations of exposed fasteners.
  - f. Glazed, louvered and paneled openings.
  - g. Mounting locations of standard hardware

#### 1.06 DELIVERY, STORAGE, AND HANDLING

- A. The supplier shall deliver all materials to the project site; direct factory shipments are not allowed unless agreed upon beforehand. Supplier shall coordinate delivery times and schedules with the contractor.
- B. Deliver doors cardboard wrapped or crated to provide protection during transit and jobsite storage. Provide additional protection to prevent damage to any factory-finished doors. Mark all doors and frames with opening numbers as shown on the contract documents and shop drawings.
- C. Inspect doors and frames upon delivery for damage. Minor damages may be repaired provided refinished items are equal in all respects to new work and acceptable to the architect. Otherwise, remove and replace damaged goods as directed.
- D. Store doors and frames at the building site in a dry and secure place.
  1. Place units on minimum 4" high wood blocking.
  2. Avoid use of non-vented plastic or canvas shelters that could create a humidity chamber.

3. If cardboard wrapper on door becomes wet, remove carton immediately.
4. Provide 1/4" spaces between stacked doors to promote air circulation.

1.07 EXTENDED WARRANTY

A. Extended Warranty

1. Warranties listed in this Section shall be in addition to, and not a limitation of other rights the owner may have under the contract documents.
2. All doors and frames shall be warranted in writing by the manufacturer against defects in materials and workmanship for a period of one (1) year commencing on the date of final completion and acceptance.

**PART 2 -- PRODUCTS**

2.01 MANUFACTURERS

Subject to compliance with requirements, provide standard hollow metal doors and frames by one of the following or Architect approved equal:

- A. Security Metals
- B. Door Components
- C. Ceco Corporation
- D. Curries Company
- E. Steelcraft Company

2.02 MATERIALS

- A. All doors and frames shall be manufactured of commercial quality cold rolled steel per ASTM-A366 and A568 general requirements; galvanized to A60 or G60 or galvanealed to A40 minimum coating weight standard per ASTM-A924. Internal reinforcing may be manufactured of hot rolled pickled and oiled steel per ASTM-A569
- B. Supports and anchors shall be fabricated of not less than 18-gauge sheet steel, galvanized where galvanized frames are used.
- C. Where items are to be built into exterior walls, inserts, bolts and fasteners shall be hot dipped galvanized in compliance with ASTM-A153, Class C or D as applicable.
- D. Rust inhibitive enamel or paint primer shall be used, baked on, and suitable as a base for specified finish paints complying with ANSI A224.1, "Test Procedure and Acceptance Criteria for Prime Painted Steel Surfaces on Steel Doors and Frames."
- E. Where specified supply embossed steel doors with wood grain appearance. Wood grain shall follow the pattern of a stile and rail wood door with both vertical and horizontal grain patterns. Doors with vision lites are required to have wood grain window kits.
- F. Finish: See Door & Hardware Schedule and Finish Schedules.

2.03 METAL DOORS

- A. Provide 1 3/4" thick doors of materials and ANSI/SDI-100 grades and models specified below, or as indicated on drawings or schedules:
  1. Interior Doors: Level 2, Model 2 – Seamless  
Interior doors shall be minimum 16-gauge steel with both lock and hinge rail edge of door intermittently welded, filled and ground smooth the full height of door.  
Acceptable Manufacturers/Products:

- a. Ceco: Regent-16-SEM
- b. Curries: 707N-16
- c. Steelcraft: LF16
- d. Architect Approved Equal

2. Exterior Doors: Level 3, Model 2 – Seamless

Exterior doors shall be minimum 16-gauge galvanized or galvanealed steel with both lock and hinge rail edge of door intermittently welded, filled and ground smooth the full height of door. Exterior doors shall be insulated with a solid slab of expanded polystyrene or polyurethane foam permanently bonded to the inside of each face skin. The top of all doors shall be closed flush by the addition of a 16-gauge screwed-in top cap and sealed to prevent water infiltration. The bottom channel shall include weep-holes. Acceptable Manufacturers/Products:

- a. Ceco: Legion-16-SEM
- b. Curries: 707N-16
- c. Steelcraft: LF16-Polystyrene
- d. Architect Approved Equal

3. Security Doors: Level 3, Model 2 – Seamless

Doors shall be minimum 14-gauge steel with both lock and hinge rail edge of door continuously wire welded the entire height of the door. Doors shall be reinforced, stiffened, insulated, and sound deadened with continuous 20 gauge vertical steel stiffeners spaced not more than 6" (152) apart. The stiffener ends shall be welded together at the top and bottom ends. All spaces between stiffeners shall be insulated with .75 pound density fiberglass insulation. The top of all doors shall be closed flush by the addition of a 14-gauge screwed-in top cap and sealed to prevent water infiltration. The bottom channel shall include weep-holes. Acceptable Manufacturers/Products:

- a. Ceco: Medallion-14
- b. Curries: 747T-14
- c. Steelcraft: BW14
- d. Architect Approved Equal

4. Bullet Resistant Doors

- a. Bullet resistant hollow metal doors shall be constructed with vertical steel stiffeners and fully welded vertical edge seams for enhanced strength and aesthetic appearance. Internal door construction and concealed armor plate shall vary and is dependent on the required ballistic rating. Provide ballistic level doors as follows:

- i. Level 1: Super 38 Automatic
- ii. Level 2: .357 Magnum Revolver
- iii. Level 3: .44 Magnum Revolver
- iv. Level 4: 30-06 Rifle

- b. Subject with compliance to the outline requirements, provide products by the following manufacturers:

- i. Ceco: Armorshield



- ii. Curries: 847/857
  - iii. Security Metals
  - iv. Architect Approved Equal
- B. All doors shall be reinforced for hardware as shown below where necessary to preclude the use of thru-bolts.
  - 1. Exit Devices: 14-gauge
  - 2. Door Closers: 12-gauge
- C. All doors shall be beveled 1/8" in 2" and shall have top and bottom channels of not less than 16-gauge, flush or inverted, welded to the face sheets. Doors shall have a full height 14-gauge hinge rail reinforcement channel, or individual 10 gauge hinge reinforcements
- D. All doors to conform to ANSI-A250.4 Level "A" criteria and shall be tested to 1,000,000 operating cycles and 23 twist tests. Certification of Level "A" doors is to be submitted with approval drawings by supplier upon request. Do no bid or supply any type or gauge of door not having been tested and passed these criteria

#### 2.04 METAL FRAMES

- A. Provide hollow metal frames for doors, transoms, sidelights, borrowed lights, and other openings, of types and styles as shown on the drawings and schedules. Conceal fastenings unless otherwise indicated:
  - 1. Interior Frames: Level 2, 16-gauge
  - 2. Exterior Frames: Level 2, 16-gauge, galvanized or galvanealed
  - 3. Security Grade Frames: 14-gauge
- B. Acceptable Manufacturers/Products:
  - 1. Ceco: SU Series
  - 2. Curries: M Series
  - 3. Steelcraft: F Series
- C. All frames over 36" in width shall be 14-gauge.
- D. Fabricate frames with mitered corners. Weld both the inside the throat of the corners and the face of the corners, re-prime at the welded areas. All welds to be flush with neatly mitered or butted material cuts.
- E. All frames shall have minimum 7-gauge hinge reinforcements, 14-gauge lock strike reinforcing, and 12-gauge closer reinforcing.
- F. All frames shall have minimum 7-gauge hinge reinforcements with an additional high frequency 12-gauge hinge reinforcement welded to the top hinge, 14-gauge lock strike reinforcing, and 12-gauge closer reinforcing.
- G. Provide temporary shipping bars to be removed before setting frames.
- H. Except on weather stripped frames, drill stops to receive three (3) silencers on strike jambs of single frames and two (2) silencers on heads of double frames.
- I. Provide minimum 0.0179" thick steel plaster guards or mortar boxes at back of hardware cutouts where mortar or other materials might obstruct hardware operation and to close off interior of openings

#### 2.05 DOOR LOUVERS

- A. Fire-Rated Louver:

1. Each fire-rated louver shall have the listing mark of Underwriter's Laboratories Inc. affixed to louver assembly.
2. All louvers in fire-rated doors shall be 16-gauge cold rolled steel with stainless steel operating springs.
3. Louvers shall be sight-proof per SDI-111C.

B. Fixed-Blade Louver:

1. All fixed blade louvers shall be 18-gauge cold rolled steel with mitered and welded frames and countersunk mounting holes.
2. Louvers shall be sight-proof per SDI-111C.
3. Provide insect screen where louver occur in exterior doors.

2.06 FABRICATION

- A. Fabricate steel door and frame units to be rigid, neat in appearance, and free from defects, warp, or buckle. Where practical, fit and assemble units in manufacturer's plant. Clearly identify work that cannot be permanently factory assembled before shipment, to assure proper assembly at Project site. Comply with ANSI/SDI 100 requirements.
1. Clearances shall be no more than 1/8" at jambs and heads except between non fire rated pairs of doors which may be no more than 1/4."
  2. Clearances shall be no more than 3/4" at the bottom of the doors.
  3. Clearances shall be no more than 1/4" at thresholds and curbs allow unless otherwise detailed.
- B. Fabricate exposed faces of doors and panels, including stiles and rails of non-flush units, from only cold-rolled steel sheet.
1. All doors shall be of types and sizes on the drawings, and shall be fully welded seamless construction with no visible seams or joints on their faces or vertical edges. Doors shall be strong, rigid and neat in appearance, free from warpage or buckle. Corner bends shall be true and straight and of minimum radius for the gauge of metal used.
  2. Door faces shall be joined at their vertical edges by a continuous weld extending the full height of the door. All such welds shall be ground, filled and dressed smooth to make them invisible and provide a smooth flush surface.
  3. Top and bottom edges shall be closed with a continuous recessed 16 gauge steel channel extending the full width and spot welded to both faces. Exterior doors shall have an additional flush closing channel at the top edge. Opening shall be provided in the bottom closer for escape of entrapped moisture.
  4. Doors shall be mortised, reinforced, drilled and tapped at the factory for fully template hardware only. Where surface mounted hardware is to be applied, doors shall have reinforcing plates only, with drilling and tapping to be done in the field.
  5. The Face sheets of Exterior and Security doors shall be stiffened by continuous vertical formed steel sections occupying the full thickness of the interior space between door faces. These stiffeners shall be not less than 20 gauge, spaced not more than 6" apart and securely attached to both face sheets by spot welds not more than 4" o.c. Spaces between stiffeners shall be sound deadened and insulated the full height of the door with an inorganic non-combustible batt-type material.
- C. Tolerances shall comply with SDI-117 "Manufacturing Tolerances Standard Steel Doors and Frames."

1. All door and louver frames shall be strong and rigid, neat in appearance, square, true and free of defects, warp and buckle. Molded members shall be clean cut, straight and of uniform profile and back-bends shall be as detailed.
  2. Corner joints shall have all contact edges closed tight, with trim faces and stops mitered and continuously welded. All welds shall be ground, filled and dressed smooth to make them invisible and provide a smooth flush surface.
  3. Unit frames for installation in stud partitions shall be provided with steel anchors of suitable design for welding to steel studs. Anchors shall be not less than 16-gauge and shall be securely welded inside each jamb. Anchors are to be spaced at 24" on center.
  4. Dust cover boxes of not less than 26-gauge shall be provided at all hardware mortises on frames to be set in masonry or drywall partitions.
- D. Fabricate concealed stiffeners, reinforcement, edge channels, louvers, and moldings from either cold- or hot-rolled steel sheet.
- E. Unless otherwise indicated, provide exposed fasteners with countersunk flat or oval heads for exposed screws and bolts.
- F. Labeled doors and frames shall be provided for those openings requiring fire protection ratings, as scheduled on the drawings. Such doors and frames shall be constructed as tested by the Underwriter's Laboratories, Inc., and shall bear their label for the required rating. Provide additional frame accessories as required to maintain the fire protection ratings once the frames are installed in the openings.
- G. At exterior locations and elsewhere as shown or scheduled, assemblies fabricated as thermal-insulating door and frame assemblies and tested according to ASTM C 236 or ASTM C 976 on fully operable door assemblies. Unless otherwise indicated, provide thermal-rated assemblies with a minimum U-value rating of 0.41 Btu/sq. ft. x h x deg F.
- H. Where shown or scheduled, provide door and frame assemblies fabricated as sound-reducing type, tested according to ASTM E 1408, and classified according to ASTM E 413. Unless otherwise indicated, provide acoustical assemblies with STC sound ratings of 33 or better.
- I. Prepare doors and frames to receive mortised and concealed hardware according to final door hardware schedule and templates provided by hardware supplier. Comply with applicable requirements of SDI-107 and ANSI-A115 Series specifications for door and frame preparation for hardware.
- J. Reinforce doors and frames to receive surface-applied hardware. Drilling and tapping for surface-applied hardware may be done at Project site. Provide internal reinforcements for all doors to receive door closers and exit devices.
- K. Locate hardware as indicated on Shop Drawings or, if not indicated, according to the Door and Hardware Institute's (DHI) "Recommended Locations for Architectural Hardware for Standard Steel Doors and Frames."
- L. Provide glazing stops with minimum 0.0359-inch- thick steel or 0.040-inch- thick aluminum.
- M. Provide non-removable stops on outside of exterior doors and on secure side of interior doors for glass, louvers, and other panels in doors.
- N. Provide screw-applied, removable, glazing beads on inside of glass and other panels in doors.

## **PART 3 -- EXECUTION**

### **3.01 EXAMINATION**

- A. Examine the areas and conditions under which work of this Section will be performed.
- B. Verify that specified items may be installed in accordance with the approved design.
- C. Correct conditions detrimental to timely and proper completion of the Work.
- D. Do not proceed until unsatisfactory conditions are corrected.
- E. Beginning of installation means acceptance of conditions.

3.02 FIELD MEASUREMENTS

Verify all opening dimensions in the field prior to fabrication and assembly of frames.

3.03 INSTALLATION

- A. Install steel doors, frames, and accessories according to shop drawings, manufacturer's data, and as specified.
- B. Comply with provisions of SDI-105, "Recommended Erection Instructions for Steel Door Frames," unless otherwise indicated. Set frames accurately in position, plumbed, aligned, and braced securely until permanent anchors are set. After wall construction is completed, remove temporary braces and spreaders, leaving surfaces smooth and undamaged.
  - 1. Except for frames located in existing concrete, masonry, or gypsum board assembly construction, place frames before constructing enclosing walls and ceilings.
  - 2. In masonry construction, install at least 3 wall anchors per jamb adjacent to hinge location on hinge jamb and at corresponding heights on strike jamb. Acceptable anchors include masonry wire anchors and masonry T-shaped anchors.
  - 3. At existing concrete or masonry construction, install at least 3 completed opening anchors per jamb adjacent to hinge location on hinge jamb and at corresponding heights on strike jamb. Set frames and secure to adjacent construction with bolts and masonry anchorage devices.
  - 4. In metal-stud partitions, install at least 3 wall anchors per jamb at hinge and strike levels. In steel-stud partitions, attach wall anchors to studs with screws.
  - 5. Install fire-rated frames according to NFPA 80.
- C. Fit hollow-metal doors accurately in frames, within clearances specified in ANSI/SDI 100. Install fire rated doors with clearances specified in NFPA 80.

3.04 ADJUST AND CLEAN

- A. Immediately after erection, sand smooth all rusted and damaged areas of prime coat, and apply touch-up of compatible air-drying primer.
- B. Immediately before final inspection, remove protective wrappings from doors and frames.
- C. Final adjustments:
  - 1. Check and readjust operating finish hardware items in hollow metal work just prior to final inspection.
  - 2. Leave work in complete and proper operating condition.
  - 3. Remove defective work and replace with work complying with the specified requirements.

**\*\*\* END OF SECTION \*\*\***

## SECTION 08 14 00

### WOOD DOORS

#### PART 1 GENERAL

##### 1.1 SUMMARY

###### A. Section Includes:

1. Prefinished standard and fire rated type wood doors with flush faces.
2. Prefit and premachine pre-finished wood doors.

###### B. Related Sections:

1. Section 06 10 00 - Rough Carpentry
2. Section 08 10 00 - Hollow Metal Doors and Frames
3. Section 08 71 00 – Finish Hardware
4. Section 08 80 00 - Glazing: Glass and glazing for doors.
5. Section 16 40 00 - Low Voltage Distribution

##### 1.2 REFERENCES

- A. American National Standards Institute (ANSI) 1. A115-W – 1995, WOOD DOOR HARDWARE STANDARDS Hardware Preparations. 2. A117.1 – 1998, Accessible and Usable Buildings and Facilities.
- B. American Society for Testing and Materials (ASTM) 1. ASTM E 119-00a, Standard Test Methods for Fire Tests of Building Construction and Materials.
- C. Door and Hardware Institute (DHI) 1. Locations for architectural hardware for standard steel doors and frames, 1990. 2. Sequence and format for the hardware schedule, January 1996. 3. Hardware for Labeled Fire Doors, February 1993 edition. 4. Hardware for Health Care Facilities, June 1983. 5. Abbreviations and Symbols, September 1983.
- D. HPVA – Hardwood and Plywood Veneer Association.
- E. International Building Code (IBC 2006)
- F. National Electrical Manufacturers Association (NEMA)
- G. National Fire Protection Association (NFPA) 1. NFPA-80 Standard for Fire Doors and Windows, 2007 edition. 2. NFPA-80A Recommended Practice for Protection of Buildings from Exterior Fire Exposures, 2001 edition. 3. NFPA-101 Life Safety Code, 2006 edition. 4. NFPA-101A Guide on Alternative Approaches to Life Safety, 2001 edition. 5. NFPA-101B Code for Means of Egress for Buildings and Structures, 1999 edition. 6. NFPA-105 Recommended Practice for the Installation of Smoke-Control Door Assemblies, 1999 edition. 7. NFPA-252 Standard Methods of Fire Tests of Door Assemblies, 1999 edition.
- H. Steel Door Institute (SDI) 1. SDI-105-98 Recommended Erection Instructions for Steel Frames. 2. SDI-117-93 Manufacturing Tolerances for Standard Steel Doors and Frames. 3. SDI-122-99 Installation and Troubleshooting Guide for Standard Steel Doors and Frames. 4. SDI-124-98 Maintenance of Standard Steel Doors and Frames.
- I. Underwriters Laboratories (UL) 1. UL 10C/UBC7-2-97 Fire Tests of Door Assemblies Positive Pressure 2. UL 1784-90 Air Leakage Tests of Door Assemblies 3. Door Assemblies Air Leakage Test (1784-90)
- J. Uniform Building Code (UBC): 1. UBC 7-2 1997, Fire Test of Door Assemblies.
- K. Window and Door Manufacturers Association (WDMA) 1. IS 1-A 2011 Industry Standard for Architectural Flush Wood Doors.

### 1.3 SUBMITTALS

#### A. General Requirements:

1. Scope of work is to provide flush wood doors in compliance with the approved shop drawings, approved finish hardware schedule and approved door and frame schedule.
2. Wood doors to meet positive pressure Category A or B requirements (as required by specification).

#### B. Shop Drawings and Product Data:

1. Submit in accordance with Section 01330.
2. Indicate general construction, jointing methods, hardware and louver locations, and locations of cutouts for glass. Indicate thickness of veneers.
3. Provide 6 copies of the approved door and frame schedule in the DHI horizontal format with shop drawings.

#### C. Schedules:

1. Provide door and frame schedule in the DHI horizontal format. 2. Door and frame schedule to be prepared by a CDC (Certified Door Consultant) or someone of comparable experience.

#### D. Product Data:

1. Provide catalog cuts of each item.

#### E. Samples:

1. Submit samples of wood veneer and factory finishing in accordance with WDMA Quality Standards I.S. 1-A 2011, sections G-18 and Guide Specifications 1.03 C.
2. Submit 12" x 12" corner sample of each different type of door, .i.e. PC, SCL, FD1.

#### F. Wiring Diagrams:

1. Provide riser diagrams for electrified hardware and coordinate with electrical.
2. Show conduit in shop drawings and reference in door and frame schedule.

#### G. Operations and Maintenance Data: At date of acceptance provide owner with 1 copy of an owners Operations and Maintenance Manual. This manual is to be a 3 ring loose leaf binder with the project name and address on the front cover and spine. In this manual are to be 1 copy of the following items:

1. As Built Door & Frame Schedule.
2. As Built Shop Drawings.
3. As Built Finish Hardware Schedule.
4. Wood Door Manufacturer's Installation Instructions.
5. Section 08110 Standard Steel Doors and Frames.
6. Section 08210 Flush Wood Doors.
7. Section 08710 Finish Hardware.
8. Each related specification Section.
9. Name, address and phone number of the wood door manufacturer.
10. Name, address and phone number of the local manufacturers representative.
11. Name, address and phone number of the material supplier and contact person.

12. Manufacturers care and maintenance instructions.
13. Executed warranty (s).
14. Manufacturers Safety Data Sheets (MSDS) showing compliance to EPA requirements for lead lined doors and frames.
15. Field test data for lead lined doors and frames (to prove EPA compliance).

H. Certification:

1. Submit certification that doors and frames comply with applicable local codes.

1.4 QUALITY ASSURANCE

- A. Fire-Rated Wood Doors: Provide wood doors which are identical in materials and construction to units tested in door and frame assemblies in accordance NFPA 252 and which are labeled and listed for ratings indicated by ITS – Warnock Hersey, UL or other testing and inspection agency acceptable to authorities having jurisdiction.
  1. Doors: Comply with UBC 7-2 1997 where required. 2. Provide intumescent requirements in compliance with UL-10C Category A or B. 3. Provide doors that comply with UL10C Category B and coordinate with Section 08710 for applied Category G sealing systems. (Architect to choose category A or B)
- B. WDMA I.S. 1-A 2011 Quality Standard: Window and Door Manufacturers Association Quality Standards for grade of door, core, construction, finish, and other requirements.
- C. Temperature Rise Rating: At stairwell enclosures, provide doors which have Temperature Rise Rating of 250 degrees F maximum in 30 minutes of fire exposure.
- D. Supplier Qualifications: Supplier to have a full time Certified Door Consultant (CDC) on staff or some of comparable experience. Supplier shall have warehousing and office facilities within 100 miles of project. Supplier to have been engaged in this type of business in jobsite area for 3 or more years.
- E. Certification of Label Construction: 1. Intertek Testing, Inc (WHI) 2. Underwriters Laboratories, Inc. (UL) 3. California State Fire Marshal (CSFM)
- F. Substitutions: Apply for substitutions in compliance with the requirements set fourth in Division 1 and no less than 10 business days prior to bid date.

1.5 DELIVERY STORAGE AND HANDLING

- A. Site Conditions: Storage area for wood doors is to be in a dried, conditioned and secure area with controlled and stabilized humidity per manufacturers recommendations.
- B. Marking and Packaging:
  1. Doors to be marked per the approved door and frame schedule.
  2. Prefinished Doors to have 5 mil plastic peel coat applied to both sides.
- C. Delivery: Coordinate delivery with Installer not less than 3 weeks prior to delivery.
- D. Storage:
  1. Follow the Care and Installation guidelines as described in WDMA I.S. 1-A 2011.
  2. Doors are to be stored flat and palletized with not more than 30 door leafs per pallet.
  3. Doors to be a minimum of 6" above floor while in storage.
- E. Handle doors with clean, white soft cotton gloves to prevent contamination by hand oils and dirt. Gloves are to be provided by whomever handles doors at any given time.
- F. Handle doors per manufacturers recommendations.

## 1.6 GUARANTEE/WARRANTY

Guarantee: Provide manufacturer's guarantee for all wood doors. Guarantee period: Lifetime of original installation. Doors exhibiting defects in materials or workmanship including warp and delamination within guarantee period shall be replaced (including hanging and finishing) with new doors. These terms shall be part of the manufacturer's standard warranty.

## **PART 2 -- PRODUCTS**

### 2.1 ACCEPTABLE MANUFACTURERS

- A. Basis of Design: American Series Flush Doors by ABS Manufacturing – 1488 Tillie Lewis Drive – Stockton, CA 95206; 4475 S. Fulton Parkway Building 6 Suite# 200 – Union City, GA 30349; Phone: (888) 4542888; Fax (888) 454-2889.
- B. Eggers Industries, Two Rivers, WI (920)793-1351
- C. Oregon Door, 477 Dillard Gardens Rd., Dillard, OR 97432 (800)-722-7269
- D. Or Architect approved equal.

### 2.2 MATERIALS

#### A. Door Construction

- 1. Non-Fire Rated Doors: Thickness: 1-3/4 inches, interior flush wood, bonded, solid core conforming to WDMA I.S. 1-A 2011 and the following;
  - a. Core: bonded particle core (PC) or structural composite lumber (SCL) conforming to WDMA I.S. 1-A 2011.
  - b. Door construction shall conform to WDMA I.S. 1-A 2011 Premium Grade requirements.
  - c. Stiles: Hardwood to match face veneer over structural composite lumber (SCL), glued to core. Minimum stile thickness of 1 3/8".
  - d. Rails: Mill option hardwood or SCL. Top and bottom: minimum of 1 1/8" inches.(MDF)
  - e. Facing: Wood veneer as specified.
  - f. Acceptable manufacturers and products: Manufacturer PC Core SCL Core GP Core EX Core American HD-NL EHD-NL STC-43 STC-45 Eggers PC-5 SCL-5 STC-43 STC-45 Oregon PC-5 SCL-5
- 2. 20 minute Rated Doors: Thickness: 1-3/4 inches, interior flush wood, bonded, solid core conforming to WDMA I.S. 1-A 2004 and the following;
  - a. Core: bonded particle core (PC) or structural composite lumber (SCL) conforming to WDMA I.S. 1-A 2011.
  - b. Door construction shall conform to WDMA I.S. 1-A 2011 Premium Grade requirements.
  - c. Stiles: Hardwood to match face veneer over mineral composite, glued to core.
  - d. Rails: Mineral composite as required by fire door authorities. Top and bottom: as required by manufacturer's fire door authorities.
  - e. Facing: Wood veneer as specified.
  - f. Frame Applied Seals: Provide smoke seals by others as required to meet labeling requirements.



- g. Acceptable manufacturers and products: Manufacturer 20 min. PC 20 min. SCL American HD- 20B EHD- 20B American HD- 20A EHD- 20A Eggers PC-5 20B SCL-5 20B Eggers PC-5 20A SCL-5 20A Oregon PC-5 20B SCL-5 20B Oregon PC-5 20A SCL-5 20A
3. Fire Rated Doors: Thickness: 1-3/4 inches, interior flush wood, bonded, solid core conforming to WDMA I.S. 1-A 2004 and the following;
    - a. Core: bonded mineral core (FD) conforming to WDMA I.S. 1-A 2011.
    - b. Door construction shall conform to WDMA I.S. 1-A 2011 Premium Grade requirements.
    - c. Stiles: Hardwood to match face veneer over mineral composite, glued to core.
    - d. Rails: Mineral composite as required by fire door authorities. Top and bottom: as required by manufacturer's fire door authorities.
    - e. Facing: Wood veneer as specified.
    - f. Frame Applied Seals: Provide Category G seals by others as required to meet labeling requirements.
    - g. Acceptable manufacturers and products: Manufacturer FD 3/4 FD1 FD 1 ½ American MC 45B MC 60B MC 90B American MC 45A MC 60A MC 90A Eggers FD-45B FD-60B FD-90B Eggers FD-45A FD-60A FD-90A Oregon FD-45B FD-60B FD-90B Oregon FD-45A FD-60A FD-90A

B. Wood Veneer

1. Door face veneers shall meet HPVA "A" grade quality standards conforming to WDMA I.S. 1-A for transparent or semi-transparent finish. Minimum face veneer thickness shall be 1/42" at 12% moisture content after finish sanding.
2. Species: White Oak
3. Face Cut: Plain Sliced, Rift cut
4. Face Assembly: Book Match / Slip Match / Random Match. (TBD)
5. Face Symmetry: Running Match / Balanced Match / Center Balanced Match. (TBD)
6. Precondition raw veneer prior to applying top coat.

C. Adhesives

1. Adhesives: Face to core adhesives shall be Type I. Adhesives must be classified Type I per WDMA TM-6 "Adhesive Bond Test Method."

D. Core

1. Non-rated and 20 minute doors: Solid particleboard ANSI 208.1-LD-2, SCL, or Agri-Fiber ANSI 208.1-LD-1.
2. Fire-rated doors: Non-combustible mineral core containing no asbestos.

2.3 FACTORY FINISHING

- A. Comply with referenced WDMA Section G-15, "Factory Finishing."
- B. Pre-finish wood doors at factory.
- C. Transparent Finish: Match finish indicated in WDMA Section G-17: WDMA System #6.

2.4 ACCESSORIES

- A. Metal Louvers:

1. General: Provide Minimum 18-gauge louver frame with minimum 22-gauge louver blades. Louver blades to be sight proof inverted Y type. Provide galvanized insect screen at exterior locations. At exterior and wet areas provide A60 or G60 louvers.
  2. Non-rated doors: Provide Anemostat, Air Louvers, All Metal Stamping
  3. Fire-rated Doors: Provide fusible link louver by Anemostat, All Metal Stamping, Air Louvers.
  4. Fasteners: Provide manufacturers standard mechanical fasteners. Exposed fasteners to be on secure side of door.
- B. Wood Vision Frames:
1. General: Wood, of the same species/compatible with door species
  2. Non-Rated: W9 Flush/W7 Lip beading wood of the same species/compatible with door species.
  3. Fire-Rated
- C. Metal Vision Frames:
1. General: Provide minimum 20-gauge vision frames that protrude no more than 5/64" over face of frame. At exterior and wet areas provide A60 or G60 vision frames.
  2. Non-rated doors: Provide Anemostat, Air Louvers, All Metal Stamping metal vision frame.
  3. Labeled Doors: Provide Anemostat, Air Louvers, All Metal Stamping metal vision frame with glazing tape.
  4. Fire-rated doors: ITS – Warnock Hersey or UL approved glazing system.
  5. Glass: Refer to Section 08810 for glass types and thickness.
  6. Fasteners: Provide manufacturers standard mechanical fasteners. Exposed fasteners to be on secure side of door.

## 2.5 FABRICATION

- A. Fabricate wood doors in accordance with requirements of WDMA I.S. 1-A 2011 Quality Standards.
- B. Fabricate fire rated doors in accordance with requirements of ITS – Warnock Hersey, Underwriters' Laboratories, or California State fire Marshall with metal label on each door including UL-10C.
- C. Provide blocking for hardware per hardware manufacturers requirements for hardware to be installed without thru-bolts on all mineral core doors where locks, closers, panics and or kick plates are installed.
- D. Fabricate doors with WDMA Quality Standards hardware blocking options as follows:
  1. Provide HB-1 – head and HB-2 – sill rails and HB-4 – lock block on all doors.
  2. Provide HB-6 only when exit devices are specified for door.
  3. Provide HB-8 for pivots or when floor bolts are specified under Section 08710 – Finish Hardware.
- E. Non-rated and 20-minute rated shall have vertical edges that shall be veneer banded stiles (or) optional 2-ply solid wood 7/16 prior to bevel
- F. Make cutouts and provide stops for glass and louvers. Install metal door louvers. Seal cut-outs prior to installation of moldings.
  1. For full light doors: Provide cut out from flush wood door, with vertical grain direction.

- G. Bevel lock and hinge edges of single acting doors 3 degrees or 1/8 inch in 2 inches. Radius strike edge of double acting swing doors as required by pivot hinge manufacturer.
- H. Prepare doors to receive hardware. Refer to Section 08710 - Hardware and NFPA 80 for hardware requirements including UL-10C.
  - 1. Prefit and bevel to net opening size less approximately 1/4 inch in width on single swing doors 3/16" inch in width for paired doors. Provide clearance based on NFPA-80 allowable clearances above finished floor, unless otherwise indicated on drawings. Provide 1/8 inch clearance at top of door.
  - 2. Slightly ease vertical edges. 3. Predrill pilot holes for all butt hinge mortise preps.
- I. Fire Rated Pair of Doors; greater than 20 minute: Supply overlapping astragals or metal edge sets only as required by NFPA 80 1999 or by door manufacturer's fire door authorities. If an astragal is required, to comply with fire rated labeling requirements for pairs of fire rated doors, provide door manufacturer's standard tested astragal as required. No Metal Edges or astragal required for 20minute rated pairs.

## 2.6 SOURCE QUALITY CONTROL

- A. Inspect doors prior to shipment, any doors that are damaged, not machined properly or defective shall be repaired to manufacturers quality standards for new doors or be replaced prior to shipment.

## **PART 3 EXECUTION**

### 3.1 EXAMINATION

- A. Examine installed door frames before hanging doors and notify the general contractor of any or all discrepancies.
- B. Verify that frames comply with indicated requirements for type, size, location, and swing characteristics and have been installed with plumb jambs and level heads.
- C. Proceed with installation only after unsatisfactory conditions have been corrected.
- D. Inspect jobsite to ensure a dry and secure area that meets manufacturers storage recommendations is available and ready to receive the doors prior to delivery of doors.

### 3.2 PREPARATION

Prior to delivery of wood doors, and while wood doors are being stored, the storage area shall:

- A. Be free of all trash and debris.
- B. Meet manufacturer's recommendations for storage of wood doors.
- C. Be conditioned and have stabilized humidity control.

### 3.3 INSTALLATION

- A. Handle doors in accordance with recommendations of WDMA I.S. 1-A, "Care and Installation at Job Site."
- B. Condition doors to average temperature and humidity in area of installation for not less than 48 hours prior to installation. Store doors per recommendations of WDMA I.S. 1-A, "Care and Installation at Job Site."
- C. Install in neat and workmanlike manner, free from hammer or tool marks, open joints or slivers.
- D. Set plumb, level, square and true. Install doors after building humidity is at acceptable level.
- E. Remove and replace all warped, twisted, bowed, or otherwise damaged doors. Do not install doors that cannot be properly fitted to frames.

- F. Adjust prefinished doors and hardware and other moving or operating parts to function smoothly and correctly.
- G. If doors are to be field finished, the process must follow the WDMA I.S. 1-A, "Care and Handling at Job Site" instructions for field applied finishes.
- H. Ensure that smoke gaskets are in-place before prefinished door installation.
- I. Ensure that all seals and gaskets are in-place before STC door installation.
- J. Protect the work of other trades damage from the installation of doors and frames.
- K. Install doors in accordance with the following:
  - 1. Manufacturer's instructions, recommendations and tolerances.
  - 2. NFPA-80
  - 3. SDI-105
  - 4. Approved Finish Hardware Schedule
  - 5. Approved Door and Frame Schedule
  - 6. Approved Shop Drawings
  - 7. All applicable codes and requirements

### 3.4 FIELD QUALITY CONTROL

- A. Lead lined openings are to be field tested by a certified independent testing agency. Any problems are to be corrected prior to the field inspection.
- B. Test all openings with electrified hardware after installation to ensure proper operation.
- C. Manufacturer's representative to inspect the jobsite upon substantial completion and provide a written report on any problems on the project. Provide 1 copy of this report to the material supplier, general contractor, architect, installer and the owner.
- D. All discrepancies listed in the report are to be corrected prior to final acceptance.

### 3.5 ADJUSTING AND CLEANING

Prior to final acceptance and at no additional cost to owner:

- A. Adjust doors to meet required tolerances.
- B. General Contractor to clean doors per manufacturer's instructions to be free from all foreign materials.
- C. Repair damaged doors per manufacturer's instructions and guidelines.
- D. Replace damaged doors that cannot be repaired to the manufacturers standards of quality.
- E. Replace defective doors.

### 3.6 DEMONSTRATION

- A. Demonstrate and explain the operation of automatic doors to the building maintenance director and chief engineer prior to final acceptance.

### 3.7 PROTECTION

- A. Keep poly bags on doors until date of acceptance.
- B. Protect doors from damage by other trades.
- C. Keep area around doors free from trash and debris.
- D. At unfinished and clear finished doors, do not partially cover door surfaces with paper, cardboard, or any other opaque covering that will create uneven aging of wood veneer.

E. Protect doors as directed under Section 01700.

**\*\*\*END OF SECTION\*\*\***

**THIS PAGE IS INTENTIONALLY BLANK**

## SECTION 08 41 13

### ALUMINUM ENTRANCE AND FRAMING SYSTEMS

#### **PART 1 -- GENERAL**

##### 1.01 SUMMARY

Division 0, Contract Requirements and Division 1, General Conditions apply to this Section.

##### 1.02 SCOPE OF WORK

Furnish materials and perform labor required to execute this work as indicated on the drawings, as necessary to comply with the Contract Documents, including, but not limited to, these major items:

1. Aluminum framing systems.
2. Aluminum framed doors including push-pull bars, seals and cylinder locks for use during construction only. Verify size of opening with hardware supplier.
3. Sealant around all exterior aluminum frames.

##### 1.03 SUBSTITUTIONS

Substitutions will be considered per the Instructions to Bidders, Section 3.3 Substitutions.

##### 1.04 SUBMITTALS

- A. In accordance with Article 3 of the General Conditions.
- B. Product data: Within 35 calendar days after the Contractor has received the Owner's Notice to Proceed, submit:
  1. Materials list of items proposed to be provided under this Section:
  2. Manufacturer's specifications and other data needed to prove compliance with the specified requirements.
  3. Shop Drawings showing details of each frame type, elevations of door designs, details of openings, and details of construction, installation, and anchorage.
  4. Manufacturer's recommended installation procedures which, when accepted by the Architect, will become the basis for accepting or rejecting actual installation procedures used on the Work.
  5. Samples of material, approximately 4" x 4" in size, of each of the proposed materials.

##### 1.05 PRODUCT HANDLING

Lift doors and carry them into position. Do not drag doors across one another.

##### 1.06 WARRANTY

- A. Aluminum Anodized Finish: Two year warranty shall be required to cover all defects including but not limited to the following:
  1. Fading
  2. Pinholing
  3. Blistering
  4. Changes in surface appearance and characteristic

- B. Exterior storefronts: Warrant entire installation including glazing and caulking to remain watertight, airtight, and weathertight for two (2) years.
- C. Entrance Doors: Warrant against sagging or twisting as a result of normal usage for the lifetime of this installation.

#### 1.07 GUARANTEE

Contractor guarantees the work covered by this specification against all defects in material and workmanship for a period of not less than two (2) years from the date the Owner records Notice of Completion.

### **PART 2 -- PRODUCTS**

#### 2.01 MATERIALS

- A. All door and frame sections shall be extruded aluminum AA-6063-T5 alloy; aluminum sheet used to complement the framing system shall be of proper alloy to receive anodic treatment and match the job finish.
- B. Finishes: All exposed surfaces shall be smooth and free of distracting scratches and blemishes. Color shall conform to Aluminum Association Standards of Architectural Class I anodic coding and shall be designated as Premium (Custom) color to be specified by Architect.

#### 2.02 ALUMINUM STOREFRONT FRAMES

- A. Construction and Design: All mullions shall have a 2" face dimension x 4-1/2" depth and be designed for exterior glazing. At sill and intermediate horizontal locations, members shall be of two-piece constructions: a basic base member with a snap-in glass stop to facilitate glazing. Vertical mullions shall be have one or two-piece construction, located within the framing system so as to have the deep glazing pocket of the adjacent mullion. Jambes are to be open-back mullions. Continuous aluminum flashing shall be installed under all sill members. Seals shall be provided for weathertight installation of frames and doors.
- B. All frames shall be Trifab II 451 for dual paned glazing as manufactured by Kawneer Company, Inc. or approved equal.

#### 2.03 ALUMINUM ENTRANCE

- A. All aluminum entrances shall be the 190-entrance door as manufactured by Kawneer, with 2-1/8" vertical style, 2-1/4" top rail and 12" bottom rail.
- B. Weathering shall be Kawneer, Sealair polymeric weathering system. The bottom rail shall be weathered with EPDM blade gasket sweep strip.
- C. Door shall be equipped with Panic Guard astragal with Paneline II concealed rod exit device mounted in cross-rail, unless indicated otherwise in the Hardware Specification. The cylinder mounting in the style plate to be in such a way that removal with door closed is impossible.
- D. Provide LCN 2030 concealed overhead closure with hold open, unless indicated otherwise in the Hardware Specification. Door supplier to be responsible for complete installation of all hardware on the storefront system.
- E. All vertical and horizontal door sections shall be installed so as to receive infill thicknesses as dictated in the glass and glazing sections of the Specifications. Square aluminum horizontal, snap-in glass stops and sloping, aluminum vertical snap-in glass stops, with a lock-in vinyl system, shall be provided to accommodate specified infill thickness (1" thick glazing).



- F. Hardware coordination:
  - 1. The finish hardware cylinder shall be coordinated with the hardware supplier.
  - 2. Provide a 1/2" x 6-3/4" aluminum finish threshold unless indicated otherwise in the Hardware specification.
  - 3. Hardware information shall be received prior to fabrication to insure proper detailing and scheduling.

### **PART 3 -- EXECUTION**

#### **3.01 EXAMINATION**

- A. Examine the areas and conditions under which work of this Section will be performed.
- B. Correct conditions detrimental to timely and proper completion of the Work.
- C. Do not proceed until unsatisfactory conditions are corrected.
- D. Beginning of installation means acceptance of conditions.

#### **3.02 PREPARATION**

- A. Verify wall openings and adjoining air and vapor seal materials are ready to receive work of this Section.
- B. Field Conditions: Verify drawing dimensions with actual field conditions prior to fabrication. Report any condition, which would prevent proper execution of this contractor's work to the project manager.

#### **3.03 INSTALLATION OF ENTRANCE AND WINDOW FRAMING**

- A. Accurately cut and install all aluminum and glass in accordance with manufacturer's instructions and with applicable requirements of "Glazing Manual", issued by Flat Glass Manufacturer's Association.
- B. Use anchorage devices to securely attach frame assembly to structure.
- C. Align assembly plumb and level, free of warp or twist. Maintain assembly dimensional tolerances, aligning with adjacent work (0.03" per foot max. or 0.25" per 30 feet, whichever is less).
- D. Installation of structural silicone and backing materials shall be in accordance with silicone manufacturer's requirements. All joints between framing and the building structure shall be sealed in order to secure a watertight installation.
- E. Coordinate attachment and seal of air and vapor barrier materials. Pack fibrous insulation in shim spaces at perimeter of assembly to maintain continuity of thermal barrier.
- F. Install hardware and glass per other sections of these Specifications.

#### **3.04 CLEANING AND POLISHING**

- A. Care and Maintenance: It will be the responsibility of the Contractor to protect material from mortar, paint, plaster, terrazzo, etc., during construction, and to thoroughly clean doors and frames before the Owner takes possession.
- B. Remove protective material from pre-finished surfaces using a solution of mild detergent in warm water, applied with soft clean wiping cloths.
- C. Remove excess sealant by moderate use of mineral spirits or other solvent acceptable to sealant manufacturer.
- D. Final cleaning and polishing shall be done prior to final inspection.

**\*\*\*END OF SECTION\*\*\***

**THIS PAGE IS INTENTIONALLY BLANK**

## SECTION 08 53 13

### INTERIOR ALUMINUM DOOR AND WINDOW FRAMES

#### **PART 1 - GENERAL**

##### 1.01 SUMMARY

Division 0, Contract Requirements and Division 1, General Conditions apply to this Section.

##### 1.02 SCOPE OF WORK

###### A. Section includes:

1. Pre-finished aluminium door frames for interior use.
2. Pre-finished aluminium window frames for interior use.

###### B. Related sections:

1. Section 08 10 00 – Metal Doors and Frames
2. Section 08 14 00 – Wood doors and frames
3. Section 08 71 00 – Finish Hardware
4. Section 08 80 00 – Glazing

##### 1.03 SUBMITTALS

A. Provide in accordance with Article 3.11 of the General Conditions.

B. Product data: Manufacturer's fabrication and installation instructions.

1. Include information on factory finish, glazing gaskets, accessories and other required components.

C. Shop drawings: Submit schedule indicating opening numbers, frame types, dimensions, swings and hardware requirements.

D. Include elevations and details indicating frame types, profiles, conditions at openings, methods and locations of anchoring, glazing requirements, hardware locations and reinforcements for hardware.

E. Samples: Submit the following:

1. Full range of manufacturer's standard finishes for the Architect's selection.
2. Where normal color variations are expected, include additional samples to show range of such variation.

F. Instructions: Provide copies of manufacturer's data for fabrication and installation of aluminium door frames.

##### 1.04 SUBSTITUTIONS

Substitutions will be considered per the Instructions to Bidders, Section 3.3 Substitutions.

##### 1.05 QUALITY ASSURANCE

A. Single Source Responsibility: Provide aluminium frames, aluminium and glass doors and accessories produced by a single manufacturer for each type of product indicated.

B. Manufacturer's qualifications: Company specializing in the manufacturing of door frame systems with a minimum of 10 years of documented experience on a comparable sized project.

C. Fire and smoke rated assemblies:

1. In locations where fire rated openings are scheduled or required by regulatory agencies, provide fire rated aluminium frames that have been tested and certified for specified exposure by an agency acceptable to governing authorities.
2. Provide labels permanently fastened on each fire rated frame that are within size limits established by NFPA and the testing authority.
  - A. Provide 20 minute labels.
  - B. Provide 90 minute labels.

1.06 DELIVERY, STORAGE AND HANDLING

- A. Deliver frames and doors cartoned to provide protection during transit and storage at project site.
- B. Inspect frames and doors upon delivery for damage.
  1. Repair minor damage to pre-finished products by means as recommended by the manufacturer.
  2. Replace frames that cannot be satisfactorily repaired.
- C. Store frames at the project site under cover and as near as possible to the final installation location. Do not use covering material that will cause discoloration of aluminium finish.

1.07 ENVIRONMENTAL REQUIREMENTS

- A. Do not begin installation of the frames or doors until the area of work has been completely enclosed and the interior is protected from the elements.
- B. Maintain temperature and humidity in areas of installation within reasonable limits, as close as possible to final occupancy. If necessary, provide temperature control and ventilation to maintain required environmental conditions.

1.08 WARRANTY

- A. Warrant against defects in manufacturing of materials for a period of 2 years from date of substantial completion.
- B. Warrant framing finish against defects, including cracking, flaking, blistering, peeling and excessive fading, chalking and non-uniformity in color for a period of 5 years.

**PART 2 - PRODUCTS**

2.01 PRODUCT

Basis of Design: Wilson Partitions, 2301 E. Vernon Avenue, Vernon, CA 90058; Phone: (866) 443-7258; Fax: (323) 908-5451.

2.02 MATERIALS

Aluminium: Controlled alloy billets meeting requirements of ASTM B221, 6063 T5 alloy, to assure compliance with tight dimensional tolerances and maintain color uniformity.

2.03 EXTRUDED ALUMINUM FRAMES

- A. Provide frames with the following characteristics:
  1. Rectilinear design.
  2. Trim: 1", 1-1/4", 1-1/2", 2", 3", 4" and 6".
  3. Series 375: 3-3/4" throat.
  4. Series 487: 4-7/8" throat.

5. Series 525: 5-1/4" throat.
6. Series 725: 7-1/4" throat.
7. Series 200: expandable throat from 3" up to 9-1/2".
8. Accepts 1/4" and 3/8" Glass.

2.04 FABRICATION

- A. Pre-machine jambs and prepare for hardware, with concealed reinforcement plates, drilled and tapped as required, and fastened within the frame.
- B. Provide corner reinforcements and alignment clips for precise butt or mitered connections.
- C. Fabricate all components to allow secure installation without exposed fasteners.
- D. Manufacturer shall pre-cut and ship all frame materials knock-down.

2.05 FINISHES

- A. Factory finish extruded frame components so that any part exposed to view upon completion of installation will be uniform in finish and color.
- B. Clear Anodic Coating (AC-2): Comply with AAMA 611.
  1. Commercial, AAM12C22A21 anodized coating, less than .04 mil minimum thick.
- C. Light Champagne Anodic Coating (AB-1), Champagne Anodic Coating (AB-2), Light Bronze Anodic Coating (AB-3), Medium Bronze Anodic Coating (AB-4), Standard Medium Bronze Anodic Coating (AB-5), Dark Bronze Anodic Coating (AB-6), Standard Dark Bronze Anodic Coating (AB-7), Black Anodic Coating (AB-8): Comply with AAMA 611.
  1. Class II, AAM12C22A34 anodized coating, 0.4 mil minimum thick.
- D. Fluorocryl Coating: Comply with AAMA (2603) 603.8 and AA-DAF-45.
  1. Factory applied painted finish.
  2. Color coat: Dry film thickness 0.8 +/- 0.05 mil.
  3. Color: As selected by Architect.
    - A. Manufacturer's standard Tan, White, Grey, Bronze or Black.
    - B. Custom color to match Architect's sample.

**PART 3 - EXECUTION**

3.01 EXAMINATION

- A. Examine project conditions and verify that the work of this section may properly commence. Do not proceed with the installation until unsatisfactory conditions have been corrected.
- B. Verify that the wall thickness does not exceed manufacturer's recommended tolerances of specified frame throat size.

3.02 INSTALLATION

- A. Comply with frame manufacturer's printed installation instructions and approved shop drawings. Strictly adhere to maintaining specified wall thickness to insure dimension does not exceed frame throat size specified. Installation not to be attempted in areas where the wall thickness exceeds the tolerance of the specified throat size.
- B. Install frames plumb and square, securely anchored to substrates with fasteners recommended by frame manufacturer.

1. Use concealed installation clips to assure that splices and connections are tightly butted and properly aligned.
2. Secure clips to main structural extrusion components and not to snap-in or trim members.
3. Do not use screws or other fasteners that will be exposed to view when installation is complete.

3.03 ADJUSTING AND CLEANING

- A. Clean exposed frames promptly after installation, using cleaning methods recommended by frame manufacturer.
- B. Touch up marred areas so that touch-up is not visible from a distance of 4 feet. Remove and replace frames that cannot be satisfactorily adjusted.

3.04 PROTECTION

- A. Provide protection required to assure that frames will be without damage or deterioration upon substantial completion of the project.

**\*\*\* END OF SECTION \*\*\***

## SECTION 08 71 00

### FINISH HARDWARE

#### **PART 1 - GENERAL**

##### 1.1 RELATED DOCUMENTS

- A. Drawings and general provisions of the Contract, including General and Supplementary Conditions and Division 01 Specification Sections, apply to this Section.

##### 1.2 SUMMARY

- A. Section includes:
  - 1. Mechanical and electrified door hardware for:
    - a. Swinging doors.
- B. Exclusions: Unless specifically listed in hardware sets, hardware is not specified in this section for:
  - 1. Windows
  - 2. Cabinets (casework), including locks in cabinets
  - 3. Signage
  - 4. Toilet accessories
  - 5. Overhead doors
- C. Related Sections:
  - 1. Division 01 Section "Alternates" for alternates affecting this section.
  - 2. Division 07 Section "Joint Sealants" for sealant requirements applicable to threshold installation specified in this section.
  - 3. Division 09 sections for touchup finishing or refinishing of existing openings modified by this section.

##### 1.3 REFERENCES

- A. UL - Underwriters Laboratories
  - 1. UL 10B - Fire Test of Door Assemblies
  - 2. UL 10C - Positive Pressure Test of Fire Door Assemblies
  - 3. UL 1784 - Air Leakage Tests of Door Assemblies
  - 4. UL 305 - Panic Hardware
- B. DHI - Door and Hardware Institute
  - 1. Sequence and Format for the Hardware Schedule
  - 2. Recommended Locations for Builders Hardware
  - 3. Key Systems and Nomenclature
- C. ANSI - American National Standards Institute
  - 1. ANSI/BHMA A156.1 - A156.29, and ANSI/BHMA A156.31 - Standards for Hardware and Specialties

##### 1.4 SUBMITTALS

- A. General:
  - 1. Submit in accordance with Conditions of Contract and Division 01 requirements.
  - 2. Highlight, encircle, or otherwise specifically identify on submittals deviations from Contract Documents, issues of incompatibility or other issues which may detrimentally affect the Work.

3. Prior to forwarding submittal, comply with procedures for verifying existing door and frame compatibility for new hardware, as specified in PART 3, "EXAMINATION" article, herein.
- B. Action Submittals:
1. Product Data: Product data including manufacturers' technical product data for each item of door hardware, installation instructions, maintenance of operating parts and finish, and other information necessary to show compliance with requirements.
  2. Samples for Verification: If requested by Architect, submit production sample or sample installations of each type of exposed hardware unit in finish indicated, and tagged with full description for coordination with schedule.
    - a. Samples will be returned to supplier in like-new condition. Units that are acceptable to Architect may, after final check of operations, be incorporated into Work, within limitations of key coordination requirements.
  3. Door Hardware Schedule: Submit schedule with hardware sets in vertical format as illustrated by Sequence of Format for the Hardware Schedule as published by the Door and Hardware Institute. Indicate complete designations of each item required for each door or opening, include:
    - a. Door Index; include door number, heading number, and Architects hardware set number.
    - b. Opening Lock Function Spreadsheet: List locking device and function for each opening.
    - c. Type, style, function, size, and finish of each hardware item.
    - d. Name and manufacturer of each item.
    - e. Fastenings and other pertinent information.
    - f. Location of each hardware set cross-referenced to indications on Drawings.
    - g. Explanation of all abbreviations, symbols, and codes contained in schedule.
    - h. Mounting locations for hardware.
    - i. Door and frame sizes and materials.
    - j. Name and phone number for local manufacturer's representative for each product.
    - k. Operational Description of openings with any electrified hardware (locks, exits, electromagnetic locks, electric strikes, automatic operators, door position switches, magnetic holders or closer/holder units, and access control components). Operational description should include how door will operate on egress, ingress, and fire and smoke alarm connection.
    - 1) Submittal Sequence: Submit door hardware schedule concurrent with submissions of Product Data, Samples, and Shop Drawings. Coordinate submission of door hardware schedule with scheduling requirements of other work to facilitate fabrication of other work that is critical in Project construction schedule.
  4. Key Schedule:
    - a. After Keying Conference, provide keying schedule listing levels of keying as well as explanation of key system's function, key symbols used and door numbers controlled.
    - b. Use ANSI/BHMA A156.28 "Recommended Practices for Keying Systems" as guideline for nomenclature, definitions, and approach for selecting optimal keying system.
    - c. Provide 3 copies of keying schedule for review prepared and detailed in accordance with referenced DHI publication. Include schematic keying diagram and index each key to unique door designations.
    - d. Index keying schedule by door number, keyset, hardware heading number, cross keying instructions, and special key stamping instructions.
    - e. Provide one complete bitting list of key cuts and one key system schematic illustrating system usage and expansion.



- 1) Forward bitting list, key cuts and key system schematic directly to County of Riverside, by means as directed by County of Riverside
  - f. Prepare key schedule by or under supervision of supplier, detailing County of Riverside's final keying instructions for locks.
  5. Templates: After final approval of hardware schedule, provide templates for doors, frames and other work specified to be factory prepared for door hardware installation.
- C. Informational Submittals:
1. Qualification Data: For Supplier, Installer and Architectural Hardware Consultant.
  2. Product Certificates for electrified door hardware, signed by manufacturer:
    - a. Certify that door hardware approved for use on types and sizes of labeled fire-rated doors complies with listed fire-rated door assemblies.
  3. Certificates of Compliance:
    - a. Certificates of compliance for fire-rated hardware and installation instructions if requested by Architect or Authority Having Jurisdiction.
    - b. Installer Training Meeting Certification: Letter of compliance, signed by Contractor, attesting to completion of installer training meeting specified in "QUALITY ASSURANCE" article, herein.
    - c. Electrified Hardware Coordination Conference Certification: Letter of compliance, signed by Contractor, attesting to completion of electrified hardware coordination conference, specified in "QUALITY ASSURANCE" article, herein.
  4. Product Test Reports: For compliance with accessibility requirements, based on evaluation of comprehensive tests performed by manufacturer and witnessed by qualified testing agency, for door hardware on doors located in accessible routes.
  5. Warranty: Special warranty specified in this Section.
- D. Closeout Submittals:
1. Operations and Maintenance Data : Provide in accordance with Division 01 and include:
    - a. Complete information on care, maintenance, and adjustment; data on repair and replacement parts, and information on preservation of finishes.
    - b. Catalog pages for each product.
    - c. Name, address, and phone number of local representative for each manufacturer.
    - d. Parts list for each product.
    - e. Final approved hardware schedule, edited to reflect conditions as-installed.
    - f. Final keying schedule
    - g. Copies of floor plans with keying nomenclature
    - h. As-installed wiring diagrams for each opening connected to power, both low voltage and 110 volts.
    - i. Copy of warranties including appropriate reference numbers for manufacturers to identify project.

## 1.5 QUALITY ASSURANCE

- A. Product Substitutions: Comply with product requirements stated in Division 01 and as specified herein.
1. Where specific manufacturer's product is named and accompanied by "No Substitute," including make or model number or other designation, provide product specified. (Note: Certain products have been selected for their unique characteristics and particular project suitability.)
    - a. Where no additional products or manufacturers are listed in product category, requirements for "No Substitute" govern product selection.

2. Where products indicate “acceptable manufacturers” or “acceptable manufacturers and products”, provide product from specified manufacturers, subject to compliance with specified requirements and “Single Source Responsibility” requirements stated herein.
- B. Supplier Qualifications and Responsibilities: Recognized architectural hardware supplier with record of successful in-service performance for supplying door hardware similar in quantity, type, and quality to that indicated for this Project and that provides certified Architectural Hardware Consultant (AHC) available to County of Riverside, Architect, and Contractor, at reasonable times during the Work for consultation.
1. Warehousing Facilities: In Project's vicinity.
  2. Scheduling Responsibility: Preparation of door hardware and keying schedules.
  3. Engineering Responsibility: Preparation of data for electrified door hardware, including Shop Drawings, based on testing and engineering analysis of manufacturer's standard units in assemblies similar to those indicated for this Project.
  4. Coordination Responsibility: Coordinate installation of electronic security hardware with Architect and electrical engineers and provide installation and technical data to Architect and other related subcontractors.
    - a. Upon completion of electronic security hardware installation, inspect and verify that all components are working properly.
- C. Installer Qualifications: Qualified tradesmen, skilled in application of commercial grade hardware with record of successful in-service performance for installing door hardware similar in quantity, type, and quality to that indicated for this Project.
- D. Single Source Responsibility: Obtain each type of door hardware from single manufacturer.
1. Provide electrified door hardware from same manufacturer as mechanical door hardware, unless otherwise indicated.
  2. Manufacturers that perform electrical modifications and that are listed by testing and inspecting agency acceptable to authorities having jurisdiction are acceptable.
- E. Fire-Rated Door Openings: Provide door hardware for fire-rated openings that complies with NFPA 80 and requirements of authorities having jurisdiction. Provide only items of door hardware that are listed and are identical to products tested by Underwriters Laboratories, Intertek Testing Services, or other testing and inspecting organizations acceptable to authorities having jurisdiction for use on types and sizes of doors indicated, based on testing at positive pressure and according to NFPA 252 or UL 10C and in compliance with requirements of fire-rated door and door frame labels.
- F. Smoke- and Draft-Control Door Assemblies: Where smoke- and draft-control door assemblies are required, provide door hardware that meets requirements of assemblies tested according to UL 1784 and installed in compliance with NFPA 105.
1. Air Leakage Rate: Maximum air leakage of 0.3 cfm/sq. ft. (3 cu. m per minute/sq. m) at tested pressure differential of 0.3-inch wg (75 Pa) of water.
- G. Means of Egress Doors: Latches do not require more than 15 lbf (67 N) to release latch. Locks do not require use of key, tool, or special knowledge for operation.
- H. Accessibility Requirements: For door hardware on doors in an accessible route, comply with governing accessibility regulations cited in “REFERENCES” article, herein.
1. Provide operating devices that do not require tight grasping, pinching, or twisting of wrist and that operate with force of not more than 5 lbf (22.2 N).
  2. Maximum opening-force requirements:
    - a. Interior, Non-Fire-Rated Hinged Doors: 5 lbf (22.2 N) applied perpendicular to door.
    - b. Sliding or Folding Doors: 5 lbf (22.2 N) applied parallel to door at latch.
    - c. Fire Doors: Minimum opening force allowable by authorities having jurisdiction.

3. Bevel raised thresholds with slope of not more than 1:2. Provide thresholds not more than 1/2 inch (13 mm) high.
  4. Adjust door closer sweep periods so that, from open position of 70 degrees, door will take at least 3 seconds to move to 3 inches (75 mm) from latch, measured to leading edge of door.
- I. Keying Conference: Conduct conference at Project site to comply with requirements in Division 01.
1. Attendees: County of Riverside, Contractor, Architect, Installer, **County of Riverside security consultant**, and Supplier's Architectural Hardware Consultant.
  2. Incorporate keying conference decisions into final keying schedule after reviewing door hardware keying system including:
    - a. Function of building, flow of traffic, purpose of each area, degree of security required, and plans for future expansion.
    - b. Preliminary key system schematic diagram.
    - c. Requirements for key control system.
    - d. Requirements for access control.
    - e. Address for delivery of keys.
    - f. .
- J. Pre-installation Conference: Conduct conference at Project site
1. Review and finalize construction schedule and verify availability of materials, Installer's personnel, equipment, and facilities needed to make progress and avoid delays.
  2. Inspect and discuss preparatory work performed by other trades.
  3. Review required testing, inspecting, and certifying procedures.
- K. Coordination Conferences:
1. Installation Coordination Conference: Prior to hardware installation, schedule and hold meeting to review questions or concerns related to proper installation and adjustment of door hardware.
    - a. Attendees: Door hardware supplier, door hardware installer, Contractor.
    - b. After meeting, provide letter of compliance to Architect, indicating when meeting was held and who was in attendance.

#### 1.6 DELIVERY, STORAGE, AND HANDLING

- A. Inventory door hardware on receipt and provide secure lock-up for hardware delivered to Project site.
- B. Tag each item or package separately with identification coordinated with final door hardware schedule, and include installation instructions, templates, and necessary fasteners with each item or package.
1. Deliver each article of hardware in manufacturer's original packaging.
- C. Project Conditions:
1. Maintain manufacturer-recommended environmental conditions throughout storage and installation periods.
  2. Provide secure lock-up for door hardware delivered to Project, but not yet installed. Control handling and installation of hardware items so that completion of Work will not be delayed by hardware losses both before and after installation.
- D. Protection and Damage:
1. Promptly replace products damaged during shipping.
  2. Handle hardware in manner to avoid damage, marring, or scratching. Correct, replace or repair products damaged during Work.

3. Protect products against malfunction due to paint, solvent, cleanser, or any chemical agent.
- E. Deliver keys to manufacturer of key control system for subsequent delivery to County of Riverside.
- F. Deliver keys **and permanent cores** to County of Riverside as directed.

#### 1.7 COORDINATION

- A. Coordinate layout and installation of floor-recessed door hardware with floor construction. Cast anchoring inserts into concrete. Concrete, reinforcement, and formwork requirements are specified in Division 03.
- B. Installation Templates: Distribute for doors, frames, and other work specified to be factory prepared. Check Shop Drawings of other work to confirm that adequate provisions are made for locating and installing door hardware to comply with indicated requirements.
- C. Security: Coordinate installation of door hardware, keying, and access control with County of Riverside's security consultant.
- D. Direct shipments not permitted, unless approved by Contractor.

#### 1.8 WARRANTY

- A. Special Warranty: Manufacturer's standard form in which manufacturer agrees to repair or replace components of door hardware that fail in materials or workmanship within specified warranty period.
  1. Warranty Period: Years from date of Substantial Completion, for durations indicated.
    - a. Closers:
      - 1) Mechanical: 30 years for LCN 1460 series and 15 years for LCN Concealed series
    - b. Exit Devices:
      - 1) Mechanical: 3 years.
    - c. Locksets:
      - 1) Mechanical: 3 years.
    - d. Continuous Hinges: Lifetime warranty
    - e. Key Blanks: Lifetime
  2. Warranty does not cover damage or faulty operation due to improper installation, improper use or abuse.

### **PART 2 - PRODUCTS**

#### 2.1 MANUFACTURERS

- A. {REMOVED}

- B. Approval of manufacturers and/or products other than those listed as "Scheduled Manufacturer" or "Acceptable Manufacturers" in the individual article for the product category shall be in accordance with QUALITY ASSURANCE article, herein.
- C. Approval of products from manufacturers indicated in "Acceptable Manufacturers" is contingent upon those products providing all functions and features and meeting all requirements of scheduled manufacturer's product.
- D. Hand of Door: Drawings show direction of slide, swing, or hand of each door leaf. Furnish each item of hardware for proper installation and operation of door movement as shown.
- E. Where specified hardware is not adaptable to finished shape or size of members requiring hardware, furnish suitable types having same operation and quality as type specified, subject to Architect's approval.

## 2.2 MATERIALS

### A. Fasteners

1. Provide hardware manufactured to conform to published templates, generally prepared for machine screw installation.
  2. Furnish screws for installation with each hardware item. Finish exposed (exposed under any condition) screws to match hardware finish, or, if exposed in surfaces of other work, to match finish of this other work including prepared for paint surfaces to receive painted finish.
  3. Provide concealed fasteners for hardware units exposed when door is closed except when no standard units of type specified are available with concealed fasteners. Do not use thru-bolts for installation where bolt head or nut on opposite face is exposed in other work unless thru-bolts are required to fasten hardware securely. Review door specification and advise Architect if thru-bolts are required.
  4. Install hardware with fasteners provided by hardware manufacturer.
- B. Provide screws, bolts, expansion shields, drop plates and other devices necessary for hardware installation.
1. Where fasteners are exposed to view: Finish to match adjacent door hardware material.

## 2.3 HINGES

### A. Provide three-knuckle, concealed bearing hinges.

#### 1. Manufacturers and Products:

- a. Scheduled Manufacturer and Product: Ives 3CB series
- b. Acceptable Manufacturers and Products: Hager AB series, McKinney TA series

### B. Requirements:

1. 1-3/4 inch (44 mm) thick doors, up to and including 36 inches (914 mm) wide:
  - a. Exterior: Standard weight, bronze or stainless steel, 4-1/2 inches (114 mm) high
  - b. Interior: Standard weight, steel, 4-1/2 inches (114 mm) high
2. 1-3/4 inch (44 mm) thick doors over 36 inches (914 mm) wide:
  - a. Exterior: Heavy weight, bronze/stainless steel, 5 inches (127 mm) high
  - b. Interior: Heavy weight, steel, 5 inches (127 mm) high
3. 2 inches or thicker doors:
  - a. Exterior: Heavy weight, bronze or stainless steel, 5 inches (127 mm) high
  - b. Interior: Heavy weight, steel, 5 inches (127 mm) high
4. Provide three hinges per door leaf for doors 90 inches (2286 mm) or less in height, and one additional hinge for each 30 inches (762 mm) of additional door height.

5. Where new hinges are specified for existing doors or existing frames, provide new hinges of identical size to hinge preparation present in existing door or existing frame.
6. Hinge Pins: Except as otherwise indicated, provide hinge pins as follows:
  - a. Steel Hinges: Steel pins
  - b. Non-Ferrous Hinges: Stainless steel pins
  - c. Out-Swinging Exterior Doors: Non-removable pins
  - d. Out-Swinging Interior Lockable Doors: Non-removable pins
  - e. Interior Non-lockable Doors: Non-rising pins
7. Width of hinges: 4-1/2 inches (114 mm) at 1-3/4 inch (44 mm) thick doors, and 5 inches (127 mm) at 2 inches (51 mm) or thicker doors. Adjust hinge width as required for door, frame, and wall conditions to allow proper degree of opening.
8. Doors 36 inches (914 mm) wide or less furnish hinges 4-1/2 inches (114 mm) high; doors greater than 36 inches (914 mm) wide furnish hinges 5 inches (127 mm) high, heavy weight or standard weight as specified.
9. Provide hinges with electrified options as scheduled in the hardware sets. Provide with sufficient number and wire gage to accommodate electric function of specified hardware. Locate electric hinge at second hinge from bottom or nearest to electrified locking component.
10. Provide mortar guard for each electrified hinge specified.
11. Provide spring hinges where specified. Provide two spring hinges and one bearing hinge per door leaf for doors 90 inches (2286 mm) or less in height. Provide one additional bearing hinge for each 30 inches (762 mm) of additional door height.

## 2.4 CONTINUOUS HINGES

### A. Aluminum Geared

1. Manufacturers:
  - a. Scheduled Manufacturer: Ives.
  - b. Acceptable Manufacturers: Markar, Stanley.
2. Requirements:
  - a. Provide aluminum geared continuous hinges conforming to ANSI/BHMA A156.25, Grade 2.
  - b. Provide aluminum geared continuous hinges, where specified in the hardware sets, fabricated from 6063-T6 aluminum, with 0.25-inch (6 mm) diameter Teflon coated stainless steel hinge pin.
  - c. Provide split nylon bearings at each hinge knuckle for quiet, smooth, self-lubricating operation.
  - d. Provide hinges capable of supporting door weights up to 450 pounds, and successfully tested for 1,500,000 cycles.
  - e. On fire-rated doors, provide aluminum geared continuous hinges that are classified for use on rated doors by testing agency acceptable to authority having jurisdiction.
  - f. Provide aluminum geared continuous hinges with electrified option scheduled in the hardware sets. Provide with sufficient number and wire gage to accommodate electric function of specified hardware.
  - g. Install hinges with fasteners supplied by manufacturer.
  - h. Provide hinges with symmetrical hole pattern.

## 2.5 FLUSH BOLTS

### A. Manufacturers:

1. Scheduled Manufacturer: Ives
2. Acceptable Manufacturers: Trimco, Rockwood

### B. Requirements:

1. Provide automatic, constant latching, and manual flush bolts with forged bronze or stainless steel face plates, extruded brass levers, and with wrought brass guides and strikes. Provide 12 inch (305 mm) steel or brass rods at doors up to 90 inches (2286 mm) in height. For doors over 90 inches (2286 mm) in height increase top rods by 6 inches (152 mm) for each additional 6 inches (152 mm) of door height. Provide dust-proof strikes at each bottom flush bolt.

## 2.6 MORTISE LOCKS

### A. Manufacturers and Products:

1. Scheduled Manufacturer and Product: Schlage L9000 series
2. Acceptable Manufacturers and Products: Best 45H series, Sargent 8200 series

### B. Requirements:

1. Provide mortise locks conforming to ANSI/BHMA A156.13 Series 1000, Grade 1 Operational, Grade 1 Security, and manufactured from heavy gauge steel, containing components of steel with a zinc dichromate plating for corrosion resistance. Provide lock case that is multi-function and field reversible for handing without opening case. Cylinders: Refer to "KEYING" article, herein.
2. Provide locks with standard 2-3/4 inches (70 mm) backset with full 3/4 inch (19 mm) throw stainless steel mechanical anti-friction latchbolt. Provide deadbolt with full 1 inch (25 mm) throw, constructed of stainless steel.
3. Provide standard ASA strikes unless extended lip strikes are necessary to protect trim.
4. Provide electrified options as scheduled in the hardware sets. Where scheduled, provide a request to exit (RX) switch that is actuated with rotation of inside lever.
5. Lever Trim: Solid brass, bronze, or stainless steel, cast or forged in design specified, with wrought roses and external lever spring cages. Provide thru-bolted levers with 2-piece spindles.
  - a. Lever Design: Schlage 17A.

## 2.7 CYLINDRICAL LOCKS – GRADE 1

### A. Manufacturers and Products:

1. Scheduled Manufacturer and Product: Schlage ND Series
2. Acceptable Manufacturers and Products: Sargent 10-Line, Best 93K Series

### B. Requirements:

1. Provide cylindrical locks conforming to ANSI/BHMA A156.2 Series 4000, Grade 1. Cylinders: Refer to "KEYING" article, herein.
2. Provide locks with standard 2-3/4 inches (70 mm) backset, unless noted otherwise, with 1/2 inch latch throw. Provide proper latch throw for UL listing at pairs.
3. Provide locksets with separate anti-rotation thru-bolts, and no exposed screws.
4. Provide independently operating levers with two external return spring cassettes mounted under roses to prevent lever sag.
5. Provide standard ASA strikes unless extended lip strikes are necessary to protect trim.
6. Provide electrified options as scheduled in the hardware sets.
7. Lever Trim: Solid cast levers without plastic inserts, and wrought roses on both sides.
  - a. Lever Design: Schlage Sparta.

## 2.8 EXIT DEVICES

### A. Manufacturer and Product:

1. Scheduled Manufacturer: Von Duprin 98/35 series
2. Acceptable Manufacturers and Products: No Substitute.

### B. Manufacturers and Products:

1. Scheduled Manufacturer: To establish standard of quality and design intent, exit device specifications have been based on Von Duprin products. Products of other manufacturers meeting or exceeding design and performance requirements specified herein will be considered for substitution subject to compliance with provisions of Division 01 Section "Product Requirements."

C. Requirements:

1. Provide exit devices tested to ANSI/BHMA A156.3-2014 Grade 1, UL certified to meet maximum 5 pound requirements according to the California Building Code section 11B-309.4, and UL listed for Panic Exit or Fire Exit Hardware. Cylinders: Refer to "KEYING" article, herein.
2. Provide touchpad type exit devices, fabricated of brass, bronze, stainless steel, or aluminum, plated to standard architectural finishes to match balance of door hardware.
3. Quiet Operation: Incorporate fluid damper or other device that eliminates noise of exit device operation.
4. Touchpad: Extend minimum of one half of door width, but not the full length of exit device rail. Provide end-cap with two-point attachment to door. Match exit device finish, stainless steel for US26, US26D, US28, US32, and US32D finishes; and for all other finishes, provide compatible finish to exit device. Provide compression springs in devices, latches, and outside trims or controls; tension springs prohibited.
5. Provide rim devices with a dual cylinder or inside thumb turn cylinder option with a visual security indicator that identifies the trims locked/unlocked status of the door from the inside of the room. Indicator in unlocked state presents a 1/2 inch x 1/2 inch white metal flag with black icon at top of device head. Indicator in locked state has no flag present. Provide rim devices without the dual cylinder or inside thumb turn cylinder option capable of being retrofitted with the visual security indicator.
6. Provide exit devices with deadlatching feature for security and for future addition of alarm kits and/or other electrical requirements.
7. Concealed Vertical Cable Exit Devices: provide cable-actuated concealed vertical latch system in two-point for non-rated or fire rated wood doors up to a 90 minute rating and less bottom latch (LBL) configuration for non-rated or fire rated wood doors up to 20 minute rating. Vertical rods not permitted.
  - a. Cable: Stainless steel with abrasive resistant coating. Conduit and core wire ends snap into latch and center slides without use of tools.
  - b. Wood Door Prep: Maximum 1 inch x 1.1875 inch x 3.875 inches top latch pocket and 1 inch x 1.1875 inch x 5 inches bottom latch pocket which does not require the use of a metal wrap or edge for non-rated or fire rated wood doors up to a 45 minute rating.
  - c. Latchbolts and Blocking Cams: Manufactured from sintered metal low carbon copper-infiltrated steel, with molybdenum disulfide low friction coating.
  - d. Top Latchbolt: Minimum 0.38 inch (10 mm) and greater than 90 degree engagement with strike to prevent door and frame separation under high static load.
  - e. Bottom Latchbolt: Minimum of 0.44 inch (11 mm) engagement with strike.
  - f. Product Cycle Life: 1,000,000 cycles.
  - g. Latch Operation: Top and bottom latch operate independently of each other. Top latch fully engages top strike even when bottom latch is compromised. Separate trigger mechanisms not permitted.
  - h. Latch release does not require separate trigger mechanism.
  - i. Cable and latching system characteristics:
    - 1) Installed independently of exit device installation, and capable of functioning on door prior to device and trim installation.
    - 2) Connected to exit device at single point in steel and aluminum doors, and two points for top and bottom latches in wood doors.



- 3) Bottom latch height adjusted, from single point for steel and aluminum doors and two points for wood doors, after system is installed and connected to exit device, while door is hanging
  - 4) Bottom latch position altered up and down minimum of 2 inches (51 mm) in steel and aluminum doors without additional adjustment. Bottom latch deadlocks in every adjustment position in wood doors.
  - 5) Top and bottom latches in steel and aluminum doors and top latch in wood doors may be removed while door is hanging.
  - 6) Top latch mounting: double or single tab mount for steel doors, face mount for aluminum doors eliminating requirement of tabs, and double tab mount for wood doors.
8. Provide exit devices with manufacturer's approved strikes.
  9. Provide exit devices cut to door width and height. Locate exit devices at height recommended by exit device manufacturer, allowable by governing building codes, and approved by Architect.
  10. Mount mechanism case flush on face of doors, or provide spacers to fill gaps behind devices. Where glass trim or molding projects off face of door, provide glass bead kits.
  11. Where lever handles are specified as outside trim for exit devices, provide heavy-duty lever trims with forged or cast escutcheon plates. Provide vandal-resistant levers that will travel to 90-degree down position when more than 35 pounds of torque are applied, and which can easily be re-set.
    - a. Lever Style: Match lever style of locksets.
  12. Provide UL labeled fire exit hardware for fire rated openings.

## 2.9 CYLINDERS: MATCH EXISTING KEY SYSTEM OR AS DIRECTED

### A. Manufacturers:

1. Scheduled Manufacturer: Schlage
2. Acceptable Manufacturers: Unknown

### B. Requirements:

1. Provide cylinders/cores, from the same manufacturer of locksets, compliant with ANSI/BHMA A156.5; latest revision, Section 12, Grade 1; permanent cylinders; cylinder face finished to match lockset, manufacturer's series as indicated. Refer to "KEYING" article, herein.
2. Provide cylinders in the below-listed configuration(s), distributed throughout the Project as indicated.
  - a. Conventional cylinder with Full Size Interchangeable Core (FSIC) core with matching existing keyway.
  - b. Keying: Manufacturer-keyed permanent cylinders/cores, configured into keying system per "KEYING" article herein.
  - c. Features: Cylinders/cores shall incorporate the following features.
3. Nickel silver bottom pins.
4. Project Cylinder/Core Distribution: Provide cylinders/cores complying with the following requirements in Project locations as indicated.
5. Replaceable Construction Cores.
  - a. Provide temporary construction cores replaceable by permanent cores, furnished in accordance with the following requirements.
    - 1) 12 construction change (day) keys.
  - b. County of Riverside's Representative will replace temporary construction cores with permanent cores.

2.10 KEYING: MATCH EXISTING KEY SYSTEM OR AS DIRECTED

- A. Provide a factory registered keying system, complying with guidelines in ANSI/BHMA A156.28, incorporating decisions made at keying conference.
- B. Requirements:
  - 1. Provide permanent cylinders/cores keyed by the manufacturer according to the following key system.
    - a. Keying system as directed by the County of Riverside.
  - 2. Forward biting list and keys separately from cylinders, by means as directed by County of Riverside. Failure to comply with forwarding requirements shall be cause for replacement of cylinders/cores involved at no additional cost to County of Riverside.
  - 3. Provide keys with the following features.
    - a. Material: Nickel silver; minimum thickness of .107-inch (2.3mm)
  - 4. Identification:
    - a. Mark permanent cylinders/cores and keys with applicable blind code per DHI publication "Keying Systems and Nomenclature" for identification. Blind code marks shall not include actual key cuts.
    - b. Identification stamping provisions must be approved by the Architect and County of Riverside.
    - c. Stamp cylinders/cores and keys with County of Riverside's unique key system facility code as established by the manufacturer; key symbol and embossed or stamped with "DO NOT DUPLICATE" along with the "PATENTED" or patent number to enforce the patent protection.
    - d. Failure to comply with stamping requirements shall be cause for replacement of keys involved at no additional cost to County of Riverside.
    - e. Forward permanent cylinders/cores to County of Riverside, separately from keys, by means as directed by County of Riverside.
  - 5. Quantity: Furnish in the following quantities.

**EDIT - Retain subparagraphs below that correspond to type of keying system retained above.**

- a. Change (Day) Keys: 3 per cylinder/core.
- b. Permanent Control Keys: 3.
- c. Master Keys: 6.
- d. Unused balance of key blanks shall be furnished to County of Riverside with the cut keys.
- e. Extra Keys:
  - 1) **<insert quantity>** Construction Keys

2.11 DOOR CLOSERS

- A. Manufacturers and Products:
  - 1. Scheduled Manufacturer and Product: LCN 1460 series
  - 2. Acceptable Manufacturers and Products: Norton 8501/8501BF series, Sargent 1331 series, Yale 3501/3501BF series
- B. Requirements:
  - 1. Provide door closers conforming to ANSI/BHMA A156.4 Grade 1 requirements by BHMA certified independent testing laboratory.
  - 2. Provide door closers with fully hydraulic, full rack and pinion action cylinder.

3. Closer Body: 1-1/4 inch (32 mm) diameter, with 5/8 inch (16 mm) diameter heat-treated pinion journal.
4. Hydraulic Fluid: Fireproof, passing requirements of UL10C, and requiring no seasonal closer adjustment for temperatures ranging from 120 degrees F to -30 degrees F.
5. Spring Power: Continuously adjustable over full range of closer sizes, and providing reduced opening force as required by accessibility codes and standards.
6. Hydraulic Regulation: By tamper-proof, non-critical valves, with separate adjustment for latch speed, general speed, and backcheck.
7. Pressure Relief Valve (PRV) Technology: not permitted.
8. Provide special templates, drop plates, mounting brackets, or adapters for arms as required for details, overhead stops, and other door hardware items interfering with closer mounting.

## 2.12 DOOR TRIM

### A. Manufacturers:

1. Scheduled Manufacturer: Ives
2. Acceptable Manufacturers: Trimco, Rockwood

### B. Requirements:

1. Provide push plates 4 inches (102 mm) wide by 16 inches (406 mm) high by 0.050 inch (1 mm) thick and beveled 4 edges. Where width of door stile prevents use of 4 inches (102 mm) wide plate, adjust width to fit.
2. Provide push bars of solid bar stock, diameter and length as scheduled. Provide push bars of sufficient length to span from center to center of each stile. Where required, mount back to back with pull.
3. Provide offset pulls of solid bar stock, diameter and length as scheduled. Where required, mount back to back with push bar.
4. Provide flush pulls as scheduled. Where required, provide back-to-back mounted model.
5. Provide pulls of solid bar stock, diameter and length as scheduled. Where required, mount back to back with push bar.
6. Provide pull plates 4 inches (102 mm) wide by 16 inches (406 mm) high by 0.050 inch (1 mm) thick, beveled 4 edges, and prepped for pull. Where width of door stile prevents use of 4 inches (102 mm) wide plate, adjust width to fit.
7. Provide wire pulls of solid bar stock, diameter and length as scheduled.
8. Provide decorative pulls as scheduled. Where required, mount back to back with pull.

## 2.13 PROTECTION PLATES

### A. Manufacturers:

1. Scheduled Manufacturer: Ives
2. Acceptable Manufacturers: Trimco, Rockwood

### B. Requirements:

1. Provide kick plates, mop plates, and armor plates minimum of 0.050 inch (1 mm) thick, beveled four edges as scheduled. Furnish with sheet metal or wood screws, finished to match plates.
2. Sizes of plates:
  - a. Kick Plates: 10 inches (254 mm) high by 2 inches (51 mm) less width of door on single doors, 1 inch (25 mm) less width of door on pairs
  - b. Mop Plates: 4 inches (102 mm) high by 2 inches (51 mm) less width of door on single doors, 1 inch (25 mm) less width of door on pairs
  - c. Armor Plates: 36 inches (914 mm) high by 2 inches (51 mm) less width of door on single doors, 1 inch (25 mm) less width of door on pairs

## 2.14 OVERHEAD STOPS AND OVERHEAD STOP/HOLDERS

### A. Manufacturers:

1. Scheduled Manufacturers: Glynn-Johnson
2. Acceptable Manufacturers: Rixson, Sargent

### B. Requirements:

1. Provide heavy duty concealed mounted overhead stop or holder as specified for exterior and interior vestibule single acting doors.
2. Provide heavy duty concealed mounted overhead stop or holder as specified for double acting doors.
3. Provide heavy or medium duty and concealed or surface mounted overhead stop or holder for interior doors as specified. Provide medium duty surface mounted overhead stop for interior doors and at any door that swings more than 140 degrees before striking wall, open against equipment, casework, sidelights, and where conditions do not allow wall stop or floor stop presents tripping hazard.
4. Where overhead holders are specified provide friction type at doors without closer and positive type at doors with closer.

## 2.15 DOOR STOPS AND HOLDERS

### A. Manufacturers:

1. Scheduled Manufacturer: Ives
2. Acceptable Manufacturers: Trimco, Rockwood

### B. Provide door stops at each door leaf:

1. Provide wall stops wherever possible. Provide convex type where mortise type locks are used and concave type where cylindrical type locks are used.
2. Where a wall stop cannot be used, provide universal floor stops for low or high rise options.
3. Where wall or floor stop cannot be used, provide medium duty surface mounted overhead stop.

## 2.16 THRESHOLDS, SEALS, DOOR SWEEPS, AUTOMATIC DOOR BOTTOMS, AND GASKETING

### A. Manufacturers:

1. Scheduled Manufacturer: Zero International
2. Acceptable Manufacturers: National Guard, Pemko

### B. Requirements:

1. Provide thresholds, weather-stripping (including door sweeps, seals, and astragals) and gasketing systems (including smoke, sound, and light) as specified and per architectural details. Match finish of other items.
2. Size of thresholds:
  - a. Saddle Thresholds: 1/2 inch (13 mm) high by jamb width by door width
  - b. Bumper Seal Thresholds: 1/2 inch (13 mm) high by 5 inches (127 mm) wide by door width
3. Provide door sweeps, seals, astragals, and auto door bottoms only of type where resilient or flexible seal strip is easily replaceable and readily available.

## 2.17 SILENCERS

### A. Manufacturers:

1. Scheduled Manufacturer: Ives
2. Acceptable Manufacturers: Trimco, Rockwood

B. Requirements:

1. Provide "push-in" type silencers for hollow metal or wood frames.
2. Provide one silencer per 30 inches (762 mm) of height on each single frame, and two for each pair frame.
3. Omit where gasketing is specified.

2.18 LATCH PROTECTORS

A. Manufacturers:

1. Scheduled Manufacturer: Ives
2. Acceptable Manufacturers: Trimco, Rockwood

B. Provide latch protectors of type required to function with specified lock.

2.19 COAT HOOKS

A. Manufacturers:

1. Scheduled Manufacturer: Ives.
2. Acceptable Manufacturers: Trimco, Rockwood

B. Provide coat hooks as specified.

2.20 FINISHES

A. Finish: BHMA 626/652 (US26D); except:

1. Hinges at Exterior Doors: BHMA 630 (US32D)
2. Continuous Hinges: BHMA 630 (US32D)
3. Push Plates, Pulls, and Push Bars: BHMA 630 (US32D)
4. Protection Plates: BHMA 630 (US32D)
5. Overhead Stops and Holders: BHMA 630 (US32D)
6. Door Closers: Powder Coat to Match
7. Wall Stops: BHMA 630 (US32D)
8. Latch Protectors: BHMA 630 (US32D)
9. Weatherstripping: Clear Anodized Aluminum
10. Thresholds: Mill Finish Aluminum

**PART 3 - EXECUTION**

3.1 EXAMINATION

- A. Prior to installation of hardware, examine doors and frames, with Installer present, for compliance with requirements for installation tolerances, labeled fire-rated door assembly construction, wall and floor construction, and other conditions affecting performance.
- B. Proceed with installation only after unsatisfactory conditions have been corrected.

3.2 INSTALLATION

- A. Mounting Heights: Mount door hardware units at heights to comply with the following, unless otherwise indicated or required to comply with governing regulations.
  1. Standard Steel Doors and Frames: ANSI/SDI A250.8.
  2. Custom Steel Doors and Frames: HMMA 831.
  3. Wood Doors: DHI WDHS.3, "Recommended Locations for Architectural Hardware for Wood Flush Doors."
- B. Install each hardware item in compliance with manufacturer's instructions and recommendations, using only fasteners provided by manufacturer.

- C. Do not install surface mounted items until finishes have been completed on substrate. Protect all installed hardware during painting.
- D. Set units level, plumb and true to line and location. Adjust and reinforce attachment substrate as necessary for proper installation and operation.
- E. Drill and countersink units that are not factory prepared for anchorage fasteners. Space fasteners and anchors according to industry standards.
- F. Install operating parts so they move freely and smoothly without binding, sticking, or excessive clearance.
- G. Hinges: Install types and in quantities indicated in door hardware schedule but not fewer than quantity recommended by manufacturer for application indicated or one hinge for every 30 inches (750 mm) of door height, whichever is more stringent, unless other equivalent means of support for door, such as spring hinges or pivots, are provided.
- H. Lock Cylinders: Install construction cores to secure building and areas during construction period.
  - 1. Replace construction cores with permanent cores as indicated in keying section.
  - 2. **. OPTION: Furnish permanent cores to County of Riverside for installation.**
- I. Key Control System: Tag keys and place them on markers and hooks in key control system cabinet, as determined by final keying schedule.
- J. Door Closers: Mount closers on room side of corridor doors, inside of exterior doors, and stair side of stairway doors from corridors. Closers shall not be visible in corridors, lobbies and other public spaces unless approved by Architect.
- K. Thresholds: Set thresholds in full bed of sealant complying with requirements specified in Division 07 Section "Joint Sealants."
- L. Stops: Provide floor stops for doors unless wall or other type stops are indicated in door hardware schedule. Do not mount floor stops where they may impede traffic or present tripping hazard.
- M. Perimeter Gasketing: Apply to head and jamb, forming seal between door and frame.
- N. Meeting Stile Gasketing: Fasten to meeting stiles, forming seal when doors are closed.
- O. Door Bottoms: Apply to bottom of door, forming seal with threshold when door is closed.

### 3.3 ADJUSTING

- A. Initial Adjustment: Adjust and check each operating item of door hardware and each door to ensure proper operation or function of every unit. Replace units that cannot be adjusted to operate as intended. Adjust door control devices to compensate for final operation of heating and ventilating equipment and to comply with referenced accessibility requirements.
  - 1. Door Closers: Adjust sweep period to comply with accessibility requirements and requirements of authorities having jurisdiction.
- B. Occupancy Adjustment: Approximately three months after date of Substantial Completion, Installer's Architectural Hardware Consultant shall examine and readjust each item of door hardware, including adjusting operating forces, as necessary to ensure function of doors, door hardware, and electrified door hardware.

### 3.4 CLEANING AND PROTECTION

- A. Clean adjacent surfaces soiled by door hardware installation.
- B. Clean operating items as necessary to restore proper function and finish.

- C. Provide final protection and maintain conditions that ensure door hardware is without damage or deterioration at time of Substantial Completion.

3.5 DEMONSTRATION

- A. Provide training for County of Riverside's maintenance personnel to adjust, operate, and maintain door hardware and door hardware finishes. Refer to Division 01 Section "Demonstration and Training."

3.6 DOOR HARDWARE SCHEDULE

- A. Locksets, exit devices, and other hardware items are referenced in the following hardware sets for series, type and function. Refer to the above-specifications for special features, options, cylinders/keying, and other requirements.
- B. Hardware Sets:

**Hardware Group 01 - Fire Riser Room (EXT)**

E106

Qty		Description	Catalog Number	Finish	Mfr
4	EA	HINGE	3CB1 4.5 X 4.5 NRP	630	IVE
1	EA	STOREROOM LOCK	LV9080T 17A	630	SCH
1	EA	FSIC CORE	23-030 OBV	626	SCH
1	EA	LOCK GUARD	LG1	630	IVE
1	EA	SURFACE CLOSER	1461 SHCUSH FC TBSRT	689	LCN
1	EA	GASKETING	188S-BK	S-Bk	ZER
1	EA	DOOR SWEEP	39A	A	ZER
1	EA	THRESHOLD	103A-226	A	ZER
1	EA	RAIN DRIP	142A	A	ZER

**Hardware Group 02 - Electric Room (Exterior)**

E105

Qty		Description	Catalog Number	Finish	Mfr
6	EA	HINGE	3CB1 4.5 X 4.5 NRP	630	IVE
1	EA	PANIC HARDWARE	9827-EO	626	VON
1	EA	PANIC HARDWARE	9827-L-NL-17	626	VON
2	EA	ROD AND LATCH GUARD	LGO-EXTENDED	US32D	VON
1	EA	RIM CYLINDER	20-057-ICX	626	SCH
1	EA	PERMANENT CORE	CONSULT RIVERSIDE COUNTY LOCKSMITH FOR SITE KEYING	626	
1	EA	FSIC CORE	23-030 OBV	626	SCH
2	EA	SURFACE CLOSER	1461 SHCUSH FC TBSRT	689	LCN
2	EA	CUSH SHOE SUPPORT	1460-30	689	LCN
	EA	GASKETING	188S-BK	S-Bk	ZER
1	EA	MEETING STILE	8193AA	AA	ZER
2	EA	DOOR SWEEP	39A	A	ZER
1	EA	THRESHOLD	103A-226	A	ZER
1	EA	RAIN DRIP	142A	A	ZER

### Hardware Group 03 - Men's Toilet Room

103

Qty		Description	Catalog Number	Finish	Mfr
4	EA	HINGE	3CB1 4.5 X 4.5	652	IVE
1	EA	CLASSROOM LOCK	ND70TD SPA	626	SCH
1	EA	PERMANENT CORE	CONSULT RIVERSIDE COUNTY LOCKSMITH FOR SITE KEYING	626	
1	EA	FSIC CORE	23-030 OBV	626	SCH
1	EA	SURFACE CLOSER	1461 FC TBSRT	689	LCN
1	EA	KICK PLATE	8400 10" X 2" LDW	630	IVE
1	EA	WALL STOP	WS406/407CVX	630	IVE
	EA	NOTE	PERIMETER SEAL BY FRAME MANUFACTURER		B/O
1	SET	ADA SIGNAGE (MEN)	SBH12M-1 X SB445	BLK	SBH

### Hardware Group 04 - Women's Toilet Room

101

Qty		Description	Catalog Number	Finish	Mfr
4	EA	HINGE	3CB1 4.5 X 4.5	652	IVE
1	EA	CLASSROOM LOCK	ND70TD SPA	626	SCH
1	EA	PERMANENT CORE	CONSULT RIVERSIDE COUNTY LOCKSMITH FOR SITE KEYING	626	
1	EA	FSIC CORE	23-030 OBV	626	SCH
1	EA	SURFACE CLOSER	1461 FC TBSRT	689	LCN
1	EA	KICK PLATE	8400 10" X 2" LDW	630	IVE
1	EA	WALL STOP	WS406/407CVX	630	IVE
	EA	NOTE	PERIMETER SEAL BY FRAME MANUFACTURER		B/O
1	SET	ADA SIGNAGE (WOMEN)	SBH12W-1 X SB443	BLK	SBH

### Hardware Group 05 - Unisex Toilet Room

107

Qty		Description	Catalog Number	Finish	Mfr
4	EA	HINGE	3CB1 4.5 X 4.5	652	IVE
1	EA	PRIVACY LOCK	ND40S SPA	626	SCH
1	EA	SURFACE CLOSER	1461 SCUSH FC TBSRT	689	LCN
1	EA	BLADE STOP SPACER	1460-61	689	LCN
1	EA	KICK PLATE	8400 10" X 2" LDW	630	IVE
	EA	NOTE	PERIMETER SEAL BY FRAME MANUFACTURER		B/O
1	SET	ADA SIGNAGE (UNISEX)	SBH12U-1 X SB444	BLK	SBH



**Hardware Group 06 - Storage/Utility Rooms (OS)**

102                      104                      110

Qty		Description	Catalog Number	Finish	Mfr
4	EA	HINGE	3CB1 4.5 X 4.5	652	IVE
1	EA	STOREROOM LOCK	ND80TD SPA	626	SCH
1	EA	PERMANENT CORE	CONSULT RIVERSIDE COUNTY LOCKSMITH FOR SITE KEYING	626	
1	EA	FSIC CORE	23-030 OBV	626	SCH
1	EA	OH STOP & HOLDER	450F	630	GLY
1	EA	KICK PLATE	8400 10" X 2" LDW	630	IVE
	EA	NOTE	PERIMETER SEAL BY FRAME MANUFACTURER		B/O

**Hardware Group 07 - Workroom Entrance**

109

Qty		Description	Catalog Number	Finish	Mfr
4	EA	HINGE	3CB1 4.5 X 4.5	652	IVE
1	EA	ENTRANCE LOCK	ND53TD SPA	626	SCH
1	EA	PERMANENT CORE	CONSULT RIVERSIDE COUNTY LOCKSMITH FOR SITE KEYING	626	
1	EA	FSIC CORE	23-030 OBV	626	SCH
1	EA	KICK PLATE	8400 10" X 2" LDW	630	IVE
1	EA	FLOOR STOP	FS439	682	IVE
1	EA	WALL STOP	WS406/407CVX	630	IVE
	EA	NOTE	PERIMETER SEAL BY FRAME MANUFACTURER		B/O

Select suitable door stop for opening configuration.

**Hardware Group 08 - Manager's Office**

113

Qty		Description	Catalog Number	Finish	Mfr
4	EA	HINGE	3CB1 4.5 X 4.5	652	IVE
1	EA	ENTRANCE LOCK	ND53TD SPA	626	SCH
1	EA	PERMANENT CORE	CONSULT RIVERSIDE COUNTY LOCKSMITH FOR SITE KEYING	626	
1	EA	FSIC CORE	23-030 OBV	626	SCH
1	EA	OH STOP & HOLDER	450F	630	GLY
	EA	NOTE	PERIMETER SEAL BY FRAME MANUFACTURER		B/O

### Hardware Group 09 - Lounge

108

Qty		Description	Catalog Number	Finish	Mfr
4	EA	HINGE	3CB1 4.5 X 4.5	652	IVE
1	EA	PASSAGE SET	ND10S SPA	626	SCH
1	EA	FLOOR STOP	FS439	682	IVE
1	EA	WALL STOP	WS406/407CVX	630	IVE
	EA	NOTE	PERIMETER SEAL BY FRAME MANUFACTURER		B/O

Select suitable door stop for opening configuration.

### Hardware Group 10 - Storeroom (Pairs)

114

Qty		Description	Catalog Number	Finish	Mfr
8	EA	HINGE	3CB1 4.5 X 4.5	652	IVE
1	EA	CONST LATCHING BOLT	FB51T 24"	630	IVE
1	EA	STOREROOM LOCK	ND80TD SPA	626	SCH
1	EA	PERMANENT CORE	CONSULT RIVERSIDE COUNTY LOCKSMITH FOR SITE KEYING	626	
1	EA	FSIC CORE	23-030 OBV	626	SCH
2	EA	KICK PLATE	8400 10" X 2" LDW	630	IVE
2	EA	WALL STOP	WS406/407CVX	630	IVE
1	EA	MEETING STILE	41AA	AA	ZER
	EA	NOTE	PERIMETER SEAL BY FRAME MANUFACTURER		B/O

### Hardware Group GD-01 - Public Meeting Room

115A

115B

Qty		Description	Catalog Number	Finish	Mfr
2	EA	DA SPRING HINGE	31M8010SA	630	CRL
1	SET	LONG DOOR PULL	PR 9266F 36" 20" P	630	IVE

**Hardware Group SF-01 - Library Entrance**

E100

Qty		Description	Catalog Number	Finish	Mfr
2	EA	CONT. HINGE	224HD	628	IVE
1	EA	PANIC HARDWARE	CDSI-3549A-EO	626	VON
1	EA	PANIC HARDWARE	CDSI-3549A-T-360T	626	VON
1	EA	MORTISE CYLINDER	20-061-ICX	626	SCH
2	EA	MORTISE CYLINDER	26-091 XQ11-948 OBV	626	SCH
3	EA	PERMANENT CORE	CONSULT RIVERSIDE COUNTY LOCKSMITH FOR SITE KEYING	626	
1	EA	FSIC CORE	23-030 OBV	626	SCH
2	EA	LONG DOOR PULL	9264F 36" 20" STD	630	IVE
2	EA	CONCEALED CLOSER	2031 BUMP WMS	689	LCN
1	EA	PERIMETER SEALS BY	DOOR/FRAME MANUFACTURER	GRY	B/O
2	EA	DOOR SWEEP	381A	A	ZER
2	EA	DOOR SWEEP	39A	A	ZER
1	EA	THRESHOLD	103A-226	A	ZER

**\*\*\*END OF SECTION\*\*\***

**THIS PAGE IS INTENTIONALLY BLANK**

## SECTION 08 80 00

### GLAZING

#### **PART 1 -- GENERAL**

##### 1.01 SUMMARY

Division 0, Contract Requirements and Division 1, General Conditions apply to this Section.

##### 1.02 SCOPE OF WORK

All of the requirements of the Contract Documents apply to this Section.

##### 1.03 REFERENCES

- A. SIGMA No. 64-7-2 -- Specification for Sealed Insulating Glass Units.
- B. FGMA -- Glazing Manual, Glazing Sealing Systems Manual.

##### 1.04 QUALITY ASSURANCE

Conform to Flat Glass Marketing Association (FGMA) for glazing installation methods.

##### 1.05 SUBSTITUTIONS

Substitutions will be considered per the Instructions to Bidders, Section 3.3 Substitutions.

##### 1.06 SUBMITTALS

- A. Provide in accordance with Article 3.11 of the General Conditions.
- B. Provide structural, physical and environmental characteristics, size limitations, and special handling or installation requirements.
- C. Provide data on glazing sealant. Identify colors available.
- D. Submit two samples, illustrating glass unit and coloration.

##### 1.07 EXTENDED WARRANTY

- A. Contractor shall guarantee the work covered by this specification against all defects in material and workmanship for a period of not less than FIVE (5) years.
- B. Include coverage of sealed glass units from seal failure, interpane dusting or misting, and replacement.

#### **PART 2 -- PRODUCTS**

##### 2.01 ACCEPTABLE GLASS MANUFACTURERS

- A. Insulated, Laminated, and Spandrel Glass: PPG Industries, Inc.
- B. Security Glazing: Nippon Electric Glass Company (800) 426-0279.
- C. Clear Fire-Rated Window Glazing: Pyrobel by Interedge (877) 376-3343.
- D. Clear Fire-Rated Door/Sidelight Glazing: PyroEdge or Pyrobel by Interedge (877) 376-3343.

##### 2.02 GLASS MATERIALS (As indicated on the Window Schedule):

- A. General: Exposed "tong" marks are not acceptable.
- B. Interior Tempered Glass: Clear, Tempered ¼" thick. Grade B (tempered), Style I (uncoated), Type I (float or plate).

C. Insulated Glass Units:

1. Double pane 1/4" units with edge seal; interpane 1/2" space purged with dry hermetic air; total unit thickness of 1 inch.
2. Tempered as required by Code and indicated on drawings.
3. Performance values based on tinted product selected.
4. Tinting as indicated on Window Schedule - tinted on inside of outer layer only. PPG Solarban 70XL.
5. Coating: low e coating. On inside of outer layer – surface two (2).

D. Interior Wired Glass: 1/4" clear wire glass.

E. Security Glazing: 11/16" thick, glazing assembly consisting of two outer lights of 1/8" clear chemically strengthened glass with a core of two 1/8" polycarbonate sheets laminated with four inter-layers of .50 inch thick urethane.

F. Clear Fire Glazing: Model as required for required Fire-Rated Assembly.

2.03 GLAZING COMPOUNDS

A. Glazing Compound: Modified oil type, non-hardening, knife grade consistency.

B. Butyl Sealant: Single component; Shore-A hardness of 10-20; black color; non-skinning.

C. Acrylic Sealant: Single component, solvent curing, cured Shore hardness, non-bleeding.

D. Silicone Sealant: Single component, non-bleeding, non-staining; Capable of water immersion without loss of properties.

2.04 GLAZING ACCESSORIES

A. Setting Blocks: Neoprene; 80-90 Shore A durometer hardness; 4 inch minimum long x 1/4 inch thick.

B. Spacer Shims: Neoprene; 40-50 Shore A durometer hardness; 4 inch long on 18 inch centers for wet-glazed systems.

C. Glazing Clips: Manufacturer's standard type.

**PART 3 -- EXECUTION**

3.01 EXAMINATION

A. Examine the area and conditions under which work of this Section will be performed.

B. Coordinate work with other trades as needed to assure that proper substrate are provided to receive work of this Section.

C. Verify surfaces of glazing channels or recesses are clean, square in plane, free of obstructions, and ready for work of this Section.

D. Verify weep holes in exterior frame are provided.

E. Correct conditions detrimental to timely and proper completion of the Work.

F. Do not proceed until unsatisfactory conditions are corrected.

G. Beginning of installation means acceptance of conditions.

3.02 PREPARATION

A. Clean contact surfaces with solvent and wipe dry.

B. Seal porous glazing channels or recesses.

3.03 EXTERIOR WET METHOD (SEALANT AND SEALANT)

- A. Place setting blocks at 1/4 points and install glass pane.
- B. Install removable stops with pane centered in space by inserting spacer shims both sides at 18-inch intervals, 1/4 inch below sightline.
- C. Fill gap between pane and stops with sealant to depth equal to bite of frame on pane, but not more than 3/8 inch below sightline.
- D. Apply sealant to uniform line, flush with sightline. Tool or wipe sealant surface with solvent for smooth appearance. Security Glazing to be sealed with security sealant as recommended by manufacturer.
- E. Drain or weep the sill of each opening to the outdoors at three points using 3/8-inch diameter weep holes or the equivalent.

3.04 INTERIOR COMBINATION METHOD (TAPE AND SEALANT)

- A. Cut glazing tape to length and install against permanent stops, project 1/16 inch above sightline.
- B. Place setting blocks at 1/4 points.
- C. Rest glass on setting blocks and push against tape to ensure full contact at perimeter of pane.
- D. Install: removable stops, spacer shims between glass, and applied stops at 18-inch intervals 1/4 inch below sightline.
- E. Fill gap between pane and applied stop with sealant to depth equal to bite of frame on pane to uniform and level line.
- F. Trim protruding tape edge.

3.05 INTERIOR WET METHOD (COMPOUND AND COMPOUND)

- A. Install glass resting on setting blocks. Install applied stop and center pane by use of spacer shims at 18-inch centers, kept 1/4 inch below sightline.
- B. Locate and secure glass pane using glaziers' clips.
- C. Fill gaps between pane and stops with glazing compound until flush with sightline.

3.06 CLEANING

- A. After installation, mark pane with an "X" by using plastic tape or removable paste.
- B. Remove glazing materials from finish surfaces.
- C. Remove labels after work is completed.
- D. Clean glass with solvent and normal wash. Final cleaning and polishing shall be done prior to final inspection.
- E. Remove and replace broken, scratched, chipped or otherwise defective glass with new materials and leave the entire installation in a neat, clean, and acceptable condition.

**\*\*\* END OF SECTION \*\*\***

**THIS PAGE IS INTENTIONALLY BLANK**



## SECTION 09 20 00

### LATH AND PLASTER

#### **PART 1 -- GENERAL**

##### 1.01 GENERAL REQUIREMENTS

Division 0, Contract Requirements and Division 1, General Requirements apply to this Section

##### 1.02 SCOPE OF WORK

Supply and install all Lath and Plaster Work as shown on the Drawings and as specified herein, for a complete and proper installation.

##### 1.03 REFERENCE STANDARDS

Comply with all applicable requirements of the California Lathing and Plastering Contractor's Association "Reference Specifications" except where more stringent requirements are indicated herein or in local building codes.

##### 1.04 SUBMITTALS

- A. Submit Product Data and color samples and manufacturers application data.
- B. Make (2) samples, at least one-foot square, of selected specified plaster system.

##### 1.05 QUALITY ASSURANCE

- A. In all Work under this Section, coordinate with all other trades whose work connects with, is affected or concealed by lathing and plastering. Before proceeding, make certain all required inspections have been made. Do all cutting and patching required to accommodate the work of other trades.
- B. Inspect surfaces to receive lath and plaster before starting Work and do not start until surfaces are acceptable. Starting Work under this Section implies acceptance of surfaces.

##### 1.06 SUBSTITUTIONS

Substitutions will be considered per the Instructions to Bidders, Section 3.3 Substitutions.

##### 1.07 PRODUCT HANDLING

Deliver all manufactured materials in original packages bearing manufacturer's name and brand. Use only one brand of each material throughout job. Store materials in dry areas.

#### **PART 2 -- PRODUCTS**

##### 2.01 LATH

Paperbacked Lath: K-Lath Corporation: "Aqua K-Lath", or as approved by Architect, 16 gauge wires spaced 1-1/2 inches o.c. vertically and welded to 16 gauge wires spaced 2 inches o.c. horizontally, with perforated Kraft paper to insure plaster embedment and Type I Class B waterproof building paper laminated to back side.

##### 2.02 ACCESSORIES

- A. Corner Bead: #1X Type, Keene or equal, expanded metal flanges integral with nose bead of solid metal, galvanized.
- B. Corner Lath: As specified for expanded metal, three (3) inch legs bent to a 105-degree corner, - "Cornemaster #30" by Keene, or equal.

- C. Casing Beads: #66 Type, Western, or equal, expanded metal flange, galvanized, depth as required by plaster thickness, weighing approximately 200# per 1000 lineal feet for 3/4-inch and 7/8-inch types.
- D. Expansion Joints: #15 by Keene or equal. Cut lath passing under expansion joints. Install where indicated on Drawings, with the following minimum conditions:
  - 1. No length should be greater than 18 feet in either direction
  - 2. No panel shall exceed a maximum of 144 square-feet for vertical applications.
  - 3. No panel shall exceed a maximum of 100 square-feet for horizontal, curved or angular sections.
  - 4. No length-to-width ratio should exceed 2.5 to 1 in any given panel.
- E. Bonding Agent: As recommended for application over smooth monolithic concrete shells. Concrete shells shall be cleaned with bonding agent applied prior to plastering interior.
- F. Wire: Soft, annealed, galvanized steel, 8-gauge for hangers, 16-gauge for channel ties and 18-gauge for lath ties.
- G. Nails: Concrete nails, case hardened steel, 3/4 inch long.
- H. Weep Screed: by Keene or equal. 1-1/4" ground, galvanized.
- I. Building Paper: 15#, asphalt impregnated. Install over Weather Barrier specified in Section 07250 and shown on the Drawings.
- J. Miscellaneous Items: Furnish all miscellaneous components not specified herein but shown on the Drawings and any other items required to complete the installation.
- K. Water: Clean and free of deleterious matter.

### 2.03 PORTLAND CEMENT PLASTER

- A. Portland Cement: Conforming to ASTM C-150, Type 1.
- B. Sand for Cement Plaster: Conforming to ASA A42.2.
- C. Hydrated Lime: Conforming to ASTM C-206, Type S.
- D. Quick Lime: Conforming to ASTM C-5.
- E. Exterior Cement Plaster:
  - 1. Scratch Coat: One part Portland Cement, four (4) parts sand and hydrated lime equal to 25% volume of cement.
  - 2. Brown Coat: One part Portland Cement, five parts sand and hydrated lime equal to 25% of the volume of cement.
  - 3. Finish Coat: Portland Cement-Lime: one part standard Portland Cement, not more than 1/2 part dry hydrated lime (or an equivalent amount of lime putty) and not more than one part #20 mesh, and one part #16 mesh silica sand. Submit finish sample(s) for Architect's approval.
  - 4. Thickness: 7/8 inch thick, measured from back of lath.
  - 5. Finish coat to contain integral color. Submit samples to Architect for approval based upon colors indicated on Drawings.

## **PART 3 -- EXECUTION**

### 3.01 EXAMINATION

- A. Examine the areas and condition under which work of this Section will be performed.

- B. Verify that specified items may be installed in accordance with the approved design.
- C. Correct conditions detrimental to timely and proper completion of the Work.
- D. Do not proceed until unsatisfactory conditions are corrected.
- E. Beginning of installation means acceptance of conditions.

### 3.02 GENERAL

- A. Coordinate work with other trades as needed to assure that proper substrate are provided to receive work of this Section.
- B. Provide ventilation to properly dry plaster during and subsequent to application. In glazed areas, accomplish by keeping windows open sufficiently to provide air circulation; in enclosed areas lacking normal ventilation, mechanically remove moisture-laden air.

### 3.03 LATHING

- A. Apply lath with long dimension at right angles to supports; lap side and ends as recommended by manufacturer. Stagger vertical laps. Make no vertical joints at any corner; bend lath around all corners, internal and external.
- B. Attach lath to studs by fasteners at spacings required by local building codes. All attachments to be corrosion resistant.
- C. Install all accessories to plumb, true and level lines, and backing plates as located by the trade furnishing these items.
- D. Install beads, corner laths, control joints, reglets, screeds, and like items, using single lengths wherever possible. Provide corner beads at all exterior corners shown, mitering or coping as required, and fastening at six (6) inches o.c., both sides. Provide casing beads wherever interior plaster angles are shown and wherever one or both abutting surfaces are metal lathed, except corner laths are not required where metal lath is continuous around corner at junctions of walls, or where ceiling lath turns down a wall. Tie outer edges only to adjoining lath at six (6) inches o.c. or stub nail to any concrete. Install access panels supplied by other trades.
- E. Start installation at bottom of wall, working up and from right to left. Apply lath with long dimension at right angles to supports; lap sides and ends as recommended by manufacturer. Stagger vertical laps. Make no vertical joints at any corner; bend lath around all corners, internal and external.
- F. Attach lath to metal and/or wood studs by means of tie wire and nails respectively at spacings as required by Local Building Codes. All attachments shall be corrosion resistant.
- G. Install corner beads at all external corners. Use single length except where standard length is not sufficient. Miter or cope as required; fasten with tie wire at six (6) inches o.c., both sides.
- H. Install at interior angles and sheer one or both abutting surfaces are metal lath. Corner laths are not required where metal lath is continued around corner at junction of walls and where ceiling lath turns down wall unless otherwise noted on drawings. The outer edges only to adjoining lath at six (6) inches o.c., or stub nail to concrete.

### 3.04 PLASTERING

- A. Do not apply plaster below 55 degrees F temperature. Apply no plaster to frosty surfaces. Dampen any surfaces on which suction must be reduced with fog-spray. Maintain all screeds plumb and true.
- B. Except when hand mixing small batches is approved, use approved mechanical mixers. Clean mixers, mixing boxes and tools after mixing each batch. Thoroughly mix with water until

uniform in color and consistency. Retempering not permitted. Discard plaster, which has begun to stiffen. Mix in strict accordance with manufacturer's printed directions.

- C. Except in the case of specifically formulated plasters, which require only water added job site, proportion by volume as specified.
- D. Scratch coat: Apply with sufficient material and pressure to shove material through metal lath and form a good key; 3/8 inch minimum thickness, score in horizontal direction with metal scorer with clipped teeth to provide good mechanical key for second coat. Dampen concrete and concrete block surfaces to reduce suction prior to application.
- E. Brown coat: Apply not sooner than 48 hours after application of scratch coat; properly dampen scratch coat; apply sufficient pressure to force plaster into scratches and build out to within 1/8 inch to screeds; for, float and darby to true, plumb surfaces and corners; leave rough for finish coat.
- F. Curing: Keep Brown coat moist for at least 48 hours; commence moistening as soon as plaster has hardened sufficiently so to prevent injury; apply water in a fine fog spray; avoid soaking; curing shall proceed over holidays, Saturdays and Sundays if necessary. If atmospheric conditions are hot and dry, curing time shall be extended as necessary at no additional cost to Owner. Allow plaster base coats to cure for a minimum of fourteen (14) days before applying finish coat.
- G. Finish coats Apply to partially dry base coat, or to a thoroughly dry base coat that has been evenly wetted by brushing or spraying; avoid use of excessive water. Trowel all finish surfaces of plaster to perfectly true and even surface without scratches, ridges, voids, cracks, etc. Fill fissures or breaks in brown coat and existing plaster before application of finish coat. Make coats uniform in thickness with average thickness about 1/8 inch; minimum thickness anywhere: 1/16 inch.

### 3.05 CLEANING AND PATCHING

- A. A clean floor of droppings immediately after each coat is applied. At any exterior locations, remove droppings or splashes from all concrete, masonry or other finish surfaces.
- B. Patch after all other Work, except painting, has been completed. Cut out damaged or broken plaster to straight lines with clean, sharp edges. Cut out cracks to width of at least one (1) inch. Fill areas to be patched with base materials, and then give a finish coat of same material as adjoining plaster. Patched areas shall match adjoining work in finish and texture. Joining shall be flush and smooth so joints between patch and existing plaster are not noticeable.
- C. At completion of Work, remove excess plaster from beads, screeds, etc., and leave Work clean and ready for painting. Promptly remove plaster, rubbish, surplus material, scaffolding and other equipment from job site. Leave areas broom clean.

**\*\*\* END OF SECTION \*\*\***

## SECTION 09 21 16

### GYPSUM BOARD SYSTEMS

#### **PART 1 - GENERAL**

##### 1.01 GENERAL REQUIREMENTS

Division 0, Contract Requirements and Division 1, General Requirements apply to this Section.

##### 1.02 SECTION INCLUDES

- A. Fire-Resistance Rated Gypsum Board
- B. Mold and Moisture Resistant Gypsum Board
- C. Fire-Resistance, Mold and Moisture Resistant Gypsum Board
- D. Abuse Resistant Gypsum Board
- E. Impact Resistant Gypsum Board
- F. Cement Board

##### 1.03 SUBSTITUTIONS

Substitutions will be considered per the Instructions to Bidders, Section 3.3 Substitutions.

##### 1.04 SUBMITTALS

Provide in accordance with Article 3 of the General Conditions.

##### 1.05 PERFORMANCE CRITERIA

- A. Abuse Resistant Gypsum Board
  - 1. Classification:
    - a. Surface Abrasion: Level 1-3
    - b. Surface Indention: Level 1
    - c. Soft Body Impact: Level 1-2
  - 2. Wall Assembly Fire-Resistance Rating: locations per the drawings.

#### **PART 2 - PRODUCTS**

##### 2.01 MANUFACTURER / PRODUCTS

Basis of Design: Products of National Gypsum Company

##### 2.02 FIRE-RESISTANCE RATED GYPSUM BOARD

- A. Basis of Design: Gold Bond® BRAND Fire-Shield C Gypsum Board.
- B. Panel Physical Characteristics:
  - 1. Core: Enhanced fire-resistance rated gypsum core
  - 2. Surface paper: 100% recycled content paper on front, back and long edges
  - 3. Long Edges: [Square] or [Tapered] at Contractor's discretion.
  - 4. Overall thickness: 5/8 inch.
  - 5. Panel complies with Type X requirements of ASTM C 1396 Standard Specification for Gypsum Board

2.03 MOLD AND MOISTURE RESISTANT GYPSUM BOARD

A. Basis of Design: Gold Bond® BRAND XP® Gypsum Board

B. Panel Physical Characteristics

1. Core: Mold and moisture resistant gypsum core.
2. Surface paper: 100% recycled content moisture/mold/mildew resistant paper on front, back, and long edges.
3. Long Edges: Square or Tapered at Contractor's discretion.
4. Overall thickness: 5/8 inch.
5. Panel complies with requirements of ASTM C 1396 Standard Specification for Gypsum Board.
6. Mold/Mildew Resistance: 10 when tested in accordance with ASTM D 3273 Standard Test Method for Resistance to Growth of Mold on the Surface of Interior Coatings in an Environmental Chamber

2.04 FIRE-RESISTANCE RATED GYPSUM BOARD WITH ENHANCED MOLD AND MILDEW RESISTANCE

A. Basis of Design: Gold Bond® BRAND XP® Fire-Shield® C Gypsum Board

B. Type C, Panel Physical Characteristics

1. Core: Mold and moisture resistant, with enhanced fire-resistance rated gypsum core
2. Surface paper: 100% recycled content moisture/mold/mildew paper on front, back and long edges
3. Long Edges: Square or Tapered at Contractor's discretion.
4. Overall thickness: 5/8 inch.
5. Panel complies with requirements Type X of ASTM C 1396 Standard Specification for Gypsum Board
6. Mold/Mildew Resistance: 10 when tested in accordance with ASTM D 3273 Standard Test Method for Resistance to Growth of Mold on the Surface of Interior Coatings in an Environmental Chamber

2.05 ABUSE RESISTANT GYPSUM BOARD

A. Basis of Design: Gold Bond® BRAND Hi-Abuse® XP® Gypsum Board

B. Panel Physical Characteristics

1. Core: Fire resistance rated gypsum core, with additives to enhance, surface indentation resistance and impact resistance.
2. Surface paper: Abrasion resistant, 100% recycled content moisture/mold/mildew resistant paper on front, back and long edges
3. Long Edges: Square or Tapered at Contractor's discretion.
4. Overall thickness: 5/8 inch.
5. Panel complies with Type X requirements ASTM C 1396 Standard Specification for Gypsum Board.
6. Surface Abrasion Resistance: 0.009 inch when tested in accordance with ASTM D 4977 Standard Test Method for Granule Adhesion to Mineral Surfaced Roofing by Abrasion

7. Indentation Resistance: 0.132 inch when tested in accordance with ASTM D 5420 Standard Test Method for Impact Resistance of Flat, Rigid Plastic Specimen by Means of a Striker Impacted by a Falling Weight (Gardner Impact)
8. Soft Body Impact: 210 ft-lbf when tested in accordance with ASTM E 695 Standard Method for Measuring Relative Resistance of Wall, Floor, and Roof Construction to Impact Loading
9. Mold/Mildew Resistance: score of 10 when tested in accordance with ASTM D 3273 Standard Test Method for Resistance to Growth of Mold on the Surface of Interior Coatings in an Environmental Chamber

## 2.06 CEMENT BOARD

### A. Cement Backerboard

1. Basis of Design: PermaBase® BRAND Cement Board
2. Panel Physical Characteristics
  - a. Core: Cementitious, water-durable
  - b. Surface: Fiberglass mesh on front and back
  - c. Long Edges: Tapered
  - d. Overall Thickness: 5/8 inch.
  - e. Panel complies with requirements of ASTM C 1325 Standard Specification for Non-Asbestos Fiber-Mat Reinforced Cementitious Backer Units and ANSI A118.9
  - f. Density: 72 lbs. per cu. ft.
  - g. Water Absorption: Not greater than 8% when tested for 24 hours in accordance with ASTM C 473 Standard Test Methods for Physical Testing of Gypsum Panel Products

### B. Cement Board Underlayment

1. Basis of Design: PermaBase® BRAND Cement Board
2. Panel Physical Characteristics
  - a. Core: Cementitious, water-durable
  - b. Surface: Fiberglass mesh on front and back
  - c. Long Edges: Tapered
  - d. Overall Thickness: 1/4 inch
  - e. Panel complies with requirements of ASTM C 1325 and ANSI A118.9
  - f. Density: 72 lbs per cu. ft.
  - g. Water Absorption: Not greater than 8% when tested for 24 hours in accordance with ASTM C 473 Standard Test Methods for Physical Testing of Gypsum Panel Products

## 2.07 ACCESSORY PRODUCTS

### A. Acoustical sealant

1. Conform to ASTM C 919 Standard Practice for Use of Sealants in Acoustical Applications
2. Products/Manufacturer

- a. Grabber Acoustical Sealant GSC
  - b. STI SpecSeal Smoke N Sound Caulk
  - c. BOSS 824 Acoustical Sound Sealant
- B. Firestopping
- 1. Conform to ASTM E 90 Standard Test Method for Laboratory Measurement of Airborne Sound Transmission Loss of Building Partitions and Elements
  - 2. Products/Manufacturer
    - a. STI SpecSeal SSP Putty Pads
    - b. BOSS 818 Fire Rated Putty Pads
- C. Fasteners for use with 5/8 inch thick tile backer panels: As recommended by Manufacturer.
- D. Fasteners for use with Cement Board:
- 1. PermaBase Cement Board Hi-Lo thread screws (No. 8).
  - 2. Wafer head, corrosion-resistant.
  - 3. Overall Thickness: As recommended by Manufacturer.
  - 4. For use with wood framing and complying with ASTM C 1002 Standard Specification for Steel Self-Piercing Tapping Screws for the Application of Gypsum Panel Products or Metal Plaster Bases to Wood Studs or Steel Studs.
- E. Joint Treatment
- 1. Tape - As recommended by Manufacturer:
    - a. Paper Tape: 2-1/16 inches wide.
    - b. Paper Tape: 2 inches wide with metal strips laminated along the center crease to form inside and outside corners.
    - c. Fiberglass Tape: Nominal 2 inches wide self-adhering tape.
    - d. Alkali-resistant Fiberglass Tape: Nominal 2 inches wide polymer coated alkali-resistant mesh tape.
  - 2. Drying Type Compound - As recommended by Manufacturer:
    - a. Ready Mix vinyl base compound.
    - b. Ready Mix vinyl base compound formulated for enhanced mold and mildew resistance.
    - c. Ready Mix vinyl base compound formulated to reduce airborne dust during sanding.
    - d. Ready Mix vinyl base topping compound for finish coating.
    - e. Ready Mix vinyl base compound for embedding joint tape, corner beads or other accessories.
    - f. Field Mix vinyl base compound.
  - 3. Setting Compound - As recommended by Manufacturer:
    - a. Field mixed hardening compound.
    - b. Field mixed hardening compound for fire resistance rated construction and penetrations.



4. Joint Sealant: Conform to ASTM C920 Standard Specification for Elastomeric Joint Sealants.
5. Finish Level: Provide a Level 4 Finish, with a light orange-peel texture. All joints and interior angles shall have tape embedded in joint compound and two separate coats of joint compound applied over all flat joints and one separate coat of joint compound applied over interior angles. Fastener heads and accessories shall be covered with three separate coats of joint compound. All joint compounds shall be smooth and free from tool marks and ridges. The prepared surface shall be coated with Sheet Rock Brand First Coat Primer, or equal, prior to the application of the light orange-peel texture.

### **PART 3 - EXECUTION**

#### **3.01 EXAMINATION**

- A. Examine areas to receive gypsum products to verify conditions.
- B. Report conditions contrary to contract requirements that would prevent a proper installation.
- C. Do not proceed with the installation until unsatisfactory conditions have been corrected.
- D. Failure to call attention to defects or imperfections will be construed as acceptance and approval of the conditions.
- E. Installation indicates acceptance of the conditions with regard to conditions existing at the time of installation.

#### **3.02 INSTALLATION, ABUSE RESISTANT GYPSUM BOARD**

Install in accordance with manufacturer recommendations

#### **3.03 INSTALLATION, CEMENT BOARD**

Install in accordance w/manufacturer recommendation and ANSI A108.11

#### **3.04 INSTALLATION, TILE BACKER**

##### **A. General:**

1. Install in accordance with manufacturer recommendations, ASTM C840 and GA-216
2. Install with acrylic coated water barrier side facing away from the framing, so that finishes shall be applied to the coated side.
3. Caulk or seal penetrations and abutments to dissimilar materials.

##### **B. Tile Backer Installation for walls:**

1. Install panels horizontal or vertical to supports spaced a maximum of 16 inches on center without blocking or 24 inches on center with blocking at all joints for ½ inch thick panels and 24 inches on center for 5/8" inch thick panels.
2. Space fasteners 8 inches on center along all support members. Drive fasteners flush with the panel surface, do not countersink.
3. Dry Non-Tile Applications
  - a. Tape joints with fiberglass mesh tape and embed with setting type joint compound.
  - b. Skim the surface with a setting or ready-mix joint compound.

4. Wet Non-Tile Applications

- a. Finish walls with a direct applied finish systems, or materials suitable for humid environments.
- b. Seal transitions and abutments to dissimilar materials with flexible joint sealant.

**\*\*\*END OF SECTION\*\*\***

## SECTION 09 30 00

### TILEWORK

#### **PART 1 -- GENERAL**

##### 1.01 GENERAL REQUIREMENTS

- A. Division 0, Contract Requirements and Division 1, General Requirements apply to this Section.
- B. Furnish materials and equipment and perform labor required to complete all Ceramic Tile work as indicated on the drawings, specified herein, and necessary to complete the work of this section.

##### 1.02 SECTION INCLUDES

- A. Porcelain.
- B. Floor and Wall Glazed.
- C. Wall and Counter Glazed.
- D. Trim and Accessories.
- E. Setting Materials.

##### 1.03 STANDARDS

- A. Comply with TCNA's "Handbook for Ceramic Tile Installation" for TCNA installation methods specified in tile installation schedules. Comply with parts of the ANSI A108 Series "Specifications for Installation of Ceramic Tile" that are referenced in TCNA installation methods, specified in tile installation schedules, and apply to types of setting and grouting materials used.
- B. Certificate of grade: Submit for approval, with each delivery, manufacturer's grade certificate in conformance with Tile Manufacturers Association, certifying grade, type and quality of tile furnished.
- C. Dynamic Coefficient of Friction: For tile installed on walkway surfaces, provide products with the following values as determined by testing identical products per ANSI 137.1.
- D. Tile delivered in sealed cartons identified with grade certificate.
- E. Cartons of tile kept dry until tiles are removed, tile prevent from staining.
- F. All tile free from chips, cracks, scratches, pits or other defects.

##### 1.04 PERFORMANCE REQUIREMENTS

Static Coefficient of Friction: Tile on walkway surfaces shall be provided with the following values as determined by testing in conformance with ASTM C 1028.

- 1. Level Surfaces: Minimum of 0.6 (Wet).
- 2. Step Treads: Minimum of 0.6 (Wet).
- 3. Ramp Surfaces: Minimum of 0.8 (Wet).

##### 1.05 QUALITY ASSURANCE

- A. Manufacturer Qualifications: Company specializing in manufacturing the products of this section with minimum ten years documented experience.
- B. Installer Qualifications: Company specializing in performing the work of this section with minimum of five years' documented experience.
- C. Single Source Responsibility: Obtain each type and color of tile from a single source. Obtain

each type and color of mortar, adhesive and grout from the same source.

#### 1.06 SUBMITTALS

- A. Product Data: Manufacturer's data sheets on each product to be used, including:
  - 1. Manufacturer's Specifications, catalog cuts, and other data needed to prove compliance with the specified requirements of tile, sealants, grout, trim, fasteners, adhesives and sealers.
  - 2. Preparation instructions and recommendations.
  - 3. Storage and handling requirements and recommendations.
  - 4. Installation methods.
- B. Shop Drawings: Indicate tile layout, patterns, color arrangement, perimeter conditions, junctions with dissimilar materials, control and expansion joints, thresholds, ceramic accessories, and setting details.
- C. Selection Samples: Samples of actual tiles for selection.
- D. Samples: Mount tile and apply grout on two plywood panels, illustrating pattern, color variations, and grout joint size variations.
- E. Manufacturer's Certificate:
  - 1. Certify that products meet or exceed specified requirements.
  - 2. For each shipment, type and composition of tile provide a Master Grade Certificate signed by the manufacturer and the installer certifying that products meet or exceed the specified requirements of ANSI A137.1.
- F. Results of compliance of Flooring Substrate for requirements of Moisture & PH Testing prior to installation – See Item 3.01.E & F.
- G. Mock-Up: Provide a mock-up for evaluation of surface preparation techniques and application workmanship.
  - 1. Locate mock-ups on site in locations and size directed by Architect.
  - 2. Finish areas designated by Architect.
  - 3. Do not proceed with remaining work until workmanship, color, and sheen are approved by Architect.
  - 4. Refinish mock-up area as required to produce acceptable work.
  - 5. Retain and maintain mock-ups during construction in undisturbed condition as a standard for judging completed unit of Work.
  - 6. Obtain Architect's acceptance of mock-ups before start of final unit of Work.

#### 1.07 PRODUCT HANDLING

- A. Deliver and store packaged materials in original containers with seals unbroken and labels intact until time of use. Comply with requirements of ANSI A137.1 for labeling sealed tile packages.
- B. Prevent damage or contamination to materials by water, freezing, foreign matter and other causes.
- C. Store and dispose of solvent-based materials, and materials used with solvent-based materials, in accordance with requirements of local authorities having jurisdiction

## 1.08 ENVIRONMENTAL REQUIREMENTS

- A. Maintain environmental conditions (temperature, humidity, and ventilation) within limits recommended by manufacturer for optimum results. Do not install products under environmental conditions outside manufacturer's absolute limits.
- B. Environmental: Install mortar, set and grout tile when surfaces and ambient temperature is minimum 50 degrees F (10 degrees C) and maximum 90 degrees F (32 degrees C). Consult with manufacturer for specific requirements.
- C. Do not install mortar, set or grout tile exterior when inclement weather conditions are expected within 48 hours after work is completed unless properly protected.
- D. Protection: Protect adjacent work surfaces during tile work. Close rooms or spaces to traffic of all types until mortar and grout have set.
- E. Safety: Observe the manufacturer's safety instructions including those pertaining to ventilation.

## 1.09 OPERATION AND MAINTENANCE DATA

Include recommended cleaning methods, cleaning materials, stain removal methods, and polishes and waxes.

## 1.10 EXTRA MATERIALS

Provide for Owner's use a minimum of 2 percent, but not less than one box, of the each of the sizes and colors of tile specified, boxed and clearly labeled.

## **PART 2 -- PRODUCTS**

### 2.01 MANUFACTURERS

- A. Tile: Standard grade, meeting the simplified Practice Recommendations F61-61, also Fed. Spec. SS-T-308B and ANSI A-137.1. Cartons grade sealed
- B. Acceptable Manufacturers:
  - 1. Arizona Tile [www.arizonatile.com](http://www.arizonatile.com) – Contact: Phil York (Architectural Sales Representative) @ (760) 321-2005, [pyork@arizonatile.com](mailto:pyork@arizonatile.com)
  - 2. Daltille [www.daltille.com](http://www.daltille.com) - Contact: Scott Chouinard (Architectural Sales Representative) @ (951) 757-4919, [scott.chouinard@daltille.com](mailto:scott.chouinard@daltille.com)
  - 3. Emser Stone and Tile, [www.emser.com](http://www.emser.com) – Contact: Lori Fisher (Architectural Sales Representative) @ (760) 834-2095, [lorifisher@emser.com](mailto:lorifisher@emser.com)
- C. Substitutions: Subject to the Architect's and Owner's sole determination if alternates are an acceptable equal to the items specified.

### 2.02 TILE

- A. General: Provide tile that complies with ANSI A137.1 for types, compositions and other characteristics indicated. Provide tile in the locations and of the types colors and pattern indicated on the Drawings and identified in the Schedule and the end of this Section. Tile shall also be provided in accordance with the following:
  - 1. Factory Blending: For tile exhibiting color variations within the ranges selected under Submittal of samples, blend tile in the factory and package so tile taken from one package shows the same range of colors as those taken from other packages.
  - 2. Mounting: For factory mounted tile, provide back or edge mounted tile assemblies as standard with the manufacturer, unless otherwise specified.
  - 3. Factory Applied Temporary Protective Coatings: Where indicated under tile type, protect exposed surfaces of tile against adherence of mortar and grout by pre-coating

with a continuous film of petroleum paraffin wax applied hot. Do not coat unexposed tile surfaces.

B. Material:

1. Furnish: size(s), color(s), pattern(s) and shape(s) as indicated on the drawings.
2. Trim Units: Matching bullnose, cove/inside finger cove, radius cap, sink rail, sink rail incorner/outcorner, cement bullnose, cove base, fabric bullnose, grooved bullnose, jolly shapes in sizes coordinated with field tile
3. Provide standard accessory shapes as required and as accepted by Architect.
4. Use appropriate trim shapes to conform to drawings.
5. Metal trims shall have a clear anodized finish – protected as to resist discoloration from adhesives and grouts.
6. Floor Tile: Shall meet the static coefficient of friction (COF) prescribed by ADAAG – 0.6 for level floors and 0.8 for ramps.

2.03 TRIM AND ACCESSORIES

Non-Ceramic Trim: Satin natural anodized extruded aluminum, stainless steel, brass, etc, style and dimensions to suit application, for setting using tile mortar or adhesive; use in the following locations:

1. Product: as indicated on the drawings.
2. Open edges of floor tile.
3. Transition between floor finishes of different heights.
4. Thresholds at door openings.
5. Expansion and control joints, floor and wall.

2.04 SETTING MATERIALS

A. Membranes: Liquid applied waterproof/crack isolation membrane (For Cracks Up To 1/8”):

1. Basis: Custom Building Products RedGard waterproof/crack isolation membrane.
2. Acceptable Products: Laticrete International Hydro Ban Floor and Wall Waterproofing & Crack Isolation & MAPEI Mapelastic AquaDefense.

B. Bonding Materials:

1. Bonded Mortar Bed Installations: Where indicated on the drawings, and elsewhere as required for mortar bed or brown coat as the substrate for tile work; work to conform to ANSI A108.1.
  - a. Portland cement: ASTM C 150, Type 1.
  - b. Sand: ASTM C 144.
  - c. Water: Potable, fresh.
  - d. Setting bed reinforcing mesh: 2-inch by 2-inch by 16/16, 3-inch by 3-inch by 13/13 or 1-1/2-inch by 2-inch by 16/13 wire complying with ASTM A 82 or A 185.
  - e. Latex modified dry-set mortar: The following or equal with physical properties equaling or exceeding those of the products specified.
  - f. Mortar Bed Bonding Mortar; Custom Building Products VersaBond mortar bed bonding mortar.
2. Medium Bed/Thin Set (Non Slumping) Mortar:

- a. Basis: Custom Building Products ProLite polymer modified thin set/medium bed mortar.
  - b. Acceptable Products: Laticrete International 255 MultiMax or MAPEI Large Floor Tile Mortar
- C. Grout:
  - 1. Portland cement grout:
    - a. Basis: Custom Building Products Polyblend Sanded Grout, ANSI A118.7 for joints 1/8 inch to 1/2 inch.
    - b. Acceptable Products: Laticrete International PermaColor Grout or MAPEI Ultracolor Plus Grout
  - 2. Epoxy Grout
    - a. Basis: Custom Building Products Polyblend Sanded Grout, ANSI A118.7 for joints 1/8 inch to 1/2 inch.
    - b. Acceptable Products: Laticrete International PermaColor Grout or MAPEI Ultracolor Plus Grout.
- D. Silicone Sealant: 100% Silicone Caulk by Custom Building Products or equal; color as indicated in drawings.
- E. Tile and Grout Sealer: Aqua Mix, Inc., Santa Fe Springs, CA
- F. Membrane at Walls – provide according to manufacturer requirements:
  - 1. No. 15 (6.9 kg) asphalt saturated felt, ASTM D226, Type 1.
  - 2. 4 mil (0.1 mm) thick polyethylene film, ASTM D4397.
  - 3. Reinforced asphalt paper.
- G. Reinforcing – provide according to manufacturer requirements:
  - 1. Mesh: 2 by 2 inch (50 by 50 mm) size weave of 16/16 wire size; welded fabric, galvanized.
  - 2. Metal Lath: ASTM C847, Flat expanded diamond mesh, not less than 2.5 lbs/SY, galvanized finish.
- H. Cementitious Backer Board: ANSI A118.9; High density, cementitious, 5/8" thick glass fiber reinforced with 2 inch (50 mm) wide coated glass fiber tape for joints and corners.

## **PART 3 -- EXECUTION**

### **3.01 EXAMINATION**

- A. Verify that wall surfaces are free of substances which would impair bonding of setting materials, smooth and flat within tolerances specified in ANSI A137.1, and are ready to receive tile.
- B. Verify that sub-floor surfaces are dust-free, and free of substances which would impair bonding of setting materials to sub-floor surfaces, and are smooth and flat within tolerances specified in ANSI A137.1.
- C. Verify that concrete sub-floor surfaces are ready for tile installation by testing for moisture emission rate and alkalinity; obtain instructions if test results are not within limits recommended by tile manufacturer and setting materials manufacturer.
- D. Verify that required floor-mounted utilities are in correct location.

- E. Perform subfloor moisture testing in accordance with as required by the Manufacturer. All test results shall be documented and retained.
- F. Perform pH tests on concrete floors regardless of their age or grade level as required by the Manufacturer. All test results shall be documented and retained.
- G. Report conditions contrary to contract requirements that would prevent a proper installation. Do not proceed with the installation until unsatisfactory conditions have been corrected.
- H. Failure to call attention to defects or imperfections will be construed as acceptance and approval of the conditions. Installation indicates acceptance of substrates with regard to conditions existing at the time of installation.

### 3.02 PREPARATION

#### A. General

1. Coordinate work with other trades as needed to assure that proper substrate are provided to receive work of this Section.
2. Before tiling, confirm variations of surface to be tiled fall within maximum variations shown below:
  - a. Cement Mortar Bed: ¼" in 8' for walls, ¼" in 10' for floors.
  - b. Epoxy Adhesive: 1/8" in 8' for walls, 1/8" in 10' for floors.
  - c. Organic Adhesive: 1/8" in 8' for walls, 1/8" in 8' for floors
3. Surfaces shall be clean and free of dust, oil, grease, paint, tar, wax, curing compound, primer, sealer, form release agent, laitance, loosely bonded topping, loose particles or any deleterious substance and debris which may prevent or reduce adhesion.
4. Patch any deep abrasions to the existing mortar bed substrate prior to skim coating and installing the new crack isolation membrane

#### B. Concrete Surface Preparation

1. All concrete substrates shall be at least 28 days old, completely cured and free of hydrostatic conditions, and/or moisture problems.
2. New concrete surfaces for dry-set mortar, medium-bed mortar or thick-bed mortar installations shall be wood floated or broom finished. Concrete walls should be bush-hammered or heavily sandblasted. On grade or below grade concrete slabs must be installed over an effective vapor barrier and be exempt from hydrostatic pressures.
3. Over excessively dry porous concrete, keep the concrete substrate continuously moist for at least 24 hours before work begins when using dry-set mortars or medium-bed mortars. Remove all excess water or standing water allowing the surface to become almost dry before installing the leveling coat, dry-set mortar or medium-bed dry-set mortar.
4. For minor repairs and smoothing up to 1/2 inch (12 mm), use Skim Coat & Patch Cement Underlayment or Speed Finish Patching & Finishing Compound.
5. For leveling of large areas use LevelLite Self-Leveling Underlayment for pours up to 2 inches (51 mm) thick, LevelQuik Rapid Setting Self-Leveling Underlayment for pours up to 1 inch (25 mm) thick or Extended Setting Self-Leveling Underlayment for pours up to 1 inch (25 mm) thick.
6. Custom Float Bedding Mortar mixed with water and Acrylic Mortar Admix to build-up or level a concrete substrate requiring a topping between 1/2 inch (12 mm) and 2 inch (50 mm) average thickness (see data sheet for details).



### 3.03 INSTALLATION - GENERAL

- A. Comply with current TCNA's "Handbook for Ceramic Tile Installation" for TCNA installation methods specified in tile installation schedules. Comply with parts of the ANSI A108 Series "Specifications for Installation of Ceramic Tile" that are referenced in TCNA installation methods, specified in tile installation schedules, and apply to types of setting and grouting materials used.
- B. Except as otherwise may be specified herein, all tile work shall conform with Standard Specifications A-108.1, A-108.4, A-108.5, A-108.6, A-108.9, A-108.10 issued by the American National Standards Institute.
- C. All tile shall be cut for proper fitting around work in place. Exposed edges of cuts shall be rubbed smooth with an abrasive stone. All tile shall be ground and carefully fitted at intersections against trim finish between fixtures and accessories. Tile shall be carefully fitted around outlets, pipes, fixtures, and fittings so that the plates, escutcheons, or collars all overlap the cut.
- D. Tile shall be kept free of stains before placing. Temporary guide strips shall be set with mortar or spot tiles shall be placed to fit the exact plans of each finish wall line. Mortar bed for interior glazed wall tile shall be not less than 3/8" thick and not more than 1/2" thick.
- E. Pattern of tile shall be accurately laid out and established working from center of each wall or space to assure equal size tiles on ends. Patterns shall be as noted on the drawings.
- F. All joints shall be grouted full, flush and smooth with the specified grout in accordance with the manufacturer's instructions.
- G. All walls shall be checked for plumb and all angles checked for square before tile work is started.

### 3.04 LIQUID MEMBRANE INSTALLATION

- A. Pre-treat Penetrations: Pack any gaps around pipes, lights or other penetrations with a compressible backer rod and suitable waterproof sealant. Apply a liberal coat of liquid around penetration opening. Embed pieces of 6" (15 cm) wide fabric into liquid. Cover with a second layer of liquid. After curing, seal flashing with a waterproof sealant.
- B. Expansion Joints: Cracks in excess of 1/8" (3 mm) should be treated as expansion joints. Carry these types of joints through any subsequent finishing material. Clean the joint and install open or closed cell backer rod to the proper depth as outlined in EJ 171 in the Tile Council Handbook. Next, compress a sealant as specified by the architect into the joint, coating the sides and leaving it flush with the surface. After the sealant is dry, place bond breaker tape over joint. Apply a minimum 3/64" (1.2 mm) of liquid over the joint and substrate. Install the tile work onto the membrane but do not bridge the joint. After the tile work is set properly, fill the joint with any specified color sealant, following the architect's and manufacturer's instructions.
- C. Pre-treat Drains:
  - 1. Drains should have a clamping ring with open weep holes for thin-set application. Cut a square of reinforcing fabric approximately 38" x 38" (96 x 96 cm). In the center of the fabric cut a hole that matches the diameter of the drain throat. Apply a liberal coat of liquid to the bottom flange. Drain should be fully supported without movement and even with plane of substrate.
  - 2. Center the circular cutout over the drain throat and embed the fabric into the liquid making sure it does not obstruct the drainage hole. Then apply an additional coat of liquid. Wet coat thickness should be 20 - 30 mils thick.
  - 3. After curing, apply a waterproof sealant bead where the fabric cutout meets the drain throat. Clamp upper flange onto membrane and tighten. Caulk with a silicone caulk around flange where membrane and upper flange make contact. A toilet flange can be handled in much the same manner.

### 3.05 SETTING MATERIALS INSTALLATION

- A. Specified medium bed setting materials may be installed up to 3/4 of an inch thick on horizontal surfaces.
- B. Apply mortar or adhesive with notched trowel using scraping motion to work material into good contact with the wall surface to be covered. Maintain 95 percent coverage on back of Tile and fully bed all corners.
- C. When installing natural stone Tiles, trowel a sufficient quantity of mortar adhesive onto back of each Tile.
- D. Maintain 95 percent coverage on back of the Tile and fully bed all corners.
- E. Apply only as much mortar or adhesive as can be covered within allowable windows as recommended by mortar or adhesive manufacturer or while surface is still tacky.
- F. Set Tiles in place and rub or beat with small beating block.
- G. Lightly beat or rap Tile to ensure proper bond and also to level surface of Tile.
- H. The setting materials must be free of voids to create a continuous, solid bond.
- I. Align Tile to show uniform joints and allow for setting until firm.
- J. Clean excess mortar or adhesive from surface of Tile with wet cheesecloth while mortar is fresh.

### 3.06 GROUT INSTALLATION

- A. Allow tile to set for a minimum of 48 hours prior to grouting. Remove all spacers, ropes, glue and foreign material prior to grouting.
- B. Follow grout manufacturer's recommendations as to grouting procedures and precautions.
  - 1. Force maximum amount of grout into joints in accordance with pertinent recommendations in ANSI 108.10.
  - 2. Fill-joints of cushion edged tile to depth of cushion; fill square edged tile flush with surface.
  - 3. Provide hard finished grout which is smooth and without voids, pinholes or low spots.
  - 4. Seal grout with specified penetrating sealer 48-72 hours after grout application.

### 3.07 JOINT INSTALLATION

- A. Provide expansion joints and other sealant-filled joints, including control, contraction, and isolation joints, where indicated. Form joints during installation of setting materials, mortar beds, and tile. Do not saw-cut joints after installing tiles.
- B. Where joints occur in concrete substrates, locate joints in tile surfaces directly above them.
- C. Joints must be carried through all layers of installation materials including tile, setting bed, mortar bed and reinforcing wire. Joints should be every 20 to 25 feet in both directions for interior installations and 8 to 12 feet in both directions for exterior installations. (Refer to TCA Handbook, EJ171 and ANSI AN-3.8 for details on placements, size and specifications of materials).

### 3.08 INSTALLATION - FLOORS - MORTAR BED METHODS

- A. Over interior concrete substrates, install in accordance with TCA Handbook Method F111, with cleavage membrane, unless otherwise indicated.
  - 1. Where waterproofing membrane is indicated, with standard grout or no mention of grout type, install in accordance with TCA Handbook Method F121.
  - 2. Where epoxy bond coat and grout are indicated, install in accordance with TCA

Handbook Method F132, bonded.

3. Where epoxy or furan grout is indicated, but not epoxy or furan bond coat, install in accordance with TCA Handbook Method F114, with cleavage membrane.

- B. Cleavage Membrane: Lap edges and ends.
- C. Waterproofing Membrane: Install as specified in ANSI A108.13.
- D. Mortar Bed Thickness: 1-1/4 to 2 inch (32 to 51 mm) maximum, unless otherwise indicated.

### 3.09 INSTALLATION - SHOWERS

- A. At tiled shower receptors install in accordance with TCA Handbook Method B415, mortar bed floor, and W244, thin-set over cementitious backer unit walls.
- B. Grout with standard grout as specified above.
- C. Seal joints between tile work and other work with sealant specified in Section 07900.

### 3.10 INSTALLATION - WALL TILE

- A. Over cementitious backer units on studs, install in accordance with TCA Handbook Method W244, using membrane at toilet rooms.
- B. Over gypsum wallboard on wood or metal studs install in accordance with TCA Handbook Method W243, thin-set with dry-set or latex-portland cement bond coat, unless otherwise indicated.
- C. Over wood studs without backer install in accordance with TCA Handbook Method W231, mortar bed, with membrane where indicated.
- D. Over metal studs without backer install in accordance with TCA Handbook Method W241, mortar bed, with membrane where indicated.

### 3.11 CLEANING

- A. Clean and seal all tile and grout surfaces.

### 3.12 PROTECTION OF FINISHED WORK

- A. Do not permit traffic over finished floor surface for 72 hours after installation.
- B. Cover floors with kraft paper and protect from dirt and residue from other trades.
- C. Where floor will be exposed for prolonged periods cover with plywood or other similar type walkways

**\*\*\*END OF SECTION\*\*\***

**THIS PAGE IS INTENTIONALLY BLANK**