

**SUBMITTAL TO THE BOARD OF SUPERVISORS
COUNTY OF RIVERSIDE, STATE OF CALIFORNIA**

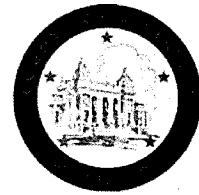

ITEM
3.53
(ID # 10665)

MEETING DATE:

Tuesday, August 27, 2019

FROM: TLMA-TRANSPORTATION:

SUBJECT: TRANSPORTATION AND LAND MANAGEMENT AGENCY/TRANSPORTATION
DEPARTMENT: Approve Addenda to the Plans and Specifications, Accept the Low Bid and Award the Contract for the Park Lane, Ridgeview Drive, North Circle Drive and Village Center Drive Resurfacing Projects, in the Community of Idyllwild. CEQA Exempt, District 3. [\$742,325 Total - Local Funds 100%]

RECOMMENDED MOTION: That the Board of Supervisors:

1. Find that the Park Lane, Ridgeview Drive (updated limits), North Circle Drive (updated limits) and Village Center Drive Resurfacing Projects are categorically exempt from the California Environmental Quality Act (CEQA) pursuant to State CEQA Guidelines Section 15301 (c) - Existing Facilities;
2. Direct the Clerk of the Board of Supervisors to file the Notice of Exemption with the County Clerk for posting within five (5) working days;
3. Approve two addenda to the plans and specifications issued prior to the August 8, 2019, bid opening;

ACTION:Policy

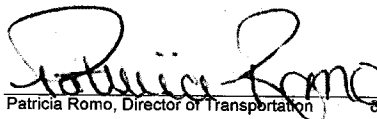
Patricia Romo, Director of Transportation 8/15/2019

MINUTES OF THE BOARD OF SUPERVISORS

On motion of Supervisor Washington, seconded by Supervisor Spiegel and duly carried by unanimous vote, IT WAS ORDERED that the above matter is approved as recommended.

Ayes: Jeffries, Spiegel, Washington, Perez and Hewitt
Nays: None
Absent: None
Date: August 27, 2019
xc: Transp.

Kecia R. Harper
Clerk of the Board
By: 
Deputy

**SUBMITTAL TO THE BOARD OF SUPERVISORS COUNTY OF RIVERSIDE,
STATE OF CALIFORNIA**

4. Accept the low bid of Hardy and Harper, Inc. of Lake Forest, California in the amount of \$742,325;
5. Award the contract to Hardy and Harper, Inc. and authorize the Chairman of the Board to execute the contract documents; and
6. Approve the project proposed budget as shown on Attachment "A".

FINANCIAL DATA	Current Fiscal Year:	Next Fiscal Year:	Total Cost:	Ongoing Cost
COST	\$ 742,325	\$ 0	\$ 742,325	\$ 0
NET COUNTY COST	\$ 0	\$ 0	\$ 0	\$ 0
SOURCE OF FUNDS: Gas Tax/ SB-1 (99%), Idyllwild Water District (1%). There are no General Funds used in this project.			Budget Adjustment: No	
			For Fiscal Year: 19/20	

C.E.O. RECOMMENDATION: Approve

BACKGROUND:

Summary

By Minute Order dated July 23, 2019 (Agenda Item 3.61), the County of Riverside (County) Board of Supervisors authorized the Clerk of the Board to advertise for the Park Lane, Ridgeview Drive, North Circle Drive and Village Center Drive Resurfacing Projects, in the Community of Idyllwild of the County of Riverside.

Roadway resurfacing is needed due to the deteriorated pavement conditions. The proposed resurfacing of Park Lane, Ridgeview Drive, North Circle Drive and Village Center Drive consists of grinding the existing pavement surface and replacing it with new hot-mix asphalt concrete pavement.

Additional improvements include reconstruction of concrete curb, sidewalk, driveway, curb ramps and asphalt concrete dike, installation of traffic striping, thermoplastic pavement markings, installation of traffic signs, and other associated work.

On April 28, 2017, Senate Bill 1 (SB-1) was passed to improve the State's aging transportation infrastructure, particularly roads and bridges. Because of this, the County is now able to improve the condition of roads in need of resurfacing or reconstruction and has included them in the County Transportation Improvement Program (TIP). Park Lane, Ridgeview Drive, North Circle Drive Resurfacing Project and Village Center Drive Resurfacing Project are two of Riverside County's priority projects approved for use of the new Gas Tax/SB-1 funds. Without SB-1 this needed road repair project would have been shelved until funding became available.

**SUBMITTAL TO THE BOARD OF SUPERVISORS COUNTY OF RIVERSIDE,
STATE OF CALIFORNIA**

The County of Riverside Transportation Department (Transportation Department) recommends award of the following schedules of work in the Contract amount of \$742,325:

Base Bid Schedule: Park Lane, Ridgeview Drive, North Circle Drive and Village Center Drive Resurfacing Projects

Alternate Bid Schedule 1: Idyllwild Water District (IWD), manholes adjustments to grade

The IWD has accepted the bid prices proposed by Hardy and Harper, Inc. for alternate bid schedule 1, and the cost for the work will be reimbursed by IWD through a reimbursement agreement. The Director of Transportation has the authority to sign reimbursement agreements up to \$50,000 per Minute Order dated February 28, 2006 (Agenda Item 3.52).

During the advertisement period, two addenda were issued to all registered plan holders as a supplement to the plans and specifications. Bidders were required to acknowledge and take into account the issued addenda on their contractor's Bid in order to be considered for award. The Addenda were issued to extend the resurfacing limits of Ridgeview Drive and North Circle Drive up to State Route 243; consequently, quantities for various items of work were increased. A date of completion by October 25, 2019 requirement was also issued by addendum. The addenda are attached and designated as Addendum No. 1 and Addendum No. 2.

The contractor, Hardy and Harper, Inc. is qualified to perform the work as outlined in the bid. The contractor will execute the Contract and provide bonds and insurance documents after Board of Supervisor award approval.

Project No. C1-0586, Park Lane, Ridgeview Drive, and North Circle Drive Resurfacing Project
C8-0057, Village Center Drive Resurfacing Project

Environmental findings: Revised Project Limits

Transportation Department extended the resurfacing limits of Ridgeview Drive and North Circle Drive up to State Route 243 by addendum, approximately 560 additional feet combined. The proposed project is exempt from CEQA under Section 15301 (c) because the resurfacing of the roadways and necessary safety improvements do not create additional automobiles lanes and involve negligible or no expansion of existing or former use of the existing roadway and associated facilities.

Impact on Residents and Businesses

The purpose of this project is to rehabilitate deteriorated segments of Park Lane and Village Center Drive, to provide the public with a smooth paved roadway that will improve the safety and efficiency of vehicular traffic.

The work is scheduled to begin in September of 2019. The work will be phased to keep the roads open during construction as much as possible and will take approximately five weeks to complete.

**SUBMITTAL TO THE BOARD OF SUPERVISORS COUNTY OF RIVERSIDE,
STATE OF CALIFORNIA**

SUPPLEMENTAL:

Additional Fiscal Information

The contract is recommended to be awarded to Hardy and Harper, Inc. for the total amount of \$742,325.

The project will be funded with Gas Tax/SB-1, and Idyllwild Water District funds.

The proposed budgets as shown on Attachment "A" includes the contract award amount and other associated costs.

There are no General Funds used in this project.

Contract History and Price Reasonableness

Four bids were received on Thursday, August 8, 2019 ranging from \$742,325 to \$1,234,000. The basis for the selection of a contractor is the lowest responsive and responsible bid. The lowest responsible bid was submitted by Hardy and Harper, Inc. in the amount of \$742,325, which is \$110,223 (17.4%) above the Engineer's Estimate.

The Transportation Department recommends the award of the contract to Hardy and Harper, Inc.

ATTACHMENTS:

Vicinity Map
Attachment A
Summary of Bids
Addendum No. 1
Addendum No. 2
Notice of Exemption with Journal Voucher
Contracts
Contractor's Bid Proposal



Jason Farin, Senior Management Analyst

8/22/2019

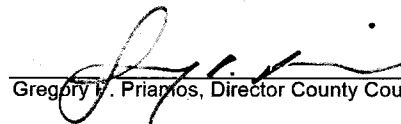

Gregory F. Priamos, Director County Counsel

8/20/2019

COUNTY OF RIVERSIDE
TRANSPORTATION DEPARTMENT

PARK LANE, RIDGEVIEW DRIVE AND NORTH CIRCLE DRIVE
RESURFACING PROJECT
VILLAGE CENTER DRIVE TO VILLAGE CENTER DRIVE; AND

VILLAGE CENTER DRIVE RESURFACING PROJECT
SOUTH CIRCLE DRIVE TO NORTH CIRCLE DRIVE

COMMUNITY OF IDYLLWILD

PROJECT No. C1-0586, C8-0057

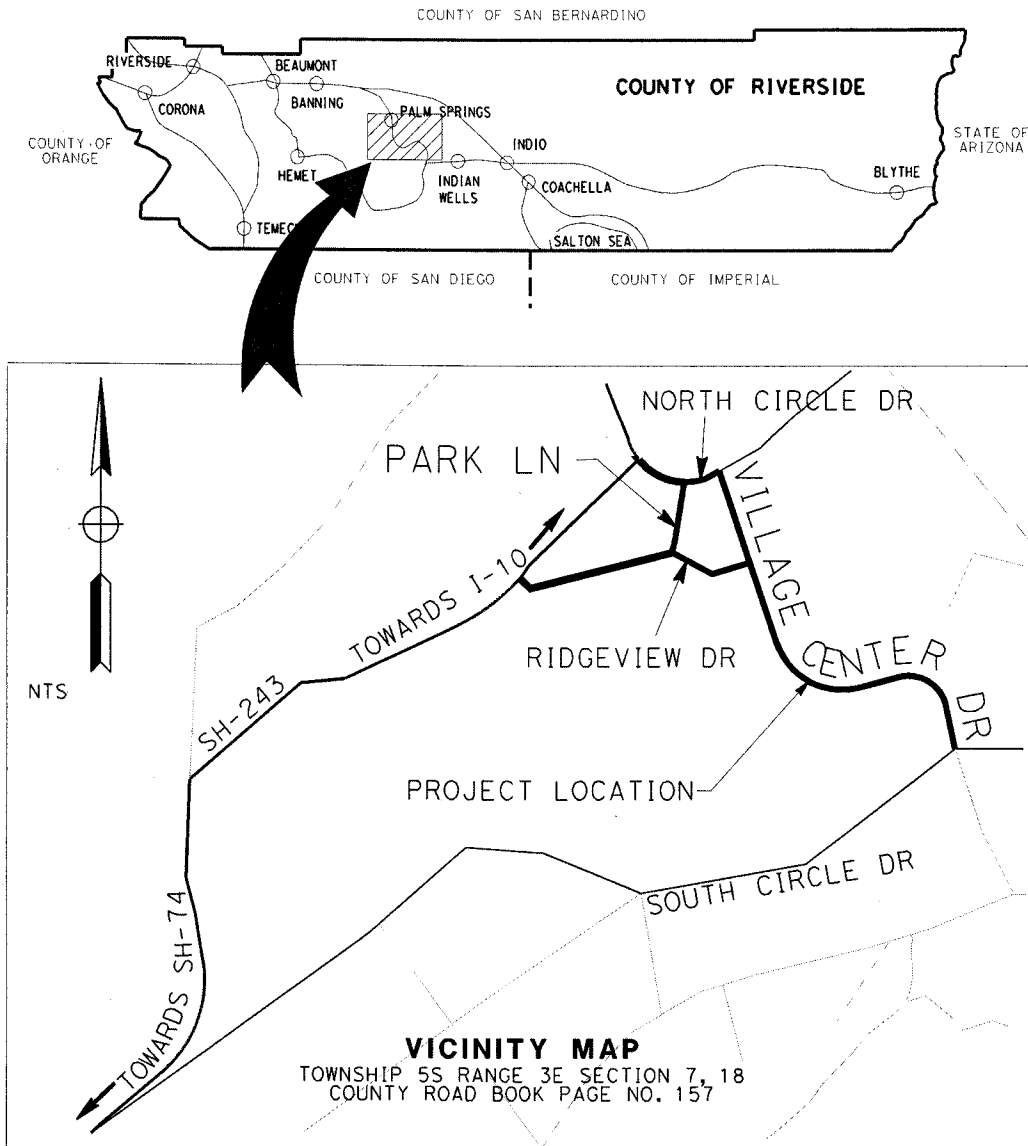

Attachment "A"

Riverside County Transportation Department

Project: **N. CIRCLE DR/PARK LN/RIDGEVIEW DR & VILLAGE CENTER DR
RESURFACING**

Project No.(s): **C1-0586, C8-0057**

Expenses as of: **8/8/2019**

Project Costs and Budget

Activity	Incurring Costs	Projected Costs	Total Costs	Existing Budget	Proposed Budget
Preliminary Survey					
Environmental	393	1,000	2,000	8,000	2,000
Design	112,551	5,000	118,000	163,000	118,000
Right-of-way					
Utilities					
Construction		742,326			
Construction Contingency	10.0%	74,233	817,000	500,000	817,000
Construction Engineering & Inspection	25.0%	1,516	184,484	150,000	186,000
Construction Survey	7.0%	52,000	52,000	30,000	52,000
Totals:		1,059,042	1,175,000	851,000	1,175,000

Project Funding

Code	Name	Existing Budget	Proposed Budget
223	Gas Tax/SB-1	851,000	1,166,000
990	Idyllwild Water District		9,000
Totals		851,000	1,175,000

Comments

Attachment A is a combination of both the C1-0586 Park Lane and C8-0057 Village Center Drive Resurfacing projects.

Printed: August 13, 19 9:16 AM

BY: Herbert D. Lima

**Riverside County Transportation Department
Summary of Bids**

PROJECT: Park Lane, Ridgeview Drive, and North Circle Drive Resurfacing Project
 Village Center Drive to Village Center Drive; and
Village Center Drive Resurfacing Project
 South Circle Drive to North Circle Drive
 Community of Idyllwild
 Project No. C1-0586, C8-0057

Advertised: July 23, 2019 (Agenda Item: 3.61)

Addenda: 1 (7/26/2019), 2 (8/2/2019)

Bids Open: 2 pm Date: Thursday, August 8, 2019

BASE BID SCH. - Park Lane, Ridgeview Drive and North Circle Drive; and Village Center Drive Resurfacing Projects		COUNTY'S ESTIMATE			Hardy & Harper, Inc. Lake Forest, CA 92630			
ITEM NO.	ITEM CODE	CONTRACT ITEM	UNITS	QUANTITY	UNIT PRICE	ENG ESTIMATE	BID UNIT PRICE	BID ESTIMATE
1	100100	DEVELOP WATER SUPPLY	LS	1	5,000.00	5,000.00	5,000.00	5,000.00
2	120100	TRAFFIC CONTROL SYSTEM	LS	1	30,000.00	30,000.00	30,000.00	30,000.00
3	130200	PREPARE WATER POLLUTION CONTROL PROGRAM	LS	1	5,000.00	5,000.00	7,500.00	7,500.00
4	170103	CLEARING AND GRUBBING	LS	1	10,000.00	10,000.00	10,000.00	10,000.00
5	066012	DUST ABATEMENT	LS	1	5,000.00	5,000.00	25,000.00	25,000.00
6	374207	CRACK TREATMENT	LS	1	15,000.00	15,000.00	28,700.00	28,700.00
7	031500	RELOCATE BUSINESS SIGN	EA	1	300.00	300.00	2,500.00	2,500.00
8	190185	SHOULDER BACKING	LF	1,480	3.00	4,440.00	8.00	11,840.00
9	013902	ASPHALT CONCRETE OVERSIDE DRAIN (CRS 306)	EA	2	1,500.00	3,000.00	4,444.00	8,888.00
10	013903	PLACE ASPHALT CONCRETE DIKE (CRS 212) (6")	LF	430	15.00	6,450.00	20.00	8,600.00
11	390132	HOT MIX ASPHALT (TYPE A)	TON	2,970	90.00	267,300.00	88.50	262,845.00
12	394076	PLACE HOT MIX ASPHALT DIKE (TYPE E)	LF	720	15.00	10,800.00	23.00	16,560.00
13	394090	PLACE HOT MIX ASPHALT (MISCELLANEOUS AREA)	SQYD	40	30.00	1,200.00	150.00	6,000.00
14	398200	COLD PLANE ASPHALT CONCRETE PAVEMENT	SQYD	11,250	4.00	45,000.00	6.25	70,312.50
15	510080	STRUCTURAL CONCRETE, APPROACH SLAB	CY	33	2,000.00	66,000.00	2,060.00	67,980.00
16	710100	ABANDON CULVERT	EA	1	2,000.00	2,000.00	10,700.00	10,700.00
17	723080	ROCK SLOPE PROTECTION (60 lb, Class II, METHOD B)	CY	7	100.00	700.00	1,632.00	11,424.00
18	017304	MINOR CONCRETE (CURB AND GUTTER) (CRS 200)	LF	500	40.00	20,000.00	70.00	35,000.00
19	017316	MINOR CONCRETE (CURB RAMP) (CRS 403 - CASE B)	EA	2	5,000.00	10,000.00	6,000.00	12,000.00
20	731516	MINOR CONCRETE (DRIVEWAY)	SQFT	825	15.00	12,375.00	12.00	9,900.00
21	731521	MINOR CONCRETE (SIDEWALK)	SQFT	1,400	15.00	21,000.00	8.00	11,200.00

**Riverside County Transportation Department
Summary of Bids**

PROJECT: Park Lane, Ridgeview Drive, and North Circle Drive Resurfacing Project
 Village Center Drive to Village Center Drive, and
Village Center Drive Resurfacing Project
 South Circle Drive to North Circle Drive
Community of Idyllwild
Project No. C1-0586, C8-0057

Advertised: July 23, 2019 (Agenda Item: 3.61)
Addenda: 1 (7/26/2019), 2 (8/2/2019)
Bids Open: 2 pm Date: Thursday, August 8, 2019

BASE BID SCH. - Park Lane, Ridgeview Drive and North Circle Drive, and Village Center Drive Resurfacing Projects		COUNTY'S ESTIMATE				1		
ITEM NO.	ITEM CODE	CONTRACT ITEM	UNITS	QUANTITY	UNIT PRICE	ENG ESTIMATE	BID UNIT PRICE	BID ESTIMATE
22	780433	PAINT CURB (2-COAT)	LF	130	5.00	650.00	3.00	390.00
23	803170	RELOCATE FENCE	LF	40	60.00	2,400.00	89.00	3,560.00
24	820410	SALVAGE ROADSIDE SIGN	EA	4	200.00	800.00	74.00	296.00
25	820840	ROADSIDE SIGN - ONE POST	EA	4	300.00	1,200.00	787.00	3,148.00
26	840515	THERMOPLASTIC PAVEMENT MARKING	SQFT	2,855	5.00	14,275.00	3.15	8,993.25
27	840656	PAINT TRAFFIC STRIPE (2-COAT)	LF	6,070	1.00	6,070.00	0.74	4,491.80
28	846025	REMOVE PAINTED PAVEMENT MARKING	SQFT	71	2.00	142.00	7.00	497.00
29	010602	MISCELLANEOUS WORK (AS DIRECTED)	FA	1	60,000.00	60,000.00	60,000.00	60,000.00
BASE BID SCH. TOTAL ITEMS 1 - 29						626,102.00		733,325.55

ALTERNATIVE BID SCH. 1 - Idyllwild Water District

ITEM NO.	ITEM CODE	CONTRACT ITEM	UNITS	QUANTITY	UNIT PRICE	ENG ESTIMATE	BID UNIT PRICE	BID ESTIMATE
30	710212	ADJUST MANHOLE TO GRADE	EA	6	1,000.00	6,000.00	1,500.00	9,000.00
ALT. BID SCH. 1 TOTAL ITEM 30						6,000.00		9,000.00

PROJECT TOTAL ITEMS 1 - 30						632,102.00		742,325.55
---------------------------------------	--	--	--	--	--	-------------------	--	-------------------

**Riverside County Transportation Department
Summary of Bids**

PROJECT: Park Lane, Ridgeview Drive, and North Circle Drive Resurfacing Project
 Village Center Drive to Village Center Drive; and
Village Center Drive Resurfacing Project
 South Circle Drive to North Circle Drive
Community of Idyllwild
Project No. C1-0586, C8-0057

Advertised: July 23, 2019 (Agenda Item: 3.61)
Addenda: 1 (7/26/2019), 2 (8/2/2019)

Bids Open: 2 pm Date: Thursday, August 8, 2019

ITEM NO.	ITEM CODE	CONTRACT ITEM	2			3		
			UNITS	QUANTITY	BID UNIT PRICE	BID ESTIMATE	BID UNIT PRICE	BID ESTIMATE
1	100100	DEVELOP WATER SUPPLY	LS	1	5,000.00	5,000.00	5,000.00	5,000.00
2	120100	TRAFFIC CONTROL SYSTEM	LS	1	30,000.00	30,000.00	96,500.00	96,500.00
3	130200	PREPARE WATER POLLUTION CONTROL PROGRAM	LS	1	7,500.00	7,500.00	7,500.00	7,500.00
4	170103	CLEARING AND GRUBBING	LS	1	10,000.00	10,000.00	20,000.00	20,000.00
5	066012	DUST ABATEMENT	LS	1	22,109.00	22,109.00	8,100.00	8,100.00
6	374207	CRACK TREATMENT	LS	1	15,000.50	15,000.50	16,800.00	16,800.00
7	031500	RELOCATE BUSINESS SIGN	EA	1	500.00	500.00	5,600.00	5,600.00
8	190185	SHOULDER BACKING	LF	1,480	9.00	13,320.00	9.00	13,320.00
9	013902	ASPHALT CONCRETE OVERSIDE DRAIN (CRS 306)	EA	2	500.00	1,000.00	3,650.00	7,300.00
10	013903	PLACE ASPHALT CONCRETE DIKE (CRS 212) (6")	LF	430	7.00	3,010.00	8.00	3,440.00
11	390132	HOT MIX ASPHALT (TYPE A)	TON	2,970	121.00	359,370.00	150.00	445,500.00
12	394076	PLACE HOT MIX ASPHALT DIKE (TYPE E)	LF	720	7.00	5,040.00	8.00	5,760.00
13	394090	PLACE HOT MIX ASPHALT (MISCELLANEOUS AREA)	SQYD	40	110.00	4,400.00	167.00	6,680.00
14	398200	COLD PLANE ASPHALT CONCRETE PAVEMENT	SQYD	11,250	5.00	56,250.00	13.00	146,250.00
15	510080	STRUCTURAL CONCRETE, APPROACH SLAB	CY	33	1,300.00	42,900.00	1,440.00	47,520.00
16	710100	ABANDON CULVERT	EA	1	10,000.00	10,000.00	7,400.00	7,400.00
17	723080	ROCK SLOPE PROTECTION (60 lb, Class II, METHOD B)	CY	7	800.00	5,600.00	665.00	4,655.00
18	017304	MINOR CONCRETE (CURB AND GUTTER) (CRS 200)	LF	500	50.00	25,000.00	101.00	50,500.00
19	017316	MINOR CONCRETE (CURB RAMP) (CRS 403 - CASE B)	EA	2	7,000.00	14,000.00	10,200.00	20,400.00
20	731516	MINOR CONCRETE (DRIVEWAY)	SQFT	825	15.00	12,375.00	22.00	18,150.00
21	731521	MINOR CONCRETE (SIDEWALK)	SQFT	1,400	10.00	14,000.00	15.00	21,000.00

**Riverside County Transportation Department
Summary of Bids**

PROJECT: Park Lane, Ridgeview Drive, and North Circle Drive Resurfacing Project
 Village Center Drive to Village Center Drive; and
Village Center Drive Resurfacing Project
 South Circle Drive to North Circle Drive
Community of Idyllwild
Project No. C1-0586, C8-0057

Advertised: July 23, 2019 (Agenda Item: 3.61)
Addenda: 1 (7/26/2019), 2 (8/2/2019)
Bids Open: 2 pm Date: Thursday, August 8, 2019

BASE BID SCH. - Park Lane, Ridgeview Drive and North Circle Drive; and Village Center Drive Resurfacing Projects		2 Granite Construction Company Indio, CA 92203		3 All American Asphalt Corona, CA 92878					
ITEM NO.	ITEM CODE	CONTRACT ITEM	UNITS	QUANTITY	BID ESTIMATE	BID UNIT PRICE	BID ESTIMATE	BID UNIT PRICE	BID ESTIMATE
22	780433	PAINT CURB (2-COAT)	LF	130	325.00	3.20	416.00		
23	803170	RELOCATE FENCE	LF	40	3,400.00	60.00	2,400.00		
24	820410	SALVAGE ROADSIDE SIGN	EA	4	220.00	79.00	316.00		
25	820840	ROADSIDE SIGN - ONE POST	EA	4	1,500.00	845.00	3,380.00		
26	840515	THERMOPLASTIC PAVEMENT MARKING	SQFT	2,855	12,847.50	3.40	9,707.00		
27	840656	PAINT TRAFFIC STRIPE (2-COAT)	LF	6,070	3,035.00	0.80	4,856.00		
28	846025	REMOVE PAINTED PAVEMENT MARKING	SQFT	71	355.00	7.00	497.00		
29	010602	MISCELLANEOUS WORK (AS DIRECTED)	FA	1	60,000.00	60,000.00	60,000.00		
BASE BID SCH. TOTAL ITEMS 1 - 29					738,057.00		1,038,947.00		

ALTERNATIVE BID SCH. 1 - Idyllwild Water District

ITEM NO.	ITEM CODE	CONTRACT ITEM	UNITS	QUANTITY	UNIT PRICE	ENG ESTIMATE	BID UNIT PRICE	BID ESTIMATE
30	710212	ADJUST MANHOLE TO GRADE	EA	6	2,000.00	12,000.00	1,500.00	9,000.00
ALT. BID SCH. 1 TOTAL ITEM 30						12,000.00		9,000.00

PROJECT TOTAL ITEMS 1 - 30					750,057.00		1,047,947.00
---------------------------------------	--	--	--	--	-------------------	--	---------------------

**Riverside County Transportation Department
Summary of Bids**

PROJECT: Park Lane, Ridgeview Drive, and North Circle Drive Resurfacing Project
 Village Center Drive to Village Center Drive; and
Village Center Drive Resurfacing Project
 South Circle Drive to North Circle Drive
Community of Idyllwild
Project No. C1-0586, C8-0057

Advertised: July 23, 2019 (Agenda Item: 3.61)

Addenda: 1 (7/26/2019), 2 (8/2/2019)

Bids Open: 2 pm Date: Thursday, August 8, 2019

BASE BID SCH. - Park Lane, Ridgeview Drive and North Circle Drive; and Village Center Drive Resurfacing Projects		Onyx Paving Company, Inc. Address 4				
ITEM NO.	ITEM CODE	CONTRACT ITEM	UNITS	QUANTITY	BID UNIT PRICE	BID ESTIMATE
1	100100	DEVELOP WATER SUPPLY	LS	1	6,000.00	6,000.00
2	120100	TRAFFIC CONTROL SYSTEM	LS	1	196,000.00	196,000.00
3	130200	PREPARE WATER POLLUTION CONTROL PROGRAM	LS	1	10,000.00	10,000.00
4	170103	CLEARING AND GRUBBING	LS	1	76,000.00	76,000.00
5	066012	DUST ABATEMENT	LS	1	6,000.00	6,000.00
6	374207	CRACK TREATMENT	LS	1	21,011.50	21,011.50
7	031500	RELOCATE BUSINESS SIGN	EA	1	5,000.00	5,000.00
8	190185	SHOULDER BACKING	LF	1,480	13.00	19,240.00
9	013902	ASPHALT CONCRETE OVERSIDE DRAIN (CRS 306)	EA	2	3,000.00	6,000.00
10	013903	PLACE ASPHALT CONCRETE DIKE (CRS 212) (6")	LF	430	27.00	11,610.00
11	390132	HOT MIX ASPHALT (TYPE A)	TON	2,970	123.00	365,310.00
12	394076	PLACE HOT MIX ASPHALT DIKE (TYPE E)	LF	720	27.00	19,440.00
13	394090	PLACE HOT MIX ASPHALT (MISCELLANEOUS AREA)	SQYD	40	275.00	11,000.00
14	398200	COLD PLANE ASPHALT CONCRETE PAVEMENT	SQYD	11,250	11.00	123,750.00
15	510080	STRUCTURAL CONCRETE, APPROACH SLAB	CY	33	3,000.00	99,000.00
16	710100	ABANDON CULVERT	EA	1	22,000.00	22,000.00
17	723080	ROCK SLOPE PROTECTION (60 lb, Class II, METHOD B)	CY	7	2,000.00	14,000.00
18	017304	MINOR CONCRETE (CURB AND GUTTER) (CRS 200)	LF	500	95.00	47,500.00
19	017316	MINOR CONCRETE (CURB RAMP) (CRS 403 - CASE B)	EA	2	9,500.00	19,000.00
20	731516	MINOR CONCRETE (DRIVEWAY)	SQFT	825	27.00	22,275.00
21	731521	MINOR CONCRETE (SIDEWALK)	SQFT	1,400	16.00	22,400.00

**Riverside County Transportation Department
Summary of Bids**

PROJECT: Park Lane, Ridgeview Drive, and North Circle Drive Resurfacing Project
 Village Center Drive to Village Center Drive; and
Village Center Drive Resurfacing Project
 South Circle Drive to North Circle Drive
Community of Idyllwild
Project No. C1-0586, C8-0057

Advertised: July 23, 2019 (Agenda Item: 3.61)
Addenda: 1 (7/26/2019), 2 (8/2/2019)
Bids Open: 2 pm Date: Thursday, August 8, 2019

BASE BID SCH. - Park Lane, Ridgeview Drive and North Circle Drive; and Village Center Drive Resurfacing Projects		Onyx Paving Company, Inc. Address 4				
ITEM NO.	ITEM CODE	CONTRACT ITEM	UNITS	QUANTITY	BID UNIT PRICE	BID ESTIMATE
22	780433	PAINT CURB (2-COAT)	LF	130	5.00	650.00
23	803170	RELOCATE FENCE	LF	40	300.00	12,000.00
24	820410	SALVAGE ROADSIDE SIGN	EA	4	42.00	168.00
25	820840	ROADSIDE SIGN - ONE POST	EA	4	1,420.00	5,680.00
26	840515	THERMOPLASTIC PAVEMENT MARKING	SQFT	2,855	6.00	17,130.00
27	840656	PAINT TRAFFIC STRIPE (2-COAT)	LF	6,070	0.55	3,338.50
28	846025	REMOVE PAINTED PAVEMENT MARKING	SQFT	71	7.00	497.00
29	010602	MISCELLANEOUS WORK (AS DIRECTED)	FA	1	60,000.00	60,000.00
BASE BID SCH. TOTAL ITEMS 1 - 29						1,222,000.00

ALTERNATIVE BID SCH. 1 - Idyllwild Water District

ITEM NO.	ITEM CODE	CONTRACT ITEM	UNITS	QUANTITY	UNIT PRICE	ENG ESTIMATE
30	710212	ADJUST MANHOLE TO GRADE	EA	6	2,000.00	12,000.00
ALT. BID SCH. 1 TOTAL ITEM 30						12,000.00

PROJECT TOTAL ITEMS 1 - 30						1,234,000.00
---------------------------------------	--	--	--	--	--	---------------------



Patricia Romo, P.E.
Director of Transportation

COUNTY OF RIVERSIDE

TRANSPORTATION AND LAND MANAGEMENT AGENCY

Mojahed Salama, P.E.
Deputy for Transportation/Capital Projects
Richard Lantis, P.L.S.
Deputy for Transportation/Planning and
Development

Transportation Department

ADDENDUM NUMBER 1

Dated July 26, 2019

to the
Specifications and Contract Documents
for the construction of

Park Lane, Ridgeview Drive and North Circle Drive
Resurfacing Project

Village Center Drive to Village Center Drive; and

Village Center Drive Resurfacing Project
South Circle Drive to North Circle Drive

Community of Idyllwild
Project No. C1-0586, C8-0057

Bids Due: Thursday, August 8, 2019; 2:00 p.m.
14th Street Transportation Annex
3525 14th Street; Riverside, CA 92501
(951) 955-6780

This Addendum is issued pursuant to the Instructions to Bidders, Item No. 8, of the Contract Documents for the reference project. This Addendum is issued as a supplement to the specification and special provisions for the referenced project. The revisions to the specifications shall become a part of the Contract Documents, and each bidder shall acknowledge receipt thereof on the Bid (Proposal). Bidders are directed to sign this addendum as acknowledged and attach the signed addendum to the contractor's submitted proposal.

Note: During the advertisement period of this project, this document and attachments (if any) are available upon request at the office of the Transportation Department, and are available as a free download at the Transportation Department's website:

<http://rctlma.org/trans/Contractors-Corner/Notices-Inviting-Bids>

MODIFICATIONS / CLARIFICATIONS TO SPECIAL PROVISIONS:

Item 1: Revised Engineering Estimate Range. Refer to the "Notice to Bidders" on page v of the bid documents. Delete the Engineering Estimate ranges found on page v of the "Notice to Bidders" and replace them with the following:

Engineering Estimate:	\$562,000 - \$655,000	(Base Bid Schedule)
	\$ 5,400 - \$ 6,300	(Alternative Bid Schedule)

Item 2: Revised Proposal. Refer to "Proposal" pages B2 and B3 of the bid documents. Delete and replace proposal (pages B2 and B3) with "Proposal (Revised)" attached herewith as **Attachment "A"**.

- a. The quantities for the following item are revised:
 - Item 8, SHOULDER BACKING
 - Item 10, PLACE ASPHALT CONCRETE DIKE (CRS 212) (6")
 - Item 11, HOT MIX ASPHALT (TYPE A)
 - Item 13, PLACE HOT MIX ASPHALT (MISCELLANEOUS AREA)
 - Item 14, COLD PLANE ASPHALT CONCRETE PAVEMENT
 - Item 18, MINOR CONCRETE (CURB AND GUTTER) (CRS 200)
 - Item 20, MINOR CONCRETE (DRIVEWAY)
 - Item 21, MINOR CONCRETE (SIDEWALK)
 - Item 26, THERMOPLASTIC PAVEMENT MARKING
 - Item 27, PAINT TRAFFIC STRIPE (2-COAT)
 - Item 30, ADJUST MANHOLE TO GRADE

Item 3: Project Description. Refer to Section 00-1.01 "Project Description," of the special provisions (page 1). Delete the segment limits for Ridgeview Drive and North Circle Drive and replace them with the following limits:

Ridgeview Drive - State Route 243 to Village Center Drive

North Circle Drive - State Route 243 to Village Center Drive

Item 4: Encroachment Permit. Refer to Section 00-1.07 "Encroachment Permit," of the special provisions (page 3 and 4).

- Delete City of Riverside reference found in the third paragraph:

Contractor to submit Traffic Control plans and WPCP to Caltrans and ~~City of Riverside~~ for review and approval prior to issuance of Encroachment Permit.

- Delete the Payment paragraph on page 4 and replace it with the following Payment paragraph:

Payment:

If the Contractor pays any fees to Caltrans to obtain Encroachment Permit, then full compensation for the actual cost of the Encroachment Permit fees, as paid by the Contractor to Caltrans, shall be considered as included in the force account contract price for Miscellaneous Work (As directed). No markups will be allowed. All incidental costs incurred by the Contractor shall be considered as included in the various items of work and no compensation will be allowed therefor.

Item 5: Work Sequencing. Refer to Section 10-1.02 "Work Sequencing," of the special provisions (page 3 and 4). The following notices are added:

Repairs on State Route 74 and 243 near Idyllwild and Mountain Center

Due to flood repairs, State Route 243 between Idyllwild and Banning is expected to be closed during construction of the project; additionally, State Route 74 between Hemet and Mountain Center is also expected to be closed during construction of the project.

At State Route 74, pilot cars are available to escort vehicles through the road closure only between the hours of 4:00 AM and 8:00 AM, and between 6:00 PM and 12:00 AM. Contractors shall consider these road closure and plan their work and material deliveries in accordance with these road restrictions.

Item 6: Public Outreach / Public Meetings. Refer to Section 12-5.01, "Traffic Control System/ Public Convenience/ Public Safety," subsection 12-5.04, "Public Outreach," of the special provisions (page 18).

The following provisions are added to subsection 12-5.04, "Public Outreach":

The Contractor shall be required to coordinate with Connect & Company PR for public outreach. As directed by the Resident Engineer, the Contractor shall be available to attend Public Meetings in order to inform the residents of the progress of the project, to provide information on lane closures, and to answer questions. The cost of attending these meetings shall be included in the cost of performing traffic control and no additional compensation will be provided therefor.

Connect & Company PR contact information will be made available to the awarded contractor during the pre-construction meeting.

Item 7: Clarification, Placement and Reconstruction of Asphalt Concrete Dike.

The contract unit bid price paid per linear foot for Place Asphalt Concrete Dike (CRS 212) 6" and Place Hot Mix Asphalt Dike (Type E) includes full compensation for placement of new asphalt concrete dike and for reconstruction of existing asphalt concrete dike as required.

Addendum No. 1

Park Lane, Ridgeview Drive and North Circle Drive Resurfacing Project, Village Center Drive to Village Center Drive, and; Village Center Drive Resurfacing Project, South Circle Drive to North Circle Drive

Community of Idyllwild, Project No. C1-0586, C8-0057

July 26, 2019

Page 4 of 5

MODIFICATIONS / CLARIFICATIONS TO THE PLANS

Item 8: Plan sheets added, revised. The following plan sheets are added or revised by **Attachment "B"** and are made a part hereby:

1. Plan sheet 5A of 7, L-3A, Layout (Added)
2. Plan sheet 7 of 7, PD-2, Pavement Delineation & Sign Plan (Revised)

ATTACHMENTS

A – Revised Proposal (2 pages)

B – Added / Revised Plans (2 Sheet)

Addendum No. 1

Park Lane, Ridgeview Drive and North Circle Drive Resurfacing Project, Village Center Drive to Village Center Drive,
and; Village Center Drive Resurfacing Project, South Circle Drive to North Circle Drive
Community of Idyllwild, Project No. C1-0586, C8-0057

July 26, 2019
Page 5 of 5

This addendum has been prepared under the direction of the following registered Civil Engineer(s):

Recommended by:

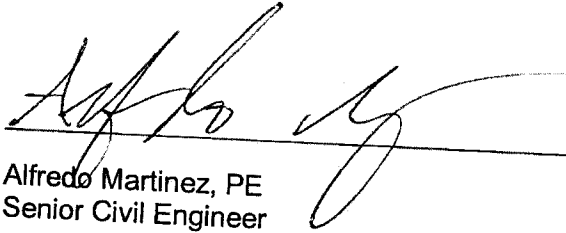
Alfredo Martinez, PE
Senior Civil Engineer



Concurrence:

Khalid Nasim, PE
Engineering Division Manager

Acknowledged: _____ **Date:** _____
(Contractor)

JRJ: jrj:rr

Note: Refer to Instruction to Bidders Item No. 8, "Addenda". Submission of all addendum pages and non-bidding document attachments of addendum are not necessary for Bid submittal. Submittal of this acknowledgement page is adequate for Bid reception. Bidders are reminded to list addendum number(s) received on the first page of the Bid form (Proposal).

**Park Lane, Ridgeview Drive, and North Circle Drive
Resurfacing Project**

ISSUED BY ADDENDUM No. 1
ATTACHMENT "A"

**Village Center Drive to Village Center Drive; and
Village Center Drive Resurfacing Project**

South Circle Drive to North Circle Drive
Community of Idyllwild

Project No. C1-0586, C8-0057

REVISED PROPOSAL

ITEM No.	ITEM CODE	ITEM	UNIT	ESTIMATED QUANTITY	ITEM PRICE (IN FIGURES)	TOTAL (IN FIGURES)
BASE BID SCHEDULE - Park Lane, Ridgeview Drive and North Circle Drive; and Village Center Drive Resurfacing Projects						
1	100100	DEVELOP WATER SUPPLY	LS	1		
2	120100	TRAFFIC CONTROL SYSTEM	LS	1		
3	130200	PREPARE WATER POLLUTION CONTROL PROGRAM	LS	1		
4	170103	CLEARING AND GRUBBING	LS	1		
5	066012	DUST ABATEMENT	LS	1		
6	374207	CRACK TREATMENT	LS	1		
7	031500	RELOCATE BUSINESS SIGN	EA	1		
8	190185	SHOULDER BACKING	LF	1,480		
9	013902	ASPHALT CONCRETE OVERSIDE DRAIN (CRS 306)	EA	2		
10	013903	PLACE ASPHALT CONCRETE DIKE (CRS 212) (6")	LF	430		
11	390132	HOT MIX ASPHALT (TYPE A)	TON	2,970		
12	394076	PLACE HOT MIX ASPHALT DIKE (TYPE E)	LF	720		
13	394090	PLACE HOT MIX ASPHALT (MISCELLANEOUS AREA)	SQYD	40		
14	398200	COLD PLANE ASPHALT CONCRETE PAVEMENT	SQYD	11,250		
15	510080	STRUCTURAL CONCRETE, APPROACH SLAB	CY	33		
16	710100	ABANDON CULVERT	EA	1		
17	723080	ROCK SLOPE PROTECTION (60 lb, Class II, METHOD B)	CY	7		
18	017304	MINOR CONCRETE (CURB AND GUTTER) (CRS 200)	LF	500		

ADDENDUM No. 1, Page 6 of 9

REVISED PROPOSAL

ISSUED BY ADDENDUM No. 1
ATTACHMENT "A"

ITEM No.	ITEM CODE	ITEM	UNIT	ESTIMATED QUANTITY	ITEM PRICE (IN FIGURES)	TOTAL (IN FIGURES)
BASE BID SCHEDULE - Park Lane, Ridgeview Drive and North Circle Drive and Village Center Drive Resurfacing Projects (continued)						
19	017316	MINOR CONCRETE (CURB RAMP) (CRS 403 - CASE B)	EA	2		
20	731516	MINOR CONCRETE (DRIVEWAY)	SQFT	825		
21	731521	MINOR CONCRETE (SIDEWALK)	SQFT	1,400		
22	780433	PAINT CURB (2-COAT)	LF	130		
23	803170	RELOCATE FENCE	LF	40		
24	820410	SALVAGE ROADSIDE SIGN	EA	4		
25	820840	ROADSIDE SIGN - ONE POST	EA	4		
26	840515	THERMOPLASTIC PAVEMENT MARKING	SQFT	2,855		
27	840656	PAINT TRAFFIC STRIPE (2-COAT)	LF	6,070		
28	846025	REMOVE PAINTED PAVEMENT MARKING	SQFT	71		
29	010602	MISCELLANEOUS WORK (AS DIRECTED)	FA	1	60,000.00	60,000.00

BASE BID TOTAL: _____
ITEMS 1 - 29 "WORDS" \$ _____

ALTERNATIVE BID SCHEDULE 1 - IDYLLWILD WATER DISTRICT

30	710212	ADJUST MANHOLE TO GRADE	EA	6		
----	--------	-------------------------	----	---	--	--

ALT. BID 1 TOTAL: _____
ITEM 30 "WORDS" \$ _____

PROJECT TOTAL: _____
ITEMS 1 - 30 "WORDS" \$ _____

ADDENDUM No. 1, Page 7 of 9

CONSTRUCTION NOTES:

- 1 PROTECT
- 2 MATCH EXISTING
- 3 SAW CUT
- 4 ADJUST WATER VALVE TO GRADE
- 5 ADJUST MANHOLE TO GRADE BY IWD
- 6 RECONSTRUCT AC PATHWAY
- 7 RECONSTRUCT 6" CONCRETE CURB & GUTTER PER STD No. 200
- 8 RECONSTRUCT 6" DIKE PER STD 212
- 9 RECONSTRUCT CONCRETE DRIVEWAY APPROACH PER STD No. 207
- 10 COLD PLANE EXISTING ASPHALT CONCRETE TO A DEPTH OF 1 1/2" OVER 1 1/2" GRANULAR FILL WITH A MINIMUM OF 1/2" THEN COVER WITH 3" MIN. HDPE W/PC 44-10
- 11 GRADE SHOULDER AND PLACE 6" MIN SHOULDER BACKING

STRIPING NOTES:

- 1 PAINT NO PASSING ZONE STRIPES MARKERS PER 2014 CA MUTCD FIGURE 3A-104(CA), DETAIL 21
- 2 REMOVE EXISTING STRIPING MARKERS PER MUTCD 2014 THROUGHOUT PROJECT
- 3 SHOW ALL STRIPING, STRIPES, AND WORDS, WHITE EXCEPT NOTED OTHERWISE

SIGNING NOTES:

- 1 PROTECT SIGN
- 2 REMOVE/SALVAGE SIGN
- 3 INSTALL SIGN (STD No. 1221 TO BE USED WHEN INSTALLING SNS)

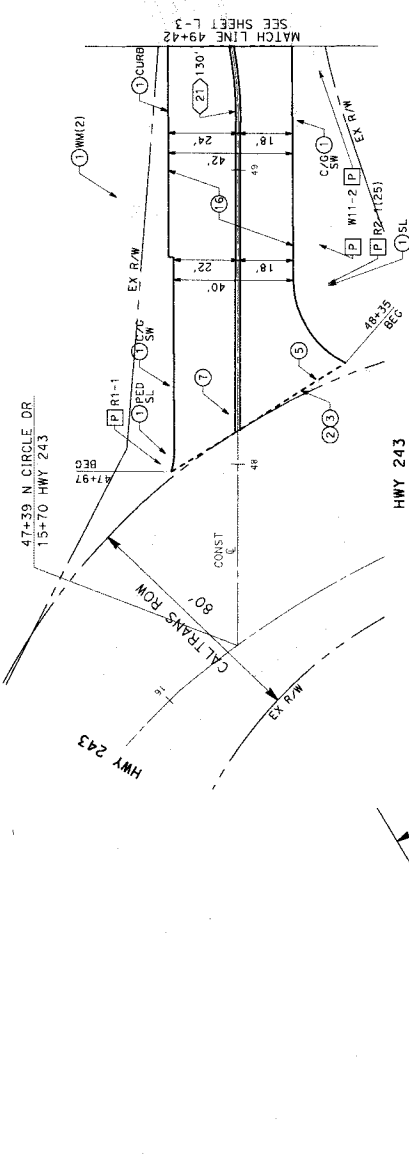
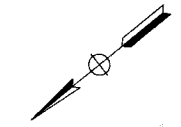

N CIRCLE DR

RIDGEVIEW DR

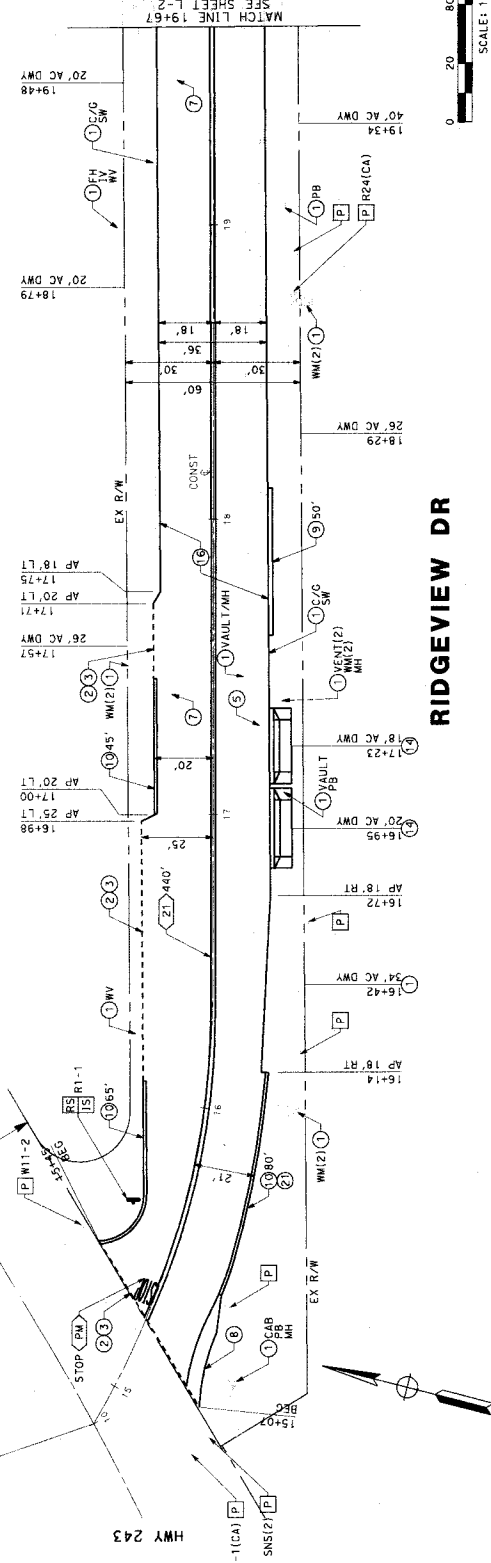

SIGN SIZE
R1-1 36" X 36"

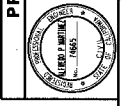

PREPARED BY
ALBERT J. MARTIN
7/22/15
DATE

LAYOUT
VILLAGE CENTER DR, PARK LN,
RIDGEVIEW DR, & N. CIRCLE DR
RESURFACING

SHEET NO.
L-3A
SHEET 5A OF 7

PROJECT NO. C08-0086, C8-0087
COUNTY FILE NO. 967-M

BORDER LAST REVISED 07/21/2015

ISSUED BY ADDENDUM NO. 1, ATTACHMENT B

DATE PLOTTED => 7/22/2015
TIME PLOTTED => 12:02:48 PM

STRIPING NOTES:

- (Z1) PAINT 4" NO PASSING ZONE STRIPES AND 12" CALTRANS PER 2010 CALTRANS STD PLAN A20A, DETAIL 2.
- (Z7B) PAINT 6" EDGE LINE STRIPE PER 2018 CALTRANS STD PLAN A20B, DETAIL 27B.
- (39) PAINT 6" BIKELANE STRIPE PER 2018 CALTRANS STD PLAN A20B, DETAIL A20D.
- (41) PAINT 4" CENTER LINE EXTENSIONS THROUGH CALTRANS PER 2010 CALTRANS STD PLAN A20A, DETAIL 41.
- (LL) INSTALL THERMOPLASTIC LIMIT LINES PER 2018 CALTRANS STD PLAN A24E.
- (XR) INSTALL CROSSWALK LINE PER 2018 CALTRANS STD PLAN A24F "BASIC" @ 11'.
- (XW) INSTALL CROSSWALK LINE PER 2018 CALTRANS PLAN STD A24F "LADDER" @ 11' O.C. WITH STRIPE SHOWN IN DETAIL XWL.
- (PM) INSTALL PAVEMENT MARKINGS AS SHOWN PER CALTRANS STD A24D FOR WORDS.
- (RW) REMOVE EXISTING TYPIC STRIPES, PAVEMENT MARKINGS AND/OR THERMOPLASTIC PAVEMENT.
- (PR) PAINT CURB RED FROM 10" PRIOR BCR TO ECR.

SIGNING NOTES:

- (P) PROTECT SIGN
- (RS) REMOVE/SALVAGE SIGN
- (S) INSTALL SIGN (STD NO. 1221 TO BE USED WHEN INSTALLING SNS)

SIGN SIZE	
SNS	VARIES
R1-1	30" X 30"
8" UPPERCASE, 6" LOWERCASE	

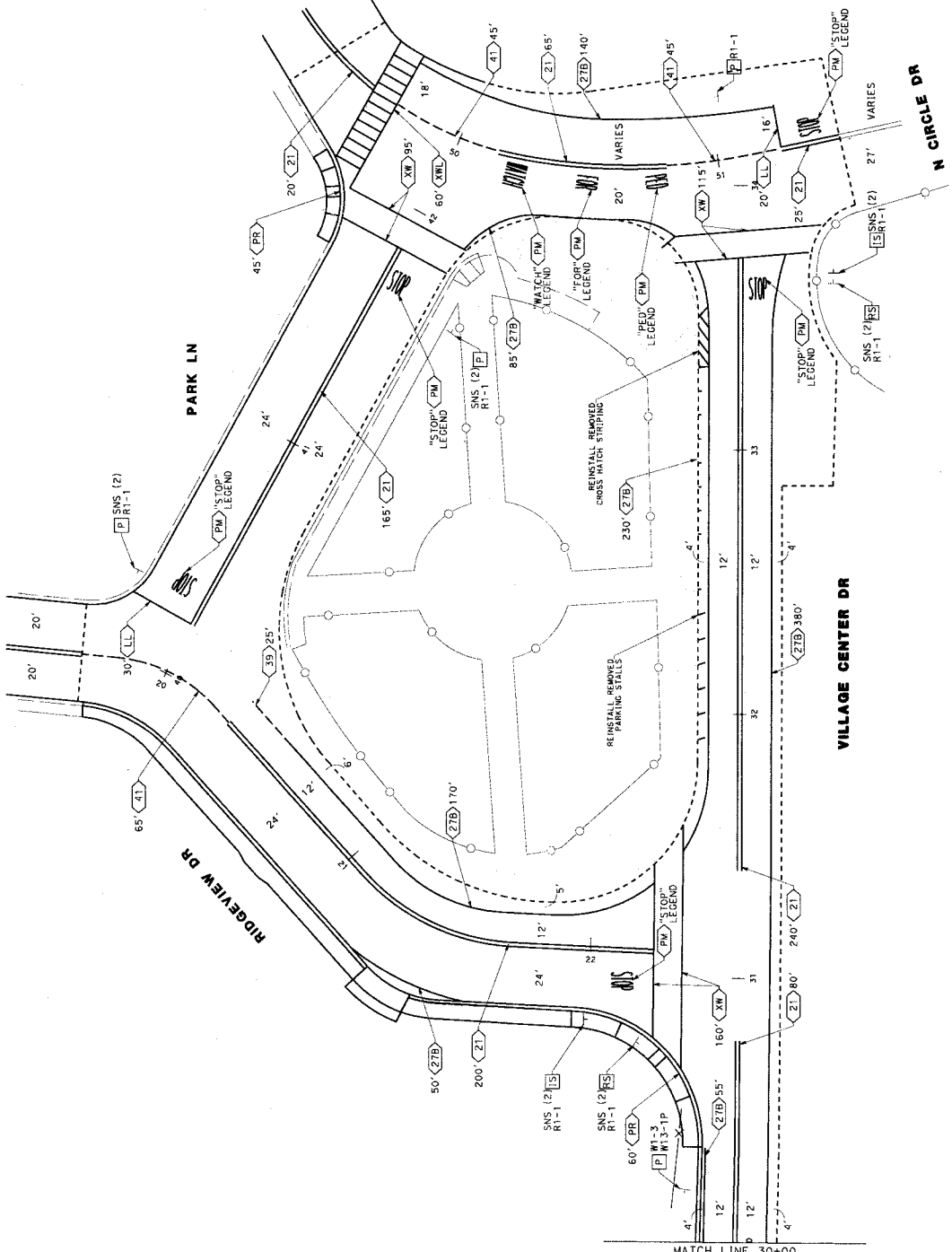
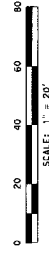
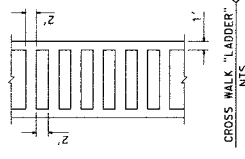

MATCH LINE 30+00
SEE SHEET PD-1
VILLAGE CENTER DR

PREPARED BY [Signature]
PAVEMENT DELINEATION & SIGN PLAN SHEET NO. PD-2
VILLAGE CENTER DR
 30+00 TO 33+77
N. CIRCLE DR, PARK LN, & RIDGEVIEW DR
 SHEET 7 OF 7
 COUNTY OF RIVERSIDE
 PROJECT MANAGER
 DATE
 PREPARED UNDER THE SUPERVISION OF:
 [Signature]
 COUNTY OF RIVERSIDE
 PROJECT MANAGER
 DATE
 DRAWING NO. 05-0057
 BOOK FILE # 05-0057
 WO C1-0586, C8-0057
 COUNTY FILE NO. 967-M

BARRIER LAST REVISED 07/21/2015



Patricia Romo, P.E.
Director of Transportation

COUNTY OF RIVERSIDE

TRANSPORTATION AND LAND MANAGEMENT AGENCY

Mojahed Salama, P.E.
Deputy for Transportation/Capital Projects
Richard Lantis, P.L.S.
Deputy for Transportation/Planning and
Development

Transportation Department

ADDENDUM NUMBER 2

Dated August 2, 2019

to the
Specifications and Contract Documents
for the construction of

Park Lane, Ridgeview Drive and North Circle Drive
Resurfacing Project

Village Center Drive to Village Center Drive; and

Village Center Drive Resurfacing Project
South Circle Drive to North Circle Drive

Community of Idyllwild
Project No. C1-0586, C8-0057

Bids Due: Thursday, August 8, 2019; 2:00 p.m.
14th Street Transportation Annex
3525 14th Street; Riverside, CA 92501
(951) 955-6780

This Addendum is issued pursuant to the Instructions to Bidders, Item No. 8, of the Contract Documents for the reference project. This Addendum is issued as a supplement to the specification and special provisions for the referenced project. The revisions to the specifications shall become a part of the Contract Documents, and each bidder shall acknowledge receipt thereof on the Bid (Proposal). Bidders are directed to sign this addendum as acknowledged and attach the signed addendum to the contractor's submitted proposal.

Note: During the advertisement period of this project, this document and attachments (if any) are available upon request at the office of the Transportation Department, and are available as a free download at the Transportation Department's website:

<http://rctlma.org/trans/Contractors-Corner/Notices-Inviting-Bids>

MODIFICATIONS / CLARIFICATIONS TO SPECIAL PROVISIONS:

Item 1: 00-1.03 Time of Completion. Refer to the section 00-1.03 Time of Completion on page 2 of Special Provisions. Following additional requirement added to this provision and made part thereof.

The Contractor must complete the project by October 25, 2019. The County anticipate to award this project on August 27, 2019.

Attention is directed to section 00-1.04 Liquidated Damages on page 2 of Special Provisions to be aware of consequences of project delay. Liquidated damages will be applicable for each and every calendar day delay after October 25, 2019.

Note: No work shall be allowed on Friday October 11, 2019 due to Annual Art Walk and Wine Tasting Festival.

Addendum No. 2

Park Lane, Ridgeview Drive and North Circle Drive Resurfacing Project, Village Center Drive to Village Center Drive, and; Village Center Drive Resurfacing Project, South Circle Drive to North Circle Drive

Community of Idyllwild, Project No. C1-0586, C8-0057

August 2, 2019

Page 2 of 3

Item 2: 00-1.07 Encroachment Permit. Refer to section "00-1.07 Encroachment Permit" on page 3 of the Special Provisions.

The copy of Caltrans' issued encroachment permit is being provided for bidder's information and compliance. The encroachment permit is attached herewith as **Attachment "A"**.

ATTACHMENTS

A – Caltrans Encroachment Permit (8 pages)

Addendum No. 2

Park Lane, Ridgeview Drive and North Circle Drive Resurfacing Project, Village Center Drive to Village Center Drive, and; Village Center Drive Resurfacing Project, South Circle Drive to North Circle Drive
Community of Idyllwild, Project No. C1-0586, C8-0057

August 2, 2019
Page 3 of 3

This addendum has been prepared under the direction of the following registered Civil Engineer(s):

Recommended by:

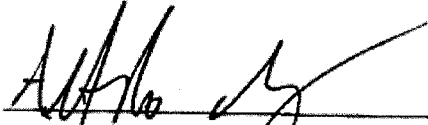

Alfredo Martinez, PE
Senior Civil Engineer

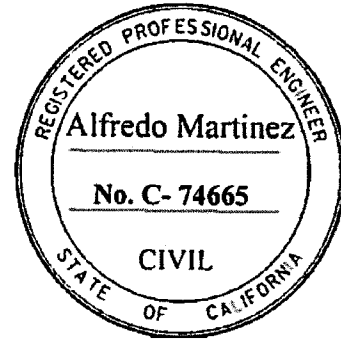

Concurrence:



Khalid Nasim, PE
Engineering Division Manager

Acknowledged: _____ **Date:** _____
(Contractor)

JRJ: jrj:rr

Note: Refer to Instruction to Bidders Item No. 8, "Addenda". Submission of all addendum pages and non-bidding document attachments of addendum are not necessary for Bid submittal. Submittal of this acknowledgement page is adequate for Bid reception. Bidders are reminded to list addendum number(s) received on the first page of the Bid form (Proposal).

Permit No. 08-19-N-TK-0934	
Dist/Co/Rte/PM 08-RIV-243, PM 4.3/4.5	
Permit Approval Date 08/01/2019	
Fee Paid \$ EXEMPT	Deposit \$ EXEMPT
Performance Bond Amount (1) \$ 0.00	Payment Bond Amount (2) \$ 0.00
Bond Company	
Bond Number (1)	Bond Number (2)

In compliance with (Check one):

- Your application of _____ July 25, 2019
- Utility Notice No. _____ of _____
- Agreement No. _____ of _____
- RW Contract No. _____ of _____

TO: County of Riverside Transportation Department
 3525 14th Street
 Riverside, CA 92501
 Attn: Alfredo Martinez 951-955-0086

, PERMITTEE

and subject to the following, PERMISSION IS HEREBY GRANTED to:

Enter onto State Route 243 right of way between Ridgeview Drive and Pine Crest Avenue in Riverside County, to place temporary traffic control signs impacted by work outside of Caltrans right of way, as per plans date stamped July 30, 2019 by the California Department of Transportation (Caltrans) District 8 Encroachment Permits Office and/or to the satisfaction of the Caltrans Representative.

Notwithstanding General Provision #4, your contractor is required to apply for and obtain an encroachment permit prior to starting work. A fee/deposit of \$492.00 for inspection is required at the time of application.

A pre-job meeting with the assigned Caltrans Representative, Martin Morris, (909) 383-4207, is required at least 7 days prior to start of any work under this permit. Failure to do so may result in permit revocation with no prejudice.

THIS PERMIT IS NOT A PROPERTY RIGHT AND DOES NOT TRANSFER WITH THE PROPERTY TO A NEW OWNER.

The following attachments are also included as part of this permit (Check applicable):

- Yes No General Provisions
- Yes No Utility Maintenance Provisions
- Yes No Storm Water Special Provisions
- Yes No Special Provisions
- Yes No A Cal-OSHA permit, if required: Permit No. _____
- Yes No As-Built Plans Submittal Route Slip for Locally Advertised Projects
- Yes No Storm Water Pollution Prevention Plan / Water Pollution Control Plan

In addition to fee, the permittee will be billed actual costs for:

- Yes No Review
- Yes No Inspection
- Yes No Field Work

(if any Caltrans effort expended)

Yes No The information in the environmental documentation has been reviewed and considered prior to approval of this permit.

This permit is void unless the work is completed before _____

This permit is to be strictly construed and no other work other than specifically mentioned is hereby authorized.

No project work shall be commenced until all the other necessary permits and the environmental clearances have been obtained.

PERMIT ENGINEER: Reza Moslemi
 COPIES TO:
 Maintenance: Banning 710
 EP Inspector: Martin Morris
 File: 19-0943

APPROVED:

Michael D. Beauchamp, District Director

BY:



ANDY QUACH, P.E., District Permit Engineer

ADA Notice

For individuals with sensory disabilities, this document is available in alternate formats. For alternate format information, contact the Forms Management Unit at (916) 445-1233, TTY 711, or write to Records and Forms Management, 1120 N Street, MS-89, Sacramento, CA 95814.

PAGE 1: ATTACHED TO AND MADE PART OF PERMIT NO. 08-19-N-TK-0934

In addition to the attached General Provisions, the following checked special provisions are applicable:

A PRE-JOB MEETING WITH THE ASSIGNED CALTRANS REPRESENTATIVE, Martin Morris (909) 383-4207 AT LEAST 7 DAYS IS REQUIRED PRIOR TO START OF ANY WORK UNDER THIS PERMIT. FAILURE TO DO SO WILL RESULT IN PERMIT CANCELLATION AND RESUBMITTAL MAY BE REQUIRED.

Notwithstanding General Provision #4, your contractor is required to apply for and obtain an encroachment permit prior to starting work. A fee/deposit of \$ [redacted] for inspection, and \$ [redacted] for electrical equipment is required at the time of application.

You are required to submit an approved Storm Water Pollution Prevention Plan (SWPPP) for projects with a cumulative disturbed soil area equal or greater than 1 acre, and an approved Water Pollution Control Program (WPCP) for projects with a disturbed soil area less than 1 acre, unless otherwise required by other agencies (RWQCBs, U.S. Army Corps of Engineers, Department of Fish and Game, etc.).

Upon the expiration of this permit, the Permittee is required to apply for the countywide annual maintenance permit for this new facilities installed under the Permit No.: [redacted].

The Permittee is required to apply for a separate permit to maintain and/or replace in kind of these facilities on each occurrence upon the expiration of this permit.

The Permittee shall provide the stage construction traffic handling plans, work schedule and a list of all sub-contractors to the Department's Representative at the time of the pre-construction meeting or prior to start construction.

All traffic control, signing and striping shall comply with California MUTCD 2014. It is available at: http://www.dot.ca.gov/hq/traffops/signtech/mutcdsupp/ca_mutcd.htm

Permittee and his/her contractors shall comply with Department 2018 Standard Specifications, Department 2018 Standard Plans, and all the latest revisions implemented as of this permit issued date, and the project specific special provisions for Oversight Projects and Streamlined Oversight Projects. It is the responsibility of the permittee and his/her contractors to verify with the Department Standard Plans, Standard Specifications, and all the latest revisions as of this permit issued date before ordering any materials for the project within the Department Right-Of-Way. The Department Standard Plans, Standard Specifications, and the Revisions are available at: <http://www.dot.ca.gov/hq/esc/oe/standards.php>

Permittee and/or permittee's authorized contractor/agent are required and responsible to identify the Department's underground electrical systems before performing any excavation work within the right of way.

All personnel shall wear hard hats and orange or lime vests, shirts or jackets as appropriate while on State property.

The Permittee's work shall be subordinated to any operations which the Department may conduct and shall not delay, nor interfere with the Department's Forces or Department's Contractors.

ADDENDUM No. 2, Page 5 of 11

PAGE 2: ATTACHED TO AND MADE PART OF PERMIT NO. 08-19-N-TK-0934

Attention is directed to Standard Specifications Section 7-1.11, Preservation of Property, and Business and Professions Code, Section 8771. The Permittee shall physically inspect the work site and locate survey monuments prior to work commencement. Monuments shall be referenced or reset in accordance with the Business and Professions Code.

Except for installing, maintaining and removing traffic control devices, any work encroaching within 3 feet of the edge of a traffic lane for areas with a posted speed limit below 45mph, or 6 feet of the edge of a traffic lane, for areas with a speed limit posted at 45mph or higher, shall require closing of the adjacent traffic lane. Permittee shall notify the Department's Representative, and obtain approval of, all traffic control, lane closures or detours, at least seven (7) WORKING DAYS prior to setting up of any traffic control.

No lane may be closed or obstructed at any time unless specifically allowed per the encroachment permit, shown in approved traffic control plans, and/or as directed by the Department's Representative.

Traffic control is generally authorized between 9:00 AM and 3:00 PM only on Monday through Thursday and until 1:00 PM on Fridays, excluding holidays except specified in the Permit. Lane closure is not allowed on Saturdays, Sundays and designated holidays. The designated holidays are: January 1st, the third Monday in January, the second and third Mondays in February, March 31, the last Monday in May, July 4th, the first Monday in September, the second Monday in October, November 11th, Thanksgiving Day, the day after Thanksgiving Day, and December 25th. When a fixed holiday falls on Saturday, the preceding Friday shall be designated as holiday.

Should any deviation from these procedures or conditions be observed, all work shall be suspended until satisfactory steps have been taken to ensure compliance.

If time extension is necessary, a request for time extension and the accompanying attachments must be made a minimum of two (2) weeks prior to completion date stated on face of permit. If work has not been started before completion date, the permit will be voided. Failure to comply with rules and regulations stated on permit will jeopardize future permit privileges.

"AS-BUILT" PLANS ARE REQUIRED UPON COMPLETION OF ALL WORK. PLEASE REFER TO THE GENERAL PROVISION TR-0045, ITEM 22 FOR THE "AS-BUILT" REQUIREMENTS. NO FINAL INSPECTION WILL BE PERFORMED UNTIL THE DEPARTMENT IS IN RECEIPT OF "AS-BUILT" PLANS.

No vehicle or equipment shall be stored overnight within the right of way; it shall be removed immediately at the completion of the day's work. Refueling of vehicle or equipment within the right of way is strictly prohibited.

Required traffic control devices shall be installed around fixed objects to warn the motoring public for safety. Personal vehicles of the contractor shall not be parked within freeway right of way.

No materials or waste shall be stockpiled within State right of way.

Except as specifically provided herein, all requirements of the Vehicle Code and other applicable laws must be complied with in all particulars.

When traffic cones or delineators are used to delineate a temporary edge of traffic lane, the line of cones or delineators shall be considered to be the edge of the traffic lane. The permittee shall not reduce the width of the existing lane to less than 10 feet without written approval from the Department's Representative.

PAGE 3: ATTACHED TO AND MADE PART OF PERMIT NO. 08-19-N-TK-0934

Excavations made within the limits of the right of way shall be backfilled and resurfaced to original condition before leaving the work area unless otherwise authorized by the Department's Representative.

All trenches repair shall comply with ENCROACHMENT PERMIT TRENCH DETAIL, TR-0153 or to the satisfaction of the Department's Representative.

Permittee shall be responsible for arranging the services of a qualified traffic control contractor to provide any needed traffic control.

The permittee shall arrange a meeting between his field representative, traffic control contractor, Department's Representative and/or CHP at least two (2) weeks prior to start of any work covered under this permit to arrange date and time of starting work and determine appropriate methods of handling traffic. At least 3 working days notice shall be given to the Caltrans representative and/or the CHP, prior to the meeting to allow time to arrange for attendance.

A copy of this permit, complete with all attachments, shall be kept by permittee/contractor working under this permit and must be shown to the Department Permit Inspector, Department's Representatives, or Law Enforcement Officer, on demand.

The permittee shall be responsible for notifying the appropriate utility companies or underground service alert prior to any excavation work.

The permittee shall notify the California Highway Patrol Area Commander at least 72 hours prior to implementing traffic control.

When the work area encroaches upon a sidewalk, walkway, or crosswalk area, special consideration must be given to pedestrian safety. Protective barricades, fencing, handrails and bridges, together with warning and guidance devices and signs must be utilized so that the passageway for pedestrians, especially blind and other physically handicapped, is safe and well defined and shown on the approved permit plan.

Pedestrian walkways and canopies within State Right of Way shall comply with the requirements of the applicable local agency or of the latest edition of the Uniform Building Code whichever contains the higher standards.

[For City or County projects with utility relocations:]

If existing public or private utilities conflict with the construction PROJECT, PERMITTEE will make necessary arrangements with the owners of such utilities for their protection, relocation, or removal. PERMITTEE shall inspect the protection, relocation, or removal of such facilities. Total costs of such protection, relocation, or removal which STATE or PERMITTEE must legally pay, will be borne by PERMITTEE. If any protection, relocation, or removal of utilities is required, including determination of liability for cost, such work shall be performed in accordance with STATE policy and procedure. PERMITTEE shall require any utility company performing relocation work in the STATE's right-of-way to obtain a State Encroachment Permit before the performance of said relocation work. Any relocated utilities shall be correctly located and identified on the as-built plans.

[For other projects with utility relocations:]

If existing public or private utilities conflict with the construction PROJECT, PERMITTEE will make necessary arrangements with the owners of such utilities for their protection, relocation, or removal. PERMITTEE

PAGE 4: ATTACHED TO AND MADE PART OF PERMIT NO. 08-19-N-TK-0934

shall inspect the protection, relocation, or removal of such facilities. Total costs of such protection, relocation, or removal shall be borne by PERMITTEE in compliance with the terms of the Highway Encroachment Permits, Case Law, Public Utility Regulations, and Property Rights. PERMITTEE shall require any utility company performing relocation work in the STATE's right-of-way to obtain a State Encroachment Permit before the performance of said relocation work. Any relocated utilities shall be correctly located and identified on the as-built plans.

PAGE 5: ATTACHED TO AND MADE PART OF PERMIT NO. 08-19-N-TK-0934

PERMIT NO.: 08-19-N-TK-0934

CO/RTE/PM: 08-RIV-243-4.3-4.5

PRECONSTRUCTION MEETING AGREEMENT

I, _____, acting as an authorized agent for the permittee, _____, do hereby agree to personally accomplish or have another designated person arrange for all involved company representatives to attend a pre-construction meeting with the authorized Department's Representative at _____, as specified on this permit. Such meeting must be held two (2) days or more prior to the planned start of the work on this project. The Authorized Department's Representative shall have complete authority to determine whether the permit conditions, either implied or written, have been complied with. The Department's Representative may then allow the permit work to proceed as appropriate. The Pre-construction Meeting Record below must be signed by both the Department's Representative and the permittee before the permit work may start.

I have read and understand the attached General Provisions TR-0045 and other attached provisions of this permit.

This agreement or a copy thereof, must be mailed back to the Department's District 8 Encroachment Permit Office at 464 W. 4th. Street, MS 619, San Bernardino, CA 92401-1400, within three (3) working days prior to the pre-construction meeting. Failure to return this form could delay the release of your bonds. A copy of this document shall be at the job site at all times when work is in progress and failure to do so may result in the suspension of work, as directed by the Department's Representative.

It is the permittee's responsibility to insure that the Department's Representative is notified of work completion and that the attached Completion Notice is mailed to the Department's Permit office.

Signature Date

Print or Type Name

Position or Title

ADDENDUM No. 2, Page 9 of 11

Bid

Date: 08/06/2019

To: County of Riverside, hereafter called "County";

Bidder: Hardy & Harper, Inc.
(hereafter called "Contractor")

The undersigned, Contractor, having carefully examined the site and the Contract Documents for the construction of Park Lane, Ridgeview Drive and North Circle Drive, Resurfacing Project, Village Center Drive to Village Center Drive; and Village Center Drive Resurfacing Project, South Circle Drive to North Circle Drive, Community of Idyllwild, Project No. C1-0586, C8-0057 hereby proposes to construct the work in accordance with the Contract Documents, including Addenda Number(s) 2 (Fill in addenda numbers if addenda have been issued.) for the amount stated in this Bid.

By submitting this Bid, Contractor agrees with County:

1. That unless withdrawn in person by Contractor or some person authorized in writing by Contractor (not by telephone or facsimile) before the time specified in the Notice Inviting Bids for the public opening of bids, this Bid constitutes an irrevocable offer for 90 calendar days after that date.
2. County has the right to reject any or all Bids and to waive any irregularities or informalities contained in a Bid.
3. To execute the Contract and deliver the Performance Bond, Payment Bond and Insurance Certificate with endorsements, that comply with the requirements set forth in the Instruction to Bidders and General Conditions, within ten (10) business days of the date of the Notice of Acceptance of Bid and Intent to Award as issued by the County.
4. That the contract shall be awarded upon a resolution or minute order to that effect duly adopted by the governing body of County; and that execution of the Contract shall constitute a written memorial thereof.
5. To submit to the County such information as County may require determining whether a particular Bid is the lowest responsible bid submitted.
6. That the accompanying Bid Bond, certified check or cashier's check is in an amount not less than 10% of the total bid submitted and constitutes a guarantee that if awarded the contract, Contractor will execute the Contract and deliver the required bonds within ten (10) business days after notice of award. If Contractor fails to execute and deliver said documents, the bond or check is to be charged with the costs of the resultant damages to the County, including but not limited to: publication costs, the difference in money between the amount bid and the amount in excess of the bid which it costs County to do or cause to be done for the work involved, lease and rental costs, additional salaries and overhead, increased interest and costs of funding the project, attorney expense, additional engineering and architectural expense and cost of maintaining or constructing alternate facilities occasioned by the failure to execute and deliver said documents.
7. By signing this Bid the Contractor certifies that the representations made therein are made under penalty of perjury.

**Park Lane, Ridgeview Drive, and North Circle Drive
Resurfacing Project**
Village Center Drive to Village Center Drive; and
Village Center Drive Resurfacing Project
South Circle Drive to North Circle Drive
Community of Idyllwild
Project No. C1-0586, C8-0057

REVISED PROPOSAL

ITEM No.	ITEM CODE	ITEM	UNIT	ESTIMATED QUANTITY	ITEM PRICE (IN FIGURES)	TOTAL (IN FIGURES)
----------	-----------	------	------	--------------------	-------------------------	--------------------

BASE BID SCHEDULE - Park Lane, Ridgeview Drive and North Circle Drive; and Village Center Drive Resurfacing Projects

1	100100	DEVELOP WATER SUPPLY	LS	1	5,000	5,000
2	120100	TRAFFIC CONTROL SYSTEM	LS	1	30,000	30,000
3	130200	PREPARE WATER POLLUTION CONTROL PROGRAM	LS	1	7,500	7,500
4	170103	CLEARING AND GRUBBING	LS	1	10,000	10,000
5	066012	DUST ABATEMENT	LS	1	25,000	25,000
6	374207	CRACK TREATMENT	LS	1	28,700	28,700
7	031500	RELOCATE BUSINESS SIGN	EA	1	2,500	2,500
8	190185	SHOULDER BACKING	LF	1,480	8	11,840
9	013902	ASPHALT CONCRETE OVERSIDE DRAIN (CRS 306)	EA	2	4,444	8,888
10	013903	PLACE ASPHALT CONCRETE DIKE (CRS 212) (6")	LF	430	20	9,600
11	390132	HOT MIX ASPHALT (TYPE A)	TON	2,970	41.30 ⁵⁸	27 262,845
12	394076	PLACE HOT MIX ASPHALT DIKE (TYPE E)	LF	720	23	16,560
13	394090	PLACE HOT MIX ASPHALT (MISCELLANEOUS AREA)	SQYD	40	150	6,000
14	398200	COLD PLANE ASPHALT CONCRETE PAVEMENT	SQYD	11,250	6.25	70,312.50
15	510080	STRUCTURAL CONCRETE, APPROACH SLAB	CY	33	2,060	67,980
16	710100	ABANDON CULVERT	EA	1	10,700	10,700
17	723080	ROCK SLOPE PROTECTION (60 lb, Class II, METHOD B)	CY	7	1,632	11,424
18	017304	MINOR CONCRETE (CURB AND GUTTER) (CRS 200)	LF	500	70	35,000

REVISED PROPOSAL

ITEM No.	ITEM CODE	ITEM	UNIT	ESTIMATED QUANTITY	ITEM PRICE (IN FIGURES)	TOTAL (IN FIGURES)
BASE BID SCHEDULE - Park Lane, Ridgeview Drive and North Circle Drive and Village Center Drive Resurfacing Projects (continued)						
19	017316	MINOR CONCRETE (CURB RAMP) (CRS 403 - CASE B)	EA	2	6,000	12,000
20	731516	MINOR CONCRETE (DRIVEWAY)	SQFT	825	12	9,900
21	731521	MINOR CONCRETE (SIDEWALK)	SQFT	1,400	8	11,200
22	780433	PAINT CURB (2-COAT)	LF	130	3	390
23	803170	RELOCATE FENCE	LF	40	89	3,560
24	820410	SALVAGE ROADSIDE SIGN	EA	4	74	296
25	820840	ROADSIDE SIGN - ONE POST	EA	4	787	3,148
26	840515	THERMOPLASTIC PAVEMENT MARKING	SQFT	2,855	3.15	8,993.25
27	840656	PAINT TRAFFIC STRIPE (2-COAT)	LF	6,070	-74	4,491.80
28	846025	REMOVE PAINTED PAVEMENT MARKING	SQFT	71	7	497
29	010602	MISCELLANEOUS WORK (AS DIRECTED)	FA	1	60,000.00	60,000.00

BASE BID TOTAL: Seven hundred thirty three thousand three hundred twenty-five \$ 733,325.55
 ITEMS 1 - 29 hundred twenty-five "WORDS" dollars and fifty five cents

ALTERNATIVE BID SCHEDULE 1 - IDYLLWILD WATER DISTRICT

30	710212	ADJUST MANHOLE TO GRADE	EA	6	1,500	9,000
----	--------	-------------------------	----	---	-------	-------

ALT. BID 1 TOTAL: nine thousand dollars \$ 9,000
 ITEM 30 "WORDS"

PROJECT TOTAL: Seven hundred forty two thousand three hundred twenty-five \$ 742,325.55
 ITEMS 1 - 30 hundred twenty-five "WORDS" thousand dollars and fifty-five cents.

Bidder Data and Signature

Name of Bidder: Hardy & Harper, Inc.

Type of organization: S. Corporation

Person(s) authorized to sign for Bidder: Steve Kirschner - Vice President

Note:

If Bidder is a **Corporation**, state legal name of Corporation and also names of the president, vice-president, secretary, treasurer and manager thereof.

If Bidder is a **Co-Partnership**, state true name of firm and also names of all individual co-partners composing firm.

If Bidder is a sole proprietorship or an **Individual**, state first and last name(s) in full.

If Bid is signed by an agent other than an owner, partner or corporate officer, Bid shall be accompanied by a power-of-attorney.

Business Street Address: 32 Rancho Circle.
(Please include business address even if P.O. Box is used.)

Business City, State, Zip Code: Lake Forest, CA 92630

P.O. Box- Number: N/A

P.O. Box- City, State, Zip Code: N/A

Phone: (714) 444-1851

Facsimile: (714) 444-2801

E-mail: ablanchard@hardyandharper.com

Contractor's license number: 215952

License Classification(s): A, C-8 & C12

Expiration date: 12/31/19

Department of Industrial Relations Registration Number: 1000000076

Bidder Data and Signature (continued)

Accompanying this Bid is a certified check, cashier check or bid bond in an amount equal to at least ten (10) percent of the total bid for:

**Park Lane, Ridgeview Drive and North Circle Drive
Resurfacing Project
Village Center Drive to Village Center Drive; and
Village Center Drive Resurfacing Project
South Circle Drive to North Circle Drive
Community of Idyllwild
Project No. C1-0586, C8-0057**

By my signature on this Bid, I certify, under penalty of perjury under the laws of the State of California, that all the information on this form is true and correct.

IN WITNESS WHERE OF Bidder/Contractor executed this Bid as of the date set forth on page B1 of this Bid.

Signature:  _____

Name (printed): Steve Kirschner

Title: Vice President
"Contractor"

Subcontractor List

Bidder/Contractor submits the following complete list of each Subcontractor who will perform work, labor or render service in or about the construction in an amount in excess of 1/2 of 1% of the total bid or \$10,000 whichever is greater.

Check box on right side of row if any construction item, for the listed Subcontractor, is partial work. If partial work is to be performed within a certain construction item or trade, the Bidder/Contractor shall specify the portion(s) of the work to be performed by the different subcontractors or Bidder/Contractor will be subject to provisions of Public Contract Code Section 4106.

Name of Bidder (Prime/General Contractor): Hardy & Harper, Inc.

	Subcontractor Name	License Number	DIR Registration Number	Business Address (City, State)	Construction Item(s) [Item Number and Description]	Check if Partial Work
1.	Cal-Stripe	685387	100000 1100	Colton, CA	Striping, signs, markings 22, 24, 25, 26, 27, 28	<input type="checkbox"/>
2.	PRSE/Pavement Coatings Co.	303609	100000 3382	Jurupa Valley, CA	rental cold mill machine 24	<input checked="" type="checkbox"/>
3.	EBI Utilities Adjusting Inc.	932798	100000 4286	Corona, CA	Utility Adjusting 30	<input type="checkbox"/>
4.						<input type="checkbox"/>
5.						<input type="checkbox"/>
6.						<input type="checkbox"/>

Additional Subcontractor List(s) may be attached to the Bid.
(A copy of this form may be attached with additional Subcontractor information.)

Percent of work to be performed by Subcontractors: 5 %

Note: A minimum of 50% of the work is required to be performed by the prime/general Contractor.

Subcontractor List

Bidder/Contractor submits the following complete list of each Subcontractor who will perform work, labor or render service in or about the construction in an amount in excess of 1/2 of 1% of the total bid or \$10,000 whichever is greater.

Check box on right side of row if any construction item, for the listed Subcontractor, is partial work. If partial work is to be performed within a certain construction item or trade, the Bidder/Contractor shall specify the portion(s) of the work to be performed by the different subcontractors or Bidder/Contractor will be subject to provisions of Public Contract Code Section 4106.

Name of Bidder (Prime/General Contractor): Hardy & Harper, Inc.

	Subcontractor Name	License Number	DIR Registration Number	Business Address (City, State)	Construction Item(s) [Item Number and Description]	Check if Partial Work
1.						<input type="checkbox"/>
2.						<input type="checkbox"/>
3.						<input type="checkbox"/>
4.						<input type="checkbox"/>
5.						<input type="checkbox"/>
6.						<input type="checkbox"/>

Additional Subcontractor List(s) may be attached to the Bid.
(A copy of this form may be attached with additional Subcontractor information.)

Percent of work to be performed by Subcontractors: _____ %

Note: A minimum of 50% of the work is required to be performed by the prime/general Contractor.

Non-Collusion Declaration

To be executed by bidder and submitted with bid.
(Title 23 United States Code Section 112 and Public Contract Code Section 7106)

The undersigned declares:

I am the Vice President (Title) of Hardy & Harper, Inc. (Company),
the party making the foregoing bid.

The bid is not made in the interest of, or on behalf of, any undisclosed person, partnership, company, association, organization, or corporation. The bid is genuine and not collusive or sham. The bidder has not directly or indirectly induced or solicited any other bidder to put in a false or sham bid. The bidder has not directly or indirectly colluded, conspired, connived, or agreed with any bidder or anyone else to put in a sham bid, or that anyone shall refrain from bidding. The bidder has not in any manner, directly or indirectly, sought by agreement, communication, or conference with anyone to fix the bid price of the bidder or any other bidder, or to fix any overhead, profit, or cost element of the bid price, or of that of any other bidder.

All statements contained in the bid are true. The bidder has not, directly or indirectly, submitted his or her bid price of any breakdown thereof, or the contents thereof, or divulged information or data relative thereto, to any corporation, partnership, company, association, organization, bid depository, or to any member or agent thereof to effectuate a collusive or sham bid, and has not paid, and will not pay, any person or entity for such purpose.

Any person executing this declaration on behalf of a bidder that is a corporation, partnership, joint venture, limited liability company, limited liability partnership, or any other entity, hereby represents that he or she has full power to execute, and does execute, this declaration on behalf of the bidder.

I declare under penalty of perjury under the applicable laws that the foregoing is true and correct and that this declaration is executed on

August (Month) 6th (Day) of 2019 (Year),
at Lake Forest (City), California (State).

Signature of Declarant: 

Printed name of Declarant: Steve Kirschner

Name of Bidder (Company): Hardy & Harper, Inc.

Title or Office: Vice President

Note: Notarization of signature required.
 Check box if attachment is included.

CALIFORNIA ALL-PURPOSE ACKNOWLEDGMENT

CIVIL CODE § 1189

A notary public or other officer completing this certificate verifies only the identity of the individual who signed the document to which this certificate is attached, and not the truthfulness, accuracy, or validity of that document.

State of California)
County of Orange)

On August 6, 2019 before me, Ashlie Blanchard, Notary Public,
Date Here Insert Name and Title of the Officer

personally appeared Steve Kirschner
Name(s) of Signer(s)

who proved to me on the basis of satisfactory evidence to be the person(s) whose name(s) is/are subscribed to the within instrument and acknowledged to me that he/she/they executed the same in his/her/their authorized capacity(ies), and that by his/her/their signature(s) on the instrument the person(s), or the entity upon behalf of which the person(s) acted, executed the instrument.

I certify under PENALTY OF PERJURY under the laws of the State of California that the foregoing paragraph is true and correct.

WITNESS my hand and official seal.

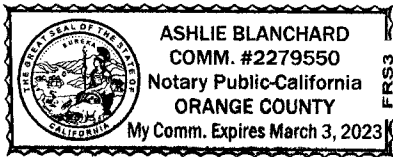

Signature Ashlie Blanchard
Signature of Notary Public

Place Notary Seal Above

OPTIONAL

Though this section is optional, completing this information can deter alteration of the document or fraudulent reattachment of this form to an unintended document.

Description of Attached Document

Title or Type of Document: _____ Document Date: _____

Number of Pages: _____ Signer(s) Other Than Named Above: _____

Capacity(ies) Claimed by Signer(s)

Signer's Name: _____

- Corporate Officer — Title(s): _____
- Partner — Limited General
- Individual Attorney in Fact
- Trustee Guardian or Conservator
- Other: _____

Signer Is Representing: _____

Signer's Name: _____

- Corporate Officer — Title(s): _____
- Partner — Limited General
- Individual Attorney in Fact
- Trustee Guardian or Conservator
- Other: _____

Signer Is Representing: _____

Iran Contracting Act
(Public Contract Code sections 2200-2208)

Prior to bidding on, submitting a proposal or executing a contract or renewal for a County of Riverside contract for goods or services of **\$1,000,000 or more**, a Contractor must either:

- a) Certify it is not on the current list of persons engaged in investment activities in Iran created by the California Department of General Services ("DGS") pursuant to Public Contract Code section 2203(b) and is not a financial institution extending twenty million dollars (\$20,000,000) or more in credit to another person, for 45 days or more, if that other person will use the credit to provide goods or services in the energy sector in Iran and is identified on the current list of persons engaged in investment activities in Iran created by DGS; or
- b) Demonstrate it has been exempted from the certification requirement for that solicitation or contract pursuant to Public Contract Code section 2203(c) or (d).

To comply with this requirement, please insert your Contractor or financial institution name and Federal ID Number (if available) and complete one of the options below. Please note: California law establishes penalties for providing false certifications, including civil penalties equal to the greater of \$250,000 or twice the amount of the contract for which the false certification was made; contract termination; and three-year ineligibility to bid on contracts. (Public Contract Code section 2205.)

Option #1 – Certification

I, the official named below, certify I am duly authorized to execute this certification on behalf of the vendor/financial institution identified below, and the vendor/financial institution identified below is **not** on the current list of persons engaged in investment activities in Iran created by DGS and is not a financial institution extending twenty million dollars (\$20,000,000) or more in credit to another person/vendor, for 45 days or more, if that other person/vendor will use the credit to provide goods or services in the energy sector in Iran and is identified on the current list of persons engaged in investment activities in Iran created by DGS.

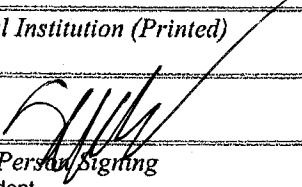
<i>Contractor Name/Financial Institution (Printed)</i> Hardy & Harper, Inc.		<i>Federal ID Number (or n/a)</i> 95-2251022
<i>By (Authorized Signature)</i> 		
<i>Printed Name and Title of Person Signing</i> Steve Kirschner - Vice President		
<i>Date Executed</i> 08/06/2019	<i>Executed in</i> Lake Forest, CA	

Option #2 – Exemption

Pursuant to Public Contract Code sections 2203(c) and (d), a public entity may permit a Contractor/financial institution engaged in investment activities in Iran, on a case-by-case basis, to be eligible for, or to bid on, submit a proposal for, or enters into or renews, a contract for goods and services.

If you have obtained an exemption from the certification requirement under the Iran Contracting Act, please fill out the information below, and **attach documentation demonstrating the exemption approval.**

<i>Contractor Name/Financial Institution (Printed)</i>		<i>Federal ID Number (or n/a)</i>
<i>By (Authorized Signature)</i>		
<i>Printed Name and Title of Person Signing</i>		
<i>Date Executed</i>	<i>Executed in</i>	

COPY

Bid Bond

Recitals:

1. Hardy & Harper, Inc. "Contractor", has submitted his/her Contractor's Proposal to County of Riverside, "County", for the construction of public work for Park Lane, Ridgeview Drive and North Circle Drive, Resurfacing Project, Village Center Drive to Village Center Drive; and Village Center Drive Resurfacing Project, South Circle Drive to North Circle Drive, Community of Idylwild, Project No. C1-0586, C8-0057 in accordance with a Notice Inviting Bids from the County.
2. Fidelity and Deposit Company of Maryland a Illinois corporation, hereafter called "Surety", is the surety of this bond.

Agreement:

We, Contractor as Principal and Surety as Surety, jointly and severally agree and state as follows:

1. The amount of the obligation of this bond is 10% of the amount of the Contractor's Proposal, including bid alternates, and inures to the benefit of County.
2. This Bond is exonerated by (1) County rejecting said Proposal or, in the alternate, (2) if said Proposal is accepted, Contractor executes the Contract and furnishes the Bonds as agreed to in its Proposal, otherwise it remains in full force and effect for the recovery of loss, damage and expense of County resulting from failure of Contractor to act as agreed to in its Proposal. Some types of possible loss, damage and expense are specified in the Contractor's Proposal.
3. Surety, for value received, stipulates and agrees that its obligations hereunder shall in no way be impaired or affected by any extension of time within which County may accept the Proposal and waives notice of any such extension.
4. This Bond is binding on our heirs, executors, administrators, successors and assigns.

Dated: August 6th, 2019

Signatures:

<u>Fidelity and Deposit Company of Maryland</u>	<u>Hardy & Harper, Inc.</u>
By: <u>Dwight Reilly</u>	By: <u>[Signature]</u>
Title: <u>Attorney in Fact</u> <u>"Surety"</u>	Title: <u>Steve Kirschner - Vice president</u> <u>"Contractor"</u>

STATE OF _____ } ss. SURETY'S ACKNOWLEDGEMENT
COUNTY _____ }
OF _____ }

On _____ before me, _____ personally appeared, _____ known to me, or proved to me on the basis of satisfactory evidence, to be the person whose name is subscribed to the within instrument and acknowledged to me that he/she executed the same in his/her authorized capacities, and that by his/her signature on the instrument the person, or the entity upon behalf of which the person acted, executed the instrument.

WITNESS my hand and official seal.

Signature of Notary Public
Notary Public (Seal)
Note: This Bond must be executed by both Contractor and Surety with corporate seal affixed. All signatures must be notarized. (Attach acknowledgements).

COPY

ACKNOWLEDGMENT

A notary public or other officer completing this certificate verifies only the identity of the individual who signed the document to which this certificate is attached, and not the truthfulness, accuracy, or validity of that document.

State of California
County of Orange

On 8/6/2019 before me, Melissa Ann Vaccaro, Notary Public
(insert name and title of the officer)

personally appeared Dwight Reilly
who proved to me on the basis of satisfactory evidence to be the person(s) whose name(s) is/are subscribed to the within instrument and acknowledged to me that he/she/they executed the same in his/her/their authorized capacity(ies), and that by his/her/their signature(s) on the instrument the person(s), or the entity upon behalf of which the person(s) acted, executed the instrument.

I certify under PENALTY OF PERJURY under the laws of the State of California that the foregoing paragraph is true and correct.

WITNESS my hand and official seal.

Signature Melissa Ann Vaccaro (Seal)
Melissa Ann Vaccaro

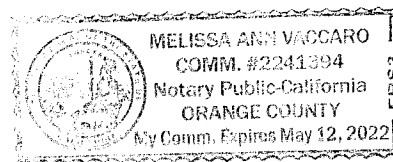

ZURICH AMERICAN INSURANCE COMPANY
COLONIAL AMERICAN CASUALTY AND SURETY COMPANY
FIDELITY AND DEPOSIT COMPANY OF MARYLAND
POWER OF ATTORNEY

COPY

KNOW ALL MEN BY THESE PRESENTS: That the ZURICH AMERICAN INSURANCE COMPANY, a corporation of the State of New York, the COLONIAL AMERICAN CASUALTY AND SURETY COMPANY, a corporation of the State of Illinois, and the FIDELITY AND DEPOSIT COMPANY OF MARYLAND a corporation of the State of Illinois (herein collectively called the "Companies"), by **Robert D. Murray, Vice President**, in pursuance of authority granted by Article V, Section 8, of the By-Laws of said Companies, which are set forth on the reverse side hereof and are hereby certified to be in full force and effect on the date hereof, do hereby nominate, constitute, and appoint, **Daniel HUCKABAY, Dwight REILLY, Arturo AYALA, Shaunna ROZELLE OSTROM and Frank MORONES, all of Orange, California, EACH**, its true and lawful agent and Attorney-in-Fact, to make, execute, seal and deliver, for, and on its behalf as surety, and as its act and deed: **any and all bonds and undertakings**, and the execution of such bonds or undertakings in pursuance of these presents, shall be as binding upon said Companies, as fully and amply, to all intents and purposes, as if they had been duly executed and acknowledged by the regularly elected officers of the ZURICH AMERICAN INSURANCE COMPANY at its office in New York, New York., the regularly elected officers of the COLONIAL AMERICAN CASUALTY AND SURETY COMPANY at its office in Owings Mills, Maryland., and the regularly elected officers of the FIDELITY AND DEPOSIT COMPANY OF MARYLAND at its office in Owings Mills, Maryland., in their own proper persons.

The said Vice President does hereby certify that the extract set forth on the reverse side hereof is a true copy of Article V, Section 8, of the By-Laws of said Companies, and is now in force.

IN WITNESS WHEREOF, the said Vice-President has hereunto subscribed his/her names and affixed the Corporate Seals of the said ZURICH AMERICAN INSURANCE COMPANY, COLONIAL AMERICAN CASUALTY AND SURETY COMPANY, and FIDELITY AND DEPOSIT COMPANY OF MARYLAND, this 24th day of June, A.D. 2019.



ATTEST:
ZURICH AMERICAN INSURANCE COMPANY
COLONIAL AMERICAN CASUALTY AND SURETY COMPANY
FIDELITY AND DEPOSIT COMPANY OF MARYLAND

By: *Robert D. Murray*
Vice President

By: *Dawn E. Brown*
Secretary

State of Maryland
County of Baltimore

On this 24th day of June, A.D. 2019, before the subscriber, a Notary Public of the State of Maryland, duly commissioned and qualified, **Robert D. Murray, Vice President and Dawn E. Brown, Secretary** of the Companies, to me personally known to be the individuals and officers described in and who executed the preceding instrument, and acknowledged the execution of same, and being by me duly sworn, deposed and saith, that he/she is the said officer of the Company aforesaid, and that the seals affixed to the preceding instrument are the Corporate Seals of said Companies, and that the said Corporate Seals and the signature as such officer were duly affixed and subscribed to the said instrument by the authority and direction of the said Corporations.

IN TESTIMONY WHEREOF, I have hereunto set my hand and affixed my Official Seal the day and year first above written.



Constance A. Dunn, Notary Public
My Commission Expires: July 9, 2023

EXTRACT FROM BY-LAWS OF THE COMPANIES

"Article V, Section 8, Attorneys-in-Fact. The Chief Executive Officer, the President, or any Executive Vice President or Vice President may, by written instrument under the attested corporate seal, appoint attorneys-in-fact with authority to execute bonds, policies, recognizances, stipulations, undertakings, or other like instruments on behalf of the Company, and may authorize any officer or any such attorney-in-fact to affix the corporate seal thereto; and may with or without cause modify or revoke any such appointment or authority at any time."

CERTIFICATE

I, the undersigned, Vice President of the ZURICH AMERICAN INSURANCE COMPANY, the COLONIAL AMERICAN CASUALTY AND SURETY COMPANY, and the FIDELITY AND DEPOSIT COMPANY OF MARYLAND, do hereby certify that the foregoing Power of Attorney is still in full force and effect on the date of this certificate; and I do further certify that Article V, Section 8, of the By-Laws of the Companies is still in force.

This Power of Attorney and Certificate may be signed by facsimile under and by authority of the following resolution of the Board of Directors of the ZURICH AMERICAN INSURANCE COMPANY at a meeting duly called and held on the 15th day of December 1998.

RESOLVED: "That the signature of the President or a Vice President and the attesting signature of a Secretary or an Assistant Secretary and the Seal of the Company may be affixed by facsimile on any Power of Attorney....Any such Power or any certificate thereof bearing such facsimile signature and seal shall be valid and binding on the Company."

This Power of Attorney and Certificate may be signed by facsimile under and by authority of the following resolution of the Board of Directors of the COLONIAL AMERICAN CASUALTY AND SURETY COMPANY at a meeting duly called and held on the 5th day of May, 1994, and the following resolution of the Board of Directors of the FIDELITY AND DEPOSIT COMPANY OF MARYLAND at a meeting duly called and held on the 10th day of May, 1990.

RESOLVED: "That the facsimile or mechanically reproduced seal of the company and facsimile or mechanically reproduced signature of any Vice-President, Secretary, or Assistant Secretary of the Company, whether made heretofore or hereafter, wherever appearing upon a certified copy of any power of attorney issued by the Company, shall be valid and binding upon the Company with the same force and effect as though manually affixed.

IN TESTIMONY WHEREOF, I have hereunto subscribed my name and affixed the corporate seals of the said Companies, this 6th day of August, 2019.



Michael C. Fay, Vice President

TO REPORT A CLAIM WITH REGARD TO A SURETY BOND, PLEASE SUBMIT A COMPLETE DESCRIPTION OF THE CLAIM INCLUDING THE PRINCIPAL ON THE BOND, THE BOND NUMBER, AND YOUR CONTACT INFORMATION TO:

Zurich Surety Claims
1299 Zurich Way
Schaumburg, IL 60196-1056
www.reportsfclaims@zurichna.com
800-626-4577

STATE OF CALIFORNIA
DEPARTMENT OF INSURANCE
SAN FRANCISCO

Amended

Certificate of Authority

THIS IS TO CERTIFY that, pursuant to the Insurance Code of the State of California,

Fidelity and Deposit Company of Maryland

of Illinois, organized under the laws of Illinois, subject to its Articles of Incorporation or other fundamental organizational documents, is hereby authorized to transact within this State, subject to all provisions of this Certificate, the following classes of insurance:

**Fire, Marine, Surety, Plate Glass, Liability, Workers' Compensation,
Boiler and Machinery, Burglary, Credit, Sprinkler, Team and Vehicle,
Automobile, Aircraft and Miscellaneous**

as such classes are now or may hereafter be defined in the Insurance Laws of the State of California.

THIS CERTIFICATE is expressly conditioned upon the holder hereof now and hereafter being in full compliance with all, and not in violation of any, of the applicable laws and lawful requirements made under authority of the laws of the State of California as long as such laws or requirements are in effect and applicable, and as such laws and requirements now are, or may hereafter be changed or amended.

IN WITNESS WHEREOF, effective as of the 12th day of March, 2019, I have set my hand and caused my official seal to be affixed this 12th day of March, 2019.

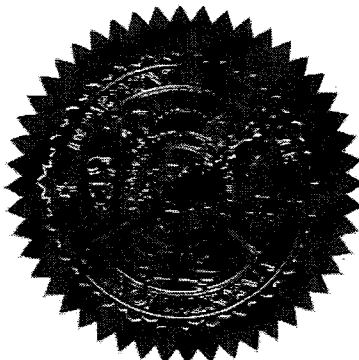

Ricardo Lara
Insurance Commissioner

Valerie Sarfaty
for Catalina Hayes-Bautista
Insurance Chief Deputy

By

NOTICE:

Qualification with the Secretary of State must be accomplished as required by the California Corporations Code promptly after issuance of this Certificate of Authority. Failure to do so will be a violation of Insurance Code section 701 and will be grounds for revoking this Certificate of Authority pursuant to the covenants made in the application therefor and the conditions contained herein.

COPY

CALIFORNIA ALL-PURPOSE ACKNOWLEDGMENT

CIVIL CODE § 1189

COPY

A notary public or other officer completing this certificate verifies only the identity of the individual who signed the document to which this certificate is attached, and not the truthfulness, accuracy, or validity of that document.

State of California)
County of Orange)

On August 6, 2019 before me, Ashlie Blanchard, Notary Public
Date Here Insert Name and Title of the Officer

personally appeared Steve Kirschner
Name(s) of Signer(s)

who proved to me on the basis of satisfactory evidence to be the person(s) whose name(s) is/are subscribed to the within instrument and acknowledged to me that he/she/they executed the same in his/her/their authorized capacity(ies), and that by his/her/their signature(s) on the instrument the person(s), or the entity upon behalf of which the person(s) acted, executed the instrument.

I certify under PENALTY OF PERJURY under the laws of the State of California that the foregoing paragraph is true and correct.

WITNESS my hand and official seal.

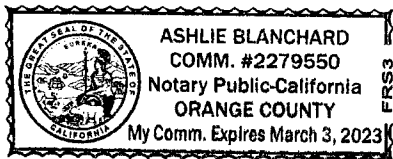

Signature Ashlie Blanchard
Signature of Notary Public

Place Notary Seal Above

OPTIONAL

Though this section is optional, completing this information can deter alteration of the document or fraudulent reattachment of this form to an unintended document.

Description of Attached Document

Title or Type of Document: _____ Document Date: _____
Number of Pages: _____ Signer(s) Other Than Named Above: _____

Capacity(ies) Claimed by Signer(s)

Signer's Name: _____
 Corporate Officer — Title(s): _____
 Partner — Limited General
 Individual Attorney in Fact
 Trustee Guardian or Conservator
 Other: _____
Signer Is Representing: _____

Signer's Name: _____
 Corporate Officer — Title(s): _____
 Partner — Limited General
 Individual Attorney in Fact
 Trustee Guardian or Conservator
 Other: _____
Signer Is Representing: _____



COPY

Company Profile

COMPANY PROFILE

Company Search

Company Information

Company Information

FIDELITY AND DEPOSIT COMPANY OF MARYLAND

Old Company Names

1299 ZURICH WAY
SCHAUMBURG, IL 60196
800-382-2150

Agent for Service

Old Company Names

Effective Date

Reference Information

NAIC Group List

Agent For Service

Lines of Business

Workers'

Melissa DeKoven
2710 Gateway Oaks Drive, Suite 150N
Sacramento CA 95833-3505

Compensation

Complaint and

Request for

Action/Appeals

Contact Information

Reference Information

Financial Statements PDF's

NAIC #:	39306
California Company ID #:	2479-4
Date Authorized in California:	01/01/1982
License Status:	UNLIMITED-NORMAL
Company Type:	Property & Casualty
State of Domicile:	ILLINOIS

Annual Statements

Quarterly Statements

Company Complaint

Company Performance & Comparison Data

Company Enforcement Action

Composite Complaints Studies

back to top

Additional Info

Find A Company Representative In Your Area

View Financial Disclaimer

NAIC Group List

NAIC Group #: 0212 ZURICH INS GRP

Lines Of Business

The company is authorized to transact business within these lines of insurance. For an explanation of any of these terms, please refer to the glossary.

- AIRCRAFT
- AUTOMOBILE
- BOILER AND MACHINERY
- BURGLARY
- CREDIT
- FIRE
- LIABILITY
- MARINE
- MISCELLANEOUS
- PLATE GLASS
- SPRINKLER
- SURETY
- TEAM AND VEHICLE
- WORKERS' COMPENSATION

back to top

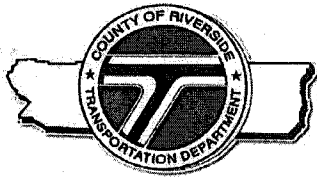

Patricia Romo, P.E.
Director of Transportation

COUNTY OF RIVERSIDE
TRANSPORTATION AND
LAND MANAGEMENT AGENCY

Mojahed Salama, P.E.
Deputy for Transportation/Capital Projects
Richard Lantis, P.L.S.
Deputy for Transportation/Planning and
Development

Transportation Department

ADDENDUM NUMBER 1

Dated July 26, 2019

to the
Specifications and Contract Documents
for the construction of

Park Lane, Ridgeview Drive and North Circle Drive
Resurfacing Project

Village Center Drive to Village Center Drive; and

Village Center Drive Resurfacing Project
South Circle Drive to North Circle Drive

Community of Idyllwild
Project No. C1-0586, C8-0057

Bids Due: Thursday, August 8, 2019; 2:00 p.m.
14th Street Transportation Annex
3525 14th Street; Riverside, CA 92501
(951) 955-6780

This Addendum is issued pursuant to the Instructions to Bidders, Item No. 8, of the Contract Documents for the reference project. This Addendum is issued as a supplement to the specification and special provisions for the referenced project. The revisions to the specifications shall become a part of the Contract Documents, and each bidder shall acknowledge receipt thereof on the Bid (Proposal). Bidders are directed to sign this addendum as acknowledged and attach the signed addendum to the contractor's submitted proposal.

Note: During the advertisement period of this project, this document and attachments (if any) are available upon request at the office of the Transportation Department, and are available as a free download at the Transportation Department's website:

<http://rctlma.org/trans/Contractors-Corner/Notices-Inviting-Bids>

MODIFICATIONS / CLARIFICATIONS TO SPECIAL PROVISIONS:

Item 1: Revised Engineering Estimate Range. Refer to the "Notice to Bidders" on page v of the bid documents. Delete the Engineering Estimate ranges found on page v of the "Notice to Bidders" and replace them with the following:

Engineering Estimate:	\$562,000 - \$655,000	(Base Bid Schedule)
	\$ 5,400 - \$ 6,300	(Alternative Bid Schedule)

Addendum No. 1

Park Lane, Ridgeview Drive and North Circle Drive Resurfacing Project, Village Center Drive to Village Center Drive, and; Village Center Drive Resurfacing Project, South Circle Drive to North Circle Drive

Community of Idyllwild, Project No. C1-0586, C8-0057

July 26, 2019

Page 2 of 5

Item 2: Revised Proposal. Refer to "Proposal" pages B2 and B3 of the bid documents. Delete and replace proposal (pages B2 and B3) with "Proposal (Revised)" attached herewith as **Attachment "A"**.

- a. The quantities for the following item are revised:
- Item 8, SHOULDER BACKING
 - Item 10, PLACE ASPHALT CONCRETE DIKE (CRS 212) (6")
 - Item 11, HOT MIX ASPHALT (TYPE A)
 - Item 13, PLACE HOT MIX ASPHALT (MISCELLANEOUS AREA)
 - Item 14, COLD PLANE ASPHALT CONCRETE PAVEMENT
 - Item 18, MINOR CONCRETE (CURB AND GUTTER) (CRS 200)
 - Item 20, MINOR CONCRETE (DRIVEWAY)
 - Item 21, MINOR CONCRETE (SIDEWALK)
 - Item 26, THERMOPLASTIC PAVEMENT MARKING
 - Item 27, PAINT TRAFFIC STRIPE (2-COAT)
 - Item 30, ADJUST MANHOLE TO GRADE

Item 3: Project Description. Refer to Section 00-1.01 "Project Description," of the special provisions (page 1). Delete the segment limits for Ridgeview Drive and North Circle Drive and replace them with the following limits:

Ridgeview Drive - State Route 243 to Village Center Drive
North Circle Drive - State Route 243 to Village Center Drive

Item 4: Encroachment Permit. Refer to Section 00-1.07 "Encroachment Permit," of the special provisions (page 3 and 4).

- Delete City of Riverside reference found in the third paragraph:
Contractor to submit Traffic Control plans and WPCP to Caltrans and ~~City of Riverside~~ for review and approval prior to issuance of Encroachment Permit.
- Delete the Payment paragraph on page 4 and replace it with the following Payment paragraph:

Payment:

If the Contractor pays any fees to Caltrans to obtain Encroachment Permit, then full compensation for the actual cost of the Encroachment Permit fees, as paid by the Contractor to Caltrans, shall be considered as included in the force account contract price for Miscellaneous Work (As directed). No markups will be allowed. All incidental costs incurred by the Contractor shall be considered as included in the various items of work and no compensation will be allowed therefor.

Addendum No. 1

Park Lane, Ridgeview Drive and North Circle Drive Resurfacing Project, Village Center Drive to Village Center Drive, and; Village Center Drive Resurfacing Project, South Circle Drive to North Circle Drive

Community of Idyllwild, Project No. C1-0586, C8-0057

July 26, 2019

Page 3 of 5

Item 5: Work Sequencing. Refer to Section 10-1.02 "Work Sequencing," of the special provisions (page 3 and 4). The following notices are added:

Repairs on State Route 74 and 243 near Idyllwild and Mountain Center

Due to flood repairs, State Route 243 between Idyllwild and Banning is expected to be closed during construction of the project; additionally, State Route 74 between Hemet and Mountain Center is also expected to be closed during construction of the project. At State Route 74, pilot cars are available to escort vehicles through the road closure only between the hours of 4:00 AM and 8:00 AM, and between 6:00 PM and 12:00 AM. Contractors shall consider these road closure and plan their work and material deliveries in accordance with these road restrictions.

Item 6: Public Outreach / Public Meetings. Refer to Section 12-5.01, "Traffic Control System/ Public Convenience/ Public Safety," subsection 12-5.04, "Public Outreach," of the special provisions (page 18).

The following provisions are added to subsection 12-5.04, "Public Outreach":

The Contractor shall be required to coordinate with Connect & Company PR for public outreach. As directed by the Resident Engineer, the Contractor shall be available to attend Public Meetings in order to inform the residents of the progress of the project, to provide information on lane closures, and to answer questions. The cost of attending these meetings shall be included in the cost of performing traffic control and no additional compensation will be provided therefor.

Connect & Company PR contact information will be made available to the awarded contractor during the pre-construction meeting.

Item 7: Clarification, Placement and Reconstruction of Asphalt Concrete Dike.

The contract unit bid price paid per linear foot for Place Asphalt Concrete Dike (CRS 212) 6" and Place Hot Mix Asphalt Dike (Type E) includes full compensation for placement of new asphalt concrete dike and for reconstruction of existing asphalt concrete dike as required.

Addendum No. 1

Park Lane, Ridgeview Drive and North Circle Drive Resurfacing Project, Village Center Drive to Village Center Drive, and; Village Center Drive Resurfacing Project, South Circle Drive to North Circle Drive

Community of Idyllwild, Project No. C1-0586, C8-0057

July 26, 2019

Page 4 of 5

MODIFICATIONS / CLARIFICATIONS TO THE PLANS

Item 8: Plan sheets added, revised. The following plan sheets are added or revised by Attachment "B" and are made a part hereby:

1. Plan sheet 5A of 7, L-3A, Layout (Added)
2. Plan sheet 7 of 7, PD-2, Pavement Delineation & Sign Plan (Revised)

ATTACHMENTS

A – Revised Proposal (2 pages)

B – Added / Revised Plans (2 Sheet)

Addendum No. 1

Park Lane, Ridgeview Drive and North Circle Drive Resurfacing Project, Village Center Drive to Village Center Drive, and; Village Center Drive Resurfacing Project, South Circle Drive to North Circle Drive

Community of Idyllwild, Project No. C1-0586, C8-0057

July 26, 2019

Page 5 of 5

This addendum has been prepared under the direction of the following registered Civil Engineer(s):

Recommended by:

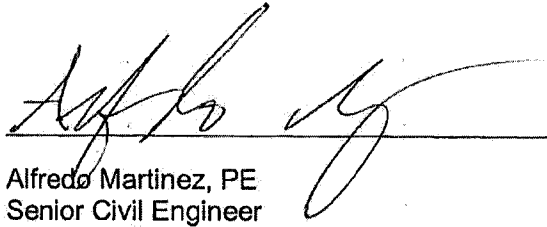

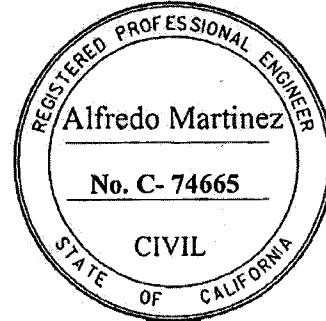
Alfredo Martinez, PE
Senior Civil Engineer



Concurrence:

Khalid Nasim, PE
Engineering Division Manager

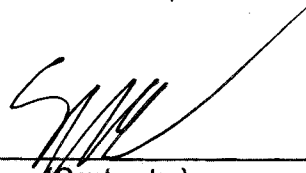
Acknowledged:

(Contractor)

Date:

7/26/19

Steve Kirschner - Vice President

JRJ: jrj:rr

Note: Refer to instruction to Bidders Item No. 8, "Addenda". Submission of all addendum pages and non-bidding document attachments of addendum are not necessary for Bid submittal. Submittal of this acknowledgement page is adequate for Bid reception. Bidders are reminded to list addendum number(s) received on the first page of the Bid form (Proposal).

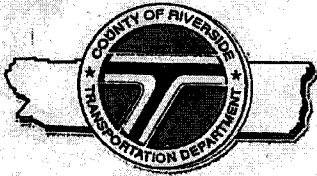

Patricia Romo, P.E.
Director of Transportation

COUNTY OF RIVERSIDE

TRANSPORTATION AND LAND MANAGEMENT AGENCY

Mojahed Salama, P.E.
Deputy for Transportation/Capital Projects
Richard Lantis, P.L.S.
Deputy for Transportation/Planning and
Development

Transportation Department

ADDENDUM NUMBER 2

Dated August 2, 2019

to the
Specifications and Contract Documents
for the construction of

Park Lane, Ridgeview Drive and North Circle Drive
Resurfacing Project

Village Center Drive to Village Center Drive; and

Village Center Drive Resurfacing Project
South Circle Drive to North Circle Drive

Community of Idyllwild
Project No. C1-0586, C8-0057

Bids Due: Thursday, August 8, 2019; 2:00 p.m.
14th Street Transportation Annex
3525 14th Street; Riverside, CA 92501
(951) 955-6780

This Addendum is issued pursuant to the Instructions to Bidders, Item No. 8, of the Contract Documents for the reference project. This Addendum is issued as a supplement to the specification and special provisions for the referenced project. The revisions to the specifications shall become a part of the Contract Documents, and each bidder shall acknowledge receipt thereof on the Bid (Proposal). Bidders are directed to sign this addendum as acknowledged and attach the signed addendum to the contractor's submitted proposal.

Note: During the advertisement period of this project, this document and attachments (if any) are available upon request at the office of the Transportation Department, and are available as a free download at the Transportation Department's website:

<http://rctlma.org/trans/Contractors-Corner/Notices-Inviting-Bids>

MODIFICATIONS / CLARIFICATIONS TO SPECIAL PROVISIONS:

Item 1: 00-1.03 Time of Completion. Refer to the section 00-1.03 Time of Completion on page 2 of Special Provisions. Following additional requirement added to this provision and made part thereof.

The Contractor must complete the project by October 25, 2019. The County anticipate to award this project on August 27, 2019.

Attention is directed to section 00-1.04 Liquidated Damages on page 2 of Special Provisions to be aware of consequences of project delay. Liquidated damages will be applicable for each and every calendar day delay after October 25, 2019.

Note: No work shall be allowed on Friday October 11, 2019 due to Annual Art Walk and Wine Tasting Festival.

Addendum No. 2

Park Lane, Ridgeview Drive and North Circle Drive Resurfacing Project, Village Center Drive to Village Center Drive, and; Village Center Drive Resurfacing Project, South Circle Drive to North Circle Drive
Community of Idyllwild, Project No. C1-0586, C8-0057

August 2, 2019

Page 3 of 3

This addendum has been prepared under the direction of the following registered Civil Engineer(s):

Recommended by:

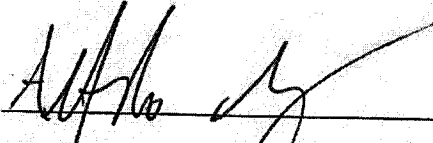

Alfredo Martinez, PE
Senior Civil Engineer

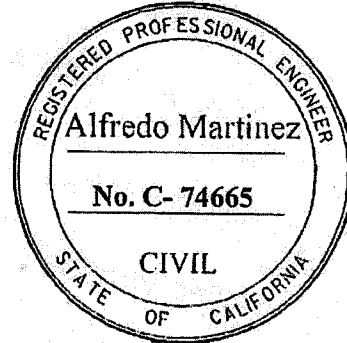

Concurrence:

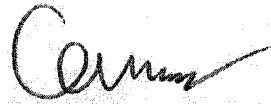

Khalid Nasim, PE
Engineering Division Manager

Acknowledged:



(Contractor)
Steve Kirschner-VP

Date:

8/2/19

JRJ: jrj:rr

Note: Refer to Instruction to Bidders Item No. 8, "Addenda". Submission of all addendum pages and non-bidding document attachments of addendum are not necessary for Bid submittal. Submittal of this acknowledgement page is adequate for Bid reception. Bidders are reminded to list addendum number(s) received on the first page of the Bid form (Proposal).

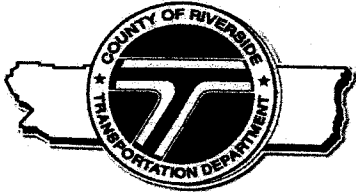

COUNTY OF RIVERSIDE
TRANSPORTATION AND
LAND MANAGEMENT AGENCY

Transportation Department

Patricia Romo, P.E.
Director of Transportation

Mojahed Salama, P.E.
Deputy for Transportation/Capital Projects
Richard Lantis, P.L.S.
Deputy for Transportation/Planning and
Development

DATE: July 23, 2019

Original Negative Declaration/Notice of
Determination was routed to County
Clerks for posting on.

TO: Kiyomi Moore, ACR Technician III

8/27/19 MB
Date Initial

FROM: *MZambon*
Mary Zambon, Environmental Division Manager

RE: **North Circle Drive/Park Lane/Ridgeview Drive & Village Center Drive
Resurfacing Project**
W.O.#ZC10586 & ZC80057, Task Code #Z1530

The Riverside County Transportation Department is requesting that you post the attached Notice of Exemption per County Implementing Resolution No. 82-213, Division 11, Section 205C. Attached you will find an authorization to bill by journal voucher in the amount of \$50.00 for your posting fee.

After posting, please return the document to Mail Stop #2136, Attention: Mohamed Eissa. If you have any questions, please contact me at (951) 955-1506.

Attachment

cc: file

AUG 27 2019 3.53

COUNTY OF RIVERSIDE

TRANSPORTATION AND LAND MANAGEMENT AGENCY

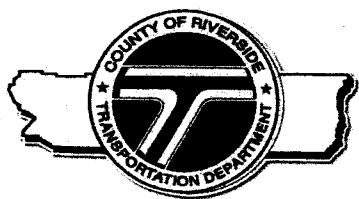

Patricia Romo, P.E.
Director of Transportation

Transportation Department NOTICE OF EXEMPTION

Mojahed Salama, P.E.
Deputy for Transportation/Capital Projects
Richard Lantis, P.L.S.
Deputy for Transportation/Planning and
Development

July 23, 2019

PROJECT TITLE: North Circle Drive/Park Lane/Ridgeview Drive & Village Center Drive
Resurfacing Project
Work Order #ZC10586 & ZC80057, Task Code #Z1530

PROJECT SPONSOR: Riverside County Transportation Department

PROJECT LOCATION: Community of Idyllwild

SUPERVISORIAL DISTRICT: 3rd

PROJECT DESCRIPTION: The Riverside County Transportation Department (RCTD) proposes to resurface 300 feet of Park Lane from Ridgeview Drive to North Circle Drive and approximately 0.3 miles of Village Center Drive from South Circle Drive to North Circle Drive. Park Lane is 41 feet wide with curb and gutter along the roadway, and is classified as a local road in the County of Riverside General Plan. Village Center Drive ranges from 24-32 feet wide with dike at various segments of the roadway, and is classified as a local road in the County of Riverside General Plan. Additionally, 700 feet of Ridgeview Drive from State Highway 243 to Village Center Drive and 300 feet of North Circle Drive from State Highway 243 to Village Center Drive will be resurfaced with the same treatment. The proposed project will include the following:

- Removal of roadway width and placing Hot Mixed Asphalt (HMA)
- Construction of curb ramp and asphalt concrete dike
- Reconstruction of asphalt concrete walkway, dike, sidewalk, driveway, overside drain, and curb/gutter
- Placement of safety edge and shoulder backing
- Utility adjustments
- Removal/installation of traffic striping, pavement markers and reflectors, and signs

ENVIRONMENTAL ANALYSIS:

The proposed project will be constructed within existing County right-of-way. Temporary construction easements will not be required for the proposed improvements.

This project is subject to compliance with the Western Riverside County Multiple Species Habitat Conservation Plan (MSHCP). In accordance with Section 7.1 of the Western Riverside County MSHCP, necessary operation and maintenance along existing roadways are considered a covered activity outside cell criteria areas. This project is not within cell criteria areas and is considered to be a safety improvement project under operation and maintenance, therefore it is a covered activity under the Western Riverside County MSHCP.

If tree and/or vegetation removal takes place during the migratory bird breeding season (March 1 – September 1), a preconstruction nesting survey will be conducted pursuant to the Migratory Bird Treaty Act (MBTA).

The Riverside County Transportation Department has found that the above-described project is exempt from the provisions of the California Environmental Quality Act (CEQA), based on the following:

Section 15301 (c) – Existing Facilities – The project proposes to resurface Park Lane, Village Center Drive and Ridgeview Drive, as well as a small segment of North Circle Drive. Additionally, the project proposes necessary safety improvements such as reconstruction of walkway, sidewalk, driveway, curb and gutter, and placement of safety edge on shoulder backing. The proposed project is exempt from CEQA under Section 15301 (c) because the resurfacing of the roadways and necessary safety improvements do not create additional automobiles lanes and involve negligible or no expansion of existing or former use of the existing roadway and associated facilities.

By: Mohamed Eissa, Assistant Transportation Planner

Signed: Mary Zambon

Mary Zambon, Environmental Division Manager

RIVERSIDE COUNTY CLERK & RECORDER

**AUTHORIZATION
TO BILL
BY JOURNAL VOUCHER**

-TO BE FILLED IN BY SUBMITTING AGENCY-
537280-20000-3130500000 ZC10586C Z1530

AUTHORIZATION NUMBER: W.O.#ZC10586C, Task Code Z1530

AMOUNT: \$50.00

DATE: July 23, 2019

AGENCY: Riverside County Transportation Department

THIS AUTHORIZES THE COUNTY CLERK & RECORDER TO ISSUE A VOUCHER FOR PAYMENT OF ALL FILING AND HANDLING FEES FOR THE ACCOMPANYING DOCUMENT(S).

NUMBER OF DOCUMENTS INCLUDED: One (1)

AUTHORIZED BY: Mary Zambon, Environmental Division Manager

Signature: Mary Zambon

PRESENTED BY: Mohamed Eissa

-TO BE FILLED IN BY COUNTY CLERK-

ACCEPTED BY: -

DATE: -

RECEIPT # (S) -

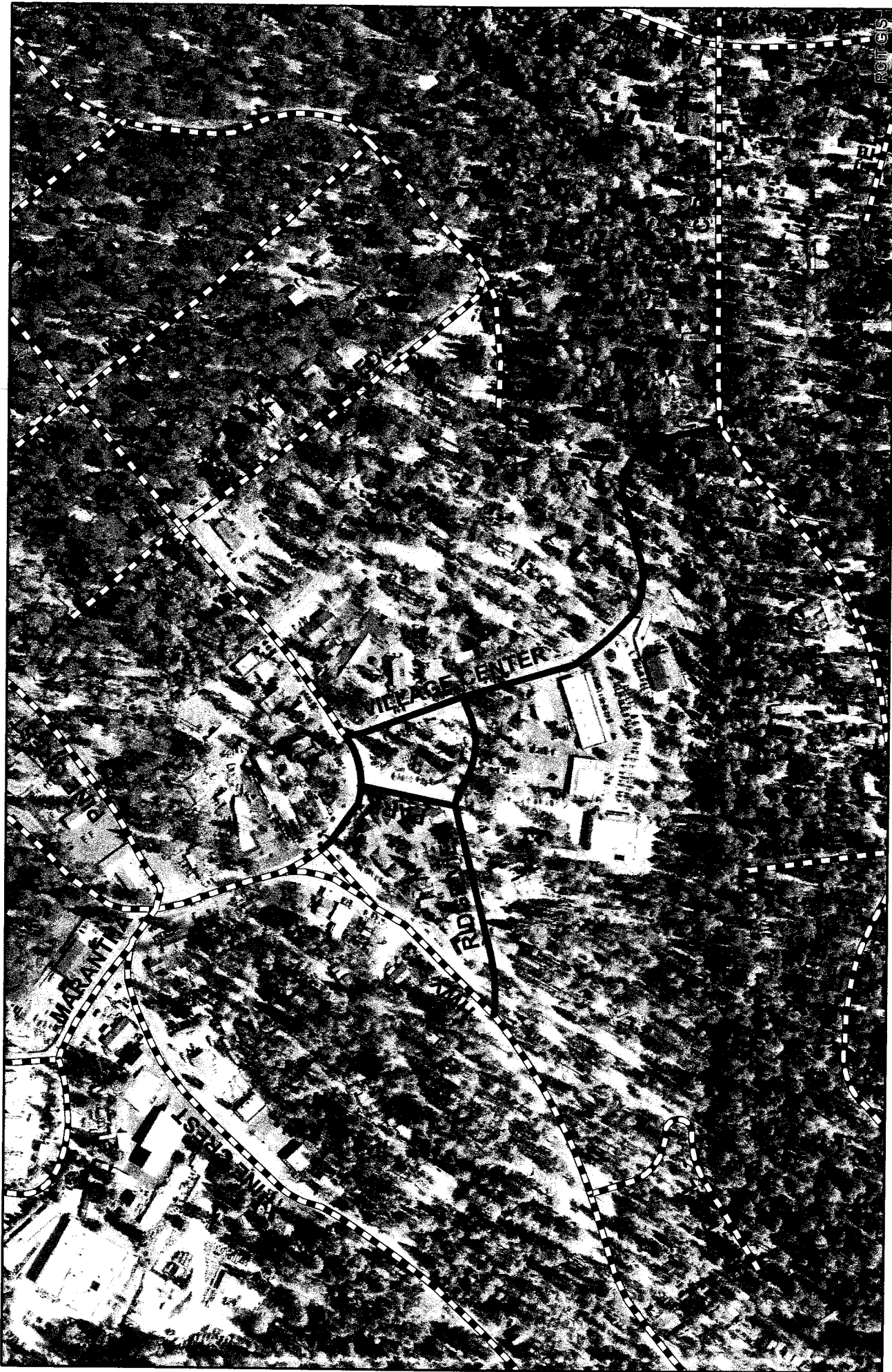

— Project Limits

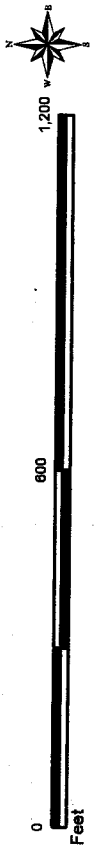

Park Lane & Village Resurfacing Exhibit



Riverside County
Transportation Department

CLERK'S COPY

to Riverside County Clerk of the Board, Stop 1010

Post Office Box 1147, Riverside, Ca 92502-1147

Thank you.

Riverside County Contract No. 19-08-005

Contract

THIS CONTRACT is entered into at Riverside, California as of the date set forth below is between County of Riverside hereafter called "County" and **Hardy & Harper, Inc.**, hereafter called "Contractor".

WITNESSETH

Recitals:

1. Contractor has submitted to County his Contractor's Proposal for the construction of County Project, **Park Lane, Ridgeview Drive and North Circle Drive, Resurfacing Project, Village Center Drive to Village Center Drive; and Village Center Drive Resurfacing Project, South Circle Drive to North Circle Drive, Community of Idyllwild, Project No. C1-0586, C8-0057,** in strict accordance with the Contract Documents identified below and County has accepted said Proposal.
2. Contractor states that he has reexamined his Contractor's Proposal and found it to be correct, has ascertained that his subcontractors are properly licensed and possess the requisite skill and forces, has reexamined the site and Contract Documents and is of the opinion that he can presently do the work in accordance with the Contract Documents for the money set forth in his Proposal to be paid as provided in the Contract Documents.

Agreement:

It is agreed by the parties as follows:

1. Contract Documents

The entire Contract consists of the following: (a) The Construction Contract, (b) The Notice to Bidders. (c) The Instruction to Bidders, (d) The Bid, (e) The Bid Bond, (f) The Payment Bond, (g) The Performance Bond, (h) The General Conditions, (i) The Special Provisions, (j) The Standard Specifications of the State of California Department of Transportation edition of **2015** as modified in other portions of the Contract Documents and as amended by the State of California Department of Transportation, (k) The Standard Plans of the Department of Transportation identified on the plans or in the Special Provisions, (l) The Plans, (m) Addenda **(2)** , (n) The Determination of Prevailing Wage Rates for Public Works, (o) Any Change Orders issued, and (p) Any additional or supplemental specifications, notice, instructions and drawings issued in accordance with the provisions of the Contract Documents. All of said Documents presently in existence are by this reference incorporated herein with like effect as if here set forth in full and upon the proper issuance of other documents they shall likewise be deemed incorporated. The Bid Bond is exonerated upon execution of this Contract and the Payment Bond and Performance Bond.

2. The Work

Contractor shall do all tasks necessary to construct the work generally described in Recital No. 1 in accordance with the Contract Documents.

3. Prosecution, Progress and Liquidated Damages

Attention is directed to the provisions in Section 8-1.04, "Start of Job Site Activities", Section 8-1.05, "Time", and in Section 8-1.10 "Liquidated Damages" of the Standard Specifications and these Special Provisions.

Standard Specification Section 8-1.04B, "Standard Start" is modified to read as follows:

The Contractor shall begin work within fifteen (15) calendar days, or as revised in the Special Provisions, of the date stated within the written "Notice to Proceed".

The Contractor shall notify the Engineer, in writing, of the Contractor's intent to begin work at least 72 hours before work is begun. If the project has more than one (1) location of work, Contractor shall submit a separate notice for each location. The notice shall be delivered to the Transportation Department's Construction Engineer and shall specify the date the Contractor intends to start at said location.

Should the Contractor begin work in advance of receiving a written "Notice to Proceed", any work performed by the Contractor in advance of the date stated in the "Notice to Proceed" shall be considered as having been done by the Contractor at his own risk and as a volunteer and subject to the following:

- A. The Contractor shall, on commencing operations, take all precautions required for public safety and shall observe all the provisions in the Specifications and the Special Provisions.
- B. All work done according to the Contract, prior to the issuance of the "Notice to Proceed", will be considered authorized work and will be paid for as provided in the contract.
- C. The Contractor shall not be entitled to any additional compensation or an extension of time for any delay, hindrance or interference caused by or attributable to commencement of work prior to the issuance of the "Notice to Proceed".

4. Compensation

Contractor shall be paid in the manner set forth in the Contract Documents the amount of his Proposal as accepted by County, the above rates, subject to additions and deductions as provided in the Contract Documents. Said Proposal is on file in the Office of the Clerk of the Board of Supervisors of County.

**Park Lane, Ridgeview Drive and North Circle Drive
Resurfacing Project**
Village Center Drive to Village Center Drive; and
Village Center Drive Resurfacing Project
South Circle Drive to North Circle Drive
Community of Idyllwild
Project No. C1-0586, C8-0057

Contract

ITEM No.	ITEM CODE	ITEM	UNIT	ESTIMATED QUANTITY	ITEM PRICE (IN FIGURES)	TOTAL (IN FIGURES)
BASE BID SCHEDULE: Park Lane, Ridgeview Drive and North Circle Drive; and Village Center Drive Resurfacing Projects						
1	100100	DEVELOP WATER SUPPLY	LS	1	5,000.00	5,000.00
2	120100	TRAFFIC CONTROL SYSTEM	LS	1	30,000.00	30,000.00
3	130200	PREPARE WATER POLLUTION CONTROL PROGRAM	LS	1	7,500.00	7,500.00
4	170103	CLEARING AND GRUBBING	LS	1	10,000.00	10,000.00
5	066012	DUST ABATEMENT	LS	1	25,000.00	25,000.00
6	374207	CRACK TREATMENT	LS	1	28,700.00	28,700.00
7	031500	RELOCATE BUSINESS SIGN	EA	1	2,500.00	2,500.00
8	190185	SHOULDER BACKING	LF	1,480	8.00	11,840.00
9	013902	ASPHALT CONCRETE OVERSIDE DRAIN (CRS 306)	EA	2	4,444.00	8,888.00
10	013903	PLACE ASPHALT CONCRETE DIKE (CRS 212) (6")	LF	430	20.00	8,600.00
11	390132	HOT MIX ASPHALT (TYPE A)	TON	2,970	88.50	262,845.00
12	394076	PLACE HOT MIX ASPHALT DIKE (TYPE E)	LF	720	23.00	16,560.00
13	394090	PLACE HOT MIX ASPHALT (MISCELLANEOUS AREA)	SQYD	40	150.00	6,000.00
14	398200	COLD PLANE ASPHALT CONCRETE PAVEMENT	SQYD	11,250	6.25	70,312.50
15	510080	STRUCTURAL CONCRETE, APPROACH SLAB	CY	33	2,060.00	67,980.00
16	710100	ABANDON CULVERT	EA	1	10,700.00	10,700.00
17	723080	ROCK SLOPE PROTECTION (60 lb, Class II, METHOD B)	CY	7	1,632.00	11,424.00
18	017304	MINOR CONCRETE (CURB AND GUTTER) (CRS 200)	LF	500	70.00	35,000.00
19	017316	MINOR CONCRETE (CURB RAMP) (CRS 403 - CASE B)	EA	2	6,000.00	12,000.00

Contract (Continued)

ITEM No.	ITEM CODE	ITEM	UNIT	ESTIMATED QUANTITY	ITEM PRICE (IN FIGURES)	TOTAL (IN FIGURES)
BASE BID SCHEDULE: Park Lane, Ridgeview Drive and North Circle Drive; and Village Center Drive Resurfacing Projects						
20	731516	MINOR CONCRETE (DRIVEWAY)	SQFT	825	12.00	9,900.00
21	731521	MINOR CONCRETE (SIDEWALK)	SQFT	1,400	8.00	11,200.00
22	780433	PAINT CURB (2-COAT)	LF	130	3.00	390.00
23	803170	RELOCATE FENCE	LF	40	89.00	3,560.00
24	820410	SALVAGE ROADSIDE SIGN	EA	4	74.00	296.00
25	820840	ROADSIDE SIGN - ONE POST	EA	4	787.00	3,148.00
26	840515	THERMOPLASTIC PAVEMENT MARKING	SQFT	2,855	3.15	8,993.25
27	840656	PAINT TRAFFIC STRIPE (2-COAT)	LF	6,070	0.74	4,491.80
28	846025	REMOVE PAINTED PAVEMENT MARKING	SQFT	71	7.00	497.00
29	010602	MISCELLANEOUS WORK (AS DIRECTED)	FA	1	60,000.00	60,000.00

BASE BID SCHEDULE: Seven hundred thirty three thousand, three hundred twenty five dollars and fifty five cents **\$733,325.55**
 ITEMS 1 - 29 "WORDS"

ALTERNATIVE BID SCH. 1 - Idyllwild Water District

30	710212	ADJUST MANHOLE TO GRADE	EA	6	1,500.00	9,000.00
----	--------	-------------------------	----	---	----------	----------

ALT. BID SCHEDULE 1: Nine thousand dollars and zero cents **\$ 9,000.00**
 ITEM 30 "WORDS"

PROJECT TOTAL: Seven hundred forty two thousand, three hundred twenty five dollars and fifty five cents **\$742,325.55**
 ITEMS 1- 30 "WORDS"

**Park Lane, Ridgeview Drive and North Circle Drive
Resurfacing Project
Village Center Drive to Village Center Drive; and
Village Center Drive Resurfacing Project
South Circle Drive to North Circle Drive
Community of Idyllwild
Project No. C1-0586, C8-0057**

IN WITNESS WHEREOF the parties hereto have executed this Contract as of the date set forth below.

COUNTY OF RIVERSIDE

HARDY & HARPER, INC.

BY: 
KEVIN JEFFRIES
Chairman, Board of Supervisors

BY: 
Steve Kirschner

DATED: AUG 27 2019

TITLE: Vice President
(If Corporation, affix Seal)

ATTEST:

ATTEST:

Kecia Harper ~~them~~, Clerk of the Board

Kristen Paulino

BY: 
Deputy

TITLE: Secretary

Licensed in accordance with an act providing for the registration of Contractors,

FORM APPROVED COUNTY COUNSEL
BY  8/28/19 DATE
KRISTINE BELL-VALDEZ

License No.: 215952

Federal Employer Identification Number:

95-2251022

Department of Industrial Relations Registration Number:

1000000076

BY _____
"County"

"Corporation"
(Seal)

MINUTES OF BOARD OF DIRECTORS
HELD ON NOVEMBER 15, 2005

The Board of Directors met this date pursuant to the president's request for a special board meeting. Notice was waived. All directors being present in the office of the corporation the meeting was called to order by the president and;

The Secretary then presented the waiver of notice which was agreed to by all directors and entered in the minutes.

The following directors were present being all the acting directors:

Fred T. Maas, Jr.
Daniel Maas
Steven M. Kirschner
Kristen S. Paulino

The President, Fred T. Maas Jr., then called the board's attention to the purpose of the meeting which was to authorize Daniel Maas as a director and CEO, Steven M. Kirschner as a director and Vice President, and Kristen S. Paulino as a director and secretary of the corporation to enter into contracts, bids and other documents on behalf of the corporation.

On motion unanimously carried the following resolution was adopted:

Daniel Maas, Steven M. Kirschner, and Kristen S. Paulino are authorized to sign contracts, bids, credit applications and necessary documents on behalf of the corporation to bind the corporation as he and the president of the corporation agree.

There being no further business, the meeting was adjourned.

DATED: November 15, 2005



FRED T. MAAS, JR., President



KRISTEN S. PAULINO, Secretary

Performance Bond

Bond No. 7661427
Premium: \$4,035.00

Recitals:

1. Hardy & Harper, Inc. (Contractor) has entered into a Contract with COUNTY OF RIVERSIDE (County) for construction of public work known as Park Lane, Ridgeview Drive and North Circle Drive, Resurfacing Project, Village Center Drive to Village Center Drive; and Village Center Drive Resurfacing Project, South Circle Drive to North Circle Drive, Community of Idyllwild, Project No. C1-0586, C8-0057.
2. Fidelity and Deposit Company of Maryland, a _____ Illinois _____ corporation (Surety), is the Surety under this Bond.

Agreement:

We, Contractor as Principal and Surety as Surety, jointly and severally agree, state, and are bound unto County, as obligee, as follows:

1. The amount of the obligation of this Bond is 100% of the estimated contract price for the Project of \$742,325.55 (Seven hundred forty two thousand, three hundred twenty five dollars and fifty five cents) and inures to the benefit of County.
2. This Bond is exonerated by Contractor doing all things to be kept and performed by it in strict conformance with the Contract Documents for this project, otherwise it remains in full force and effect for the recovery of loss, damage and expense of County resulting from failure of Contractor to so act. All of said Contract Documents are incorporated herein.
3. This obligation is binding on our successors and assigns.
4. For value received, Surety stipulates and agrees that no change, time extension, prepayment to Contractor, alteration or addition to the terms and requirements of the Contract Documents or the work to be performed thereunder shall affect its obligations hereunder and waives notice as to such matters, except the total contract price cannot be increased by more than 10% without approval of Surety.

THIS BOND is executed as of _____ August 20th, 2019 _____

By _____
Hardy & Harper, Inc.
Steve Kirschner - V.P.
By _____
Kristen Paulino - Secretary

By _____
Fidelity and Deposit Company of Maryland
Type Name Dwight Reilly, Attorney-in-Fact

Its Attorney in Fact
"Surety"

Title _____

"Contractor"

(Corporate Seal)

(Corporate Seal)

NOTE: This Bond must be executed by both parties with corporate seal affixed. All signatures must be acknowledged. (Attach acknowledgements).

CALIFORNIA ALL-PURPOSE ACKNOWLEDGMENT

CIVIL CODE § 1189

A notary public or other officer completing this certificate verifies only the identity of the individual who signed the document to which this certificate is attached, and not the truthfulness, accuracy, or validity of that document.

State of California)
County of Orange)

On August 20, 2019 before me, Tina Pham, Notary Public
Date Here Insert Name and Title of the Officer
personally appeared Steve Kirschner & Kristen Paulino
Name(s) of Signer(s)

who proved to me on the basis of satisfactory evidence to be the person(s) whose name(s) ~~is~~/are subscribed to the within instrument and acknowledged to me that ~~he~~/she/they executed the same in ~~his~~/her/their authorized capacity(ies), and that by ~~his~~/her/their signature(s) on the instrument the person(s), or the entity upon behalf of which the person(s) acted, executed the instrument.

I certify under PENALTY OF PERJURY under the laws of the State of California that the foregoing paragraph is true and correct.

WITNESS my hand and official seal.



Signature *[Handwritten Signature]*
Signature of Notary Public

Place Notary Seal Above

OPTIONAL

Though this section is optional, completing this information can deter alteration of the document or fraudulent reattachment of this form to an unintended document.

Description of Attached Document

Title or Type of Document: Performance Bond Document Date: August 20, 2019
Number of Pages: 1 Signer(s) Other Than Named Above: Dwight Reilly

Capacity(ies) Claimed by Signer(s)

Signer's Name: Steve Kirschner
 Corporate Officer — Title(s): Vice President
 Partner — Limited General
 Individual Attorney in Fact
 Trustee Guardian or Conservator
 Other: _____
Signer Is Representing: Hardy & Harper, Inc.

Signer's Name: Kristen Paulino
 Corporate Officer — Title(s): Secretary
 Partner — Limited General
 Individual Attorney in Fact
 Trustee Guardian or Conservator
 Other: _____
Signer Is Representing: Hardy & Harper, Inc.

ACKNOWLEDGMENT

A notary public or other officer completing this certificate verifies only the identity of the individual who signed the document to which this certificate is attached, and not the truthfulness, accuracy, or validity of that document.

State of California
County of Orange)

On 8/20/2019 before me, Melissa Ann Vaccaro, Notary Public
(insert name and title of the officer)

personally appeared Dwight Reilly
who proved to me on the basis of satisfactory evidence to be the person(s) whose name(s) is/are subscribed to the within instrument and acknowledged to me that he/she/they executed the same in his/her/their authorized capacity(ies), and that by his/her/their signature(s) on the instrument the person(s), or the entity upon behalf of which the person(s) acted, executed the instrument.

I certify under PENALTY OF PERJURY under the laws of the State of California that the foregoing paragraph is true and correct.

WITNESS my hand and official seal.

Signature Melissa Ann Vaccaro (Seal)
Melissa Ann Vaccaro



**ZURICH AMERICAN INSURANCE COMPANY
COLONIAL AMERICAN CASUALTY AND SURETY COMPANY
FIDELITY AND DEPOSIT COMPANY OF MARYLAND
POWER OF ATTORNEY**

KNOW ALL MEN BY THESE PRESENTS: That the ZURICH AMERICAN INSURANCE COMPANY, a corporation of the State of New York, the COLONIAL AMERICAN CASUALTY AND SURETY COMPANY, a corporation of the State of Illinois, and the FIDELITY AND DEPOSIT COMPANY OF MARYLAND a corporation of the State of Illinois (herein collectively called the "Companies"), by **Robert D. Murray, Vice President**, in pursuance of authority granted by Article V, Section 8, of the By-Laws of said Companies, which are set forth on the reverse side hereof and are hereby certified to be in full force and effect on the date hereof, do hereby nominate, constitute, and appoint, **Daniel HUCKABAY, Dwight REILLY, Arturo AYALA, Shaunna ROZELLE OSTROM and Frank MORONES, all of Orange, California, EACH**, its true and lawful agent and Attorney-in-Fact, to make, execute, seal and deliver, for, and on its behalf as surety, and as its act and deed: **any and all bonds and undertakings**, and the execution of such bonds or undertakings in pursuance of these presents, shall be as binding upon said Companies, as fully and amply, to all intents and purposes, as if they had been duly executed and acknowledged by the regularly elected officers of the ZURICH AMERICAN INSURANCE COMPANY at its office in New York, New York., the regularly elected officers of the COLONIAL AMERICAN CASUALTY AND SURETY COMPANY at its office in Owings Mills, Maryland., and the regularly elected officers of the FIDELITY AND DEPOSIT COMPANY OF MARYLAND at its office in Owings Mills, Maryland., in their own proper persons.

The said Vice President does hereby certify that the extract set forth on the reverse side hereof is a true copy of Article V, Section 8, of the By-Laws of said Companies, and is now in force.

IN WITNESS WHEREOF, the said Vice-President has hereunto subscribed his/her names and affixed the Corporate Seals of the said ZURICH AMERICAN INSURANCE COMPANY, COLONIAL AMERICAN CASUALTY AND SURETY COMPANY, and FIDELITY AND DEPOSIT COMPANY OF MARYLAND, this 24th day of June, A.D. 2019.



ATTEST:
ZURICH AMERICAN INSURANCE COMPANY
COLONIAL AMERICAN CASUALTY AND SURETY COMPANY
FIDELITY AND DEPOSIT COMPANY OF MARYLAND

By: *Robert D. Murray*
Vice President

By: *Dawn E. Brown*
Secretary

**State of Maryland
County of Baltimore**

On this 24th day of June, A.D. 2019, before the subscriber, a Notary Public of the State of Maryland, duly commissioned and qualified, **Robert D. Murray, Vice President and Dawn E. Brown, Secretary** of the Companies, to me personally known to be the individuals and officers described in and who executed the preceding instrument, and acknowledged the execution of same, and being by me duly sworn, depose and saith, that he/she is the said officer of the Company aforesaid, and that the seals affixed to the preceding instrument are the Corporate Seals of said Companies, and that the said Corporate Seals and the signature as such officer were duly affixed and subscribed to the said instrument by the authority and direction of the said Corporations.

IN TESTIMONY WHEREOF, I have hereunto set my hand and affixed my Official Seal the day and year first above written.



Constance A. Dunn, Notary Public
My Commission Expires: July 9, 2023



Company Profile

Company Search

→ Company Information

Old Company Names

Agent for Service

Reference Information

NAIC Group List

Lines of Business

Workers'

Compensation

Complaint and

Request for

Action/Appeals

Contact Information

Financial Statements PDF's

Annual Statements

Quarterly Statements

Company Complaint

Company Performance & Comparison Data

Company Enforcement Action

Composite Complaints Studies

Additional Info

Find A Company Representative In Your Area

View Financial Disclaimer

COMPANY PROFILE

Company Information

FIDELITY AND DEPOSIT COMPANY OF MARYLAND

1299 ZURICH WAY
SCHAUMBURG, IL 60196
800-382-2150

Old Company Names

Effective Date

Agent For Service

Melissa DeKoven
2710 Gateway Oaks Drive, Suite 150N
Sacramento CA 95833-3505

Reference Information

NAIC #:	39306
California Company ID #:	2479-4
Date Authorized in California:	01/01/1982
License Status:	UNLIMITED-NORMAL
Company Type:	Property & Casualty
State of Domicile:	ILLINOIS

[back to top](#)

NAIC Group List

NAIC Group #: [0212](#) ZURICH INS GRP

Lines Of Business

The company is authorized to transact business within these lines of insurance. For an explanation of any of these terms, please refer to the [glossary](#).

AIRCRAFT
AUTOMOBILE
BOILER AND MACHINERY
BURGLARY
CREDIT
FIRE
LIABILITY
MARINE
MISCELLANEOUS
PLATE GLASS
SPRINKLER
SURETY
TEAM AND VEHICLE
WORKERS' COMPENSATION

[back to top](#)

Bond No. 7661427

Payment Bond

(Public Works - Civil Code §9550 et seq.)

The makers of this Bond are Hardy & Harper, Inc., as Principal and Original Contractor and Fidelity and Deposit Company of Maryland, a corporation, authorized to issue Surety Bonds in California, as Surety, and this Bond is issued in conjunction with that certain public works contract to be executed between Principal and COUNTY OF RIVERSIDE a public entity, as Owner, for \$742,325.55 (Seven hundred forty two thousand, three hundred twenty five dollars and fifty five cents), the total amount payable. The amount of this bond is one hundred percent (100%) of said sum. Said contract is for public work generally consisting of Park Lane, Ridgeview Drive and North Circle Drive, Resurfacing Project, Village Center Drive to Village Center Drive; and Village Center Drive Resurfacing Project, South Circle Drive to North Circle Drive, Community of Idyllwild, Project No. CI-0586, C8-0057.

The beneficiaries of this Bond are as is stated in 9554 of the Civil Code and requirements and conditions of this Bond are as is set forth in 9554, 9558, 9560 and 9564 of said code. Without notice, Surety consents to extension of time for performance, change in requirements, amount of compensation, or prepayment under said contract.

Dated: August 20th, 2019

Hardy & Harper, Inc.
Original Contractor – Principal

Fidelity and Deposit Company of Maryland
Surety

By 
Steve Kirschner

By 
Dwight Reilly, Attorney-in-Fact
Its Attorney In Fact

Title Vice President
(If corporation, affix seal)

(Corporate Seal)

(Corporate Seal)

STATE
OF _____
COUNTY
OF _____

} ss. SURETY'S ACKNOWLEDGEMENT

On _____ before me, _____ personally appeared, _____, known to me, or proved to me on the basis of satisfactory evidence, to be the person whose name is subscribed to the within instrument and acknowledged to me that he executed the same in his authorized capacities, and that by his signature on the instrument the person, or the entity upon behalf of which the person acted, executed the instrument.

WITNESS my hand and official seal.

Signature of Notary Public

Notary Public (Seal)

NOTE: This Bond must be executed by both parties with corporate seal affixed. All signatures must be acknowledged. (Attach acknowledgements).

CALIFORNIA ALL-PURPOSE ACKNOWLEDGMENT

CIVIL CODE § 1189

A notary public or other officer completing this certificate verifies only the identity of the individual who signed the document to which this certificate is attached, and not the truthfulness, accuracy, or validity of that document.

State of California)
County of Orange)

On August 20, 2019 before me, Tina Pham, Notary Public
Date Here Insert Name and Title of the Officer

personally appeared Steve Kirschner
Name(s) of Signer(s)

who proved to me on the basis of satisfactory evidence to be the person(s) whose name(s) is/~~are~~ subscribed to the within instrument and acknowledged to me that he/~~she/they~~ executed the same in his/~~her/their~~ authorized capacity(ies), and that by his/~~her/their~~ signature(s) on the instrument the person(s), or the entity upon behalf of which the person(s) acted, executed the instrument.

I certify under PENALTY OF PERJURY under the laws of the State of California that the foregoing paragraph is true and correct.

WITNESS my hand and official seal.



Signature *Tina Pham*
Signature of Notary Public

Place Notary Seal Above

OPTIONAL

Though this section is optional, completing this information can deter alteration of the document or fraudulent reattachment of this form to an unintended document.

Description of Attached Document

Title or Type of Document: Payment Bond Document Date: August 20, 2019
Number of Pages: 1 Signer(s) Other Than Named Above: Dwight Reilly

Capacity(ies) Claimed by Signer(s)

Signer's Name: Steve Kirschner
 Corporate Officer — Title(s): Vice President
 Partner — Limited General
 Individual Attorney in Fact
 Trustee Guardian or Conservator
 Other: _____
Signer Is Representing: Hardy & Harper, Inc.

Signer's Name: _____
 Corporate Officer — Title(s): _____
 Partner — Limited General
 Individual Attorney in Fact
 Trustee Guardian or Conservator
 Other: _____
Signer Is Representing: _____

ACKNOWLEDGMENT

A notary public or other officer completing this certificate verifies only the identity of the individual who signed the document to which this certificate is attached, and not the truthfulness, accuracy, or validity of that document.

State of California
County of Orange)

On 8/20/2019 before me, Melissa Ann Vaccaro, Notary Public
(insert name and title of the officer)

personally appeared Dwight Reilly
who proved to me on the basis of satisfactory evidence to be the person(s) whose name(s) is/are subscribed to the within instrument and acknowledged to me that he/she/they executed the same in his/her/their authorized capacity(ies), and that by his/her/their signature(s) on the instrument the person(s), or the entity upon behalf of which the person(s) acted, executed the instrument.

I certify under PENALTY OF PERJURY under the laws of the State of California that the foregoing paragraph is true and correct.

WITNESS my hand and official seal.

Signature Melissa Ann Vaccaro (Seal)
Melissa Ann Vaccaro



**ZURICH AMERICAN INSURANCE COMPANY
COLONIAL AMERICAN CASUALTY AND SURETY COMPANY
FIDELITY AND DEPOSIT COMPANY OF MARYLAND
POWER OF ATTORNEY**

KNOW ALL MEN BY THESE PRESENTS: That the ZURICH AMERICAN INSURANCE COMPANY, a corporation of the State of New York, the COLONIAL AMERICAN CASUALTY AND SURETY COMPANY, a corporation of the State of Illinois, and the FIDELITY AND DEPOSIT COMPANY OF MARYLAND a corporation of the State of Illinois (herein collectively called the "Companies"), by **Robert D. Murray, Vice President**, in pursuance of authority granted by Article V, Section 8, of the By-Laws of said Companies, which are set forth on the reverse side hereof and are hereby certified to be in full force and effect on the date hereof, do hereby nominate, constitute, and appoint, **Daniel HUCKABAY, Dwight REILLY, Arturo AYALA, Shaunna ROZELLE OSTROM and Frank MORONES, all of Orange, California, EACH**, its true and lawful agent and Attorney-in-Fact, to make, execute, seal and deliver, for, and on its behalf as surety, and as its act and deed: **any and all bonds and undertakings**, and the execution of such bonds or undertakings in pursuance of these presents, shall be as binding upon said Companies, as fully and amply, to all intents and purposes, as if they had been duly executed and acknowledged by the regularly elected officers of the ZURICH AMERICAN INSURANCE COMPANY at its office in New York, New York., the regularly elected officers of the COLONIAL AMERICAN CASUALTY AND SURETY COMPANY at its office in Owings Mills, Maryland., and the regularly elected officers of the FIDELITY AND DEPOSIT COMPANY OF MARYLAND at its office in Owings Mills, Maryland., in their own proper persons.

The said Vice President does hereby certify that the extract set forth on the reverse side hereof is a true copy of Article V, Section 8, of the By-Laws of said Companies, and is now in force.

IN WITNESS WHEREOF, the said Vice-President has hereunto subscribed his/her names and affixed the Corporate Seals of the said ZURICH AMERICAN INSURANCE COMPANY, COLONIAL AMERICAN CASUALTY AND SURETY COMPANY, and FIDELITY AND DEPOSIT COMPANY OF MARYLAND, this 24th day of June, A.D. 2019.



ATTEST:
ZURICH AMERICAN INSURANCE COMPANY
COLONIAL AMERICAN CASUALTY AND SURETY COMPANY
FIDELITY AND DEPOSIT COMPANY OF MARYLAND

By: *Robert D. Murray*
Vice President

By: *Dawn E. Brown*
Secretary

**State of Maryland
County of Baltimore**

On this 24th day of June, A.D. 2019, before the subscriber, a Notary Public of the State of Maryland, duly commissioned and qualified, **Robert D. Murray, Vice President and Dawn E. Brown, Secretary** of the Companies, to me personally known to be the individuals and officers described in and who executed the preceding instrument, and acknowledged the execution of same, and being by me duly sworn, depose and saith, that he/she is the said officer of the Company aforesaid, and that the seals affixed to the preceding instrument are the Corporate Seals of said Companies, and that the said Corporate Seals and the signature as such officer were duly affixed and subscribed to the said instrument by the authority and direction of the said Corporations.

IN TESTIMONY WHEREOF, I have hereunto set my hand and affixed my Official Seal the day and year first above written.



Constance A. Dunn, Notary Public
My Commission Expires: July 9, 2023



Company Profile

Company Search

→ Company Information

Old Company Names

Agent for Service

Reference Information

NAIC Group List

Lines of Business

Workers'

Compensation

Complaint and

Request for

Action/Appeals

Contact Information

Financial Statements PDF's

Annual Statements

Quarterly Statements

Company Complaint

Company

Performance &

Comparison Data

Company

Enforcement Action

Composite

Complaints Studies

Additional Info

Find A Company Representative In Your Area

View Financial Disclaimer

COMPANY PROFILE

Company Information

FIDELITY AND DEPOSIT COMPANY OF MARYLAND

1299 ZURICH WAY
SCHAUMBURG, IL 60196
800-382-2150

Old Company Names

Effective Date

Agent For Service

Melissa DeKoven
2710 Gateway Oaks Drive, Suite 150N
Sacramento CA 95833-3505

Reference Information

NAIC #:	39306
California Company ID #:	2479-4
Date Authorized in California:	01/01/1982
License Status:	UNLIMITED-NORMAL
Company Type:	Property & Casualty
State of Domicile:	ILLINOIS

[back to top](#)

NAIC Group List

NAIC Group #: [0212](#) ZURICH INS GRP

Lines Of Business

The company is authorized to transact business within these lines of insurance. For an explanation of any of these terms, please refer to the [glossary](#).

AIRCRAFT
AUTOMOBILE
BOILER AND MACHINERY
BURGLARY
CREDIT
FIRE
LIABILITY
MARINE
MISCELLANEOUS
PLATE GLASS
SPRINKLER
SURETY
TEAM AND VEHICLE
WORKERS' COMPENSATION

[back to top](#)

AGENCY CUSTOMER ID: _____

LOC #: _____



ADDITIONAL REMARKS SCHEDULE

Page 1 of 1

AGENCY Newport Beach-Alliant Insurance Services, Inc.		NAMED INSURED Hardy & Harper, Inc. Maas Equipment, LLC 32 Rancho Circle Lake Forest CA 92630	
POLICY NUMBER		EFFECTIVE DATE:	
CARRIER	NAIC CODE		

ADDITIONAL REMARKS

**THIS ADDITIONAL REMARKS FORM IS A SCHEDULE TO ACORD FORM,
FORM NUMBER: 25 FORM TITLE: CERTIFICATE OF LIABILITY INSURANCE**

appointed officials, employees, agents and representatives;
State of California, Department of Transportation, its elected officials, its officers, directors, employees and agents; Idyllwild Water District, its elected officials, its officers, directors, employees and agents per the attached endorsements.

THIS ENDORSEMENT CHANGES THE POLICY. PLEASE READ IT CAREFULLY.

**ADDITIONAL INSURED – OWNERS, LESSEES OR
CONTRACTORS – SCHEDULED PERSON OR
ORGANIZATION**

This endorsement modifies insurance provided under the following:

COMMERCIAL GENERAL LIABILITY COVERAGE PART

SCHEDULE

Name Of Additional Insured Person(s) Or Organization(s)	Location(s) Of Covered Operations
As Required By Written Contract, Fully Executed Prior To The Named Insured's Work	As Required By Written Contract, Fully Executed Prior To The Named Insured's Work
Information required to complete this Schedule, if not shown above, will be shown in the Declarations.	

A. Section II – Who Is An Insured is amended to include as an additional insured the person(s) or organization(s) shown in the Schedule, but only with respect to liability for "bodily injury", "property damage" or "personal and advertising injury" caused, in whole or in part, by:

1. Your acts or omissions; or
2. The acts or omissions of those acting on your behalf;

in the performance of your ongoing operations for the additional insured(s) at the location(s) designated above.

However:

1. The insurance afforded to such additional insured only applies to the extent permitted by law; and
2. If coverage provided to the additional insured is required by a contract or agreement, the insurance afforded to such additional insured will not be broader than that which you are required by the contract or agreement to provide for such additional insured.

B. With respect to the insurance afforded to these additional insureds, the following additional exclusions apply:

This insurance does not apply to "bodily injury" or "property damage" occurring after:

1. All work, including materials, parts or equipment furnished in connection with such work, on the project (other than service, maintenance or repairs) to be performed by or on behalf of the additional insured(s) at the location of the covered operations has been completed; or
2. That portion of "your work" out of which the injury or damage arises has been put to its intended use by any person or organization other than another contractor or subcontractor engaged in performing operations for a principal as a part of the same project.

Philip S. King

C. With respect to the insurance afforded to these additional insureds, the following is added to **Section III – Limits Of Insurance:**

If coverage provided to the additional insured is required by a contract or agreement, the most we will pay on behalf of the additional insured is the amount of insurance:

1. Required by the contract or agreement; or

2. Available under the applicable Limits of Insurance shown in the Declarations;
whichever is less.

This endorsement shall not increase the applicable Limits of Insurance shown in the Declarations.

Philip J. Ryan

THIS ENDORSEMENT CHANGES THE POLICY. PLEASE READ IT CAREFULLY.

ADDITIONAL INSURED – OWNERS, LESSEES OR CONTRACTORS – COMPLETED OPERATIONS

This endorsement modifies insurance provided under the following:

COMMERCIAL GENERAL LIABILITY COVERAGE PART
PRODUCTS/COMPLETED OPERATIONS LIABILITY COVERAGE PART

SCHEDULE

Name Of Additional Insured Person(s) Or Organization(s)	Location And Description Of Completed Operations
As Required By Written Contract, Fully Executed Prior To The Named Insured's Work	As Required By Written Contract, Fully Executed Prior To The Named Insured's Work
Information required to complete this Schedule, if not shown above, will be shown in the Declarations.	

A. Section II – Who Is An Insured is amended to include as an additional insured the person(s) or organization(s) shown in the Schedule, but only with respect to liability for "bodily injury" or "property damage" caused, in whole or in part, by "your work" at the location designated and described in the Schedule of this endorsement performed for that additional insured and included in the "products-completed operations hazard".

However:

1. The insurance afforded to such additional insured only applies to the extent permitted by law; and
2. If coverage provided to the additional insured is required by a contract or agreement, the insurance afforded to such additional insured will not be broader than that which you are required by the contract or agreement to provide for such additional insured.

B. With respect to the insurance afforded to these additional insureds, the following is added to Section III – Limits Of Insurance:

If coverage provided to the additional insured is required by a contract or agreement, the most we will pay on behalf of the additional insured is the amount of insurance:

1. Required by the contract or agreement; or
2. Available under the applicable Limits of Insurance shown in the Declarations;

whichever is less.

This endorsement shall not increase the applicable Limits of Insurance shown in the Declarations.



THIS ENDORSEMENT CHANGES THE POLICY. PLEASE READ IT CAREFULLY.

**PRIMARY INSURANCE FOR
SCHEDULED ADDITIONAL INSURED**

This endorsement modifies insurance provided under the following:

COMMERCIAL GENERAL LIABILITY COVERAGE PART

SCHEDULE

Additional Insured:

Location Of Covered Operations:

WHERE REQUIRED BY WRITTEN CONTRACT.

ALL LOCATIONS

(If no entry appears above, information required to complete this endorsement will be shown in the Declarations as applicable to this endorsement.)

With respect only to the Additional Insured and at the Location Of Covered Operations shown in the Schedule, the following is added to **SECTION IV – COMMERCIAL GENERAL LIABILITY CONDITIONS**, Paragraph 4. **Other Insurance** and supersedes any provision to the contrary:

Primary And Noncontributory Insurance

This insurance is primary to and will not seek contribution from any other insurance available to the Additional Insured with respect to the Location Of Covered Operations shown in the Schedule under this policy provided that:

- (1) The Additional Insured is a named insured under such other insurance; and
- (2) You have agreed in writing in a contract or agreement that this insurance would be primary and would not seek contribution from any other insurance available to the Additional Insured.

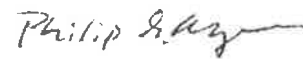

- b. Those statements are based upon representations you made to us; and
- c. We have issued this policy in reliance upon your representations.

7. Separation Of Insureds

Except with respect to the Limits of Insurance, and any rights or duties specifically assigned in this Coverage Part to the first Named Insured, this insurance applies:

- a. As if each Named Insured were the only Named Insured; and
- b. Separately to each insured against whom claim is made or "suit" is brought.

8. Transfer Or Waiver Of Rights Of Recovery Against Others To Us

We will waive the right of recovery we would otherwise have had against another person or organization, for loss to which this insurance applies, provided the insured has waived their rights of recovery against such person or organization in a contract or agreement that is executed before such loss.

To the extent that the insured's rights to recover all or part of any payment made under this Coverage Part have not been waived, those rights are transferred to us. The insured must do nothing after loss to impair them. At our request, the insured will bring "suit" or transfer those rights to us and help us enforce them.

This condition does not apply to Coverage C.

9. When We Do Not Renew

If we decide not to renew this Coverage Part, we will mail or deliver to the first Named Insured shown in the Declarations written notice of the nonrenewal not less than 30 days before the expiration date.

If notice is mailed, proof of mailing will be sufficient proof of notice.

SECTION V – DEFINITIONS

- 1. "Advertisement" means an electronic, oral, written or other notice, about goods, products or services, designed for the specific purpose of attracting the general public or a specific market segment to use such goods, products or services.

"Advertisement" does not include any e-mail address, Internet domain name or other electronic address or metalanguage.

- 2. "Advertising injury" means injury, other than "bodily injury", "property damage" or "personal injury", sustained by a person or organization and caused by an offense of infringing, in that particular part of your "advertisement" about your goods, products or services, upon their:

- a. Copyrighted "advertisement"; or
- b. Registered collective mark, registered service mark or other registered trademarked name, slogan, symbol or title.

- 3. "Asbestos" means asbestos in any form, including its presence or use in any alloy, by-product, compound or other material or waste. Waste includes materials to be recycled, reconditioned or reclaimed.

- 4. "Auto" means:

- a. A land motor vehicle, trailer or semitrailer designed for travel on public roads, including any attached machinery or equipment; or
- b. Any other land vehicle that is subject to a compulsory or financial responsibility law or other motor vehicle insurance law where it is licensed or principally garaged.

However, "auto" does not include "mobile equipment".

- 5. "Bodily injury" means physical:

- a. Injury;
- b. Sickness; or
- c. Disease;

sustained by a person, including resulting death, humiliation, mental anguish, mental injury or shock at any time. All such loss shall be deemed to occur at the time of the physical injury, sickness or disease that caused it.

- 6. "Coverage territory" means:

- a. The United States of America (including its territories and possessions), Puerto Rico and Canada;
- b. International waters or airspace, but only if the injury or damage occurs in the course of travel or transportation between any places included in Paragraph a. above; or
- c. All other parts of the world if the injury or damage arises out of:

- (1) Goods or products made or sold by you in the territory described in Paragraph a. above;
- (2) The activities of a person whose home is in the territory described in Paragraph a. above, but is away for a short time on your business; or
- (3) "Advertising injury" or "personal injury" offenses that take place through the Internet or similar electronic means of communication

Philip J. Ray

THIS ENDORSEMENT CHANGES THE POLICY. PLEASE READ IT CAREFULLY.

DESIGNATED CONSTRUCTION PROJECT(S) GENERAL AGGREGATE LIMIT

This endorsement modifies insurance provided under the following:

COMMERCIAL GENERAL LIABILITY COVERAGE PART

SCHEDULE

Designated Construction Project(s): where required by written contract

Information required to complete this Schedule, if not shown above, will be shown in the Declarations.

- A. For all sums which the insured becomes legally obligated to pay as damages caused by "occurrences" under Section I – Coverage A, and for all medical expenses caused by accidents under Section I – Coverage C, which can be attributed only to ongoing operations at a single designated construction project shown in the Schedule above:
 - 1. A separate Designated Construction Project General Aggregate Limit applies to each designated construction project, and that limit is equal to the amount of the General Aggregate Limit shown in the Declarations.
 - 2. The Designated Construction Project General Aggregate Limit is the most we will pay for the sum of all damages under Coverage A, except damages because of "bodily injury" or "property damage" included in the "products-completed operations hazard", and for medical expenses under Coverage C regardless of the number of:
 - a. Insureds;
 - b. Claims made or "suits" brought; or
 - c. Persons or organizations making claims or bringing "suits".
 - 3. Any payments made under Coverage A for damages or under Coverage C for medical expenses shall reduce the Designated Construction Project General Aggregate Limit for that designated construction project. Such payments shall not reduce the General Aggregate Limit shown in the Declarations nor shall they reduce any other Designated Construction Project General Aggregate Limit for any other designated construction project shown in the Schedule above.
 - 4. The limits shown in the Declarations for Each Occurrence, Damage To Premises Rented To You and Medical Expense continue to apply. However, instead of being subject to the General Aggregate Limit shown in the Declarations, such limits will be subject to the applicable Designated Construction Project General Aggregate Limit.

Philip S. Arz

- B.** For all sums which the insured becomes legally obligated to pay as damages caused by "occurrences" under Section I – Coverage **A**, and for all medical expenses caused by accidents under Section I – Coverage **C**, which cannot be attributed only to ongoing operations at a single designated construction project shown in the Schedule above:
1. Any payments made under Coverage **A** for damages or under Coverage **C** for medical expenses shall reduce the amount available under the General Aggregate Limit or the Products-completed Operations Aggregate Limit, whichever is applicable; and
 2. Such payments shall not reduce any Designated Construction Project General Aggregate Limit.
- C.** When coverage for liability arising out of the "products-completed operations hazard" is provided, any payments for damages because of "bodily injury" or "property damage" included in the "products-completed operations hazard" will reduce the Products-completed Operations Aggregate Limit, and not reduce the General Aggregate Limit nor the Designated Construction Project General Aggregate Limit.
- D.** If the applicable designated construction project has been abandoned, delayed, or abandoned and then restarted, or if the authorized contracting parties deviate from plans, blueprints, designs, specifications or timetables, the project will still be deemed to be the same construction project.
- E.** The provisions of Section III – Limits Of Insurance not otherwise modified by this endorsement shall continue to apply as stipulated.

Philip S. Azy



Coverage Extension Endorsement

Policy No.	Eff. Date of Pol.	Exp. Date of Pol.	Eff. Date of End.	Producer No.	Add'l. Prem.	Return Prem.
BAP0000000	10-1-2018	10-1-2019				

THIS ENDORSEMENT CHANGES THE POLICY. PLEASE READ IT CAREFULLY.

This endorsement modifies insurance provided under the:

**Business Auto Coverage Form
Motor Carrier Coverage Form**

A. Amended Who Is An Insured

1. The following is added to the **Who Is An Insured** Provision in **Section II – Covered Autos Liability Coverage**:

The following are also "insureds":

- a. Any "employee" of yours is an "insured" while using a covered "auto" you don't own, hire or borrow for acts performed within the scope of employment by you. Any "employee" of yours is also an "insured" while operating an "auto" hired or rented under a contract or agreement in an "employee's" name, with your permission, while performing duties related to the conduct of your business.
- b. Anyone volunteering services to you is an "insured" while using a covered "auto" you don't own, hire or borrow to transport your clients or other persons in activities necessary to your business.
- c. Anyone else who furnishes an "auto" referenced in Paragraphs A.1.a. and A.1.b. in this endorsement.
- d. Where and to the extent permitted by law, any person(s) or organization(s) where required by written contract or written agreement with you executed prior to any "accident", including those person(s) or organization(s) directing your work pursuant to such written contract or written agreement with you, provided the "accident" arises out of operations governed by such contract or agreement and only up to the limits required in the written contract or written agreement, or the Limits of Insurance shown in the Declarations, whichever is less.

2. The following is added to the **Other Insurance** Condition in the Business Auto Coverage Form and the **Other Insurance – Primary and Excess Insurance Provisions** Condition in the Motor Carrier Coverage Form:

Coverage for any person(s) or organization(s), where required by written contract or written agreement with you executed prior to any "accident", will apply on a primary and non-contributory basis and any insurance maintained by the additional "insured" will apply on an excess basis. However, in no event will this coverage extend beyond the terms and conditions of the Coverage Form.

B. Amendment – Supplementary Payments

Paragraphs a.(2) and a.(4) of the **Coverage Extensions** Provision in **Section II – Covered Autos Liability Coverage** are replaced by the following:

- (2) Up to \$5,000 for the cost of bail bonds (including bonds for related traffic law violations) required because of an "accident" we cover. We do not have to furnish these bonds.
- (4) All reasonable expenses incurred by the "insured" at our request, including actual loss of earnings up to \$500 a day because of time off from work.

Philip J. Kelly

C. Fellow Employee Coverage

The **Fellow Employee Exclusion** contained in **Section II – Covered Autos Liability Coverage** does not apply.

D. Driver Safety Program Liability and Physical Damage Coverage

1. The following is added to the **Racing Exclusion** in **Section II – Covered Autos Liability Coverage**:

This exclusion does not apply to covered "autos" participating in a driver safety program event, such as, but not limited to, auto or truck rodeos and other auto or truck agility demonstrations.

2. The following is added to Paragraph 2. in the Exclusions of **Section III – Physical Damage Coverage** of the **Business Auto Coverage Form** and Paragraph 2.b. in the Exclusions of **Section IV – Physical Damage Coverage** of the **Motor Carrier Coverage Form**:

This exclusion does not apply to covered "autos" participating in a driver safety program event, such as, but not limited to, auto or truck rodeos and other auto or truck agility demonstrations.

E. Lease or Loan Gap Coverage

The following is added to the **Coverage Provision** of the **Physical Damage Coverage Section**:

Lease Or Loan Gap Coverage

In the event of a total "loss" to a covered "auto", we will pay any unpaid amount due on the lease or loan for a covered "auto", less:

- a. Any amount paid under the **Physical Damage Coverage Section** of the Coverage Form, and
- b. Any:
 - (1) Overdue lease or loan payments at the time of the "loss";
 - (2) Financial penalties imposed under a lease for excessive use, abnormal wear and tear or high mileage;
 - (3) Security deposits not returned by the lessor;
 - (4) Costs for extended warranties, credit life insurance, health, accident or disability insurance purchased with the loan or lease; and
 - (5) Carry-over balances from previous leases or loans.

F. Towing and Labor

Paragraph **A.2.** of the **Physical Damage Coverage Section** is replaced by the following:

We will pay up to \$75 for towing and labor costs incurred each time a covered "auto" of the private passenger type is disabled. However, the labor must be performed at the place of disablement.

G. Extended Glass Coverage

The following is added to Paragraph **A.3.a.** of the **Physical Damage Coverage Section**:

If glass must be replaced, the deductible shown in the Declarations will apply. However, if glass can be repaired and is actually repaired rather than replaced, the deductible will be waived. You have the option of having the glass repaired rather than replaced.

H. Hired Auto Physical Damage – Increased Loss of Use Expenses

The **Coverage Extension** for **Loss Of Use Expenses** in the **Physical Damage Coverage Section** is replaced by the following:

Loss Of Use Expenses

For Hired Auto Physical Damage, we will pay expenses for which an "insured" becomes legally responsible to pay for loss of use of a vehicle rented or hired without a driver under a written rental contract or written rental agreement. We will pay for loss of use expenses if caused by:

Philip S. King

- (1) Other than collision only if the Declarations indicate that Comprehensive Coverage is provided for any covered "auto";
 - (2) Specified Causes Of Loss only if the Declarations indicate that Specified Causes Of Loss Coverage is provided for any covered "auto"; or
 - (3) Collision only if the Declarations indicate that Collision Coverage is provided for any covered "auto".
- However, the most we will pay for any expenses for loss of use is \$100 per day, to a maximum of \$3000.

I. Personal Effects Coverage

The following is added to the Coverage Provision of the Physical Damage Coverage Section:

Personal Effects Coverage

- a. We will pay up to \$750 for "loss" to personal effects which are:
 - (1) Personal property owned by an "insured"; and
 - (2) In or on a covered "auto".
- b. Subject to Paragraph a. above, the amount to be paid for "loss" to personal effects will be based on the lesser of:
 - (1) The reasonable cost to replace; or
 - (2) The actual cash value.
- c. The coverage provided in Paragraphs a. and b. above, only applies in the event of a total theft of a covered "auto". No deductible applies to this coverage. However, we will not pay for "loss" to personal effects of any of the following:
 - (1) Accounts, bills, currency, deeds, evidence of debt, money, notes, securities, or commercial paper or other documents of value.
 - (2) Bullion, gold, silver, platinum, or other precious alloys or metals; furs or fur garments; jewelry, watches, precious or semi-precious stones.
 - (3) Paintings, statuary and other works of art.
 - (4) Contraband or property in the course of illegal transportation or trade.
 - (5) Tapes, records, discs or other similar devices used with audio, visual or data electronic equipment.

Any coverage provided by this Provision is excess over any other insurance coverage available for the same "loss".

J. Tapes, Records and Discs Coverage

1. The Exclusion in Paragraph B.4.a. of Section III - Physical Damage Coverage in the Business Auto Coverage Form and the Exclusion in Paragraph B.2.c. of Section IV - Physical Damage Coverage in the Motor Carrier Coverage Form does not apply.
2. The following is added to Paragraph 1.a. Comprehensive Coverage under the Coverage Provision of the Physical Damage Coverage Section:

We will pay for "loss" to tapes, records, discs or other similar devices used with audio, visual or data electronic equipment. We will pay only if the tapes, records, discs or other similar audio, visual or data electronic devices:

- (a) Are the property of an "insured"; and
- (b) Are in a covered "auto" at the time of "loss".

The most we will pay for such "loss" to tapes, records, discs or other similar devices is \$500. The Physical Damage Coverage Deductible Provision does not apply to such "loss".

Philip S. King

K. Airbag Coverage

The Exclusion in Paragraph **B.3.a. of Section III – Physical Damage Coverage** in the Business Auto Coverage Form and the Exclusion in Paragraph **B.4.a. of Section IV – Physical Damage Coverage** in the Motor Carrier Coverage Form does not apply to the accidental discharge of an airbag.

L. Two or More Deductibles

The following is added to the **Deductible Provision of the Physical Damage Coverage Section:**

If an accident is covered both by this policy or Coverage Form and by another policy or Coverage Form issued to you by us, the following applies for each covered "auto" on a per vehicle basis:

1. If the deductible on this policy or Coverage Form is the smaller (or smallest) deductible, it will be waived; or
2. If the deductible on this policy or Coverage Form is not the smaller (or smallest) deductible, it will be reduced by the amount of the smaller (or smallest) deductible.

M. Physical Damage – Comprehensive Coverage – Deductible

The following is added to the **Deductible Provision of the Physical Damage Coverage Section:**

Regardless of the number of covered "autos" damaged or stolen, the maximum deductible that will be applied to Comprehensive Coverage for all "loss" from any one cause is \$5,000 or the deductible shown in the Declarations, whichever is greater.

N. Temporary Substitute Autos – Physical Damage

1. The following is added to **Section I – Covered Autos:**

Temporary Substitute Autos – Physical Damage

If Physical Damage Coverage is provided by this Coverage Form on your owned covered "autos", the following types of vehicles are also covered "autos" for Physical Damage Coverage:

Any "auto" you do not own when used with the permission of its owner as a temporary substitute for a covered "auto" you do own but is out of service because of its:

1. Breakdown;
 2. Repair;
 3. Servicing;
 4. "Loss"; or
 5. Destruction.
2. The following is added to the Paragraph **A. Coverage Provision of the Physical Damage Coverage Section:**

Temporary Substitute Autos – Physical Damage

We will pay the owner for "loss" to the temporary substitute "auto" unless the "loss" results from fraudulent acts or omissions on your part. If we make any payment to the owner, we will obtain the owner's rights against any other party.

The deductible for the temporary substitute "auto" will be the same as the deductible for the covered "auto" it replaces.

O. Amended Duties In The Event Of Accident, Claim, Suit Or Loss

Paragraph **a. of the Duties In The Event Of Accident, Claim, Suit Or Loss Condition** is replaced by the following:

- a. In the event of "accident", claim, "suit" or "loss", you must give us or our authorized representative prompt notice of the "accident", claim, "suit" or "loss". However, these duties only apply when the "accident", claim, "suit" or "loss" is known to you (if you are an individual), a partner (if you are a partnership), a member (if you are a limited liability company) or an executive officer or insurance manager (if you are a corporation). The failure of any

Philip J. Kelly

agent, servant or employee of the "insured" to notify us of any "accident", claim, "suit" or "loss" shall not invalidate the insurance afforded by this policy.

include, as soon as practicable:

- (1) How, when and where the "accident" or "loss" occurred and if a claim is made or "suit" is brought, written notice of the claim or "suit" including, but not limited to, the date and details of such claim or "suit";
- (2) The "insured's" name and address; and
- (3) To the extent possible, the names and addresses of any injured persons and witnesses.

If you report an "accident", claim, "suit" or "loss" to another insurer when you should have reported to us, your failure to report to us will not be seen as a violation of these amended duties provided you give us notice as soon as practicable after the fact of the delay becomes known to you.

P. Waiver of Transfer Of Rights Of Recovery Against Others To Us

The following is added to the **Transfer Of Rights Of Recovery Against Others To Us** Condition:

This Condition does not apply to the extent required of you by a written contract, executed prior to any "accident" or "loss", provided that the "accident" or "loss" arises out of operations contemplated by such contract. This waiver only applies to the person or organization designated in the contract.

Q. Employee Hired Autos – Physical Damage

Paragraph **b.** of the **Other Insurance** Condition in the **Business Auto Coverage Form** and Paragraph **f.** of the **Other Insurance – Primary and Excess Insurance Provisions** Condition in the **Motor Carrier Coverage Form** are replaced by the following:

For **Hired Auto Physical Damage** Coverage, the following are deemed to be covered "autos" you own:

- (1) Any covered "auto" you lease, hire, rent or borrow; and
- (2) Any covered "auto" hired or rented under a written contract or written agreement entered into by an "employee" or elected or appointed official with your permission while being operated within the course and scope of that "employee's" employment by you or that elected or appointed official's duties as respect their obligations to you.

However, any "auto" that is leased, hired, rented or borrowed with a driver is not a covered "auto".

R. Unintentional Failure to Disclose Hazards

The following is added to the **Concealment, Misrepresentation Or Fraud** Condition:

However, we will not deny coverage under this Coverage Form if you unintentionally:

- (1) Fail to disclose any hazards existing at the inception date of this Coverage Form; or
- (2) Make an error, omission, improper description of "autos" or other misstatement of information.

You must notify us as soon as possible after the discovery of any hazards or any other information that was not provided to us prior to the acceptance of this policy.

S. Hired Auto – World Wide Coverage

Paragraph **7a.(5)** of the **Policy Period, Coverage Territory** Condition is replaced by the following:

- (5) Anywhere in the world if a covered "auto" is leased, hired, rented or borrowed for a period of 60 days or less,

T. Bodily Injury Redefined

The definition of "bodily injury" in the **Definitions** Section is replaced by the following:

"Bodily injury" means bodily injury, sickness or disease, sustained by a person including death or mental anguish, resulting from any of these at any time. Mental anguish means any type of mental or emotional illness or disease.

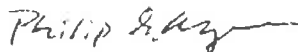

U. Expected Or Intended Injury

The **Expected Or Intended Injury** Exclusion in Paragraph B. Exclusions under Section II – Covered Auto Liability Coverage is replaced by the following:

Expected Or Intended Injury

"Bodily injury" or "property damage" expected or intended from the standpoint of the "insured". This exclusion does not apply to "bodily injury" or "property damage" resulting from the use of reasonable force to protect persons or property.

V. Physical Damage – Additional Temporary Transportation Expense Coverage

Paragraph A.4.a. of Section III – Physical Damage Coverage is replaced by the following:

4. Coverage Extensions

a. Transportation Expenses

We will pay up to \$50 per day to a maximum of \$1,000 for temporary transportation expense incurred by you because of the total theft of a covered "auto" of the private passenger type. We will pay only for those covered "autos" for which you carry either Comprehensive or Specified Causes of Loss Coverage. We will pay for temporary transportation expenses incurred during the period beginning 48 hours after the theft and ending, regardless of the policy's expiration, when the covered "auto" is returned to use or we pay for its "loss".

W. Replacement of a Private Passenger Auto with a Hybrid or Alternative Fuel Source Auto

The following is added to Paragraph A. Coverage of the Physical Damage Coverage Section:

In the event of a total "loss" to a covered "auto" of the private passenger type that is replaced with a hybrid "auto" or "auto" powered by an alternative fuel source of the private passenger type, we will pay an additional 10% of the cost of the replacement "auto", excluding tax, title, license, other fees and any aftermarket vehicle upgrades, up to a maximum of \$2500. The covered "auto" must be replaced by a hybrid "auto" or an "auto" powered by an alternative fuel source within 60 calendar days of the payment of the "loss" and evidenced by a bill of sale or new vehicle lease agreement.

To qualify as a hybrid "auto", the "auto" must be powered by a conventional gasoline engine and another source of propulsion power. The other source of propulsion power must be electric, hydrogen, propane, solar or natural gas, either compressed or liquefied. To qualify as an "auto" powered by an alternative fuel source, the "auto" must be powered by a source of propulsion power other than a conventional gasoline engine. An "auto" solely propelled by biofuel, gasoline or diesel fuel or any blend thereof is not an "auto" powered by an alternative fuel source.

X. Return of Stolen Automobile

The following is added to the Coverage Extension Provision of the Physical Damage Coverage Section:

If a covered "auto" is stolen and recovered, we will pay the cost of transport to return the "auto" to you. We will pay only for those covered "autos" for which you carry either Comprehensive or Specified Causes of Loss Coverage.

All other terms, conditions, provisions and exclusions of this policy remain the same.

Philip S. Arz

Kelly Cade

WORKERS' COMPENSATION AND EMPLOYERS' LIABILITY INSURANCE POLICY

WC 04 03 06 (Ed. 4-84)

**WAIVER OF OUR RIGHT TO RECOVER FROM OTHERS ENDORSEMENT—
CALIFORNIA**

This endorsement changes the policy to which it is attached effective on the inception date of the policy unless a different date is indicated below.

(The following "attaching clause" need be completed only when this endorsement is issued subsequent to preparation of the policy.)

This endorsement, effective on 10/1/2018 at 12:01 A.M. standard time, forms a part of
(DATE)

Policy No. WC 3736453-14 Endorsement No. 001

of the

(NAME OF INSURANCE COMPANY)

issued to HARDY & HARPER, INC.



Premium (if any) \$

Authorized Representative

We have the right to recover our payments from anyone liable for an injury covered by this policy. We will not enforce our right against the person or organization named in the Schedule. (This agreement applies only to the extent that you perform work under a written contract that requires you to obtain this agreement from us.)

You must maintain payroll records accurately segregating the remuneration of your employees while engaged in the work described in the Schedule.

The additional premium for this endorsement shall be 0% of the California workers' compensation premium otherwise due on such remuneration.

Schedule

Person or Organization

Job Description

All persons and/or organizations that are required by written contract or agreement with the insured, executed prior to the accident or loss, that waiver of subrogation be provided under this policy for work performed by you for that person and/or organization.

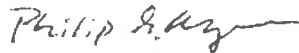

Endorsement No.: 1

This Endorsement, effective: December 31, 2018
(at 12:01 A.M. prevailing time at the address stated in Item 1. (b) of the Declarations)
forms a part of Policy No.: 0311-6679
Issued to: Hardy & Harper, Inc.
By: Allied World National Assurance Company

SCHEDULE OF UNDERLYING INSURANCE

<u>Type of Coverage</u>	<u>Insurer</u> <u>Policy Number</u> <u>Policy Period</u>	<u>Limits of Insurance</u>	
General Liability	United Specialty Insurance Company ATN-SF1813471 December 31, 2018 - December 31, 2019	US\$1,000,000 US\$2,000,000 US\$2,000,000	Each Occurrence General Aggregate Products-Completed Operations Aggregate
		Which is further Excess of: US\$200,000	Each Occurrence Self Insured retention

Defense costs:

Erode Do Not Erode

The Policy Limits Listed above and Do erode the Self Insured Retention Listed Above.

Employee Benefit Liability	United Specialty Insurance Company ATN-SF1813471 December 31, 2018 - December 31, 2019	US\$1,000,000 US\$1,000,000	Employee Benefit Each Wrongful Act or Series of Related Wrongful Acts Employee Benefits Liability Aggregate
		Retroactive Date: 12/31/2015	

Defense costs:

Erode Do Not Erode

The Limits of Insurance listed in the policy above.

Automobile Liability	American Zurich Insurance Company BAP 3736454-14 October 1, 2018 - October 1, 2019	US\$2,000,000	Combined Single Limit
----------------------	---	---------------	-----------------------

Defense costs:

Erode Do Not Erode

The Limits of Insurance listed in the policy above.

Employer Liability	Zurich American Insurance Company WC 3736453-14 October 1, 2018 - October 1, 2019	US\$1,000,000 US\$1,000,000 US\$1,000,000	Bodily Injury Each Accident Bodily Injury By Disease - Policy Aggregate Bodily Injury By Disease - Each Employee
--------------------	--	---	---

Philip S. Agnew

Defense costs:

Erode Do Not Erode

The Limits of Insurance listed in the policy above.

All other terms and conditions of this **policy** remain unchanged.

Allied World National Assurance Company

By:



Joseph Cellura

Title: President, North American Casualty Division

Date of Issuance: February 27, 2019





- Company Profile
- Company Search
- Company Information
- Old Company Names
- Agent for Service
- Reference Information
- NAIC Group List
- Lines of Business
- Workers' Compensation Complaint and Request for Action/Appeals Contact Information
- Financial Statements PDF's
 - Annual Statements
 - Quarterly Statements
- Company Complaint
 - Company Performance & Comparison Data
 - Company Enforcement Action
 - Composite Complaints Studies
- Additional Info
 - Find A Company Representative In Your Area
 - View Financial Disclaimer

COMPANY PROFILE

Company Information

ZURICH AMERICAN INSURANCE COMPANY

**1299 ZURICH WAY
SCHAUMBURG, IL 60196
800-936-5873**

Old Company Names **Effective Date**

Agent For Service

Melissa DeKoven
2710 Gateway Oaks Drive, Suite 150N
Sacramento CA 95833-3505

Reference Information

NAIC #:	16535
California Company ID #:	4581-5
Date Authorized in California:	01/01/1999
License Status:	UNLIMITED-NORMAL
Company Type:	Property & Casualty
State of Domicile:	NEW YORK

[back to top](#)

NAIC Group List

NAIC Group #: **0212** ZURICH INS GRP

Lines Of Business

The company is authorized to transact business within these lines of insurance. For an explanation of any of these terms, please refer to the [glossary](#).

- AIRCRAFT
- AUTOMOBILE
- BOILER AND MACHINERY
- BURGLARY
- COMMON CARRIER LIABILITY
- CREDIT
- DISABILITY
- FIRE
- LIABILITY
- MARINE
- MISCELLANEOUS
- PLATE GLASS
- SPRINKLER
- SURETY
- TEAM AND VEHICLE
- WORKERS' COMPENSATION

[back to top](#)



Company Profile

Company Search

→ Company Information

Old Company Names

Agent for Service

Reference Information

NAIC Group List

Lines of Business

Workers' Compensation Complaint and Request for Action/Appeals Contact Information

Financial Statements PDF's

Annual Statements

Quarterly Statements

Company Complaint

Company Performance & Comparison Data

Company Enforcement Action

Composite Complaints Studies

Additional Info

Find A Company Representative In Your Area

View Financial Disclaimer

COMPANY PROFILE

Company Information

ALLIED WORLD ASSURANCE COMPANY (U.S.) INC.

199 WATER STREET, 29TH FLOOR
NEW YORK, NY 10038
800-433-8880

Old Company Names

Effective Date

COMMERCIAL UNDERWRITERS INSURANCE COMPANY	10/23/2002
---	------------

Agent For Service

Melissa DeKoven
2710 Gateway Oaks Drive, Suite 150N
Sacramento CA 95833-3505

Reference Information

NAIC #:	19489
California Company ID #:	3577-4
Date Authorized in California:	12/31/1992
License Status:	UNLIMITED-NORMAL
Company Type:	Property & Casualty
State of Domicile:	DELAWARE

[back to top](#)

NAIC Group List

NAIC Group #: **0158** FAIRFAX FIN GRP

Lines Of Business

The company is authorized to transact business within these lines of insurance. For an explanation of any of these terms, please refer to the [glossary](#).

AIRCRAFT
AUTOMOBILE
BOILER AND MACHINERY
BURGLARY
COMMON CARRIER LIABILITY
DISABILITY
FIRE
LIABILITY
MARINE
MISCELLANEOUS
PLATE GLASS
SPRINKLER
SURETY
TEAM AND VEHICLE
WORKERS' COMPENSATION

[back to top](#)



Company Profile

Company Search

→ Company Information

Old Company Names

Agent for Service

Reference Information

NAIC Group List

Lines of Business

Workers'

Compensation

Complaint and

Request for

Action/Appeals

Contact Information

Financial Statements PDF's

Annual Statements

Quarterly Statements

Company Complaint

Company Performance & Comparison Data

Company Enforcement Action

Composite Complaints Studies

Additional Info

Find A Company Representative In Your Area

View Financial Disclaimer

COMPANY PROFILE

Company Information

EXECUTIVE RISK INDEMNITY INC.
202B HALL'S MILL ROAD
WHITEHOUSE STATION, NJ 08889
908990392207

Old Company Names

Effective Date

AMERICAN EXCESS INSURANCE COMPANY	05/12/1987
ERIC REINSURANCE COMPANY	11/18/1992
EXECUTIVE RE INDEMNITY INC.	06/21/1995
EXECUTIVE RISK INDEMNITY, INC.	08/02/2000

Agent For Service

Vivian Imperial
 818 WEST SEVENTH STREET
 SUITE 930
 LOS ANGELES CA 90017

Reference Information

NAIC #:	35181
California Company ID #:	2342-4
Date Authorized in California:	12/07/1979
License Status:	UNLIMITED-NORMAL
Company Type:	Property & Casualty
State of Domicile:	DELAWARE

[back to top](#)

NAIC Group List

NAIC Group #: [0626](#) Chubb Ltd Grp

Lines Of Business

The company is authorized to transact business within these lines of insurance. For an explanation of any of these terms, please refer to the [glossary](#).

AIRCRAFT
 AUTOMOBILE
 BOILER AND MACHINERY
 BURGLARY
 COMMON CARRIER LIABILITY
 CREDIT
 DISABILITY
 FIRE
 LIABILITY
 MARINE
 MISCELLANEOUS
 PLATE GLASS
 SPRINKLER
 SURETY
 TEAM AND VEHICLE
 WORKERS' COMPENSATION

[back to top](#)