

**SUBMITTAL TO THE FLOOD CONTROL AND
WATER CONSERVATION DISTRICT
BOARD OF SUPERVISORS
COUNTY OF RIVERSIDE, STATE OF CALIFORNIA**



ITEM: 11.2
(ID # 13229)

MEETING DATE:
Tuesday, August 25, 2020

FROM: FLOOD CONTROL DISTRICT:

SUBJECT: FLOOD CONTROL DISTRICT: Approve Addenda to Plans and Specifications and Contract Documents; Accept Low Bid and Award the Contract for the Palm Canyon Wash, Stage 93 Emergency Levee Restoration, Project No. 6-0-00040-93, District 4. [\$1,932,839 - District Funds 100%]

RECOMMENDED MOTION: That the Board of Supervisors:

1. Approve the Addendum No. 1 to the Plans and Specifications and Contract Documents issued prior to the July 1, 2020 bid opening;
2. Waive any minor bid irregularities, and accept the low bid submitted by the firm of Sukut Construction, LLC for \$1,876,543 for the construction of the above-referenced project;
3. Award the Contract to Sukut Construction, LLC, and authorize the Chairwoman of the Board of Supervisors of the Riverside County Flood Control and Water Conservation District (District) to execute the Construction Agreement on behalf of the District; and
4. Direct the Clerk of the Board to return three (3) copies of the executed Palm Canyon Wash, Stage 93 Emergency Levee Restoration contract documents to the District.

ACTION: Policy

Jason Uhley, GENERAL MGR-CHF FLD CNTRL ENG

8/12/2020

MINUTES OF THE BOARD OF SUPERVISORS

On motion of Supervisor Spiegel, seconded by Supervisor Hewitt and duly carried, IT WAS ORDERED that the above matter is approved as recommended.

Ayes: Spiegel, Washington, Perez and Hewitt
Nays: None
Absent: Jeffries
Date: August 25, 2020
xc: Flood

Kecia R. Harper
Clerk of the Board

By:
Deputy

**SUBMITTAL TO THE FLOOD CONTROL AND WATER CONSERVATION DISTRICT BOARD
OF SUPERVISORS
COUNTY OF RIVERSIDE, STATE OF CALIFORNIA**

FINANCIAL DATA	Current Fiscal Year:	Next Fiscal Year:	Total Cost:	Ongoing Cost
COST	\$1,932,839	\$0	\$1,932,839	\$0
NET COUNTY COST	\$0	\$0	\$0	\$0
SOURCE OF FUNDS: 25160 947500 548200 Zone 6 Infrastructure (97%) 25160 947500 523220 Zone 6 License & Permits (3%)			Budget Adjustment: No	
			For Fiscal Year: 20/21	

C.E.O. RECOMMENDATION: Approve

BACKGROUND:

Summary

On May 19, 2020 (Agenda Item 11.4, MT#12418), the Board of Supervisors for the District authorized the Clerk of the Board to advertise for construction contract bids for the Palm Canyon Wash, Stage 93 Emergency Levee Restoration project.

The District opened bids for Palm Canyon Wash, Stage 93 Emergency Levee Restoration on July 1, 2020. Ten contractors submitted a bid in response to this call for bids. The lowest responsible bid was received from Sukut Construction, LLC for the sum of \$1,876,543. The bid documents have been reviewed by County Counsel and District staff. Two immaterial irregularities were noted on the bid bond, however, it was determined that the bid is valid and binding, and that the irregularities did not create an unfair advantage or directly affect the price of their bid. The bid was otherwise found to be responsive, and District staff recommends that the Board waive any minor irregularities found in the Contractor's bid.

On July 2, 2020, the second lowest bidder, Bosco Constructors, Inc., requested Sukut's bid documents and ultimately sent a letter on July 6, 2020 protesting Sukut's bid. The protest claimed that the execution of the bid documents was not valid and that the bid was unbalanced. The letter has been reviewed by District staff and Counsel, and both claims were determined to be unfounded.

On August 3, 2020, a Notice of Intent to Award the contract to Contractor was posted under Public Notices at rcflood.org. Pursuant to Article 3, Section 3.3 of the Instructions to Bidders, bidders are provided five days to submit any protest of the intent to award. No additional protests were received by the deadline.

The Contractor has executed the construction contract and provided the bonds and insurance documents, which meet the requirements of the contract.

The Fiscal Data listed includes this bid amount plus the required Coachella Valley Multiple Species Habitat Conservation Plan mitigation payment (see Additional Fiscal Information section below).

**SUBMITTAL TO THE FLOOD CONTROL AND WATER CONSERVATION DISTRICT BOARD
OF SUPERVISORS
COUNTY OF RIVERSIDE, STATE OF CALIFORNIA**

The Palm Canyon Wash Flood Control Facility is located in the southern portion of the city of Palm Springs. The emergency work consists of the repair and restoration of existing damaged levee sections in addition to necessary facility scour protection in the vicinity of Murray Canyon Drive and Toledo Avenue continuing approximately 800 feet downstream of Araby Drive. See Project Location Map.

County Counsel has reviewed the construction contract with exhibits and approved as to form.

CEQA Compliance

On May 19, 2020 (Agenda Item 11.4, MT#12418), the Board of Supervisors for the District found that the Palm Canyon Wash, Stage 93 Emergency Levee Restoration ("Project") is exempt from the California Environmental Quality Act (CEQA) pursuant to the State CEQA Guidelines Section 15269(a), (b), and (c) and that nothing further is required. In accordance with CEQA, a Notice of Exemption was prepared by the District and filed by the Clerk of the Board with the County Clerk.

Prev. Agn. Ref.: MT#12418 11.4 of 05/19/20 Advertise

Impact on Residents and Businesses

Impact on local residents and businesses during construction is considered to be minimal. Residents and businesses could experience general construction noise or dust from heavy equipment.

This emergency work will restore and enhance critical sections of the levee and ensure continued flood protection to adjacent communities during future storm events. The project will repair and restore damaged levee sections resulting from the attack of concentrated flows at the existing levee face. Included in this work is additional scour protection to restore the original design intent by deepening levee panels or providing extensions in areas deemed insufficient.

Additional Fiscal Information

Pursuant to the Implementing Agreement for the Coachella Valley Multiple Species Habitat Conservation Plan (MSHCP) executed on October 30, 2007, the Financial Data listed is comprised of the bid amount of \$1,876,543 for Contractor, plus up to \$56,296 (3% of bid) for MSHCP mitigation, for a total of \$1,932,839 (bid plus 3% amount). The MSHCP Implementing Agreement requires the District to make a payment to the Coachella Valley Conservation Commission for up to 3% of the total capital costs (bid amount described above) as required mitigation for the construction of flood control facilities. The actual mitigation payment that will be made by the District may be reduced based on acquisition of replacement habitat for the benefit of Covered Species, as defined in the Implementing Agreement and the MSHCP.

Contract History and Price Reasonableness

**SUBMITTAL TO THE FLOOD CONTROL AND WATER CONSERVATION DISTRICT BOARD
OF SUPERVISORS
COUNTY OF RIVERSIDE, STATE OF CALIFORNIA**

Pursuant to Public Contract Code 21091, invitation of sealed bids was solicited by advertising in print and digital media. The Contractor's bid was reasonable and is approximately 34% below the project engineer's estimate.

ATTACHMENTS:

1. Addendum No. 1
2. Bid Summary/Abstract
3. Protest Letter and Response
4. Project Location Map
5. Contract Documents (Sheets XXIII through XXXIV) and Certificate of Liability Insurance - 4 copies



Jason Farin, Principal Management Analyst 8/17/2020



Gregory H. Priamos, Director County Counsel 8/13/2020

SPECIFICATIONS and CONTRACT DOCUMENTS

for the CONSTRUCTION of

**PALM CANYON WASH, STAGE 93
EMERGENCY LEVEE RESTORATION**

PROJECT NO. 6-0-00040

RIVERSIDE COUNTY, CALIFORNIA



MAY 19 2020 11.4 pfs

FORM APPROVED COUNTY COUNSEL
BY: Synthia M. Gunzel 5-6-2020
SYNTHIA M. GUNZEL DATE

AUG 25 2020 11.2



RIVERSIDE COUNTY FLOOD CONTROL
AND WATER CONSERVATION DISTRICT

June 22, 2020

ADDENDUM NO. 1
TO
PALM CANYON WASH, STAGE 93 EMERGENCY LEVEE RESTORATION

RIVERSIDE COUNTY, CALIFORNIA

Bid Opening Date: Wednesday, June 24, 2020 at 2:00 p.m.

BID OPENING

CHANGE Bid Opening Date to: Wednesday, July 1, 2020 at 2:00 p.m.

PROPSAL

REPLACE PROPOSAL in its entirety (Pages XV and XVa) to accommodate the addition of a signature line on the bottom of Page XVa for acknowledgment of this Addendum.

DETAILED SPECIFICATIONS

REPLACE 21.2 Existing Riprap Removal, Temporary Stockpiling and Final Placement to read:

21.2 Existing Riprap Removal, Temporary Stockpiling and Final Placement - The contract item Existing Riprap Removal, Temporary Stockpiling and Final Placement includes all costs associated with the removal of all existing levee riprap and rock within the excavation area, temporary stockpiling, and final placement as shown on the project drawings. The existing riprap is estimated as follows: 3-ton rock – **970 tons**, 1-ton rock – 255 tons, and smaller miscellaneous rock as shown on the project drawings. All removed riprap and rock shall be stockpiled onsite in an area designated by the Contractor for later use. Final placement of all stockpiled riprap and rock shall be as shown on the project drawings and as directed by the Engineer. Export of any removed riprap and rock will not be permitted.

RESPONSE TO QUESTIONS

Attached to this addendum is Response to Questions.

NOTE: Bidders are required to acknowledge receipt of all addenda at the bottom of Page XVa of the PROPOSAL. Failure to acknowledge all addenda on the bid form may cause the bid to be considered not responsive to the invitation, which would require rejection of the bid.

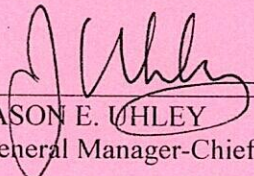

JASON E. UHLEY
General Manager-Chief Engineer

RESPONSE TO QUESTIONS

Palm Canyon Wash, Stage 93 Emergency Levee Restoration

This document has been prepared to clarify elements of the Contract Documents for the above-referenced project for which the District has received questions.

Question 1	On plan sheet 2 of 12 looking at the profile (at approx. STA. 71+00) there is note 11 called out where the rip rap going to be stocked piled. Is this note 11 correct?
<i>Answer</i>	<i>Note 11 as shown in the profile view (at approx. STA. 71+00) on Sheet 2 of 12 is incorrect. This callout should correspond with Construction Note 18 to be consistent with the note shown in the plan view.</i>
Question 2	<p>The bid item description for the Dewatering bid item directs the bidder to comply with waste discharge order R7-2015-0006 and does not talk about including costs for the dewatering itself.</p> <p>The geotechnical investigation did not indicate any groundwater at the depths of excavation anticipated on this project. Is it reasonable to say that because contractors should not be expected to be geotechnical engineers (CA public contracting code 1104) and that there is no geotechnical data to estimate dewatering costs with, that any dewatering equipment/work required will be paid as a differing site condition (extra work)?</p> <p>If the Flood Control District would like costs for dewatering carried in the contract awarded, could consideration be made to make this an allowance that would be the same on all contractor's proposals instead of a bid item?</p>
<i>Answer</i>	<p><i>The geotechnical report by BTC Labs - Vertical Five (aka NV5) dated May 5, 2014 as provided in Appendix "C" of the project specifications is the best available information the District has regarding the existing groundwater conditions at the location of the depicted borings.</i></p> <p><i>If the successful bidder is confronted with substantially different site conditions from what is presented in the project specifications, the District will utilize Sections 2.07 and 2.08 of the General Provisions regarding the definition of Extra Work and the payment of such work.</i></p>
Question 3	Confirmation of time and location of the bid opening?
<i>Answer</i>	<p><i>Bid proposals shall be submitted by 2:00 p.m. on Wednesday July 1, 2020 at 1995 Market Street, Riverside, California. At such time, all bidders and attendees will be directed to the bid opening location at the District.</i></p> <p><i>The bid opening will be open for in-person attendance and will not be live streamed. Due to COVID-19, the District requests that attendees bring and wear appropriate face coverings while at the District's facility.</i></p>

PROPOSAL

For the Construction of **Palm Canyon Wash, Stage 93 Emergency Levee Restoration**, located in the city of Palm Springs, Riverside County, consisting of the following estimated quantities:

SECT. NO.	ITEM NO.	ITEM OF WORK	UNIT	QUANTITY	UNIT COST	TOTAL COST
10	1.	Mobilization	L.S.	---	---	
11	2.	Water Control	L.S.	---	---	
13	3.	Clearing and Miscellaneous Work	L.S.	---	---	
14	4.	Excavation	C.Y.	72,000		
14	5.	Backfill	C.Y.	61,500		
14	6.	Embankment	C.Y.	10,500		
15	7.	Trench Safety System	L.S.	---	---	
16	8.	Class "A" Concrete, Slope Paving	C.Y.	1,750		
16	9.	Class "B" Concrete, 2' Cutoff Wall	L.F.	1,455		
16	10.	Class "B" Concrete, 4' Cutoff Wall	L.F.	130		
20	11.	Remove and Reinstall Fence	L.F.	200		
20	12.	Remove and Reinstall Gate	EACH	3		
21	13.	Existing Riprap Removal, Temporary Stockpiling and Final Placement	L.S.	---	---	
21	14.	Air-Blasting	L.S.	---	---	
21	15.	Existing 4" Unreinforced Concrete Slope Paneling Breaking and Removal, Temporary Stockpiling and Final Placement	L.S.	---	---	
21	16.	Toe Extension Epoxy	L.F.	2,000		
21	17.	Perimeter Demarcation Fencing	L.F.	4,000		
21	18.	Extra Directed Work	L.S.	---	---	150,000.00
27	19.	Dust Abatement	L.S.	---	---	

PROPOSAL contd.

SECT. NO.	ITEM NO.	ITEM OF WORK	UNIT	QUANTITY	UNIT COST	TOTAL COST
29	20.	Stormwater and Non-Stormwater Pollution Control	L.S.	---	---	
29	21.	Non-Stormwater Discharge or Dewatering	L.S.	---	---	

For the Total Bid Proposal of:

TOTAL COST
(State in Figures) \$

Name of Contractor

Signature of Contractor's authorized representative

Name: _____

Title: _____

Address

S.S.N. or E.I.N.

City, State, Zip

Contractor's License No. and Classification

Telephone Number Fax Number

Contractor's DIR Registration No.

Email

If bidder is a corporation, corporate seal and attestation shall be provided below.

Dated: _____

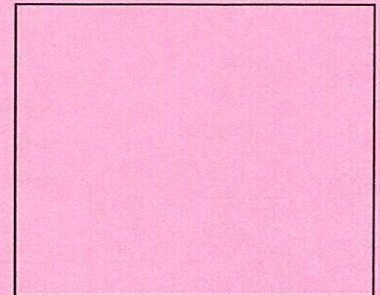

ADDENDUM NO. 1 ACKNOWLEDGED

Signature



SPECIFICATIONS and CONTRACT DOCUMENTS
for the CONSTRUCTION of
PALM CANYON WASH, STAGE 93
EMERGENCY LEVEE RESTORATION

PROJECT NO. 6-0-00040

These specifications and contract documents have been prepared under the direction of the following Registered Civil Engineers:

Recommended By:

Design Engineer

April 29, 2020

Date



Approved By:

General Manager - Chief Engineer

4-28-2020

Date



TABLE OF CONTENTS

<u>Title</u>	<u>Page</u>
Notice Inviting Bids to Contractors	II-III
Instructions to Bidders	IV-XIII
Bid Proposal	
Contractor's Proposal	XIV-XV
List of Subcontractors	XVI
Experience Statement	XVII
Statement of Licensure	XVIII
Non-Collusion Declaration	XIX
Iran Contracting Act Certification	XX
Bid Bond	XXI-XXII
Construction Agreement, Bonds and Other Forms	
Construction Agreement	XXIII-XXIV
Exhibit A	XXV
Performance Bond	XXVI-XXVIII
Payment Bond	XXIX-XXX
Workers' Compensation Contractor Certificate	XXXI
Declaration of Sufficiency of Funds	XXXII-XXXIV

GENERAL PROVISIONS

Section I - Definition of Terms	1
1.01 Terms	
1.02 Similarity of Words	
Section II - Scope of Work	2
2.01 Work to be Done	
2.02 Construction Schedule	
2.03 Drawings and Specifications on the Work	
2.04 Estimate of Quantities	
2.05 Protests	
2.06 Alterations	
2.07 Extra Work	
2.08 Payment for Extra Work	
2.09 Rights of Way	
2.10 Cleaning Up	
Section III - Control of the Work	6
3.01 Authority of the Engineer	
3.02 Detail Drawings	
3.03 Conformity with Plans and Allowable Deviations	
3.04 Interpretation of Plans and Specifications	
3.05 Superintendence	
3.06 Lines and Grades	

TABLE OF CONTENTS - CONTD.

GENERAL PROVISIONS contd.

	<u>Page</u>
3.07 Inspection of Work	
3.08 Removal of Defective and Unauthorized Work	
3.09 Equipment and Plant	
3.10 Final Inspection	
Section IV - Control of Material	9
4.01 District Furnished Materials	
4.02 Source of Supply and Quality of Materials	
4.03 Samples and Tests	
4.04 Digging Trenches or Other Excavations	
4.05 Storage of Materials	
4.06 Defective Materials	
4.07 Assignment of Claims	
Section V - Legal Relations and Responsibility	11
5.01 Laws to be Observed	
5.02 Contractor's Responsibility	
5.03 Contractor's Responsibility for Work	
5.04 Property Rights in Materials	
5.05 Permits and Licenses	
5.06 Royalties and Patents	
5.07 Sanitary Provisions	
5.08 Public Safety	
5.09 Use of Explosives	
5.10 Provisions for Emergencies	
5.11 Unforeseen Difficulties	
5.12 Access to the Work	
5.13 Guarantee of Work	
5.14 Damages by Act of God	
Section VI - Prosecution and Progress	18
6.01 Progress of the Work	
6.02 Overtime Work and Work at Night	
6.03 Subcontracting	
6.04 Character of Workmen	
6.05 Temporary Suspension of the Work	
6.06 Time of Completion and Damages	
6.07 Delays and Extension of Time	
6.08 Assignment	
6.09 Termination of Contract	

TABLE OF CONTENTS - CONTD.

GENERAL PROVISIONS contd.

	<u>Page</u>
Section VII - Payment	22
7.01 Scope of Payments	
7.02 Payment and Compensation for Altered Quantities	
7.03 Force Account Payment	
7.04 Acceptance	
7.05 Deductions from Payments	
7.06 Partial Payments	
7.07 Delayed Payments	
7.08 Final Payment	
7.09 Claims Resolution - Claims up to \$375,000	
7.10 Claims Resolution - All Claims (Public Contract Code Section 9204)	
Section VIII - General	34
8.01 Cooperation between Contractors	
8.02 Insurance - Indemnification/Hold Harmless/Defend	
8.03 Public Utilities	
8.04 Protection of Existing Street Facilities	
8.05 Diversion and Control of Water	
8.06 Dust Abatement	
8.07 Project Signs	
8.08 Examination of Plans, Specifications, Contract, and Site of Work	
Section IX - Watering	41
9.01 Description	
Section X - Public Convenience, Traffic Control and Detours	41
10.01 General	
10.02 Signs	
10.03 Materials Storage	

SPECIAL PROVISIONS

Section 1 - General	43
1.1 Drawings and Specifications	
1.2 Submittals to District	
Section 2 - Time of Completion, Damages and Legal Holidays	43
2.1 General	
2.2 Notice to Proceed	
2.3 Damages	
2.4 Legal Holidays	

TABLE OF CONTENTS - CONTD.

SPECIAL PROVISIONS contd.

	<u>Page</u>
Section 3 - Force Account Payment	45
3.1 Labor Surcharge	
3.2 Equipment Rental	
Section 4 - Protection of Existing Utilities	45
4.1 General	
4.2 Cooperation with Utilities Relocated by Others or Protected in Place	
Section 5 - Project Site Maintenance	46
Section 6 - Special Requirements	46
6.1 National Pollutant Discharge Elimination System (NPDES)	
6.2 Sanitation	
6.3 Confined Space Compliance	
6.4 Heavy Equipment Working Hours	
6.5 Business License	
6.6 Toxic Material Disposal	
6.7 Survey Crew	
6.8 Survey Monuments	
6.9 Job Trailer Site	
6.10 Construction Tolerances	
6.11 Surplus Excavated Material	
6.12 Project Sign	
6.13 Liability Insurance	
6.14 Fish and Game Code Section 1610 Emergency Work Compliance	
6.15 404 Permit Compliance	
6.16 401 Certification Compliance	
6.17 Coordination with Tribal Monitoring	
6.18 Accidental Discovery	
6.19 Nesting Bird Pre-Construction Survey	
6.20 Coordination with Regulatory and Environmental Permitting Staff	
6.21 Installation of Roadway Lighting or Permanent Light Sources	
6.22 Coordination with Biological Monitor	
6.23 Coordination with Smoke Tree Stables	
6.24 Pedestrian Access	
Section 7 - Soils Report	54
Section 8 - Not Used	54
Section 9 - Payment	54

TABLE OF CONTENTS - CONTD.

DETAILED SPECIFICATIONS

	<u>Page</u>
Section 10 - Mobilization	55
10.1 Description	
10.2 Payment	
Section 11 - Water Control	55
11.1 Description	
11.2 Water Control	
11.3 Measurement and Payment	
Section 12 - Not Used	56
Section 13 - Clearing and Miscellaneous Work	56
13.1 Description	
13.2 Clearing and Miscellaneous Work	
13.3 Payment	
Section 14 - Earthwork	57
14.1 Description	
14.2 General Excavation Requirements	
14.3 Excavation	
14.4 General Backfill and Embankment Requirements	
14.5 Testing	
14.6 Backfill	
14.7 Embankment	
14.8 Measurement	
14.9 Payment	
Section 15 - Trench Safety System	61
15.1 Description	
15.2 Trench Safety System	
15.3 Measurement and Payment	
Section 16 - Concrete Construction	62
16.1 Description	
16.2 General Requirements	
16.3 Material and Methods	
16.4 General Reinforcing Steel Requirements	
16.5 Consistency	
16.6 Placing	
16.7 Form Removal and Finish	

TABLE OF CONTENTS - CONTD.

DETAILED SPECIFICATIONS contd.

	<u>Page</u>
16.8 Curing	
16.9 Joints	
16.10 Class "A" Concrete, Slope Paving	
16.11 Class "B" Concrete, 2' Cutoff Wall	
16.12 Class "B" Concrete, 4' Cutoff Wall	
16.13 Measurement	
16.14 Payment	
Section 17 through Section 19 - Not Used	66
Section 20 - Fences and Gates	66
20.1 Description	
20.2 Remove and Reinstall Fence	
20.3 Remove and Reinstall Gate	
20.4 Measurement	
20.5 Payment	
Section 21 - Miscellaneous	67
21.1 Description	
21.2 Existing Riprap Removal, Temporary Stockpiling and Final Placement	
21.3 Air-Blasting	
21.4 Existing 4" Unreinforced Concrete Slope Paneling Breaking and Removal, Temporary Stockpiling and Final Placement	
21.5 Toe Extension Epoxy	
21.6 Perimeter Demarcation Fencing	
21.7 Extra Directed Work	
21.8 Measurement	
21.9 Payment	
Section 22 through Section 26 - Not Used	69
Section 27 - Dust Abatement	69
27.1 Description	
27.2 Dust Abatement	
27.3 Payment	
Section 28 - Not Used	70

TABLE OF CONTENTS - CONTD.

DETAILED SPECIFICATIONS contd.

	<u>Page</u>
Section 29 - Stormwater and Non-Stormwater Pollution Control	70
29.1 Description	
29.2 General Requirements	
29.3 Pollution Prevention Plan Preparation and Approval	
29.4 Pollution Prevention Plan Amendments	
29.5 Pollution Prevention Plan Implementation	
29.6 Non-Stormwater Discharge or Dewatering	
29.7 Payment	
 Section 30 and Section 31 - Not Used	 78
 Appendix "A" - South Coast Air Quality Management District Rule 403 and Rule 403.1	 79
 Appendix "B" - Project Sign	 80
 Appendix "C" - Log of Soil Borings Geotechnical Report	 81
 Appendix "D" - U.S. Army Corps of Engineers Section 404 Permit	 82
 Appendix "E" - State Water Resources Control Board Section 401 Permit Water Quality Certification	 83
 Drawing No. 6-0415	 Sheets 1 through 12

NOTICE INVITING BIDS TO CONTRACTORS

Riverside County Flood Control and Water Conservation District hereinafter called "District", invites sealed proposals for construction of:

**Palm Canyon Wash, Stage 93 Emergency Levee Restoration
Project No. 6-0-00040-93
located in the city of Palm Springs
Riverside County, California**

On or after **May 19, 2020**, the Specifications and Contract Documents may be examined and obtained through www.ebidboard.com. The Specifications and Contract Documents may also be viewed at <http://rcflood.org/Business/Construction-Bid-Opps/> and purchased for **\$60.00** per set if picking up and **\$65.00** per set if requesting to be mailed by contacting the District office at 951.955.1200. The Specification and Contract Documents are also offered on CD-ROM for \$10.00 if pickup up and \$15.00 if requesting to be mailed by contacting the District office at 951.955.1200. No refunds.

Each proposal must be accompanied by a bid security in the form of a certified check, cashier's check or bid bond equal to ten percent (10%) of the amount bid, payable to the Riverside County Flood Control and Water Conservation District as a guarantee that the Contractor will, if awarded the contract, execute a satisfactory contract and furnish the required bonds and proof of insurance.

Bid Proposals must be placed in a sealed envelope clearly marked "Bid Proposal". Bid Proposals must be in accordance with the Contract Documents and Articles 1 through 4 of the Instructions to Bidders and filed with the District by **2:00 p.m. on Wednesday, June 24, 2020** at 1995 Market Street, Riverside, California, which time and place are fixed for the public opening of bids.

Any questions, requests for information and requests for clarification or interpretation of the Specifications must be submitted in writing to the District attention:

Ryan Gosliga
Email: rgosliga@rivco.org
OR
Hard Copy: Riverside County Flood Control and Water Conservation District
1995 Market Street, Riverside, CA 92501
Attn: Ryan Gosliga

Questions or requests must be received **no later than 5:00 p.m. on Monday, June 15, 2020**.

Pursuant to Labor Code Section 1771.1, any Contractor bidding and subcontractors to be listed on a Bid Proposal are subject to Public Contract Code Section 4104 and shall not be eligible to bid unless currently registered with the Department of Industrial Relations and qualified to perform public works pursuant to Labor Code Section 1725.5. No Contractor or subcontractor may be awarded a public works project or enter into a Contract without proof of current registration to perform public works.

General prevailing rate of per diem wages and general prevailing rate of per diem wages for holiday and overtime work, including employer payments for health and welfare, pension, vacation, apprentices and similar purposes for each craft, classification or type of workman needed for execution of

contracts under the jurisdiction of District have been obtained by the Board of Supervisors of the District from the Director of Industrial Relations of the State of California for the area where the work is to be done. The said determinations are on file in the principal office of the District, and will be made available to any interested person upon request.

THIS PROJECT IS SUBJECT TO COMPLIANCE MONITORING AND ENFORCEMENT BY THE DEPARTMENT OF INDUSTRIAL RELATIONS. The awarded prime Contractor shall post job site notices, including a copy of the prevailing rate of per diem wages determinations made by the Director for the Department of Industrial Relations and other notices prescribed by regulations and comply with the provisions of the California Labor Code, including, without limitation, Sections 1771.4, 1773.1, 1773.2, 1774, 1775, 1776, and 1777.5.

Contractor shall furnish the records specified in Labor Code Section 1776, including but limited to the certified payroll records, directly to the Labor Commissioner for the Department of Industrial Relations.

Substitution of securities for any moneys withheld by District shall be permitted as provided for by Section 22300 of the California Public Contract Code.

Contractors submitting proposals for this project shall have an active and in good standing Class "A" Contractor's license from the State of California in order to be considered eligible for the contract award. The license(s) shall remain active and in good standing throughout the entire duration of the project.

With the submittal of the Bid Proposal and other Contract Documents, the Contractor shall submit for approval by the District documented evidence of satisfaction of all of the Bidder Qualifications listed above and in accordance with Articles 1 through 4 of the Instructions to Bidders.

Dated: May 19, 2020

RIVERSIDE COUNTY FLOOD CONTROL
AND WATER CONSERVATION DISTRICT

KECIA HARPER
Clerk of the Board

BY 
Deputy



INSTRUCTIONS TO BIDDERS

ARTICLE 1 GENERAL CONDITIONS

1.1 DEFINITIONS

Capitalized terms used on the Contract Documents shall have the meanings assigned to them in the Construction Agreement, Bonds, other Forms, General Provisions, and Specifications and Contract Documents that are included in the Contract Documents. Capitalized terms not so defined shall have the meanings assigned to them in, or if none is assigned as reasonably interpreted according to the context of, the portion of the Contract Documents where such terms are used.

1.2 QUANTITIES

The amount of work to be done or materials to be furnished under the contract as noted in the proposal, are but estimates and are not to be taken as an expressed or implied statement that the actual amount of work or materials will correspond to the estimate.

The right is reserved to increase or decrease or to entirely eliminate certain items from the work or materials if found desirable or expedient.

The Contractor will be allowed no claims for anticipated profits, loss of profits or for any damages of any sort because of any difference between the estimated and the actual amounts of work done, or materials furnished or used in the completed project.

The Contractor is cautioned against unbalancing of his bid by prorating his overhead into one or two items only when there are a number of items on the schedule. The overhead and indirect charges should be prorated on all items in schedule.

1.3 AGREEMENT OF FIGURES

If the unit prices and the total amounts named by the bidder in the proposal do not agree, the unit prices alone will be considered as representing the bidder's intention.

1.4 "OR EQUAL"

Pursuant to Division 2, Chapter 3, Article 5, commencing at Section 3400 of the Public Contract Code, all specifications shall be deemed to include the words "or equal", provided, however, that permissible exceptions or other requirements shall be specifically noted in the specifications. Any "equal" proposed by the Contractor must be described in the Contractor's Proposal.

1.5 INSPECTION OF SITE

Bidders must examine the site and acquaint themselves with all conditions affecting the work.

Information derived from maps, plans or specifications, or from the Chief Engineer or his assistants, will not relieve the successful bidder from properly carrying out all the terms of the written contract.

By the submitting of a proposal, the bidder will be held to have personally examined the site and the drawings, to have carefully read the specifications and to have satisfied himself as to his ability to meet all the difficulties attending the execution of the proposed contract before the delivery of his proposal and agrees that if he is awarded the contract, he will make no claim against the District and the County of Riverside, (including their respective officers, districts, special districts and departments, their respective directors, officers, Board of Supervisors, elected and appointed officials, employees, agents and representatives) based on ignorance or misunderstanding of the contract provisions.

1.6 QUALIFICATIONS OF BIDDERS

No proposal will be accepted from a Contractor who is not licensed under laws of California, as evidenced by the submittal of the Statement of Licensure. No award will be made to any bidder who cannot give satisfactory assurance to the District as to his own ability to carry out the contract, both from his financial standing and by reason of his previous experience as a Contractor on work of the nature contemplated in the contract. The bidder is required to submit his record of work of similar nature to that proposed under these specifications, and unfamiliarity with the type of work may be sufficient cause for rejection of a proposal.

A bid shall be rejected and a bidder shall be disqualified to bid on a District project if the bidder or any officer, manager, partner or shareholder of the bidder within the eighteen month period prior to the bid date shall have been an officer or employee of the District.

1.7 CONTRACTOR REGISTRATION

In accordance with the Labor Code (especially Sections 1725.5 and 1771.1), prior to submitting a proposal to District, all Contractors and Subcontractors must register as a "Public Works Contractor" with the Department of Industrial Relations (DIR) using the online application. Contractor's and Subcontractor's DIR Registration Number must be listed in the appropriate space on Contractor's Proposal form. This project is subject to compliance monitoring and enforcement by the DIR.

1.8 BALANCE BID

The Contractor is cautioned against unbalancing of its Bid by including its overhead and profit into one or two items only when there are a number of items on the schedule. The overhead and indirect charges should be prorated on all items in the schedule.

1.9 ANTI-DISCRIMINATION

It is the policy of the District that, in connection with all work performed under the Construction Agreement, there be no discrimination against any prospective or active employee engaged in the Work because of race, color, ancestry, national origin, religious creed, sex, age, marital status, or sexual preference. The Contractor agrees to comply with applicable Federal and California laws including, but not limited to, the California Fair Employment Practice Act, beginning with Labor Code Section 1410, and Labor Code Section 1735. In addition, the Contractor agrees to require like compliance by any subcontractors employed on the Work.

1.10 REQUIRED SUBMITTALS

There are a number of forms and other documents required as submittals by the Bidder during the various stages of the project. The following table provides a checklist of submittals required by the Bidder as requested in the Contract Documents. Bidders shall be made aware that the documents listed in the following table do not guarantee a complete submittal package.

	BID DOCUMENT	SUBMITTAL TIMEFRAME
<input type="checkbox"/>	Contractor's Proposal	with Bid Proposal
<input type="checkbox"/>	List of Subcontractors	with Bid Proposal
<input type="checkbox"/>	Experience Statement (Minimum of 5 References)	with Bid Proposal
<input type="checkbox"/>	Statement of Licensure	with Bid Proposal
<input type="checkbox"/>	Non-Collusion Declaration	with Bid Proposal
<input type="checkbox"/>	Iran Contracting Act Certification	with Bid Proposal
<input type="checkbox"/>	Bid Bond (10% of Contract Price)	with Bid Proposal
<input type="checkbox"/>	Construction Agreement	within 7 days of Notice of Intent to Award
<input type="checkbox"/>	Performance Bond (100% of Contract Price)	within 7 days of Notice of Intent to Award
<input type="checkbox"/>	Payment Bond (100% of Contract Price)	within 7 days of Notice of Intent to Award
<input type="checkbox"/>	Workers' Compensation Contractor Certificate	within 7 days of Notice of Intent to Award
<input type="checkbox"/>	Declaration of Sufficiency of Funds	within 7 days of Notice of Intent to Award
<input type="checkbox"/>	Certificates of Insurance	within 7 days of Notice of Intent to Award
<input type="checkbox"/>	Construction Schedule	within 14 days of Notice of Intent to Award
<input type="checkbox"/>	Affirmative Action Compliance Program (for Contractors with 50+ Employees)	within 30 days of Award of Contract

**ARTICLE 2
BIDDING PROCEDURES**

2.1 PROPOSAL FORMS

Attention of all bidders is called to all bid proposal forms attached hereto. Bidders are cautioned that all bid proposals submitted must be accompanied by all forms properly executed.

2.2 SUBMISSION OF BID PROPOSALS

All copies of the Contractor's Proposal, Bid Security, and other Bid Proposal Submittals shall be enclosed by the Bidder in a sealed opaque envelope. Said envelope, as well as any other, outer envelope or packaging in which said envelope may have been placed by Bidder or the carrier for delivery, shall be addressed and delivered as provided in the Notice Inviting Bids to Contractors.

2.3 TIMELY RECEIPT

The Bidder assumes full and sole responsibility for timely receipt of its Bid Proposal, including its Bid Security and all other Bid Submittals, at the location designated in the Notice Inviting Bids to Contractors.

2.4 DELIVERY METHOD OF BID PROPOSAL

Submittal of Bid Proposals shall be by hand delivery or mail, only. Oral, telephonic, telegraphic, facsimile or other electronic transmission is not permitted.

2.5 INVALID BID PROPOSALS

Bid Proposals submitted by fax or e-mail and those which fail to reach the place fixed for opening of Bid Proposals prior to the date and hour set for opening same will not be considered.

2.6 BID SECURITY:

Bid Security. Each Bid shall be accompanied by a Bid Security in the form of 1) cash, 2) a certified or cashier's check made payable to the Riverside County Flood Control and Water Conservation District, or 3) a Bid Bond (using the form of Bid Bond included in the Bidding Documents) issued by an Admitted Surety, in an amount equal to at least ten percent (10%) of the Bid Amount, as a guarantee that the Bidder, if awarded the Construction Contract, will enter into a Construction Contract with the District and furnish the Performance Bond, Payment Bond and other Post-Award Submittals required by the Bidding Documents. Should the Bidder refuse to enter into the Construction Contract or fail to furnish the Performance Bond, Payment Bond or any other Post-Award Submittals within the required timeframes as applicable, then the Bid Security shall be forfeited to the District in an amount equal to the difference between the amount of Bidder's Bid Amount and the amount for which the District may procure the work from another Bidder plus the costs to the District of redrafting, redrawing and republishing the Bidding Documents.

Retention by District. The District will have the right to retain the Bid Security of any Bidder to whom an Award is being considered until either (1) the Construction Contract has been executed and the Performance Bond, Payment Bond and other Post-Award Submittals have been furnished, or (2) all Bids have been rejected.

Return of Proposal Guarantees. Within ten (10) days after the award of the contract, the District will return the proposal guarantees accompanying such of the proposals as are not considered in making the award. All other proposal guarantees will be held until the contract has been fully executed, after which they will be returned to the respective bidders whose proposal they accompany.

2.7 SUBLETTING AND SUBCONTRACTING

Bidders are required, pursuant to the Subletting and Subcontracting Fair Practices Act (commencing with Section 4100 of the Public Contract Code) to list in their proposal the name and location of place of business of each subcontractor who will perform work or labor or render services in or about the construction of the work or improvement or a subcontractor who specially fabricates and installs a portion of the work or improvement according to detailed drawings contained in the Plans and Specifications, in excess of one-half ($\frac{1}{2}$) of one percent (1%) of the prime Contractor's total bid. Failure to list a subcontractor for a portion of the work means that the prime Contractor will do that portion of the work. Contractor shall list only one subcontractor for each portion as is defined by the Contractor in the Contractor's Bid Proposal.

2.8 DISCREPANCIES AND OMISSIONS

Discrepancies, omissions, ambiguities, or requirements likely to cause disputes between trades and similar matters shall be promptly brought to the attention of the Engineer. When appropriate, Addenda will be issued by the District. No communication by anyone as to such matters except by an Addendum affects the meaning or requirements of the Contract Documents.

2.9 ADDENDA

Interpretations, corrections, clarifications and changes to the Contract Documents will be made by Addenda. District reserves the right to issue Addenda to the Contract Documents at any time prior to the time set to open bids. Each potential bidder shall leave with the District its name and address for the purpose of receiving Addenda. District will cause copies of Addenda to be mailed or delivered to such names at such addresses. To be considered, a Contractor's proposal must list and take into account all issued Addenda.

Addenda will be transmitted by District to all prospective Bidders who (1) attended and signed in at the Mandatory Pre-Bid Site Review meeting (if any); (2) are plan holders; or (3) have submitted a written request to District for notice of Addenda at Riverside County Flood Control, 1995 Market Street, Riverside, CA 92501, including in such request the Bidder's name and address for mailing. Each potential Bidder shall leave with the District its name, address, email, and fax number for the purpose of receiving Addenda. To be considered, a Contractor's Proposal must list and take into account all issued Addenda. Failure of the Bidder to receive any Addendum shall not relieve the Bidder from any of its obligations under its Contractor's Proposal. The costs of performance by Bidder of all items of Work and other obligations contained in all Addenda issued by the District shall be deemed included in the amount of the

Contractor's Proposal. The Bidder shall identify and list in its Contractor's Proposal all Addenda received and included by the District as a basis for determining its Bid Proposal non-responsive.

2.10 **RESPONSE TO QUESTIONS**

Any questions or requests for information must be submitted in writing to the District attention:

Ryan Gosliga

Email: rgosliga@rivco.org

OR

Hard Copy: Riverside County Flood Control and Water Conservation District

1995 Market Street, Riverside, CA 92501

Attn: Ryan Gosliga

Questions or requests must be received **no later than 5:00 p.m. on Monday, June 15, 2020.**

2.11 **POSTPONEMENT**

The District reserves the right to postpone the time and date for the public opening of bids as specified in the Notice Inviting Bids to Contractors by issuance of an Addendum to the Contract Documents at any time prior to the specified time and date for public opening of bids.

2.12 **REJECTION OF BID PROPOSALS CONTAINING ALTERATIONS, ERASURES OR IRREGULARITIES**

Bid Proposals may be rejected if they show any alterations of form, additions not called for, conditional Bid Proposals, incomplete Bid Proposals, erasures, or irregularities of any kind. Erasures or interlineations in the Bid Proposal must be explained or noted over the signature of the Bidder. The District may determine as unresponsive any Bid Proposal in which any statement or representation made or incorporated by reference in the Contractor's Proposal, including any Bid submittal comprising the Bid Proposal, is false, incorrect or materially incomplete and misleading.

2.13 **DISQUALIFICATION OF BIDDERS**

More than one proposal from an individual, a firm or partnership, a corporation or an association under the same or different names will not be considered. Reasonable ground for believing that any bidder is interested in more than one proposal for the work contemplated will cause the rejection of all proposals in which such bidder is interested. If there is any reason for believing that collusion exists among the bidders, none of the participants in such collusion will be considered in awarding the contract. Proposals in which the prices obviously are unbalanced may be rejected.

2.14 **WITHDRAWAL OF PROPOSALS**

Any proposal may be withdrawn at any time prior to the hour fixed in the Notice to Contractors for the opening of proposals, provided that a request in writing, executed by the bidder or his duly authorized representative, for the withdrawal of such proposal, is filed with the Chief Engineer. The withdrawal of a proposal shall not prejudice the right of a bidder to file a new proposal.

2.15 IRAN CONTRACTING ACT

In accordance with Public Contract Code Section 2204(a), prior to bidding on, submitting a proposal or executing a contract or renewal for a District contract for goods or services of \$1,000,000 or more, a Contractor must either:

- a) Certify it is not on the current list of persons engaged in investment activities in Iran created by the California Department of General Services ("DGS") pursuant to Public Contract Code Section 2203(b) and is not a financial institution extending twenty million dollars (\$20,000,000) or more in credit to another person, for 45 days or more, if that other person will use the credit to provide goods or services in the energy sector in Iran and is identified on the current list of persons engaged in investment activities in Iran created by DGS; or
- b) Demonstrate it has been exempted from the certification requirement for that solicitation or contract pursuant to Public Contract Code Section 2203(c) or (d).

To comply with this requirement, please insert your Contractor or financial institution name and Federal ID Number (if available) and complete one of the options on Page XXII. Please note: California law establishes penalties for providing false certifications, including civil penalties equal to the greater of \$250,000 or twice the amount of the contract for which the false certification was made; contract termination; and three-year ineligibility to bid on contracts. (Public Contract Code section 2205.)

2.16 PUBLIC OPENING OF PROPOSALS

Proposals will be opened and read publicly at the time and place indicated in the Notice Inviting Bids to Contractors. Bidders or their authorized agents are invited to be present.

ARTICLE 3 CONSIDERATION OF BIDS

3.1 BASIS OF AWARD

The award of the Contract, if it be awarded, will be to the lowest responsible and qualified Bidder based upon all Bid items.

3.2 NOTICE OF INTENT TO AWARD

Within thirty (30) days following public opening and reading of Bids, the District will issue a Notice of Intent to Award identifying the name of the Bidder to whom the District intends to Award the Construction Contract. Such notice will be posted under Public Notices at rcflood.org. The District may, in its sole and absolute discretion, elect to extend the time for its issuance of its Notice of Intent to Award.

3.3 BID PROTESTS

Any Bidder submitting a Bid Proposal to the District may file a protest of the District's proposed Award of the Construction Contract provided that each and all of the following are complied with:

1. The bid protest is in writing.

- X -

2. The bid protest is both: (1) filed with and received by David Garcia at the following address, 1995 Market Street, Riverside, California, not more than five (5) days following the date of issuance of the Notice of Intent to Award. Failure to timely file and serve the bid protest as afore stated shall constitute grounds for the District's denial of the bid protest without consideration of the grounds stated therein.
3. The written bid protest sets forth, in detail, all grounds for the bid protest, including without limitation all facts, supporting documentation, legal authorities and argument in support of the grounds for the bid protest. Any grounds not set forth in the bid protest shall be deemed waived. All factual contentions must be supported by competent, admissible and credible evidence. Any bid protest not conforming to the foregoing shall be rejected as invalid.
4. Provided that a bid protest is filed in conformity with the foregoing, the General Manager-Chief Engineer, or such individual(s) as may be designated by the General Manager-Chief Engineer in his/her discretion, shall review and evaluate the basis of the bid protest, and shall provide a written decision to the Bidder submitting the bid protest, either concurring with or denying the bid protest. The written decision of the General Manager-Chief Engineer or his/her designee shall be final, unless overturned by the Board of Supervisors.
5. An inadvertent error in listing the California contractor license number or DIR public works contractor registration number for a subcontractor shall not be grounds for filing a bid protest or grounds for considering the bid nonresponsive if the corrected number is submitted to the District within 24 hours after the bid opening and provided the corrected number corresponds to the submitted name and location for that subcontractor.

3.4 AWARD OF CONTRACT

The right is reserved to reject any and all proposals and to waive technical defects as the best interests of the District may require. The award of the Contract, if it be awarded, will be to the lowest responsible bidder whose proposal complies with the requirements prescribed. The award, if made, will be made within sixty (60) days after the opening of the proposals. All proposals will be compared on the basis of the Engineer's estimate of the quantities of work to be done.

ARTICLE 4 POST-NOTICE OF INTENT TO AWARD

4.1 POST-NOTICE OF INTENT TO AWARD SUBMITTALS

Within the time periods set forth below, the successful Bidder identified in the Notice of Intent to Award as the successful Bidder shall submit the following additional Post-Notice of Intent to Award submittals, completed and signed in the manner required by the Contract Documents, to the District at 1995 Market Street, Riverside, California 92501:

- 4.1.1 Within **seven (7) days** after issuance by District to Bidder of the Notice of Intent to Award and prior to contract award, such Bidder shall submit to the District the following:

- (1) Construction Agreement duly executed by the authorized delegate of the Contractor;
- (2) Performance Bond and Payment Bond (issued by Surety), as set forth in Section 4.2 below;
- (3) Evidence of Insurance, as specified by the Contract Documents;
- (4) Workers' Compensation Certificate, in the form specified by the Contract Documents; and
- (5) Declaration of Sufficiency of Funds (required only if the Bidder has not entered into a collective bargaining agreement covering the workers to be employed for performance of the Work), in the form specified by the Contract Documents.

4.1.2 Within **fourteen (14) days** after issuance by District to Bidder of the Notice of Intent to Award and prior to commencement of the Work, such Bidder shall submit to the District the following:

- (1) Construction Schedule, prepared by Bidder in the manner required by Section 2.02 of the General Provisions; and
- (2) Schedule of Values, prepared by Bidder in the manner required by the Specifications and Contract Documents.

4.2 **CONTRACT SECURITY – PERFORMANCE BOND AND PAYMENT BOND**

The Contractor shall furnish two (2) surety bonds, each in quadruplicate, one as a security for the faithful performance of the contract in the amount equal to one hundred percent (100%) of the contract price, and one as security for the payment of all persons performing labor and furnishing materials in connection with the contract in an amount equal to one hundred percent (100%) of the Contract Price. The penal sums of the Performance Bond and Payment Bond shall each be initially in the amount of one hundred percent (100%) of the Contract Price. The penal sum may be required to be increased for Contract Adjustments increasing the Contract Price that are authorized by Change Order. All bonds must be submitted on forms provided by the District. Bonds submitted in any other form will not be accepted.

Prior to the execution of the Contract, the Contractor shall furnish to the District the required, original, Performance and Payment Bonds, issued by an admitted surety and shall have a A.M. Best's Insurance Rating of A VIII (A:8) or better rated surety company, authorized to do business in the State of California. The Bonds shall be executed by an authorized attorney-in-fact for the Surety company and his/her original or certified copy Power of Attorney must be attached to the Bonds. Premiums for Bonds shall be paid by the Contractor. Notary acknowledgements of the signatures of the Contractor and Surety(ies) is required. The attorney-in-fact who executes the required Performance Bond and Payment Bond on behalf of the Surety shall affix thereto a certified and current copy of the Power of Attorney authorizing such attorney-in-fact to execute same on behalf of such Surety. Should any Surety on the Performance Bond or Payment Bond be deemed unsatisfactory by the District, Contractor shall upon notice promptly substitute new bonds satisfactory to the District.

If the Performance Bond provides for a one-year warranty, a separate Maintenance Bond is not necessary. If the warranty period specified in the contract is for longer than one year, a Maintenance Bond equal to ten percent (10%) of the contract price is required. Bonds shall be duly executed by a responsible corporate surety, authorized to issue such bonds in the State of California and secured through an authorized agent with an office in California.

4.3 FORFEITURE FOR FAILURE TO POST SECURITY AND EXECUTE AGREEMENT

In the event the Bidder, to whom an award will be made, fails or refuses to post the required bonds and provide the required certificates of insurance and fails to return executed copies of the Construction Agreement within seven (7) days after the prescribed forms are presented to it for signature, the District may declare the Bidder's Bid deposit or bond forfeited as damages caused by the failure of the Bidder to post such security and execute such copies of the Construction Agreement and may award the Work to the next lowest responsible Bidder, or may call for new bids.

CONTRACTOR'S PROPOSAL

TO THE BOARD OF SUPERVISORS OF THE RIVERSIDE COUNTY FLOOD CONTROL AND WATER CONSERVATION DISTRICT:

The undersigned hereby declare(s):

- (a) That the only persons or parties interested in this proposal as principals are the following:

Name of Company (and dba if applicable) ("Contractor"): Sukut Construction, LLC

(If the Contractor is a corporation, give the name of the corporation and the name of its president, secretary, treasurer, and manager. If a copartnership, give the name under which the copartnership does business, and the names and addresses of all copartners. If an individual, state the name and address under which the contract is to be drawn.)

- (b) That this proposal is made without collusion with any other person, firm or corporation.
- (c) That he has carefully examined the location of the proposed work, and has familiarized himself with all of the physical and climatic conditions, and makes his proposal solely upon his own knowledge.
- (d) That he has carefully examined the attached specifications as referred to, and the plans, and makes this proposal in accordance therewith.
- (e) That, if this proposal is accepted, he will enter into a written contract with the Riverside County Flood Control and Water Conservation District, Riverside, State of California.
- (f) That he proposes to enter into such contract and to accept in full payment for the work actually done thereunder the prices shown in the attached schedule. It is understood and agreed that the quantities set forth are but estimates, and that the unit prices will apply to the actual quantities whatever they may be, subject to such adjustments and alterations as elsewhere provided for in the Contract Documents.

As bid security, accompanying this proposal is a certified or cashier's check or bid bond payable to the order of the Riverside County Flood Control and Water Conservation District, Riverside, California, in the sum of

TEN PERCENT OF TOTAL BID PRICE Dollars (\$ 10%)

**THE REQUIRED REFERENCES AND OTHER REQUIRED DOCUMENTS
MUST BE ATTACHED TO THIS BID PROPOSAL**

It is understood and agreed that should the Contractor within seven (7) days after the prescribed forms are presented to him for signature fail to return the contract and furnish acceptable surety bond and insurance, then, at the discretion of the District, the proceeds of said check shall become the property of the District, the Contractor shall be found in default and the project may be awarded to another contractor. The bid bond or check shall be held subject to payment to the District of the difference in money between the amount of the contract with another party to perform the work, together with the cost to the District of redrafting, redrawing and publishing documents and papers necessary to obtain new bids on said work. The bid bond or check shall, in addition, be held subject to all other actual damages suffered by the District. But if the contract is entered into and said bonds and insurance are furnished, or if the proposal is not accepted, then the said check shall be returned to the undersigned.

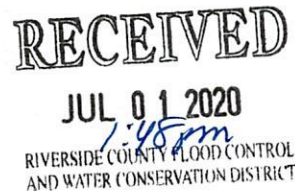

PROPOSAL

For the Construction of **Palm Canyon Wash, Stage 93 Emergency Levee Restoration**, located in the city of Palm Springs, Riverside County, consisting of the following estimated quantities:

SECT. NO.	ITEM NO.	ITEM OF WORK	UNIT	QUANTITY	UNIT COST	TOTAL COST
10	1.	Mobilization	L.S.	---	---	351,783
11	2.	Water Control	L.S.	---	---	2,500
13	3.	Clearing and Miscellaneous Work	L.S.	---	---	25,000
14	4.	Excavation	C.Y.	72,000	2.60	187,200
14	5.	Backfill	C.Y.	61,500	1.95	119,925
14	6.	Embankment	C.Y.	10,500	2.00	21,000
15	7.	Trench Safety System	L.S.	---	---	1,500
16	8.	Class "A" Concrete, Slope Paving	C.Y.	1,750	\$ 450	787,500
16	9.	Class "B" Concrete, 2' Cutoff Wall	L.F.	1,455	17	24,735
16	10.	Class "B" Concrete, 4' Cutoff Wall	L.F.	130	80	10,400
20	11.	Remove and Reinstall Fence	L.F.	200	61	12,200
20	12.	Remove and Reinstall Gate	EACH	3	4,000	12,000
21	13.	Existing Riprap Removal, Temporary Stockpiling and Final Placement	L.S.	---	---	18,000
21	14.	Air-Blasting	L.S.	---	---	6,000
21	15.	Existing 4" Unreinforced Concrete Slope Paneling Breaking and Removal, Temporary Stockpiling and Final Placement	L.S.	---	---	28,500
21	16.	Toe Extension Epoxy	L.F.	2,000	9.00 ^{5.25}	18,000 ^{10,500} MG
21	17.	Perimeter Demarcation Fencing	L.F.	4,000	3.45	13,800
21	18.	Extra Directed Work	L.S.	---	---	150,000.00
27	19.	Dust Abatement	L.S.	---	---	19,000

PROPOSAL contd.

SECT. NO.	ITEM NO.	ITEM OF WORK	UNIT	QUANTITY	UNIT COST	TOTAL COST
29	20.	Stormwater and Non-Stormwater Pollution Control	L.S.	---	---	58,000
29	21.	Non-Stormwater Discharge or Dewatering	L.S.	---	---	17,000

For the Total Bid Proposal of: **TOTAL COST**
(State in Figures) \$ 1,876,543

Sukut Construction, LLC
Name of Contractor

4010 W. Chandler Avenue
Address

Santa Ana, CA 92704
City, State, Zip

714.540.5351 714.545.2003
Telephone Number Fax Number

estimating@sukut.com
Email

Dated: 7/1/2020

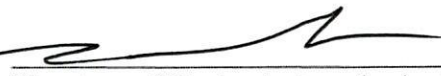
Signature of Contractor's authorized representative

Name: Michael Greenlee

Title: Vice President / Chief Estimator

37-1702665
S.S.N. or E.I.N.

985106 A, B, & HAZ
Contractor's License No. and Classification

1000001133
Contractor's DIR Registration No.

If bidder is a corporation, corporate seal and attestation shall be provided below.

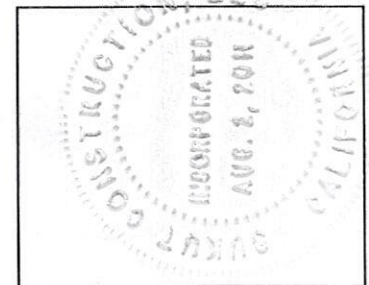

ADDENDUM NO. 1 ACKNOWLEDGED

Signature

LIST OF SUBCONTRACTORS

Contractor Sukut Construction, LLC

Palm Canyon Wash, Stage 93
Emergency Levee Restoration
6-0-00040-93

Give the name and the location of the place of business of each Subcontractor who will perform work or labor or render service to the General Contractor in or about the construction of the work or improvement, or a Subcontractor who specially fabricates and installs a portion of the work or improvement, in an amount in excess of one-half (½) of one percent (1%) of the General Contractor's total bid. List the bid item numbers of the work each subcontractor will do. If a portion of an item is to be subcontracted, show what percentage of that item is to be subcontracted.

Item No. (s) 11 0 12

Name of Subcontractor Alcorn Fence Company

Address/City/Phone 6445 Old Padley Rd, Riverside, CA 951.685.5871

License No. 122954 Subcontractor's DIR Registration No. 1000001986

Item No. (s) 8, 9, 10

Name of Subcontractor Pacific Steel Group

Address/City/Phone 4805 Murphy Canyon Rd., San Diego, 858.251.100

License No. 997880 Subcontractor's DIR Registration No. 1000004101

Item No. (s) _____

Name of Subcontractor _____

Address/City/Phone _____

License No. _____ Subcontractor's DIR Registration No. _____

Item No. (s) _____

Name of Subcontractor _____

Address/City/Phone _____

License No. _____ Subcontractor's DIR Registration No. _____

Item No. (s) _____

Name of Subcontractor _____

Address/City/Phone _____

License No. _____ Subcontractor's DIR Registration No. _____

EXPERIENCE STATEMENT

Bidder submits, as part of his bid, the following statements as to his experience qualifications. Bidder certifies that all statements and information set forth below are true and accurate. Bidder hereby authorizes the District to make inquiry as appropriate regarding his experience.

Bidder has been engaged in the contracting business under this present business name for Nine years. Nine years as Sukut Construction, LLC and Forty-two years as Sukut Construction, Inc.

Bidder's experience in work of a nature similar in type and magnitude to that set forth in the Specification extends over a period of Fifty-one years.

Within the last three years, Bidder has satisfactorily completed the following contracts covering work similar in type and magnitude to that set forth in these Specifications for the following owners (name person, firms, or authorities):

Name and Address of Owner/Agency	Representative and Telephone	Type of Work, Year Completed and Dollar Amount
County of Orange Public Works Dept. <u>1152 East Fruit St., Bldg. #4, Santa Ana, CA 92701</u>	Kevin Tran, R.E., Greenville-Banning Channel, <u>(714) 245-4500</u>	Channel Work, 2/2017 <u>\$5,811,597</u>
Orange County Public Works Dept. <u>1152 East Fruit St., Bldg. #4, Santa Ana, CA 92701</u>	Octavio Rivas, P.E. <u>(714) 245-4520</u>	La Pata Ave. Gap Closure, Roadway/Bridge, 7/2018 <u>\$86,097,000</u>
Riverside County Flood Control and Water Res. Dist. <u>1995 Market St., Riverside, CA 92501</u>	David Garcia <u>(951) 315-0730</u>	Heacock Channel Stages 3 & 4, Concrete Channel, 9/2019 <u>\$13,278,623</u>
Orange County Waste & Recycling <u>300 N. Flower St., Santa Ana, CA 92703</u>	Kevin Hanson, P.M., FRB Groundwater Projection Sys. <u>(949) 279-8483</u>	Phs 8B-2, 10/2019 <u>\$26,048,844.44</u>
San Francisco Public Utilities Commission <u>1155 Market St., 9th Fl., San Francisco, CA 94103</u>	Susan Hou, Sr. P. M., Calaveras Dam Replacement, <u>(925) 862-1294</u>	Dam Construction, 5/2019 <u>\$574,000,000</u>
County of Riverside Transportation, Eric Lohr, Principle Constr. Inspector <u>3525 14th St., 2nd Fl., Riverside, CA 92501</u>	Clinton Keith Road Extension, <u>(951) 961-6191</u>	Roadway, 9/2018 <u>\$30,828,593</u>

STATEMENT OF LICENSURE

Pursuant to California Public Contract Code §3300, the undersigned does certify as follows:

1. That the pocket license/certificate of licensure I have presented to owner as of this date is my own license, being State of California, Contractors License No. 985106 ; and

2. That said Contractors License is current and valid; and

3. That said Contractors License is of a classification appropriate to the work to be undertaken for owner, a Class ^{A, B,}_{HAZ} license.

I declare under penalty of perjury under the laws of the State of California that the foregoing is true and correct.

DATED: 7/01/2020



Signature

Michael Greenlee, V.P./Chief Estimator

Title

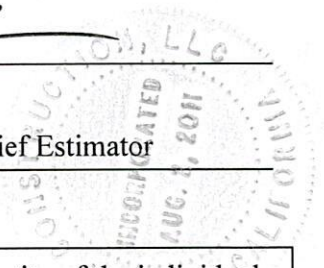

A notary public or other officer completing this certificate verifies only the identity of the individual who signed the document to which this certificate is attached, and not the truthfulness, accuracy, or validity of that document.

STATE OF CALIFORNIA) §
COUNTY OF ORANGE)

On this the 1st day of July, 2020, before me
Jami Collins

the undersigned Notary Public, personally appeared
Michael Greenlee

who proved to me on the basis of satisfactory evidence to be the person(s) whose name(s) is/are subscribed to the within instrument, and acknowledged that he/she executed the same in his/her/their authorized capacity(ies), and that by his/her/their signature(s) on the instrument the person(s), or the entity upon behalf of which the person(s) acted, executed the instrument.

I certify under PENALTY OF PERJURY under the laws of the State of California that the foregoing paragraph is true and correct.

WITNESS my hand and official seal.

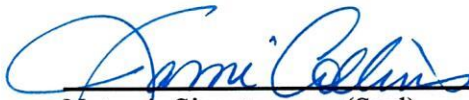

Notary's Signature (Seal)

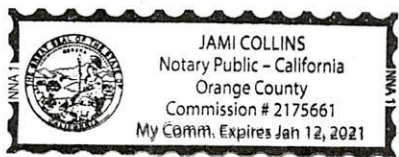

NON-COLLUSION DECLARATION
(Public Contract Code Section 7106)

The undersigned declares:

I am the Vice President/Chief Estimator of Sukut Construction, LLC, the party making the foregoing bid.

The bid is not made in the interest of, or on behalf of, any undisclosed person, partnership, company, association, organization, or corporation. The bid is genuine and not collusive or sham. The bidder has not directly or indirectly induced or solicited any other bidder to put in a false or sham bid. The bidder has not directly or indirectly colluded, conspired, connived, or agreed with any bidder or anyone else to put in a sham bid, or to refrain from bidding. The bidder has not in any manner, directly or indirectly, sought by agreement, communication, or conference with anyone to fix the bid price of the bidder or any other bidder, or to fix any overhead, profit, or cost element of the bid price, or of that of any other bidder. All statements contained in the bid are true. The bidder has not, directly or indirectly, submitted his or her bid price or any breakdown thereof, or the contents thereof, or divulged information or data relative thereto, to any corporation, partnership, company, association, organization, bid depository, or to any member or agent thereof, to effectuate a collusive or sham bid, and has not paid, and will not pay, any person or entity for such purpose.

Any person executing this declaration on behalf of a bidder that is a corporation, partnership, joint venture, limited liability company, limited liability partnership, or any other entity, hereby represents that he or she has full power to execute, and does execute, this declaration on behalf of the bidder.

I declare under penalty of perjury under the laws of the State of California that the foregoing is true and correct and that this declaration is executed on July 01, 2020 [date], at Santa Ana [city], CA [state].

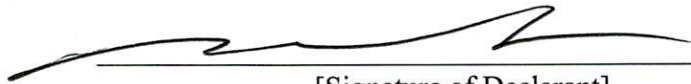

[Signature of Declarant]

Michael Greenlee

[Printed Name of Person Signing]

Sukut Construction, LLC

[Name of Bidder]

Vice President/Chief Estimator

[Office or Title]

IRAN CONTRACTING ACT CERTIFICATION

In accordance with Public Contract Code Section 2204(a), prior to bidding on, submitting a proposal or executing a contract or renewal for a District contract for goods or services of \$1,000,000 or more, a Contractor must either:

- c) Certify it is not on the current list of persons engaged in investment activities in Iran created by the California Department of General Services ("DGS") pursuant to Public Contract Code Section 2203(b) and is not a financial institution extending twenty million dollars (\$20,000,000) or more in credit to another person, for 45 days or more, if that other person will use the credit to provide goods or services in the energy sector in Iran and is identified on the current list of persons engaged in investment activities in Iran created by DGS; or
- d) Demonstrate it has been exempted from the certification requirement for that solicitation or contract pursuant to Public Contract Code Section 2203(c) or (d).

To comply with this requirement, please insert your Contractor or financial institution name and Federal ID Number (if available) and complete one of the options below. Please note: California law establishes penalties for providing false certifications, including civil penalties equal to the greater of \$250,000 or twice the amount of the contract for which the false certification was made; contract termination; and three-year ineligibility to bid on contracts. (Public Contract Code Section 2205.)

Option #1 – Certification

I, the official named below, certify I am duly authorized to execute this certification on behalf of the Contractor/financial institution identified below, and the Contractor/financial institution identified below is **not** on the current list of persons engaged in investment activities in Iran created by DGS and is not a financial institution extending twenty million dollars (\$20,000,000) or more in credit to another person/vendor, for 45 days or more, if that other person/vendor will use the credit to provide goods or services in the energy sector in Iran and is identified on the current list of persons engaged in investment activities in Iran created by DGS.

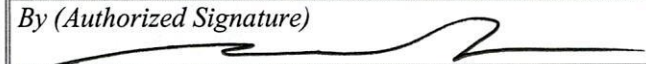
<i>Contractor Name/Financial Institution (Printed)</i> Sukut Construction, LLC		<i>Federal ID Number (or n/a)</i> 37-1702665
<i>By (Authorized Signature)</i> 		
<i>Printed Name and Title of Person Signing</i> Michael Greenlee, VP/Chief Estimator		
<i>Date Executed</i> 07/01/2020	<i>Executed in</i> Santa Ana, CA	

Option #2 – Exemption

Pursuant to Public Contract Code Sections 2203(c) and (d), a public entity may permit a Contractor/financial institution engaged in investment activities in Iran, on a case-by-case basis, to be eligible for, or to bid on, submit a proposal for, or enters into or renews, a contract for goods and services.

If you have obtained an exemption from the certification requirement under the Iran Contracting Act, please fill out the information below, and attach documentation demonstrating the exemption approval.

<i>Contractor Name/Financial Institution (Printed)</i>		<i>Federal ID Number (or n/a)</i>
<i>By (Authorized Signature)</i>		
<i>Printed Name and Title of Person Signing</i>		
<i>Date Executed</i>	<i>Executed in</i>	

BID BOND

Page 1 of 2

Recitals

1. The undersigned Sukut Construction, LLC (Contractor), is herewith submitting to the Riverside County Flood Control and Water Conservation District (District), a Bid Proposal ("Proposal") dated June 24, 2020, for the construction of public work for **Palm Canyon Wash, Stage 93 Emergency Levee Restoration** in accordance with a Notice to Contractors dated May 19, 2020.
2. Contractor is obligated as a condition of said Bid to submit security in the amount of at least ten percent (10%) of the Bid Amount, which security may be in the form of a Bid Bond issued by an admitted surety insurer pursuant to Code of Civil Procedure Section 995.120 ("Admitted Surety").
3. Liberty Mutual Insurance Company a Massachusetts corporation, hereafter called (Surety), is the surety on this Bid Bond.

Agreement

We, Contractor as principal and Surety as surety, jointly and severally agree and state as follows:

1. The amount of the obligation of this Bond is ten percent (10%) of the amount of the Contractor's Proposal and inures to the benefit of District.
2. This Bond is exonerated by (1) District rejecting said Proposal or, in the alternate, (2) if said Proposal is accepted, Contractor executes the Construction Agreement and furnishes the Performance Bond, Payment Bond and Insurance as agreed to in its Proposal, otherwise it remains in full force and effect for the recovery of loss, damage and expense of District resulting from failure of Contractor to act as agreed to in its Proposal. Some types of possible loss, damage and expense are specified in the Contractor's Proposal.
3. Surety for value received, stipulates and agrees that its obligations hereunder that no change, any extension of time within which District may accept the Proposal, alteration or addition to the terms of the Contract or the Bidding Documents, or to the work to be performed thereunder, nor any withdrawal of the Proposal in a manner not permitted by the requirements of the Bidding requirements shall in any way impair or affect Surety's obligation under this Bond, and Surety does hereby waive notice of any such changes, extension of time, alterations or additions.
4. This Bond is binding on our heirs, executors, administrators, successors and assigns.
5. In the event any legal proceeding or arbitration is brought upon this Bond by District and judgment or award is entered in favor of District as the prevailing party, Surety shall pay all costs and attorney's fees incurred by the District.

BID BOND

Page 2 of 2

IN WITNESS WHEREOF the undersigned parties have executed this instrument under their several seals this day of June 15, 2020, the name and corporate seal of each corporate party being hereto affixed and these presents duly signed by its undersigned representative, pursuant to authority of its governing body.

Dated: June 15, 2020

Sukut Construction, LLC
(Proper name of Contractor)

(Corporate Seal of Contractor,
if Corporation)

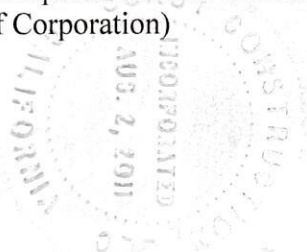

By: [Signature]
Signature of Contractor's authorized representative

Print or type authorized representative's Name and Title

4010 West Chandler Avenue, Santa Ana, CA 92704
Print or type Contractor's Address

(Corporate Seal of Surety)

Liberty Mutual Insurance Company
Surety

By: [Signature]
Attorney-in-Fact Kim Luu

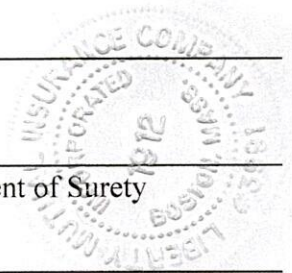

(Attach Attorney-in-Fact
Certificate and Required
Acknowledgments)

Alliant Insurance Services, Inc.
Name and Address of California Agent of Surety

1301 Dove Street, Suite 200

Newport Beach, CA 92660

(949) 756-0271
Telephone Number of California Agent of Surety

NOTE: Notary acknowledgment of signatures of Contractor and Surety, and Surety's Power of Attorney, must be included or attached.

CALIFORNIA ALL-PURPOSE ACKNOWLEDGMENT

CIVIL CODE § 1189

A notary public or other officer completing this certificate verifies only the identity of the individual who signed the document to which this certificate is attached, and not the truthfulness, accuracy, or validity of that document.

State of California)
County of Orange)

On JUN 15 2020 before me, Reece Joel Diaz, Notary Public
Date Here Insert Name and Title of the Officer
personally appeared Kim Luu
Name(s) of Signer(s)

who proved to me on the basis of satisfactory evidence to be the person(s) whose name(s) is/are subscribed to the within instrument and acknowledged to me that he/she/they executed the same in his/her/their authorized capacity(ies), and that by his/her/their signature(s) on the instrument the person(s), or the entity upon behalf of which the person(s) acted, executed the instrument.

I certify under PENALTY OF PERJURY under the laws of the State of California that the foregoing paragraph is true and correct.

WITNESS my hand and official seal.

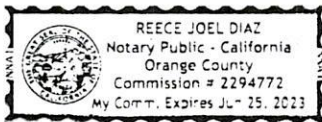

Signature [Handwritten Signature]
Signature of Notary Public

Place Notary Seal Above

OPTIONAL

Though this section is optional, completing this information can deter alteration of the document or fraudulent reattachment of this form to an unintended document.

Description of Attached Document

Title or Type of Document: _____ Document Date: _____
Number of Pages: _____ Signer(s) Other Than Named Above: _____

Capacity(ies) Claimed by Signer(s)

Signer's Name: _____
 Corporate Officer — Title(s): _____
 Partner — Limited General
 Individual Attorney in Fact
 Trustee Guardian or Conservator
 Other: _____
Signer Is Representing: _____

Signer's Name: _____
 Corporate Officer — Title(s): _____
 Partner — Limited General
 Individual Attorney in Fact
 Trustee Guardian or Conservator
 Other: _____
Signer Is Representing: _____

CALIFORNIA ALL-PURPOSE ACKNOWLEDGMENT

CIVIL CODE § 1189

A notary public or other officer completing this certificate verifies only the identity of the individual who signed the document to which this certificate is attached, and not the truthfulness, accuracy, or validity of that document.

State of California)
County of Orange)

On July 1, 2020 before me, Jami Collins, Notary Public,
Date Here Insert Name and Title of the Officer

personally appeared Michael Greenlee
Name(s) of Signer(s)

who proved to me on the basis of satisfactory evidence to be the person(s) whose name(s) is/are subscribed to the within instrument and acknowledged to me that he/she/they executed the same in his/her/their authorized capacity(ies), and that by his/her/their signature(s) on the instrument the person(s), or the entity upon behalf of which the person(s) acted, executed the instrument.

I certify under PENALTY OF PERJURY under the laws of the State of California that the foregoing paragraph is true and correct.

WITNESS my hand and official seal.

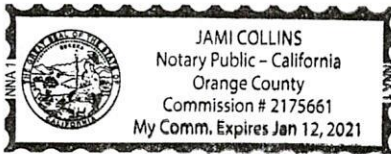

Signature Jami Collins
Signature of Notary Public

Place Notary Seal Above

OPTIONAL

Though this section is optional, completing this information can deter alteration of the document or fraudulent reattachment of this form to an unintended document.

Description of Attached Document

Title or Type of Document: _____ Document Date: _____

Number of Pages: _____ Signer(s) Other Than Named Above: _____

Capacity(ies) Claimed by Signer(s)

Signer's Name: _____

Corporate Officer — Title(s): _____

Partner — Limited General

Individual Attorney in Fact

Trustee Guardian or Conservator

Other: _____

Signer Is Representing: _____

Signer's Name: _____

Corporate Officer — Title(s): _____

Partner — Limited General

Individual Attorney in Fact

Trustee Guardian or Conservator

Other: _____

Signer Is Representing: _____



This Power of Attorney limits the acts of those named herein, and they have no authority to bind the Company except in the manner and to the extent herein stated.

Liberty Mutual Insurance Company
The Ohio Casualty Insurance Company
West American Insurance Company

Certificate No: 8201964-977460

POWER OF ATTORNEY

KNOWN ALL PERSONS BY THESE PRESENTS: That The Ohio Casualty Insurance Company is a corporation duly organized under the laws of the State of New Hampshire, that Liberty Mutual Insurance Company is a corporation duly organized under the laws of the State of Massachusetts, and West American Insurance Company is a corporation duly organized under the laws of the State of Indiana (herein collectively called the "Companies"), pursuant to and by authority herein set forth, does hereby name, constitute and appoint, Rhonda C. Abel; Jeri Apodaca; Reece Joel Diaz; Maria Guise; Kim Luu; Michael D. Parizino; Rachelle Rheault; Heather Saltarelli; James A. Schaller

all of the city of Newport Beach state of California each individually if there be more than one named, its true and lawful attorney-in-fact to make, execute, seal, acknowledge and deliver, for and on its behalf as surety and as its act and deed, any and all undertakings, bonds, recognizances and other surety obligations, in pursuance of these presents and shall be as binding upon the Companies as if they have been duly signed by the president and attested by the secretary of the Companies in their own proper persons.

IN WITNESS WHEREOF, this Power of Attorney has been subscribed by an authorized officer or official of the Companies and the corporate seals of the Companies have been affixed thereto this 23rd day of August, 2019.



Liberty Mutual Insurance Company
The Ohio Casualty Insurance Company
West American Insurance Company

By: [Signature]
David M. Carey, Assistant Secretary

State of PENNSYLVANIA
County of MONTGOMERY ss

On this 23rd day of August, 2019 before me personally appeared David M. Carey, who acknowledged himself to be the Assistant Secretary of Liberty Mutual Insurance Company, The Ohio Casualty Company, and West American Insurance Company, and that he, as such, being authorized so to do, execute the foregoing instrument for the purposes therein contained by signing on behalf of the corporations by himself as a duly authorized officer.

IN WITNESS WHEREOF, I have hereunto subscribed my name and affixed my notarial seal at King of Prussia, Pennsylvania, on the day and year first above written.



COMMONWEALTH OF PENNSYLVANIA
Notarial Seal
Teresa Pastella, Notary Public
Upper Merion Twp., Montgomery County
My Commission Expires March 28, 2021
Member, Pennsylvania Association of Notaries

By: [Signature]
Teresa Pastella, Notary Public

This Power of Attorney is made and executed pursuant to and by authority of the following By-laws and Authorizations of The Ohio Casualty Insurance Company, Liberty Mutual Insurance Company, and West American Insurance Company which resolutions are now in full force and effect reading as follows:

ARTICLE IV - OFFICERS: Section 12. Power of Attorney.
Any officer or other official of the Corporation authorized for that purpose in writing by the Chairman or the President, and subject to such limitation as the Chairman or the President may prescribe, shall appoint such attorneys-in-fact, as may be necessary to act in behalf of the Corporation to make, execute, seal, acknowledge and deliver as surety any and all undertakings, bonds, recognizances and other surety obligations. Such attorneys-in-fact, subject to the limitations set forth in their respective powers of attorney, shall have full power to bind the Corporation by their signature and execution of any such instruments and to attach thereto the seal of the Corporation. When so executed, such instruments shall be as binding as if signed by the President and attested to by the Secretary. Any power or authority granted to any representative or attorney-in-fact under the provisions of this article may be revoked at any time by the Board, the Chairman, the President or by the officer or officers granting such power or authority.

ARTICLE XIII - Execution of Contracts: Section 5. Surety Bonds and Undertakings.
Any officer of the Company authorized for that purpose in writing by the chairman or the president, and subject to such limitations as the chairman or the president may prescribe, shall appoint such attorneys-in-fact, as may be necessary to act in behalf of the Company to make, execute, seal, acknowledge and deliver as surety any and all undertakings, bonds, recognizances and other surety obligations. Such attorneys-in-fact subject to the limitations set forth in their respective powers of attorney, shall have full power to bind the Company by their signature and execution of any such instruments and to attach thereto the seal of the Company. When so executed such instruments shall be as binding as if signed by the president and attested by the secretary.

Certificate of Designation - The President of the Company, acting pursuant to the Bylaws of the Company, authorizes David M. Carey, Assistant Secretary to appoint such attorneys-in-fact as may be necessary to act on behalf of the Company to make, execute, seal, acknowledge and deliver as surety any and all undertakings, bonds, recognizances and other surety obligations.

Authorization - By unanimous consent of the Company's Board of Directors, the Company consents that facsimile or mechanically reproduced signature of any assistant secretary of the Company, wherever appearing upon a certified copy of any power of attorney issued by the Company in connection with surety bonds, shall be valid and binding upon the Company with the same force and effect as though manually affixed.

I, Renee C. Llewellyn, the undersigned, Assistant Secretary, The Ohio Casualty Insurance Company, Liberty Mutual Insurance Company, and West American Insurance Company do hereby certify that the original power of attorney of which the foregoing is a full, true and correct copy of the Power of Attorney executed by said Companies, is in full force and effect and has not been revoked.

IN TESTIMONY WHEREOF, I have hereunto set my hand and affixed the seals of said Companies this 15th day of June, 2020.



By: [Signature]
Renee C. Llewellyn, Assistant Secretary

Not valid for mortgage, note, loan, letter of credit, currency rate, interest rate or residual value guarantees.

To confirm the validity of this Power of Attorney call 1-610-832-8240 between 9:00 am and 4:30 pm EST on any business day.

CONSTRUCTION AGREEMENT

THIS CONSTRUCTION AGREEMENT ("Agreement") is made as of August 25, 2020 and is by and between RIVERSIDE COUNTY FLOOD CONTROL AND WATER CONSERVATION DISTRICT, a body politic, (District) and SUKUT CONSTRUCTION, LLC (Contractor).

IT IS AGREED BY THE PARTIES AS FOLLOWS:

1. The Work. Contractor shall furnish all tools, equipment, apparatus, facilities, labor, supervision, services, transportation, materials and other required items and materials and do all things necessary to perform, accomplish and complete the work for **Project No. 6-0-00040-93, Palm Canyon Wash, Stage 93 Emergency Levee Restoration** of District, in exact conformity with the Contract Documents (identified below) for the Project, subject to such inspection as District deems appropriate and pursuant to orders and instructions, drawings, etc., issued by District in accordance with the Contract Documents.

2. Contract Documents. The Contract Documents for **Project No. 6-0-00040-93, Palm Canyon Wash, Stage 93 Emergency Levee Restoration** of District are:

- (a) Notice Inviting Bids to Contractors;
- (b) Instructions To Bidders;
- (c) Contractor's Proposal, including List of Subcontractors, Statement of Licensure, Non-Collusion Declaration, Iran Contracting Act Certification;
- (d) Bid Bond
- (e) Construction Agreement, including Exhibit A, Workers' Compensation Contractor Certificate, Declaration of Sufficiency of Funds, and Evidence of Insurance;
- (f) Performance Bond;
- (g) Payment Bond;
- (h) General Provisions;
- (i) Special Provisions;
- (j) Detailed Specifications;
- (k) Plans;
- (l) Appendices and any other documents included in or incorporated into the Contract Documents;
- (m) Orders, Instructions, Drawings and Plans issued by District during the course of the work in accordance with the provisions of the Contract Documents; and
- (n) Addenda No. 1.

Each of the above-mentioned documents presently in existence are by this reference incorporated herein and each of said documents not now in existence are incorporated herein as of the time of their issuance.

The Bid Bond is exonerated upon execution and delivery to District in a form satisfactory to District, of the following, duly executed by Contractor and also by its Surety as to the Bonds, Construction Agreement, Certificate of Insurance, Performance Bond, and Payment Bond.

3. Bonds - Insurance. Contractor must deliver to District and District must approve, a fully executed Performance Bond in the amount of 100% of the estimated contract price, a fully executed Payment Bond in the amount of 100% of the estimated contract price, and fully executed certificates of insurance evidencing the existence of the insurance required by Subsection 8.02 of the General Provisions. The Payment Bond and Performance Bond must be on forms furnished by District.

Should any surety on the Performance Bond or Payment Bond be deemed unsatisfactory by the Board of Supervisors of District, Contractor shall upon notice promptly substitute new Bonds in form satisfactory to District.

4. Contract Price - Payment. The District agrees to pay and the Contractor agrees to accept in full consideration for the performance of the Agreement, the sum of the total amount provided in Exhibit A, attached hereto, marked Exhibit A and by this reference made a part hereof, is provision for the Contract Price and its payment, subject to additions and deductions as provided in the Specifications and Contract Documents.

5. Contract Time for Completion. The Work shall be commenced on a date to be specified in a written "Notice To Proceed" to be issued by the District and shall be completed within the duration specified in the Specifications and Contract Documents. It is expressly agreed that except for extensions of time duly granted in the manner and for the reasons specified in the General Provisions, time shall be of the essence.

FORM APPROVED COUNTY COUNSEL
BY: Synthia M. Gunzel 8-13-2020
SYNTHIA M. GUNZEL DATE

RIVERSIDE COUNTY FLOOD CONTROL
AND WATER CONSERVATION DISTRICT

By Karen S. Spiegel
Chairwoman of its Board of Supervisors

ATTEST:

KECIA HARPER
Clerk of the Board

By Wendy Harper
Deputy

(Seal)



Sukut Construction, LLC
Contractor
By [Signature]
Felipe Oliver
Title Vice President

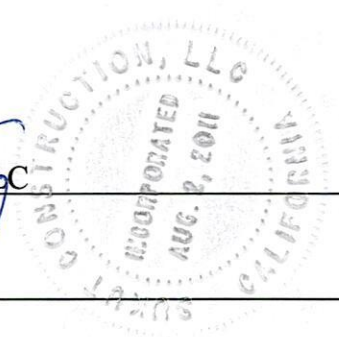

(If corporation affix corporate seal)

EXHIBIT A

(To Agreement for Riverside County Flood Control and Water Conservation District's Project No. **6-0-00040-93, Palm Canyon Wash, Stage 93 Emergency Levee Restoration**, located in the city of Palm Springs, Riverside County, California.)

Contract Price - Payment - District shall pay Contractor the following sums for the items set forth below in accordance with Contractor's Proposal as accepted by District, which sums shall be paid as provided in the General Provisions and subject to additions and deductions as provided in the Contract Documents.

It is understood that the quantities listed, except for those shown as "Final" or "Lump Sum" are but estimates only and final payment will be based on actual work performed, subject to such adjustments and alterations as elsewhere provided.

ITEM NO.	ITEM OF WORK	UNIT	QUANTITY	UNIT COST	TOTAL COST
1.	Mobilization	L.S.	---	---	\$351,783.00
2.	Water Control	L.S.	---	---	2,500.00
3.	Clearing and Miscellaneous Work	L.S.	---	---	25,000.00
4.	Excavation	C.Y.	72,000	\$2.60	187,200.00
5.	Backfill	C.Y.	61,500	\$1.95	119,925.00
6.	Embankment	C.Y.	10,500	\$2.00	21,000.00
7.	Trench Safety System	L.S.	---	---	1,500.00
8.	Class "A" Concrete, Slope Paving	C.Y.	1,750	\$450.00	787,500.00
9.	Class "B" Concrete, 2' Cutoff Wall	L.F.	1,455	\$17.00	24,735.00
10.	Class "B" Concrete, 4' Cutoff Wall	L.F.	130	\$80.00	10,400.00
11.	Remove and Reinstall Fence	L.F.	200	\$61.00	12,200.00
12.	Remove and Reinstall Gate	EACH	3	\$4,000.00	12,000.00
13.	Existing Riprap Removal, Temporary Stockpiling and Final Placement	L.S.	---	---	18,000.00
14.	Air-Blasting	L.S.	---	---	6,000.00
15.	Existing 4" Unreinforced Concrete Slope Paneling Breaking and Removal, Temporary Stockpiling and Final Placement	L.S.	---	---	28,500.00

EXHIBIT A contd.

ITEM NO.	ITEM OF WORK	UNIT	QUANTITY	UNIT COST	TOTAL COST
16.	Toe Extension Epoxy	L.F.	2,000	\$5.25	10,500.00
17.	Perimeter Demarcation Fencing	L.F.	4,000	\$3.45	13,800.00
18.	Extra Directed Work	L.S.	---	---	150,000.00
19.	Dust Abatement	L.S.	---	---	19,000.00
20.	Stormwater and Non-Stormwater Pollution Control	L.S.	---	---	58,000.00
21.	Non-Stormwater Discharge or Dewatering	L.S.	---	---	17,000.00
				TOTAL	\$1,876,543.00

PERFORMANCE BOND

(Public Work – Public Contract Code Section 21091)

WHEREAS, the Riverside County Flood Control and Water Conservation District ("District") on August 25, 2020, has awarded Construction Contract Number: 6-0-00040-93 ("Contract") to the undersigned SUKUT CONSTRUCTION, LLC, as Principal ("Principal") to perform the work ("Work") for the following project; Palm Canyon Wash, Stage 93 Emergency Levee Restoration, which Contract is by this reference hereby incorporated herein and made a part hereof;

WHEREAS, said Principal is required by the Contract and/or by California Public Contract Code, Section 21091 to furnish a performance bond for the faithful performance of the Contract;

NOW THEREFORE, we, the Principal and Liberty Mutual Insurance Company ("Surety"), an admitted surety insurer pursuant to Code of Civil Procedure, Section 995.120, are held and firmly bound unto District in the penal sum of One Million Eight Hundred Seventy Six Thousand * - Dollars (\$ 1,876,543.00), this amount being not less than one hundred percent (100%) of the total sum payable by District under the Contract at the time the Contract is awarded by District to the Principal, lawful money of the United States of America, for the payment of which sum well and truly to be made, we, Principal and Surety, bind ourselves, our heirs, executors, administrators, successors and assigns, jointly and severally, firmly by these presents, to: * Five Hundred Forty Three and no/100

1. Perform all the work required to complete the Project; and
2. Pay to the District all damages the District incurs as a result of the Contractor's failure to perform all the Work required to complete the Project.

THE CONDITION OF THIS OBLIGATION IS SUCH that if Principal, its heirs, executors, administrators, successors or assigns approved by District, shall in all things stand to and abide by and well and truly keep and perform all the undertakings, terms, covenants, conditions and agreements in the Contract, including, without limitation, all obligations during the original term and any extensions thereof as may be granted by District, with or without notice to Surety thereof (including, without limitation, the obligation for Principal to pay liquidated damages), all obligations during the period of any warranties and guarantees required under the Contract and all other obligations otherwise arising under the terms of the Contract (such as, but not limited to, obligations of indemnification), all within the time and in the manner therein designated in all respects according to their true intent and meaning, then this obligation shall become null and void; otherwise, it shall be and remain in full force and effect.

As a condition precedent to the satisfactory completion of the Contract, the above obligation shall hold good for a period equal to the warranty and/or guarantee period of the Contract, during which time Surety's obligation shall continue if Contractor shall fail to make full, complete, and satisfactory repair and replacements and totally protect the District from loss or damage resulting from or caused by defective materials or faulty workmanship. The obligations of Surety hereunder shall continue so long as any obligation of Contractor remains. Nothing herein shall limit the District's rights or the Contractor or Surety's obligations under the Contract, law or equity, including, but not limited to, California Code of Civil Procedure section 337.15.

PERFORMANCE BOND

Page 2 of 3

Whenever Principal shall be, and is declared by District to be, in default under the Contract, the Surety shall promptly either remedy the default, or, if the Contract is terminated by District or the Principal's performance of the Work is discontinued, Surety shall promptly complete the Contract through its agents or independent contractors, subject to acceptance of such agents or independent contractors by District as hereinafter set forth, in accordance with its terms and conditions and to pay and perform all obligations of Principal under the Contract (including, without limitation, all obligations with respect to payment of liquidated damages) less the "Balance of the Contract Price" (as hereinafter defined); subject to the penal amount of this bond as set forth above. The term "Balance of the Contract Price", as used in this paragraph, shall mean the total amount payable to Principal by District under the Contract and any modifications thereto, less the amount previously paid by District to the Principal and less amounts that District is authorized to withhold under the terms of the Contract.

If District determines that completion of the Contract by Surety or its agents or independent contractors must be performed by a lowest responsible bidder selected pursuant to a competitive bidding process, then Surety shall comply with such processes in accordance with the requirements of District and applicable laws. Unless otherwise approved by District, in the exercise of its sole and absolute discretion, Surety shall not utilize Principal in completing performance of the Work.

No right of action shall accrue on this bond to or for the use of any person or entity other than District or its successors or assigns.

In the event any legal proceeding or arbitration is brought upon this bond by District and judgment or award is entered in favor of District as the prevailing party, Surety shall pay all costs and attorney's fees incurred by the District.

Correspondence or claims relating to this bond shall be sent to Surety at the address set forth below.

Surety, for value received, agrees that no change, extension of time, alteration or addition to the terms of the Contract, or to the work to be performed thereunder, shall in any way impair or affect Surety's obligation under this bond, and Surety does hereby waive notice of any such changes, extensions of time, alterations or additions.

Surety's obligations hereunder are independent of the obligations of any other surety for the performance of the Contract, and suit may be brought against Surety and such other sureties, joint and severally, or against any one or more of them or against less than all of them, without impairing District's rights against the others.

PERFORMANCE BOND

Page 3 of 3

(Corporate Seal of Principal,
if Corporation)

Sukut Construction, LLC

(Proper name of Principal)

By:

Signature of Principal's authorized representative

Felipe Olivar, Vice President

Print or type authorized representative's Name and Title

4010 West Chandler Avenue, Santa Ana, CA 92704-5202

Print or type Principal's Address

(Corporate Seal of Surety)

Surety Liberty Mutual Insurance Company

By:

Attorney-in-Fact - Jeri Apodaca

(Attach Attorney-in-Fact
Certificate and Required
Acknowledgments)

Alliant Insurance Services, Inc.

Name and Address of California Agent of Surety

1301 Dove Street, Suite 200

Newport Beach, CA 92660

(949) 756-0271

Telephone Number of California Agent of Surety

NOTE: Notary acknowledgment of signatures of Principal and Surety, and Surety's Power of Attorney, must be included or attached.

CALIFORNIA ALL-PURPOSE ACKNOWLEDGMENT

CIVIL CODE § 1189

A notary public or other officer completing this certificate verifies only the identity of the individual who signed the document to which this certificate is attached, and not the truthfulness, accuracy, or validity of that document.

State of California)
County of Orange)

On 8/5/20 before me, Jami Collins, Notary Public,
Date Here Insert Name and Title of the Officer
personally appeared Felipe Oliviar
Name(s) of Signer(s)

who proved to me on the basis of satisfactory evidence to be the person(s) whose name(s) is/are subscribed to the within instrument and acknowledged to me that he/she/they executed the same in his/her/their authorized capacity(ies), and that by his/her/their signature(s) on the instrument the person(s), or the entity upon behalf of which the person(s) acted, executed the instrument.

I certify under PENALTY OF PERJURY under the laws of the State of California that the foregoing paragraph is true and correct.

WITNESS my hand and official seal.

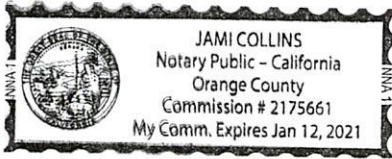

Signature Jami Collins
Signature of Notary Public

Place Notary Seal Above

OPTIONAL

Though this section is optional, completing this information can deter alteration of the document or fraudulent reattachment of this form to an unintended document.

Description of Attached Document

Title or Type of Document: _____ Document Date: _____
Number of Pages: _____ Signer(s) Other Than Named Above: _____

Capacity(ies) Claimed by Signer(s)

Signer's Name: _____
 Corporate Officer — Title(s): _____
 Partner — Limited General
 Individual Attorney in Fact
 Trustee Guardian or Conservator
 Other: _____
Signer Is Representing: _____

Signer's Name: _____
 Corporate Officer — Title(s): _____
 Partner — Limited General
 Individual Attorney in Fact
 Trustee Guardian or Conservator
 Other: _____
Signer Is Representing: _____

CALIFORNIA ALL-PURPOSE ACKNOWLEDGMENT

CIVIL CODE § 1189

A notary public or other officer completing this certificate verifies only the identity of the individual who signed the document to which this certificate is attached, and not the truthfulness, accuracy, or validity of that document.

State of California)
County of Orange)

On AUG 04 2020 before me, Heather Rose Saltarelli, Notary Public
Date Here Insert Name and Title of the Officer

personally appeared Jeri Apodaca
Name(s) of Signer(s)

who proved to me on the basis of satisfactory evidence to be the person(s) whose name(s) is/~~are~~ subscribed to the within instrument and acknowledged to me that he/~~she/they~~ executed the same in his/~~her/their~~ authorized capacity(ies), and that by his/~~her/their~~ signature(s) on the instrument the person(s), or the entity upon behalf of which the person(s) acted, executed the instrument.

I certify under PENALTY OF PERJURY under the laws of the State of California that the foregoing paragraph is true and correct.

WITNESS my hand and official seal.



Signature Heather Rose Saltarelli
Signature of Notary Public

Place Notary Seal Above

OPTIONAL

Though this section is optional, completing this information can deter alteration of the document or fraudulent reattachment of this form to an unintended document.

Description of Attached Document

Title or Type of Document: _____ Document Date: _____

Number of Pages: _____ Signer(s) Other Than Named Above: _____

Capacity(ies) Claimed by Signer(s)

Signer's Name: _____

- Corporate Officer -- Title(s): _____
- Partner -- Limited General
- Individual Attorney in Fact
- Trustee Guardian or Conservator
- Other: _____

Signer Is Representing: _____

Signer's Name: _____

- Corporate Officer -- Title(s): _____
- Partner -- Limited General
- Individual Attorney in Fact
- Trustee Guardian or Conservator
- Other: _____

Signer Is Representing: _____



This Power of Attorney limits the acts of those named herein, and they have no authority to bind the Company except in the manner and to the extent herein stated.

Liberty Mutual Insurance Company
The Ohio Casualty Insurance Company
West American Insurance Company

Certificate No: 8201964-977460

POWER OF ATTORNEY

KNOWN ALL PERSONS BY THESE PRESENTS: That The Ohio Casualty Insurance Company is a corporation duly organized under the laws of the State of New Hampshire, that Liberty Mutual Insurance Company is a corporation duly organized under the laws of the State of Massachusetts, and West American Insurance Company is a corporation duly organized under the laws of the State of Indiana (herein collectively called the "Companies"), pursuant to and by authority herein set forth, does hereby name, constitute and appoint, Rhonda C. Abel; Jeri Apodaca; Reece Joel Diaz; Maria Guise; Kim Luu; Michael D. Parizino; Rachelle Rheault; Heather Saltarelli; James A. Schaller

all of the city of Newport Beach state of California each individually if there be more than one named, its true and lawful attorney-in-fact to make, execute, seal, acknowledge and deliver, for and on its behalf as surety and as its act and deed, any and all undertakings, bonds, recognizances and other surety obligations, in pursuance of these presents and shall be as binding upon the Companies as if they have been duly signed by the president and attested by the secretary of the Companies in their own proper persons.

IN WITNESS WHEREOF, this Power of Attorney has been subscribed by an authorized officer or official of the Companies and the corporate seals of the Companies have been affixed thereto this 23rd day of August, 2019.



Liberty Mutual Insurance Company
The Ohio Casualty Insurance Company
West American Insurance Company

By: David M. Carey
David M. Carey, Assistant Secretary

Not valid for mortgage, note, loan, letter of credit, currency rate, interest rate or residual value guarantees.

To confirm the validity of this Power of Attorney call 1-610-832-8240 between 9:00 am and 4:30 pm EST on any business day.

State of PENNSYLVANIA ss
County of MONTGOMERY

On this 23rd day of August, 2019 before me personally appeared David M. Carey, who acknowledged himself to be the Assistant Secretary of Liberty Mutual Insurance Company, The Ohio Casualty Company, and West American Insurance Company, and that he, as such, being authorized so to do, execute the foregoing instrument for the purposes therein contained by signing on behalf of the corporations by himself as a duly authorized officer.

IN WITNESS WHEREOF, I have hereunto subscribed my name and affixed my notarial seal at King of Prussia, Pennsylvania, on the day and year first above written.



COMMONWEALTH OF PENNSYLVANIA
Notarial Seal
Teresa Pastella, Notary Public
Upper Merion Twp., Montgomery County
My Commission Expires March 28, 2021
Member, Pennsylvania Association of Notaries

By: Teresa Pastella
Teresa Pastella, Notary Public

This Power of Attorney is made and executed pursuant to and by authority of the following By-laws and Authorizations of The Ohio Casualty Insurance Company, Liberty Mutual Insurance Company, and West American Insurance Company which resolutions are now in full force and effect reading as follows:

ARTICLE IV - OFFICERS: Section 12. Power of Attorney.

Any officer or other official of the Corporation authorized for that purpose in writing by the Chairman or the President, and subject to such limitation as the Chairman or the President may prescribe, shall appoint such attorneys-in-fact, as may be necessary to act in behalf of the Corporation to make, execute, seal, acknowledge and deliver as surety any and all undertakings, bonds, recognizances and other surety obligations. Such attorneys-in-fact, subject to the limitations set forth in their respective powers of attorney, shall have full power to bind the Corporation by their signature and execution of any such instruments and to attach thereto the seal of the Corporation. When so executed, such instruments shall be as binding as if signed by the President and attested to by the Secretary. Any power or authority granted to any representative or attorney-in-fact under the provisions of this article may be revoked at any time by the Board, the Chairman, the President or by the officer or officers granting such power or authority.

ARTICLE XIII - Execution of Contracts: Section 5. Surety Bonds and Undertakings.

Any officer of the Company authorized for that purpose in writing by the chairman or the president, and subject to such limitations as the chairman or the president may prescribe, shall appoint such attorneys-in-fact, as may be necessary to act in behalf of the Company to make, execute, seal, acknowledge and deliver as surety any and all undertakings, bonds, recognizances and other surety obligations. Such attorneys-in-fact subject to the limitations set forth in their respective powers of attorney, shall have full power to bind the Company by their signature and execution of any such instruments and to attach thereto the seal of the Company. When so executed such instruments shall be as binding as if signed by the president and attested by the secretary.

Certificate of Designation - The President of the Company, acting pursuant to the Bylaws of the Company, authorizes David M. Carey, Assistant Secretary to appoint such attorneys-in-fact as may be necessary to act on behalf of the Company to make, execute, seal, acknowledge and deliver as surety any and all undertakings, bonds, recognizances and other surety obligations.

Authorization - By unanimous consent of the Company's Board of Directors, the Company consents that facsimile or mechanically reproduced signature of any assistant secretary of the Company, wherever appearing upon a certified copy of any power of attorney issued by the Company in connection with surety bonds, shall be valid and binding upon the Company with the same force and effect as though manually affixed.

I, Renee C. Llewellyn, the undersigned, Assistant Secretary, The Ohio Casualty Insurance Company, Liberty Mutual Insurance Company, and West American Insurance Company do hereby certify that the original power of attorney of which the foregoing is a full, true and correct copy of the Power of Attorney executed by said Companies, is in full force and effect and has not been revoked.

IN TESTIMONY WHEREOF, I have hereunto set my hand and affixed the seals of said Companies this AUG 04 2020 day of



By: Renee C. Llewellyn
Renee C. Llewellyn, Assistant Secretary

Bond No. 24246876
Premium Included in Performance Bond
Executed in Four Counterparts

PAYMENT BOND
Page 1 of 2

(Public Work - Civil Code Sections 9550 et seq.)

WHEREAS, the Riverside County Flood Control and Water Conservation District ("District") by action of the Board of Supervisors on August 25, 2020, has awarded Construction Contract Number: 6-0-00040-93 ("Contract") to the undersigned SUKUT CONSTRUCTION, LLC, as Principal ("Principal") to perform the work ("Work") for the following project; Palm Canyon Wash, Stage 93 Emergency Levee Restoration.

WHEREAS, said Principal is required by the Contract and/or by the California Civil Code Section 9550 et seq. to furnish a payment bond in connection with the Contract;

NOW THEREFORE, we, the Principal and Liberty Mutual Insurance Company ("Surety"), an admitted surety insurer pursuant to Code of Civil Procedure, Section 995.120, are held and firmly bound unto District in the penal sum of One Million Eight Hundred Seventy Six Thousand * _____ Dollars (\$ 1,876,543.00), this amount being not less than one hundred percent (100%) of the total sum payable by District under the Contract at the time the Contract is awarded by District to the Principal, lawful money of the United States of America, for the payment of which sum well and truly to be made, we, Principal and Surety, bind ourselves, our heirs, executors, administrators, successors and assigns, jointly and severally, firmly by these presents. * Five Hundred Forty Three and no/100

THE CONDITION OF THIS OBLIGATION IS SUCH that if Principal, its heirs, executors, administrators, successors, or assigns approved by District, or its subcontractors, of any contracting tier, shall fail to pay any amounts or any person or persons named and described in California Civil Code, Section 9554, then Surety will pay for the same, in or to an amount not exceeding the penal amount hereinabove set forth, and also will pay to the prevailing party if suit is brought upon this bond, reasonable attorney's fees as provided in California Civil Code, Section 9564.

Surety, for value received, agrees that no change, extension of time, alteration or addition to the terms of the Contract, or to the Work to be performed thereunder, nor any rescission or attempted rescission of the Contract or this bond, nor any conditions precedent or subsequent in the bond or Contract attempting to limit the right of recovery of any claimant otherwise entitled to recover under the Contract or this bond shall in any way impair or affect Surety's obligation under this bond, and Surety does hereby waive notice of any such changes, extensions of time, alterations or additions.

Surety is not released from liability to those for whose benefit this bond has been given, by reason of any breach of the Contract by District or Principal.

It is hereby expressly stipulated and agreed that this bond shall inure to the benefit of any and all persons, companies, and corporations entitled to file claims under Section 9100 of the Civil Code, so as to give a right of action to them or their assigns in any suit brought upon this bond.

PAYMENT BOND

Page 2 of 2

Surety's obligations hereunder are independent of the obligations of any other surety for the performance of the Contract, and suit may be brought against Surety and such other sureties, joint and severally, or against any one or more of them or against less than all of them, without impairing District's rights against the others.

Sukut Construction, LLC

(Proper name of Principal)

(Corporate Seal of Principal,
if Corporation)

By:

Signature of Principal's authorized representative

Felipe Olivar, Vice President
Print or type authorized representative's Name and Title

4010 West Chandler Avenue, Santa Ana, CA 92704-5202

Print or type Principal's Address

(Corporate Seal of Surety)

Surety Liberty Mutual Insurance Company

By:

Attorney-in-Fact - Jeri Apodaca

(Attach Attorney-in-Fact
Certificate and Required
Acknowledgments)

Alliant Insurance Services, Inc.
Name and Address of California Agent of Surety

1301 Dove Street, Suite 200

Newport Beach, CA 92660

(949) 756-0271

Telephone Number of California Agent of Surety

NOTE: Notary acknowledgment of signatures of Principal and Surety, and Surety's Power of Attorney, must be included or attached.

CALIFORNIA ALL-PURPOSE ACKNOWLEDGMENT

CIVIL CODE § 1189

A notary public or other officer completing this certificate verifies only the identity of the individual who signed the document to which this certificate is attached, and not the truthfulness, accuracy, or validity of that document.

State of California)
County of Orange)

On 8/5/20 before me, Jami Collins, Notary Public,
Date Here Insert Name and Title of the Officer
personally appeared Felipe Oliviar
Name(s) of Signer(s)

who proved to me on the basis of satisfactory evidence to be the person(s) whose name(s) is/are subscribed to the within instrument and acknowledged to me that he/she/they executed the same in his/her/their authorized capacity(ies), and that by his/her/their signature(s) on the instrument the person(s), or the entity upon behalf of which the person(s) acted, executed the instrument.

I certify under PENALTY OF PERJURY under the laws of the State of California that the foregoing paragraph is true and correct.

WITNESS my hand and official seal.



Signature Jami Collins
Signature of Notary Public

Place Notary Seal Above

OPTIONAL

Though this section is optional, completing this information can deter alteration of the document or fraudulent reattachment of this form to an unintended document.

Description of Attached Document

Title or Type of Document: _____ Document Date: _____
Number of Pages: _____ Signer(s) Other Than Named Above: _____

Capacity(ies) Claimed by Signer(s)

Signer's Name: _____
 Corporate Officer — Title(s): _____
 Partner — Limited General
 Individual Attorney in Fact
 Trustee Guardian or Conservator
 Other: _____
Signer Is Representing: _____

Signer's Name: _____
 Corporate Officer — Title(s): _____
 Partner — Limited General
 Individual Attorney in Fact
 Trustee Guardian or Conservator
 Other: _____
Signer Is Representing: _____

CALIFORNIA ALL-PURPOSE ACKNOWLEDGMENT

CIVIL CODE § 1189

A notary public or other officer completing this certificate verifies only the identity of the individual who signed the document to which this certificate is attached, and not the truthfulness, accuracy, or validity of that document.

State of California)

County of Orange)

On AUG 04 2020 before me, Heather Rose Saltarelli, Notary Public
Date Here Insert Name and Title of the Officer

personally appeared Jeri Apodaca
Name(s) of Signer(s)

who proved to me on the basis of satisfactory evidence to be the person(s) whose name(s) is/~~are~~ subscribed to the within instrument and acknowledged to me that he/~~she/they~~ executed the same in his/~~her/their~~ authorized capacity(ies), and that by his/~~her/their~~ signature(s) on the instrument the person(s), or the entity upon behalf of which the person(s) acted, executed the instrument.

I certify under PENALTY OF PERJURY under the laws of the State of California that the foregoing paragraph is true and correct.

WITNESS my hand and official seal.



Signature Heather Rose Saltarelli
Signature of Notary Public

Place Notary Seal Above

OPTIONAL

Though this section is optional, completing this information can deter alteration of the document or fraudulent reattachment of this form to an unintended document.

Description of Attached Document

Title or Type of Document: _____ Document Date: _____

Number of Pages: _____ Signer(s) Other Than Named Above: _____

Capacity(ies) Claimed by Signer(s)

Signer's Name: _____

Corporate Officer -- Title(s): _____

Partner -- Limited General

Individual Attorney in Fact

Trustee Guardian or Conservator

Other: _____

Signer Is Representing: _____

Signer's Name: _____

Corporate Officer -- Title(s): _____

Partner -- Limited General

Individual Attorney in Fact

Trustee Guardian or Conservator

Other: _____

Signer Is Representing: _____



This Power of Attorney limits the acts of those named herein, and they have no authority to bind the Company except in the manner and to the extent herein stated.

Liberty Mutual Insurance Company
The Ohio Casualty Insurance Company
West American Insurance Company

Certificate No: 8201964-977460

POWER OF ATTORNEY

KNOWN ALL PERSONS BY THESE PRESENTS: That The Ohio Casualty Insurance Company is a corporation duly organized under the laws of the State of New Hampshire, that Liberty Mutual Insurance Company is a corporation duly organized under the laws of the State of Massachusetts, and West American Insurance Company is a corporation duly organized under the laws of the State of Indiana (herein collectively called the "Companies"), pursuant to and by authority herein set forth, does hereby name, constitute and appoint, Rhonda C. Abel; Jeri Apodaca; Reece Joel Diaz; Maria Guise; Kim Luu; Michael D. Parizino; Rachelle Rheault; Heather Saltarelli; James A. Schaller

all of the city of Newport Beach state of California each individually if there be more than one named, its true and lawful attorney-in-fact to make, execute, seal, acknowledge and deliver, for and on its behalf as surety and as its act and deed, any and all undertakings, bonds, recognizances and other surety obligations, in pursuance of these presents and shall be as binding upon the Companies as if they have been duly signed by the president and attested by the secretary of the Companies in their own proper persons.

IN WITNESS WHEREOF, this Power of Attorney has been subscribed by an authorized officer or official of the Companies and the corporate seals of the Companies have been affixed thereto this 23rd day of August, 2019.



Liberty Mutual Insurance Company
The Ohio Casualty Insurance Company
West American Insurance Company

By: David M. Carey
David M. Carey, Assistant Secretary

Not valid for mortgage, note, loan, letter of credit, currency rate, interest rate or residual value guarantees.

To confirm the validity of this Power of Attorney call 1-610-832-8240 between 9:00 am and 4:30 pm EST on any business day.

State of PENNSYLVANIA ss
County of MONTGOMERY

On this 23rd day of August, 2019 before me personally appeared David M. Carey, who acknowledged himself to be the Assistant Secretary of Liberty Mutual Insurance Company, The Ohio Casualty Company, and West American Insurance Company, and that he, as such, being authorized so to do, execute the foregoing instrument for the purposes therein contained by signing on behalf of the corporations by himself as a duly authorized officer.

IN WITNESS WHEREOF, I have hereunto subscribed my name and affixed my notarial seal at King of Prussia, Pennsylvania, on the day and year first above written.



COMMONWEALTH OF PENNSYLVANIA
Notarial Seal
Teresa Pastella, Notary Public
Upper Merion Twp., Montgomery County
My Commission Expires March 28, 2021
Member, Pennsylvania Association of Notaries

By: Teresa Pastella
Teresa Pastella, Notary Public

This Power of Attorney is made and executed pursuant to and by authority of the following By-laws and Authorizations of The Ohio Casualty Insurance Company, Liberty Mutual Insurance Company, and West American Insurance Company which resolutions are now in full force and effect reading as follows:

ARTICLE IV - OFFICERS: Section 12. Power of Attorney.

Any officer or other official of the Corporation authorized for that purpose in writing by the Chairman or the President, and subject to such limitation as the Chairman or the President may prescribe, shall appoint such attorneys-in-fact, as may be necessary to act in behalf of the Corporation to make, execute, seal, acknowledge and deliver as surety any and all undertakings, bonds, recognizances and other surety obligations. Such attorneys-in-fact, subject to the limitations set forth in their respective powers of attorney, shall have full power to bind the Corporation by their signature and execution of any such instruments and to attach thereto the seal of the Corporation. When so executed, such instruments shall be as binding as if signed by the President and attested to by the Secretary. Any power or authority granted to any representative or attorney-in-fact under the provisions of this article may be revoked at any time by the Board, the Chairman, the President or by the officer or officers granting such power or authority.

ARTICLE XIII - Execution of Contracts: Section 5. Surety Bonds and Undertakings.

Any officer of the Company authorized for that purpose in writing by the chairman or the president, and subject to such limitations as the chairman or the president may prescribe, shall appoint such attorneys-in-fact, as may be necessary to act in behalf of the Company to make, execute, seal, acknowledge and deliver as surety any and all undertakings, bonds, recognizances and other surety obligations. Such attorneys-in-fact subject to the limitations set forth in their respective powers of attorney, shall have full power to bind the Company by their signature and execution of any such instruments and to attach thereto the seal of the Company. When so executed such instruments shall be as binding as if signed by the president and attested by the secretary.

Certificate of Designation - The President of the Company, acting pursuant to the Bylaws of the Company, authorizes David M. Carey, Assistant Secretary to appoint such attorneys-in-fact as may be necessary to act on behalf of the Company to make, execute, seal, acknowledge and deliver as surety any and all undertakings, bonds, recognizances and other surety obligations.

Authorization - By unanimous consent of the Company's Board of Directors, the Company consents that facsimile or mechanically reproduced signature of any assistant secretary of the Company, wherever appearing upon a certified copy of any power of attorney issued by the Company in connection with surety bonds, shall be valid and binding upon the Company with the same force and effect as though manually affixed.

I, Renee C. Llewellyn, the undersigned, Assistant Secretary, The Ohio Casualty Insurance Company, Liberty Mutual Insurance Company, and West American Insurance Company do hereby certify that the original power of attorney of which the foregoing is a full, true and correct copy of the Power of Attorney executed by said Companies, is in full force and effect and has not been revoked.

IN TESTIMONY WHEREOF, I have hereunto set my hand and affixed the seals of said Companies this AUG 04 2020 day of



By: Renee C. Llewellyn
Renee C. Llewellyn, Assistant Secretary

WORKERS' COMPENSATION CONTRACTOR CERTIFICATE

(Labor Code Sections 1860, 1861 & 3700)

In accordance with the provisions of Section 3700 of the Labor Code, every Contractor shall secure compensation in one or more of the following ways:

- (a) By being insured against liability to pay compensation by one or more insurers duly authorized to write compensation insurance in this state.
- (b) By securing from the Director of Industrial Relations a certificate of consent to self-insure either as an individual employer, or as one employer in a group of employers, which may be given upon furnishing proof satisfactory to the Director of Industrial Relations of ability to self-insure and to pay any compensation that may become due to his or her employees.
- (c) For any county, city, city and county, municipal corporation, public district, public agency, or any political subdivision of the state, including each member of a pooling arrangement under a joint exercise of powers agreement (but not the state itself), by securing from the Director of Industrial Relations a certificate of consent to self-insure against workers' compensation claims, which certificate may be given upon furnishing proof satisfactory to the director of ability to administer workers' compensation claims properly, and to pay workers' compensation claims that may become due to its employees. On or before March 31, 1979, a political subdivision of the state which, on December 31, 1978, was uninsured for its liability to pay compensation, shall file a properly completed and executed application for a certificate of consent to self-insure against workers' compensation claims. The certificate shall be issued and be subject to the provisions of Section 3702.

Labor Code Section 1861 requires each Contractor to whom a public works Contract is awarded shall sign and file with the District the following certification prior to performing the Work of the public works construction Contract:

I am aware of the provisions of Section 3700 of the Labor Code which require every employer to be insured against liability for workers' compensation or to undertake self-insurance in accordance with the provisions of that code, and I will comply with such provisions before commencing the performance of the Work of this Contract.

By signing this certification, the Contractor understands the requirements of and agrees to comply with the aforementioned requirements.

Name of Contractor: Sukut Construction, LLC

By: Felipe Olivares

Title: Vice President

DECLARATION OF SUFFICIENCY OF FUNDS

Page 1 of 3

(California Labor Code Section 2810)

I, the undersigned, an authorized representative of Sukut Construction, LLC ("Bidder") with authority to make the statements contained in this Declaration on behalf of Bidder, hereby declare the following:

1. The Bidder's employer identification number for state tax purposes is:
37-1702665

2. The Bidder's workers' compensation insurance policy number is:
WCA000018120 & WCA000017620,

and the name, address, and telephone number of the insurance carrier providing said insurance is:

ACIG Insurance Company Phone: 972.702.9004
2600 N Central Expy, Suite 800
Richardson, TX 75080

3. The following information is provided concerning any and all vehicles that are owned by the Bidder and that will be used for transportation in connection with any service provided for the performance of the Work that is the subject of the Bidder's Bid [Insert information requested. Attach additional sheets, if needed.]:

<i>Vehicle</i>	<i>Vehicle ID #</i>	<i>Vehicle Liability Insurance Policy Number (of policy covering vehicle)</i>	<i>Name, Address and Telephone Number of Vehicle Liability Insurance Carrier (issuing policy covering vehicle)</i>
SEE ATTACHED		AL20000014	American Contractors Ins. Co RRG

4. The following is the address of any real property that will be used to house workers in connection with the performance of the Work that is the subject of the Bidder's Bid [If no such housing will be provided, enter "none"]:
None

DECLARATION OF SUFFICIENCY OF FUNDS

5. The actual or estimated number of workers that will be employed to perform the Work that is the subject of the Bidder's Bid, the total amount of wages to be paid to said workers, and the dates on which said wages will be paid are as follows [Attach additional sheets, if needed.]:

<i>Total Number of Workers</i>	<i>Total Amount of Wages</i>	<i>Date(s) for Payment of Wages</i>
22	\$716,866	

6. Check only one of the following boxes, as applicable:

- The statement of number of workers declared in Paragraph 5, above, is a statement of the actual number of workers that will be employed.
- The actual number of workers requested in Paragraph 5, above, is unknown and therefore the statement of number of workers declared therein is based on the Bidder's best estimate available at the time of submitting its Bid, rather than the actual number of workers that will be employed and if and when the actual number of workers and the other information requested above is available, it will be reported to the District by Bidder in writing.

7. The actual or estimated total number of persons who will be utilized as independent Contractors to perform the Work of the Project that is the subject of the Bidder's Bid (together with their known, current local, state, and federal Contractor license identification numbers that each is required to have under local, state or federal laws or regulations) are as follows [Attach additional sheets, if needed.]:

<i>List of Independent Contractors</i>	<i>Current, local, state and federal Contractor license identification number</i>
None	

DECLARATION OF SUFFICIENCY OF FUNDS

Page 3 of 3

8. Check only one of the following boxes, as applicable:

- The statement of number of independent Contractors declared in Paragraph 7, above, is a statement of the actual number of independent Contractors that will be utilized.
- The actual number of independent Contractors requested in Paragraph 7, above, is unknown and therefore the statement of number of independent Contractors declared therein is based on the Bidder's best estimate available at the time of submitting its Bid, rather than the actual number of independent Contractors that will be utilized, and if and when the actual number of independent Contractors and the other information requested above is available, it will be reported to the District by Bidder in writing.

I, the undersigned, declare under penalty of perjury that the foregoing statements are within my personal knowledge and are true and correct. Executed on this 5th day of August, in the year 2020 at Santa Ana, California.

(Signature)

Felipe Olivar, Vice President

Type Name of Signer:

Sukut Construction, LLC

Type Name of Bidder:

YEAR	MAKE/MODEL	TYPE	VIN	PLATE #
2004	Chevy 2500	4x4 Crew Cab	1GBHC23U94F241471	7T82148
2000	Sterling	McClellan 4000g Fuel Body - TRUCRS 2020	2FZNAJBB6YAF19471	10628E1
1997	Ford L7500	Sterling Lube Body - TRUCRS 2020	1FTXN80E8VVA36944	7Y36506
2009	Chevy 1500	Hybrid 4x4 Crew Cab	2GCFK135791117724	8T76040
2009	Chevy 3500HD	4x2 Ext Cab Combo Body	1GBJC79K99E112342	8Z64683
2010	Chevy 1500	Hybrid 4x4	3GCUKUEJ6BG134675	29304B1
2009	Ford F750	Mechanics Body - TRUCRS 2023	3FRWF75DX9V143803	58197F1
2008	International 4300	8.8k Brutus Bed - TRUCRS 2023	1HTMMAAP08H651278	96164F1
2011	Chevy 1500	4x4 Hybrid Crew Cab	3GCUKUEJ3BG207324	91802C1
2010	Ford F750	20' Lincoln Lube Body - TRUCRS 2023	3FRXF7FE7AV271223	85124W1
2004	Ford F550	XL Triton V10 - Lube Body	1FDAF56S14EC42535	60074T1
2011	Chevy 2500HD	4x4	1GC0KVCG3BZ337759	72357F2
2011	Chevy 1500	LT 4x4	3GCPKSEA8BG209006	29894E1
2011	Ford F750	Mechanics Body	3FRWF7FC7BV619274	10413E1
2004	Ford F650	Mechanics Body - TRUCRS 2021	3FRNF65S34V689453	04209D1
2005	Chevy C4500	Mechanics Body 11' 4x4 - TRUCRS 2021	1GBE4C3205F519812	58196F1
2006	Ford F150	XL 2wd	1FTRF12WX6KD82662	01204E1
2011	International 4400	McClellan Fuel & Lube Body - SBA 1999	1HTMKAAN4BH341369	74896D1
2003	GMC C7500	Mechanics Body	1GDJ7E1E23F522519	7L48272
2002	Ford F650	XL, Mechanics Body - TRUCRS 2020	3FDWF65A52MA28708	6Y08658
2011	Chevy 3500HD	4x2 Combo Body	1GB4CZCGXBF205125	27800G1
2012	Chevy 2500HD	4x4 Reg Cab	1GC0KVCG3CZ214609	77056G1
2012	Chevy 2500HD	4x4 Reg Cab	1GC0KVCG2CZ134668	77059G1
2006	Chevy 3500HD	4x2 Flatbed	1GBJC34U86E217581	95092G1
2012	Ford F550	Mechanics Body	1FDUF5GTXCBE89605	47193H1
2011	Ford F650	Fuel Truck	3FRNF6FB3BV619270	78600J2
2012	Ford F550	Mechanics Body	1FDUF5GT0CEC01333	46971H1
2007	Dodge 2500	Pickup	3D7KR29A77G794805	8P06309
2013	Chevy 1500	Hybrid 4x4	3GCUKUEJ7DG163556	01549K1
2013	International 4400	Fuel & Lube Body - SBA	1HTMKAAN4DH419734	51867E1
2013	Caterpillar CT660	Fuel & Lube Body	1HTJGKT1DJ400385	48380E1
2012	Ford F550	Mechanics Body	1FDUF5GT3CEB78937	80503H1
2012	Chevy 3500HD	4x2 Extra Cab	1GB5CZCG7CZ287920	54193L1
2013	Ford F550	Mechanics Body	1FDUF5GT8DEB14684	82260H1
2012	Freightliner M2	Mechanics Body	1FVACXDT6DHF60298	10525N1
2013	Chevy 1500	4x4	1GCNKPEA5DZ287508	75796L1
2013	Chevy 1500	4x4	1GCNKPEA2DZ111032	75795L1
2014	Chevy 1500	4x4 Club Cab	3GCUKREXEG109118	69054M1
2012	Ford F650	Fuel Body, V10	3FRNF6HP4CV321966	07519M1
2010	Ford F250	XL 4x4 Crew Cab Combo Body	1FTSW2BY0AEB18799	97689Z1
2010	Ford F250	XL 4x4 Crew Cab Combo Body	1FTSW2BY7AEB18766	09240N1
2010	Ford F250	XL 4x4 Crew Cab Combo Body	1FTSW2BY3AEB18800	80160N1
2013	Chevy 1500	4x4 Extra Cab	1GCRKSE72DZ348628	68054M1
2013	Chevy 1500	4x4 Extra Cab	1GCRKSE7XDZ357352	68056M1
2013	Chevy 3500HD	Combo Body Club Cab	1GB4CZCG3DF181091	68067M1
2013	Ford F550	Mechanics Body	1FDUF5GT9DEB30747	10527N1

2013	Ford F550	Mechanics Body	1FDUF5GT2DEB30749	10526N1
2013	Chevy 1500	Extra Cab	1GCRKSE73DZ406861	68099M1
2013	Ford F650	Triton V10 Mechanics Body	3FRNF6HD0DV762548	97749M1
2012	Ford F650	2000g Fuel Body	3FRNF6HPXCV192356	95829F1
2014	Chevy 3500HD	Crew Cab Combo Body	1GB4CZCG9EF137369	69093M1
2013	Ford F650	Mechanics Body	3FRNF6HD3DV789601	88322N1
2014	Chevy 1500	4x2 Crew Cab	3GCPCPEH1EG263243	94240N1
2013	Ford F650	2000g Fuel Body	3FRNF6HD3DV780087	28426M1
2014	Chevy 1500	Crew Cab	3GCUKPEH8EG349140	25500P1
2014	Chevy 1500	Crew Cab	3GCUKPEH9EG349163	25501P1
2014	Chevy 1500	Crew Cab	3GCUKPEH1EG372050	25523P1
2014	Chevy 1500	Crew Cab	3GCUKPEH5EG372049	25524P1
2014	Ford F550	Triton V10 Mechanics Body	1FDUF5GY2EEA35038	34545P1
2014	Chevy 3500HD	Crew Cab	1GB4CZCG6EF115202	98956P1
2014	Chevy 3500HD	4x2 Combo Body	1GB3CZCGXEF151437	98965P1
2014	Ford F550	4x2 Triton V10 Mechanics Body	1FDUF5GY4EEA35039	35454P1
2012	Ford F350	XL 4x4 Extra Cab	1FT7X3B61CEB42667	92163S1
2014	Chevy 3500HD	Combo Body	1GB4CZCG8EF116559	03251S1
2014	Chevy 1500	4x4 Crew Cab	3GCUKPEHXEG403845	03252S1
2015	Ford F550	4x4 Mechanics Body	1FDUF5HT5FEA09165	92164S1
2015	Ford F650	Triton V10 Denardi Lube Bed	3FRNF6HP9FV567786	63069S1
2015	Ford F650	Triton V10 Lube Bed	3FRNF6HP6FV567759	90623K2
2014	Chevy 1500	4x4 Crew Cab	3GCUKPEH5EG415711	68339S1
2014	Chevy 3500HD	Combo Body	1GB4CZCG7EF127455	78029S1
2013	Ford F550	Mechanics Body	1FDUF5GTODEB37375	07393T1
2013	Ford F150	XL 4x4	1FTMF1EMODKF00090	09085U1
2013	Ford F150	XL 4x4	1FTMF1EM4DKF00092	89280K2
2013	Ford F150	XL 4x4	1FTMF1EM1DKF00096	09083U1
2015	Ford F650	Triton V10 Denardi Lube Bed	3FRNF6HP3FV704883	75472T1
2015	Chevy 1500	4x4 Crew Cab	3GCUKPEH6EG525618	95264T1
2015	Chevy 3500HD	Combo Body	1GB4CYCG3FF152154	96660T1
2015	Chevy 1500	Z71 4x4 Crew Cab	3GCUKREC7FG287294	51891V1
2015	Chevy 1500	Z71 4x4 Crew Cab	3GCUKREC9FG169134	51893V1
2012	Ford F150	XL 4x4 Crew Cab	1FTFW1EF4CKD69531	25754V1
2014	Ford F150	XL 4x4 Crew Cab	1FTFW1ET1EKE39110	25753V1
2014	Chevy 1500	4x4 Single Cab	1GCNKPEH7EZ272751	52825V1
2014	Chevy 1500	4x4 Single Cab	1GCNKPEH9EZ270094	52824V1
2011	Chevy 3500HD	Flatbed	1GB3CZCG4BF262741	02387F1
2015	Ford F550	Triton V10 Mechanics Body	1FDUF5GY2FED32800	03065W1
2015	Ford F650	Triton V10 Lube Bed	3FRNF6HP2FV730617	57887V1
2015	Peterbilt 337	Mechanics Body	2NP2HJ7X4FM282416	35656W1
2015	Chevy 3500HD	Combo Body	1GB4CYCG8FF602090	07373W1
2015	Chevy 1500	4x4 Crew Cab	3GCUKPEH5FG343054	61004W1
2015	Chevy 3500HD	4x4 Club Cab Combo Body	1GB4CYCG9FF601949	61003W1
2013	Chevy 1500	4x4 Single Cab Long Bed	1GCNKPE03DZ364562	84323W1
2015	Ford F650	Parts Truck - Flatbed 24'	3FRWF6FC8FV686286	59390V1
2015	Peterbilt 337	Mechanics Body	2NP2HJ7X2FM282415	35657W1

2015	Chevy 1500	1500 4x4 Crew Cab	3GCUKPEH9FG341775	61640W1
2015	Ford F550	Triton V10 Mechanics Body	1FDUF5GYXFE895847	36941S1
2010	Ford F150	XL 4x4 Extra Cab	1FTFX1EVOAFB125554	91871W1
2015	Chevy 3500HD	Crew Cab Combo Body	1GB4CYCG3FF616463	62334W1
2015	Chevy 1500	4x4 Crew Cab	3GCUKPEH5FG381951	62331W1
2015	Chevy 1500	4x4 Crew Cab	3GCUKPEH9FG345373	62332W1
2015	Ford F150	XLT 4x4 Crew Cab	1FTFW1EF4EFA45846	85115W1
2015	Chevy 1500	4x4 Crew Cab	3GCUKPEH0FG398298	14454X1
2015	Chevy 3500HD	Crew Cab Combo Body	1GB4CYCG1FF633987	90348X1
2012	Ford F550	Mechanics Body	1FDUF5GT0CEB24706	60371X1
2015	Chevy 1500	4x4 Crew Cab	3GCUKPEH1FG399542	90349X1
2015	Chevy 2500HD	4x4 Crew Cab	1GC1KVEG9FF578797	06105Y1
2015	Chevy 1500	4x4 Crew Cab	3GCUKPEH6FG446645	90972X1
2015	Chevy 1500	4x4 Crew Cab	3GCUKPEH1FG399833	90971X1
2012	Caterpillar CT660S	2000 Gallon Lube Truck (TRK00282)	1HTJGKTSJ650677	05048Z1
2011	Chevy 3500HD	4x4 Flatbed	1GB4KZCG8BF234741	05865Y1
2015	Chevy 1500	Crew Cab	3GCUKPEH7FG399870	91589X1
2015	Chevy 1500	Crew Cab	3GCUKPEH0FG407632	91591X1
2008	Ford F550	4x4 Mechanics Body	1FDAF57Y98ED93485	60913X1
2013	Peterbilt 337	Mechanics Body	2NP2HN7X4DM202651	03411Y1
2015	Chevy 1500	LTZ 4x4 Crew Cab	1GCUKSEC3FF205067	91580X1
2011	Ford F250	4x4 Crew Cab	1FTW2B61BEC21445	05971Y1
2011	Chevy 2500HD	4x4 Ext Cab	1GC2KVCG4BZ278651	05867Y1
2011	Chevy 2500HD	4x4 Ext Cab	1GC2KVCGBZ380584	05866Y1
2011	Ford F150	4x4 Reg Cab	1FTNF1EF3BKE04246	05969Y1
2011	Ford F150	4x4 Reg Cab	1FTNF1EF5BKE04247	05970Y1
2015	Chevy 1500	4x4 Crew Cab	3GCUKPEH1FG428716	92461X1
2014	International 4400	Parts Truck - Flatbed	3HAMSZR3EL019148	16230W1
2012	Peterbilt	3000 Gallon Fuel Truck	2NP2HN8X0CM160587	15893A2
2015	Chevy 3500HD	4x4 Utility Bed	1GC5KZCG9FZ127329	33859B2
2016	Chevy 1500	4x4 Crew Cab	3GCUKNEH5GG103203	69525Y1
2011	Peterbilt 337	S/A Fuel and Lube Body	2NP2HN7X0BM123121	05049Z1
2014	Chevy 3500HD	4x4 Crew Cab Utility Truck	1GB4KZCG4EF101768	05038Z1
2014	Chevy 3500HD	4x4 Crew Cab Utility Truck	1GB4KYCG4FF190494	05039Z1
2016	Chevy 1500	4x4 Crew Cab	3GCUKNEH1GG116322	81601Z1
2016	Chevy 1500	4x4 Crew Cab	3GCUKNEH8GG116334	81602Z1
2016	Peterbilt 337	Mechanics Body	2NP2HJ7X6GM357778	65075T1
2011	Ford F350	4x4 Crew Cab	1FT8W3B67BEB97467	93069A2
2016	Chevy 1500	4x4 Crew Cab	3GCUKNEH9GG116343	83249Z1
2016	Chevy 1500	4x4 Crew Cab	3GCUKNEH2GG135672	83248Z1
2016	Chevy 1500	4x4 Crew Cab	3GCUKNEH8GG144005	59717J1
2016	Chevy 1500	4x4 Crew Cab	3GCUKNEH2GG158790	86944M1
2016	Chevy 1500	4x4 Crew Cab	3GCUKREC7GG246360	83749Z1
2015	Chevy 3500HD	Crew Cab Combo Body	1GB4CYCGXGF129049	42017A2
2014	Ford F250	XL Crew Cab	1FT7W2B66EEA22198	97433Z1
2016	Chevy 1500	4x4 Crew Cab	3GCUKNEH6GG144844	58489M1
2016	Chevy 1500	4x4 Crew Cab	3GCUKNEH4GG143644	26262J1

2016	Chevy 3500HD	Utility Truck	1GB4CYCG0GF101812	58491M1
2011	Peterbilt 337	Mechanics Body	2NP2HM6X7BM130188	15392V1
2012	Peterbilt 337	Mechanics Body	2NP2HM6X7CM142696	70017C2
2015	GMC 1500	SLT 4x4 Crew Cab	3GTU2VEC3FG454372	48078X1
2014	Chevy 2500HD	4x4	1GC0KVC9EF139497	66617C2
2016	Chevy 3500HD	Combo Body	1GB4CYCG6GF167975	59361L1
2016	Ford F750	Lube Body	1FDPF7AY9GDA01298	97132D2
2012	Ford F750	2000 Gallon Water Truck	3FRNF7FAXCV442327	73062F2
2016	Chevy 1500	4x4 Crew Cab	3GCUKNECXGG329404	72385D2
2016	Chevy 1500	4x4 Crew Cab	3GCUKNEC0GG330450	72384D2
2016	Chevy 1500	4x4 Reg Cab	1GCNKNEC6GZ409917	73505D2
2016	Chevy 1500	4x4 Reg Cab	1GCNKNEC3GZ419935	73504D2
2016	Ford F550	4x2 Lube Truck	1FDUF5GY9GEB61206	51619B2
2016	Chevy 3500HD	Combo Body	1GB4CYCG8GF182767	64276E2
2017	Ford F650	4x2 Grout Truck	1FDNF6AY3HDB00802	33788D2
2017	Chevy 3500HD	Club Cab Combo Body	1GB4CYCG3GF251428	67504E2
2017	Chevy 1500	4x4 Crew Cab	3GCUKNEC2HG232277	67082E2
2017	Peterbilt 348	Parts Truck - Flatbed	2NP3LJ0X4HM415868	57617E2
2017	Chevy 1500	4x4 Crew Cab	3GCUKNEC6HG362515	58251M1
2017	Chevy 1500	4x4 Crew Cab	3GCUKNEC0HG365488	46752G2
2014	Ford F550	Mechanics Body	1FDUF5GT6DEB80893	23199S1
2013	Ford F450	Contractor Body Welders Truck	1FDUF4GTDXDEB77246	8K38886
2016	Ford F750	Lube Truck	1FDPF7DC2GDA01868	93319G2
2017	Ford F650	Parts Truck - Flatbed 24'	1FDWF6DC5HDB00790	82483B2
2017	Chevy 1500	4x4 Crew Cab	3GCUKNEH3HG248256	75207G2
2017	Chevy 1500	4x4 Crew Cab	3GCUKNEHXHG362139	75208G2
2017	Chevy 1500	4x4 Crew Cab	3GCUKNEC3HG438773	75797G2
2016	Dodge 3500	Flatbed	3C7WRSAL7GG280562	09331H2
2015	Chevy 1500	LTZ 4x4 Crew Cab	3GCUKSEC8FG109949	42878J2
2015	Ford F750	2000 Gallon Fuel Truck	3FRPF7FC9FV708581	65464H2
2015	Ford F750	Lube Truck	3FRPF7FC4FV708584	65465H2
2015	Ford F750	Mechanics Body	3FRPF7FC8FV708586	65463H2
2018	Peterbilt 337	Mechanics Body	2NP2HJ7XOJM463702	30118H2
2017	Chevy 3500	Combo Body	1GB4CYCG2HF167442	38609H2
2011	Ford F750	Mechanics Body	3FRWF7FJ5BV377776	43989J2
2017	Chevy 1500	Crew Cab	3GCUKNEC3HG464189	22766A2
2017	Chevy 1500	4x4 Crew Cab	3GCUKNEC8HG458775	98767H2
2017	Chevy 3500HD	Club Cab Combo Body	1GB4CYCG3HF217507	13920K2
2017	Chevy 3500HD	Club Cab Combo Body	1GB4CYCG8HF204610	28662K2
2017	Chevy 3500HD	4x2 Combo Body	1GB3CYCG4HF197828	96504H2
2017	Chevy 3500HD	Combo Body	1GB3CYCG1HF200118	96505H2
2017	Chevy 1500	4x4 Crew Cab	3GCUKNEC1HG460061	34805K2
2017	Chevy 1500	4x4 Crew Cab	3GCUKNEC3HG460515	34807K2
2018	Chevy 3500HD	Crew Cab Combo Body	1GB4CYCG8JF109180	99899T2
2018	Chevy 1500	4x4 Crew Cab	3GCUKSEC1JG263671	65705L2
2018	Chevy 1500	4x4 Crew Cab	3GCUKSEC6JG304988	65706L2
2018	Chevy 1500	4x4 Crew Cab	3GCUKNEC7HG463773	59310M2

2018	Chevy 1500	4x4 Crew Cab	3GCUKNEC3HG509244	65602M2
2017	Chevy 1500	4x4 Crew Cab	3GCUKNEC6JG129160	96039M2
2011	Ford F750	Mechanics Body	3FRWF7FKXBV550538	11781N2
2018	Chevy 1500	4x4 Crew Cab	3GCUKNEH9JG153867	97751M2
2019	Chevy 1500	LTZ 4x4 Crew Cab	1GCUYGEL7KZ116333	38181P2
2019	Chevy 3500HD	Crew Cab Combo Body	1GB4CYCG3JF274750	84889F2
2018	Ford F650	4x4 Mechanics Body	1FDUF5HTXHED79188	91798J2
2019	Chevy 1500	4x4 Crew Cab	1GCUYAEF2KZ197250	61108R2
2019	Chevy 1500	4x4 Crew Cab	1GCUYAEF5KZ198585	61109R2
2019	Chevy 1500	4x4 Crew Cab	1GCUYAEF7KZ200337	61103R2
2019	Chevy 1500	4x4 Crew Cab	1GCUYAEF4KZ200892	61106R2
2019	Chevy 1500	4x4 Crew Cab	1GCUYAEF7KZ201633	61102R2
2019	Chevy 2500	LTZ Z71 4x4 Crew Cab	1GC1KTEG9KF102273	45921S2
2019	Chevy 2500	4x4 Crew Cab	1GC1KREG1KF194336	26917T2
2019	Chevy 1500	4x4 Crew Cab	3GCUKNEC2JG532908	26916T2
2019	Ford F550	Combo Body	1FDUF5GYXKDA11748	55235S2
2019	Ford F550	GPS Body	1FDUF5GY4KDA11745	55224S2
2019	Chevy 1500	4x4 Crew Cab	1GCUYAEF0KZ291028	56143T2
2019	Chevy 1500	4x4 Crew Cab	1GCUYAEF5KZ289341	56142T2
2019	Chevy 1500	4x4 Crew Cab	1GCUYAEF2KZ289412	29091U2
2019	Chevy 1500	4x4 Crew Cab	1GCUYAEF1KZ289353	29093U2
2019	Chevy 1500	4x4 Crew Cab	1GCUYAEF0KZ290588	29099U2
2013	Dodge 5500	4x4 Mechanics Body	3C7WRNBL5DG594951	66722V2
2013	Ford F550	XL Knapheide Lube	1FDUF5GT4CEB75318	66212V2
2019	Chevy MD6500	Mechanics Body	1HTKHPVM8KH811879	77942U2
2019	Chevy 1500	4x4 Club Cab	1GCUYAEFKZ317277	17296V2
2019	Chevy 1500	4x4 Club Cab	1GCUYAEF6KZ318006	17293V2
2017	Dodge 1500	Rebel 4x4 Crew Cab	1C6RR7YT0HS738523	27289J2
2019	Chevy 1500	4x4 Crew Cab	1GCUYAEF2KZ317351	28876V2
2019	Chevy 1500	4x4 Crew Cab	1GCUYAEF2KZ317239	29121V2
2019	Chevy 1500	4x4 Crew Cab	1GCUYAEF2KZ317842	28867V2
2019	Chevy 3500HD	Crew Cab Combo Body	1GB4CYCG1KF210545	03316V2
2019	Chevy 1500	4x4 Crew Cab	1GCPYAEH2KZ371588	41071W2
2019	Chevy 1500	4x4 Crew Cab	1GCPYAEH4KZ370877	41070W2
2016	Ford F150	4x4 Crew Cab	1FTEW1EG9GKE16742	33764D2
2012	Ford F550	XL Mechanics Body	1FDUF5GT3CEC34486	24747A3
2020	Chevy 1500	High Country 4x4 Crew Cab	1GCUYHEL0LZ130145	58648W2



SUKUT CONS

RFINLAYSON

CERTIFICATE OF LIABILITY INSURANCE

DATE (MM/DD/YYYY)
8/4/2020

THIS CERTIFICATE IS ISSUED AS A MATTER OF INFORMATION ONLY AND CONFERS NO RIGHTS UPON THE CERTIFICATE HOLDER. THIS CERTIFICATE DOES NOT AFFIRMATIVELY OR NEGATIVELY AMEND, EXTEND OR ALTER THE COVERAGE AFFORDED BY THE POLICIES BELOW. THIS CERTIFICATE OF INSURANCE DOES NOT CONSTITUTE A CONTRACT BETWEEN THE ISSUING INSURER(S), AUTHORIZED REPRESENTATIVE OR PRODUCER, AND THE CERTIFICATE HOLDER.

IMPORTANT: If the certificate holder is an ADDITIONAL INSURED, the policy(ies) must have ADDITIONAL INSURED provisions or be endorsed. If SUBROGATION IS WAIVED, subject to the terms and conditions of the policy, certain policies may require an endorsement. A statement on this certificate does not confer rights to the certificate holder in lieu of such endorsement(s).

PRODUCER The Wooditch Company Insurance Services, Inc. 1 Park Plaza, Suite 400 Irvine, CA 92614	CONTACT NAME: PHONE (A/C, No, Ext): (949) 553-9800	FAX (A/C, No): (949) 553-0670
	E-MAIL ADDRESS:	
INSURER(S) AFFORDING COVERAGE		NAIC #
INSURER A : American Contractors Ins. Co RRG		12300 A V111
INSURER B : ACIG Insurance Company		19984 A V111
INSURER C :		
INSURER D :		
INSURER E :		
INSURER F :		

INSURED Sukut Construction, LLC 4010 W. Chandler Avenue Santa Ana, CA 92704	INSURER A : American Contractors Ins. Co RRG	12300 A V111
	INSURER B : ACIG Insurance Company	19984 A V111
	INSURER C :	
	INSURER D :	
	INSURER E :	
	INSURER F :	

COVERAGES CERTIFICATE NUMBER: REVISION NUMBER:

THIS IS TO CERTIFY THAT THE POLICIES OF INSURANCE LISTED BELOW HAVE BEEN ISSUED TO THE INSURED NAMED ABOVE FOR THE POLICY PERIOD INDICATED. NOTWITHSTANDING ANY REQUIREMENT, TERM OR CONDITION OF ANY CONTRACT OR OTHER DOCUMENT WITH RESPECT TO WHICH THIS CERTIFICATE MAY BE ISSUED OR MAY PERTAIN, THE INSURANCE AFFORDED BY THE POLICIES DESCRIBED HEREIN IS SUBJECT TO ALL THE TERMS, EXCLUSIONS AND CONDITIONS OF SUCH POLICIES. LIMITS SHOWN MAY HAVE BEEN REDUCED BY PAID CLAIMS.

INSR LTR	TYPE OF INSURANCE	ADDL INSD	SUBR WVD	POLICY NUMBER	POLICY EFF (MM/DD/YYYY)	POLICY EXP (MM/DD/YYYY)	LIMITS
A	<input checked="" type="checkbox"/> COMMERCIAL GENERAL LIABILITY CLAIMS-MADE <input checked="" type="checkbox"/> OCCUR GEN'L AGGREGATE LIMIT APPLIES PER: <input type="checkbox"/> POLICY <input checked="" type="checkbox"/> PROJECT <input type="checkbox"/> LOC OTHER:	X	X	GL20A00047 - SEE NOTES	6/1/2020	6/1/2021	EACH OCCURRENCE \$ 5,000,000 DAMAGE TO RENTED PREMISES (Ea occurrence) \$ 100,000 MED EXP (Any one person) \$ 5,000 PERSONAL & ADV INJURY \$ 5,000,000 GENERAL AGGREGATE \$ 5,000,000 PRODUCTS - COMP/OP AGG \$ 5,000,000 \$
A	<input checked="" type="checkbox"/> AUTOMOBILE LIABILITY <input checked="" type="checkbox"/> ANY AUTO OWNED AUTOS ONLY <input type="checkbox"/> SCHEDULED AUTOS <input checked="" type="checkbox"/> HIRED AUTOS ONLY <input checked="" type="checkbox"/> NON-OWNED AUTOS ONLY			AL20000014	6/1/2020	6/1/2021	COMBINED SINGLE LIMIT (Ea accident) \$ 5,000,000 BODILY INJURY (Per person) \$ BODILY INJURY (Per accident) \$ PROPERTY DAMAGE (Per accident) \$ \$
	<input type="checkbox"/> UMBRELLA LIAB <input type="checkbox"/> EXCESS LIAB DED RETENTION \$						<input type="checkbox"/> OCCUR CLAIMS-MADE EACH OCCURRENCE \$ AGGREGATE \$ \$
B	<input type="checkbox"/> WORKERS COMPENSATION AND EMPLOYERS' LIABILITY ANY PROPRIETOR/PARTNER/EXECUTIVE OFFICER/MEMBER EXCLUDED? (Mandatory in NH) <input type="checkbox"/> Y/N If yes, describe under DESCRIPTION OF OPERATIONS below		N/A	WCA000018120 - SEE NOTES	6/1/2020	6/1/2021	<input checked="" type="checkbox"/> PER STATUTE <input type="checkbox"/> OTH-ER E.L. EACH ACCIDENT \$ 1,000,000 E.L. DISEASE - EA EMPLOYEE \$ 1,000,000 E.L. DISEASE - POLICY LIMIT \$ 1,000,000

DESCRIPTION OF OPERATIONS / LOCATIONS / VEHICLES (ACORD 101, Additional Remarks Schedule, may be attached if more space is required)
 RE: Riverside County Project No. 6-0-00040-93; Palm Canyon Wash, Stage 93, Emergency Levee Restoration. glaiwv
 Riverside County Flood Control and Water Conservation District, the County of Riverside, and the City of Palm Springs are included as Additional Insureds as respects General Liability per attached endorsement.
 Waiver of Subrogation for General Liability: See Attached Endorsement.

CERTIFICATE HOLDER Riverside County Flood Control and Water Conservation District 1995 Market Street Riverside, CA 92501	CANCELLATION SHOULD ANY OF THE ABOVE DESCRIBED POLICIES BE CANCELLED BEFORE THE EXPIRATION DATE THEREOF, NOTICE WILL BE DELIVERED IN ACCORDANCE WITH THE POLICY PROVISIONS. AUTHORIZED REPRESENTATIVE 
--	--



ADDITIONAL REMARKS SCHEDULE

AGENCY		NAMED INSURED Sukut Construction, LLC 4010 W. Chandler Avenue Santa Ana, CA 92704
POLICY NUMBER SEE PAGE 1		
CARRIER SEE PAGE 1	NAIC CODE SEE P 1	EFFECTIVE DATE: SEE PAGE 1

ADDITIONAL REMARKS

THIS ADDITIONAL REMARKS FORM IS A SCHEDULE TO ACORD FORM,
FORM NUMBER: ACORD 25 FORM TITLE: Certificate of Liability Insurance

Cancellation:

*Except 10 Days Notice of Cancellation for Non-Payment of Premium.

Should this policy be cancelled before the expiration date, The Wooditch Company will mail 30 (thirty) days written notice to those Certificate Holders which require such action per contract or agreement.

General Liability:

Continued Policy Numbers: GL20B00047, GL20C00047

Workers' Compensation:

Continued Policy Numbers: WCA000018120, WCA000017620

ADDITIONAL INSURED – AUTOMATIC STATUS AS REQUIRED BY CONTRACT – BLANKET

This endorsement modifies insurance provided under the following:

COMMERCIAL GENERAL LIABILITY COVERAGE PART

SCHEDULE

Any person or organization that you are required by written contract to include as an additional insured on this policy if the contract is executed prior to the loss.

- A. Who is an Insured (Section II) is amended to include as an insured any person or organization shown in the above SCHEDULE (called additional insured), but only with respect to liability for "bodily injury", "property damage" or "personal and advertising injury" arising out of your premises or your operations for the additional insured, and only to the extent and for the minimum limits required in the written contract.
- B. The insurance provided to the additional insured is subject to the following limitations:
1. Unless required by written contract, this insurance does not apply to "bodily injury" or "property damage" occurring after "your work" for the additional insured has been completed or after that portion of "your work" out of which the "bodily injury" or "property damage" arises has been put to its intended use by any person or organization, whichever occurs first.
 2. Unless specifically required by written contract, this insurance does not apply to "bodily injury" or "property damage" arising out of the sole negligence, act or omission of the additional insured.
 3. This insurance does not apply to "bodily injury", "property damage" or "personal and advertising injury" for which the additional insured is obligated to pay damages by reason of the assumption of liability in a contract or agreement except to the extent that the additional insured would have been obligated to pay such damages in the absence of the contract or agreement.
 4. This insurance does not apply to "bodily injury", "property damage" or "personal and advertising injury" arising out of the rendering or failure to render any professional services by any insured or on any insured's behalf, including:
 - a) The preparing, approving or failing to prepare or approve maps, shop drawings, opinions, reports, surveys, field orders, change orders, drawings or specifications; and
 - b) Supervisory, inspection, architectural or engineering services.

This exclusion applies even if the claims against any insured allege negligence or other wrongdoing in the supervision, hiring, employment, training or monitoring of others by that insured, if the "occurrence" which caused the "bodily injury" or "property damage", or the offense which caused the "personal and advertising injury", involved the rendering of, or the failure to render, any professional architectural, engineering or surveying services.
 5. This endorsement shall not apply to a person or organization if any other additional insured endorsement attached to this policy specifically applies to that person or organization.
 6. The insurance afforded herein only applies to the extent permitted by applicable state law, including statutes governing additional insured coverage in the construction industry.
 7. The insurance afforded to the additional insured shall not exceed the minimum limits required in the written contract.
- C. In no event shall the insurance provided to the additional insured exceed the scope of coverage, including minimum limits, required by the contract. If a written contract or agreement requires that additional insured status be provided by the use of specified edition dates of the ISO CG2010 and/or CG2037, then the terms of that endorsement are incorporated into this endorsement as respects such additional insured and shall supersede the coverage grant and limitations in Sections A. and B. of this endorsement. In the event that CG2010 and/or CG2037 are required but no edition dates are specified, the 04/13 editions shall apply.
- D. This insurance is excess to any other insurance, whether primary, excess, contingent or on any other basis, available to the additional insured unless a written contract requires that this insurance be primary or primary and non-contributing. However, this insurance is always excess to other insurance, whether primary, excess, contingent or on any other basis, when the additional insured has been added to the other insurance as an additional insured.

Nothing herein contained shall be held to vary, alter, waive or extend any of the terms, conditions, provisions, agreements or limitations of the mentioned Policy, other than as above stated.

This endorsement changes the policy to which it is attached and is effective on the date issued unless otherwise stated.
(The information below is required only when this endorsement is issued subsequent to preparation of the policy.)

Endorsement Effective: **Same as policy effective date unless otherwise indicated above.**

Policy Effective: 6/1/2020

Policy No.: GL20A00047

Endorsement No.:

Insured: Sukut Construction, LLC

Premium \$

Insurance Company: American Contractors Insurance Co. RRG

WAIVER OF TRANSFER OF RIGHTS OF RECOVERY

This endorsement modifies insurance provided under the following:

COMMERCIAL GENERAL LIABILITY COVERAGE PART

SCHEDULE

Name of Person(s) or Organization(s):

Any person or organization for whom you have agreed by written contract to furnish this waiver.

The TRANSFER OF RIGHTS OF RECOVERY AGAINST OTHERS TO US Condition (Section IV – COMMERCIAL GENERAL LIABILITY CONDITIONS) is amended by the addition of the following:

We waive any right of recovery we may have against the person or organization shown in the Schedule above because of payments we make for injury or damage arising out of your ongoing operations or “your work” done under a contract with that person or organization and included in the “products-completed operations hazard”. This waiver applies only to the person or organization shown in the Schedule above.

Nothing herein contained shall be held to vary, alter, waive or extend any of the terms, conditions, provisions, agreements or limitations of the mentioned Policy, other than as above stated.

This endorsement changes the policy to which it is attached and is effective on the date issued unless otherwise stated.
(The information below is required only when this endorsement is issued subsequent to preparation of the policy.)

Endorsement Effective: **Same as policy effective date unless otherwise indicated above.**

Policy Effective Date: 6/1/2020

Policy No.: GL20A00047

Endorsement No.:

Insured: Sukut Construction, LLC

Premium \$

Insurance Company: American Contractors Insurance Co RRG

GENERAL PROVISIONS

GENERAL PROVISIONS

or contract change orders are written agreements executed by the Contractor and by the District, covering alterations, amendments or extensions to the project, as hereinafter provided.

(j) CONTRACT: The written agreement covering the performance of the work and the furnishing of labor and materials in the construction of the work. The contract shall include the Notice to Contractors, the Proposal, Plans, Specifications, Special Provisions, and Contract Bonds, also, any and all supplemental agreements or contract change orders amending or extending the work contemplated and which may be required to complete the work in a substantial and acceptable manner.

(k) CONTRACT PRICE: Shall mean either the lump sum, unit price, or unit prices to be named in the contract, or the total of all payments under the contract at the lump sum, unit price, or unit prices, as the case may be.

(l) SURETY OR SURETIES: The bondsmen or party or parties, approved by the Engineer, who may guarantee the fulfillment of the contract by bond, and whose signatures are attached to said bond.

(m) RIGHT OF WAY: The whole right of way which is reserved for and secured for use in constructing the improvement.

(n) THE WORK: All the work specified in the Specifications and Contract Documents, including the Special Provisions, proposal and contract, or indicated on the plans as the contemplated complete improvement covered by the contract.

1.02 SIMILARITY OF WORDS. Wherever in the specifications or upon the plans the words directed, required, permitted, ordered, designated, prescribed, or words of like import are used, it will be understood that the direction, requirements, permission, order, designation, or prescription of the Flood Control Engineer is intended, and similarly the words approved, acceptable, satisfactory, or words of like import, shall mean approved by, or acceptable to, or satisfactory to, the Flood Control Engineer, unless otherwise expressly stated.

SECTION II - SCOPE OF WORK

2.01 WORK TO BE DONE

It is the intent of these General Provisions, Special Provisions, Detailed Specifications, and the plans herein referred to, that the Contractor shall provide all labor, power, light, water, materials, equipment, tools, scaffolding, machinery, transportation, insurance, permits, bonds, temporary protection, watchmen, and superintendence necessary to construct and complete all work, and to furnish all materials included in the contract, except those furnished by the District and as specifically mentioned in these specifications.

The contract documents are complementary, and the work called for by any one shall be as binding as if called for by all.

2.02 CONSTRUCTION SCHEDULE

The Contractor shall submit at such times as may be requested by the Engineer, a schedule which shall show the order and dates in which the Contractor proposes to carry on the various parts of the work; including estimated completion dates. The District's receipt of such schedule(s) shall not indicate any concurrence by the District in the items or dates described in the schedule(s).

2.03 DRAWINGS AND SPECIFICATIONS ON THE WORK

The Contractor shall keep one copy of all drawings and specifications on the work, in good order, available to the Engineer and his representatives.

2.04 ESTIMATE OF QUANTITIES

The quantities of work to be done and the materials to be furnished under this contract are approximate only. The District is not to be held responsible for the accuracy of the estimate of quantities.

The Contractor shall judge for himself, after considering all circumstances and conditions, the costs and quantities of materials involved in the contract. The Contractor shall not at any time assert that there was any misunderstanding in regard to the depth or class of the excavations to be made, or the nature or kind or amount of materials to be furnished for the work.

The Contractor shall not at any time assert that there was any misunderstanding in regard to the nature of the work or the kind or amount of materials to be furnished for the work. The Contractor herewith agrees that he will not ask, demand, sue for, or seek to recover, for compensation in excess of the amounts payable for the various unit costs or lump sum charges for the work, as stipulated in the proposal, which he actually performs as specified.

2.05 PROTESTS

If the Contractor considers any work demanded of him to be outside of the requirements of the contract, or considers any record or ruling of the Engineer to be unfair, he shall immediately, upon such work being demanded or such record of ruling being made, ask, in writing, for written instructions covering protested items of work. Immediately on receipt of written instructions from the Engineer he shall proceed without delay to diligently perform the work in conformance with the written record or ruling. Immediately upon receipt of the written instructions or ruling and before the start of such work, and no later than five (5) business days, the Contractor shall file a written protest with the Engineer stating clearly and in detail the basis of his protest. Except for such protests as are made of record in the manner herein specified and within the time limit stated, the records, rulings, instructions, or decisions of the Engineer shall be final and conclusive.

2.06 ALTERATIONS

The Contractor understands and agrees that such reasonable alterations and modifications may be made by the Chief Engineer, as may be deemed desirable, and that this may be done without notices to the Sureties on the Contractor's bonds. If such changes result in increased or decreased quantities under the items specified in the Agreement, the Contractor will be paid on the

basis of actual quantities as measured by the Engineer, and such changes shall not affect the unit prices bid by the Contractor. If, however, such changes result in delay to the work, the Contractor may request an extension of time on the completion of his contract and the Chief Engineer may grant such extension as the Chief Engineer may deem equitable.

2.07 EXTRA WORK

A. General

The District reserves and shall have the right, for any reason whatsoever, or when confronted with unpredicted conditions, unforeseen events, or emergencies, to revise the details of the contemplated work, or to add work of a different character or function and have the Contractor perform such revised or added work as "Extra Work", when such extra work is considered by the Chief Engineer to be appurtenant to the satisfactory completion of the project.

"Extra Work" is defined as added work of a different character or function and for which no basis for payment is prescribed; or that involving revisions of the details of the work in such manner as to render inequitable payment under items upon which the Contractor bid; or that work which is indeterminate at the time of advertising and is specifically designated as extra work in the plans and Special Provisions.

The signing of the contract by the Contractor will be deemed to be an agreement on his part to perform extra work, as and when ordered by the Chief Engineer. Notice to the Sureties on the Contractor's bonds will not be given unless the estimated total value of the contract, as changed or supplemented, shall exceed the original total bid price by more than 25%.

If required extra work results in delay to the work, the Contractor will be given an equivalent extension of time.

Approval of extra work shall be obtained from the Board of Supervisors before such work is authorized to be done, if:

- a. For contracts with a total contract price of \$250,000 or less, a change due to extra work exceeds ten percent (10%) of the original contract amount; or
- b. For contracts with a total contract price of more than \$250,000, a change due to extra work exceeds \$25,000 plus one percent (1%) of the original contract amount in excess of \$250,000; or
- c. An individual change exceeds \$100,000; or
- d. Cumulative contract changes exceed ten percent (10%) of the original contract amount.

Extra work specially authorized by the Board of Supervisors shall not be included in the cost limitations above stated.

B. Procedure for Extra Work

1. Extra work may not be done by the Contractor without prior request and proper written approval by the District. Upon decision of the District to have extra work performed, the Chief Engineer will so inform the Contractor, acquainting him with the essential details of the new work. The Contractor shall thereupon present in writing a price for said work based upon his estimate of cost and submit said price and estimate to the Chief Engineer whose approval shall be secured before work is started; excepting that the Chief Engineer may, when in the best interest of the District, order the Contractor to proceed with the extra work in advance of the submission of such prices, provided that preliminary estimates, as made by the District, show that the cost will not exceed \$1,000.

2. Prices for extra work shall be prepared by the Contractor on one or both of the following methods, as requested by the District, and submitted to the Chief Engineer for approval:

a. For a stated unit price or lump sum amount based upon current prevailing fair prices for materials, labor, plant, overhead and profit.

b. On a cost basis (force account by the Contractor). The cost of all work done by the Contractor will be computed in the manner described in Section 7.03, and the compensation thus provided shall be accepted as payment in full by the Contractor, and no additional payment will be allowed for the use of small tools, superintendent's and foreman's services, timekeeper's services, pickup or yard trucks, except as specifically essential to the work, nor any other overhead expenses incurred in the prosecution of the force account work.

3. Upon receipt of the Contractor's price, the Chief Engineer will make an analysis thereof and adopt one of the following procedures:

a. Accept the Contractor's price for lump sum or unit price amount in the original or amended form and direct him to proceed with the work; or direct him to perform the work on a cost plus basis.

b. Have the work performed by District's forces or separate contract, without undue interference or hindrance to the Contractor and without claim or suit by the Contractor for damages on account thereof.

c. Direct the Contractor to proceed with the work and accept payment therefor in the amount as adjudicated later in a court of law.

4. The price agreed to by the Contractor for the extra work shall be full compensation to the Contractor for all labor, materials, equipment or other costs related to the extra work.

2.08 PAYMENT FOR EXTRA WORK

At the end of each month the Contractor shall make and deliver to the Chief Engineer a statement of the cost of the extra work completed during the current month, itemized and in a form

satisfactory to the Chief Engineer. Upon verification of said statement by the Chief Engineer, the Contractor's claim for the full amount, as shown on said statement, will be added to the monthly partial payment made in accordance with Paragraph 7.06 of the General Provisions.

2.09 RIGHTS OF WAY

The District shall provide the rights of way upon which the work under this contract is to be done, except that the Contractor shall provide land required for the erection of temporary construction facilities and storage of his material, together with right of access to same. The District will not be responsible for any delay in furnishing the rights of way and such delay shall not be made the basis for a claim for additional compensation by the Contractor. However, in case the failure of the District to furnish the required rights of way delays the prosecution of the work, the time allowed for completion will be extended by a period of time equal to that lost by the Contractor due to such delay.

2.10 CLEANING UP

The Contractor shall, as directed by the Engineer, remove from the District's right of way and from all public and private property, at his own expense, all temporary structures, rubbish and waste materials resulting from his operations.

SECTION III - CONTROL OF THE WORK

3.01 AUTHORITY OF THE ENGINEER

The Engineer shall have general supervision and direction of the contract under authority of the Board of Supervisors. He has the authority to stop the work whenever such stoppage may be necessary to ensure the proper execution of the contract. The Engineer shall decide all questions which may arise as to the quality or acceptability of materials furnished, work performed, and rate or progress of the work; all questions which may arise as to the interpretation of the plans and specifications; all questions as to the acceptable fulfillment of the contract on the part of the Contractor; and all questions as to compensation.

His determination and decision thereon shall be final and conclusive; and such determination and decision, in case any question shall arise, shall be a condition precedent to the right of the Contractor to receive any money hereunder.

3.02 DETAIL DRAWINGS

The approved plans shall be supplemented by such working drawings as are necessary to control the work adequately. All authorized alterations affecting the requirements and information given on the approved plans shall be in writing. No changes shall be made of any plan or drawing after the same has been approved by the Engineer, except by his direction.

It is expressly understood, however, that approval by the Engineer of the Contractor's working drawings does not relieve the Contractor of any responsibility for accuracy of dimensions and details. It is mutually agreed that the Contractor shall be responsible for agreement and conformity of his working drawings with the approved plans and specifications.

Full compensation for furnishing all working drawings shall be considered as included in the prices paid for the various contract items of work, and no additional allowance will be made therefor.

3.03 CONFORMITY WITH PLANS AND ALLOWABLE DEVIATIONS

Finished surfaces in all cases shall conform with the elevations, lines, grades, cross-sections, and dimensions shown on the approved plans or as described in the Specifications and Contract Documents. Deviations from the approved plans and working drawings, will in all cases be in the Engineer's discretion and as determined by the Engineer and preauthorized in writing.

3.04 INTERPRETATION OF PLANS AND SPECIFICATIONS

Should it appear that the work to be done or any of the matters relative thereto are not sufficiently detailed or explained in these specifications and the Special Provisions, the Contractor must bring this to District's attention in writing and shall apply to the Engineer for such further explanations as may be necessary and shall conform to the same part of the contract, so far as may be consistent with the original specifications; and in the event of any doubt or questions arising respecting the true meaning of the specifications; reference shall be made to the Engineer, whose decision thereon shall be final. The requirements in this Section 3.04 shall also apply during the bidding process and before submittal of the Contractor's Proposal.

In the event of any discrepancy between any drawings and the figures written thereon, the figures shall be taken as correct. The Contractor will not be allowed to take advantage of errors and omissions in the drawings and specifications. When errors or omissions are found, they will be corrected or supplied by the Engineer.

3.05 SUPERINTENDENCE

The Contractor shall keep on his work, continually during its progress, a competent Superintendent responsible for the construction of the work, and any necessary assistants; all satisfactory to the Engineer. All such persons shall be acceptable to the District continuously throughout the duration of the Project. The Superintendent shall represent the Contractor in his absence and all directions given to him shall be as binding as if given to the Contractor. Important directions shall be confirmed in writing to the Contractor. Other directions shall be so confirmed on written request in each case.

3.06 LINES AND GRADES

The Contractor shall provide reasonable and necessary opportunities and facilities for setting points and making measurements. He shall not proceed until he has made timely demand upon the Engineer for, and has received from him, such lines and grades as may be necessary as the work progresses. The work shall be done in strict conformity with such lines and grades.

The Contractor shall carefully preserve benchmarks, reference points and stakes, and in case of willful or careless destruction, he shall be charged with the resulting expense and shall be responsible for any mistakes that may be caused by their unnecessary loss or disturbance.

3.07 INSPECTION OF WORK

The Engineer and his representatives shall at all times have access to the work during its construction, and shall be furnished with every reasonable opportunity and facility for ascertaining that the stock and materials used and employed, and the workmanship, are in accordance with the requirements and intentions of these specifications. All work done and all materials furnished shall be subject to the Engineer's inspection and approval to ensure design objectives.

The inspection of the work shall not relieve the Contractor of any of his obligations to fulfill his contracts as prescribed, and defective work shall be made good and unsuitable materials may be rejected, notwithstanding that such defective work and materials have been previously overlooked by the Engineer and accepted or estimated for payment.

3.08 REMOVAL OF DEFECTIVE AND UNAUTHORIZED WORK

All work which has been rejected shall be remedied, or removed and replaced by the Contractor in an acceptable manner and no compensation will be allowed him for such removal or replacement. Any work done beyond the lines and grades shown on the plans or established by the Engineer, or any extra work done without written authority, will be considered as unauthorized and will not be paid for. Work so done may be ordered removed at the Contractor's expense. Upon failure on the part of the Contractor to comply forthwith with any order of the Engineer made under the provisions of this article, the Engineer shall have authority to cause defective work to be remedied, or removed and replaced, and unauthorized work to be removed and to deduct the costs for this work from any monies due or to become due the Contractor.

3.09 EQUIPMENT AND PLANT

Equipment not suitable to produce the quality of work required will not be permitted to operate on the project. Plants shall be designed and constructed in accordance with general practice for such equipment and shall be of sufficient capacity and of such character to ensure the production of sufficient material to carry the work to completion within the time limit.

The Contractor shall provide adequate and suitable equipment and plants to meet the above requirements and, when ordered by the Engineer, shall remove unsuitable equipment from the work and discontinue the operation of unsatisfactory plants. No worn or obsolete equipment shall be used, and in no case shall the maker's rating of the capacity for any equipment be exceeded.

All vehicles used to haul materials over existing highways shall be equipped with pneumatic tires.

3.10 FINAL INSPECTION

The Engineer will not make the final inspection until the work provided for and contemplated by the contract has been completed and the final cleaning up performed.

SECTION IV - CONTROL OF MATERIAL

4.01 DISTRICT FURNISHED MATERIALS

The Contractor shall furnish all materials required to complete the work, except those specified in the Special Provisions to be furnished by the District. Materials furnished by the District will be delivered to the Contractor at the points specified in the Special Provisions.

The Contractor will be held responsible for all materials so delivered to him, and deductions will be made from any monies due him to make good any shortages and deficiencies, from any cause whatsoever, which may occur after such delivery, or for any demurrage charges due to delinquency in unloading.

4.02 SOURCE OF SUPPLY AND QUALITY OF MATERIALS

At the option of the Engineer the source of supply of each of the materials shall be approved by him before the delivery is started. Only materials conforming to the requirements of these specifications and approved by the Engineer shall be used in the work. All materials proposed for use may be inspected or tested at any time during their preparation and use. If, after trial, it is found that sources of supply which have been approved do not furnish a uniform product, or if the product from any source proves unacceptable at any time, the Contractor shall furnish approved material from other approved sources. No material which, after approval, subsequently becomes unfit for use shall be used in the work.

Wherever the name, or brand, or manufacturer of an item is specified, it is used as a measure of quality and utility or a standard. Except in those instances where the product is designated to match others presently in use, or as otherwise stated in the Contract Documents, specifications calling for a designated material, product, thing or service by specific brand or trade name shall be deemed to be followed by the words "or equal" so that the Contractor may propose in the Contractor's bid any equal material, product, thing or service. If the Contractor desires to use any other brand or manufacturer of equal quality or utility to that specified, he shall list definite particulars of that which it considers equivalent to the specified item in its bid. The District will then determine whether or not the proposed name brand or article is equal in quality and utility to that specified, and the District's determination in that regard shall be final and binding upon the Contractor.

4.03 SAMPLES AND TESTS

All tests of materials furnished by the Contractor shall be made by the District in accordance with commonly recognized standards of national organizations, and such special methods and tests as are in use at the District's approved laboratory and described in the Detailed Specifications.

Field tests of materials will also be made by the Engineer when deemed necessary and these tests shall be made in accordance with standard practices of the District.

The Contractor shall furnish such samples of all materials as are requested by the Engineer without charge. No material shall be used until it has been approved by the Engineer. Samples will be secured and tested whenever necessary to determine the quality of the material.

Promptly after the approval of the contract, the Contractor shall notify the Engineer of the proposed sources of supply of all materials to be furnished by him, using a form which will be supplied by the Engineer upon request.

Whenever reference is made in these specifications to standard tests or requirements of the laboratory of the District, the American Society for Testing Materials, the American Railway Engineering Association, or the American Association of State Highway Officials, the reference shall be construed to mean the standards that are in effect at the date of these specifications with subsequent amendments, changes, or additions as thereafter adopted and published by the organization referred to.

4.04 DIGGING TRENCHES OR OTHER EXCAVATIONS

Any work that involves digging trenches or other excavations extending deeper than four feet below the surface, then the following terms shall apply:

4.04.1 Contractor shall promptly, and before the following conditions are disturbed, notify the District, in writing, of any:

- 4.04.1.1 Material that the Contractor believes may be material that is hazardous waste, as defined in Section 25117 of the Health and Safety Code, that is required to be removed to a Class I, Class II, or Class III disposal site in accordance with provisions of existing law.
- 4.04.1.2 Subsurface or latent physical conditions at the site differing from those indicated by information about the site made available to bidders prior to the deadline for submitting bids.
- 4.04.1.3 Unknown physical conditions at the site of any unusual nature, different materially from those ordinarily encountered and generally recognized as inherent in work of the character provided for in the contract.

4.04.2 The District shall promptly investigate the conditions, and if it finds that the conditions do materially so differ, or do involve hazardous waste, and cause a decrease or increase in the Contractor's cost of, or the time required for, performance of any part of the work shall issue a change order under the procedures described in the contract.

4.04.3 In the event that a dispute arises between the District and the Contractor whether the conditions materially differ, or involve hazardous waste, or cause a decrease or increase in the Contractor's cost of, or time required for, performance of any part of the work, the Contractor shall not be excused from any scheduled completion date provided for by the contract, but shall proceed with all work to be performed under the contract. The Contractor shall retain any and all rights provided either by contract or by law which pertain to the resolution of disputes and protests between the contracting parties.

4.04.4 Contractor shall submit to District, in advance of excavation, a detailed plan showing the design of shoring, bracing, sloping, or other provisions to be made for worker protection from the hazard of caving ground during the excavation of such trench or trenches. Prior to any excavation is commenced, District shall accept said plan. If such plan varies from the shoring system standards, the plan shall be prepared by a registered civil or structural engineer.

4.04.5 Nothing in this section shall be deemed to allow the use of a shoring, sloping, or protective system less effective than that required by the Construction Safety Orders.

4.04.6 Nothing in this section shall be construed to impose tort liability on the awarding body or any of its employees.

4.05 STORAGE OF MATERIALS

Materials shall be so stored as to ensure the preservation of their quality and fitness for the work. When considered necessary by the Engineer, they shall be placed on wooden platforms or other hard, clean surfaces and not on the ground. They shall be placed under cover when so directed. Stored materials shall be so located as to facilitate prompt inspection.

4.06 DEFECTIVE MATERIALS

All materials not conforming to the requirements of these specifications shall be considered as defective and all such materials, whether in place or not, shall be rejected and shall be removed immediately from the site of the work unless otherwise permitted by the Engineer. No rejected materials, the defects of which have been subsequently corrected, shall be used until approval in writing has been given by the Engineer. Upon failure on the part of the Contractor to comply forthwith with any order of the Engineer made under the provisions of this article, the Engineer shall have authority to remove and replace defective material and to deduct the cost of removal and replacement from any monies due or to become due the Contractor.

4.07 ASSIGNMENT OF CLAIMS

In submitting a bid on this public works project, or any subcontractor agreeing to supply goods, services, or materials, and entering a contract pursuant thereto, the Contractor and/or subcontractor do offer and agree to assign to the District all rights, title, and interest in and to all causes of action it may have under Section 4 of the Clayton Act (15 U.S.C. Section 15) or under the Cartwright Act (Chapter 2 (commencing with Section 16700) of Part 2 of Division 7 of the Business and Professions Code), arising from purchases of goods, services, or materials pursuant to the public works contract or the subcontract. This assignment shall be made and become effective at the time the awarding body tenders final payment to the Contractor, without further acknowledgment by the parties.

SECTION V - LEGAL RELATIONS AND RESPONSIBILITY

5.01 LAWS TO BE OBSERVED

(a) Compliance with Applicable Law. Reference to and/or incorporation into the Contract Documents of a particular law, statute, ordinance, rule or regulation is not, nor is it

intended to be, a definitive statement of the law applicable to the Contract Documents and the accomplishment of the work. Contractor must keep informed as to all such applicable law - Federal, State, County, Municipal, District - as it affects the conduct of the work and comply with such law, including, but not limited to, having requisite licenses, obtaining necessary permits, paying necessary fees and taxes, posting notices and installing, operating and maintaining safety precautions and facilities. It is likewise Contractor's responsibility to see to it that his subcontractors also fully comply with such applicable law.

If at any time Contractor is of the opinion that there is a discrepancy or inconsistency in the plans, drawings, specifications or other Contract Documents, he shall immediately cease work involving such alleged discrepancies or inconsistencies and report the same in writing to the Chief Engineer and shall not proceed with such work until ordered so to do, and in the manner instructed by the Chief Engineer.

Contractor shall protect and defend District, its officers, agents and employees against any claim or liability arising from or based upon any alleged violation of such applicable law. See also Subsection 8.02.

(b) Labor Code - The Contractor shall comply with all applicable requirements of the California Labor Code including but not limited to Labor Code, Chapter 2, Subchapter 1, Article 10, Required Apprentices on Public Works Contracts. Reference is made to Chapter 1, Part 7, Division 2 of the California Labor Code (commencing with Section 1720). By this reference said Chapter 1 is incorporated herein with like effect as if it were here set forth in full. The parties recognize that said Chapter 1 deals with, among other things, discrimination, penalties and forfeitures, their disposition and enforcement, wages, working hours and securing workers' compensation insurance and directly affect the method of prosecution of the work by Contractor and subject it under certain conditions to penalties and forfeitures. Execution of the Agreement by the parties constitutes their agreement to abide by said Chapter 1. Their stipulation as to all matters which they are required to stipulate as to by the provisions of said Chapter 1, constitutes Contractor's certification that it is aware of the provisions of said Chapter 1 and will comply with them and further constitutes Contractor's certification as follows: "I am aware of the provisions of Section 3700 of the California Labor Code which requires every employer to be insured against liability for workers' compensation or to undertake self-insurance in accordance with the provisions of that Code, and I will comply with such provisions before commencing the performance of the work of this contract." Contractor and its subcontractors shall comply with the provisions of S1777.5 of the Labor Code regarding apprentices.

Contractor shall post at each job site during the course of the work a copy of District's "Determination of Prevailing Wage Rates", copies of said Determination are available from District for this purpose and at <http://www.dir.ca.gov/OPRL/DPreWageDetermination.htm>.

(c) Equal Employment Opportunity

General - The Contractor shall comply with all applicable non-discrimination and equal employment laws. The Contractor shall not discriminate in its recruiting, hiring, promotion, demotion or termination practices on the basis of race, religious creed, color, national origin, ancestry, sex, age or physical handicap in the performance of this Contract and shall comply with the provisions of the California Fair Employment Practice Act (commencing with Section 1410 of

the Labor Code), the Federal Civil Rights Act of 1964 (P.L. 88-352) and all amendments thereto, Executive Order No. 11246 (30 Federal Register 12319), as amended, and all administrative rules and regulations issued pursuant to said Acts and Order. See particularly 41 Code of Federal Regulation (CFR) Chapter 60.

Contractor shall require each of its subcontractors to comply with the preceding paragraph and shall include in each subcontract language similar to the preceding paragraph.

Contractor shall permit access to its records of employment, employment advertisement, application forms and other pertinent data and records (including but not limited to certified payroll information) by District and any state or federal agency having jurisdiction for the purpose of investigation to ascertain compliance with this Section.

District may assign an affirmative action representative to monitor Contractor and its subcontractor(s) conduct required by this Section, including the right of entry to the construction site for the purpose of obtaining information from persons performing work on the project providing such inspection does not interfere with the progress of the work.

Elsewhere in the Contract Documents specific requirements may be contained covering the same subject matter of this Section. If so, such specific requirements prevail over this Section in case of conflict.

Transactions of \$10,000 or under - Contracts and subcontracts not exceeding \$10,000 are exempt from the requirements of this Section. No Contractor or subcontractor shall procure supplies and/or services in less than usual quantities to avoid applicability of this Section. With respect to contracts and subcontracts for indefinite quantities, this Section applies unless the amount required in any one year under such contract will reasonably be expected not to exceed \$10,000.

Transactions in Excess of \$10,000 but less than \$50,000 - At District's request, Contractor shall certify that it has in effect an affirmative action plan and agrees to comply with all state and federal laws and regulations regarding Fair Employment Practices. Contractor shall maintain a written copy of its affirmative action plan and furnish District a copy of the plan upon request. District may require Contractor to complete an Affirmative Action Compliance Report, on a form furnished by District, setting forth definite goals during the term of this contract.

Transactions of \$50,000 or more - If Contractor has 50 or more employees and a contract for \$50,000 or more, it shall develop and submit to District, within 30 days after award, a written affirmative action compliance program providing in detail specific steps to guarantee equal employment opportunity. Contractor shall include in its affirmative action program a table of job classifications, which table shall include but need not be limited to job titles, duties and rates of pay.

Contractor shall in each subcontract let to do a portion of the work covered hereunder, where the subcontractor involved has 50 or more employees and the subcontract is for \$50,000 or more, impose in the subcontract the above requirements.

For the purpose of determining the number of employees, the average of the Contractor's or its subcontractor's employees for the 12 month period immediately prior to award, or the total number of employees Contractor or its subcontractor will have when performing this contract, whichever is higher, shall be used.

Federally Assisted Construction - If this project is a Federally assisted construction project, then the contract provisions contained 41 CFR S60-1.4(b) are incorporated herein and Contractor shall likewise incorporate said provisions in each subcontract entered into by Contractor to perform the work. Federally assisted construction is identified as such in the Notice Inviting Bids.

(d) Registration of Contractors - In order to be considered a prospective bidder must be licensed in accordance with Division 3, Chapter 9 (commencing with Section 7000) of the Business and Professions Code.

(e) Accident Prevention - Particular attention shall be given to relevant Division of Industrial Safety Construction and Electrical Safety Orders. Said Orders are contained in Title 8 of the California Code of Regulations, Chapter 4, Subchapters 4 and 5. Specific attention shall be taken of the California Occupational Safety and Health Act of 1973 (commencing with Section 6300 of the Labor Code) and the Federal Occupational Safety and Health Act of 1970 (P.L. 91-596) and rules and regulations issued pursuant to said Acts. Specific reference is made to Article 6 of said Construction Safety Orders. Contractor shall submit to Engineer, who will accept in advance of excavation, a detailed plan showing the design of shoring, bracing, sloping of the sides of trenches, or other provisions to be made for protection of personnel during earthwork operations. In event the Contractor's plan does not conform with the shoring system requirements of Article 6, the Contractor's proposed shoring design shall be prepared and signed by a civil or structural engineer registered in the State of California.

The Contractor shall also impose the foregoing requirements on all subcontractors involved and enforce compliance therewith.

The duties here set forth are nondelegable by Contractor who shall protect and defend District, its officers, agents and employees in connection therewith. See Subsection 8.02.

5.02 CONTRACTOR'S RESPONSIBILITY

Contractor is under the absolute duty in fulfilling its contractual obligations hereunder to proceed, and cause its subcontractors to proceed, in a safe, workmanlike manner, with adequate safeguards for the protection of the public, the workmen and persons from time to time inspecting the work. If at any time Contractor finds any of its subcontractors are allowing work to proceed in an unsafe manner and contrary to the intent of these Contract Documents, Contractor shall immediately cause such action to stop and immediately take all action necessary to protect workmen, inspectors and the general public and cause the work to proceed in a safe manner.

Contractor shall protect and defend District, its officers, agents and employees in reference to acts or omissions contrary to the above. See particularly Subsection 8.02.

District may withhold funds otherwise due Contractor whenever, in its judgment, this subsection is not being complied with.

5.03 CONTRACTOR'S RESPONSIBILITY FOR WORK

Until the formal acceptance of the work by the District, the Contractor shall have the charge and care thereof and shall bear the risk of injury or damage to any part thereof by the action of the elements or from any other cause, whether arising from the execution or from the non-execution of the work. The Contractor shall rebuild, repair, restore, and make good all injuries or damages to any portion of the work occasioned by any of the above causes before its completion and acceptance and shall bear the expense thereof, except for such injuries or damages as are occasioned by acts of the Federal Government and the public enemy. In case of suspension of work from any cause whatsoever, the Contractor shall be responsible for all materials and shall properly store them if necessary and shall erect temporary structures where necessary.

5.04 PROPERTY RIGHTS IN MATERIALS

Nothing in the contract shall be construed as vesting in the Contractor any right of property in the materials used after they have been attached or affixed to the work or the soil. All such materials shall become the property of the District upon being so attached or affixed.

5.05 PERMITS AND LICENSES

The Contractor shall procure all permits and licenses, (including but not limited to: National Pollution Discharge Elimination System (NPDES) and South Coast Air Quality Management District (AQMD) permit requirements), pay all charges and fees, and give all notices necessary and incident to the due and lawful prosecution of the work.

5.06 ROYALTIES AND PATENTS

The Contractor shall assume all costs arising from the use of patented materials, equipment, devices, or processes used on or incorporated on the work, and agrees to indemnify and save harmless the Riverside County Flood Control and Water Conservation District, the Board of Supervisors, the Flood Control Engineer, and their duly authorized representatives, from all suits at law, or actions of every nature for, or on account of, the use of any patented materials, equipment, devices, or processes.

5.07 SANITARY PROVISIONS

Necessary conveniences, properly secluded from public observation shall be provided by the Contractor where needed for the use of laborers on the work. Their location, construction and maintenance shall be subject to the approval of the Engineer, and their use shall be strictly enforced. The Contractor shall obey and enforce such sanitary regulations as may be prescribed by the State Department of Health or other authorities having jurisdiction.

5.08 PUBLIC SAFETY

The Contractor at his own expense shall furnish, erect, and maintain such fences, barriers, lights, and signs as are necessary to give adequate warning to the public at all times that the bridges, culverts, and work along public highways are under construction; and of any dangerous conditions to be encountered as a result thereof; and he shall erect such warning and directional signs and employ such flagmen as are required and maintain same throughout the construction period.

Full compensation for the work involved in carrying out the precautionary measures above specified shall be considered as included in the prices paid for the various contract items of work and no additional allowance will be made therefor.

5.09 USE OF EXPLOSIVES

When the use of explosives is necessary for the prosecution of the work, the Contractor shall use the utmost care not to endanger life or property.

All explosives shall be stored in accordance with the provisions of Division II, Part I, Chapter 3, of the Health and Safety Code of the State of California.

5.10 PROVISIONS FOR EMERGENCIES

Unusual conditions may arise on the work which will require that immediate and unusual provisions be made to protect the public from danger or loss or damage to life and property, due directly or indirectly to the prosecution of the work, and it is part of the service required of the Contractor to make such provisions and to furnish such protection.

The Contractor shall use such foresight and shall take such steps and precautions as his operations make necessary to protect the public from danger or damage, or loss of life or property, which would result from the interruption or contamination of public water supply, irrigation or other public service, or from the failure of partly completed work.

Whenever work is undertaken pursuant to the above provisions, Contractor shall promptly file with District a verified report setting forth the nature of the emergency and the action taken by the Contractor by reason of the emergency.

Whenever, in the opinion of the Engineer, an emergency exists against which the Contractor has not taken sufficient precaution for the safety of the public or the protection of utilities or of adjacent structures or property which may be injured by process of construction on account of such neglect; and whenever, in the opinion of the Engineer, immediate action shall be considered necessary in order to protect public or private, personal or real property interests, or prevent likely loss of human life or damage on account of the operations under the contract, then and in that event the Engineer may provide suitable protection to said interests by causing such work to be done and material to be furnished as, in the opinion of the Engineer, may seem reasonable and necessary.

The cost and expense of all such emergency work shall be borne by the Contractor, and if he shall not pay said cost and expense upon presentation of the bills therefor, duly certified by the

Engineer, then said cost and expense will be paid by the District and shall thereafter be deducted from any amounts due, or which may become due said Contractor. Failure of the District, however, to take such precautionary measures, shall not relieve the Contractor of his full responsibility for public safety.

5.11 UNFORESEEN DIFFICULTIES

All loss or damages, except as noted in Section 8.03, arising out of the nature of the work to be done under the contract, or from any unforeseen obstructions or difficulties which may be encountered during the progress of the work and in the prosecution of the same, or from the action of the elements, or from encumbrances in the line of work, shall be sustained by the Contractor.

5.12 ACCESS TO THE WORK

Access to the work from existing roads shall be provided by the Contractor at his expense and maintained in a manner so as not to create a public nuisance. The Board of Supervisors, Flood Control District and Engineer assume no responsibility for the condition or maintenance of any existing road or structure thereon that may be used by the Contractor for performing the work under these specifications and for traveling to and from the site of the work. No direct payment will be made to the Contractor for constructing temporary roads used for construction operations or for improving, repairing, or maintaining any existing road or structure thereon that may be used by the Contractor for performance of the work under these specifications. The cost of all work described in this paragraph shall be included in the prices bid in the schedule for other items of construction work.

5.13 GUARANTEE OF WORK

All work is guaranteed by Contractor for a period of one year from the recordation of the Notice of Completion against defects resulting from the use of inferior materials, equipment, or workmanship. Upon notice from District, Contractor shall promptly remedy such defects at his expense, including payment to District of its expenses in connection with remedying such defects, otherwise District shall proceed to remedy such defects and Contractor shall upon demand reimburse District for its expenses in connection therewith.

The above one year guarantee is in addition to any specific guarantee(s) provided for elsewhere in the Contract Documents.

The performance of guarantee and conditions specified in Section 5.13., shall be secured by a surety bond which shall be delivered by the Contractor to the District prior to the date on which final payment is made to the Contractor. Said bond shall be in an approved form and executed by a surety company or companies satisfactory to the District, in the amount of 10% of the final contract price. Said bond shall remain in force for the duration of the guarantee period specified in Section 5.13. Instead of providing such a bond as described above, the Contractor may, at its option, provide for the performance bond furnished under the contract to remain in force for said amount until the expiration of said guarantee period; and the amount of said performance bond may be reduced to 10% of the final contract price beginning at the time of recordation of the Notice of Completion.

5.14 DAMAGES BY ACT OF GOD

If the construction of the project herein is damaged, which damage is determined to have been proximately caused by an act of God, in excess of 5% of the contract amount, provided that the work damaged is built in accordance with applicable building standards and the plans and specifications, then the District, may, without prejudice to any other right or remedy, terminate the contract.

SECTION VI - PROSECUTION AND PROGRESS

6.01 PROGRESS OF THE WORK

The Contractor shall begin the work within ten (10) calendar days after the date of the receipt by him of notice to proceed from the Chief Engineer and shall diligently and continuously prosecute the same to completion within the time limit provided in the Special Provisions.

6.02 OVERTIME WORK AND WORK AT NIGHT

It is intended that the Contractor prosecute the work on a five (5) day, forty (40) hour work week with no work on legal holidays. If the Contractor feels it is necessary to work more than the normal forty (40) hour work week, he will make a written request for permission from the Engineer, outlining the reasons for such request. The decision of granting permission for overtime work shall be made by the Engineer and shall be final. A condition will be imposed on the granting of a request to work overtime, requiring the Contractor to pay the District the cost incurred at overtime rates for additional inspection and engineering time required in connection with the overtime work.

When any work is performed at night, only such classes of work shall be done as can be properly inspected. Adequate light must be provided for the safety of the workers and for proper inspection.

6.03 SUBCONTRACTING

Reference is made to the Subletting and Subcontracting Fair Practice Act contained in the Public Contract Code (commencing §4100). By this reference, said Act is incorporated herein with like effect as if it were here set forth in full and the parties shall abide by its terms and substitution shall be only as allowed by that Act.

Contractor shall be responsible for the acts and omissions of its subcontractors and shall make certain that at all times its subcontractors comply with the terms of the Contract Documents and applicable law insofar as such compliance relates to the work.

District reserves the right to approve all subcontractors whether or not they are required to be listed in the Contractor's Proposal. As used in this Section "subcontractor" includes any person who fabricates or manufactures any article for incorporation into the work whether or not they install or test after installation or contract to install or test after installation, but does not include suppliers of fungible goods for incorporation into the work unless such supplier also installs or tests or contracts to install or test.

The Contractor shall give his personal attention to the fulfillment of the contract and shall keep the work under his control. The Contractor shall perform with his own organization work of a value amounting to not less than 60% of the remainder obtained by subtracting from the total original contract value the sum of any item designated herein or in the Special Provisions as Specialty Items. The furnishing and placing of reinforcing steel, when placing is performed by the supplier, will be considered as a Specialty Item for this purpose; however, he shall be designated in the list of subcontractors. The value of the work subcontracted will be based on the contract item bid price. When a portion of an item is subcontracted, the value of work subcontracted will be based on the estimated percentage of the Contract Unit Price. This will be determined from information submitted by the Contractor, and subject to approval by the Engineer.

Where a portion of the work which has been subcontracted by the Contractor is not being prosecuted in a manner satisfactory to the District, the subcontractor shall be removed immediately on the requisition of the Engineer and shall not again be employed on the work.

6.04 CHARACTER OF WORKMEN

If any subcontractor or person employed by the Contractor shall fail or refuse to carry out the directions of the Engineer or shall appear to the Engineer to be incompetent or to act in a disorderly or improper manner, he shall be discharged immediately on the requisition of the Engineer, and such person shall not again be employed on this work.

6.05 TEMPORARY SUSPENSION OF THE WORK

The Engineer shall have the authority to suspend the work wholly or in part, for such period as he may deem necessary, due to unsuitable weather, or to such other conditions as are considered unfavorable for the suitable prosecution of the work, or for such time as he may deem necessary due to the failure on the part of the Contractor to carry out orders given, or to perform any provision of the contract. The Contractor shall immediately comply with the written order of the Engineer to suspend the work wholly or in part. The work shall be resumed when conditions are favorable and methods are corrected, as ordered or approved in writing by the Engineer.

6.06 TIME OF COMPLETION AND DAMAGES

The Contractor shall complete the work called for under the contract in all parts and requirements within the number of working days specified in the Special Provisions. Liquidated damages shall apply as stated in the Special Provisions and the Contract Documents.

A working day is hereby defined as any day; except Saturdays, Sundays, and legal holidays and days on which the Contractor is specifically required by the Special Provisions to suspend construction operations; on which the Contractor is not prevented by inclement weather or conditions resulting immediately therefrom adverse to the current controlling operation or operations, as determined by the Engineer, from proceeding with at least 60% of the normal labor and equipment force engaged in such operation or operations for at least five hours toward completion of such operation or operations.

The Engineer will furnish the Contractor a weekly statement showing the number of working days charged to the contract for the preceding week, the number of working days specified

for completion of the contract, and the number of working days remaining to complete the contract. The Contractor will be allowed one week in which to file a written protest setting forth in what respects said weekly statement is incorrect, otherwise the statement shall be deemed to have been accepted by the Contractor as correct.

The following holidays will be considered as legal holidays: New Year's Day; Martin Luther King Jr.'s Birthday, Lincoln's Birthday; Washington's Birthday; Memorial Day; Independence Day; Labor Day; Columbus Day; Veteran's Day; Thanksgiving Day; Christmas; and such other days as are declared holidays by ordinance passed by the Board of Supervisors of the District.

Contractor acknowledges that failure to perform in strict accordance with the Contract Documents and within the time limit specified in the Special Provisions will cause District to suffer special damages in addition to cost of completion of the work in accordance with the provisions of the Contract Documents. Such special damage could include, but is not limited to, lease and rental cost, additional salaries and overhead, interest during construction, attorney expense, additional engineering, inspection expense, cost of maintaining or constructing alternate facilities and injury to the property of the District or others. The daily cost to the District for inspection and superintendence by the District shall be the amount specified in the Special Provisions. The District may withhold from any money due or that may become due the Contractor under the contract, such amount as the District may elect to offset the damages incurred and any withholding or failure to withhold shall not in any way limit recovery for damages actually incurred.

It is further agreed that in case the work called for under the contract is not finished and completed in all parts and requirements within the time specified, the Board of Supervisors shall have the right to extend the time for completion or not, as may seem best to serve the interest of the District, and if it decides to extend the time limit for the completion of the contract, it shall further have the right to charge to the Contractor, his heirs, assigns or sureties and to deduct from the final payment for the work all or any part, as it may deem proper, of the actual cost of engineering, inspection, superintendence, and other overhead expenses which are directly chargeable to the contract, and which accrue during the period of such extension, except that cost of final surveys and preparation of final estimate shall not be included in such charges.

The Contractor shall not be assessed damages nor the cost of engineering and inspection during any delay in the completion of the work caused by acts of God or of the public enemy, acts of the District, encountering unknown utility facilities, fire, floods, epidemics, quarantine restrictions, strikes, freight embargoes, and severe weather or delays of subcontractors due to such causes, provided that the Contractor shall notify the Engineer in writing of the causes of delay within 10 days from the beginning of any such delay, and his findings of the facts thereon shall be final and conclusive. Contractor shall not be assessed damages for delay in the completion of the project, when such delay was caused by the failure of the District or the owner of the utility facilities.

The term "severe weather" shall be construed to mean only such weather as is unreasonable or extraordinary and in the opinion of the Engineer, the work could not be prosecuted by the Contractor during the period throughout which such weather prevailed.

6.07 DELAYS AND EXTENSION OF TIME

If delays are caused by unforeseen causes beyond the control of either the Contractor or the District, such as war, strikes, fire, floods, or other action of the elements, such delays will entitle the Contractor to an equivalent extension of time for the completion of the contract, but the Contractor shall not be entitled to damages or additional payments over and above the contract price due to delay caused by any of the above-mentioned causes. Furthermore, if the Contractor suffers any delay caused by the failure of the District to furnish the necessary right of way or materials agreed to be furnished by it, or by failure to supply necessary plans or instructions concerning the work to be done after written request therefor has been made, the Contractor shall be entitled to an extension of time equivalent to the time lost for any of the above-mentioned reasons, but shall not be entitled to any damages for such delay.

6.08 ASSIGNMENT

The contract may be assigned only upon written consent of the District. Such written consent to sublet, assign or otherwise dispose of any portion of the contract, shall not be construed to relieve the Contractor of any responsibility for the fulfillment of the contract.

6.09 TERMINATION OF CONTRACT

Subject to all applicable provisions of these specifications and/or the contract to be entered into hereunder, the Engineer is hereby empowered to direct the time and rate of delivery of materials at the site of work and to direct the time, rate and sequence of work. If the Contractor fails to begin delivery of material and equipment or to commence work within the time specified herein, and/or in the contract, or to maintain the rates of delivery of materials, or to execute the work in the manner and at such locations as directed by the Engineer, or fails to maintain a program of work in such a manner as will, in the judgment of the Engineer inure to interests of the District, or, if in the judgment of the Engineer, the Contractor is not carrying out the provisions of the contract in their true intent and meaning, written notice by the Chief Engineer may be served upon him and the Surety on his faithful performance bond demanding a satisfactory compliance with the contract, and with these specifications. If the Contractor and/or his Surety refuses or neglects to comply with such notice within five (5) days after receiving same, or after commencing so to do, fails to continue so to do, or has assigned or sublet the contract without the consent of the District, then the District may exclude him from the premises and take possession thereof, together with all material and equipment thereon, and may complete the work itself, either by force account or by letting the unfinished portion of the work to another Contractor or by a combination of such methods. In any event, the cost of the completion of said work shall be a charge against the Contractor and his Surety and may be deducted from any money due or becoming due from the District, and if the sums due under the contract are insufficient, said Contractor and/or his Surety shall pay to the District within five (5) days after the completion of the work all of such cost in excess of the contract price.

The Surety, in the event that it assumes part of the work, shall take the Contractor's place in this contract in all respects for that part and shall be paid by the District for all work performed by it in accordance with the terms of this contract. If the Surety assumes the entire contract, all monies remaining due the Contractor at the time of his default shall be made payable to the Surety as the work progresses, subject to the terms of the contract.

SECTION VII - PAYMENT

7.01 SCOPE OF PAYMENTS

The Contractor shall accept compensation, as herein provided, in full payment for furnishing all materials, labor, tools, and equipment necessary to the completed work and for performing all work contemplated and embraced under the contract; also for loss or damage arising from the nature of the work, or from the action of the elements, except as hereinbefore provided, or from any unforeseen difficulties which may be encountered during the prosecution of the work until the final acceptance by the Board of Supervisors; and for all risks of description connected with the prosecution of the work, also for all expenses incurred in consequence of the suspension or discontinuance of the work as herein specified; and for completing the work according to the plans and specifications. Neither the payment of any estimate nor of any retained percentage shall relieve the Contractor of any obligation to make good any defective work or material.

7.01A Measurement and Computation of Quantities - All items of the work to be paid for at a contract price per unit of measurement will be measured by the Engineer in accordance with United States Standard Measures. A ton shall mean 2,000 pounds, avoirdupois. Except as otherwise expressly provided in the specifications, the methods of measurement and computation of quantities of such items will be determined by the Engineer, taking into account the price of the item relative to its quantity and the costs of measurement.

The weights of metalwork, pipe, and other metal parts to be paid for by weight will be determined by the Engineer on the basis of handbook weights, scale weights, or manufacturer's catalog weights, or in the absence of any of the foregoing, on the basis of estimated weights; provided, that weights of nonmetallic coatings will be excluded.

7.01B Payment at Contract Prices - The contract price for an item of the work shall include full compensation for all costs of that item, including the costs of any work, materials and equipment incidental to the item but not specifically shown or described in the drawings and specifications, subject only to such express limitations as may be stated in the specifications defining the item or prescribing payment therefor.

The contract prices shall include full compensation for all costs of any work, materials, and equipment required by the drawings and specifications at the time of contract award, but not covered by a contract price or otherwise expressly made the subject of direct payment.

7.02 PAYMENT AND COMPENSATION FOR ALTERED QUANTITIES

When alterations in plans or quantities of work are ordered and performed, the Contractor shall accept payment in full at the contract unit price for the actual quantities of work done and no allowance will be made for anticipated profits. Increased or decreased work involving supplemental agreements will be paid for as stipulated in such agreements.

7.03 FORCE ACCOUNT PAYMENT

When extra work is to be paid for on a force account basis, compensation will be determined as follows:

7.03A Work Performed by Contractor - The Contractor will be paid for labor, materials, and equipment rental as hereinafter provided, except where agreement has been reached to pay in accordance with Section 7.03B. Only materials incorporated in the work will be paid for.

To the total computed as provided in Sections 7.03A(1), 7.03A(2) and 7.03A(3) will be added the following percentages:

Labor	-	24%
Materials	-	15%
Equipment Rental	-	15%

It is understood labor, materials, and equipment may be furnished by the Contractor or by the subcontractor or by others on behalf of the Contractor.

When extra work paid for on a force account basis is performed by forces other than the Contractor's organization, the Contractor shall reach agreement with such other forces as to the distribution of the payment made by the District for such work and no additional payment therefor will be made by the District.

7.03A(1) Labor - The Contractor will be paid the cost of labor for the workmen used in the actual and direct performance of the work. The cost of labor, whether the employer is the Contractor, subcontractor, or other forces, will be the sum of the following:

7.03A(1a) Actual Wages - The actual wages paid will be as published by the Director of Industrial Relations of the State of California for the region where work is performed and that are in effect at the time of award of the contract. The classification of workmen used shall not be in excess of the industry standard for the region where work is performed. Copies of the published labor rates are on file at the District office.

7.03A(1b) Labor Surcharge - To the actual wages as defined in Section 7.03A(1a), will be added a labor surcharge set forth in the Special Provisions, which labor surcharge shall constitute full compensation for all payments imposed by State and Federal laws and for all other payments made to, or on behalf of, the workmen, other than actual wages as defined in Section 7.03A(1a) and subsistence and travel allowance as specified in Section 7.03A(1c).

7.03A(1c) Subsistence and travel allowance paid to such workmen as required by collective bargaining agreements.

7.03A(2) Materials - The cost of materials incorporated in the work will be the cost to the purchaser, whether Contractor, subcontractor or other forces, from the supplier thereof, except as the following are applicable:

7.03A(2a) If a cash or trade discount by the actual supplier is offered or available to the purchaser, it shall be credited to the District notwithstanding the fact that such discount may not have been taken.

7.03A(2b) If the materials are procured by the purchaser by any method which is not a direct purchase from and a direct billing by the actual supplier to such purchaser, the cost of such materials shall be deemed to be the price paid to the actual supplier as determined by the Engineer. No markup except for actual costs incurred in the handling of such materials will be permitted.

7.03A(2c) If the materials are obtained from a supply or source owned wholly or in part by the purchaser, payment therefor will not exceed the price paid by the purchaser for similar materials furnished from said source on contract items or on the current wholesale price for such materials delivered to the job site whichever price is lower.

7.03A(2d) If the cost of such materials is, in the opinion of the Engineer, excessive, then the cost of such materials shall be deemed to be the lowest current wholesale price at which such materials are available in the quantities concerned delivered to the job site, less any discounts as provided in Section 7.03A(2a).

7.03A(2e) If the Contractor does not furnish satisfactory evidence of the cost of such materials from the actual supplier thereof, the cost shall then be determined in accordance with Section 7.03A(2d).

The District reserves the right to furnish such materials as it deems advisable, and the Contractor shall have no claims for costs and profit on such materials.

7.03A(3) Equipment Rates - The Contractor will be paid for the use of equipment at the rental rates listed for such equipment in the Special Provisions, regardless of ownership and any rental or other agreement, if such may exist, for the use of such equipment entered into by the Contractor. If it is deemed necessary by the Engineer to use equipment not listed in the Special Provisions, a suitable rental rate for such equipment will be established by the Engineer. The Contractor may furnish any cost data which might assist the Engineer in the establishment of such rental rate.

The rental rates paid as above provided shall include the cost of fuel, oil, lubrication, supplies, necessary attachments, repairs and maintenance of any kind, depreciation, storage, insurance, and all incidentals.

Operators will be paid for as provided under Section 7.03A(1).

All equipment shall, in the opinion of the Engineer, be in good working condition and suitable for the purpose for which the equipment is to be used.

Unless otherwise specified, manufacturer's ratings and manufacturer approved modifications shall be used to classify equipment for the determination of applicable rental rates. Equipment which has no direct power unit shall be powered by a unit of at least the minimum rating recommended by the manufacturer.

Individual pieces of equipment or tools having a replacement value of \$25.00 or less, whether or not consumed by use, shall be considered to be small tools and no payment will be made therefor.

Rental time will not be allowed while equipment is inoperative due to breakdowns.

In computing the rental time of equipment, less than 30 minutes shall be considered ½ hour.

7.03A(3a) Equipment on the Work - The rental time to be paid for equipment on the work shall be the time the equipment is in operation on the extra work being performed, and in addition, shall include the time required to move the equipment to location of the extra work and return it to the original location or to another location requiring no more time than that required to return it to its original location, except that moving time will not be paid for if the equipment is used at the site of the extra work on other than such extra work. Loading and transporting costs will be allowed, in lieu of moving time, when the equipment is moved by means other than its own power, except that no payment will be made if the equipment is used at the site of the extra work on other than such extra work.

7.03A(3b) Equipment not on the Work - For the use of equipment moved in on the work and used exclusively for extra work paid for on a force account basis, the Contractor will be paid the rental rates listed in the Special Provisions or as agreed to as provided in Section 7.03A(3) and for the cost of transporting the equipment to the location of the work and its return to its original location, all in accordance with the following provisions:

(1) The original location of the equipment to be hauled to the location of the work shall be agreed to by the Engineer in advance.

(2) The District will pay the costs of loading and unloading such equipment.

(3) The cost of transporting equipment on low bed trailers shall not exceed the hourly rates charged by established haulers.

(4) The cost of transporting equipment shall not exceed the applicable minimum established rates of the Public Utilities Commission.

(5) The rental period shall begin at the time the equipment is unloaded at the site of the extra work, shall include each day that the equipment is at the site of the extra work, excluding Saturdays, Sundays, and legal holidays unless the extra work is performed on such days, and shall terminate at the end of the day on which the Engineer directs the Contractor to discontinue the use of such equipment. The rental time to be paid per day will be in accordance with the following:

<u>Hours Equipment is in Operation</u>	<u>Hours to be Paid</u>
0.....	4
0.5.....	4.25
1.....	4.5
1.5.....	4.75
2.....	5
2.5.....	5.25
3.....	5.5
3.5.....	5.75
4.....	6
4.5.....	6.25
5.....	6.5
5.5.....	6.75
6.....	7
6.5.....	7.25
7.....	7.5
7.5.....	7.75
8.....	8
Over 8.....	hours in operation

When hourly rates are listed, less than 30 minutes of operation shall be considered to be 1/2 hour of operation.

When daily rates are listed, payment for 1/2 day will be made if the equipment is not used. If the equipment is used, payment will be made for one day.

The minimum rental time to be paid for the entire rental period on an hourly basis shall not be less than 8 hours or if on a daily basis shall not be less than one day.

(6) Should the Contractor desire the return of the equipment to a location other than its original location, the District will pay the cost of transportation in accordance with the above provisions, provided such payment shall not exceed the cost of moving the equipment to the work.

(7) Payment for transporting, loading and unloading equipment, as above provided, will not be made if the equipment is used on the work in any other way than upon extra work paid for on a force account basis.

7.03B Work Performed by Special Forces or Other Special Services - When the Engineer and the Contractor, by agreement, determine that a special service or an item of extra work cannot be performed by the forces of the Contractor or those of any of his subcontractors, such service or extra work item may be performed by a specialist. Invoices for such service or item of extra work on the basis of the current market price thereof may be accepted without complete itemization of labor, material, and equipment rental costs when it is impracticable and not in accordance with the established practice of the special service industry to provide such

complete itemization. In those instances wherein a Contractor is required to perform extra work necessitating a fabrication or machining process in a fabrication or machine shop facility away from the job site, the charges for that portion of the extra work performed in such facility may, by agreement, be accepted as a specialist billing.

To the specialist invoice price, less a credit to the District for any cash or trade discount offered or available, whether or not such discount may have been taken, will be added 15% in lieu of the percentages provided in Section 7.03A.

7.03C Records - The Contractor shall maintain his records in such a manner as to provide a clear distinction between the direct costs of extra work paid for on a force account basis and the costs of other operations.

The Contractor shall furnish the Engineer report sheets in duplicate of each day's extra work paid for on a force account basis no later than the working day following the performance of said work. The daily report sheets shall itemize the materials used, and shall cover the direct cost of labor and the charges for equipment rental, whether furnished by the Contractor, subcontractor, or other forces, except for charges described in Section 7.03B. The daily report sheets shall provide names or identifications and classifications of workmen, the hourly rate of pay and hours worked, and also the size, type and identification number of equipment, and hours operated.

Material charges shall be substantiated by valid copies of vendor's invoices. Such invoices shall be submitted with the daily report sheets, or if not available, they shall be submitted with subsequent daily report sheets. Should said vendor's invoices not be submitted within 15 days after acceptance of the work, the District reserves the right to establish the cost of such materials at the lowest current wholesale prices at which said materials are available in the quantities concerned delivered to the location of the work, less any discounts provided in Section 7.03A(2a).

Said daily report sheets shall be signed by the Contractor or his authorized agent.

The Engineer will compare his records with the daily report sheets furnished by the Contractor, make any necessary adjustments, and compile the costs of work paid for on a force account basis on daily extra work report forms furnished by the District. When these daily extra work reports are agreed upon and signed by both parties, they shall become the basis of payment for the work performed, but shall not preclude subsequent adjustment based on a later audit.

The Contractor's cost records pertaining to work paid for on a force account basis shall be open to inspection or audit by representatives of the District, during the life of the contract and for a period of not less than 18 months after the date of acceptance thereof, and the Contractor shall retain such records for that period. Where payment for materials or labor is based on the cost thereof to forces other than the Contractor, the Contractor expressly guarantees that the cost records of such other forces shall be open to inspection and audit by representatives of the District on the same terms and conditions as the cost records of the Contractor. If an audit is to be commenced more than 60 days after the acceptance date of the contract, the Contractor will be given a reasonable notice of the time when such audit is to begin.

7.03D Payment as provided above in Sections 7.03A and 7.03B shall constitute full compensation to the Contractor for performance of work paid for on a force account basis and no additional compensation will be allowed therefor.

7.04 ACCEPTANCE

The work shall be inspected for acceptance by the Engineer promptly upon receipt of notice in writing from the Contractor that the work is ready for such inspection.

The structures will not be finally accepted until the completion of the entire work under the contract.

7.05 DEDUCTIONS FROM PAYMENTS

The Riverside County Flood Control and Water Conservation District, by and through the Board of Supervisors or other appropriate District officer or officers, may at its option and at any time retain out of any amounts due the Contractor sums sufficient to cover any unpaid claims, provided that sworn statements of said claims shall have been filed in the office of the District or in the office of any other District officer or officers having jurisdiction thereover.

7.06 PARTIAL PAYMENTS

On or about the last day of each month, the Engineer shall make an estimate in writing of the total amount of work done by the Contractor to the time of such estimate and the value thereof. The District shall retain 5% of such estimated value of the work done as part security for the fulfillment of the contract by the Contractor. At no time shall the amount retained by the District be less than 5% of the total value of the work completed at the time such payments are made.

After deducting all previous payments and all sums to be kept or retained under the provisions of the contract, the District shall make monthly progress payments to the Contractor. No such estimate or payment shall be required to be made when, in the judgment of the Chief Engineer, the work is not proceeding in accordance with the provisions of the contract.

In accordance with Public Contract Code Section 22300 and other applicable law, the Contractor may substitute securities for any monies withheld to ensure performance under the contract. Such substitution shall be made only upon a separate agreement between the District and the Contractor which contains terms and conditions in compliance with all laws applicable to monies withheld under the contract.

7.07 DELAYED PAYMENTS

All the monies due the Contractor under the contract will be paid by demand on the Treasurer of the District, prepared and approved as required by law, and it is understood that any delay in the preparation, approval and payment of these demands will not constitute a breach of contract on the part of the District.

7.08 FINAL PAYMENT

The Engineer, after the completion of the contract, shall make a final estimate in writing to the Board of Supervisors of the amount of work done thereunder, and the value of such work, and the District shall pay the entire sum so found to be due after deducting therefrom all previous payments and all amounts to be kept and all amounts to be retained under the provisions of the contract. All prior partial estimates and payment shall be subject to correction in the final estimate and payment. The final payment shall not be due and payable until the expiration of 45 days from the date of acceptance of the work by the Board of Supervisors.

It is mutually agreed between the parties to the contract that no certificate given or payments made under the contract, except the final payment, shall be conclusive evidence of the performance of the contract, either wholly or in part against any claim of the party of the first part, and no payment shall be construed to be an acceptance of any defective work or improper materials.

And the Contractor further agrees that the payment of the final amount due under the contract, and the adjustment and payment for any work done in accordance with any alterations of the same, shall release the Riverside County Flood Control and Water Conservation District, the Board of Supervisors, and the Engineer from any and all claims or liability on account of work performed under the contract or any alteration thereof.

7.09 CLAIMS RESOLUTION - CLAIMS UP TO \$375,000

In accordance with Public Contract Code Section 20104 - 20104.8 and other applicable law, public works claims of \$375,000 or less which arise between the Contractor and the District shall be resolved following the statutory procedure.

1. All claims shall be submitted in writing and accompanied by substantiating documentation. Claims must be filed on or before processing of the final payment unless other notice requirements are provided in the contract. "Claim" means a separate demand by the claimant for (1) a time extension, (2) payment of money or damages arising from work done by or on behalf of the claimant and payment of which is not otherwise expressly provided for or the claimant is not otherwise entitled, or (3) an amount the payment of which is disputed by the District.

(a) Claims under \$50,000. The District shall respond in writing to the claim within 45 days of receipt of the claim, or, the District may request, in writing, within 30 days of receipt of the claim, any additional documentation supporting the claim or relating to defenses or claims the District may have against the claimant. If additional information is needed thereafter, it shall be requested and provided upon mutual agreement of the District and the claimant. The District's written response shall be submitted 15 days after receiving the additional documentation, or within the same period of time taken by the claimant to produce the additional information, whichever is greater.

(b) Claims over \$50,000 but less than or equal to \$375,000. The District shall respond in writing within 60 days of receipt, or, may request in writing within 30 days of receipt of the claim, any additional documents supporting the claim or relating to defenses or claims the

District may have against the claimant. If additional information is needed thereafter, it shall be requested and provided pursuant to mutual agreement between the District and the claimant. The District's response shall be submitted within 30 days after receipt of the further documents, or within the same period of time taken by the claimant to produce the additional information or documents, whichever is greater.

2. If the claimant disputes the District's response, or if the District fails to respond within the statutory time period, the claimant may so notify the District within 15 days of the receipt of the District's response or within 15 days of the District's failure to respond within the time prescribed, and demand an informal conference to meet and confer for settlement of the issues in dispute. Upon such demand, the District shall schedule a meet and confer conference within 30 days for settlement of the dispute.

3. If following the meet and confer conference, the claim or any portion thereof remains in dispute, the claimant may file a claim pursuant to Government Code § 900 et seq. and Government Code § 910 et seq. For purposes of those provisions, the time within which a claim must be filed shall be tolled from the time the claimant submits the written claim until the time the claim is denied as a result of the meet and confer process, including any time utilized for the meet and confer conference.

4. If a civil action is filed to resolve any claim, the provisions of Public Contract Code § 20104.4 shall be followed, providing for nonbinding mediation and judicial arbitration.

5. Location for Filing of Claims, Jurisdiction. Any legal action related to the performance of the work or the terms of the Contract Documents shall be filed only in the Superior Court of the State of California located in Riverside, California.

7.10 CLAIMS RESOLUTION - ALL CLAIMS (PUBLIC CONTRACT CODE SECTION 9204)

This section is intended to help resolve disputes between the parties related to this project. Such disputes shall be brought to the attention of the District at the earliest possible time, so that such disputes may be promptly resolved, if possible, or other appropriate action or investigation may be promptly undertaken. Claims must be filed on or before the date of final payment as required in Public Contract Code Section 20104.2. Public works claims which arise between the Contractor and the District shall be resolved using the following procedure:

A "claim" means a separate demand by the Contractor sent by registered mail or certified mail return receipt requested for one or more of the following: (a) a time extension including, without limitation, for relief from damages or penalties for delay assessed by the District; (b) payment by the District of money or damages arising from work done by or on behalf of the Contractor and payment for which is not otherwise expressly provided or to which the Contractor is not otherwise entitled; (c) payment of an amount that is disputed by the District. The Contractor shall furnish reasonable documentation to support the claim.

A. Form and Contents of Claim(s)

The Contractor shall furnish reasonable documentation to support the Claim, which shall be sent by registered mail or certified mail with return receipt requested to the District at the address provided herein this Section 7.10. The Contractor's written Claim must include, but not limited to, the following:

- 1) A statement to identify that it is a Claim under this Section 7.10, on a company letterhead, and a request for a decision on the Claim;
- 2) A detailed description or narrative of pertinent events, act, error, omission, unforeseen condition, event or other circumstance giving rise to the Claim;
- 3) Citation to contract provisions;
- 4) Theory of entitlement that provides a detailed justification for any remedy or relief sought by the Claim. This includes, but not limited to: a detailed cost breakdown, invoices, material tickets, staff logged time, summary of quantities, other cost records and total cost calculations;
- 5) Complete pricing of all cost impacts;
- 6) A time impact analysis of all time delays that shows actual time impact on the critical path; and
- 7) Documentation, District letters, notifications, related drawings and photos supporting items (1) through (6).

The Claim must be verified under penalty of perjury by Contractor's project superintendent as to the Claim's accuracy, and shall be priced like a Change Order, and must be updated at regular intervals as to cost and entitlement if a continuing Claim. Routine contract materials, for example, correspondence, RFI, Change Order requests, or payment requests shall not constitute a Claim. Contractor shall bear all costs incurred in the preparation and submission of a Claim.

Claims and support documentation related must be sent to:

Mr. Claudio M. Padres
Chief of Design and Construction Division
Riverside County Flood Control
and Water Conservation District
1995 Market Street
Riverside, CA 92501

B. Claims Procedure

- 1) Upon receipt of a Claim and the supporting documentation, the District shall conduct a reasonable review of the Claim and within 45 days, or an extended period as may be set by mutual agreement of the District and Contractor, provide the Contractor with a written statement identifying what portion of the Claim is still disputed and what portion is undisputed.
- 2) Notwithstanding the time period set forth in B.1) above, if the District needs approval from the Board of Supervisors to provide the Contractor with a

written statement identifying the disputed portion and the undisputed portion of the Claim, and the Board of Supervisors does not meet within the 45 days or within the mutually agreed to extension of time following receipt of the Claim, the District shall have up to three (3) days following the next duly publicly noticed meeting of the Board of Supervisors after the forty-five (45) day period, or extension, expires to provide Contractor a written statement identifying the disputed portion and the undisputed portion of the Claim.

- 3) Any payment due on the undisputed portion of the Claim under this section shall be processed and made within 60 days after the District issues its written statement. Amounts not paid in a timely manner as required by this Section 7.10 shall bear interest at 7% per annum. If the District fails to issue a written statement, the Claim shall be deemed rejected in its entirety. Failure by the District to respond to a claim from a Contractor within the time periods described in this subdivision or to otherwise meet the time requirements of this section shall result in the claim being deemed rejected in its entirety. A Claim that is denied by reason of the District's failure to have responded to the Claim, or its failure to otherwise meet the time requirements of this section, shall not constitute an adverse finding with regard to the merits of the Claim or the responsibility or qualifications of the Contractor.
- 4) If the Contractor disputes the District's written response, or if the District fails to respond within the time prescribed, the Contractor may demand in writing, sent by registered mail or certified mail return receipt requested, an informal meet and confer conference for settlement of the portion of the Claim in dispute. Upon receipt of the demand, the District shall schedule a meet and confer conference within 30 days.
- 5) Within 10 business days following the conclusion of the meet and confer conference, if the Claim or any portion thereof remains in dispute, the District shall provide the Contractor a written statement identifying the portion of the Claim that remains in dispute and the portion that is undisputed. Any payment due on an undisputed portion shall be processed and made within 60 days after the District issues its written statement. Any disputed portion of the Claim, as identified by the Contractor in writing, shall be submitted to nonbinding mediation, with the District and Contractor sharing the associated costs equally. The District and Contractor shall mutually agree to a mediator within 10 business days after the disputed portion of the Claim has been identified in writing. If the parties cannot agree upon a mediator, each party shall select a mediator and those mediators shall select a qualified neutral third party to mediate with regard to the disputed portion of the Claim. Each party shall bear the fees and costs charged by its respective mediator in connection with the selection of the neutral mediator.

- 6) For purposes of this section, mediation includes any nonbinding process, including but not limited to, neutral evaluation or a dispute review board, in which an independent third party or board assists the parties in dispute with resolution through negotiation or by issuance of an evaluation. Any mediation utilized shall conform to the timeframes in this section. Unless otherwise agreed to by the District and the Contractor in writing, the mediation conducted pursuant to this Section 7.10 shall excuse any further obligation under Section 20104.4 of the Public Contract Code to mediate after litigation has been commenced.
- 7) If mediation is unsuccessful to resolve all issues, the parts of the Claim remaining in dispute shall be subject to applicable procedures outside of this section and the requirements of Public Contract Code § 9204. The Claim resolution procedures in this Section do not preclude the District from requiring arbitration of disputes under private arbitration or the Public Works Contract Arbitration Program, if mediation under this Article does not resolve the parties' dispute.
- 8) Following the procedures set forth in this Section 7.10, including the mediation, if the Claim or any portion of it remains in dispute, the Contractor may file a Claim as provided in Chapter 1 (commencing with § 900) and Chapter 2 (commencing with § 910) of Part 3 of Division 3.6 of Title 1 of the Government Code.
- 9) If the Government Code claim is denied, Contractor may file an action in court. If a civil action is filed to resolve any claim, such action shall be subject to the provisions of Public Contract Code Sections 9204 or 20104.4 and shall be followed, providing for non-binding mediation and judicial arbitration. This Section applies only to claims subject to Public Contract Code Sections 9204 or 20104. If a claim is not subject to Public Contract Code Sections 9204 or 20104, the Contractor's right to file a civil action shall be as otherwise provided by law.

C. Subcontractor Claim(s)

If a subcontractor or a lower tier subcontractor has a Claim, the Contractor may present to the District a Claim on behalf of a subcontractor or lower tier subcontractor. A subcontractor may request in writing, either on his or her own behalf or on behalf of a lower tier subcontractor, that the Contractor present a Claim for work which was performed by the subcontractor or by a lower tier subcontractor on behalf of the subcontractor. The subcontractor requesting that the Claim be presented to the District shall furnish reasonable documentation as set forth in Section 7.10 to support the Claim. Within 45 days of receipt of this written request, the Contractor shall notify the subcontractor in writing as to whether the Contractor presented the Claim to the District, and if the Contractor did not present the Claim, provide the subcontractor with a statement of the reasons for not having done so.

D. Consistency with Public Contract Code Sections 9204 and 20104

If any Claim(s) arising under this Contract is subject to the provisions of Public Contract Code Sections 9204 or 20104 et seq. (Div. 2, Part 3, Chapter 1, Article 1.5), and if provisions of those statutory sections require a procedure or procedural element different from that established in this Contract, then the provisions of those statutory sections shall apply in place of the conflicting procedure or procedural element established herein.

E. Any legal action related to the performance of the work or the terms of the Contract Documents shall be filed only in the Superior Court of the State of California located in Riverside, California.

SECTION VIII - GENERAL

8.01 COOPERATION BETWEEN CONTRACTORS

The Contractor shall be required to cooperate fully with all utility and public agency representatives engaged in construction, relocation, altering or otherwise rearranging any facilities interfering with the progress of the work.

Full compensation for any delay or inconvenience to the Contractor's operation due to such operations as described above shall be considered included in the unit price paid for other items of work and no additional allowance will be made therefor.

8.02 INSURANCE - INDEMNIFICATION/HOLD HARMLESS/DEFEND

1. Insurance.

Contractor shall not commence work under this contract until he has obtained the insurance required hereunder and satisfactory proof of said insurance has been submitted to District and has been approved as to form by Riverside County Counsel.

Without limiting or diminishing the Contractor's obligation to indemnify, defend or hold the District harmless, Contractor shall procure and maintain or cause to be maintained, at its sole cost and expense, the following insurance coverages during the term of this Contract. In respects to the requirements for the Project and as further described in this section, the District herein refers to the Riverside County Flood Control and Water Conservation District, the County of Riverside, its Agencies, Districts, Special Districts and Departments, and any municipal corporation or governmental entity in which the work is to be accomplished, their respective directors, officers, Board of Supervisors, governing boards or councils, employees, elected and appointed officials, agents, representatives as Additional Insured.

Workers' Compensation - If the Contractor has employees as defined by the State of California, the Contractor shall maintain statutory Workers' Compensation Insurance (Coverage A) as prescribed by the laws of the State of California. Policy shall include Employers' Liability (Coverage B) including Occupational Disease with limits not less than **\$1,000,000** per person per accident. The policy shall be endorsed to waive subrogation in favor of the District and County of Riverside.

Commercial General Liability - Commercial General Liability insurance coverage, including but not limited to, premises liability, contractual liability, products and completed operations liability, personal and advertising injury, cross liability coverage, and covering claims which may arise from or out of Contractor's performance of its obligations hereunder. Policy shall name the District, all Agencies, Districts, Special Districts, and Departments of the County of Riverside, together with their respective directors, officers, Board of Supervisors, employees, elected or appointed officials, agents or representatives as Additional Insureds. Policy's limit of liability shall not be less than **\$2,000,000** per occurrence combined single limit. If such insurance contains a general aggregate limit, it shall apply separately to this agreement or be no less than two (2) times the occurrence limit.

Vehicle Liability - If Contractor's vehicles or mobile equipment are used in the performance of the obligations under this Agreement, then Contractor shall maintain liability insurance for all owned, non-owned or hired vehicles so used in an amount not less than **\$1,000,000** per occurrence combined single limit. If such insurance contains a general aggregate limit, it shall apply separately to this agreement or be no less than two (2) times the occurrence limit. Policy shall name the District, all Agencies, Districts, Special Districts, and Departments of the County of Riverside, together with their respective directors, officers, Board of Supervisors, employees, elected or appointed officials, agents or representatives as Additional Insureds.

Builder's Risk - Contractor shall obtain, at Contractor's expense, and keep in effect until final acceptance by the District, Builder's Risk Insurance (including earthquake and flood) covering the real and personal property of others in the care, custody, and control of the Contractor. Builder's Risk Insurance shall include theft and damage coverage. The minimum amount of coverage to be carried shall be equal to the full amount of the contract. Contractor shall be financially responsible for any deductible applied to loss. This insurance shall include the District, County of Riverside, the Contractor and its subcontractors as their interests may appear.

Professional Liability - Contractor shall maintain Professional Liability Insurance providing coverage for the Contractor's performance of work included within this Agreement, with a limit of liability of not less than \$2,000,000 per occurrence and \$4,000,000 annual aggregate. If Contractor's Professional Liability Insurance is written on a claims made basis rather than an occurrence basis, such insurance shall continue through the term of this Agreement and Contractor shall purchase at his sole expense either 1) an Extended Reporting Endorsement (also, known as Tail Coverage); or 2) Prior Dates Coverage from new insurer with a retroactive date back to the date of, or prior to, the inception of this Agreement; or 3) demonstrate through Certificates of Insurance that Contractor has Maintained continuous coverage with the same or original insurer. Coverage provided under items; 1), 2), or 3) will continue as long as the law allows.

Pollution and Asbestos Liability - If hazardous material is encountered during construction, the Project Manager must be notified immediately, and if any work is done to remove it, any Contractor performing work shall obtain and keep in effect during the term of their contract with Contractor, Pollution Liability Insurance, including Asbestos Liability Insurance, covering the subcontractor's liability for bodily injury, property damage, and environmental damage resulting from "sudden accidental" or "gradual" pollution and related cleanup costs incurred by the subcontractor, all arising out of the work or services (including the transportation risk, when applicable) to be performed under this contract. Combined single limit per occurrence shall not

be less than \$2,000,000, or the equivalent. Annual aggregate limit shall not be less than \$4,000,000.

If the Contractor maintains broader coverage and/or higher limits than the minimums shown above, the District requires and shall be entitled to the broader coverage and/or higher limits maintained by the Contractor. Any available insurance proceeds in excess of the specified minimum limits of insurance and coverage shall be available to the District.

General Insurance Provisions - All lines -

a) Any insurance carrier providing insurance coverage hereunder shall be admitted to the State of California and have an A.M. Best rating of not less than A: VIII (A:8) unless such requirements are waived, in writing, by the District Risk Manager. If the District's Risk Manager waives a requirement for a particular insurer such waiver is only valid for that specific insurer and only for one policy term.

b) The Contractor's insurance carrier(s) must declare its insurance deductibles or self-insured retentions. If such deductibles or self-insured retentions exceed \$500,000 per occurrence such deductibles and/or retentions shall have the prior written consent of the District's Risk Manager before the commencement of operations under this Agreement. Upon notification of deductibles or self-insured retentions unacceptable to the District, and at the election of the District's Risk Manager, Contractor's carriers shall either, 1) reduce or eliminate such deductibles or self-insured retentions as respects this Agreement with the District, or 2) procure a bond which guarantees payment of losses and related investigations, claims administration, and defense costs and expenses.

c) Contractor shall cause Contractor's insurance carrier(s) to furnish the District with either 1) a properly executed original Certificate(s) of Insurance and certified original copies of Endorsements effecting coverage as required herein, or 2) if requested to do so orally or in writing by the District's Risk Manager, provide original certified copies of policies including all Endorsements and all attachments thereto, showing such insurance is in full force and effect. Further, said Certificate(s) and policies of insurance shall contain the covenant of the insurance carrier(s) that 30 days written notice shall be given to the District prior to any material modification, cancellation, expiration or reduction in coverage of such insurance. In the event of a material modification, cancellation, expiration, or reduction in coverage, this Agreement shall terminate forthwith, unless the District receives, prior to such effective date, another properly executed original Certificate of Insurance and original copies of endorsements or certified original policies, including all endorsements and attachments thereto evidencing coverages set forth herein and the insurance required herein is in full force and effect. Contractor ***shall not commence operations until the District has been furnished original Certificate(s) of Insurance and certified original copies of endorsements or policies of insurance including all endorsements and any and all other attachments as required in this Section. An individual authorized by the insurance carrier to do so on its behalf shall sign the original endorsements for each policy and the Certificate of Insurance.***

d) It is understood and agreed to by the parties hereto and the insurance company(s), that the Certificate(s) of Insurance and policies shall so covenant and shall be construed as primary insurance, and the District's insurance and/or deductibles and/or self-insured retentions or self-insured programs shall not be construed as contributory.

e) The District's Reserved Rights--Insurance. If, during the term of this Agreement or any extension thereof, there is a material change in the scope of services; or, there

is a material change in the equipment to be used in the performance of the scope of work (such as the use of aircraft or watercraft), the District reserves the right to adjust the types of insurance required under this Agreement and the monetary limits of liability for the insurance coverages currently required herein, if, in the District's Risk Manager's reasonable judgment, the amount or type of insurance carried by the Contractor has become inadequate.

f) Contractor shall pass down the insurance obligations contained herein to all tiers of subcontractors working under this Agreement.

g) The insurance requirements contained in this Agreement may be met with a program(s) of self-insurance acceptable to the District.

h) Said insurance must contain an endorsement that District, County of Riverside, and any municipal corporation or governmental entity in which the work is to be accomplished, are named as an additional insured as respects the work covered hereunder. Said insurance must not contain, as respects the work covered hereunder, any exclusions as to bodily injury or death or property damage arising out of blasting, explosion, or underground damage to wire, pipes, conduits, mains, sewers, tank tunnels or any similar property, i.e., the so-called "x c u" exclusions. The insurance certificate evidencing such insurance must affirmatively state that the insurance carrier(s) will give District 30 days written notice prior to cancellation of the insurance or a reduction in coverage; must state that the "x c u" exclusions are waived or do not exist in the policy(s); and that District, County of Riverside, and any municipal corporation in which the work is to be accomplished, are named as an additional insured as respects the work covered hereunder.

The cost of this insurance shall be included in the prices bid for the various items of work and no additional compensation will be made therefor.

2. Indemnification - Hold Harmless and Defend.

Contractor shall indemnify and hold harmless the District, County of Riverside, and any municipal corporation or governmental entity in which the work is to be accomplished, together with its Agencies, Districts, Special Districts and Departments, their respective directors, officers, Board of Supervisors, elected and appointed officials, employees, agents and representatives (individually and collectively hereinafter referred to as Indemnitees) from any liability whatsoever, based or asserted upon any acts, omissions or services of Contractor, its officers, employees, subcontractors, agents or representatives arising out of or in any way relating to this Contract, relating to or in any way connected with or arising from the accomplishment of the work, whether or not in furtherance of the work, including but not limited to property damage, bodily injury, or death or any other element of any kind or nature whatsoever arising from the performance of Contractor, its officers, employees, subcontractors, agents or representatives Indemnitors from this Contract. Contractor shall defend, at its sole expense, all costs and fees including, but not limited, to attorney fees, cost of investigation, defense and settlements or awards, the Indemnitees in any claim or action based upon such alleged acts or omissions.

With respect to any action or claim subject to indemnification herein by Contractor, Contractor shall, at their sole cost, have the right to use counsel of their own choice and shall have the right to adjust, settle, or compromise any such action or claim without the prior consent of the District; provided, however, that any such adjustment, settlement or compromise in no manner whatsoever limits or circumscribes Contractor's indemnification to Indemnitees as set forth herein.

Contractor's obligation hereunder shall be satisfied when Contractor has provided to District the appropriate form of dismissal relieving the Indemnitees from any liability for the action or claim involved.

The specified insurance limits required in this Agreement shall in no way limit or circumscribe Contractor's obligations to indemnify and hold harmless the Indemnitees herein from third party claims.

In the event there is conflict between this clause and California Civil Code Section 2782, this clause shall be interpreted to comply with Civil Code 2782. Such interpretation shall not relieve the Contractor from indemnifying the Indemnitees to the fullest extent allowed by law.

3. Obligations.

The obligations assumed by Contractor cover all obligations set forth in this Subsection and elsewhere in the Contract Documents, such as Subsections 5.01, 5.02, 5.05, 5.06, 5.08, 5.09, 5.10, 10.01, and 10.02.

8.03 PUBLIC UTILITIES

The locations of all pipelines, power lines, communication lines and other utility components known to District to exist within the limits of the work, are indicated on the drawings and may be the subject of a specific Special Provision(s). Size, location and characteristics of such utilities is based upon information made available to District - primarily from the owner of the utility in question. The exactness of such information is not guaranteed but may be assumed to have been accomplished with reasonable accuracy.

In addition to the drawings and any such provision regarding utilities, Contractor is under a duty to take into account the location of service laterals or other appurtenances which can be inferred from the presence of facilities such as buildings, meters and junction boxes in or about the limits of the work.

Unless otherwise directed by the Contract Documents, all existing utilities - where shown or described or not - shall be left in place and Contractor must conduct its operations so that such utilities are protected from damage at all times during the course of the work and the work must be accomplished so as to give such utilities proper protection and support upon completion of the work by Contractor.

If during the course of the work, Contractor discovers underground utility components not indicated in the drawings, the Special Provisions or elsewhere in the Contract Documents, Contractor must immediately notify, in writing, the Engineer and the utility company (public or private) involved, stating with exactness the condition found.

When Contractor encounters a utility not shown or described in the Contract Documents, Contractor shall cease all work which would disturb such utility and its support until given specific instructions as to how to proceed regarding such utility by Engineer. All work done by Contractor to protect existing utilities shown or described in the Contract Documents, or which can be

reasonably inferred from the presence of other visible facilities, is at Contractor's expense, the cost of which is deemed included in Contractor's Proposal to do the work.

Contractor's cost of locating, repairing damage not due to the failure of Contractor to exercise reasonable care, and removing or relocating utility components and facilities not indicated in the drawings, specifications or elsewhere in the Contract Documents with reasonable accuracy, shall be paid Contractor as Extra Work as provided in Subsection 2.07 and Subsection 7.03 of these General Provisions. Compensation for idle time of equipment shall be paid as provided in Section 8-1.07C, "Payment Adjustments", of the State Standard Specifications. No surcharge rates for equipment will be applied for idled equipment.

District may direct the Contractor to do such repair or relocation work as required. When such repair or relocation work is not elsewhere provided for in these Contract Documents, or reasonably inferred therefrom, a requirement of District that Contractor perform such work shall be compensated for as Extra Work pursuant to Subsections 2.07 and 7.03 of these General Provisions.

Contractor shall not be assessed liquidated damages for delay in completion of the project, if such delay is caused by failure of District, or the owner of the utility in question, to provide for removal or relocation of the utility involved.

8.04 PROTECTION OF EXISTING STREET FACILITIES

The Contractor shall be responsible for the protection of existing signs, fences, concrete curbs, gutters and other facilities which may be encountered. The replacement or repair of any facilities which the District deems necessary as a result of the Contractor's operations shall be done by the Contractor at his own expense and to the satisfaction of the Engineer.

Excavation within the street right of way shall be conducted in a manner to cause the least interruption to traffic. Where traffic must cross open trenches, the Contractor shall provide suitable bridges at street intersections and driveways. Hydrants under pressure, valve pipe covers, valve boxes, curb stop boxes, fire or police call boxes, or other utility controls shall be left unobstructed and accessible during construction.

8.05 DIVERSION AND CONTROL OF WATER

Unless otherwise provided in the Proposal, no separate payment will be made for diversion and control of surface or groundwater. All costs incidental to maintaining dry working areas shall be included in the unit prices paid for other items of work in the schedule.

8.06 DUST ABATEMENT

During the performance of all work included in the contract, the Contractor shall take the necessary precautions to save the District free and harmless from any loss or damage resulting from his operations that raise or produce dust in such amounts that will be objectionable, and/or cause damage to adjacent property or property owners.

The Contractor will be required to have a positive and continuous method of dust control which is satisfactory to the Engineer. The methods to be used for controlling dust in the construction area and along haul roads shall be approved by the Engineer prior to starting any of the work included in the contract. All costs incidental to dust control shall be included in the unit prices paid for other items of work in the schedule.

8.07 PROJECT SIGNS

The Contractor shall erect project signs at the locations designated by the Engineer.

No separate payment will be made for erecting the project signs and all costs in connection therewith will be considered a subsidiary obligation of the Contractor.

8.08 EXAMINATION OF PLANS, SPECIFICATIONS, CONTRACT, AND SITE OF WORK

The bidder shall examine carefully the site of the work contemplated, the plans and specifications, and the proposal and contract forms therefor. The submission of a bid shall be conclusive evidence that the bidder has investigated and is satisfied as to the conditions to be encountered, as to the character, quality, and scope of work to be performed, the quantities of materials to be furnished, and as to the requirements of the proposal, plans, specifications, and the contract.

Where the District has made investigations of subsurface conditions in areas where work is to be performed under the contract, or in other areas, some of which may constitute possible local material sources, such investigations are made only for the purpose of study and design. Where such investigations have been made, bidders or Contractors may, upon request, inspect the records of the District as to such investigations subject to and upon the conditions hereinafter set forth. Such inspection of records may be made at the office of the District.

The records of such investigations are not a part of the contract and are shown solely for the convenience of the bidder or Contractor. It is expressly understood and agreed that the District assumes no responsibility whatsoever in respect to the sufficiency or accuracy of the investigations thus made, the records thereof, or of the interpretations set forth therein or made by the District in its use thereof and there is no warranty or guarantee, either expressed or implied, that the conditions indicated by such investigations or records thereof are representative of those existing throughout such areas, or any part thereof, or that unlooked-for developments may not occur, or that materials other than, or in proportions different from those indicated, may not be encountered.

When a log of test borings showing a record of the data obtained by the District's investigation or subsurface conditions is included with the contract plans, it is expressly understood and agreed that said log of test borings does not constitute a part of the contract, represents only the opinion of the District as to the character of the materials encountered by it in its test borings, is included in the plans only for the convenience of bidders and its use is subject to all of the conditions and limitations set forth in this Section 8.08.

No information derived from such inspection of records of investigations or compilation thereof made by the District or from the Engineer, or his assistants, will in any way relieve the bidder or Contractor from any risk or from properly fulfilling the terms of the contract.

SECTION IX - WATERING

9.01 DESCRIPTION

This work shall consist of developing a water supply for all water required for the work. The application of the water shall be under the control of the Engineer at all times and shall be applied in the amounts and at the locations approved by the Engineer.

At least one mobile unit of at least 1,000-gallon capacity for applying water shall be available on the project at all times.

Water for compacting embankment material and for laying dust shall be applied by means of pressure-type distributors or pipelines equipped with a spray system or hoses with nozzles that will ensure a uniform application of water.

No separate payment or additional allowances will be made for this work and all costs in connection therewith will be considered as included in other items in the schedule.

SECTION X - PUBLIC CONVENIENCE, TRAFFIC CONTROL AND DETOURS

10.01 GENERAL

The Contractor shall so conduct his operations as to offer the least possible obstruction and inconvenience to the public and he shall have under construction no greater length or amount of work than he can prosecute properly with due regard to the rights of the public.

Unless otherwise provided in the Special Provisions, all public traffic shall be permitted to pass through the work with as little inconvenience and delay as possible.

Spillage resulting from hauling operations along or across any public traveled way shall be removed immediately at the Contractor's expense.

Construction operations shall be conducted in such a manner as to cause as little inconvenience as possible to abutting property owners.

Convenient access to driveways, houses and buildings along the line of work shall be maintained and temporary approaches to crossings or intersecting highways shall be provided and kept in good condition.

10.02 SIGNS

It shall be the responsibility of the Contractor to provide and maintain all lights, barricades and signs, both on and off the site of work, as required by the Engineer, and all such devices shall be of a type approved by him.

If, in any case, the Engineer finds it necessary to replace, add to or erect said barricades, signs, or lights, when the Contractor fails to do so when informed, the Contractor shall be billed for all costs thereof including a daily rental fee for signs.

No separate payment, unless otherwise provided for under the Special Provisions, will be made for traffic control and detour signing and all costs incidental to these items shall be included in the unit prices paid for other items of work.

10.03 MATERIALS STORAGE

Storing or stockpiling of excavated material, imported backfill material or construction materials on any street or highway will not be permitted except as approved in writing by the Engineer.

SPECIAL PROVISIONS
AND
DETAILED SPECIFICATIONS

SPECIAL PROVISIONS

SECTION 1 - GENERAL

1.1 Drawings and Specifications - These documents are for the construction of Palm Canyon Wash, Stage 93 Emergency Levee Restoration, located in the city of Palm Springs, Riverside County, California. This work shall conform with the contract drawings indexed on the cover sheet of the drawings included herewith.

Referenced standard drawings are available on the District web site.

The Contractor shall copy any of the referenced District standard drawings from <http://www.rcflood.org>.

The Contractor shall be responsible to obtain referenced standard plans/drawings of various agencies from their respective office or web site.

References made in these Special Provisions or Detailed Specifications to the "Greenbook Specifications" refer to the "Greenbook" Standard Specifications for Public Works Construction, current edition, including supplements. Standard Specifications of the American Society for Testing and Materials shall be designated by ASTM and the appropriate number of the standard. Unless otherwise specified, wherever the words "Caltrans Specifications" are used in these Special Provisions or Detailed Specifications they shall mean the Standard Specifications of the State of California, Department of Transportation, 2018 edition. Whenever the words "Caltrans Standards" are used they shall mean the Standard Plans of the State of California, Department of Transportation, 2018 edition, unless otherwise noted.

In the event that discrepancies are encountered, the option that provides the method, item or material with the greatest strength or utility shall be chosen, as directed by the Engineer.

In case of conflict between the drawings and the specifications, the drawings shall govern; in case of conflict between the referenced specifications and these specifications, the latter shall govern.

1.2 Submittals to District - Submittals shall be sent in the form of email or postal carrier to the attention of the Engineer. The Contractor shall allow the Engineer five (5) working days from the time of receipt of the submittal (mailing time is not included) to review and respond in writing.

SECTION 2 - TIME OF COMPLETION, DAMAGES AND LEGAL HOLIDAYS

2.1 General - Following award of the contract, the Contractor shall comply with the following schedule:

STRICTLY ENFORCED SUBMITTALS TIMELINE POST AWARD

	Submittal	First Complete Submittal Deadline	District Review Timeline	Approval Deadline
Required Approvals for Unconditional Notice to Proceed (NTP)	Trench Safety System (Section 15)	Award date plus 10 working days	5 working days	Award date plus 20 working days
	Confined Space Procedures (Section 6.3)	Award date plus 10 working days	5 working days	
	OSHA Excavation Permit (Section 6.3)	Award date plus 10 working days	5 working days	
	Dust Control Plan (Section 27)	Award date plus 10 working days	5 working days	
	Stormwater Pollution Prevention Plan (Section 29.3)	Award date plus 10 working days	5 working days	
	City Business License (Section 6.5)	Award date plus 10 working days	5 working days	
	Material Submittals	All other project material submittals, including concrete, steel, etc.	15 working days before ordering of materials	

The Contractor shall begin work within ten (10) calendar days after the date of receipt of Notice to Proceed from the Engineer and shall diligently prosecute the same to completion before the expiration of

ONE HUNDRED FORTY (140) WORKING DAYS

from the date of the project's first working day identified in the Notice to Proceed and as defined in Section 2.2.

In addition to the working day requirement provided above, construction activities shall only be conducted between July 1, 2020 and March 31, 2021 to avoid conflict with the endangered species known as the Casey's June beetle. Any construction activities within the project working limits outside of that date range is strictly prohibited.

2.2 Notice to Proceed - A Notice to Proceed will be issued, and the project working days shall begin no later than 20 working days after project award. The Contractor's attention is directed to Section 2.1 above. The Notice to Proceed will be issued unconditionally if all submittals are complete and accepted by the approval deadline dates listed in Section 2.1 table above. If the required submittals are not complete and accepted, the Notice to Proceed will be conditioned accordingly, and construction can start only for the items with accepted submittals. Work shall not start on items lacking acceptable submittals. The District will not extend the

project working days due to the Contractor's failure to secure acceptable submittals for all the items in the timeframes required in Section 2.1.

2.3 Damages - The Contractor and the District expressly agree that the cost to the District for inspection and superintendence of the work for this contract is \$1,600.00 per working day.

2.4 Legal Holidays - The Contractor will not be permitted to work on Legal Holidays (Reference Sections 6.02 and 6.06 of the General Provisions), except in cases of emergency as directed by the Engineer.

SECTION 3 - FORCE ACCOUNT PAYMENT

3.1 Labor Surcharge - Attention is directed to the provisions of Section VII, Article 7.03A(1b) of the General Provisions. The labor surcharge percentage to be applied to the actual wages paid as defined in Paragraph 7.03A(1a) will be twenty-four percent (24%).

3.2 Equipment Rental - Attention is directed to the provisions of Section VII, Article 7.03A(3) of the General Provisions. The equipment rental rates to be applied will be the rates published by the California Department of Transportation and in effect at the time of the award of the contract. A copy of said Equipment Rental Rates is on file at the District Office.

SECTION 4 - PROTECTION OF EXISTING UTILITIES

4.1 General - All existing underground utility lines, power poles and overhead wiring shall be protected in place at all times, except as noted otherwise on the plans. Any damage to utilities caused by the Contractor's operation shall be repaired or replaced at the Contractor's expense.

Prior to the commencement of any construction activities, the Contractor shall contact all utility companies and local municipalities servicing the project area to review as-built utility drawings and determine appropriate means of protecting utilities.

At the discretion of the Engineer, the Contractor may be required to verify, by potholing, the location of potentially affected utilities.

4.2 Cooperation with Utilities Relocated by Others or Protected in Place - Some utilities will require relocation by others prior to or during construction or be protected in place as shown on the drawings and as specified in these specifications and Special Provisions.

Supplement to Section 8.01 of the General Provisions. The Contractor shall coordinate and cooperate with the various utilities or their contractors to ensure the work proceeds in an orderly manner.

The Contractor shall stage his work as required to accommodate the following utility construction or relocations or to protect them in place:

- (a) The following overhead powerlines are to be protected in place during construction:

Existing overhead powerlines and communication lines at approximately Stations 106+20 and 102+40 on Sheet 6.

- (b) The following existing waterlines are to be protected in place during construction:

Existing 12" waterline at approximately Station 85+38 on Sheet 4.

Should any utility relocation result in delays to the Contractor's work schedule, the Contractor shall be entitled only to an equivalent extension of time for the completion of the contract, and shall not be entitled to damages due to downtime and idled equipment or additional payment over and above the agreed upon contract unit prices.

SECTION 5 - PROJECT SITE MAINTENANCE

Through all phases of construction, the Contractor shall comply with the provisions of Section 3-12 of the Greenbook Specifications. Before final acceptance of the work, the Contractor shall clean the work and the site of the work of all falsework, temporary structures, other construction materials and equipment, excess materials and rubbish, and shall leave the work and the site in a neat and presentable condition. Such final cleanup work shall be performed within the time specified for completion of all of the work.

SECTION 6 - SPECIAL REQUIREMENTS

6.1 National Pollutant Discharge Elimination System (NPDES) - The Contractor shall comply with the requirements of Board Order No. R7-2013-0011 (NPDES No. CAS617002), NPDES Municipal Stormwater Permit, hereafter referred to in this Section as the "Permit", issued by the California Regional Water Quality Control Board (CRWQCB) – Colorado River Basin Region. This Permit regulates stormwater discharges associated with construction activities performed under the direction of a municipal stormwater permittee. The Contractor shall prepare and implement a Pollution Prevention Plan (PPP) in accordance with Section 29 "Stormwater and Non-Stormwater Pollution Control" of the Detailed Specifications.

The Contractor's attention is directed to: 1) Section 29.2 "General Requirements" which allows the Engineer to withhold progress payments if the Contractor fails to fully implement Section 29 "Stormwater and Non-Stormwater Pollution Control" or is deemed to be in non-compliance with the provisions of the Permit; 2) Section 29.3 "Pollution Prevention Plan Preparation and Approval" which requires that a PPP be prepared and approved prior to the Pre-Construction meeting; and 3) Section 29.5 "Pollution Prevention Plan Implementation" which allows the Engineer to suspend construction operations if the Contractor fails to implement the approved PPP and any amendments thereto.

6.2 Sanitation - Sewage flows shall not be interrupted. Should the Contractor disrupt existing sewer facilities, sewage shall be conveyed in closed conduits and disposed of in a sanitary sewer

system. If pumping is required it shall be done at the expense of the Contractor. A backup pumping system with equal capacity shall be provided at all times. Sewage shall not be permitted to flow in trenches or be covered by backfill.

6.3 Confined Space Compliance - The Contractor shall comply with all Cal/OSHA safety regulations including regulations concerning confined space and for maintaining a safe working environment for Contractor and District employees on the site.

If excavations that meet the thresholds defined by Cal/OSHA will be implemented for the work, the Contractor shall develop and maintain a confined space procedure specific to this contract that complies with the requirements contained in California Code of Regulations, Title 8, Section 5158, Other Confined Space Operations and the District Confined Space Procedure, SOM-18. A copy of SOM-18 can be obtained from the District office, 1995 Market Street, Riverside upon request.

Within five (5) days after the award of the contract, the Contractor shall submit three (3) copies of the procedure to the Engineer for review and approval. The Contractor shall allow the number of working days specified in Section 1.2 of these Special Provisions for the Engineer to review the procedure. If revisions are required as determined by the Engineer, the Contractor shall revise and resubmit the procedure within three (3) working days of receipt of the Engineer's comments and shall allow four (4) working days for the Engineer to review the revisions. The Contractor must submit three (3) copies of the approved procedure to the Engineer prior to the pre-construction meeting.

The procedure shall provide for recording of data to develop a history of acceptable atmosphere within the confined space. That history will include:

1. Calibration schedule of a direct reading confined space meter by trained personnel.
2. Daily monitoring and recording of the confined space atmosphere with a calibrated direct reading confined space meter.
3. Records of Items 1 and 2 shall be maintained onsite and copies given to the Engineer.
4. The records shall indicate if readings are of natural or mechanically enhanced ventilation.

In addition, the procedure shall include daily tours of the job site with the Engineer to ensure inlets to the confined space are free of obstruction or substances that might affect the atmosphere of the confined space.

The Contractor will be required to keep a direct reading confined space meter onsite for the duration of the contract. The meter shall be calibrated according to the schedule specified in

the Contractor's confined space procedure and shall be made available for the Engineer's use upon request.

6.4 Heavy Equipment Working Hours - Heavy construction equipment shall be allowed to work from 7:00 a.m. to 3:30 p.m. each normal working day, unless otherwise approved by the Engineer. Any extension of the work hours described above will be limited to daylight hours. The Engineer will not approve night work, and no work will be allowed on weekends unless approved otherwise by the Engineer.

All points of ingress and egress shall be kept clean of sediment and debris at all times. Contractor shall retain street sweeping equipment onsite at all times during operations to ensure public rights of way are clean and free of dirt, dust, and debris. All public streets within 500 feet of ingress and egress points shall, at a minimum, be swept twice per day during all operations.

6.5 Business License - The Contractor is required to obtain a business license from the City of Palm Springs for work within the city limits. The City of Palm Springs will require the Contractor to pay a fee for the business license. A copy of the business license shall be provided to the Engineer prior to commencement of work.

6.6 Toxic Material Disposal - Toxic materials including oil, fuel oil, gasoline, coolant, fluid filters and other contaminants shall not be discharged within the project site. All such materials shall be transported offsite and disposed of at a County approved facility.

6.7 Survey Crew - The Contractor shall notify the Engineer in writing at least 48 hours prior to new construction staking and shall provide safe and unobstructed access to the staking area within this period. Should the staking area be inadequately prepared, unsafe, or obstructed when the District's Survey Crew arrives onsite to perform the new construction staking, the Contractor shall be subject to delay charges as defined below.

Survey Crews will be available Monday through Thursday from 7:00 a.m. to 3:30 p.m., with a half-hour off for lunch. If the Contractor requires the Survey Crew to work beyond the specified time mentioned above, it shall be considered as overtime and shall be paid by the Contractor at 1.5 times the Survey Crew's hourly rates.

The Contractor shall carefully preserve benchmarks, reference points, and stakes. In case of willful or careless destruction, the Contractor shall be charged with the resulting expense and shall be responsible for any mistakes that may be caused by their unnecessary loss or disturbance.

If the District's Survey Crew incurs delays or survey restaking is required as a result of the Contractor's operations, the Contractor shall be charged at a rate of \$250 per hour, with a minimum charge of two (2) hours for each restaking request. Payment shall be deducted from the monthly progress payment.

6.8 Survey Monuments - The Contractor shall salvage and give to the District all survey monuments and wells removed during construction. The District will reset monuments after construction.

6.9 Job Trailer Site - The Contractor is required to provide a site and install an office trailer for District personnel. This trailer shall be in good condition and located in a place acceptable to the District. The trailer shall be for the sole use of the District and shall not be used by the Contractor for any activity, including storage. The Contractor shall make provisions for the privacy and security of the office, and provide air conditioning, drinking water, electrical service, and a private portable toilet for the Inspector. The Contractor shall also provide two office chairs and a desk suitable for reviewing plans. The Contractor shall pay the monthly billings for these services. The trailer shall be fully operational and available to District personnel on the first day of work. Should the trailer or office not be available and in working condition, it is agreed by both parties at the time of entering this contract that damages in the amount of \$3,000 per month shall be assessed. It is agreed that this amount may be prorated and shall be deducted from the first contract payment and any successive payments covering any period that the facilities are unavailable.

6.10 Construction Tolerances - Variation in alignment, grade and dimensions of the structures and structural components from the established alignment, grade and dimensions shown on the drawings shall be within the tolerances specified in the following:

Table A – Tolerances for Grading Unlined Channels, Levees and Access Roads		
Departure from established alignment		2 inches on tangents 4 inches on curves
Departure from established profile grade	Channel bottoms, channel sideslopes in cut and fill, levee and access road sideslopes in cut	Zero <u>above</u> and 3 inches <u>below</u> the specified grade
	Top surfaces of levees and access roads in both cut and fill, levee and access road sideslopes in fill	Zero <u>below</u> and 3 inches <u>above</u> the specified grade

Regardless of the construction tolerances specified, the excavation and grading shall be performed so that the finished surfaces are in uniform planes with no abrupt breaks in the surface.

Table B - Tolerances for Trapezoidal Concrete Lined Channels and Levees		
Departure from established alignment		2 inches on tangents 4 inches on curves
Departure from established profile grade		1 inch
Variation in thickness of lining, sideslopes and invert		5 percent of specified thickness provided average thickness is maintained
Variation from specified width of section at any height		0.0025 times specified width W plus 1 inch. 0.0025W + 1 inch

Variation from specified height of lining		0.005 times specified height H plus 1 inch. 0.005H + 1 inch
Variation in surfaces (gradual)	Invert Sideslopes	¼ inch in 10 feet ½ inch in 10 feet
Variation in surfaces (abrupt)		¼ inch

Gradual Variation tolerance shall be measured by placing a 10-foot straightedge anywhere on the finished concrete structure within 72 hours after concrete placement. The gap at any point between the straightedge and the concrete shall not exceed the specified amount.

Departure from established alignment		1 inch on tangents 2 inches on curves
Departure from established profile grade		1 inch
Inside dimensions		0.005 times specified dimension
Variation from the plumb or the specified batter in the lines and surfaces of walls, piers and in arises	Exposed, in 10 feet Backfilled, in 10 feet	½ inch 1 inch
Variation in cross-sectional dimensions		Minus ¼ inch Plus ½ inch
Variation in surfaces (gradual)	Invert Soffits, Walls, Sideslopes	¼ inch in 10 feet ½ inch in 10 feet
Variation in surfaces (abrupt)		¼ inch

Variance from indicated position	Spacing between adjacent bars and the distance between layers of bars	one bar diameter nor more than one inch
Concrete cover measured perpendicular to steel in the direction of tolerance		¼ inch

Elements not meeting these requirements shall be removed and replaced as directed by the Engineer.

6.11 Surplus Excavated Material - Any stockpiling, grading or disposal of material outside of the project limits is not covered under the District's permits and is the sole responsibility of the Contractor. Related regulatory permits that may be required include, but are not limited to, Federal Clean Water Act (Sections 401 and 404), California Fish and Game Code (Section 1602) and Federal/State Endangered Species Acts. All costs to obtain any regulatory permits related to stockpiling, grading, or disposal of material outside of the project limits shall be borne by the Contractor.

6.12 Project Sign - Supplementing Section 8.07 of the General Provisions, the Contractor shall be required to provide one new project sign. The Contractor shall install and maintain the project sign at location specified by the Engineer, with painting and lettering as shown in Appendix "B" of these Special Provisions. The sign shall be installed as directed by the Engineer within five (5) days after District issuance of the Notice to Proceed. Upon completion of construction, the sign shall be removed.

6.13 Liability Insurance - The Contractor's attention is directed to Section 8.02, Insurance - Indemnification/Hold Harmless/Defend, of the General Provisions. The City of Palm Springs shall also be named as additional insureds with the liability insurance coverage required to be maintained by the Contractor.

6.14 Fish and Game Code Section 1610 Emergency Work Compliance - Pursuant to Fish and Game Code Section 1610 Emergency Work Compliance notification provided by the District to California Department of Fish and Wildlife, State of California, the Contractor shall comply with the requirements set forth in this notification, particularly the following:

- 1) The person(s) completing the emergency work should prevent raw cement, concrete, or washings thereof, asphalt, paint, or other coating material, oil or other petroleum products, or any other substance which can be deleterious to aquatic life from contaminating soil and/or entering a river, stream, lake, or other waters of the state (see Fish and Game Code Section 5650).
- 2) The person(s) completing the emergency work should minimize the disturbance or removal of vegetation in completing the work.

6.15 404 Permit Compliance - Pursuant to Section 404 of the Clean Water Act, a verification letter and email was issued by the Army Corps of Engineers authorizing the emergency work under Regional General Permit (RGP) 63.

The Contractor shall comply with the requirements of RGP 63 and the Casey's June Beetle Conservation Measures below:

1. As much as feasible, avoid removal or damage to tree and shrub vegetation, with particular emphasis on larger, mature trees/shrubs such as desert willow and smoke tree.
2. Trees that cannot be avoided will be salvaged and buried within the excavation area during the backfill operation.

This verification letter and email are included as Appendix "D" of these specifications.

6.16 401 Certification Compliance - Pursuant to the Clean Water Act Section 401, a Water Quality Certification (WQC) and Order for RGP 63 was issued by the State Water Resources Control Board. The Contractor shall comply with the requirements set forth in this WQC and Order particularly the following:

1. At all times, appropriate types and sufficient quantities of materials shall be maintained onsite to contain and clean up any spill or inadvertent release of materials that may cause a condition of pollution or nuisance if the materials reach waters of the state. Construction personnel must know how to use appropriate containment and cleanup materials.
2. Fueling, lubrication, maintenance, storage, and staging of vehicles and equipment must not result in a discharge to any waters of the state and shall be located outside of waters of the state in areas where accidental spills will not enter or affect such waters.
3. If construction related materials reach surface waters, appropriate spill response procedures must be initiated as soon as the incident is discovered. In addition, the State Water Board staff contact identified in the Order must be notified via email and telephone within twenty-four (24) hours of occurrence.
4. Construction materials and debris from all construction work areas shall be removed from the site and disposed of properly following completion of the project.
5. Water diversion activities must not result in the degradation of beneficial uses or exceedances of water quality objectives of any of the receiving waters. Any temporary dam or other constructed obstruction must only be built from materials which will cause little or no siltation (e.g., clean gravel). Normal flows must be restored to the affected water immediately upon completion of work at that location.
6. Effective best management practices (BMPs) must be implemented to control erosion and runoff from areas associated with the emergency project; this includes access roads. All areas of temporary impacts and all other areas of temporary disturbance which could result in a discharge or a threatened discharge to waters of the U.S. and/or state must be restored. Restoration must include grading of disturbed areas to pre-project contours.
7. All repairs and reconstruction shall be kept to the minimum necessary to alleviate the immediate emergency and limited to in-kind replacement or refurbishment of onsite features. Minor upgrading may be considered if the Enrollee uses bioremediation or other environmentally sensitive solutions. Permanent restoration work other than that performed as an associated part of the emergency operations, including any minor upgrades, shall not be performed without prior approval and authorization by the Water Boards.

This WQC is included as Appendix "E" of these specifications.

6.17 Coordination with Tribal Monitoring - A monitor from the Agua Caliente Band of Cahuilla Indians may be onsite during the levee repair. The Contractor shall coordinate and cooperate with the District's Inspector and Tribal representative.

If potential findings are uncovered during excavation activity, the Contractor's attention is directed to Section 6.18 Accidental Discovery.

6.18 Accidental Discovery - In the event that any human remains, hazardous materials, historical, tribal, archaeological, or paleontological resources are accidentally discovered within project limits, the Contractor shall immediately cease all construction or ground disturbance activity in the vicinity of find and notify the Engineer. District will provide the appropriate professional to assess the significance of the discovery and, if necessary, develop appropriate management and treatment measures. **The Contractor shall not resume construction in the affected area without Engineer's approval.**

Per State Health and Safety Code 7050.5, if human remains are encountered during construction, no further disturbance shall occur within the vicinity of the find until the Riverside County Coroner has made a determination of origin and disposition pursuant to Public Resources Code Section 5097.98. The Riverside County Coroner must be notified within 24 hours by the Engineer. If the County Coroner determines that the remains are not historic, but prehistoric, the Native American Heritage Commission (NAHC) must be contacted by the Engineer to determine the most likely descendent for this area. Once the most likely descendent is determined, treatment of the Native American human remains will proceed pursuant to Public Resources 5097.98. The NAHC may become involved with decisions concerning the disposition of the remains.

Should any of the above mentioned discoveries result in delays to the Contractor's work schedule, the Contractor shall be entitled only to an equivalent extension of time for the completion of the contract, and shall not be entitled to damages due to downtime and idle equipment or additional payments over and above the agreed upon contract prices.

6.19 Nesting Bird Pre-Construction Survey - The removal of potential nesting vegetation should be conducted outside of the nesting season to avoid impacts to active bird nests if practicable. The nesting season is defined as December 15th through September 15th. If construction activities occur during the nesting season, including vegetation removal, a nesting bird survey of potentially suitable nesting vegetation will be conducted by the District prior to construction. Surveys will be conducted no more than three (3) days prior to construction. If active nests are identified, the District will establish a 50- to 500-foot buffer around the vegetation containing the active nest as recommended by a biologist. The vegetation containing the active nest will not be removed, and no grading will occur within the established buffer, until it has been determined that the nest is no longer active (i.e., the juveniles are surviving independent from the nest). If construction activities are not conducted within three (3) days of a negative survey, the nesting survey must be repeated to confirm the absence of nesting birds.

Should nesting birds result in delays to the Contractor's work schedule, the Contractor shall be entitled only to an equivalent extension of time for the completion of the contract, and shall not be entitled to damages due to downtime and idle equipment or additional payments over and above the agreed upon prices.

6.20 Coordination with Regulatory and Environmental Permitting Staff - The Contractor shall allow personnel with the various agencies to access the site to inspect, monitor, and conduct various field measurements as deemed necessary.

6.21 Installation of Roadway Lighting or Permanent Light Sources - Due to potential impacts to the endangered species known as the Casey's June beetle, the Contractor is prohibited from installing any and all road lighting or generating new permanent light sources within the project area.

6.22 Coordination with Biological Monitor - The District's Biological Monitor will be monitoring the levee repair activities as directed by the District. The Contractor shall coordinate and cooperate with the Biological Monitor during all construction related activities.

6.23 Coordination with Smoke Tree Stables - The Contractor shall coordinate and accommodate the needs, to the extent feasible, of the existing horse stable known as Smoke Tree Stables located at 2500 South Toledo Avenue, Palm Springs, CA 92264. The District and Contractor shall meet with a stable representative prior to the commencement of work in order to determine what specific accommodations are needed when working in close proximity to the stables (e.g., no parking of vehicles or equipment will be allowed near the levee access gate, work is to be temporarily suspended when horse tours are in close proximity, no work shall be permitted during the weekend), and the City of Palm Springs working hour ordinances shall be observed to ensure the continued function of the business.

6.24 Pedestrian Access - The Contractor shall enforce no pedestrian access to the levee construction area from existing ingress and egress points. The Contractor shall post adequate signage to prohibit any form of pedestrian access within the work area to the satisfaction of the Engineer. All such signage must remain in place at all times, including when the site is not in active construction.

SECTION 7 - SOILS REPORT

In conjunction with the soils investigation/geotechnical report prepared by BTC Labs - Vertical Five also known as NV5 dated May 5, 2014, the Contractor's attention is directed to Article 8.08 of the General Provisions. The relevant logs of the soil borings for this report are included for the convenience of the bidders, in conformance with Section 8.08 of the General Provisions, as Appendix "C" of these specifications. The soils report is on file in the District office, 1995 Market Street, Riverside and the relevant information is available for review upon request.

SECTION 8 - NOT USED

SECTION 9 - PAYMENT

The contract prices shall include full compensation for all costs incurred under these Special Provisions and Detailed Specifications.

DETAILED SPECIFICATIONS

SECTION 10 - MOBILIZATION

10.1 Description - The contract item Mobilization shall consist of expenditures for all preparatory work and operations, including but not limited to, those costs necessary for the movement of personnel, equipment, supplies and incidentals to the project site; for the establishment of all offices, buildings, construction yards and other facilities necessary for work on the project; and for all other work and operations which must be performed or costs incurred prior to beginning work on the various contract items on the project site as well as the related demobilization costs anticipated at the completion of the project.

10.2 Payment - The amount credited for Mobilization on each monthly progress payment shall be equal to the total of the amounts credited for work on all the other contract items for that monthly progress payment, up to a cumulative limit of eighty percent (80%) of the lump sum price bid for Mobilization. The remaining twenty percent (20%) of the lump sum price bid for Mobilization will be paid with the final payment.

Payment of the lump sum contract price for Mobilization shall constitute full compensation for all labor, materials, equipment, and all other items necessary and incidental to completion of this item of work.

The deletion of work or the addition of extra work as provided for herein shall not affect the price paid for Mobilization.

SECTION 11 - WATER CONTROL

11.1 Description - This section covers the contract item Water Control. Watersheds and/or urban runoff areas are tributary to the project site at various locations, but do not necessarily follow the alignment of the project under current conditions. Surface water and flow within the existing wash, in varying quantities, can be expected at any time of the year, and substantial runoff can be expected during periods of rainfall. Groundwater was not indicated at the time of the soils investigation for this project. All bidders shall make their own determination regarding what the surface and/or groundwater conditions will be at the time of construction, and their impact on the bidder's operations and construction phasing.

11.2 Water Control - The contract item Water Control includes the control and/or diversion of surface runoff as well as all sources of water flowing within the existing wash and within the work area as required to complete the work. The Contractor's attention is directed to the existing connection at approximate levee Station 85+38 where water discharge occurs frequently by the Desert Water Agency during dry weather. All work shall be carried on in areas free of water. Care should be exercised so that runoff or diversion flows do not erode, undermine, or otherwise damage or degrade the condition of the work site, constructed facilities, adjacent private properties, or alter the suitability of the site for proposed work. The responsibility for the protection of all existing and proposed improvements lies with the Contractor.

11.3 Measurement and Payment - The methods of controlling both surface and groundwater will be the responsibility of the Contractor. The contract lump sum price paid for Water Control shall include full compensation for all direct and indirect costs incurred under this section, and for doing all the work involved in controlling surface runoff and groundwater within the construction area, as specified in these Detailed Specifications, and as directed by the Engineer.

Payment will be made on a basis of the percentage of the work completed on the entire project.

SECTION 12 - NOT USED

SECTION 13 - CLEARING AND MISCELLANEOUS WORK

13.1 Description - This section covers the contract item Clearing and Miscellaneous Work as required for construction of the work. All objectionable materials shall be removed and disposed of outside of the limits of the construction easements and permanent rights of way.

13.2 Clearing and Miscellaneous Work - The contract item Clearing and Miscellaneous Work includes the removal and legal disposal of all debris, waste material, vegetation, trees, roots, stumps, fences, pipes, rocks, existing structures, existing rock gabion mesh and steel members, and asphalt.

Included in this item are the following:

1. The Contractor shall preserve large native tree and shrub species (typically over 6 feet in height), where feasible, as indicated on the drawings and where determined in the field by District staff. The Contractor shall keep all stockpiling of excavated material outside of the drip line of any designated native tree or shrub species. If avoidance of designated trees/areas is not feasible during construction, the District Inspector shall be notified prior to any disturbance or removal.

Any tree or shrub species not identified for preservation shall be cut and stockpiled for later burial within the project limits. The Contractor shall mark the outside corners of burial site locations and notify the District Inspector who will have all burial sites surveyed following completion of backfill operations.

2. To avoid the potential transfer of invasive plant species into Palm Canyon Wash, the Contractor shall thoroughly wash all vehicles and equipment prior to entering Palm Canyon Wash to ensure the absence of dried mud. The Contractor shall also subsequently visually inspect and monitor all vehicles and equipment entering the wash to ensure they are clean and free from such dried mud.
3. The removal separation and disposal of existing rock gabion structures and the associated mesh and steel members within the project limits. Rock shall be stockpiled and placed as indicated on the drawings. All other removed materials shall be legally disposed offsite.

Finally, included in this item are those types of work as shown on the drawings not specified for pay under any other individual contract item.

13.3 Payment - The contract price paid for Clearing and Miscellaneous Work shall be full compensation for all costs incurred under this section.

This payment will be made on a basis of the percentage of work completed on the entire project.

SECTION 14 - EARTHWORK

14.1 Description - This section covers the contract items Excavation; Backfill; and Embankment.

14.2 General Excavation Requirements - Excavation shall be in conformance with Section 306 of the Greenbook Specifications. Trench access ladders shall be in conformance with Section 306-3.6 and the manner of shoring and bracing shall be in conformance with Section 306-4 of the Greenbook Specifications.

Excavation shall be kept to the minimum dimensions and widths required for efficient placing of the Class "A" Concrete, Slope Paving; Class "B" Concrete, 2' Cutoff Wall; and Class "B" Concrete, 4' Cutoff Wall. The maximum length of open trench shall be in conformance with Section 306-3.5 of the Greenbook Specifications, unless authorized otherwise by the Engineer.

In excavating for surfaces against which concrete is to be placed, care shall be exercised in removing the final lift. The foundation for all concrete structures including Class "A" Concrete for paving and footing; and Class "B" Concrete for cutoff walls will be inspected and tested after excavation. The subgrade shall be ninety percent (95%) relative compaction prior to the placement of concrete. Surfaces against which concrete is to be placed shall be free of debris, mud or ponded water. If subgrade compaction is deficient, subgrade shall be scarified, moisture conditioned to or slightly above optimum moisture content, and the surface proof rolled to a minimum ninety percent (95%) relative compaction. Subgrade preparation will not be measured or paid separately and no additional compensation will be allowed unless overexcavation is directed by Engineer.

Material which will not provide a suitable foundation shall be removed and replaced with compacted select material as directed by the Engineer.

Any overexcavation shall be filled with select material compacted to ninety percent (95%) relative compaction and meeting the material requirements for Embankment.

The Contractor shall remove slides and materials eroding into the work, and the slopes and grades refinished to original grades as specified.

The removal of rock material from within the excavation paylines which requires the use of blasting or equipment beyond that normally necessary to accomplish the excavation (as determined by the Engineer) shall be paid for in accordance with Section VII, Article 7.03 of the General Provisions.

Blasting, when necessary, as approved by the Engineer shall be in accordance with Section 19-2.03E of the Caltrans Specifications.

The Contractor's attention is directed to the General Provisions, Section V, Article 5.09 on the use of explosives and Article 5.11 in regard to unforeseen difficulties.

14.3 Excavation - The contract item Excavation covers all costs associated with the excavation, overexcavation, and temporary stockpiling of excavated material necessary for the construction and installation of the concrete structures as shown on the project drawings, standard drawings, and as directed by the Engineer. Overexcavation shall be as directed by the Engineer and as shown on the drawings to ensure proper tie-in into the existing levee mass in a transverse and longitudinal direction. All existing concrete slope paneling shall be sawcut at the limits of removal unless otherwise specified. Removal of existing concrete slope paneling is covered under Section 21 of these Detailed Specifications.

14.4 General Backfill and Embankment Requirements - Whenever fill is specified or required or otherwise specified herein, the work shall be performed as set forth in Sections 300-4.1 to 300-4.2 and 300-4.4 to 300-4.8 of the Greenbook Specifications.

All soil fill material placed shall be moistened and shall be free of sod, roots, brush, debris, trash, and other objectionable material, as directed by the Engineer.

No backfill materials shall be placed against the outside walls of cast-in-place concrete structures until the concrete has developed eighty percent (80%) of its design strength. No fill will be permitted on the top of any cast-in-place concrete structure until the concrete in the structure has attained its design strength. Compressive strength will be determined by test cylinders taken by the Engineer. A maximum of six (6) test cylinders per structure will be made and paid by the District for the following day breaks: 7, 14, 21, 28, two additional cylinder breaks at 28 days to report the average as required by ACI certification, and one break to be agreed upon by the Engineer and Contractor. Any additional test cylinders requested by Contractor shall be deducted from the monthly progress payment at a rate of \$500.00/cylinder.

Regardless of the method of densification, backfill material shall not be placed against any reinforced concrete structure until the structure has been inspected and approved for backfilling by the Engineer.

Backfill will be accomplished by either mechanical methods as described below.

Mechanical Compaction - Backfill shall be mechanically compacted by means of tamping rollers or other mechanical tampers. Impact-type pavement breakers (stompers) will not be permitted unless otherwise approved by the Engineer.

All backfill material for structures shall be placed in uniform layers and shall be brought up uniformly on each side of the structure. The thickness of each layer of backfill shall not exceed 8 inches before compaction unless otherwise approved by the Engineer. For hand directed mechanical compactors, the thickness of each layer shall not exceed 4 inches before compaction.

All relative compaction tests will be made by the Engineer in conformance with ASTM D1557. Whenever relative compaction is specified to be determined by ASTM D1557.

Approval to use specific methods and compaction equipment shall not be construed as guaranteeing or implying that the use of such methods and equipment will not result in damage to adjacent ground, existing improvements or improvements installed under the contract, nor shall it be construed as guaranteeing proper compaction. The Contractor shall make his own determination in this regard.

All backfill above Class "A" Concrete, Slope Paving shall be compacted to not less than existing pre-construction conditions as determined by District staff. District staff will perform compaction testing on existing soils within the project limits to determine compaction requirements. The Contractor must endeavor to meet existing pre-construction compaction conditions due to the sensitivity of endangered species. Final compaction of all backfill shall be tested and approved by the Engineer.

14.5 Testing - District personnel shall perform compaction tests as described below using either the ASTM D1556 (sand cone) or ASTM D6938 (nuclear) test method. These tests represent the minimum required. Additional tests may be taken at the Engineer's discretion. Any failed test will result in a retest.

14.6 Backfill - The contract item Backfill covers all costs associated with hauling material from the stockpile, and placement and compaction of such material as shown on the project drawings, standard drawings, and as directed by the Engineer. Excluded from this item is any embankment fill used to establish the subgrade necessary for the construction of Class "A" Concrete, Slope Paving; Class "B" Concrete, 2' Cutoff Wall; and Class "B" Concrete, 4' Cutoff Wall.

14.7 Embankment - The contract item Embankment covers all associated with hauling material from the stockpile, placement of such material, and constructing compacted levee embankment for the construction of Class "A" Concrete, Slope Paving as shown on the project drawings, and as directed by the Engineer.

No embankment material shall be placed in any section of the levee until the foundation for that section has been examined, tested, and approved by the Engineer.

The embankment material shall be obtained from required Excavation, as directed by the Engineer.

The embankment material shall be free of sod, roots, brush, debris, trash, rocks over 6 inches in largest diameter, and other objectionable material. Clods or hard lumps over 6 inches in greatest dimension shall be broken up before compacting in embankments. All embankments and fills shall be constructed of approved material selected from required excavations as directed by the Engineer.

Material shall be placed in horizontal layers not more than 8 inches in thickness before compaction. If any oversized rock is encountered, it shall be removed from the embankment before compacting.

Material placed in the embankment shall be disked, harrowed or manipulated by other approved methods so as to obtain the best possible mixture and gradation, and shall be free from lenses, pockets, or streaks of material differing substantially in texture and gradation from the surrounding material.

Prior to and during the compaction operations, the material in each layer of the embankment shall, if necessary, be moistened and manipulated to attain moisture content within the range as determined by the Engineer. The moisture content shall be uniform throughout the layer. The moisture content of the soils at the time of compaction shall fall within the range from optimum moisture, to three percent (3%) above optimum.

Embankment material which contains excessive moisture shall not be compacted until the material is sufficiently dry to comply with the specified moisture content. No separate payment will be made for any additional work involved in drying embankment material to the required moisture content.

To obtain the specified moisture content, the Contractor will be required to perform such operations as are considered necessary by the Engineer. Application of water to the material for this purpose shall be done at the site of excavation as far in advance of excavation operations as possible to ensure uniformity of moisture content. Supplementary water, as required, shall be added to each layer and to the foundation by sprinkling the soil and by disking, harrowing, or otherwise manipulating the soil during and after the time the water is added. No layer of fill shall be compacted before the specified moisture content has been obtained.

The embankment compaction shall be done with a tamping roller, rubber-tired roller or other approved compaction equipment moving parallel to the axis of the levee and be compacted to not less than ninety-five percent (95%) relative compaction when measured in conformance with California Test Method 216. The method of compaction shall be subject to the approval of the Engineer.

It may be feasible to transport a portion of the materials which are excavated for other parts of the work, and which are suitable for embankment construction, directly to the embankment at the time of making the excavations, however, the Contractor shall be entitled to no additional compensation, above the unit prices named in the Contract Schedule for excavation and embankment, by reason of it being necessary or required by the Engineer, that such

excavation materials be deposited in temporary storage piles prior to being placed in the embankments or other mandatory fill areas.

14.8 Measurement - Excavation; Backfill; and Embankment beyond the limits established by the project drawings, unless ordered in writing by the Engineer, will not be measured for payment.

Measurement for payment for the contract item Excavation will be the number of cubic yards and shall be measured from the ground surface existing at the start of excavation to the established competent and approved subgrade as determined from surveyed cross sections provided by District Surveyors. Exclusive of the Excavation contract item are the 2' and 4' cutoff wall excavation and footing excavation for all Class "A" Concrete, Slope Paving panels.

Measurement for payment for the contract items Backfill; and Embankment will be the number of cubic yards of fill material placed in final position as specified and shown on the project drawings, or as directed by the Engineer. Measurement will be from the established competent and approved subgrade to the finished grades as determined from surveyed cross sections provided by District Surveyors.

14.9 Payment - The contract prices paid for Excavation; Backfill; and Embankment shall include full compensation for all costs incurred under this section.

SECTION 15 - TRENCH SAFETY SYSTEM

15.1 Description - This section covers the contract item Trench Safety System. This item is defined as a method of protecting employees from cave-ins, from material that could fall or roll from an excavation face or into an excavation, or from the collapse of adjacent structures. Trench safety systems include support systems, sloping and benching systems, shield systems and other systems that will provide necessary protection. The item includes the furnishing and implementation of the safety system as required by Section 306-4 of the Greenbook Specifications or as directed by the Engineer.

15.2 Trench Safety System - Excavation for any trench five (5) feet or more in depth shall not begin until the Contractor has provided to the Engineer, a detailed plan for worker protection from the hazards of caving ground during the excavation of the trench. The plan shall show the details of the design of shoring, bracing, sloping or other provisions to be made for worker protection including any design calculations done in the preparation of the plan. No such plan shall allow the use of shoring, sloping or a protective system less effective than that required by the Construction Safety Orders of the California Department of Industrial Relations, Division of Occupational Safety and Health Administration (Cal-OSHA). The plan shall be prepared and signed by an engineer who is registered as a Civil Engineer in the State of California, and the plan and design calculations shall be submitted for review at least two (2) weeks before the Contractor intends to begin trenching operations.

All safety plans shall reflect surcharge loadings imparted to the side of the trench by equipment and stored materials. Surcharge loads shall be monitored to verify that such loads do not exceed the design assumptions for the system.

The Contractor should not assume that only one type of trench safety system such as a shield or "trench box" will be adequate for all trenching situations encountered on a given project. The Contractor should be prepared with alternative safety system designs (such as solid sheeting) should construction circumstances dictate the use of such.

Trench safety system designs for support systems, shield systems or other protective systems whether drawn from manufacturers' data, other tabulated data or designed for this particular project must be signed by a Civil Engineer registered in the State of California prior to submittal to the District for review. A shoring plan for the specific use of a shield shall be prepared. Catalogs or engineering data for a product should be identified in the plan as supporting data. All specific items or applicable conditions must be outlined on the submittal.

The State of California Department of Transportation "Trenching and Shoring Manual" will be used as a guide for plan review and approval.

Also included in this item is the fencing and barricading of the open trench as required for safety as directed by the Engineer.

15.3 Measurement and Payment - The contract price paid for the item Trench Safety System shall include full compensation for all costs incurred under this section.

This payment will be made on a basis of the percentage of the work completed on the items related to trenching operations.

SECTION 16 - CONCRETE CONSTRUCTION

16.1 Description - This section includes the contract items related to the various classes of Concrete.

16.2 General Requirements - Concrete for all purposes shall be composed of Portland Cement, aggregates and water of the quantities and qualities herein specified, and in the required proportions. The ingredients are to be well mixed (a minimum of 70 drum revolutions, and a maximum of 250 drum revolutions are required to provide sufficient agitation to the concrete mix) and brought to the proper consistency and to have a compressive strength at the age of 28 days of not less than the amount shown in the following tabulation for each type of work listed:

<u>CONCRETE CLASS</u>	<u>MINIMUM SACKS CEMENT/C.Y.</u>	<u>TYPE OF WORK</u>	<u>POUNDS PER SQUARE INCH</u>
A	6	Slope Paving	3250
B	5	Cutoff Walls, and Miscellaneous Concrete not otherwise specified	3000

16.3 Material and Methods - All concrete materials, methods, forms and proportioning shall conform to Sections 51 and 90 of the Caltrans Specifications. Concrete test specimens will be made in accordance with ASTM Designation C-31 and C172. Test for concrete compressive strengths will be performed in accordance with ASTM Designation C-39. Combined aggregate grading for all concrete shall be in conformance with Section 90-1.02C(4)(d) of the Caltrans Specifications and the following tabulation for each type of work listed:

TYPE OF WORK	COMBINED AGGREGATE GRADING
Slope Paving, Cutoff Walls, and other Miscellaneous Concrete not otherwise specified. All other concrete structures.	1" Maximum

Fly Ash, Class F may be substituted for cement, up to a maximum of 15 percent by weight for all concrete. Fly Ash shall meet the standards of ASTM Designation: C-618. Water reducing agents meeting ASTM Designation: C-494 will be permitted in amounts recommended by the supplier and approved by the Engineer in writing.

No other admixture shall be used in any class of concrete without written permission from the Engineer.

Supplementing Section 90-1.01 of the Caltrans Specifications, prior to placement of any concrete the Contractor shall submit mix designs, for all types of concrete to be placed, to the Engineer for approval. Supplementing Section 90-1.02G(3) of the Caltrans Specifications, concrete delivered to the job site shall be accompanied by a ticket containing the weight of each of the individual ingredients in the mix.

16.4 General Reinforcing Steel Requirements - Reinforcing steel for all reinforced concrete structures shall be Grade 60 Low-Alloy or Grade 60 Billet-Steel. Cleaning, bending, placing and spacing of reinforcement shall conform to the applicable provisions of Section 52 of the Caltrans Specifications and to the drawings. The Contractor shall furnish a "Certificate of Compliance" with the specification of ASTM Designation: A-706/A or A-615/A. All splices shall conform to the requirements of A.C.I. Manual, Standard 318, latest edition. Splices requested by the Contractor for his convenience shall be subject to approval by the Engineer. Longitudinal lap shall be 16 inches minimum for #4 bars and 19 inches minimum for #5 bars.

16.5 Consistency - The consistency of the concrete shall be such as to allow it to be worked into place without segregation. Unless otherwise specified, the slump shall be 3 inches plus or minus 1 inch for all concrete.

The slump test shall be performed in accordance with the requirements of ASTM Designation: C-143. Slumps greater than those specified may be cause for rejection of the concrete by the Engineer.

16.6 Placing - Supplementing Section 51-1.03D(1) of the Caltrans Specifications, concrete shall not be placed except in the presence of the Engineer. The Contractor shall give reasonable notice to the Engineer each time he intends to place concrete. Such notice shall be far enough in advance to give the Engineer adequate time to inspect the subgrade, forms, steel reinforcement and other preparations for compliance with the specifications before concrete is delivered for placing.

Formed concrete shall be placed in horizontal layers in lifts of not more than 20 inches. Hoppers and chutes, pipes and "elephant trunks" shall be used as necessary to prevent segregation of the concrete.

16.7 Form Removal and Finish - Forms shall be removed only when the Engineer has given his approval. Forms shall be removed in such a way as to prevent damage to the concrete. Supports shall be removed in a manner that will permit the concrete to take stresses due to its own weight uniformly.

Forms shall not be removed sooner than the following minimum time or strength after the concrete is placed. These times represent cumulative number of days and fractions of days, not necessarily consecutive, during which the temperature of the air adjacent to the concrete is above 50 degrees Fahrenheit. If the temperature falls below 50 degrees Fahrenheit at any time after the concrete is placed in the forms, the Engineer will advise the Contractor of additional time required before forms can be removed.

Element	Strength or Time
Slope Paving and all other structures	16 hours

The finish on all exposed formed surfaces shall conform to Section 51-1.03F(3) Class 1 Surface Finish of the Caltrans Specifications. A tight wood float finish will be required on the surface of all channel slope paving and excessive surface working will not be permitted. The exposed concrete surfaces shall be broomed in a transverse direction with a fine textured hair push broom to produce a uniform surface and eliminate float marks. Brooming shall be done when the surface is sufficiently set to prevent deep scarring. If directed by the Engineer, a fine spray of water shall be applied to the surface immediately in advance of brooming.

Exposed corners of all concrete structures shall be finished with a 3/4" chamfer.

Concrete flatwork shall match adjacent surfaces. The concrete shall be struck off and tamped or vibrated until a layer of mortar has been brought to the surface. The top surface of slope paving shall be finished to match adjacent surfaces.

16.8 Curing - All concrete shall be prevented from drying for a curing period of at least seven (7) days after it is placed. Surfaces exposed to air during the curing process shall be kept continuously moist for the entire period or until curing compound is applied.

Formed surfaces shall be thoroughly wetted immediately after forms are removed and shall be kept wet until patching and repairs are completed. Water or covering shall be applied in such a way that the concrete surface is not eroded or otherwise damaged. Water for curing shall be clean and free from any substances that will cause discoloration of the concrete.

Concrete may be coated with curing compound in lieu of the continued application of moisture. The curing compound shall comply with the requirements of Section 90-1.03B(3) of the Caltrans Specifications and ASTM Designation C-309. The curing compound shall be No. 2 White Pigmented Curing Compound, Type 2, Class B for all concrete surfaces other than for flatwork which shall be coated with No. 6 Nonpigmented Curing Compound, Type 1-D, Class A containing a red fugitive dye.

The curing compound shall be sprayed on the moist concrete surfaces as soon as free water has disappeared, but shall not be applied to any surface until patching, repairs and finishing of that surface are completed. The curing compound shall be thoroughly mixed immediately before applying, and shall be applied at a uniform rate of not less than one gallon per 150 square feet of surface. No separate payment will be made for the curing compound or its application.

16.9 Joints - Joints shall be made at the locations shown on the project drawings, or as approved by the Engineer.

The Contractor shall construct, in one continuous concrete placing operation, all work comprised between such joints. Joints shall be kept moist until adjacent concrete is placed.

All construction joints having a keyed, stepped, or roughened surface shall be cleaned by sandblasting prior to placement of the adjacent concrete, unless otherwise directed by the Engineer.

The sandblasting operations shall be continued until all unsatisfactory concrete, laitance, coatings, stains, debris, and other foreign materials are removed. The surface of the concrete shall be washed thoroughly to remove all loose material.

Transverse weakened plane joints shall be required in slope paving at 10-foot spacing or as directed by the Engineer.

The Contractor may elect to form the weakened plane joints in the channel surface by cutting a groove in the surface with a power driven saw. The grooves shall be cut to a minimum depth of 0.17 foot and the width shall be the minimum width possible with the type of saw being used, but in no case shall the width exceed 0.02 foot. The weakened plane joints shall be sawed within 12 hours after the concrete has been placed.

Construction joints, when required, shall be located between the transverse joints and, unless otherwise specified on the plans, shall utilize 1/2 inch diameter deformed bars 30 inches long, spaced at 18-inch centers as tie bars. The construction joints shall be straight and finished in a workmanlike manner.

Surfaces of construction joints shall be cleaned as set forth in Section 51-1.03D(4) of the Caltrans Specifications.

16.10 Class "A" Concrete, Slope Paving - The contract item Class "A" Concrete, Slope Paving includes the concrete paving of the levee paneling and footing. Included in the pay item is all reinforcing steel required and the additional excavation for the levee paneling footing (2' wide by 1' deep), but exclusive of all other earthwork covered under Section 14.

Finish surface of the levee shall be true to line and grade and concrete shall be not less than the minimum thickness indicated on the drawings, and as specified in Section 6.10 Construction Tolerances of the Special Provisions.

16.11 Class "B" Concrete, 2' Cutoff Wall - The contract item Class "B" Concrete, 2' Cutoff Wall includes the complete construction of the entire longitudinal (continuous) cutoff walls on the levee slope paving and transverse cutoff walls, as shown on the project drawings. Included in the pay item is all earthwork and reinforcing steel.

16.12 Class "B" Concrete, 4' Cutoff Wall - The contract item Class "B" Concrete, 4' Cutoff Wall includes the complete construction of the entire transverse cutoff walls as shown on the project drawings. Included in the pay item is all earthwork and reinforcing steel.

16.13 Measurement - Measurement for payment for the contract item Class "A" Concrete, Slope Paving will be the number of cubic yards placed as specified, measured to the neat lines as shown on the project drawings.

Measurement for payment for the contract item Class "B" Concrete, 2' Cutoff Wall will be the number of lineal feet placed, measured parallel to the top of the wall slope or along the transverse edge of the levee paneling.

Measurement for payment for the contract item Class "B" Concrete, 4' Cutoff Wall will be the number of lineal feet placed, measured along the transverse edge of the levee paneling.

No measurement or payment will be made for dowels, tie bars, tie wires, blocks, chairs and other accessories.

16.14 Payment - The contract prices paid for the various Concrete items and reinforcing steel items shall include full compensation for all costs incurred under this section.

SECTION 17 THROUGH SECTION 19 - NOT USED

SECTION 20 - FENCES AND GATES

20.1 Description - This section covers the contract items Remove and Reinstall Fence; Remove and Reinstall Gate.

20.2 Remove and Reinstall Fence - The contract item Remove and Reinstall Fence covers all costs associated with removal and reinstallation of existing fencing used for levee access. The work shall be as directed by the Engineer and within existing District rights of way. Materials shall be salvaged and reinstalled subject to the Engineer's approval prior to reinstallation. Otherwise, if materials are damaged by the Contractor and are not approved by the Engineer for reinstallation, the salvaged material shall be legally disposed of offsite and replaced in kind with new materials at the Contractor's cost. In the event new materials are needed the new materials shall conform to District Standards Drawing No. M801.

20.3 Remove and Reinstall Gate - The contract item Remove and Reinstall Gate covers all costs associated with removal and reinstallation of existing gates used for levee access. The work shall be as directed by the Engineer and within existing District rights of way. Materials shall be salvaged and reinstalled subject to the Engineer's approval prior to reinstallation. Otherwise, if materials are damaged by the Contractor and are not approved by the Engineer for reinstallation, the salvaged material shall be legally disposed of offsite and replaced in kind with new materials at the Contractor's cost. In the event new materials are needed the new materials shall conform to District Standards Drawing No. M801.

20.4 Measurement - Measurement for payment for the contract item Remove and Reinstall Fence will be the number of lineal feet of fence installed measured along the top of the fence parallel to the ground.

Measurement for payment for the contract item Remove and Reinstall Gate will be for each pair of removed gates installed.

20.5 Payment - The contract price paid for Remove and Reinstall Fence; and Remove and Reinstall Gate shall include full compensation for all costs incurred under this section.

SECTION 21 - MISCELLANEOUS

21.1 Description - This section covers the contract items Existing Riprap Removal, Temporary Stockpiling and Final Placement; Air-Blasting; Existing 4" Unreinforced Concrete Slope Paneling Breaking and Removal, Temporary Stockpiling and Final Placement; Toe Extension Epoxy; Perimeter Demarcation Fencing; and Extra Directed Work.

21.2 Existing Riprap Removal, Temporary Stockpiling and Final Placement - The contract item Existing Riprap Removal, Temporary Stockpiling and Final Placement includes all costs associated with the removal of all existing levee riprap and rock within the excavation area, temporary stockpiling, and final placement as shown on the project drawings. The existing riprap is estimated as follows: 3-ton rock – 970 tons, 1-ton rock – 255 tons, and smaller miscellaneous rock as shown on the project drawings. All removed riprap and rock shall be stockpiled onsite in an area designated by the Contractor for later use. Final placement of all stockpiled riprap and rock shall be as shown on the project drawings and as directed by the Engineer. Export of any removed riprap and rock will not be permitted.

21.3 Air-Blasting - The contract item Air-Blasting includes all costs associated with the air-blasting of existing levee paneling following excavation. Air-Blasting of the proposed overlapping panel areas will ensure the removal of all loose particles and debris. Such air-blasting activities shall ensure a clean, roughened, usable surface ready to accept fresh concrete for new levee panel toe down extension construction. New levee panel toe down extension construction shall not commence until the overlapping surface is to the satisfaction of the Engineer.

21.4 Existing 4" Unreinforced Concrete Slope Paneling Breaking and Removal, Temporary Stockpiling and Final Placement - The contract item Existing 4" Unreinforced Concrete Slope Paneling Breaking and Removal, Temporary Stockpiling and Final Placement includes all costs associated with the breaking and removal, temporary stockpiling of all broken concrete within the excavation area, and final placement as shown on the project drawings. All removed broken concrete shall be stockpiled onsite in an area designated by the Contractor for his convenience for later use. Final placement of all broken concrete shall be as shown on the project drawings and as directed by the Engineer. The Contractor will endeavor to break such unreinforced concrete into pieces approximately 24" square.

21.5 Toe Extension Epoxy - The contract item Toe Extension Epoxy includes all costs associated with the furnishing, preparation, and placement of epoxy along the entire edge of new levee panel construction as shown on the project drawings and as directed by the Engineer. Toe Extension Epoxy shall consist of Sikadur 32, Hi-Mod, or approved equal and be a moisture-tolerant structural epoxy adhesive rated for bonding to concrete.

21.6 Perimeter Demarcation Fencing - The contract item Perimeter Demarcation Fencing shall consist of the furnishing and installation of such fencing as indicated on the project drawings. The Perimeter Demarcation Fencing shall consist of Uline Model No. S-14713 1.8"x1.8" Orange Safety Fence or approved equal. Fencing shall be securely affixed to stable posts and placed at an interval to the satisfaction of the Engineer. It is the sole responsibility of the Contractor to maintain the Perimeter Demarcation Fencing at all times to prevent disturbance beyond the marked limits of grading.

21.7 Extra Directed Work - The contract item Extra Directed Work shall consist of necessary work that is not included in other contract bid items and not shown on the project drawings, as determined by the Engineer. All Extra Directed Work shall be performed only as directed by the Engineer and in accordance with all applicable standards and specifications.

21.8 Measurement - No measurement will be made for lump sum contract items Existing Riprap Removal, Temporary Stockpiling and Final Placement; Air-Blasting; Existing 4" Unreinforced Concrete Slope Paneling Breaking and Removal, Temporary Stockpiling and Final Placement; and Toe Extension Epoxy.

Measurement for payment of the contract item Toe Extension Epoxy will be the number of lineal feet measured along the top edge of the toe down extension as shown on the project drawings.

Measurement for payment of the contract item Perimeter Demarcation Fencing will be the number of lineal feet of fencing installed as specified. No payment will be made for maintenance, repair, and replacement of such fencing.

21.9 Payment - The contract prices paid for Existing Riprap Removal, Temporary Stockpiling and Final Placement; Air-Blasting; Existing 4" Unreinforced Concrete Slope Paneling Breaking and Removal, Temporary Stockpiling and Final Placement; Toe Extension Epoxy; and Perimeter Demarcation Fencing shall include full compensation for all costs incurred under this section.

Payment of the contract item Perimeter Demarcation Fencing is contingent upon the adequate implementation, maintenance, and replacement of such fencing as shown on the project drawings.

Full compensation for the contract item Extra Directed Work shall be as "Extra Work" and shall be paid pursuant to Section 2.07 of the General Provisions. The total accumulated costs for Extra Directed Work shall not exceed the amount specified in the contract bid item unless otherwise increased by change order.

SECTION 22 THROUGH SECTION 26 - NOT USED

SECTION 27 - DUST ABATEMENT

27.1 Description - This section covers the implementation of dust control measures necessary to prevent harm and nuisance from dust. Supplementing Section 8.06 of the General Provisions, the Contractor shall comply with all the provisions of the South Coast Air Quality Management District (SCAQMD) Rule 403 and Rule 403.1 as described in Appendix "A".

27.2 Dust Abatement - The contract item Dust Abatement includes the action necessary to prevent, reduce or control dust within the work area as required to complete the work. The Contractor shall carry out proper and efficient measures to prevent his operations from producing dust in amounts damaging to property or causing a nuisance or harm to persons living nearby or occupying buildings in the vicinity of the work.

The Contractor shall implement appropriate fugitive dust control measures including watering, stabilized construction access to reduce tracking of mud or dirt onto public roads, covering trucks hauling loose dirt offsite and street sweeping of track-out. The Contractor can contact SCAQMD for their Rule 403 and Rule 403.1 implementation handbooks which contain a detailed listing of reasonably available dust control measures. However, due to regulatory permit restrictions, watering shall be the only method used for controlling dust in the construction areas and haul routes.

While SCAQMD Rule 403 and Rule 403.1 are exempt during emergency maintenance or such operations that may impact an endangered species, this does not relieve the Contractor from taking sufficient action to control dust. The District is requiring the following dust control

measures to be implemented or provided and approved by the Engineer prior to commencement of work:

- Proposed phasing of work and rough schedule of excavation activities
- Location of water supply and sources of backup water supply
- Specify the number and type of watering vehicles
- Street cleaning frequency
- Continuous watering of equipment paths
- Ensure adequate training of personnel

Watering of excavated material or graded areas shall be sufficient to prevent excessive dust. Watering shall occur at least three times daily in active construction areas and previously graded areas that have been inactive for ten days or more. Preferably watering should occur in the late morning and after operations have ceased for the day.

Watering trucks for dust abatement should limit their operation to the embankment access road whenever feasible. The Contractor will not be permitted to use any form of chemical stabilizers for fugitive dust prevention.

Construction equipment idling shall not exceed 10 minutes to ensure that the SCAQMD daily thresholds are not exceeded.

27.3 Payment - The contract lump sum price paid for Dust Abatement shall include full compensation for all direct and indirect costs incurred under this section.

This payment will be made on a basis of the percentage of work completed on the entire project.

SECTION 28 - NOT USED

SECTION 29 - STORMWATER AND NON-STORMWATER POLLUTION CONTROL

29.1 Description - The contract items Stormwater and Non-Stormwater Pollution Control; and Non-Stormwater Discharge or Dewatering shall include preparing, obtaining approval of, amending and implementing Contractor's Pollution Prevention Plan (PPP). The PPP shall identify site specific Best Management Practices (BMPs) to be implemented during and after construction to minimize the potential pollution of stormwater runoff and receiving waters. The identified BMPs shall be practices designed to minimize or eliminate the discharge of pollutants from the construction site and Contractor's construction activities, including, but not limited to:

1. Good housekeeping practices for solid and sanitary/septic waste management, vehicle and equipment cleaning/maintenance, and material handling and storage.
2. Construction procedures such as stabilized construction access points, scheduling/phasing to minimize areas of soil disturbance, soil stabilization and erosion/sediment control.

The PPP shall also stipulate an ongoing program for monitoring and maintenance of all BMPs.

29.2 General Requirements - Stormwater and Non-Stormwater Pollution Control work shall conform to the requirements in the latest version of Caltrans Storm Water Quality Handbooks, entitled "**Construction Site Best Management Practices (BMPs) Manual**" and "**Storm Water Pollution Prevention Plan (SWPPP) and Water Pollution Control Program (WPCP) Preparation Manual**". Copies of the "Construction Site BMPs Manual" and "SWPPP and WPCP Preparation Manual", hereafter referred to collectively as the "Caltrans Handbooks", may be obtained from the California Department of Transportation Publication Distribution Unit, 1900 Royal Oaks Drive, Sacramento, California, 95815-3800. Telephone: (916) 445-3520. Copies of the Caltrans Handbooks can also be downloaded from the Caltrans internet site at <http://www.dot.ca.gov/hq/construc/stormwater/manuals.htm>. In addition, copies of the Caltrans Handbooks are available for review at the District's office.

In the event the District incurs any Administrative Civil Liability or Mandatory Minimum Penalty (fine) imposed by the California Regional Water Quality Control Board, as a result of Contractor's failure to fully implement the provisions of this section and permit requirements, "Stormwater and Non-Stormwater Pollution Control", the Engineer may, in the exercise of his sole judgment and discretion, withhold from payments otherwise due Contractor a sufficient amount to cover the Civil Liability. Liability for "Negligent Violations" may be in an amount up to \$50,000 per day per deemed occurrence while "Knowing Violations" can result in fines as high as \$250,000 and imprisonment.

The Contractor shall be responsible for all costs and for any liability imposed by law as a result of the Contractor's failure to comply with the requirements set forth in this section, "Stormwater and Non-Stormwater Pollution Control", including but not limited to, compliance with the applicable provisions of the Caltrans Handbooks, and Federal, State, and local regulations. For the purpose of this paragraph, costs and liabilities include, but are not limited to, fines, penalties and damages whether assessed against the District or the Contractor, including those levied under the Federal Clean Water Act and the State Porter-Cologne Water Quality Act.

The Contractor shall become fully informed of and comply with the applicable provisions of the Caltrans Handbooks, and Federal, State and local regulations that govern the Contractor's activities and operation pertaining to both stormwater and non-stormwater discharges from both the project site and areas of disturbance outside the project limits during construction. The Contractor shall, at all times, keep copies of the approved PPP and all amendments at the project site. The PPP shall be made available upon request of a representative of the SWRCB, CRWQCB, United States Environmental Protection Agency (USEPA) or local stormwater management agency. Requests by the public shall be directed to the Engineer.

The Contractor is solely and exclusively responsible for any arrangements made between the Contractor and other property owners or entities that result in disturbance of areas or construction activities being conducted outside the limits of the designated rights-of-way and temporary construction easements as shown on the project drawings.

29.3 Pollution Prevention Plan Preparation and Approval - The Contractor shall prepare and obtain approval of the PPP as part of the Stormwater and Non-Stormwater Pollution Control work for this contract. The Contractor shall prepare the PPP in accordance with Section 3, "Preparing a Water Pollution Control Program (WPCP)", of the Caltrans Storm Water Quality Handbooks, entitled "**Storm Water Pollution Prevention Plan (SWPPP) and Water Pollution Control Program (WPCP) Preparation Manual**" and these Detailed Specifications.

In case of conflict between the Caltrans Handbooks and these Detailed Specifications, the Detailed Specifications shall govern.

PPP - For the convenience of the Contractor and to expedite the PPP preparation and approval, a "90%" PPP Template has been prepared by the District. This PPP template has been tailored to the referenced project and can be downloaded from http://rcflood.org/Documents/PPP_Template_600004093.pdf. Winning bidder will be provided a Word document of the "90%" PPP template to amend. The Contractor shall review and amend this PPP template based on the construction schedule and work plan proposed by the Contractor. The Contractor shall then submit a PPP certified by the Contractor's QSD which conforms to Section 29.3 for District review and approval.

Within five (5) working days after the award of the contract, the Contractor shall submit two (2) copies of the PPP to the Engineer for review and approval. The Contractor shall allow ten (10) working days for the Engineer to review the PPP. If revisions are required as determined by the Engineer, the Contractor shall revise and resubmit the PPP within three (3) working days of receipt of the Engineer's comments and shall allow ten (10) working days for the Engineer to review the revisions. The Contractor shall submit four (4) hard copies and one (1) pdf copy of the approved PPP to the Engineer prior to the pre-construction meeting. **The Contractor must have an approved PPP prior to the pre-construction meeting.**

The objectives of the PPP shall be to identify all pollution sources associated with Contractor's construction activities that may adversely affect the quality of stormwater discharges and receiving waters; to identify all non-stormwater discharges; to identify, construct, implement and maintain water pollution control best management practices, hereafter referred to as "BMPs"; to reduce to the maximum extent practicable pollutants in both stormwater and authorized non-stormwater discharges from the construction site during construction; and to develop a maintenance schedule for BMPs after construction is completed under this contract.

The PPP shall incorporate BMPs in each of the following categories:

1. Soil stabilization practices;
2. Sediment control practices;
3. Sediment tracking control practices;
4. Wind erosion control practices; and
5. Non-stormwater management, and waste management and disposal control practices.

Specific objectives and minimum requirements for each category of BMPs are contained in the Caltrans Handbooks. The Contractor shall consider the objectives and minimum requirements presented in the Caltrans Handbooks for each of the above categories. When minimum requirements are listed for any category, the Contractor shall incorporate one or more of the listed minimum BMPs required into the PPP and implement them on the project to meet the pollution control objectives for the category. In addition, the Contractor shall consider other BMPs presented in the Caltrans Handbooks to supplement the minimum BMPs required when necessary to meet the objectives of the PPP. The Contractor shall document the selection process in accordance with the procedure specified in the Caltrans Handbooks.

The Contractor shall not assume that the minimum BMPs required for each category presented in the Caltrans Handbooks are adequate to meet the pollution control objectives. The Contractor may use other effective BMPs, as approved by the Engineer, in addition to the minimum BMPs required in the Caltrans Handbooks to achieve the pollution control objectives.

The PPP shall include all of the following items in the order given below:

1. Title Page;
2. Table of Contents;
3. Project Description and Contractor's Certification;
4. Project Information;
5. Pollution Sources and BMPs;
6. Water Pollution Control Drawings;
7. A copy of the Amendments, if any;
8. Amendment Log;
9. Maintenance, Inspection, and Repair Program;
10. Inspection Log;
11. Construction Site Inspection Checklist;
12. Current Inventory of BMP related materials; and
13. Mobilization Plan for BMP deployment.

The following notes (or notes of substantially similar intent) that address pollution prevention to the Maximum Extent Practicable during the construction phase of a project on a year-round basis need to be placed on the Stormwater and Non-Stormwater Pollution Control Drawings:

- ◆ Erosion control BMPs shall be implemented and maintained to minimize and/or prevent the entrainment of soil in runoff from disturbed soil areas on construction sites.
- ◆ Sediment control BMPs shall be implemented and maintained to prevent and/or minimize the transport of soil from the construction site.
- ◆ Stockpiles of soil shall be properly contained to eliminate or reduce sediment transport from the site to streets, drainage facilities or adjacent properties via runoff, vehicle tracking or wind.

- ◆ Appropriate BMPs for construction-related materials, wastes, spills or residues shall be implemented to eliminate or reduce transport from the site to streets, drainage facilities or adjoining properties by wind or runoff.
- ◆ Runoff from equipment and vehicle washing shall be contained at construction sites and must not be discharged to receiving waters or the local storm drain system. Washwaters or rinsate from ready mix, concrete, or cement vehicles must be handled appropriately and may not be discharged to receiving waters or the storm drain system.
- ◆ All construction contractor and subcontractor personnel are to be made aware of the required best management practices and good housekeeping measures for the project site and any associated construction staging areas.
- ◆ At the end of each day of construction activity all construction debris and waste materials shall be collected and properly disposed in trash or recycle bins.
- ◆ Construction sites shall be maintained in such a condition that a storm does not carry wastes or pollutants off the site. Discharges other than stormwater (non-stormwater discharges) are prohibited, except as authorized by an individual NPDES permit, the State-wide General Permit for Storm Water Discharges Associated with Construction Activity. Potential pollutants include but are not limited to: solid or liquid chemical spills; wastes from paints, stains, sealants, solvents, detergents, glues, lime, pesticides, herbicides, fertilizers, wood preservatives and asbestos fibers; paint flakes or stucco fragments; fuels, oils, lubricants and hydraulic, radiator or battery fluids; concrete and related cutting or curing residues; floatable wastes; wastes from engine/equipment steam cleaning or chemical degreasing; wastes from street cleaning; and super-chlorinated potable water from line flushing and testing. During construction, disposal of such materials should occur in a specified and controlled temporary area onsite physically separated from potential stormwater runoff, with ultimate disposal in accordance with local, State and Federal requirements.
- ◆ Discharging contaminated groundwater produced by dewatering groundwater that has infiltrated into the construction site is prohibited. Discharging of contaminated soils via surface erosion is also prohibited.
- ◆ The Contractor is required to notify and obtain approval from the District ten (10) days prior to any non-stormwater discharge or dewatering associated with Contractor's construction activities.
- ◆ Construction sites shall be managed to minimize the exposure time of disturbed soil areas through phasing and scheduling of grading to the extent feasible and the use of temporary and permanent soil stabilization.
- ◆ BMPs shall be maintained at all times. In addition, BMPs shall be inspected prior to predicted storm events and following storm events.

29.4 Pollution Prevention Plan Amendments - The Contractor shall prepare amendments to the PPP, both graphically and in narrative form, whenever there is a change in Contractor's construction activities or operations which may result in the discharge of pollutants to surface waters, groundwaters, municipal storm drain systems or when deemed necessary by the Engineer. The Contractor shall also amend the PPP if it is not effectively achieving the

objectives of reducing pollutants in stormwater discharges. Amendments shall show additional BMPs or revisions to Contractor's construction activities or operations (including any construction activities in areas not included in the initially approved PPP) which are required on the project to effectively control water pollution.

Amendments to the PPP shall be submitted for review and approval by the Engineer in the same manner specified for the initial approval of the PPP. The Contractor shall date and attach all approved amendments to the PPP. Upon approval of the amendment, the Contractor shall implement the additional BMPs, revised construction activities or operations as described therein.

29.5 Pollution Prevention Plan Implementation - Upon approval of the PPP, the Contractor shall be responsible throughout the duration of the project for installing, constructing, inspecting and maintaining the BMPs included in the PPP and any amendments thereto and for removing and disposing of temporary BMPs. Unless otherwise directed by the Engineer or specified in these Detailed Specifications, the Contractor's responsibility for PPP implementation and maintenance shall continue throughout any temporary suspension of work ordered in accordance with Section 6.05, TEMPORARY SUSPENSION OF THE WORK, of the General Provisions. Requirements for installation, construction, inspection, maintenance, removal and disposal of BMPs are specified in the Caltrans Handbooks and these Detailed Specifications. The Contractor shall implement the PPP in accordance with the Caltrans Handbooks and these Detailed Specifications.

The Engineer may order the suspension of construction operations if the Contractor fails to comply with the requirements of this section, "Stormwater and Non-Stormwater Pollution Control", as determined by the Engineer.

- (a) Stormwater Pollution Control - **The Contractor shall implement soil stabilization practices and sediment control BMPs, including minimum requirements as presented in the Caltrans Handbooks, on all disturbed areas of the project site during the rainy season, although undefined shall be August 1st - October 1st and November 1st - May 1st, which is consistent with Caltrans' definition of the rainy season for the eastern desert region.**

Implementation of soil stabilization practices and sediment control BMPs for soil-disturbed areas, including but not limited to, rough graded access roads, slopes, channel inverts, operational inlets and outlets of the project site shall be completed no later than ten (10) calendar days prior to the start of the winter season or upon start of applicable Contractor's construction activities for projects which begin either during or within ten (10) calendar days of the winter season.

The Contractor shall demonstrate the ability and preparedness to fully deploy soil stabilization practices and sediment control BMPs to protect soil-disturbed areas of the project site by maintaining an adequate quantity of soil stabilization and sediment control materials onsite to protect exposed, soil-disturbed areas and a detailed plan for the mobilization of sufficient labor and equipment to fully

deploy the required BMPs prior to the onset of precipitation and for the duration of the project.

Throughout the winter season, active soil-disturbed areas of the project site shall be fully protected at the end of each day with soil stabilization practices and sediment control BMPs. The Contractor shall monitor the weather forecast on a daily basis. The National Weather Service forecast shall be used or an alternative weather forecast proposed by the Contractor may be used if approved by the Engineer. If precipitation is predicted prior to the end of the following workday, construction scheduling shall be modified, as required, and the Contractor shall deploy functioning control measures prior to the onset of the precipitation.

Throughout the winter season, soil-disturbed areas of the project site shall be considered to be non-active whenever soil disturbing activities are expected to be discontinued for a period of fifteen (15) calendar days or more. Areas that will become non-active either during the winter season or within ten (10) calendar days thereof shall be fully protected with soil stabilization practices such as covering with mulch, temporary seeding, fiber rolls, blankets, etc. within ten (10) calendar days of the discontinuance of soil disturbing activities or prior to the onset of precipitation, whichever is first to occur. Areas that will become non-active either during the winter season or within ten (10) calendar days thereof shall be fully protected with sediment control BMPs within ten (10) calendar days of the discontinuance of soil disturbing activities or prior to the onset of precipitation, whichever is first to occur.

- (b) **Non-Stormwater Pollution Control - The Contractor shall implement, year-round and throughout the duration of the project, BMPs included in the PPP for sediment tracking, wind erosion, non-stormwater management, and waste management and disposal.**
- (c) Inspections and Reporting - The Contractor shall regularly inspect the construction site for BMPs identified in the PPP to ensure the proper implementation and functioning of BMPs. The Contractor shall identify corrective actions and time frames to address any deficient BMPs or reinstate any BMPs that have been discontinued.

At a minimum, the Contractor shall inspect the construction site as follows:

1. Prior to a forecast storm;
2. After any precipitation which causes runoff capable of carrying sediment from the construction site;
3. At 24 hour intervals during extended precipitation events; and
4. At a regular interval of once every 2 weeks.

The construction site inspection checklist provided in the Caltrans Handbooks shall be used to ensure that the necessary BMPs are being properly implemented

and are functioning adequately. The Contractor shall submit one copy of each site inspection record to the Engineer.

- (d) Maintenance - The Contractor shall maintain construction site BMPs identified in the PPP to ensure the proper implementation and functioning of BMPs. If the Contractor or the Engineer identifies a deficiency in the deployment or functioning of an identified BMP, the deficiency shall be corrected by the Contractor immediately, or by a later date and time if requested by the Contractor and approved by the Engineer in writing, but not later than the onset of subsequent precipitation events. The correction of deficiencies shall be at no additional cost to the District.
- (e) Training - The Contractor shall describe the types of training that the Contractor's BMP inspection, maintenance and repair personnel have received or will receive that is directly related to stormwater pollution prevention.

29.6 Non-Stormwater Discharge or Dewatering - **Dewatering activity should only be considered after other methods have been determined to be inadequate for storm drain construction by the Engineer.** If groundwater will be encountered during the project activities, the dewatering activity must be covered by the General Waste Discharge Requirements for Low Threat Discharges to Surface Waters within the Colorado River Basin Region (De Minimus Permit), Colorado River Basin Regional Water Quality Control Board Order No. R7-2015-0006. The Contractor shall comply with this Order, and notify and obtain approval from the Engineer fifteen (15) days prior to any non-stormwater discharging of groundwater dewatering. If an emergency or unforeseen dewatering activity that will discharge to Waters of the United States occurs, the Contractor shall contact the Engineer immediately.

When discharging groundwater from dewatering activities to surface waters, the Contractor shall comply with and implement the Monitoring and Reporting Program required under Order No. R7-2015-0006. This Order can be downloaded from http://www.waterboards.ca.gov/coloradoriver/board_decisions/adopted_orders/orders/2015/0006_low_threat.pdf. Under the Monitoring and Reporting Program, the Contractor shall prepare the monitoring report in accordance with Attachment E of the Order. The Contractor must submit the Monitoring Reports to the Engineer by the 15th day of each month following the monitoring period. The District will submit the Monitoring Reports to the Colorado River Basin Regional Water Quality Control Board. The Monitoring Reports shall cover the previous month's monitoring activities.

If there is any other form of non-stormwater discharge from the project to surface waters, the Contractor shall immediately contact the Engineer to determine appropriate actions required for coverage under the De Minimus Permit.

Failure of the Contractor to fully comply with this requirement may result in the suspension of construction operations and liability for any associated monitoring, fines, penalties, and remediation activities related to the discharge.

29.7 Payment - The contract lump sum price paid for contract items Stormwater and Non-Stormwater Pollution Control; and Non-Stormwater Discharge or Dewatering shall include full compensation for all direct and indirect costs incurred under this section.

Payment will be made on a basis of the percentage of work completed on the entire project.

SECTION 30 AND SECTION 31 - NOT USED

APPENDIX "A"

SOUTH COAST AIR QUALITY
MANAGEMENT DISTRICT

RULE 403 and RULE 403.1

(Adopted May 7, 1976) (Amended November 6, 1992)
(Amended July 9, 1993) (Amended February 14, 1997)
(Amended December 11, 1998)(Amended April 2, 2004)
(Amended June 3, 2005)

RULE 403. FUGITIVE DUST

(a) Purpose

The purpose of this Rule is to reduce the amount of particulate matter entrained in the ambient air as a result of anthropogenic (man-made) fugitive dust sources by requiring actions to prevent, reduce or mitigate fugitive dust emissions.

(b) Applicability

The provisions of this Rule shall apply to any activity or man-made condition capable of generating fugitive dust.

(c) Definitions

- (1) ACTIVE OPERATIONS means any source capable of generating fugitive dust, including, but not limited to, earth-moving activities, construction/demolition activities, disturbed surface area, or heavy- and light-duty vehicular movement.
- (2) AGGREGATE-RELATED PLANTS are defined as facilities that produce and / or mix sand and gravel and crushed stone.
- (3) AGRICULTURAL HANDBOOK means the region-specific guidance document that has been approved by the Governing Board or hereafter approved by the Executive Officer and the U.S. EPA. For the South Coast Air Basin, the Board-approved region-specific guidance document is the Rule 403 Agricultural Handbook dated December 1998. For the Coachella Valley, the Board-approved region-specific guidance document is the Rule 403 Coachella Valley Agricultural Handbook dated April 2, 2004.
- (4) ANEMOMETERS are devices used to measure wind speed and direction in accordance with the performance standards, and maintenance and calibration criteria as contained in the most recent Rule 403 Implementation Handbook.
- (5) BEST AVAILABLE CONTROL MEASURES means fugitive dust control actions that are set forth in Table 1 of this Rule.

- (6) BULK MATERIAL is sand, gravel, soil, aggregate material less than two inches in length or diameter, and other organic or inorganic particulate matter.
- (7) CEMENT MANUFACTURING FACILITY is any facility that has a cement kiln at the facility.
- (8) CHEMICAL STABILIZERS are any non-toxic chemical dust suppressant which must not be used if prohibited for use by the Regional Water Quality Control Boards, the California Air Resources Board, the U.S. Environmental Protection Agency (U.S. EPA), or any applicable law, rule or regulation. The chemical stabilizers shall meet any specifications, criteria, or tests required by any federal, state, or local water agency. Unless otherwise indicated, the use of a non-toxic chemical stabilizer shall be of sufficient concentration and application frequency to maintain a stabilized surface.
- (9) COMMERCIAL POULTRY RANCH means any building, structure, enclosure, or premises where more than 100 fowl are kept or maintained for the primary purpose of producing eggs or meat for sale or other distribution.
- (10) CONFINED ANIMAL FACILITY means a source or group of sources of air pollution at an agricultural source for the raising of 3,360 or more fowl or 50 or more animals, including but not limited to, any structure, building, installation, farm, corral, coop, feed storage area, milking parlor, or system for the collection, storage, or distribution of solid and liquid manure; if domesticated animals, including horses, sheep, goats, swine, beef cattle, rabbits, chickens, turkeys, or ducks are corralled, penned, or otherwise caused to remain in restricted areas for commercial agricultural purposes and feeding is by means other than grazing.
- (11) CONSTRUCTION/DEMOLITION ACTIVITIES means any on-site mechanical activities conducted in preparation of, or related to, the building, alteration, rehabilitation, demolition or improvement of property, including, but not limited to the following activities: grading, excavation, loading, crushing, cutting, planing, shaping or ground breaking.
- (12) CONTRACTOR means any person who has a contractual arrangement to conduct an active operation for another person.
- (13) DAIRY FARM is an operation on a property, or set of properties that are contiguous or separated only by a public right-of-way, that raises cows or

- produces milk from cows for the purpose of making a profit or for a livelihood. Heifer and calf farms are dairy farms.
- (14) DISTURBED SURFACE AREA means a portion of the earth's surface which has been physically moved, uncovered, destabilized, or otherwise modified from its undisturbed natural soil condition, thereby increasing the potential for emission of fugitive dust. This definition excludes those areas which have:
- (A) been restored to a natural state, such that the vegetative ground cover and soil characteristics are similar to adjacent or nearby natural conditions;
 - (B) been paved or otherwise covered by a permanent structure; or
 - (C) sustained a vegetative ground cover of at least 70 percent of the native cover for a particular area for at least 30 days.
- (15) DUST SUPPRESSANTS are water, hygroscopic materials, or non-toxic chemical stabilizers used as a treatment material to reduce fugitive dust emissions.
- (16) EARTH-MOVING ACTIVITIES means the use of any equipment for any activity where soil is being moved or uncovered, and shall include, but not be limited to the following: grading, earth cutting and filling operations, loading or unloading of dirt or bulk materials, adding to or removing from open storage piles of bulk materials, landfill operations, weed abatement through disking, and soil mulching.
- (17) DUST CONTROL SUPERVISOR means a person with the authority to expeditiously employ sufficient dust mitigation measures to ensure compliance with all Rule 403 requirements at an active operation.
- (18) FUGITIVE DUST means any solid particulate matter that becomes airborne, other than that emitted from an exhaust stack, directly or indirectly as a result of the activities of any person.
- (19) HIGH WIND CONDITIONS means that instantaneous wind speeds exceed 25 miles per hour.
- (20) INACTIVE DISTURBED SURFACE AREA means any disturbed surface area upon which active operations have not occurred or are not expected to occur for a period of 20 consecutive days.
- (21) LARGE OPERATIONS means any active operations on property which contains 50 or more acres of disturbed surface area; or any earth-moving operation with a daily earth-moving or throughput volume of 3,850 cubic

meters (5,000 cubic yards) or more three times during the most recent 365-day period.

- (22) OPEN STORAGE PILE is any accumulation of bulk material, which is not fully enclosed, covered or chemically stabilized, and which attains a height of three feet or more and a total surface area of 150 or more square feet.
- (23) PARTICULATE MATTER means any material, except uncombined water, which exists in a finely divided form as a liquid or solid at standard conditions.
- (24) PAVED ROAD means a public or private improved street, highway, alley, public way, or easement that is covered by typical roadway materials, but excluding access roadways that connect a facility with a public paved roadway and are not open to through traffic. Public paved roads are those open to public access and that are owned by any federal, state, county, municipal or any other governmental or quasi-governmental agencies. Private paved roads are any paved roads not defined as public.
- (25) PM₁₀ means particulate matter with an aerodynamic diameter smaller than or equal to 10 microns as measured by the applicable State and Federal reference test methods.
- (26) PROPERTY LINE means the boundaries of an area in which either a person causing the emission or a person allowing the emission has the legal use or possession of the property. Where such property is divided into one or more sub-tenancies, the property line(s) shall refer to the boundaries dividing the areas of all sub-tenancies.
- (27) RULE 403 IMPLEMENTATION HANDBOOK means a guidance document that has been approved by the Governing Board on April 2, 2004 or hereafter approved by the Executive Officer and the U.S. EPA.
- (28) SERVICE ROADS are paved or unpaved roads that are used by one or more public agencies for inspection or maintenance of infrastructure and which are not typically used for construction-related activity.
- (29) SIMULTANEOUS SAMPLING means the operation of two PM₁₀ samplers in such a manner that one sampler is started within five minutes of the other, and each sampler is operated for a consecutive period which must be not less than 290 minutes and not more than 310 minutes.
- (30) SOUTH COAST AIR BASIN means the non-desert portions of Los Angeles, Riverside, and San Bernardino counties and all of Orange

County as defined in California Code of Regulations, Title 17, Section 60104. The area is bounded on the west by the Pacific Ocean, on the north and east by the San Gabriel, San Bernardino, and San Jacinto Mountains, and on the south by the San Diego county line.

- (31) STABILIZED SURFACE means any previously disturbed surface area or open storage pile which, through the application of dust suppressants, shows visual or other evidence of surface crusting and is resistant to wind-driven fugitive dust and is demonstrated to be stabilized. Stabilization can be demonstrated by one or more of the applicable test methods contained in the Rule 403 Implementation Handbook.
 - (32) TRACK-OUT means any bulk material that adheres to and agglomerates on the exterior surface of motor vehicles, haul trucks, and equipment (including tires) that have been released onto a paved road and can be removed by a vacuum sweeper or a broom sweeper under normal operating conditions.
 - (33) TYPICAL ROADWAY MATERIALS means concrete, asphaltic concrete, recycled asphalt, asphalt, or any other material of equivalent performance as determined by the Executive Officer, and the U.S. EPA.
 - (34) UNPAVED ROADS means any unsealed or unpaved roads, equipment paths, or travel ways that are not covered by typical roadway materials. Public unpaved roads are any unpaved roadway owned by federal, state, county, municipal or other governmental or quasi-governmental agencies. Private unpaved roads are all other unpaved roadways not defined as public.
 - (35) VISIBLE ROADWAY DUST means any sand, soil, dirt, or other solid particulate matter which is visible upon paved road surfaces and which can be removed by a vacuum sweeper or a broom sweeper under normal operating conditions.
 - (36) WIND-DRIVEN FUGITIVE DUST means visible emissions from any disturbed surface area which is generated by wind action alone.
 - (37) WIND GUST is the maximum instantaneous wind speed as measured by an anemometer.
- (d) Requirements
- (1) No person shall cause or allow the emissions of fugitive dust from any active operation, open storage pile, or disturbed surface area such that:

- (A) the dust remains visible in the atmosphere beyond the property line of the emission source; or
 - (B) the dust emission exceeds 20 percent opacity (as determined by the appropriate test method included in the Rule 403 Implementation Handbook), if the dust emission is the result of movement of a motorized vehicle.
- (2) No person shall conduct active operations without utilizing the applicable best available control measures included in Table 1 of this Rule to minimize fugitive dust emissions from each fugitive dust source type within the active operation.
- (3) No person shall cause or allow PM₁₀ levels to exceed 50 micrograms per cubic meter when determined, by simultaneous sampling, as the difference between upwind and downwind samples collected on high-volume particulate matter samplers or other U.S. EPA-approved equivalent method for PM₁₀ monitoring. If sampling is conducted, samplers shall be:
- (A) Operated, maintained, and calibrated in accordance with 40 Code of Federal Regulations (CFR), Part 50, Appendix J, or appropriate U.S. EPA-published documents for U.S. EPA-approved equivalent method(s) for PM₁₀.
 - (B) Reasonably placed upwind and downwind of key activity areas and as close to the property line as feasible, such that other sources of fugitive dust between the sampler and the property line are minimized.
- (4) No person shall allow track-out to extend 25 feet or more in cumulative length from the point of origin from an active operation. Notwithstanding the preceding, all track-out from an active operation shall be removed at the conclusion of each workday or evening shift.
- (5) No person shall conduct an active operation with a disturbed surface area of five or more acres, or with a daily import or export of 100 cubic yards or more of bulk material without utilizing at least one of the measures listed in subparagraphs (d)(5)(A) through (d)(5)(E) at each vehicle egress from the site to a paved public road.
- (A) Install a pad consisting of washed gravel (minimum-size: one inch) maintained in a clean condition to a depth of at least six inches and extending at least 30 feet wide and at least 50 feet long.

- (B) Pave the surface extending at least 100 feet and at least 20 feet wide.
 - (C) Utilize a wheel shaker/wheel spreading device consisting of raised dividers (rails, pipe, or grates) at least 24 feet long and 10 feet wide to remove bulk material from tires and vehicle undercarriages before vehicles exit the site.
 - (D) Install and utilize a wheel washing system to remove bulk material from tires and vehicle undercarriages before vehicles exit the site.
 - (E) Any other control measures approved by the Executive Officer and the U.S. EPA as equivalent to the actions specified in subparagraphs (d)(5)(A) through (d)(5)(D).
- (6) Beginning January 1, 2006, any person who operates or authorizes the operation of a confined animal facility subject to this Rule shall implement the applicable conservation management practices specified in Table 4 of this Rule.
- (e) Additional Requirements for Large Operations
- (1) Any person who conducts or authorizes the conducting of a large operation subject to this Rule shall implement the applicable actions specified in Table 2 of this Rule at all times and shall implement the applicable actions specified in Table 3 of this Rule when the applicable performance standards can not be met through use of Table 2 actions; and shall:
 - (A) submit a fully executed Large Operation Notification (Form 403 N) to the Executive Officer within 7 days of qualifying as a large operation;
 - (B) include, as part of the notification, the name(s), address(es), and phone number(s) of the person(s) responsible for the submittal, and a description of the operation(s), including a map depicting the location of the site;
 - (C) maintain daily records to document the specific dust control actions taken, maintain such records for a period of not less than three years; and make such records available to the Executive Officer upon request;

- (D) install and maintain project signage with project contact signage that meets the minimum standards of the Rule 403 Implementation Handbook, prior to initiating any earthmoving activities;
 - (E) identify a dust control supervisor that:
 - (i) is employed by or contracted with the property owner or developer;
 - (ii) is on the site or available on-site within 30 minutes during working hours;
 - (iii) has the authority to expeditiously employ sufficient dust mitigation measures to ensure compliance with all Rule requirements;
 - (iv) has completed the AQMD Fugitive Dust Control Class and has been issued a valid Certificate of Completion for the class; and
 - (F) notify the Executive Officer in writing within 30 days after the site no longer qualifies as a large operation as defined by paragraph (c)(18).
- (2) Any Large Operation Notification submitted to the Executive Officer or AQMD-approved dust control plan shall be valid for a period of one year from the date of written acceptance by the Executive Officer. Any Large Operation Notification accepted pursuant to paragraph (e)(1), excluding those submitted by aggregate-related plants and cement manufacturing facilities must be resubmitted annually by the person who conducts or authorizes the conducting of a large operation, at least 30 days prior to the expiration date, or the submittal shall no longer be valid as of the expiration date. If all fugitive dust sources and corresponding control measures or special circumstances remain identical to those identified in the previously accepted submittal or in an AQMD-approved dust control plan, the resubmittal may be a simple statement of no-change (Form 403NC).
- (f) **Compliance Schedule**
The newly amended provisions of this Rule shall become effective upon adoption. Pursuant to subdivision (e), any existing site that qualifies as a large operation will have 60 days from the date of Rule adoption to comply with the notification and recordkeeping requirements for large operations. Any Large Operation

Notification or AQMD-approved dust control plan which has been accepted prior to the date of adoption of these amendments shall remain in effect and the Large Operation Notification or AQMD-approved dust control plan annual resubmittal date shall be one year from adoption of this Rule amendment.

(g) Exemptions

(1) The provisions of this Rule shall not apply to:

- (A) Dairy farms.
- (B) Confined animal facilities provided that the combined disturbed surface area within one continuous property line is one acre or less.
- (C) Agricultural vegetative crop operations provided that the combined disturbed surface area within one continuous property line and not separated by a paved public road is 10 acres or less.
- (D) Agricultural vegetative crop operations within the South Coast Air Basin, whose combined disturbed surface area includes more than 10 acres provided that the person responsible for such operations:
 - (i) voluntarily implements the conservation management practices contained in the Rule 403 Agricultural Handbook;
 - (ii) completes and maintains the self-monitoring form documenting sufficient conservation management practices, as described in the Rule 403 Agricultural Handbook; and
 - (iii) makes the completed self-monitoring form available to the Executive Officer upon request.
- (E) Agricultural vegetative crop operations outside the South Coast Air Basin whose combined disturbed surface area includes more than 10 acres provided that the person responsible for such operations:
 - (i) voluntarily implements the conservation management practices contained in the Rule 403 Coachella Valley Agricultural Handbook; and
 - (ii) completes and maintains the self-monitoring form documenting sufficient conservation management practices, as described in the Rule 403 Coachella Valley Agricultural Handbook; and
 - (iii) makes the completed self-monitoring form available to the Executive Officer upon request.

- (F) Active operations conducted during emergency life-threatening situations, or in conjunction with any officially declared disaster or state of emergency.
 - (G) Active operations conducted by essential service utilities to provide electricity, natural gas, telephone, water and sewer during periods of service outages and emergency disruptions.
 - (H) Any contractor subsequent to the time the contract ends, provided that such contractor implemented the required control measures during the contractual period.
 - (I) Any grading contractor, for a phase of active operations, subsequent to the contractual completion of that phase of earth-moving activities, provided that the required control measures have been implemented during the entire phase of earth-moving activities, through and including five days after the final grading inspection.
 - (J) Weed abatement operations ordered by a county agricultural commissioner or any state, county, or municipal fire department, provided that:
 - (i) mowing, cutting or other similar process is used which maintains weed stubble at least three inches above the soil; and
 - (ii) any discing or similar operation which cuts into and disturbs the soil, where watering is used prior to initiation of these activities, and a determination is made by the agency issuing the weed abatement order that, due to fire hazard conditions, rocks, or other physical obstructions, it is not practical to meet the conditions specified in clause (g)(1)(H)(i). The provisions this clause shall not exempt the owner of any property from stabilizing, in accordance with paragraph (d)(2), disturbed surface areas which have been created as a result of the weed abatement actions.
 - (K) sandblasting operations.
- (2) The provisions of paragraphs (d)(1) and (d)(3) shall not apply:
- (A) When wind gusts exceed 25 miles per hour, provided that:

- (i) The required Table 3 contingency measures in this Rule are implemented for each applicable fugitive dust source type, and;
 - (ii) records are maintained in accordance with subparagraph (e)(1)(C).
 - (B) To unpaved roads, provided such roads:
 - (i) are used solely for the maintenance of wind-generating equipment; or
 - (ii) are unpaved public alleys as defined in Rule 1186; or
 - (iii) are service roads that meet all of the following criteria:
 - (a) are less than 50 feet in width at all points along the road;
 - (b) are within 25 feet of the property line; and
 - (c) have a traffic volume less than 20 vehicle-trips per day.
 - (C) To any active operation, open storage pile, or disturbed surface area for which necessary fugitive dust preventive or mitigative actions are in conflict with the federal Endangered Species Act, as determined in writing by the State or federal agency responsible for making such determinations.
- (3) The provisions of (d)(2) shall not apply to any aggregate-related plant or cement manufacturing facility that implements the applicable actions specified in Table 2 of this Rule at all times and shall implement the applicable actions specified in Table 3 of this Rule when the applicable performance standards of paragraphs (d)(1) and (d)(3) can not be met through use of Table 2 actions.
 - (4) The provisions of paragraphs (d)(1), (d)(2), and (d)(3) shall not apply to:
 - (A) Blasting operations which have been permitted by the California Division of Industrial Safety; and
 - (B) Motion picture, television, and video production activities when dust emissions are required for visual effects. In order to obtain this exemption, the Executive Officer must receive notification in writing at least 72 hours in advance of any such activity and no nuisance results from such activity.
 - (5) The provisions of paragraph (d)(3) shall not apply if the dust control actions, as specified in Table 2, are implemented on a routine basis for

each applicable fugitive dust source type. To qualify for this exemption, a person must maintain records in accordance with subparagraph (e)(1)(C).

- (6) The provisions of paragraph (d)(4) shall not apply to earth coverings of public paved roadways where such coverings are approved by a local government agency for the protection of the roadway, and where such coverings are used as roadway crossings for haul vehicles provided that such roadway is closed to through traffic and visible roadway dust is removed within one day following the cessation of activities.
- (7) The provisions of subdivision (e) shall not apply to:
 - (A) officially-designated public parks and recreational areas, including national parks, national monuments, national forests, state parks, state recreational areas, and county regional parks.
 - (B) any large operation which is required to submit a dust control plan to any city or county government which has adopted a District-approved dust control ordinance.
 - (C) any large operation subject to Rule 1158, which has an approved dust control plan pursuant to Rule 1158, provided that all sources of fugitive dust are included in the Rule 1158 plan.
- (8) The provisions of subparagraph (e)(1)(A) through (e)(1)(C) shall not apply to any large operation with an AQMD-approved fugitive dust control plan provided that there is no change to the sources and controls as identified in the AQMD-approved fugitive dust control plan.

(h) Fees

Any person conducting active operations for which the Executive Officer conducts upwind/downwind monitoring for PM₁₀ pursuant to paragraph (d)(3) shall be assessed applicable Ambient Air Analysis Fees pursuant to Rule 304.1. Applicable fees shall be waived for any facility which is exempted from paragraph (d)(3) or meets the requirements of paragraph (d)(3).

TABLE 1
BEST AVAILABLE CONTROL MEASURES
(Applicable to All Construction Activity Sources)

Source Category	Control Measure	Guidance
Backfilling	01-1 Stabilize backfill material when not actively handling; and 01-2 Stabilize backfill material during handling; and 01-3 Stabilize soil at completion of activity.	<ul style="list-style-type: none"> ✓ Mix backfill soil with water prior to moving ✓ Dedicate water truck or high capacity hose to backfilling equipment ✓ Empty loader bucket slowly so that no dust plumes are generated ✓ Minimize drop height from loader bucket
Clearing and grubbing	02-1 Maintain stability of soil through pre-watering of site prior to clearing and grubbing; and 02-2 Stabilize soil during clearing and grubbing activities; and 02-3 Stabilize soil immediately after clearing and grubbing activities.	<ul style="list-style-type: none"> ✓ Maintain live perennial vegetation where possible ✓ Apply water in sufficient quantity to prevent generation of dust plumes
Clearing forms	03-1 Use water spray to clear forms; or 03-2 Use sweeping and water spray to clear forms; or 03-3 Use vacuum system to clear forms.	<ul style="list-style-type: none"> ✓ Use of high pressure air to clear forms may cause exceedance of Rule requirements
Crushing	04-1 Stabilize surface soils prior to operation of support equipment; and 04-2 Stabilize material after crushing.	<ul style="list-style-type: none"> ✓ Follow permit conditions for crushing equipment ✓ Pre-water material prior to loading into crusher ✓ Monitor crusher emissions opacity ✓ Apply water to crushed material to prevent dust plumes

TABLE 1
BEST AVAILABLE CONTROL MEASURES
(Applicable to All Construction Activity Sources)

Source Category	Control Measure	Guidance
Cut and fill	05-1 Pre-water soils prior to cut and fill activities; and 05-2 Stabilize soil during and after cut and fill activities.	<ul style="list-style-type: none"> ✓ For large sites, pre-water with sprinklers or water trucks and allow time for penetration ✓ Use water trucks/pulls to water soils to depth of cut prior to subsequent cuts
Demolition – mechanical/manual	06-1 Stabilize wind erodible surfaces to reduce dust; and 06-2 Stabilize surface soil where support equipment and vehicles will operate; and 06-3 Stabilize loose soil and demolition debris; and 06-4 Comply with AQMD Rule 1403.	<ul style="list-style-type: none"> ✓ Apply water in sufficient quantities to prevent the generation of visible dust plumes
Disturbed soil	07-1 Stabilize disturbed soil throughout the construction site; and 07-2 Stabilize disturbed soil between structures	<ul style="list-style-type: none"> ✓ Limit vehicular traffic and disturbances on soils where possible ✓ If interior block walls are planned, install as early as possible ✓ Apply water or a stabilizing agent in sufficient quantities to prevent the generation of visible dust plumes
Earth-moving activities	08-1 Pre-apply water to depth of proposed cuts; and 08-2 Re-apply water as necessary to maintain soils in a damp condition and to ensure that visible emissions do not exceed 100 feet in any direction; and 08-3 Stabilize soils once earth-moving activities are complete.	<ul style="list-style-type: none"> ✓ Grade each project phase separately, timed to coincide with construction phase ✓ Upwind fencing can prevent material movement on site ✓ Apply water or a stabilizing agent in sufficient quantities to prevent the generation of visible dust plumes

TABLE 1
BEST AVAILABLE CONTROL MEASURES
 (Applicable to All Construction Activity Sources)

Source Category	Control Measure	Guidance
Importing/exporting of bulk materials	09-1 Stabilize material while loading to reduce fugitive dust emissions; and 09-2 Maintain at least six inches of freeboard on haul vehicles; and 09-3 Stabilize material while transporting to reduce fugitive dust emissions; and 09-4 Stabilize material while unloading to reduce fugitive dust emissions; and 09-5 Comply with Vehicle Code Section 23114.	<ul style="list-style-type: none"> ✓ Use tarps or other suitable enclosures on haul trucks ✓ Check belly-dump truck seals regularly and remove any trapped rocks to prevent spillage ✓ Comply with track-out prevention/mitigation requirements ✓ Provide water while loading and unloading to reduce visible dust plumes
Landscaping	10-1 Stabilize soils, materials, slopes	<ul style="list-style-type: none"> ✓ Apply water to materials to stabilize ✓ Maintain materials in a crusted condition ✓ Maintain effective cover over materials ✓ Stabilize sloping surfaces using soil binders until vegetation or ground cover can effectively stabilize the slopes ✓ Hydroseed prior to rain season
Road shoulder maintenance	11-1 Apply water to unpaved shoulders prior to clearing; and 11-2 Apply chemical dust suppressants and/or washed gravel to maintain a stabilized surface after completing road shoulder maintenance.	<ul style="list-style-type: none"> ✓ Installation of curbing and/or paving of road shoulders can reduce recurring maintenance costs ✓ Use of chemical dust suppressants can inhibit vegetation growth and reduce future road shoulder maintenance costs

TABLE 1
BEST AVAILABLE CONTROL MEASURES
(Applicable to All Construction Activity Sources)

Source Category	Control Measure	Guidance
Screening	12-1 Pre-water material prior to screening; and 12-2 Limit fugitive dust emissions to opacity and plume length standards; and 12-3 Stabilize material immediately after screening.	<ul style="list-style-type: none"> ✓ Dedicate water truck or high capacity hose to screening operation ✓ Drop material through the screen slowly and minimize drop height ✓ Install wind barrier with a porosity of no more than 50% upwind of screen to the height of the drop point
Staging areas	13-1 Stabilize staging areas during use; and 13-2 Stabilize staging area soils at project completion.	<ul style="list-style-type: none"> ✓ Limit size of staging area ✓ Limit vehicle speeds to 15 miles per hour ✓ Limit number and size of staging area entrances/exits
Stockpiles/ Bulk Material Handling	14-1 Stabilize stockpiled materials. 14-2 Stockpiles within 100 yards of off-site occupied buildings must not be greater than eight feet in height; or must have a road bladed to the top to allow water truck access or must have an operational water irrigation system that is capable of complete stockpile coverage.	<ul style="list-style-type: none"> ✓ Add or remove material from the downwind portion of the storage pile ✓ Maintain storage piles to avoid steep sides or faces

TABLE 1
BEST AVAILABLE CONTROL MEASURES
 (Applicable to All Construction Activity Sources)

Source Category	Control Measure	Guidance
Traffic areas for construction activities	15-1 Stabilize all off-road traffic and parking areas; and 15-2 Stabilize all haul routes; and 15-3 Direct construction traffic over established haul routes.	<ul style="list-style-type: none"> ✓ Apply gravel/paving to all haul routes as soon as possible to all future roadway areas ✓ Barriers can be used to ensure vehicles are only used on established parking areas/haul routes
Trenching	16-1 Stabilize surface soils where trencher or excavator and support equipment will operate; and 16-2 Stabilize soils at the completion of trenching activities.	<ul style="list-style-type: none"> ✓ Pre-watering of soils prior to trenching is an effective preventive measure. For deep trenching activities, pre-trench to 18 inches soak soils via the pre-trench and resuming trenching ✓ Washing mud and soils from equipment at the conclusion of trenching activities can prevent crusting and drying of soil on equipment
Truck loading	17-1 Pre-water material prior to loading; and 17-2 Ensure that freeboard exceeds six inches (CVC 23114)	<ul style="list-style-type: none"> ✓ Empty loader bucket such that no visible dust plumes are created ✓ Ensure that the loader bucket is close to the truck to minimize drop height while loading
Turf Overseeding	18-1 Apply sufficient water immediately prior to conducting turf vacuuming activities to meet opacity and plume length standards; and 18-2 Cover haul vehicles prior to exiting the site.	<ul style="list-style-type: none"> ✓ Haul waste material immediately off-site

TABLE 1
BEST AVAILABLE CONTROL MEASURES
(Applicable to All Construction Activity Sources)

Source Category	Control Measure	Guidance
Unpaved roads/parking lots	19-1 Stabilize soils to meet the applicable performance standards; and 19-2 Limit vehicular travel to established unpaved roads (haul routes) and unpaved parking lots.	✓ Restricting vehicular access to established unpaved travel paths and parking lots can reduce stabilization requirements
Vacant land	20-1 In instances where vacant lots are 0.10 acre or larger and have a cumulative area of 500 square feet or more that are driven over and/or used by motor vehicles and/or off-road vehicles, prevent motor vehicle and/or off-road vehicle trespassing, parking and/or access by installing barriers, curbs, fences, gates, posts, signs, shrubs, trees or other effective control measures.	

Table 2
DUST CONTROL MEASURES FOR LARGE OPERATIONS

FUGITIVE DUST SOURCE CATEGORY	CONTROL ACTIONS
Earth-moving (except construction cutting and filling areas, and mining operations)	<p>(1a) Maintain soil moisture content at a minimum of 12 percent, as determined by ASTM method D-2216, or other equivalent method approved by the Executive Officer, the California Air Resources Board, and the U.S. EPA. Two soil moisture evaluations must be conducted during the first three hours of active operations during a calendar day, and two such evaluations each subsequent four-hour period of active operations; OR</p> <p>(1a-1) For any earth-moving which is more than 100 feet from all property lines, conduct watering as necessary to prevent visible dust emissions from exceeding 100 feet in length in any direction.</p>
Earth-moving: Construction fill areas:	<p>(1b) Maintain soil moisture content at a minimum of 12 percent, as determined by ASTM method D-2216, or other equivalent method approved by the Executive Officer, the California Air Resources Board, and the U.S. EPA. For areas which have an optimum moisture content for compaction of less than 12 percent, as determined by ASTM Method 1557 or other equivalent method approved by the Executive Officer and the California Air Resources Board and the U.S. EPA, complete the compaction process as expeditiously as possible after achieving at least 70 percent of the optimum soil moisture content. Two soil moisture evaluations must be conducted during the first three hours of active operations during a calendar day, and two such evaluations during each subsequent four-hour period of active operations.</p>

Table 2 (Continued)

FUGITIVE DUST SOURCE CATEGORY	CONTROL ACTIONS
Earth-moving: Construction cut areas and mining operations:	(1c) Conduct watering as necessary to prevent visible emissions from extending more than 100 feet beyond the active cut or mining area unless the area is inaccessible to watering vehicles due to slope conditions or other safety factors.
Disturbed surface areas (except completed grading areas)	(2a/b) Apply dust suppression in sufficient quantity and frequency to maintain a stabilized surface. Any areas which cannot be stabilized, as evidenced by wind driven fugitive dust must have an application of water at least twice per day to at least 80 percent of the unstabilized area.
Disturbed surface areas: Completed grading areas	(2c) Apply chemical stabilizers within five working days of grading completion; OR (2d) Take actions (3a) or (3c) specified for inactive disturbed surface areas.
Inactive disturbed surface areas	(3a) Apply water to at least 80 percent of all inactive disturbed surface areas on a daily basis when there is evidence of wind driven fugitive dust, excluding any areas which are inaccessible to watering vehicles due to excessive slope or other safety conditions; OR (3b) Apply dust suppressants in sufficient quantity and frequency to maintain a stabilized surface; OR (3c) Establish a vegetative ground cover within 21 days after active operations have ceased. Ground cover must be of sufficient density to expose less than 30 percent of unstabilized ground within 90 days of planting, and at all times thereafter; OR (3d) Utilize any combination of control actions (3a), (3b), and (3c) such that, in total, these actions apply to all inactive disturbed surface areas.

Table 2 (Continued)

FUGITIVE DUST SOURCE CATEGORY	CONTROL ACTIONS
Unpaved Roads	(4a) Water all roads used for any vehicular traffic at least once per every two hours of active operations [3 times per normal 8 hour work day]; OR (4b) Water all roads used for any vehicular traffic once daily and restrict vehicle speeds to 15 miles per hour; OR (4c) Apply a chemical stabilizer to all unpaved road surfaces in sufficient quantity and frequency to maintain a stabilized surface.
Open storage piles	(5a) Apply chemical stabilizers; OR (5b) Apply water to at least 80 percent of the surface area of all open storage piles on a daily basis when there is evidence of wind driven fugitive dust; OR (5c) Install temporary coverings; OR (5d) Install a three-sided enclosure with walls with no more than 50 percent porosity which extend, at a minimum, to the top of the pile. This option may only be used at aggregate-related plants or at cement manufacturing facilities.
All Categories	(6a) Any other control measures approved by the Executive Officer and the U.S. EPA as equivalent to the methods specified in Table 2 may be used.

TABLE 3
CONTINGENCY CONTROL MEASURES FOR LARGE OPERATIONS

FUGITIVE DUST SOURCE CATEGORY	CONTROL MEASURES
Earth-moving	(1A) Cease all active operations; OR (2A) Apply water to soil not more than 15 minutes prior to moving such soil.
Disturbed surface areas	(0B) On the last day of active operations prior to a weekend, holiday, or any other period when active operations will not occur for not more than four consecutive days: apply water with a mixture of chemical stabilizer diluted to not less than 1/20 of the concentration required to maintain a stabilized surface for a period of six months; OR (1B) Apply chemical stabilizers prior to wind event; OR (2B) Apply water to all unstabilized disturbed areas 3 times per day. If there is any evidence of wind driven fugitive dust, watering frequency is increased to a minimum of four times per day; OR (3B) Take the actions specified in Table 2, Item (3c); OR (4B) Utilize any combination of control actions (1B), (2B), and (3B) such that, in total, these actions apply to all disturbed surface areas.
Unpaved roads	(1C) Apply chemical stabilizers prior to wind event; OR (2C) Apply water twice per hour during active operation; OR (3C) Stop all vehicular traffic.
Open storage piles	(1D) Apply water twice per hour; OR (2D) Install temporary coverings.
Paved road track-out	(1E) Cover all haul vehicles; OR (2E) Comply with the vehicle freeboard requirements of Section 23114 of the California Vehicle Code for both public and private roads.
All Categories	(1F) Any other control measures approved by the Executive Officer and the U.S. EPA as equivalent to the methods specified in Table 3 may be used.

Table 4
(Conservation Management Practices for Confined Animal Facilities)

SOURCE CATEGORY	CONSERVATION MANAGEMENT PRACTICES
Manure Handling (Only applicable to Commercial Poultry Ranches)	(1a) Cover manure prior to removing material off-site; AND (1b) Spread the manure before 11:00 AM and when wind conditions are less than 25 miles per hour; AND (1c) Utilize coning and drying manure management by removing manure at laying hen houses at least twice per year and maintain a base of no less than 6 inches of dry manure after clean out; or in lieu of complying with conservation management practice (1c), comply with conservation management practice (1d). (1d) Utilize frequent manure removal by removing the manure from laying hen houses at least every seven days and immediately thin bed dry the material.
Feedstock Handling	(2a) Utilize a sock or boot on the feed truck auger when filling feed storage bins.
Disturbed Surfaces	(3a) Maintain at least 70 percent vegetative cover on vacant portions of the facility; OR (3b) Utilize conservation tillage practices to manage the amount, orientation and distribution of crop and other plant residues on the soil surface year-round, while growing crops (if applicable) in narrow slots or tilled strips; OR (3c) Apply dust suppressants in sufficient concentrations and frequencies to maintain a stabilized surface.
Unpaved Roads	(4a) Restrict access to private unpaved roads either through signage or physical access restrictions and control vehicular speeds to no more than 15 miles per hour through worker notifications, signage, or any other necessary means; OR (4b) Cover frequently traveled unpaved roads with low silt content material (i.e., asphalt, concrete, recycled road base, or gravel to a minimum depth of four inches); OR (4c) Treat unpaved roads with water, mulch, chemical dust suppressants or other cover to maintain a stabilized surface.
Equipment Parking Areas	(5a) Apply dust suppressants in sufficient quantity and frequency to maintain a stabilized surface; OR (5b) Apply material with low silt content (i.e., asphalt, concrete, recycled road base, or gravel to a depth of four inches).

(Adopted January 15, 1993)(Amended June 16, 2000)(Amended April 2, 2004)

RULE 403.1. SUPPLEMENTAL FUGITIVE DUST CONTROL REQUIREMENTS FOR COACHELLA VALLEY SOURCES

(a) Purpose

The purpose of this rule is to reduce or prevent the amount of fine particulate matter (PM₁₀) entrained in the ambient air from anthropogenic (man-made) fugitive dust sources.

(b) Applicability

The provisions of this rule are supplemental to Rule 403 requirements and shall apply only to fugitive dust sources in the Coachella Valley.

(c) Definitions

- (1) ACTIVE OPERATIONS shall mean any source capable of generating fugitive dust, including, but not limited to, earth-moving activities, construction/demolition activities, disturbed surface areas, or agricultural operations.
- (2) AGRICULTURAL OPERATIONS means any operation occurring on a ranch or farm directly related to the growing of crops, or raising of fowls or animals for the primary purpose of making a profit or for a livelihood.
- (3) ANEMOMETERS are devices used to measure wind speed in accordance with the performance standards, maintenance and calibration criteria specified in the Rule 403.1 Implementation Handbook.
- (4) BULK MATERIAL is sand, gravel, soil, aggregate material less than two inches in length or diameter and other organic and inorganic particulate matter.
- (5) CHEMICAL STABILIZERS are any non-toxic chemical dust suppressant which must not be used if prohibited for use by the Regional Water Quality Control Boards, the California Air Resources Board, the U.S. Environmental Protection Agency (U.S. EPA), or any applicable law, rule or regulation. The chemical stabilizers shall meet any specifications, criteria, or tests required by any federal, state, or local water agency. Unless otherwise indicated, the use of a non-toxic chemical stabilizer shall be of sufficient concentration and application frequency to maintain a stabilized surface.

- (6) COACHELLA VALLEY means that portion of Riverside County, as defined in Rule 103, subdivision (h).
- (7) COACHELLA VALLEY BLOWSAND ZONE means the corridor of land extending two miles to either side of the centerline of the I-10 Freeway beginning at the SR-111/I-10 junction and continuing southeast to the I-10/ Jefferson Street interchange in Indio.
- (8) CONSTRUCTION/DEMOLITION ACTIVITIES means any on-site mechanical activities conducted in preparation of or related to, the building, alteration, rehabilitation, demolition or improvement of property, including, but not limited to the following activities: grading, excavation, loading, crushing, cutting, planing, shaping or ground breaking.
- (9) DISTURBED SURFACE AREA means a portion of the earth's surface which has been physically moved, uncovered, destabilized, or otherwise modified from its undisturbed natural soil condition, thereby increasing the potential for emission of fugitive dust. This definition excludes those areas which have:
 - (A) been restored to a natural state, such that vegetative ground cover and soil characteristics are similar to adjacent or near-by natural conditions;
 - (B) been paved or otherwise covered by a permanent structure;
 - (C) sustained a vegetative ground cover of at least 70 percent of the average native cover for a particular area for at least 30 days.
- (10) DUST CONTROL SUPERVISOR means a person with the authority to expeditiously employ sufficient dust mitigation measures to ensure compliance with all Rule 403 and Rule 403.1 requirements at an active operation.
- (11) DUST SUPPRESSANTS are water, hygroscopic materials, or non-toxic chemical stabilizers used as a treatment material to reduce fugitive emissions.
- (12) EARTH-MOVING ACTIVITIES means the use of any equipment for any activity where soil is being moved or uncovered and shall include, but not be limited to the following: such operations as grading, loading or unloading of dirt or bulk materials, adding to or removing from open storage piles of bulk materials, landfill operations, weed abatement through disking, soil mulching and agricultural tilling.

- (13) FUGITIVE DUST means any solid particulate matter that becomes airborne, other than that emitted from an exhaust stack, directly or indirectly as a result of the activities of any person.
- (14) FUGITIVE DUST CONTROL PLAN means a plan to control fugitive dust plan as described in subdivision (e).
- (15) ON-SITE means within the property lines of a property, or as otherwise approved by the Executive Officer.
- (16) OPEN STORAGE PILE is any accumulation of bulk material which is not fully enclosed, covered or chemically stabilized, and which attains a height of three feet or more and a total surface area of 150 or more square feet.
- (17) PARTICULATE MATTER means any material, except uncombined water, which exists in a finely divided form as a liquid or solid at standard conditions.
- (18) PM₁₀ means particulate matter with an aerodynamic diameter smaller than or equal to 10 microns as measured by the applicable state and federal reference test methods.
- (19) PROPERTY LINE means the boundaries of an area in which a person allowing the emission has the legal use or possession of the property. Where such property is divided into one or more sub-tenancies, the property line(s) shall refer to the boundaries dividing the areas of all sub-tenancies.
- (20) RULE 403.1 IMPLEMENTATION HANDBOOK means a guidance document that has been approved by the Governing Board on April 2, 2004 or hereafter approved by the Executive Officer and the U.S. EPA.
- (21) STABILIZED SURFACE means any previously disturbed surface area which, through the application of dust suppressants, shows visual or other evidence of surface crusting and is resistant to wind-driven fugitive dust and is demonstrated to be stabilized. Stabilization can be demonstrated by one or more of the applicable test methods contained in the Rule 403.1 Implementation Handbook.
- (22) UNPAVED ROADS means any unsealed or unpaved roads, equipment paths, or travel ways that are not covered by one of the following: concrete, asphaltic concrete, recycled asphalt, asphalt or other materials with equivalent performance as determined by the Executive Officer, the California Air Resources Board, and the U.S. EPA. Public unpaved roads

are any unpaved roadway owned by federal, state, county, municipal or other governmental or quasi-governmental agencies. Private unpaved roads are all other unpaved roadways not defined as public.

- (23) WIND-DRIVEN FUGITIVE DUST means visible emissions from any disturbed surface area which is generated by wind action alone.
 - (24) WIND GUST is the maximum instantaneous wind speed as measured by an anemometer.
- (d) General Requirements
- (1) Any person who is responsible for any active operation, open storage pile, or disturbed surface area, and who seeks an exemption pursuant to Rule 403, paragraph (g)(2) shall be required to determine when wind speed conditions exceed 25 miles per hour. The wind speed determination shall be based on either District forecasts or through use of an on-site anemometer as described in subdivision (g).
 - (2) Any person involved in active operations in the Coachella Valley Blowsand Zone shall stabilize new man-made deposits of bulk material within 24 hours of making such bulk material deposits. Stabilization procedures shall include one or more of the following:
 - (A) Application of water to at least 70 percent of the surface area of any bulk material deposits at least 3 times for each day that there is evidence of wind driven fugitive dust; or
 - (B) Application of chemical stabilizers in sufficient concentration so as to maintain a stabilized surface for a period of at least 6 months; or
 - (C) Installation of wind breaks of such design so as to reduce maximum wind gusts to less than 25 miles per hour in the area of the bulk material deposits.
 - (3) Any person involved in active operations in the Coachella Valley Blowsand Zone shall stabilize new deposits of bulk material originating from off-site undisturbed natural desert areas within 72 hours. Stabilization procedures shall include one or more of the following:
 - (A) Application of water to at least 70 percent of the surface area of any bulk material deposits at least 3 times for each day that there is evidence of wind driven fugitive dust; or
 - (B) Application of chemical stabilizers in sufficient concentration so as to maintain a stabilized surface for a period of at least six months.

- (4) A person who conducts or authorizes the conducting of an active operation shall implement at least one of the control actions specified in Rule 403, Table 2 for the source category "Inactive Disturbed Surface Areas" to minimize wind driven fugitive dust from disturbed surface areas at such time when active operations have ceased for a period of at least 20 days.
 - (5) Any person involved in agricultural tilling or soil mulching activities shall cease such activities when wind speeds exceed 25 miles per hour. The wind speed determination shall be based on either District forecasts or through use of an on-site anemometer as described in subdivision (g).
- (e) Fugitive Dust Control Plan and Other Requirements for Construction Projects/Earth-Moving Activities
- (1) Any person who conducts or authorizes the conducting of an active operation with a disturbed surface area of more than 5,000 square feet shall not initiate any earth-moving activities unless a fugitive dust control plan is prepared and approved by the Executive Officer in accordance with the requirements of subdivision (f) and the Rule 403.1 Implementation Handbook. These provisions shall not apply to active operations exempted by paragraph (i)(4).
 - (2) Any operator required to submit a fugitive dust control plan under paragraph (e)(1) shall maintain a complete copy of the approved fugitive dust control plan on site in a conspicuous place at all times and the fugitive dust control plan must be provided upon request.
 - (3) Any operator required to submit a fugitive dust control plan under paragraph (e)(1) shall install and maintain signage with project contact information that meets the minimum standards of the Rule 403.1 Implementation Handbook prior to initiating any type of earth-moving activities.
 - (4) Any operator required to submit a fugitive dust control plan under paragraph (e)(1) for a project with a disturbed surface area of 50 or more acres shall have an Dust Control Supervisor that:
 - (A) is employed by or contracted with the property owner or developer; and
 - (B) is on-site or is available to be on-site within 30 minutes of initial contact; and

- (C) has the authority to expeditiously employ sufficient dust mitigation measures to ensure compliance with all Rule 403 and 403.1 requirements; and
 - (D) has completed the AQMD Coachella Valley Fugitive Dust Control Class and has been issued a valid Certificate of Completion for the class.
- (5) Failure to comply with any of the provisions of an approved fugitive dust control plan shall be a violation of this rule.
- (f) Fugitive Dust Control Plan Preparation, Submittal, and Approval Requirements
- (1) A fugitive dust control plan prepared pursuant to paragraph (e)(1) must include the following information in a 8 ½ by 11 inch format:
 - (A) the name(s), address(es), and phone number(s) of the person(s) responsible for the preparation, submittal, and implementation of the fugitive dust control plan; and
 - (B) a description of the operation(s), including a map depicting the location of the site; and
 - (C) a listing of all sources of fugitive dust emissions within the property lines; and
 - (D) a description of the control measures as identified by the Rule 403.1 Implementation Handbook as applied to each of the sources identified in the fugitive dust control plan. The description of the control measures must be sufficiently detailed to demonstrate that the applicable best available control measures will be utilized and/or installed during all periods of active operations; and
 - (E) a description of the required contingency control measures (e.g., increased watering) for immediate implementation upon notice of visible dust crossing any property line.
 - (2) In the event that there are special technical (e.g., non-economic) circumstances, including safety, which prevent the use of at least one of the control measures as identified by the Rule 403.1 Implementation Handbook for any of the sources identified in the fugitive dust control plan, a justification statement must be provided in lieu of the description. The justification statement must explain the reason(s) why the required control measures cannot be implemented.
 - (3) Within 30 calendar days of the receipt of a fugitive dust control plan submitted pursuant to paragraph (e)(1), the Executive Officer will either

approve or apply any necessary conditions to the fugitive dust control plan in writing. For a fugitive dust control plan to be approved, the requirements of paragraph (f)(1) must be satisfied.

- (4) The Executive Officer will apply conditions if the stated fugitive dust control plan measures do not satisfactorily conform to the best available control measures and guidance contained in the Rule 403.1 Implementation Handbook. The conditions necessary to modify the fugitive dust control plan will be provided in writing to the person(s) identified in subparagraph (f)(1)(A). A letter to the Executive Officer stating that such modifications will be incorporated into the fugitive dust control plan shall be deemed sufficient to result in approval of the fugitive dust control plan.
- (5) Any fugitive dust control plan approved by the Executive Officer shall be valid for a period of one year from the date of approval. Any approved fugitive dust control plan must be resubmitted annually, at least 30 days prior to the expiration date, or the fugitive dust control plan shall expire as of the expiration date. If all fugitive dust sources and corresponding control measures or special circumstances remain identical to those identified in the previously approved fugitive dust control plan, the submittal may contain a simple statement of no-change (Form 403NC). Otherwise, a resubmittal must contain all the items specified in subparagraphs (f)(1)(A) through (f)(1)(E).

(g) Wind Monitoring Implementation Requirements

- (1) The determination of wind speed conditions in excess of 25 miles per hour, as specified in paragraphs (d)(1) and (d)(5), shall be based on the following criteria:
 - (A) For facilities with an on-site anemometer:
 - (i) When the on-site anemometer registers at least two wind gusts in excess of 25 miles per hour within a consecutive 30-minute period. Wind speeds shall be deemed to be below 25 miles per hour if there is no recurring wind gust in excess of 25 miles per hour within a consecutive 30-minute period; or
 - (B) For facilities without an on-site anemometer:

- (i) When wind speeds in excess of 25 miles per hour are forecast to occur in the Coachella Valley for that day. This condition shall apply to the full calendar day for which the forecast is valid. (The Executive Officer shall determine meteorological conditions which will cause wind speeds in excess of 25 miles per hour, and shall issue daily forecasts of expected wind conditions. Such forecasts shall be available to the public); or
 - (ii) When wind speeds in excess of 25 miles per hour are not forecast to occur by the District, and fugitive dust emissions are visible for a distance of at least 100 feet from the origin of such emissions, and there is visible evidence of wind driven fugitive dust.
- (2) Any person who elects to install an on-site anemometer shall:
 - (A) Notify the Executive Officer no more than 10 days after installing such equipment. The notification shall contain, at a minimum, the person's name, address, telephone number, description of the operation(s), and first day of operation, as specified in the District's Rule 403.1 Implementation Handbook.
 - (B) Be subject to the provisions of subparagraph (g)(1)(B) for wind speed determinations if equipment outages, malfunctions, or invalid data exceed one hour during active operations on a calendar day.
- (h) Recordkeeping
 - (1) A person subject to the provisions of this rule shall compile written daily records to document the specific actions taken to comply with this Rule. Such records shall be retained for not less than three years and shall be made available to the Executive Officer upon request.
 - (2) In addition to the provisions of paragraph (h)(1), any person who elects to install an on-site anemometer shall also compile written records. Such records shall contain:
 - (A) Location, vendor, model, and serial number of the anemometer;
 - (B) The time of occurrence of any wind gust in excess of 25 miles per hour during hours of active operations;

- (C) The actions taken to comply with the provisions of paragraphs (d)(5) and (i)(3), as applicable.
- (i) Exemptions
 - (1) The provisions of this rule shall not apply to ceased or inactive mining operations subject to the requirements of the Surface Mining and Recovery Act (SMARA) of 1975, provided that the provisions of the SMARA Reclamation Plan are implemented by the owner and are at least as stringent as those contained in this rule;
 - (2) The provisions of paragraphs (d)(2), (d)(3), and (d)(4) shall not apply to:
 - (A) Any active operation, open storage pile, or disturbed surface area for which necessary fugitive dust preventive or mitigative actions are in conflict with the Endangered Species Act as determined in writing by the State or federal agency responsible for making such determinations;
 - (B) Any disturbed surface areas or bulk material deposits with a surface area less than 2,500 square feet;
 - (C) Non-routine or emergency maintenance of flood control channels and water spreading basins.
 - (3) The provisions of paragraph (d)(5) shall not apply to agricultural tilling activities or soil mulching activities under the following conditions:
 - (A) If the prohibitory requirements of this Rule have occurred during six or more hours of active operations on each of two previous consecutive days, then a one-day exemption will be allowed. (These activities would again be subject to the prohibitory requirements of this Rule following this one day exemption.)
 - (B) If the prohibitory requirements of this Rule have occurred during sixty or more cumulative hours of active operations within a calendar month, then an exemption will be allowed for the remainder of the calendar month. (These activities would again be subject to the prohibitory requirements of this Rule at the start of the following month.)
 - (C) During periods of precipitation.

- (4) The provisions of paragraph (e)(1) shall not apply to any active operation which is required to submit a dust control plan to any city or county government that has adopted a District-approved dust control ordinance.

- (j) Fees
 - (1) Any person subject to a fugitive dust control plan submittal pursuant to paragraph (e)(1) shall be assessed applicable filing and evaluation fees pursuant to Rule 306.
 - (2) The submittal of an annual statement of no-change, pursuant to paragraph (f)(5), shall not be considered as an annual review, and therefore shall not be subject to annual review fees, pursuant to Rule 306.

APPENDIX "B"

PROJECT SIGN

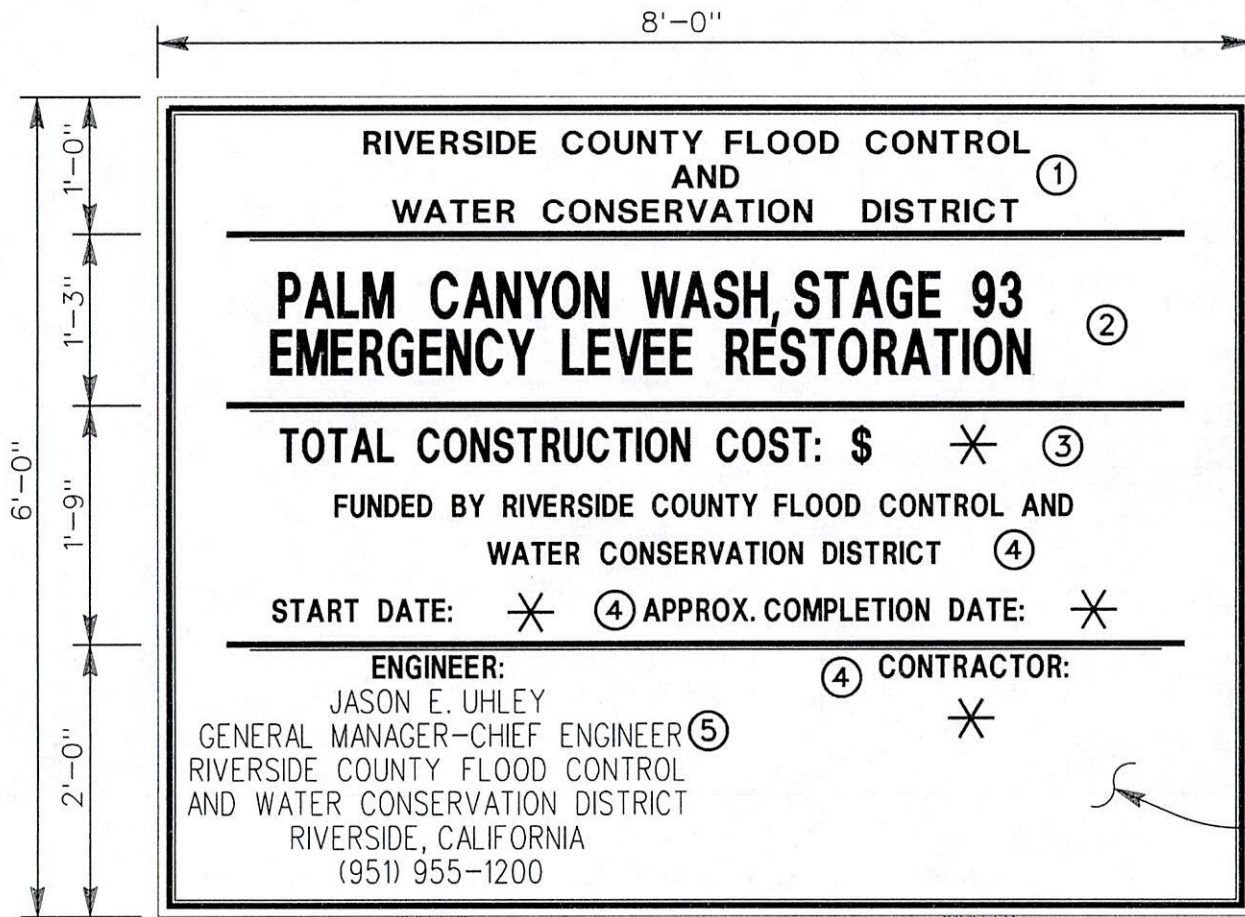

LETTER SCHEDULE

	<u>SIZE</u>	<u>COLOR</u>
①	2"	BLACK
②	4"	ROYAL
③	3"	ROYAL
④	2"	ROYAL
⑤	2"	BLACK

NOTES:

1. MINIMUM SPACING BETWEEN LINES 1".
2. * -INFO. FURNISHED BY ENGINEER
3. ALL LETTERS FILLED AND CENTERED
4. THE STRIPES ARE GOLD AND BLACK ON WHITE BACKGROUND.

APPENDIX "B" PROJECT SIGN

1000

1000

1000

1000

1000

1000

1000

1000

1000

1000

1000

1000

1000

1000

1000

1000

1000

1000

1000

APPENDIX "C"

LOG OF SOIL BORINGS GEOTECHNICAL REPORT

NOTICE: The geotechnical report is included herein for informational purposes only. This report was not prepared for purposes of bid development. It was produced to assist the design engineer regarding overall project feasibility and to make recommendations regarding some design parameters. Contractors are encouraged to confer with the geotechnical engineer who prepared the report (a modest fee may be required) and/or to conduct additional study to obtain the specific types of information they need or prefer.

**SUBMITTAL TO THE FLOOD CONTROL AND
WATER CONSERVATION DISTRICT
BOARD OF SUPERVISORS
COUNTY OF RIVERSIDE, STATE OF CALIFORNIA**



ITEM: 11.2
(ID # 13229)

MEETING DATE:
Tuesday, August 25, 2020

FROM: FLOOD CONTROL DISTRICT:

SUBJECT: FLOOD CONTROL DISTRICT: Approve Addenda to Plans and Specifications and Contract Documents; Accept Low Bid and Award the Contract for the Palm Canyon Wash, Stage 93 Emergency Levee Restoration, Project No. 6-0-00040-93, District 4. [\$1,932,839 - District Funds 100%]

RECOMMENDED MOTION: That the Board of Supervisors:

1. Approve the Addendum No. 1 to the Plans and Specifications and Contract Documents issued prior to the July 1, 2020 bid opening;
2. Waive any minor bid irregularities, and accept the low bid submitted by the firm of Sukut Construction, LLC for \$1,876,543 for the construction of the above-referenced project;
3. Award the Contract to Sukut Construction, LLC, and authorize the Chairwoman of the Board of Supervisors of the Riverside County Flood Control and Water Conservation District (District) to execute the Construction Agreement on behalf of the District; and
4. Direct the Clerk of the Board to return three (3) copies of the executed Palm Canyon Wash, Stage 93 Emergency Levee Restoration contract documents to the District.

ACTION: Policy

Jason Uhley, GENERAL MGR-CHF FLD CNTRL ENG 8/12/2020

MINUTES OF THE BOARD OF SUPERVISORS

On motion of Supervisor Spiegel, seconded by Supervisor Hewitt and duly carried, IT WAS ORDERED that the above matter is approved as recommended.

Ayes: Spiegel, Washington, Perez and Hewitt
Nays: None
Absent: Jeffries
Date: August 25, 2020
xc: Flood

Kecia R. Harper
Clerk of the Board

By:
Deputy

**SUBMITTAL TO THE FLOOD CONTROL AND WATER CONSERVATION DISTRICT BOARD
OF SUPERVISORS
COUNTY OF RIVERSIDE, STATE OF CALIFORNIA**

FINANCIAL DATA	Current Fiscal Year:	Next Fiscal Year:	Total Cost:	Ongoing Cost
COST	\$1,932,839	\$0	\$1,932,839	\$0
NET COUNTY COST	\$0	\$0	\$0	\$0
SOURCE OF FUNDS: 25160 947500 548200 Zone 6 Infrastructure (97%) 25160 947500 523220 Zone 6 License & Permits (3%)			Budget Adjustment: No	
			For Fiscal Year: 20/21	

C.E.O. RECOMMENDATION: Approve

BACKGROUND:

Summary

On May 19, 2020 (Agenda Item 11.4, MT#12418), the Board of Supervisors for the District authorized the Clerk of the Board to advertise for construction contract bids for the Palm Canyon Wash, Stage 93 Emergency Levee Restoration project.

The District opened bids for Palm Canyon Wash, Stage 93 Emergency Levee Restoration on July 1, 2020. Ten contractors submitted a bid in response to this call for bids. The lowest responsible bid was received from Sukut Construction, LLC for the sum of \$1,876,543. The bid documents have been reviewed by County Counsel and District staff. Two immaterial irregularities were noted on the bid bond, however, it was determined that the bid is valid and binding, and that the irregularities did not create an unfair advantage or directly affect the price of their bid. The bid was otherwise found to be responsive, and District staff recommends that the Board waive any minor irregularities found in the Contractor's bid.

On July 2, 2020, the second lowest bidder, Bosco Constructors, Inc., requested Sukut's bid documents and ultimately sent a letter on July 6, 2020 protesting Sukut's bid. The protest claimed that the execution of the bid documents was not valid and that the bid was unbalanced. The letter has been reviewed by District staff and Counsel, and both claims were determined to be unfounded.

On August 3, 2020, a Notice of Intent to Award the contract to Contractor was posted under Public Notices at rcflood.org. Pursuant to Article 3, Section 3.3 of the Instructions to Bidders, bidders are provided five days to submit any protest of the intent to award. No additional protests were received by the deadline.

The Contractor has executed the construction contract and provided the bonds and insurance documents, which meet the requirements of the contract.

The Fiscal Data listed includes this bid amount plus the required Coachella Valley Multiple Species Habitat Conservation Plan mitigation payment (see Additional Fiscal Information section below).

**SUBMITTAL TO THE FLOOD CONTROL AND WATER CONSERVATION DISTRICT BOARD
OF SUPERVISORS
COUNTY OF RIVERSIDE, STATE OF CALIFORNIA**

The Palm Canyon Wash Flood Control Facility is located in the southern portion of the city of Palm Springs. The emergency work consists of the repair and restoration of existing damaged levee sections in addition to necessary facility scour protection in the vicinity of Murray Canyon Drive and Toledo Avenue continuing approximately 800 feet downstream of Araby Drive. See Project Location Map.

County Counsel has reviewed the construction contract with exhibits and approved as to form.

CEQA Compliance

On May 19, 2020 (Agenda Item 11.4, MT#12418), the Board of Supervisors for the District found that the Palm Canyon Wash, Stage 93 Emergency Levee Restoration ("Project") is exempt from the California Environmental Quality Act (CEQA) pursuant to the State CEQA Guidelines Section 15269(a), (b), and (c) and that nothing further is required. In accordance with CEQA, a Notice of Exemption was prepared by the District and filed by the Clerk of the Board with the County Clerk.

Prev. Agn. Ref.: MT#12418 11.4 of 05/19/20 Advertise

Impact on Residents and Businesses

Impact on local residents and businesses during construction is considered to be minimal. Residents and businesses could experience general construction noise or dust from heavy equipment.

This emergency work will restore and enhance critical sections of the levee and ensure continued flood protection to adjacent communities during future storm events. The project will repair and restore damaged levee sections resulting from the attack of concentrated flows at the existing levee face. Included in this work is additional scour protection to restore the original design intent by deepening levee panels or providing extensions in areas deemed insufficient.

Additional Fiscal Information

Pursuant to the Implementing Agreement for the Coachella Valley Multiple Species Habitat Conservation Plan (MSHCP) executed on October 30, 2007, the Financial Data listed is comprised of the bid amount of \$1,876,543 for Contractor, plus up to \$56,296 (3% of bid) for MSHCP mitigation, for a total of \$1,932,839 (bid plus 3% amount). The MSHCP Implementing Agreement requires the District to make a payment to the Coachella Valley Conservation Commission for up to 3% of the total capital costs (bid amount described above) as required mitigation for the construction of flood control facilities. The actual mitigation payment that will be made by the District may be reduced based on acquisition of replacement habitat for the benefit of Covered Species, as defined in the Implementing Agreement and the MSHCP.

Contract History and Price Reasonableness

**SUBMITTAL TO THE FLOOD CONTROL AND WATER CONSERVATION DISTRICT BOARD
OF SUPERVISORS
COUNTY OF RIVERSIDE, STATE OF CALIFORNIA**

Pursuant to Public Contract Code 21091, invitation of sealed bids was solicited by advertising in print and digital media. The Contractor's bid was reasonable and is approximately 34% below the project engineer's estimate.

ATTACHMENTS:

1. Addendum No. 1
2. Bid Summary/Abstract
3. Protest Letter and Response
4. Project Location Map
5. Contract Documents (Sheets XXIII through XXXIV) and Certificate of Liability Insurance - 4 copies



Jason Farin, Principal Management Analyst 8/17/2020



Gregory F. Priamos, Director County Counsel 8/13/2020

Plot Date: 06/05/09 - 1:35pm, Plotted by: kim.le
Drawing Path: Y:\13203\000\0\acard\ Drawing Name: Palm Canyon Wash Levees_site_loc_map_lb.dwg

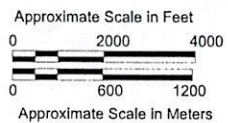
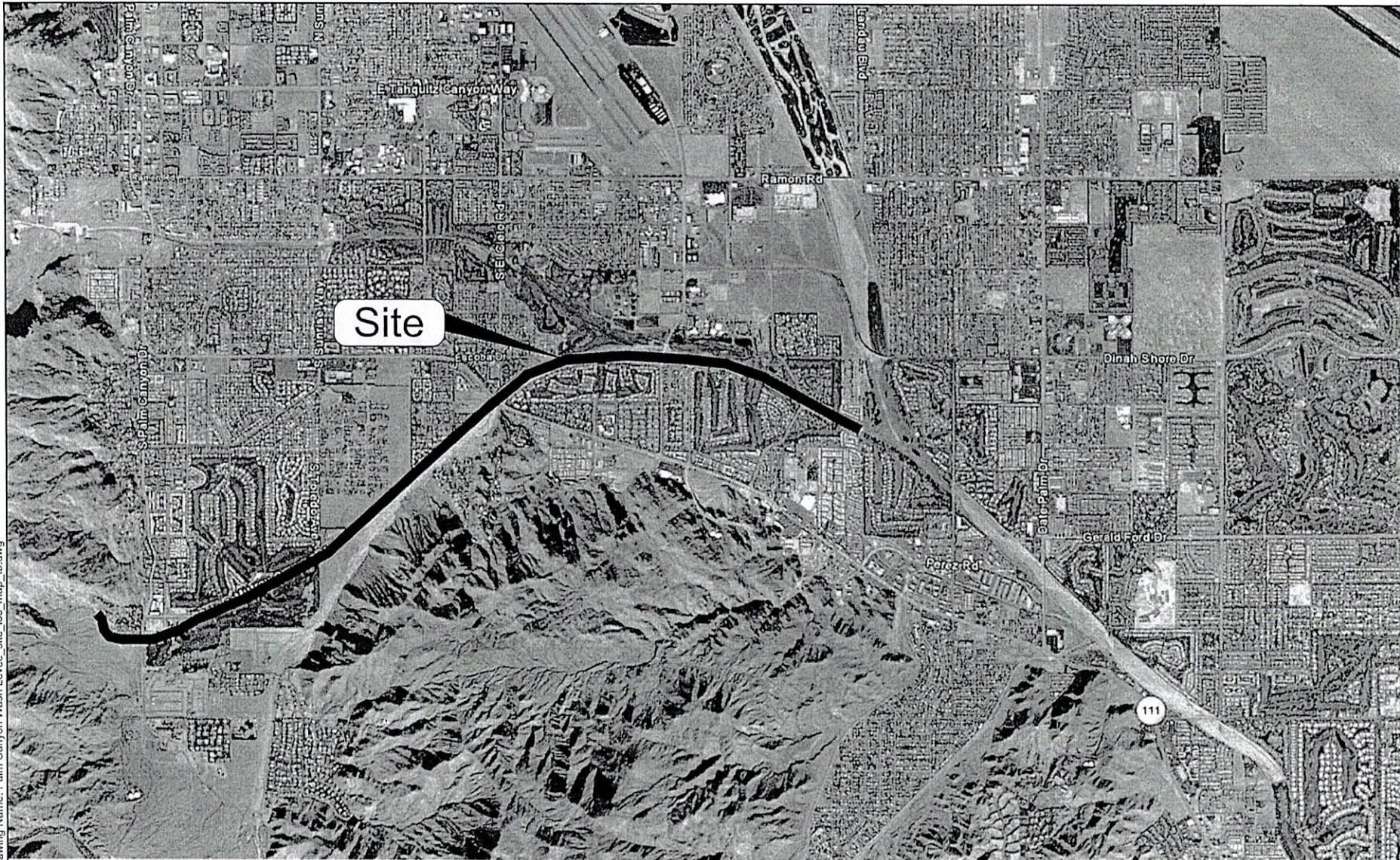

Basemap modified from Google Earth,
aerial photograph dated 2006

SITE LOCATION MAP
Palm Canyon Wash Levees
FEMA Levee Certification
Palm Springs, California

By: kle	Date: 6/4/09	Project No. 13203
---------	--------------	-------------------

AMEC Geomatrix

Figure 1

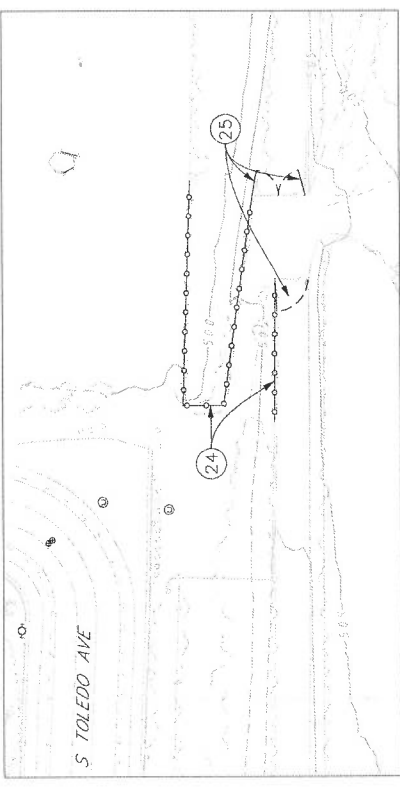
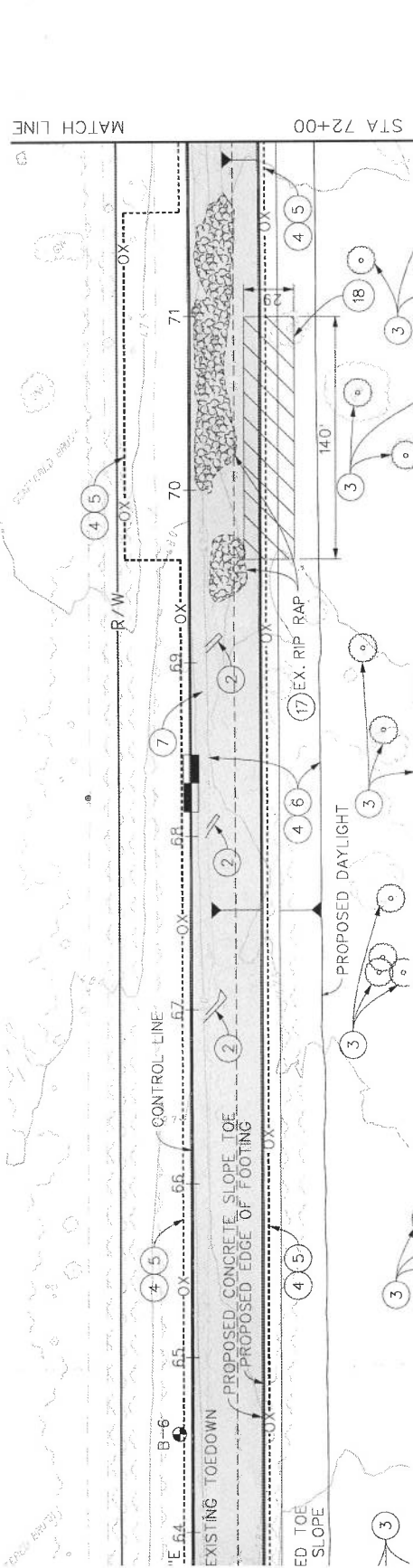
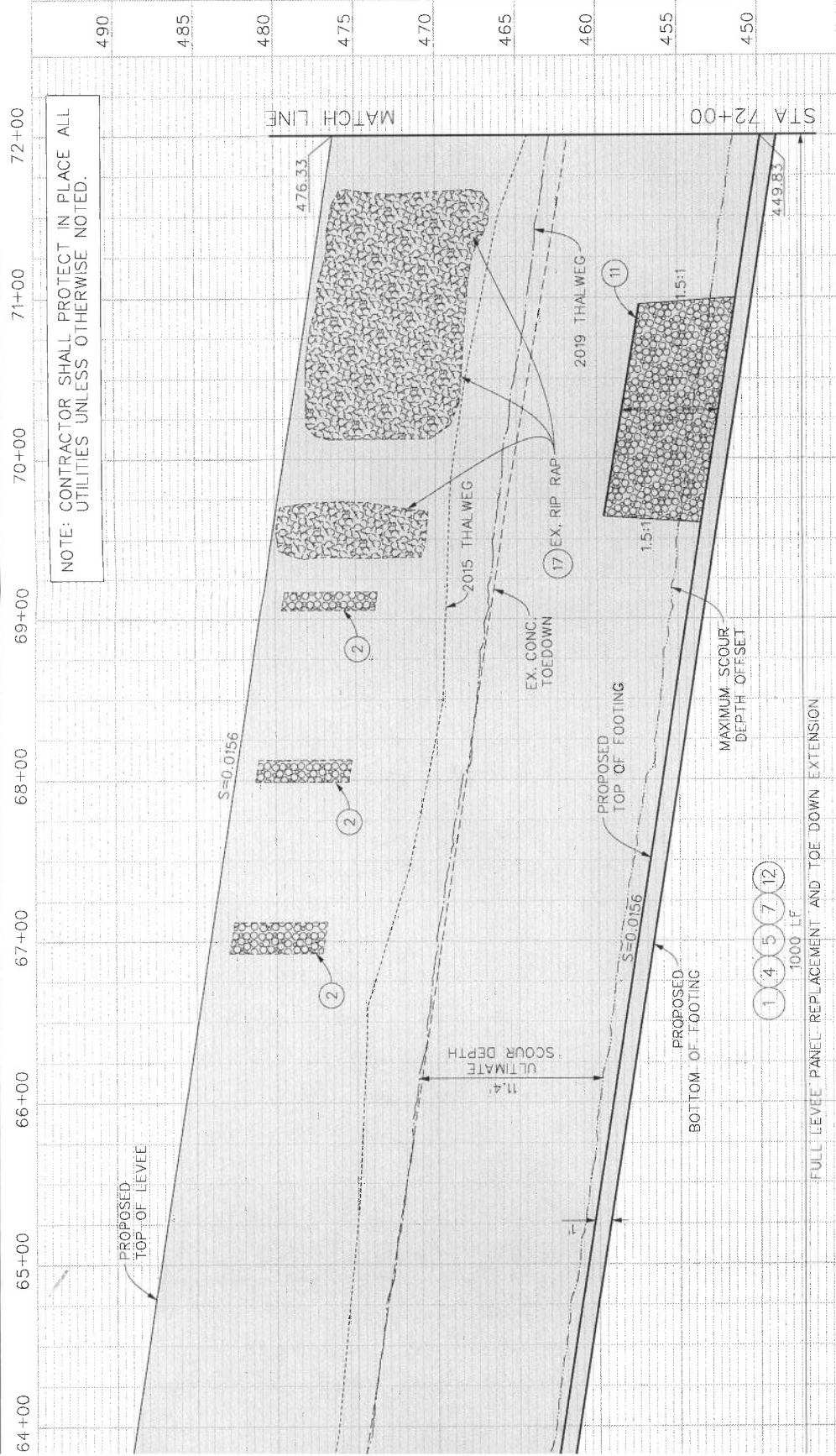

DETAIL A

FOR TYPICAL SECTION SEE SHEET 8.

NOTES

- 1 BREAK, REMOVE EXISTING APPROX. 4" THICK UNREINFORCED CONCRETE PANELS AND TEMPORARILY STOCKPILE FOR LATER USE AS DIRECTED BY THE ENGINEER AND SHOWN ON THE DRAWINGS.
- 2 REMOVE EXISTING STEEL MEMBERS AND GABION BASKET WIRES, DISPOSE LEGALLY OFFSITE, TEMPORARILY STOCKPILE ALL GABION ROCKS FOR LATER USE AS DIRECTED BY THE ENGINEER AND AS SHOWN ON THE DRAWINGS.
- 3 PROTECT NATIVE TREE SPECIES PER SPECIFICATIONS AND AS SHOWN ON THE DRAWINGS.
- 4 EXCAVATE AND OVEREXCAVATE PER PAYLINE LIMITS SHOWN ON SHEETS 8-10.
- 5 EMBANKMENT PER PAYLINE LIMITS SHOWN ON SHEETS 8-10.
- 6 BACKFILL PER PAYLINE LIMITS SHOWN ON SHEETS 8-10.
- 7 CONSTRUCT FULL CONCRETE SLOPE PAVING PANELING PER DETAIL E ON SHEET 11.
- 9 AREA DESIGNATED FOR CONTRACTOR INGRESS AND EGRESS.
- 10 CONSTRUCT PERIMETER DEMARCATION FENCING WITH 5' OPENINGS EVERY 50' INTERVAL, ANY DISTURBANCE BEYOND SUCH LIMITS IS STRICTLY PROHIBITED.
- 11 CONSTRUCT 4' CUTOFF WALL PER DETAIL A&C ON SHEET 12.
- 12 CONSTRUCT 2' CUT OFF WALL PER DETAIL E ON SHEET 11.
- 17 REMOVE EXISTING RIP-RAP AND TEMPORARILY STOCKPILE FOR LATER USE AS DIRECTED BY THE ENGINEER AND SHOWN ON THE DRAWINGS.
- 18 BACKFILL STOCKPILED CONCRETE RUBBLE, GABION ROCKS, AND RIP-RAP 6' HIGH WITH 1.5:1 SLOPES AS DIRECTED BY THE ENGINEER AND SHOWN ON THE DRAWINGS.
- 24 REMOVE AND REINSTALL FENCE AS NECESSARY AND DIRECTED BY THE ENGINEER.
- 25 REMOVE AND REINSTALL GATE AS NECESSARY AND DIRECTED BY THE ENGINEER.

LEGEND

- TREE TO BE AVOIDED, IF FEASIBLE
- OX--- OVEREXCAVATION LIMITS
- ▭ IMPRFS/FRP/FFCS APFA

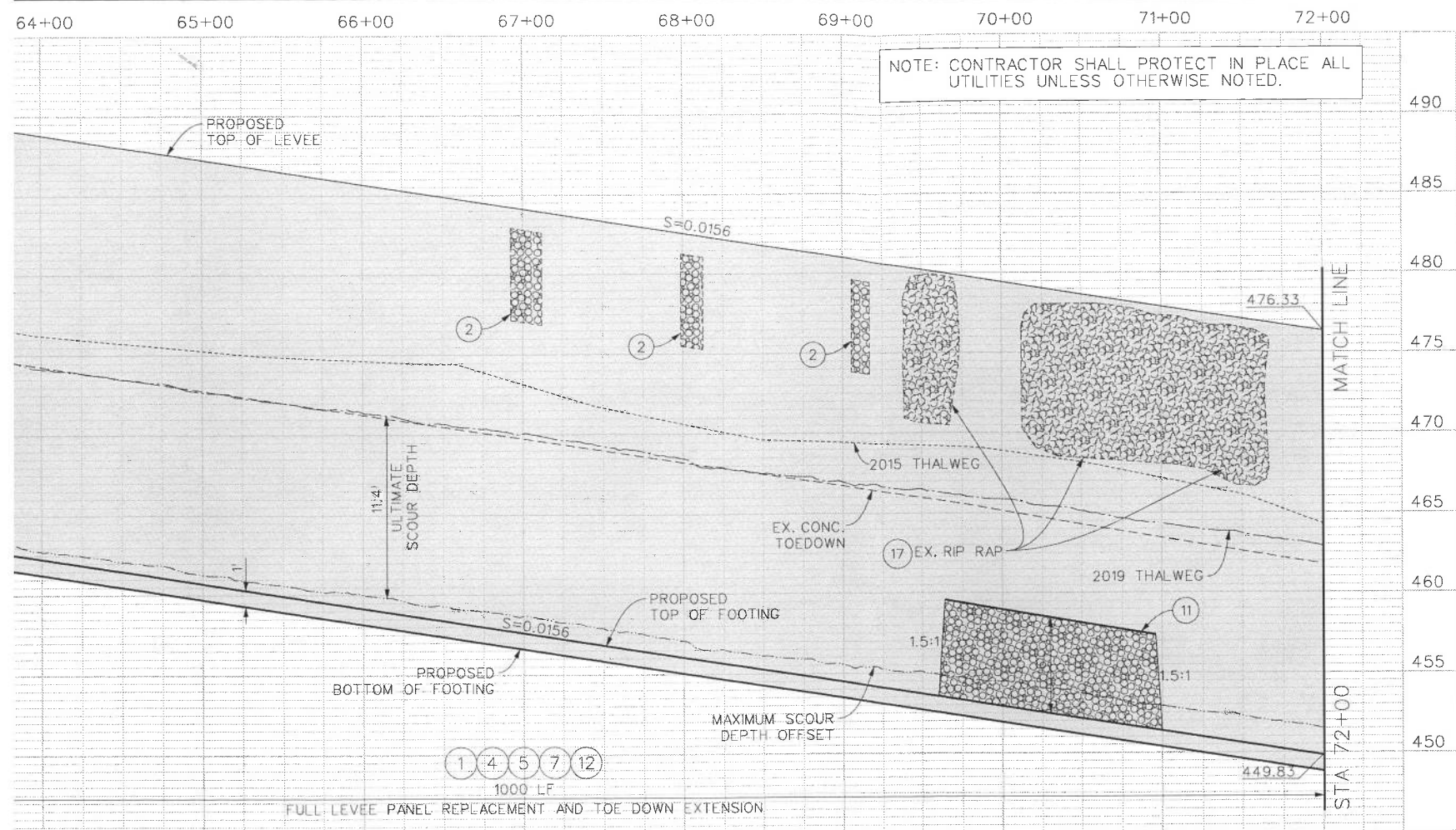

PROFILE

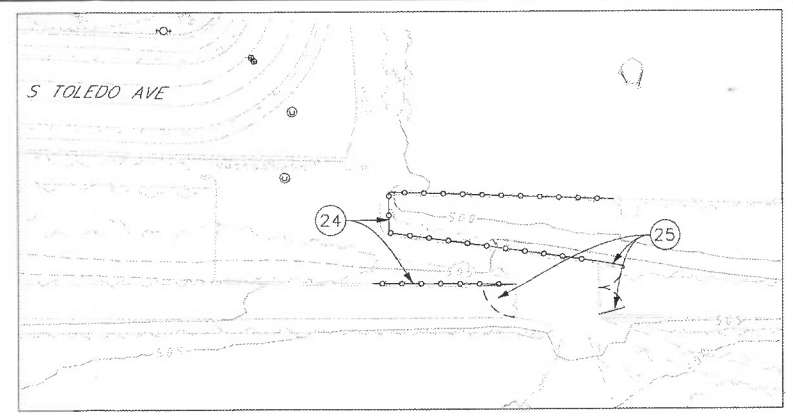

DETAIL A

FOR TYPICAL SECTION SEE SHEET 8

NOTES

- 1) BREAK, REMOVE EXISTING APPROX. 4" THICK UNREINFORCED CONCRETE PANELS AND TEMPORARILY STOCKPILE FOR LATER USE AS DIRECTED BY THE ENGINEER AND SHOWN ON THE DRAWINGS.
- 2) REMOVE EXISTING STEEL MEMBERS AND GABION BASKET WIRES, DISPOSE LEGALLY OFFSITE, TEMPORARILY STOCKPILE ALL GABION ROCKS FOR LATER USE AS DIRECTED BY THE ENGINEER AND AS SHOWN ON THE DRAWINGS.
- 3) PROTECT NATIVE TREE SPECIES PER SPECIFICATIONS AND AS SHOWN ON THE DRAWINGS.
- 4) EXCAVATE AND OVEREXCAVATE PER PAYLINE LIMITS SHOWN ON SHEETS 8-10.
- 5) EMBANKMENT PER PAYLINE LIMITS SHOWN ON SHEETS 8-10.
- 6) BACKFILL PER PAYLINE LIMITS SHOWN ON SHEETS 8-10.
- 7) CONSTRUCT FULL CONCRETE SLOPE PAVING PANELING PER DETAIL E ON SHEET 11.
- 9) AREA DESIGNATED FOR CONTRACTOR INGRESS AND EGRESS.
- 10) CONSTRUCT PERIMETER DEMARCATION FENCING WITH 5' OPENINGS EVERY 50' INTERVAL, ANY DISTURBANCE BEYOND SUCH LIMITS IS STRICTLY PROHIBITED.
- 11) CONSTRUCT 4' CUTOFF WALL PER DETAIL A&C ON SHEET 12.
- 12) CONSTRUCT 2' CUT OFF WALL PER DETAIL E ON SHEET 11.
- 17) REMOVE EXISTING RIP-RAP AND TEMPORARILY STOCKPILE FOR LATER USE AS DIRECTED BY THE ENGINEER AND SHOWN ON THE DRAWINGS.
- 18) BACKFILL STOCKPILED CONCRETE RUBBLE, GABION ROCKS, AND RIP-RAP 6' HEIGHT WITH 1.5:1 SLOPES AS DIRECTED BY THE ENGINEER AND SHOWN ON THE DRAWINGS.
- 24) REMOVE AND REINSTALL FENCE AS NECESSARY AND DIRECTED BY THE ENGINEER.
- 25) REMOVE AND REINSTALL GATE AS NECESSARY AND DIRECTED BY THE ENGINEER.

LEGEND

- TREE TO BE AVOIDED, IF FEASIBLE
- OVEREXCAVATION LIMITS
- INGRESS/EGRESS AREA

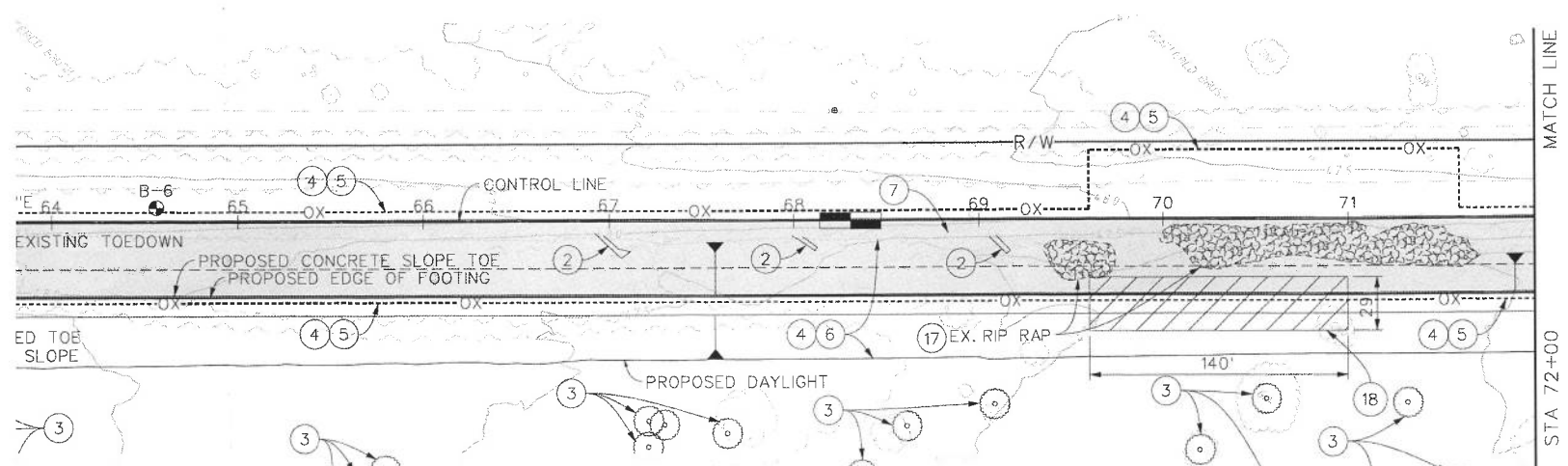

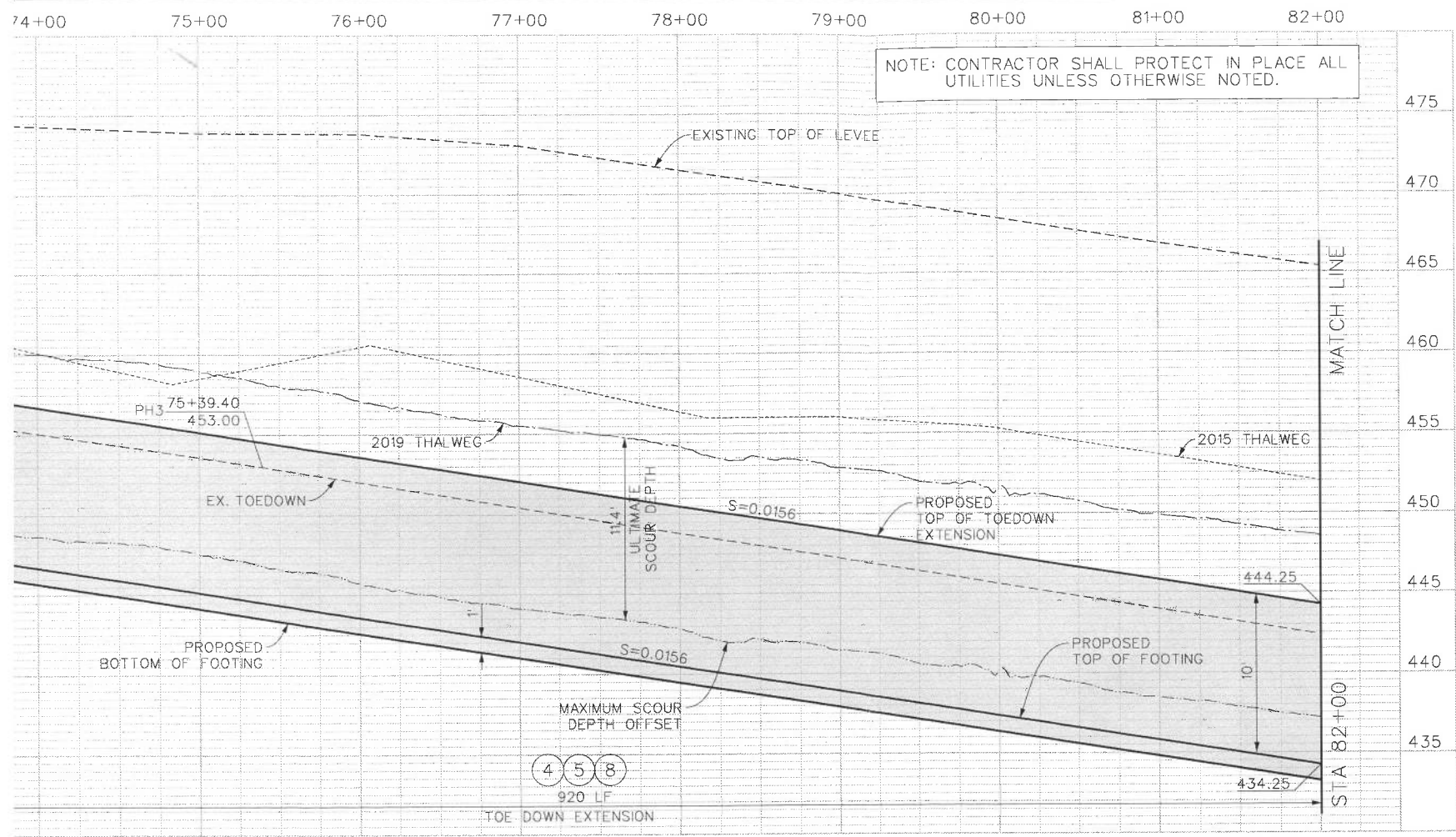

PROFILE

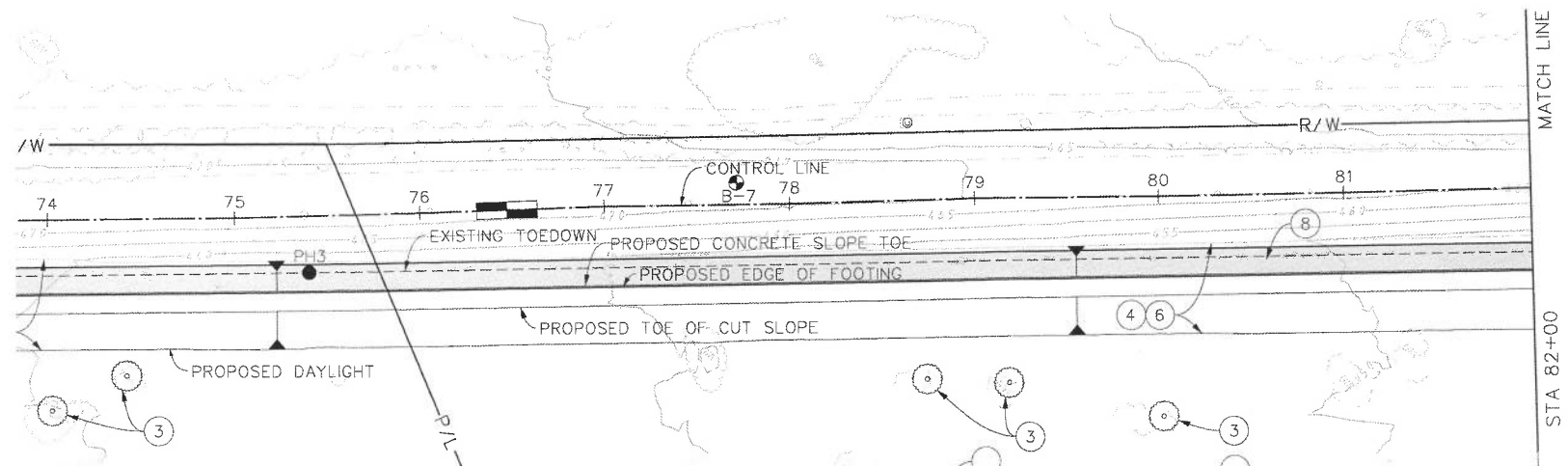

NOTE: CONTRACTOR SHALL PROTECT IN PLACE ALL UTILITIES UNLESS OTHERWISE NOTED.

PH#	STA	NORTHING	EASTING	GROUND ELEVATION	TOEDOWN ELEVATION
PH1	72+76.45	2230943.90	6478924.64	462.74	460.55
PH2	72+79.12	2230941.90	6478929.98	462.68	456.90
PH3	75+39.40	2231117.08	6479123.44	457.16	453.00

FOR TYPICAL SECTION SEE SHEET 9

NOTES

- 1 BREAK, REMOVE EXISTING APPROX. 4" THICK UNREINFORCED CONCRETE PANELS AND TEMPORARILY STOCKPILE FOR LATER USE AS DIRECTED BY THE ENGINEER AND SHOWN ON THE DRAWINGS.
- 3 PROTECT NATIVE TREE SPECIES PER SPECIFICATIONS AND AS SHOWN ON THE DRAWINGS.
- 4 EXCAVATE AND OVEREXCAVATE PER PAYLINE LIMITS SHOWN ON SHEETS 8-10.
- 5 EMBANKMENT PER PAYLINE LIMITS SHOWN ON SHEETS 8-10.
- 6 BACKFILL PER PAYLINE LIMITS SHOWN ON SHEETS 8-10.
- 7 CONSTRUCT FULL CONCRETE SLOPE PAVING PANELING PER DETAIL E ON SHEET 11.
- 8 CONSTRUCT TOEDOWN CONCRETE SLOPE PAVING PANELING EXTENSION PER DETAIL F ON SHEET 11.
- 10 CONSTRUCT PERIMETER DEMARCATION FENCING WITH 5' OPENINGS EVERY 50' INTERVAL, ANY DISTURBANCE BEYOND SUCH LIMITS IS STRICTLY PROHIBITED.
- 12 CONSTRUCT 2' CUT OFF WALL PER DETAIL E ON SHEET 11.
- 13 SEE FULL LEVEE PANEL TO TOEDOWN EXTENSION TRANSITION DETAIL ON SHEET 12.

LEGEND

- TREE TO BE AVOIDED, IF FEASIBLE
- OX-- OVEREXCAVATION LIMITS

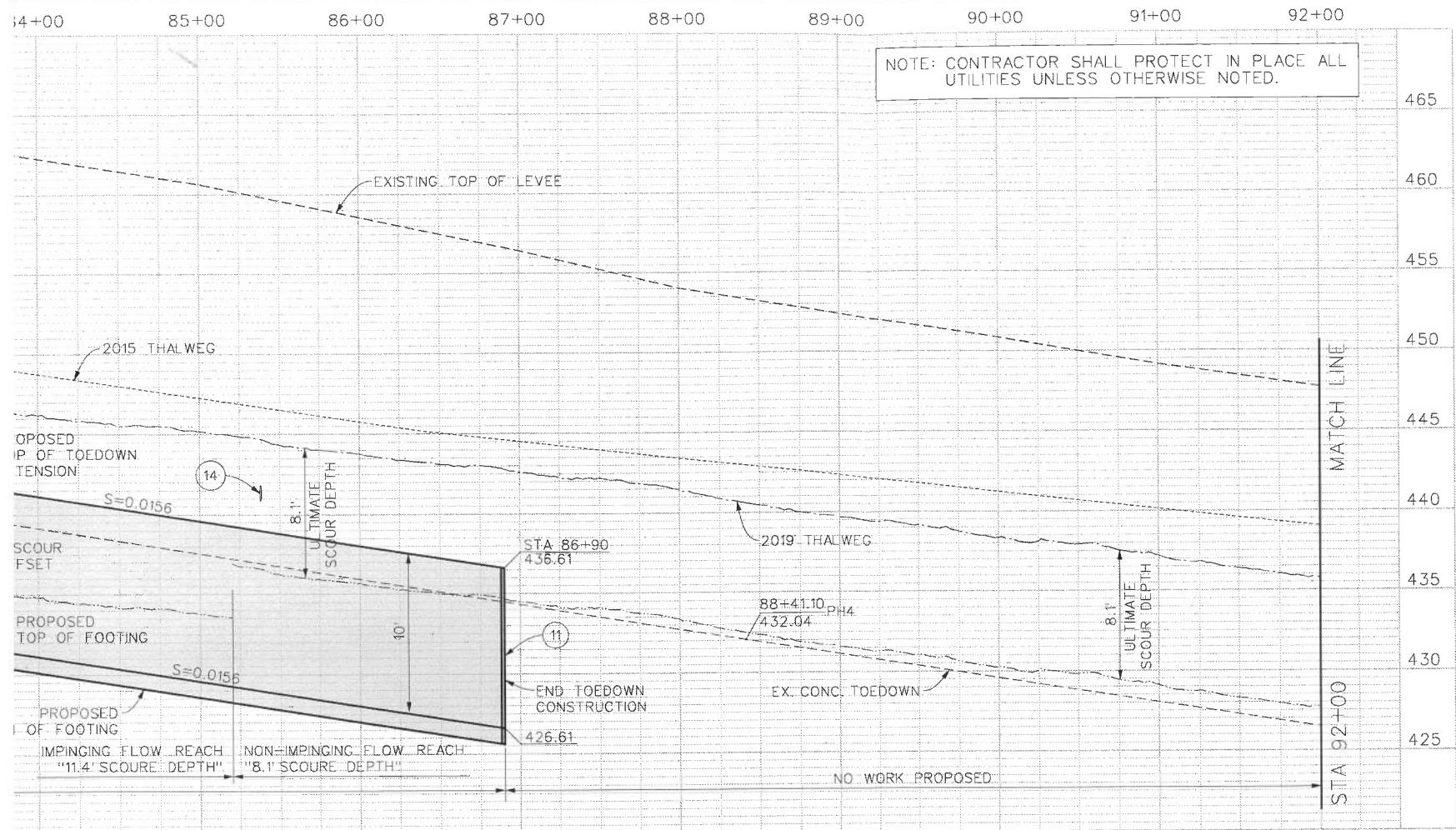

NOTE: CONTRACTOR SHALL PROTECT IN PLACE ALL UTILITIES UNLESS OTHERWISE NOTED.

PH#	STA	NORTHING	EASTING	GROUND ELEVATION	TOEDOWN ELEVATION
PH4	88+41.10	2231993.28	6480085.57	440.86	432.04

FOR TYPICAL SECTION SEE SHEET 9

PROFILE

- NOTES**
- PROTECT NATIVE TREE SPECIES PER SPECIFICATIONS AND AS SHOWN ON THE DRAWINGS.
 - EXCAVATE AND OVEREXCAVATE PER PAYLINE LIMITS SHOWN ON SHEETS 8-10.
 - EMBANKMENT PER PAYLINE LIMITS SHOWN ON SHEETS 8-10.
 - BACKFILL PER PAYLINE LIMITS SHOWN ON SHEETS 8-10.
 - CONSTRUCT TOEDOWN CONCRETE SLOPE PAVING PANELING EXTENSION PER DETAIL F ON SHEET 11.
 - CONSTRUCT PERIMETER DEMARCATION FENCING WITH 5' OPENINGS EVERY 50' INTERVAL, ANY DISTURBANCE BEYOND SUCH LIMITS IS STRICTLY PROHIBITED.
 - CONSTRUCT 4' CUTOFF WALL PER DETAIL A&C ON SHEET 12.
 - EXISTING 12" STEEL OUTLET PIPE (DESERT WATER AGENCY) TO BE PROTECTED IN PLACE AND IS SUBJECT TO WATER DISCHARGE BY DWA AT ANY TIME.

LEGEND

- TREE TO BE AVOIDED, IF FEASIBLE
- OVEREXCAVATION LIMITS

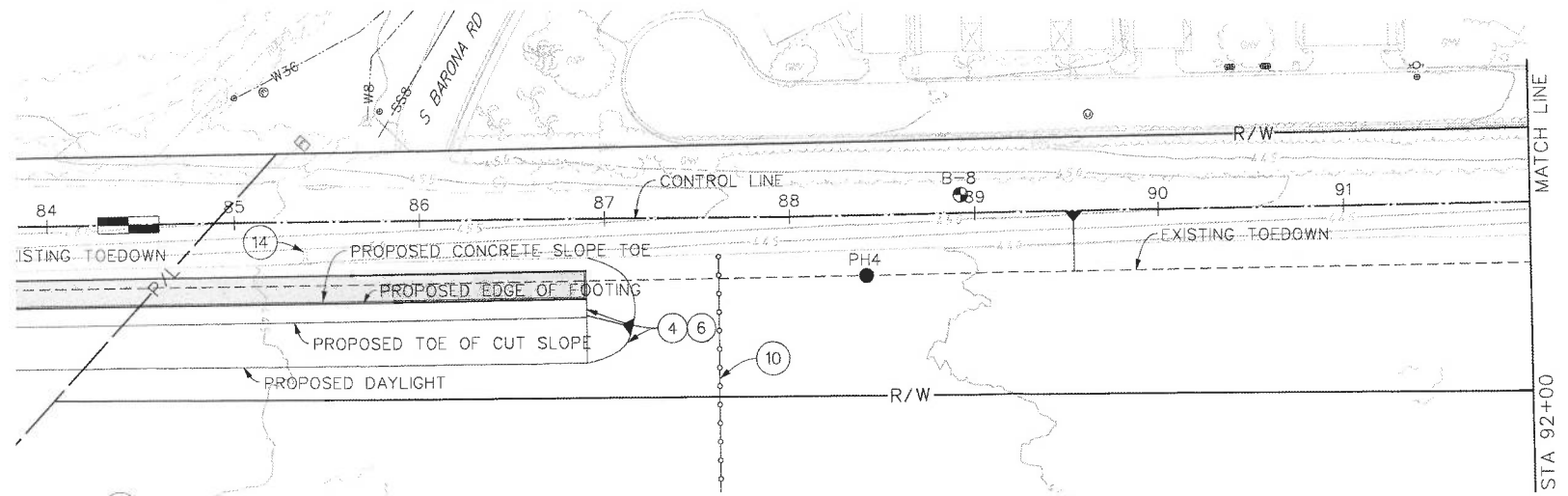

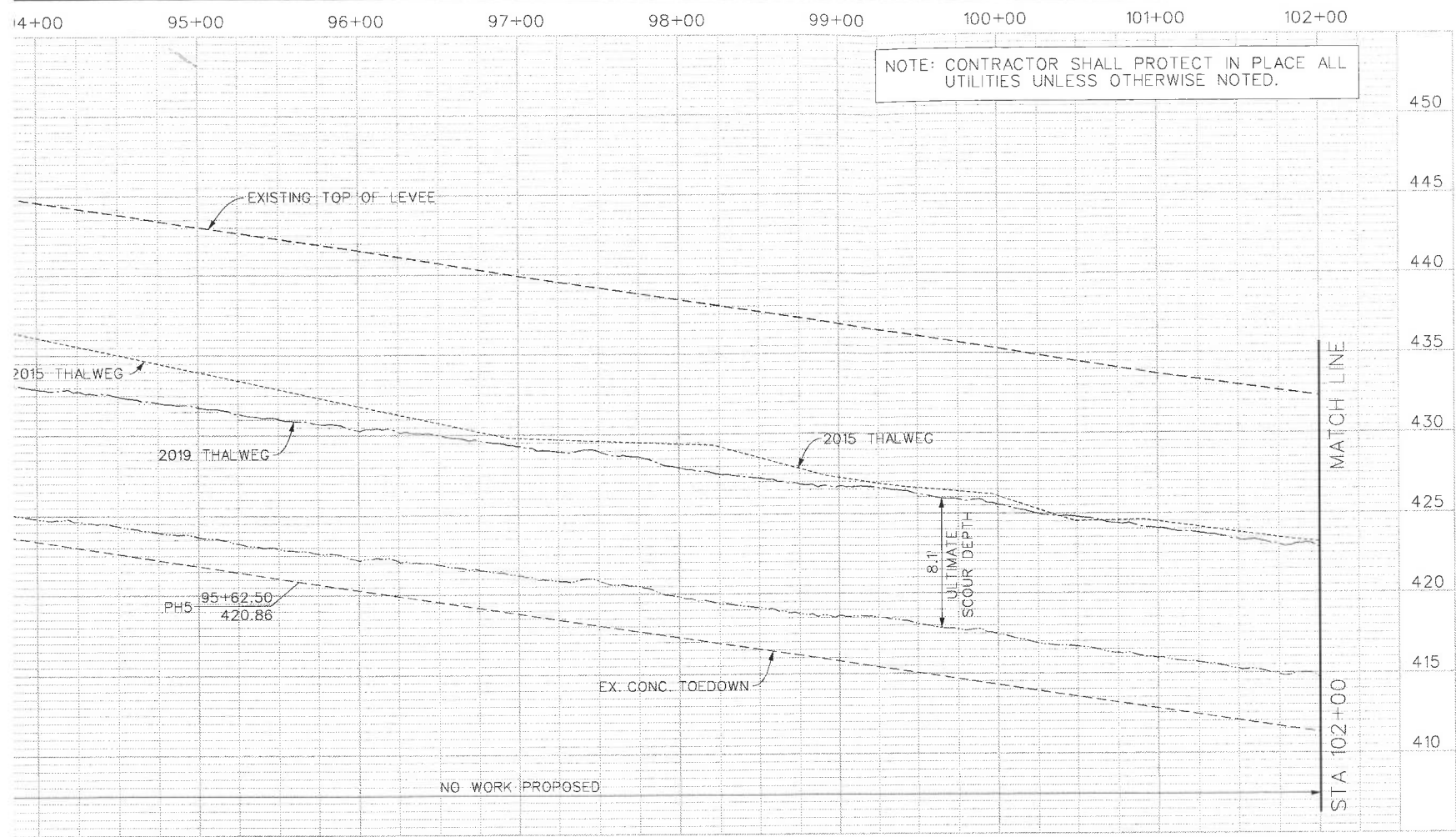

PH#	STA	NORTHING	EASTING	GROUND ELEVATION	TOEDOWN ELEVATION
PH5	95+62.50	2232479.72	6480618.31	431.08	420.86

PROFILE

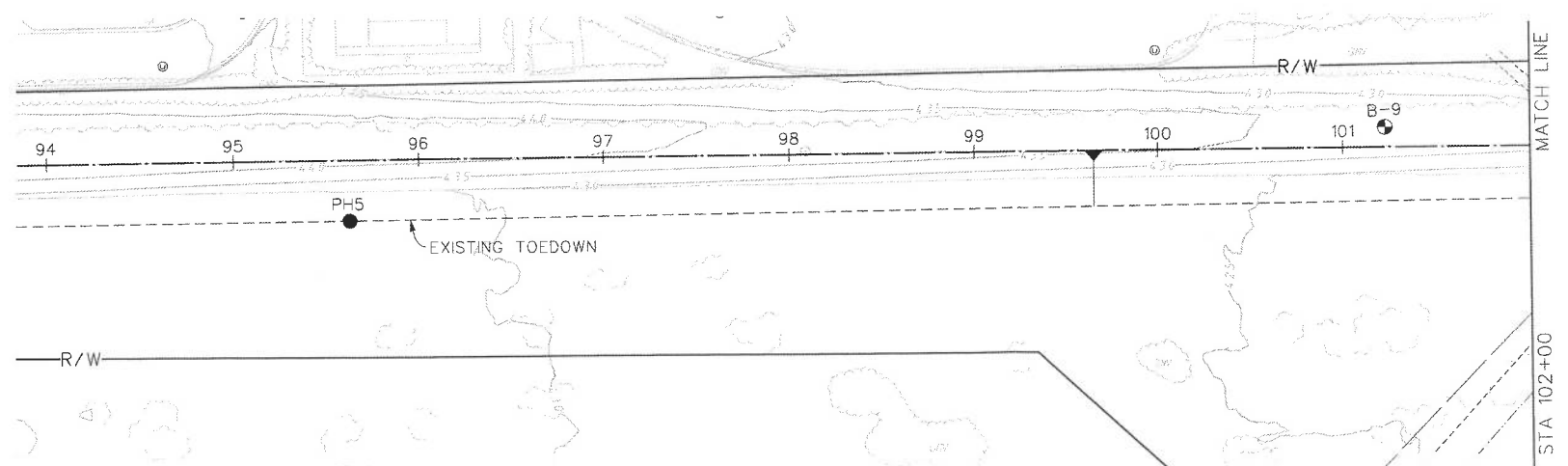

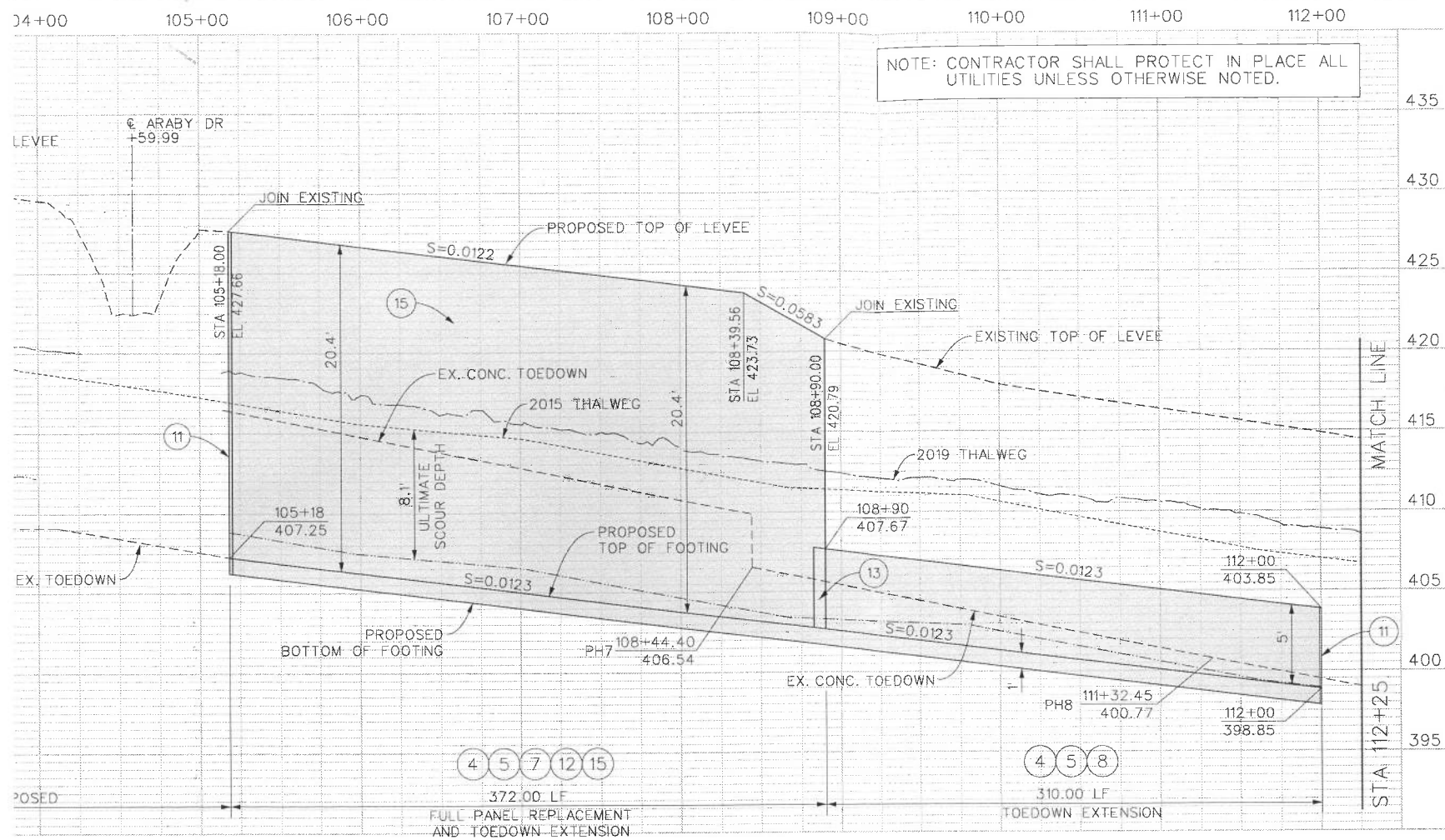

PH#	STA	NORTHING	EASTING	GROUND ELEVATION	TOEDOWN ELEVATION
PH6	103+44.86	2233008.60	6481196.91	420.69	409.09
PH7	108+44.40	2233364.92	6481547.71	413.20	406.54
PH8	111+32.45	2233574.82	6481744.49	410.12	400.77

FOR TYPICAL SECTION SEE SHEET 10

PROFILE

- NOTES**
- 3 PROTECT NATIVE TREE SPECIES PER SPECIFICATIONS AND AS SHOWN ON THE DRAWINGS.
 - 4 EXCAVATE AND OVEREXCAVATE PER PAYLINE LIMITS SHOWN ON SHEETS 8-10.
 - 5 EMBANKMENT PER PAYLINE LIMITS SHOWN ON SHEETS 8-10.
 - 6 BACKFILL PER PAYLINE LIMITS SHOWN ON SHEETS 8-10.
 - 7 CONSTRUCT FULL CONCRETE SLOPE PAVING PANELING PER DETAIL E ON SHEET 11.
 - 8 CONSTRUCT TOEDOWN CONCRETE SLOPE PAVING PANELING EXTENSION PER DETAIL F ON SHEET 11.
 - 10 CONSTRUCT PERIMETER DEMARCATION FENCING WITH 5' OPENINGS EVERY 50' INTERVAL, ANY DISTURBANCE BEYOND SUCH LIMITS IS STRICTLY PROHIBITED.
 - 11 CONSTRUCT 4' CUTOFF WALL PER DETAIL A&C ON SHEET 12.
 - 12 CONSTRUCT 2' CUT OFF WALL PER DETAIL E ON SHEET 11.
 - 13 SEE FULL LEVEE PANEL TO TOEDOWN EXTENSION TRANSITION DETAIL ON SHEET 12.
 - 15 BREAK, REMOVE EXISTING APPROX. 2" THICK CONCRETE RIP-RAP AND TEMPORARILY STOCKPILE FOR LATER USE AS DIRECTED BY THE ENGINEER AND SHOWN ON THE DRAWINGS.

LEGEND

- TREE TO BE AVOIDED, IF FEASIBLE
- OVEREXCAVATION LIMITS

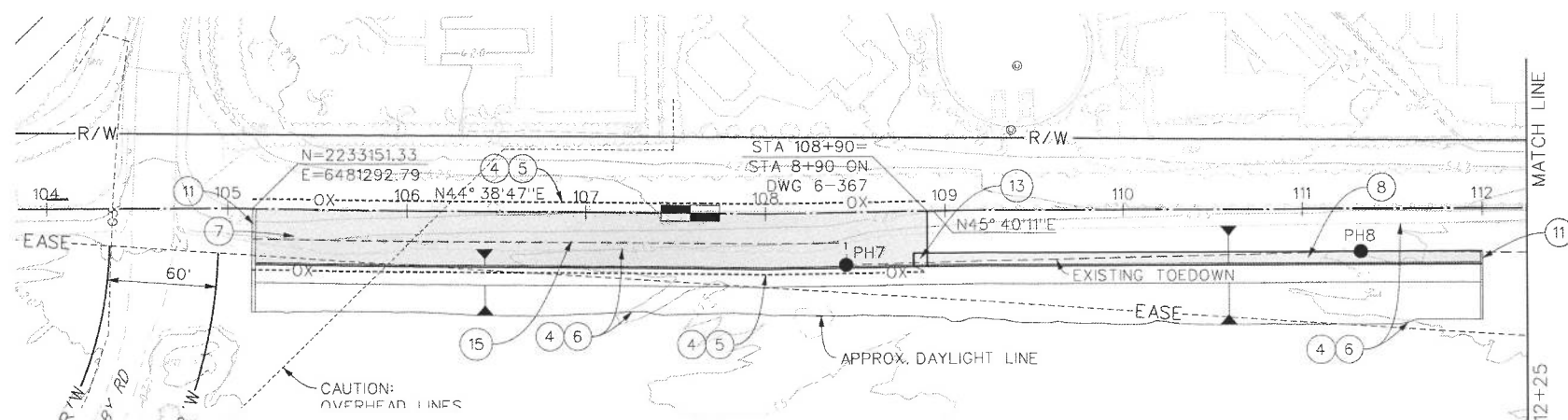

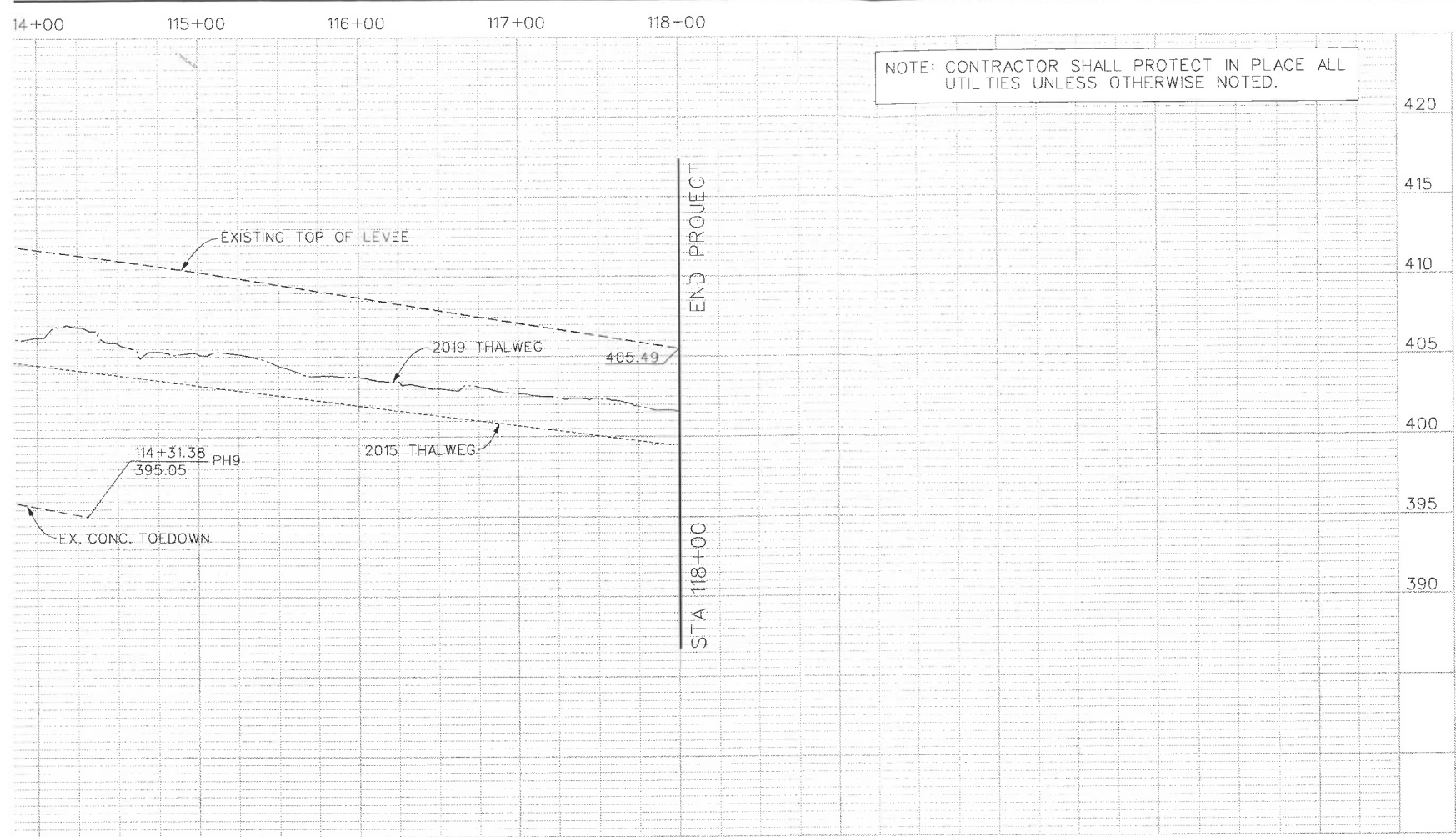



PH#	STA	NORTHING	EASTING	GROUND ELEVATION	TOEDOWN ELEVATION
PH9	114+31.38	2233786.40	6481955.64	406.27	395.05

- NOTES**
- 3 PROTECT NATIVE TREE SPECIES PER SPECIFICATIONS AND AS SHOWN ON THE DRAWINGS.
 - 4 EXCAVATE AND OVEREXCAVATE PER PAYLINE LIMITS SHOWN ON SHEETS 8-10.
 - 5 EMBANKMENT PER PAYLINE LIMITS SHOWN ON SHEETS 8-10.
 - 6 BACKFILL PER PAYLINE LIMITS SHOWN ON SHEETS 8-10.
 - 8 CONSTRUCT TOEDOWN CONCRETE SLOPE PAVING PANELING EXTENSION PER DETAIL F ON SHEET 11.
 - 10 CONSTRUCT PERIMETER DEMARCATION FENCING WITH 5' OPENINGS EVERY 50' INTERVAL, ANY DISTURBANCE BEYOND SUCH LIMITS IS STRICTLY PROHIBITED.

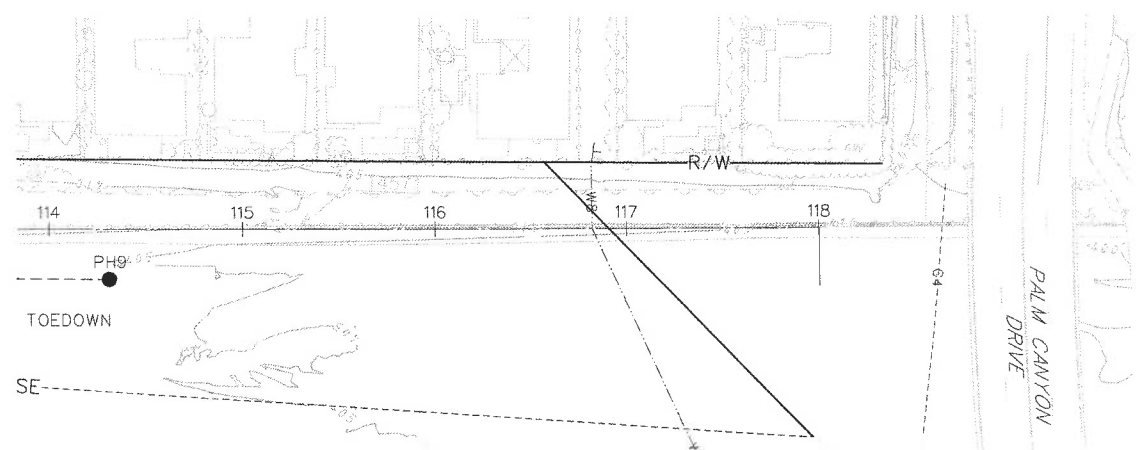
PROFILE



LEGEND

-  TREE TO BE AVOIDED, IF FEASIBLE

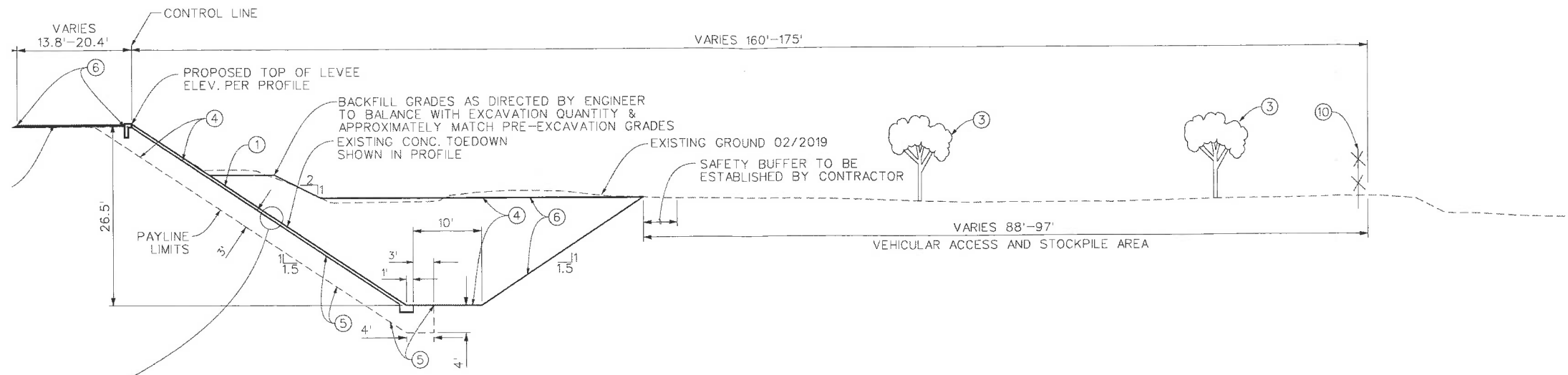

STA. 62+00 TO STA. 69+60
 STA. 71+60 TO STA. 72+80

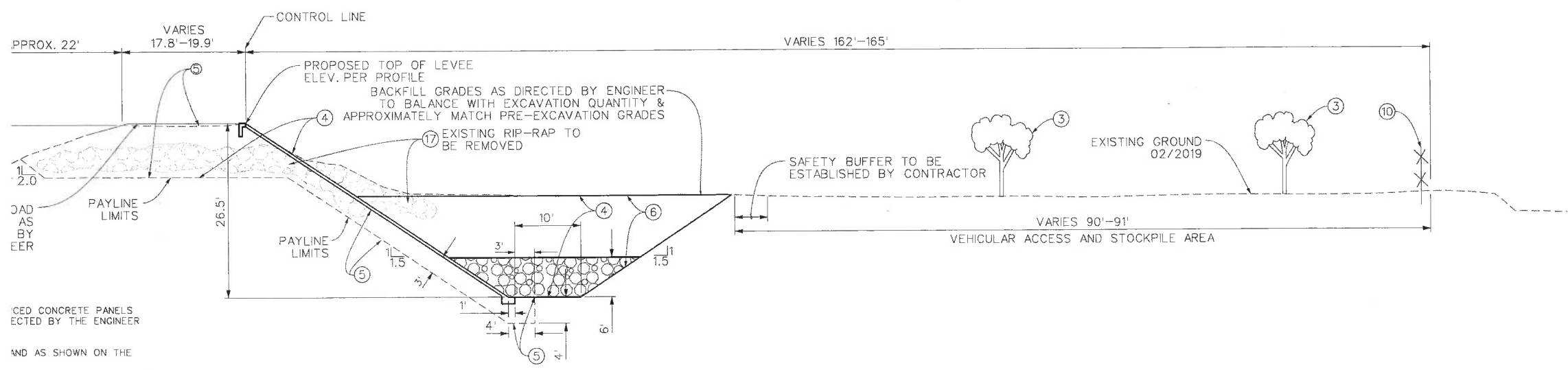

CAST CONCRETE PANELS
 AS DIRECTED BY THE ENGINEER
 AND AS SHOWN ON THE

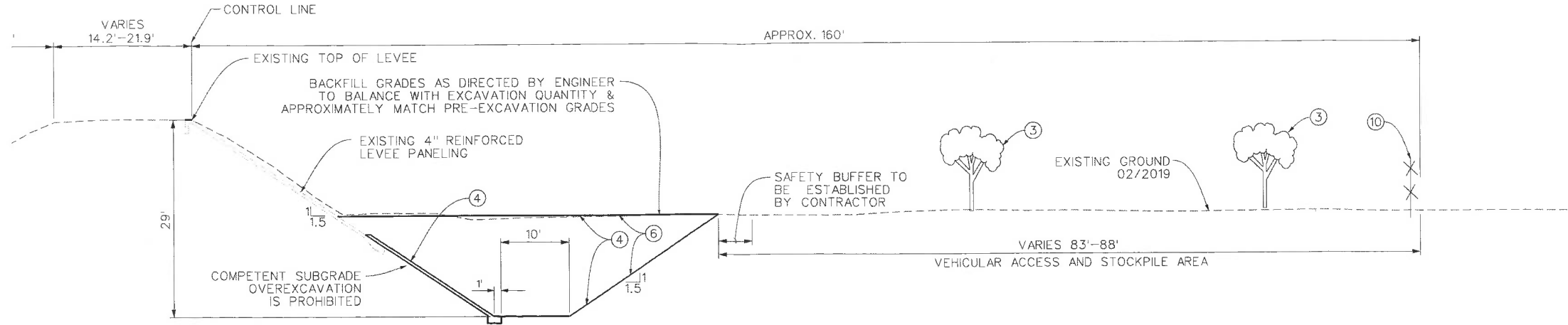

STA. 72+80 TO STA. 86+90

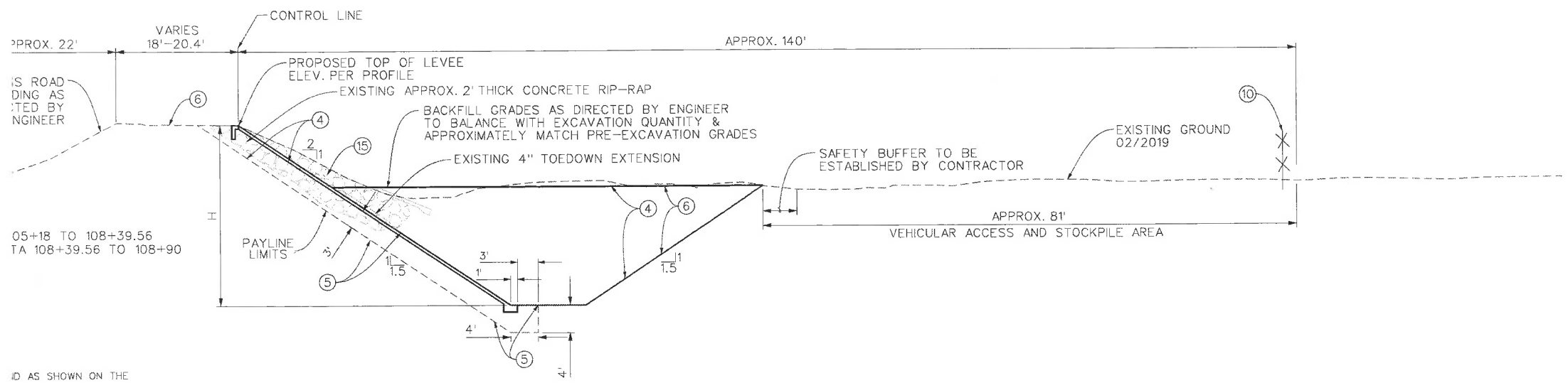

STA. 105+18 TO STA. 108+00

IS ROAD
ING AS
TED BY
GINEER

05+18 TO 108+39.56
TA 108+39.56 TO 108+90

AS SHOWN ON THE
OWN HEREON.

OPENINGS EVERY
3 STRICTLY PROHIBITED.

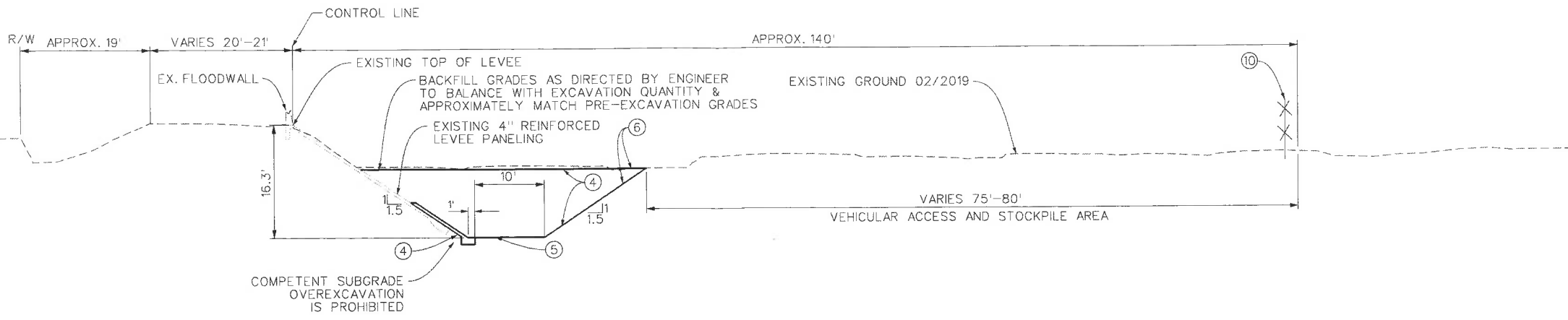

STA. 108+90 TO STA. 112+00

WN HEREON.
OPENINGS EVERY
STRICTLY PROHIBITED.

UCTION DRAWING SET DATED APRIL 23, 2020

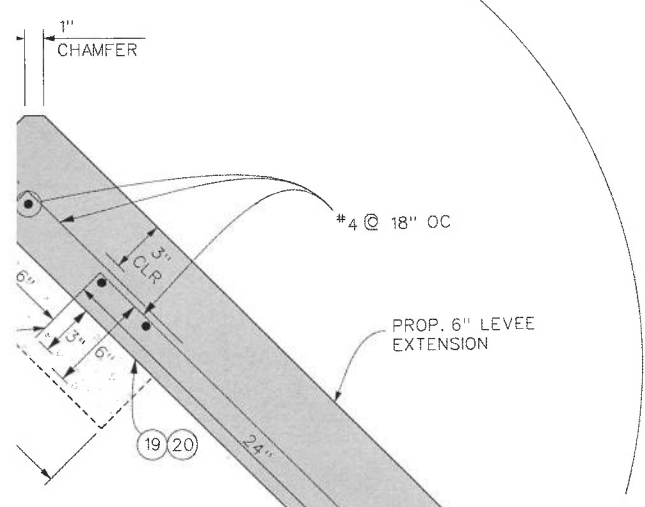
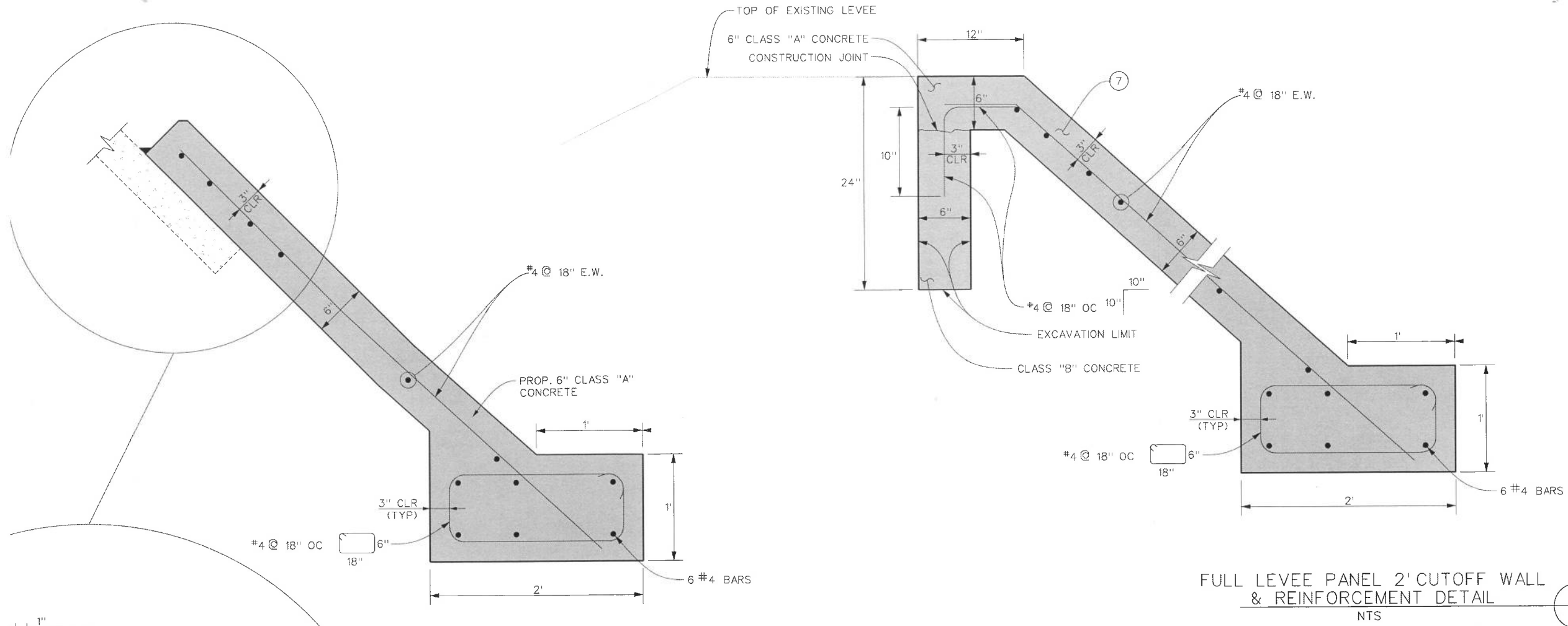

- NOTES**
- (7) CONSTRUCT FULL CONCRETE SLOPE PAVING PANELING PER DETAIL E ON SHEET 11.
 - (19) REMOVE ALL ROCK, CONCRETE, DERIS AND VEGETATION PRIOR TO CONSTRUCTION OF NEW 6" PANELING.
 - (20) PROTECT EXISTING LEVEE PANEL IN PLACE, AIR BLAST SURFACE OF EXISTING PANELING TO CLEAN AND REMOVE ALL LOOSE PARTICLE/DEBRIS PRIOR TO CONSTRUCTION OF NEW 6" PANELING.
 - (21) PLACE EXPOXY ALONG ENTIRE EDGE OF LEVEE PANEL.
 - (23) DOWEL INTO EXISTING PANELING A MINIMUM OF 3" AND EPOXY CONNECTION. SPACING TO BE 18" OC AND STAGGERED IN THE TRANSVERSE DIRECTION AS SHOWN HFRFON AND AS DIRECTED BY THE ENGINEER.

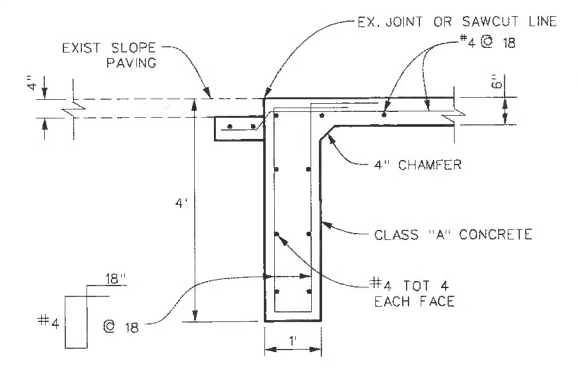
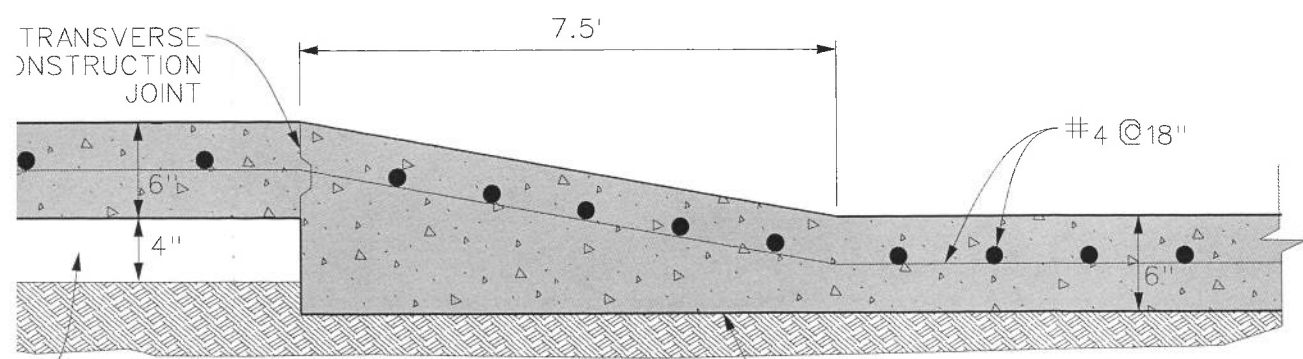
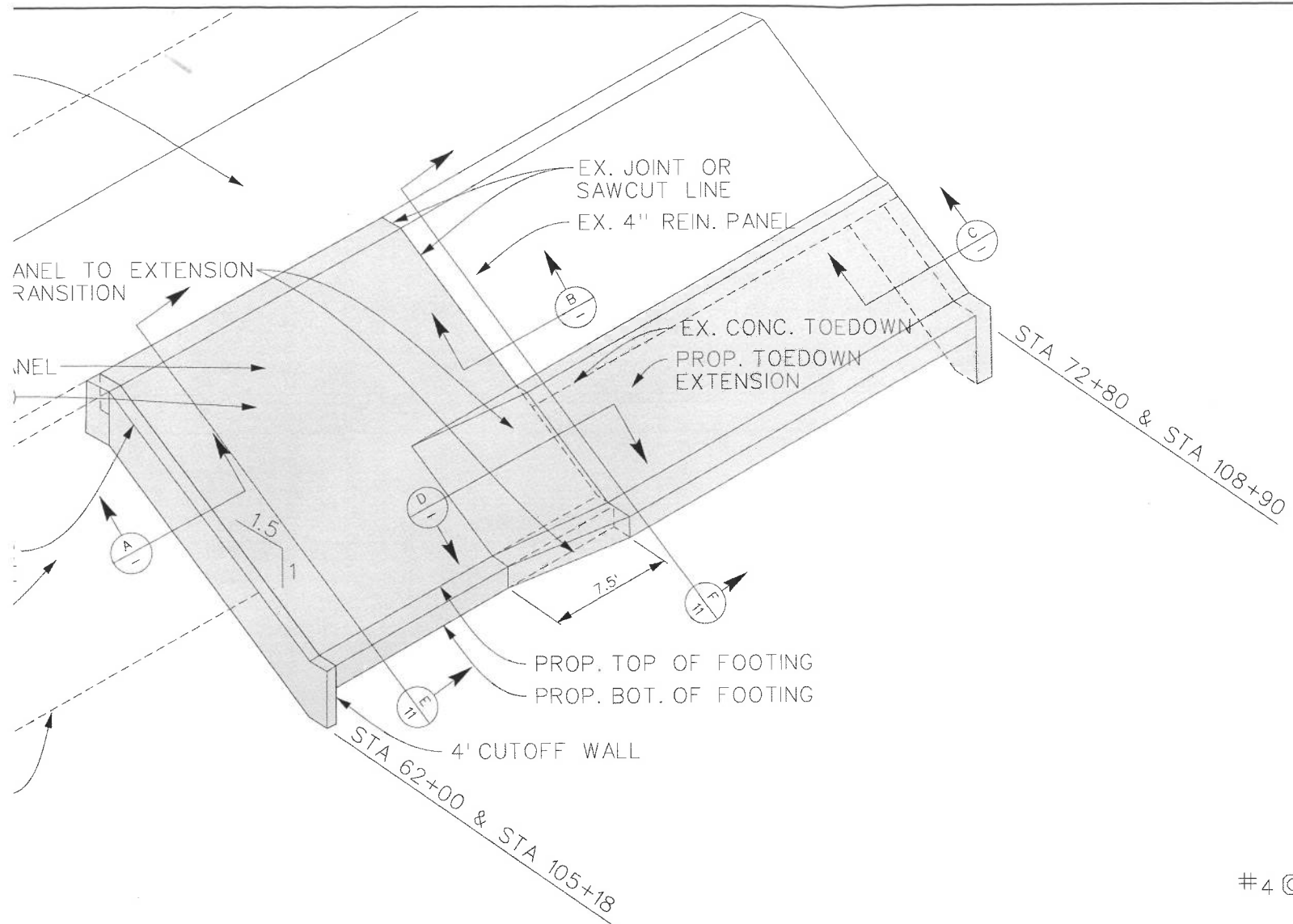

END CUT-OFF WALL DETAIL (A-X)
NTS

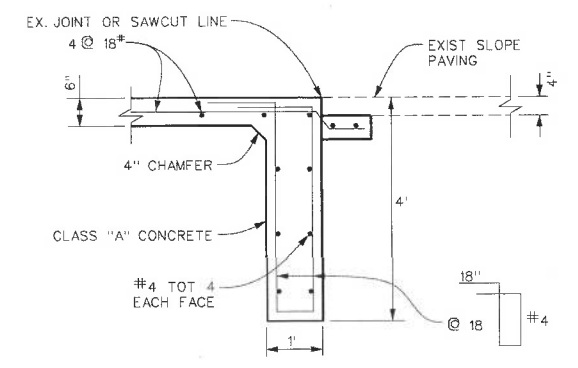

END CUT-OFF WALL DETAIL (C-X)
NTS

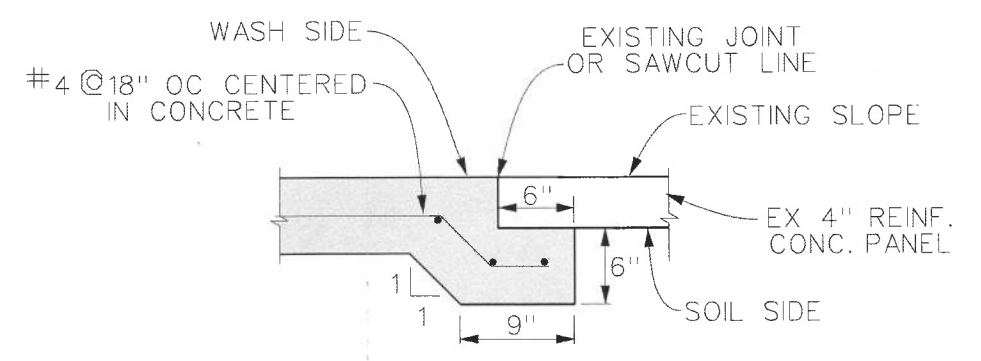

JOINT CONNECTION DETAIL (B-)
(NEW PANEL CONSTRUCTION TO EXISTING PANEL)
NTS