

**SUBMITTAL TO THE BOARD OF SUPERVISORS  
COUNTY OF RIVERSIDE, STATE OF CALIFORNIA**



**ITEM: 3.25  
(ID # 20748)**

**MEETING DATE:**  
Tuesday, January 31, 2023

**FROM :** TLMA-TRANSPORTATION:

**SUBJECT:** TRANSPORTATION AND LAND MANAGEMENT AGENCY/TRANSPORTATION:  
Adoption of Ordinance No. 461.11, Amending Riverside County Ordinance No. 461 Relating to the County Road Standards and County Standard Specifications. CEQA Exempt Per State CEQA Guidelines Section 15061(b)(3). All Districts. [\$0]

**RECOMMENDED MOTION:** That the Board of Supervisors:

1. Adopt Ordinance No. 461.11, an Ordinance of the County of Riverside amending Ordinance No. 461 in its entirety relating to County Road Standards and County Standard Specifications;
2. Direct the Clerk of the Board to publish the summary of the ordinance within 15 days after adoption of the ordinance pursuant to California Government Code Section 25124(b); and
3. Direct the Clerk of the Board to file and post the attached Notice of Exemption with the County Clerk within five (5) days after the adoption of Ordinance No. 461.11 and in accordance with the California Environmental Quality Act, Public Resources Code section 21152.

**ACTION:Policy**

  
Mark Lancaster, Director of Transportation 1/19/2023

---

**MINUTES OF THE BOARD OF SUPERVISORS**

On motion of Supervisor Washington, seconded by Supervisor Gutierrez and duly carried by unanimous vote, IT WAS ORDERED that the above matter is approved as recommended and Ordinance 461.11 is adopted with waiver of the reading.

Ayes: Jeffries, Spiegel, Washington, Perez and Gutierrez  
Nays: None  
Absent: None  
Date: January 31, 2023  
xc: Transp., Recorders

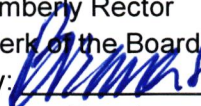
Kimberly Rector  
Clerk of the Board  
By:   
Deputy

**SUBMITTAL TO THE BOARD OF SUPERVISORS COUNTY OF RIVERSIDE,  
STATE OF CALIFORNIA**

<b>FINANCIAL DATA</b>	<b>Current Fiscal Year:</b>	<b>Next Fiscal Year:</b>	<b>Total Cost:</b>	<b>Ongoing Cost</b>
<b>COST</b>	\$ 0	\$ 0	\$ 0	\$ 0
<b>NET COUNTY COST</b>	\$ 0	\$ 0	\$ 0	\$ 0
<b>SOURCE OF FUNDS:</b> There are no General Funds used on this project.			<b>Budget Adjustment:</b> No	
			<b>For Fiscal Year:</b> N/A	

**C.E.O. RECOMMENDATION:** Approve

**BACKGROUND:**

**Summary**

Ordinance No. 461 establishes County Road Standards and County Standard Specifications (Standards) used for the design, construction, and inspection of public roadways in the unincorporated areas of the County of Riverside.

The Standards were last comprehensively updated and adopted by the Board of Supervisors fifteen years ago at its regular meeting on November 20, 2007, agenda item 3.50, under Ordinance No. 461.10.

The Transportation Department comprehensively updated the Standards to ensure compliance with current state and federal regulations, reflect advancements in technology, implement public safety improvements, and clarify local requirements for the County road system. A summary of the updates is included in Appendix A of the County Road Standards and County Standard Specifications.

County Counsel has approved Ordinance No. 461.11 as to form.

**Previous Agenda References**

December 13, 2022 – Initiation of Amendment to Ordinance No. 461 (Agenda Item 3.46)

January 24, 2023 – Introduction of Ordinance No. 461.11 (Agenda Item 3.45)

**CEQA**

The Board of Supervisors found on January 24, 2023, Agenda Item 3.45, Ordinance No. 461.11 exempt from CEQA pursuant to State CEQA Guidelines section 15061(b)(3). A Notice of Exemption for Ordinance No. 461.11 is attached.

Ordinance No. 461.11 will become effective 30 days from the date of adoption.

**Impact on Residents and Businesses**

The updates included in Ordinance No. 461.11 County Road Standards and County Standard Specifications clarify technical requirements, comply with the latest state and federal

**SUBMITTAL TO THE BOARD OF SUPERVISORS COUNTY OF RIVERSIDE,  
STATE OF CALIFORNIA**

regulations, improve traffic safety, improve access for persons with disabilities, improve water quality, utilize latest technologies, reduce energy consumption, reduce road maintenance costs, and prolong the service life of the County road system.

**Additional Fiscal Information**

N/A

**Contract History and Price Reasonableness**

N/A

**ATTACHMENTS:**

Ordinance No. 461.11

Exhibit A - County Road Standards and County Standard Specifications

Appendix A - Summary of Updates

CEQA Notice of Exemption / Journal Voucher



Jason Farin, Principal Management Analyst 1/24/2023



Aaron Gettis, Deputy County Counsel 1/19/2023

1  
2  
3  
4  
5  
6  
7  
8  
9  
10  
11  
12  
13  
14  
15  
16  
17  
18  
19  
20  
21  
22  
23  
24  
25  
26  
27  
28

ORDINANCE NO. 461.11

AN ORDINANCE OF THE COUNTY OF RIVERSIDE AMENDING ORDINANCE NO. 461  
RELATING TO COUNTY ROAD STANDARDS AND COUNTY STANDARD  
SPECIFICATIONS

The Board of Supervisors of the County of Riverside ordains as follows:

Section 1. Ordinance No. 461 is amended in its entirety to read as follows:

"ORDINANCE NO. 461.11

AN ORDINANCE OF THE COUNTY OF RIVERSIDE  
AMENDING ORDINANCE NO. 461 RELATING TO COUNTY  
ROAD STANDARDS AND COUNTY STANDARD  
SPECIFICATIONS

Section 1. FINDINGS. The Board of Supervisors finds the following:

- A. The County Road Standards and County Standard Specifications ("Standards") are used for the design and construction of road and other land division improvements within the unincorporated territory of the County of Riverside.
- B. The Standards are required to meet or exceed applicable federal and state regulations such as the Clean Water Act (CWA), American with Disabilities Act (ADA), and the California Building Code (CBC).
- C. The Standards were last comprehensively updated and adopted by the Board of Supervisors at its regular meeting on November 6, 2007, agenda item 3.50, as amended Ordinance No. 461.10.
- D. Updates to the Standards are necessary from time to time to ensure compliance with current applicable state and federal regulations, reflect advancements in technology, implement further public safety improvements, and clarify local requirements for the County road system.



1           Section 2.     PURPOSE.   The purpose of this ordinance is to do all of the  
2 following:

3           A.     Establish proper standards, specifications, and directions for the  
4 design and construction of road improvements, or other land  
5 division improvements, required to be constructed in the  
6 unincorporated territory of the County of Riverside.

7           B.     Adopt the Standards contained in the document entitled "County  
8 Road Standards and County Standard Specifications, Ordinance No.  
9 461, as Amended by Ordinance No. 461.11," attached hereto as  
10 "Exhibit A" and made a part hereof by reference.

11           Section 3.     AUTHORITY.   This ordinance is adopted pursuant to all of the  
12 following:

13           A.     Article XI, Section 7 of the California Constitution, which  
14 authorizes the County of Riverside to adopt ordinances and enforce  
15 within its limits all local, police, sanitary, and other ordinances and  
16 regulations not in conflict with general laws.

17           B.     California Streets and Highway Code sections 940 and 942, which  
18 authorizes a county board of supervisors to have control of the  
19 county highways, and to enact and enforce ordinances and  
20 regulations for the construction, improvement, or maintenance of  
21 county highways.

22           Section 4.     APPLICATION.

23           A.     General.     This ordinance shall apply to all public roadway  
24 improvements, and other land division improvements, within the  
25 unincorporated areas of the County of Riverside.

26           B.     Effect on Past Actions and Obligations.   The adoption of the  
27 Standards, as amended, does not affect any civil lawsuit instituted  
28 or filed or prosecutions for ordinance violations committed on or

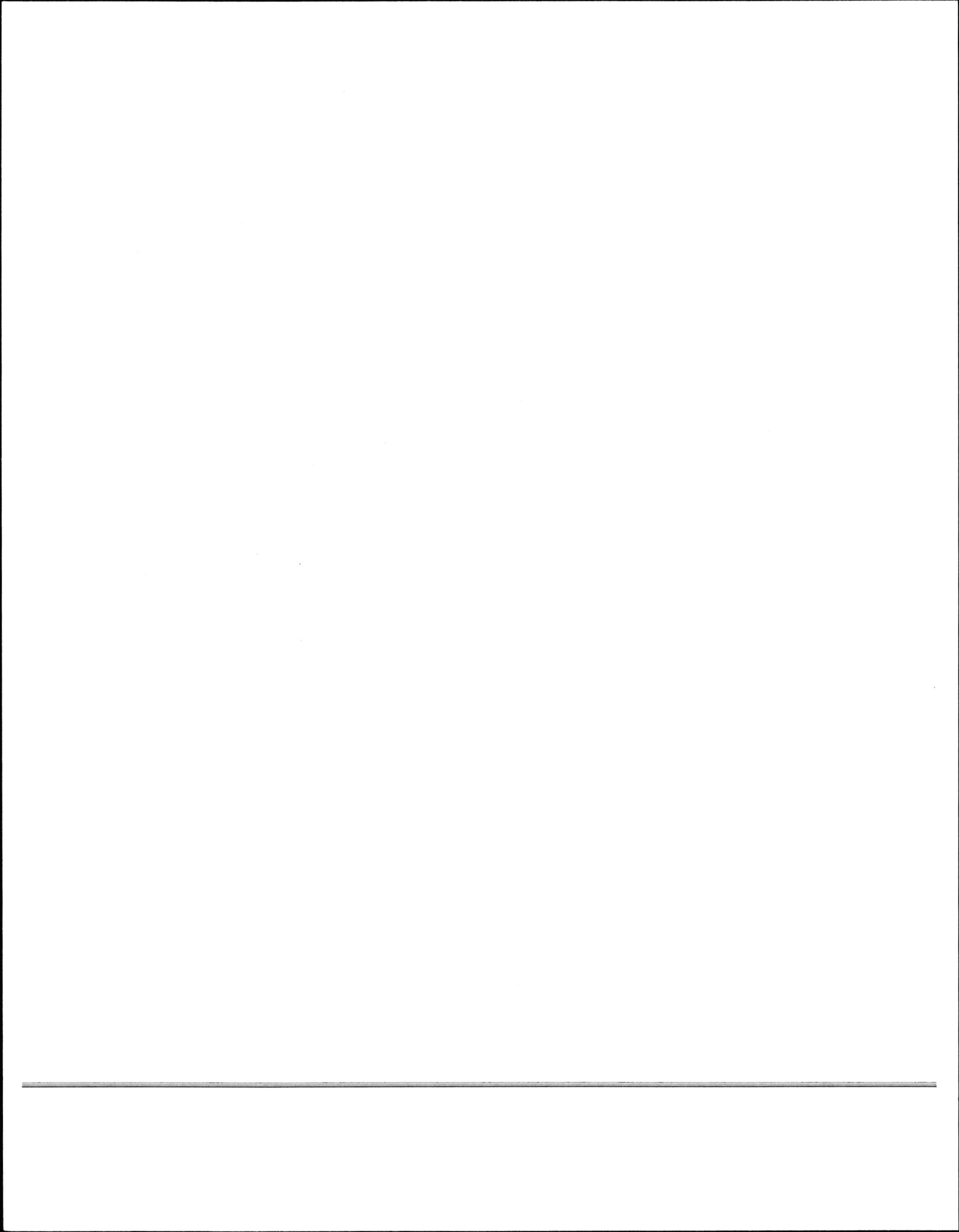

1 prior to the effective date of this ordinance, does not waive any fee  
2 or penalty due and unpaid prior to the effective date of this  
3 ordinance, and does not affect the validity of any bond or cash  
4 deposit posted, filed or deposited pursuant to the requirements of  
5 any ordinance.

6 C. References to Previous Versions of Ordinance No. 461. References  
7 in County forms, documents and regulations to the chapters and  
8 sections of Ordinance No. 461, 461.10, or earlier versions, shall be  
9 construed to apply to the corresponding provisions contained within  
10 this Ordinance No. 461.11.

11 D. No Permission to Violate Other County of Riverside Ordinances.  
12 The issuance or granting of any encroachment permit or approval of  
13 any plan, specification, computations, or inspection does not  
14 constitute a permit for, or an approval of, any violation of the  
15 provisions of any County of Riverside ordinance. The issuance of  
16 any encroachment permit or approval of any plan, specification,  
17 computations, or inspection presuming to grant authority to violate  
18 or cancel the provisions of any County of Riverside ordinance is not  
19 valid.

20 Section 5. The "County Road Standards and County Standard Specifications,"  
21 to establish proper standards, specifications, and directions for the design and construction  
22 of road improvements, or other land division improvements, required to be constructed in  
23 the unincorporated territory of the County of Riverside, are hereby adopted as described in  
24 the attached "Exhibit A" and incorporated herein."

25 ///

26 ///

27 ///

28 ///



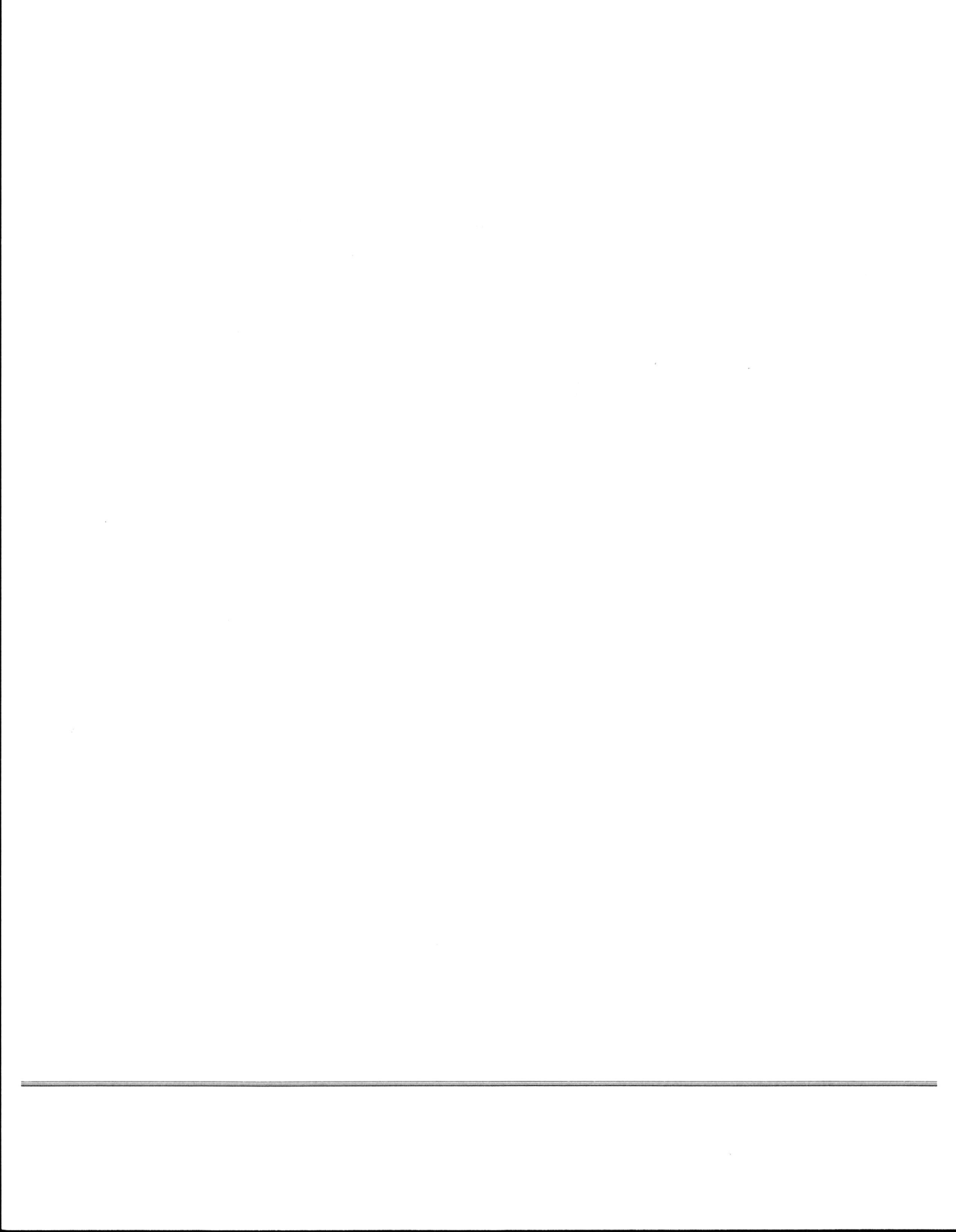

1        Section 2. EFFECTIVE DATE. This ordinance shall take effect thirty (30) days after its  
2 adoption.

3                                    BOARD OF SUPERVISORS OF THE  
4                                    COUNTY OF RIVERSIDE, STATE OF CALIFORNIA

5                                    By:   
6                                    Chair, Board of Supervisors  
7                                    KEVIN JEFFRIES

8 ATTEST:  
9 CLERK OF THE BOARD:  
10 KIMBERLY A. RECTOR

11 By:   
12 Deputy

13 (SEAL)

14 APPROVED AS TO FORM  
15 Date: January 11, 2023

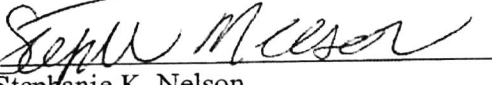
16 By:   
17 Stephanie K. Nelson  
18 Deputy County Counsel

KEVIN JEFFRIES

KEVIN JEFFRIES

10/10/2011

1  
2  
3  
4  
5  
6  
7  
8  
9  
10  
11  
12  
13  
14  
15  
16  
17  
18  
19  
20  
21  
22  
23  
24  
25  
26  
27  
28

STATE OF CALIFORNIA        )  
  )  
COUNTY OF RIVERSIDE        )        ss

I HEREBY CERTIFY that at a regular meeting of the Board of Supervisors of said county held on January 31 , 2023, the foregoing ordinance consisting of 2 Sections was adopted by the following vote:

AYES:        Jeffries, Spiegel, Washington, Perez, and Gutierrez  
NAYS:        None  
ABSENT:     None

DATE:        January 31, 2023

KIMBERLY A. RECTOR  
Clerk of the Board  
BY:   
Deputy

SEAL

10/10/10



EXHIBIT A

COUNTY ROAD STANDARDS AND  
COUNTY STANDARD SPECIFICATIONS

1  
2  
3  
4  
5  
6  
7  
8  
9  
10  
11  
12  
13  
14  
15  
16  
17  
18  
19  
20  
21  
22  
23  
24  
25  
26  
27  
28

---

**APPENDIX A - SUMMARY OF UPDATES**

to Ordinance No. 461.11 - County Road Standards and County Standard Specifications



## **Ordinance No. 461.11 - County Road Standards and County Standard Specifications**

### General Summary of Updates

Updates to the County Road Standards are necessary from time to time to ensure compliance with current applicable state and federal regulations, to reflect advancements in technology, to implement further public safety improvements, and to clarify local requirements for the County road system.

Listed below is a general summary of the types of updates made with the adoption of Ordinance No. 461.11.

1. Changed the type of street lights from High Pressure Sodium Vapor (HPSV) to Light-Emitting Diode (LED) to utilize latest technologies in the reduction of energy consumption costs. Added a street light standard for the Imperial Irrigation District service area.
  2. Added a standard for solar-powered flashing beacons and radar feedback signs to take advantage of advancements in solar power technology to reduce the costs of installation, maintenance, and energy consumption associated with wired equipment, and to reduce carbon emissions and effects on the environment, including air pollution and global warming, by using renewable energy sources.
  3. Replaced vehicle detection methods that used vehicle detection loops cut into the pavement with video/radar vehicle detection cameras to utilize latest technologies and to reduce maintenance costs associated with the reinstallation of loops after the repair or maintenance of road pavement.
  4. Added battery backup to traffic signals to improve traffic safety in the event of a power outage.
  5. Added a series of standard drawings for Full Trash Capture Devices designed to remove trash at storm water catch basins to improve the quality of water quality that reaches downstream water bodies, as implemented by the State Water Resources Control Board in 2017.
  6. Added standards for riprap around storm water facilities to reduce soil erosion from impacting downstream water quality and to reduce maintenance costs associated with repairing dirt slopes and cleaning deposited soils from downstream facilities.
  7. Added information to all applicable standards to make the County's pedestrian facilities (sidewalks, curb ramps, crosswalks, and pedestrian signals) accessible to persons with disabilities by meeting or exceeding the accessibility standards established by the federal American with Disabilities Act (ADA) and state California Building Code (CBC).
  8. Reduced the maximum design slopes of accessible pedestrian routes, including sidewalks and curb ramps, to accommodate construction tolerances, as a result of certain court rulings that have determined that tolerances in constructed improvements are not acceptable. As an example of the changes to the County standards, the slope of a curb ramp has been reduced from the state and federal maximum of 8.33% to 7.5% for use in the designing and construction forming of concrete improvements, for the purpose of achieving the federal and state maximum slope of 8.33% in the as-built condition. In addition, the cross slope of an accessible pedestrian route has
-

been reduced from the state and federal maximum of 2.00% to 1.5% for use in the designing and construction forming of concrete improvements, for the purpose of achieving the federal and state maximum slope of 2.00% in the as-built condition. This type of change is consistent with the changes made by Caltrans and other local agencies.

9. Added further notes and detail sheets to the Curb Ramp standard series to clarify accessibility requirements. Modified the Case A curb ramp geometry to provide more room for pedestrian access around traffic signal equipment. Added standards for additional curb ramp configurations. Removed the requirement for grooves around the perimeter of a curb ramp to be consistent with updated CBC standards that became effective in 2015.
10. Added a bicycle-safe drainage grate detail to improve safety for bicyclists.
11. Added a new standard for the Safety Edge treatment of the outer edge of roadways to improve vehicle recovery and traffic safety.
12. Decreased the gutter depression of curb-opening catch basins from 3 inches to 4 inches to decrease the dip at the outer edge of the roadway to increase road safety.
13. Increased the standard cross gutter width from 10 feet to 12 feet to protect the adjacent asphalt pavement surface from water damage and to reduce maintenance costs.
14. Revised intersection geometry on Urban, Arterial, Major, and Secondary Highways by replacing curved transitions with straight transitions on the outer curb alignment, which will provide a wider pavement width for motorists and simplify construction.
15. Updated, clarified, and added design requirements for corner sight distance design requirements, street name sign placement, and traffic signal equipment.
16. Renumbered standards 82 through 86 to organize the standards in order of number of lanes and right-of-way widths.
17. Applied a new title block to all sheets and updated the presentation of the drawings to improve clarity and consistency.

#### Table of Updates to Each Standard

A description of updates to each standard is provided in the attached table.

**Ordinance No. 461.11 County Road Standards and County Standard Specifications**

**SUMMARY OF UPDATES TO ORDINANCE No. 461.10**

Page No. in 2007 Riv Co Road Stds PDF	Std No.	Ordinance No. 461.10 (2007) Road Std Title	Ordinance No. 461.11 (NEW) Road Std Title	Deleted Standard	Added New Standard	Combined or Split Sheets	Applied Revised Border, Title Block	Reformatted Drafting	Modified Title of Standard	Updated Accessibility (ADA) Compliance	Removed Plastic Sheeting (See Std 401)	Added Subgrade Compaction Note	Updated Soil Note	Modified/Added Concrete Specification	Modified the Notes Section	Other Changes to Text, Details	Additional Notes / Comments
1		Index - Page 1	County Road Standards Index - Page 1 of 2				X	X	X								Revised for new, deleted, and modified standard titles and numbers.
2		Index - Page 2	County Road Standards Index - Page 2 of 2				X	X	X							X	
			Acronyms and Abbreviations (Sheet 1 of 3)		X												Added new listing of acronyms and abbreviations.
			Acronyms and Abbreviations (Sheet 2 of 3)		X												
			Acronyms and Abbreviations (Sheet 3 of 3)		X												
3	81-1	8-Lane Expressway (220' R/W)	8-Lane Expressway 152' Improvement (220' R/W)				X	X	X	X					X	X	Added conditional sidewalk.
4	81-2	8-Lane Expressway (220' R/W)	8-Lane Expressway 152' Improvement (220' R/W)				X	X	X								
5	82-1	6-Lane Expressway (220' R/W)	8-Lane Expressway 146' Improvement (220' R/W)				X	X	X	X					X	X	Renumbered old Std 82 to new Std 84. Renumbered old Std 86 to new Std 82. Changed old Std 86 from 6 to 8 lanes and 146' to 152' improvement width.
6	82-2	6-Lane Expressway (220' R/W)	8-Lane Expressway 146' Improvement (220' R/W)				X	X	X							X	
7	83-1	6-Lane Expressway (184' R/W)	8-Lane Expressway 134' Improvement (184' R/W)				X	X	X	X					X	X	Renumbered old Std 83 to new Std 85. Renumbered old Std 87 to new Std 83. Changed median curb notation.
8	83-2	6-Lane Expressway (184' R/W)	8-Lane Expressway 134' Improvement (184' R/W)				X	X	X								
9	84-1	6-Lane Expressway (150' R/W)	6-Lane Expressway 152' Improvement (220' R/W)				X	X	X	X					X		Deleted old Std 84. Renumbered old Std 82 to new Std 84. Added conditional sidewalk.
10	84-2	6-Lane Expressway (150' R/W)	6-Lane Expressway 152' Improvement (220' R/W)				X	X	X								
11	85-1	6-Lane Expressway (142' R/W)	6-Lane Expressway 110' Improvement (184' R/W)				X	X	X	X					X	X	Renumbered old Std 85 to new Std 86. Renumbered old Std 83 to new Std 85.
12	85-2	6-Lane Expressway (142' R/W)	6-Lane Expressway 110' Improvement (184' R/W)				X	X	X							X	
13	86-1	6-Lane Expressway (220' R/W)	6-Lane Expressway 110' Improvement (142' R/W)				X	X	X	X					X	X	Renumbered old Std 86 to new Std 82. Renumbered old Std 85 to new Std 86.
14	86-2	6-Lane Expressway (220' R/W)	6-Lane Expressway 110' Improvement (142' R/W)				X	X	X							X	
15	87-1	8-Lane Expressway (184' R/W)		X													Deleted these sheets. Renumbered old Std 87 to new Std 83.
16	87-2	8-Lane Expressway (184' R/W)		X													

Page No. in 2007 Riv Co Road Stds PDF	Std No.	Ordinance No. 461.10 (2007) Road Std Title	Ordinance No. 461.11 (NEW) Road Std Title	Deleted Standard	Added New Standard	Combined or Split Sheets	Applied Revised Border, Title Block	Reformatted Drafting	Modified Title of Standard	Updated Accessibility (ADA) Compliance	Removed Plastic Sheeting (See Std 401)	Added Subgrade Compaction Note	Updated Soil Note	Modified/Added Concrete Specification	Modified the Notes Section	Other Changes to Text, Details	Additional Notes / Comments	
17	91-1	Urban Arterial Highway (152' R/W)					X	X		X						X	X	
18	91-2	Urban Arterial Highway (152' R/W)					X	X									X	Remove curve in approaching curb and use straight transition.
19	92-1	Arterial Highway (128' R/W)					X	X		X						X	X	
20	92-2	Arterial Highway (128' R/W)					X	X									X	Remove curve in approaching curb and use straight transition.
21	93-1	Major Highway (118' R/W)					X	X		X						X	X	
22	93-2	Major Highway (118' R/W)					X	X									X	Remove curve in approaching curb and use straight transition.
23	94-1	Secondary Highway (100' R/W)					X	X		X						X	X	
24	94-2	Secondary Highway (100' R/W)					X	X									X	Remove curve in approaching curb and use straight transition.
25	95	Mountain Arterial Highway (110' R/W)					X	X								X	X	
26	103	Collector Street (No Access)	Collector Street (No Access) (74' R/W)				X	X	X	X						X	X	
27	104	Enhanced Local Street Adjacent To School or Park	104-1 Enhanced Local Street Adjacent To School or Park (66' R/W)			X	X	X	X	X						X	X	Modified Section "B" to include curb & gutter on both sides.
			104-2 Enhanced Local Street Adjacent To School or Park (66' R/W)		X													
28	105-1	Local Street (56' R/W)	105B Short Local Street (56' R/W)				X	X	X	X						X	X	Renumbered old Std 105-1 to Std 105B. Added curb & gutter.
29	105-2	Local Street (60' R/W)	105A Exterior & Local Street (60' R/W)				X	X	X	X						X	X	Renumbered old Std 105-2 to Std 105A. Added curb & gutter.
			105C Unpaved Local Road / Unpaved Access Road (60' R/W)		X													Added new standard for unpaved roads to be improved with aggregate base.
30	106	Offsite Access Road (60' R/W)	Access Road, Constrained Local Street or Private Street (50'-60' R/W)				X	X	X							X	X	Modified Section "B" to include curb & gutter on both sides.
31	107	Local Frontage Road	Local Frontage Road (52' R/W)				X	X	X	X						X	X	
32	107A	Collector Frontage Road	Collector Frontage Road (59' R/W)				X	X	X	X						X	X	
33	108	Secondary Frontage Road	Secondary Frontage Road (82' R/W)				X	X	X	X							X	
34	109	Major Frontage Road	Major Frontage Road (97' R/W)				X	X	X	X						X	X	
35	111	Industrial Collector Street (78' R/W)					X	X		X						X	X	
36	112	Local Mountain Residential Street (50' R/W)					X	X								X	X	
37	113	Landscape Median					X	X					X			X	X	
38	113A	Crossover Median					X	X								X	X	Added PCC minimum thickness and AB under PCC crossover median.

Page No. in 2007 Riv Co Road Stds PDF	Std No.	Ordinance No. 461.10 (2007) Road Std Title	Ordinance No. 461.11 (NEW) Road Std Title	Deleted Standard	Added New Standard	Combined or Split Sheets	Applied Revised Border, Title Block	Reformatted Drafting	Modified Title of Standard	Updated Accessibility (ADA) Compliance	Removed Plastic Sheeting (See Std 401)	Added Subgrade Compaction Note	Updated Soil Note	Modified/Added Concrete Specification	Modified the Notes Section	Other Changes to Text, Details	Additional Notes / Comments	
39	114	Roadway Design Requirements	<b>114-1</b>			X	X	X								X	X	Added 105A and 105B. Added Curb Return Radius.
			<b>114-2</b>		X			X									X	
40	<b>115</b>	Local and Collector Street Bridge					X	X		X						X	X	
41	<b>116</b>	Urban Arterial Highway Bridge					X	X		X						X	X	
42	<b>117</b>	Arterial Highway Bridge					X	X		X						X	X	Added sidewalk slope. Deleted barrier widths.
43	<b>118</b>	Major Highway Bridge					X	X		X						X	X	
44	<b>119</b>	Secondary Highway Bridge					X	X		X						X	X	
45	<b>136</b>	Collector Rural Road	Collector Rural Road (60' R/W)				X	X	X								X	Changed Caltrans Std A87 to A87B.
46	<b>138</b>	Residential Rural Road	Residential Rural Road (60' R/W)				X	X	X								X	
47	<b>200</b>	Type A-6 Curb	Type A-6 Curb and Gutter 6" Curb Face				X	X	X			X	X					
48	<b>201</b>	Type A-8 Curb	Type A-8 Curb and Gutter 8" Curb Face				X	X	X			X	X					
49	<b>202</b>	Type "C" Curb	Type "C" Curb Rolled Curb				X	X	X			X	X					
			<b>202A</b> Type "W" Curb Wedge Curb		X												X	Added new curb standard.
50	<b>203</b>	Type "D-1" Curb for Existing Pavement	Type "D-1" Curb Only on Existing Pavement				X	X	X			X	X	X			X	
51	<b>204</b>	Type "D" Curb	Type "D" Curb Only				X	X	X				X				X	Added details for sawcutting existing pavement.
52	<b>205</b>	Curb and Gutter Joints					X	X									X	Added 50' interval of expansion joints.
53	<b>206</b>	Residential Driveway with A.C. Dike	Residential Driveway with HMA Dike				X	X	X	X		X				X	X	
54	<b>207</b>	Residential Driveway with Sidewalk at Curb	Residential Drive Approach with Sidewalk at Curb				X	X	X	X		X	X	X	X	X	X	
55	207A-1	Commercial Driveway (with Sidewalk at Curb)	<b>207A-1</b> Commercial Drive Approach (with Sidewalk at Curb)			X	X	X	X	X	X	X	X	X	X	X	X	
			<b>207A-2</b> Commercial Drive Approach (with Sidewalk at Curb)		X		X	X	X	X								Modified callout for tooled joints.
56	207A-2	Commercial Driveway (with Sidewalk at R/W)	<b>207A-3</b> Commercial Drive Approach (with Sidewalk at R/W)			X	X	X	X	X	X	X	X	X	X	X	X	
			<b>207A-4</b> Commercial Drive Approach (with Sidewalk at R/W)		X		X	X	X	X								
57	<b>208</b>	Driveway Locations at Intersection Curb Returns	Driveway Approach Locations at Intersection Curb Returns				X	X	X									
58	<b>209-1</b>	Cross Gutter (Layout)	Cross Gutter and Spandrel (Layout)				X	X	X							X	X	Increased cross gutter width from 10' to 12'.
59	<b>209-2</b>	Cross Gutter (Typical Section)	Cross Gutter and Spandrel (Typical Section)				X	X	X		X	X	X	X	X	X	X	Increased thickness of concrete at joint.
60	<b>210</b>	Cross Gutter with Splash Area	Cross Gutter and Spandrel with Splash Area				X	X	X		X	X	X	X	X	X	X	Increased thickness of concrete at joint.
61	<b>211</b>	Curb Transition					X	X									X	
62	<b>212</b>	Asphalt Concrete Dikes	Hot Mix Asphalt Dikes				X	X	X								X	X

Page No. in 2007 Riv Co Road Stds PDF	Std No.	Ordinance No. 461.10 (2007) Road Std Title	Ordinance No. 461.11 (NEW) Road Std Title	Deleted Standard	Added New Standard	Combined or Split Sheets	Applied Revised Border, Title Block	Reformatted Drafting	Modified Title of Standard	Updated Accessibility (ADA) Compliance	Removed Plastic Sheeting (See Std 401)	Added Subgrade Compaction Note	Updated Soil Note	Modified/Added Concrete Specification	Modified the Notes Section	Other Changes to Text, Details	Additional Notes / Comments
63	213	Residential Driveway with Sidewalk at R/W	213-1 Residential Driveway Approach with Sidewalk at R/W			X	X	X	X	X	X	X	X	X	X	X	Modified callout for tooled joints.
			213-2 Residential Driveway Approach with Sidewalk at R/W		X		X	X		X							
			214-1 Safety Edge		X												Added new safety edge standard.
			214-2 Safety Edge		X												
64	300-1	Curb Inlet Catch Basin					X	X		X	X						Decreased gutter depression from 4" to 3".
65	300-2	Curb Inlet Catch Basin (Specs)	Curb Inlet Catch Basin				X	X	X				X	X	X	X	
66	300A	Fossil Filter					X	X									
67	301	Combination Inlet Catch Basin No. 1	301-1			X	X	X	X		X						
			301-2		X		X	X					X	X	X	X	
68	302-1	Combination Inlet Catch Basin No. 2					X	X			X						
69	302-2	Combination Inlet Catch Basin Specifications	Combination Inlet Catch Basin No. 2				X	X	X				X	X	X		
70	303-1	Flat Outlet Drainage Structure					X	X		X							
71	303-2	Flat Outlet Drainage Structure Details	Flat Outlet Drainage Structure				X	X	X				X	X			
72	304	Curb Support Detail					X	X									Decreased gutter depression from 4" to 3".
73	305	Grate and Frame Detail	305-1			X	X	X									X
			305-2		X		X	X									X
74	306	Asphalt Concrete Overside Drain	Hot Mix Asphalt Overside Drain				X	X	X								
75	307	P.C.C. Dip Section	PCC Dip Section				X	X	X		X		X	X			X
76	308-1	Curb Outlet	Curb Outlet Drain				X	X	X								
77	308-2	Curb Outlet	Curb Outlet Drain				X	X	X				X	X			
78	309	Under Sidewalk Drain Cast In Place					X	X		X			X	X			
79	310	Private Drain Through Curb					X	X		X				X			Added option for multiple pipes.
80	311	Gutter Depression for Curb Opening Catch Basins	311-1			X	X	X					X				Decreased gutter depression from 4" to 3".
			311-2		X		X	X									
81	312	Gutter Depression for Grate Opening Catch Basin	312-1			X	X	X					X	X			Decreased gutter depression from 4" to 3".
			312-2		X												

Page No. in 2007 Riv Co Road Stds PDF	Std No.	Ordinance No. 461.10 (2007) Road Std Title	Ordinance No. 461.11 (NEW) Road Std Title	Deleted Standard	Added New Standard	Combined or Split Sheets	Applied Revised Border, Title Block	Reformatted Drafting	Modified Title of Standard	Updated Accessibility (ADA) Compliance	Removed Plastic Sheeting (See Std 401)	Added Subgrade Compaction Note	Updated Soil Note	Modified/Added Concrete Specification	Modified the Notes Section	Other Changes to Text, Details	Additional Notes / Comments	
			313-1 Full Trash Capture Device (FTCD) Connector Pipe Screen (CPS)		X												Added new FTCD standards.	
			313-2 Full Trash Capture Device (FTCD) Connector Pipe Screen (CPS)		X													
			313-3 Full Trash Capture Device (FTCD) Connector Pipe Screen (CPS)		X													
			313-4 Full Trash Capture Device (FTCD) Connector Pipe Screen (CPS)		X													
			313-5 Full Trash Capture Device (FTCD) Connector Pipe Screen (CPS)		X													
			313-6 Full Trash Capture Device (FTCD) Connector Pipe Screen (CPS)		X													
			313-7 Full Trash Capture Device (FTCD) Connector Pipe Screen (CPS)		X													
			313-8 Full Trash Capture Device (FTCD) Connector Pipe Screen (CPS)		X													
			313-9 Full Trash Capture Device (FTCD) Connector Pipe Screen (CPS)		X													
			313-10 Full Trash Capture Device (FTCD) Connector Pipe Screen (CPS)		X													
			313-11 Full Trash Capture Device (FTCD) Connector Pipe Screen (CPS)		X													
			313-12 Full Trash Capture Device (FTCD) Connector Pipe Screen (CPS)		X													
			313-13 Full Trash Capture Device (FTCD) Connector Pipe Screen (CPS)		X													
			313-14 Full Trash Capture Device (FTCD) Connector Pipe Screen (CPS)		X													
			314-1 Riprap Energy Dissipator and Apron at Wingwall Storm Drain Outfall		X												Added new riprap standards.	
			314-2 Riprap Energy Dissipator at V-Ditch Outfall		X													
			314-3 Riprap Energy Dissipator and Apron at Straight Headwall Outfall		X													
			313-4 Riprap Energy Dissipator Sizing and Concrete Sill		X													

Page No. in 2007 Riv Co Road Stds PDF	Std No.	Ordinance No. 461.10 (2007) Road Std Title	Ordinance No. 461.11 (NEW) Road Std Title	Deleted Standard	Added New Standard	Combined or Split Sheets	Applied Revised Border, Title Block	Reformatted Drafting	Modified Title of Standard	Updated Accessibility (ADA) Compliance	Removed Plastic Sheeting (See Std 401)	Added Subgrade Compaction Note	Updated Soil Note	Modified/Added Concrete Specification	Modified the Notes Section	Other Changes to Text, Details	Additional Notes / Comments
82	400-1	Sidewalk, Fire Hydrant, & Utility Pole Location (Sidewalk at Curb)					X	X									Reduced sidewalk width behind utility pole from 6' to 5'.
83	400-2	Sidewalk, Fire Hydrant, & Utility Pole Location (Sidewalk at R/W)					X	X						X		X	
84	401	Sidewalk and Curb					X	X		X			X	X	X	X	Expanded the area of aggregate base and plastic sheeting for certain soil types.
85	403-1	Curb Ramp Case A					X	X		X	X	X			X	X	Revised curb ramp geometry. Removed requirement for grooves. Called out tooled joints. Reduced curb ramp slope from 8.33% to 7.5%. Reduced cross slope from 2.00% to 1.5%. Reduced transition side slope from 10.00% to 9%.
86	403-2	Curb Ramp Case B					X	X		X	X	X			X	X	Removed requirement for grooves. Called out tooled joints. Reduced ramp slope from 8.33% to 7.5%. Reduced cross slope from 2.00% to 1.5%.
87	403-3	Curb Ramp	Curb Ramp Profile				X	X	X	X						X	Modified the table (Case A) for revised slopes. Added a table for Case B and Case C.
88	403-4	Curb Ramp Construction Notes	403-7 Curb Ramp Notes				X	X	X	X			X	X	X		Expanded and clarified notes.
			403-4 Curb Ramp Case C "T" Intersection with Sidewalk at Curb		X												Added a new detail for parallel curb ramp with sidewalk at curb.
			403-5 Curb Ramp Case D "T" Intersection with Sidewalk at R/W		X												Added a new detail for curb ramp with sidewalk at R/W.
			403-6 Curb Ramp Case C and D Location at "T" Intersection		X												Added a new detail to show curb ramp locations at T-intersections.
89	404	Meandering Sidewalk					X	X		X	X		X	X	X	X	Added accessibility note.
90	405-1	Multipurpose Trail	405				X	X	X	X					X	X	Moved sidewalk location. Added note to refer to Riverside Comprehensive Landscape Guidelines and Standards for fencing requirements.
91	405-2	Multipurpose Trail		X													Removed sheet with fencing details (see comment above).
92	500	Typical Alley and Alley Apron Sections	Alley and Alley Apron Sections				X	X	X	X		X	X	X	X	X	Re-designed to meet ADA requirements.
93	600	Sewer House Connection					X	X									
94	601	Sewer Chimney Pipe					X	X						X			
95	603	Sewer Cleanout					X	X						X			



Page No. in 2007 Riv Co Road Stds PDF	Ordinance No. 461.10 (2007) Road Std Title	Ordinance No. 461.11 (NEW) Road Std Title	Deleted Standard	Added New Standard	Combined or Split Sheets	Applied Revised Border, Title Block	Reformatted Drafting	Modified Title of Standard	Updated Accessibility (ADA) Compliance	Removed Plastic Sheeting (See Std 401)	Added Subgrade Compaction Note	Updated Soil Note	Modified/Added Concrete Specification	Modified the Notes Section	Other Changes to Text, Details	Additional Notes / Comments
96	604 Sewer Manhole		X													Deleted standards since pre-cast concrete is now used instead of brick.
97	605 Deep Sewer Manhole		X										X			
98	606 Pre-Cast Concrete Manhole (Eccentric)					X	X						X			
99	607 Pre-Cast Concrete Manhole (Concentric)					X	X						X			
100	608 Manhole Frames and Covers					X	X	X								
101	610 Pre-Cast Rectangular Shallow Manhole					X	X									
102	611 Rectangular Manhole Frame and Cover					X	X								X	Modified geometrics.
103	612 Paving Detail Around Manhole in Unpaved Area					X	X					X		X		
104	700 Typical Water Meter Installation	Water Meter Installation				X	X	X				X		X		Increased cover over water main from 36" to 48" to match Std 817.
105	701 Fire Hydrant Installation					X	X					X		X		Changed 18" setback from flow line to nearest part of FH. Increased cover over water main from 36" to 48" to match Std 817.
106	702 Fire Hydrant Installation (Alternate)					X	X						X			Increased cover over water main from 36" to 48" to match Std 817. Changed ordinance reference.
107	703 Valve Box, Frame and Cover					X	X									Increased cover over water main from 36" to 48" to match Std 817.
108	800 Cul-De-Sac					X	X									Added 50' R/W. Deleted 60'/20' combination row. Revised table values.
109	800A Offset Cul-De-Sac					X	X									Added 50' R/W. Deleted 60'/20' combination row. Revised table values.
110	801 Standard Knuckle	801-1 Knuckle				X	X	X								
		801-2 Knuckle				X	X	X								Added 50' R/W. Deleted 60'/20' combination row. Revised table values.
111	802 Frontage Road Intersection					X	X	X								
112	803 Private Road Connection (Rural Area)					X	X	X							X	Added notation to handle drainage with pipe or cross gutter.
113	805 Property Line Corner Cut-Back, Curb Return Radius	805-1				X	X	X						X		
		805-2				X										Added detail for corner cutbacks for Schedule A Subdivisions with Entry Statements.

Page No. in 2007 Riv Co Road Stds PDF	Std No.	Ordinance No. 461.10 (2007) Road Std Title	Ordinance No. 461.11 (NEW) Road Std Title	Deleted Standard	Added New Standard	Combined or Split Sheets	Applied Revised Border, Title Block	Reformatted Drafting	Modified Title of Standard	Updated Accessibility (ADA) Compliance	Removed Plastic Sheeting (See Std 401)	Added Subgrade Compaction Note	Updated Soil Note	Modified/Added Concrete Specification	Modified the Notes Section	Other Changes to Text, Details	Additional Notes / Comments
			806 Entry Street 50' Imp / 80' R/W		X												Added new standard.
114	810	Barricade					X	X							X		Added note to meet Caltrans requirements.
115	812	Multiple Mailbox Installation for New Sidewalk					X	X							X	X	Modified geometry of sidewalk around mailbox.
116	813	Multiple Mailbox Installation for Existing Sidewalk					X	X							X	X	
117	814	Bus Turnout					X	X		X					X	X	
118	815	Street Name Sign (Curb to Curb Width Greater than 40')		X													Deleted this standard number. Moved to new Std 1220.
119	816	Street Name Sign (Curb to Curb Width Less than 40')		X													Deleted this standard number. Moved to new Std 1221.
120	817-1	Underground Utility Locations					X	X							X	X	Changed the minimum cover over gas lines from 2.5' to 3.5' and 4.0'.
121	817-2	Underground Utility Locations					X	X							X	X	
122	818	Utility Trench Backfill					X	X							X	X	Updated notes.
123	819	Location of Cable TV Ducts at Street Intersections					X	X									
124	820	Fixed Object Placement for Interim Roadway Conditions	Fixed Object Placement for Roadways without Curbs				X	X	X								
125	821	Intersection Sight Distance					X	X							X	X	Updated notes.
126	900	Tie-Out Standards					X	X							X		
127	901	Street Centerline Monument					X	X							X		
128	903	Type "B" Monument					X	X									
129	1000	Residential Lighting	1000-1 Street Lighting (Southern California Edison (SCE) Electric Serving Area)			X	X	X	X						X	X	Changed luminaire from HPSV to LED. Added tables. Updated notes.
			1000-2 Street Lighting (Imperial Irrigation District (IID) Electric Serving Area)		X												Added new standard for street lights in Imperial Irrigation District service area.
			1000-3 Street Lighting		X												Added details for sidewalk location around street lights.
130	1001	Arterial Highway Lighting		X													Deleted this standard. Combined information into Std 1000-1.
131	1101	Tree Setbacks at Corner Cut-Backs and Driveways					X	X									
			1102 Tree Staking Detail		X												Added new landscaping standards.
			1103 Backflow Prevention Device Installation		X												
132	1200	Traffic Signal Pole IISNS Straight Arm Mounting Detail	IISNS Mast Arm Detail				X	X	X						X	X	Modified dimensions.

Page No. in 2007 Riv Co Road Stds PDF	Std No.	Ordinance No. 461.10 (2007) Road Std Title	Ordinance No. 461.11 (NEW) Road Std Title	Deleted Standard	Added New Standard	Combined or Split Sheets	Applied Revised Border, Title Block Reformatted Drafting	Modified Title of Standard	Updated Accessibility (ADA) Compliance	Removed Plastic Sheeting (See Std 401)	Added Subgrade Compaction Note	Updated Soil Note	Modified/Added Concrete Specification	Modified the Notes Section	Other Changes to Text, Details	Additional Notes / Comments
133	1201	Type E Loop Detector Sawcut & Replacement Detail	1206 Loop Detector Detail				X X X								X	Renumbered old Std 1201 to new Std 1206. Updated table and details. New Std 1201 is IISNS Detail.
			1201 IISNS Detail		X											Added new standard for internally illuminated signal name sign.
134	1202	Traffic Signal Detail Sheet	1202-1 Traffic Signal Detail			X	X X X X							X	X	Updated specifications.
			1202-2 Traffic Signal Detail		X											Added battery backup system details.
			1202-3 Traffic Signal Detail		X											Deleted loop detection. Replaced with video/radar detection.
135	1203	Case "A" Detection Input		X												
136	1204	Case "B" Detection Input		X												
			1205 Video/Radar Detection Detail		X											
			1207-1 ATS Detection Input Assignments		X											
			1207-2 170 & 2070 Detection Input Assignments		X											
			1210 Striping Details and Construction Notes		X											Added new traffic standards.
			1211 Crosswalk and Limit Line Detail		X											
			1215 Solar Powered Flashing Beacon		X											
			1216 Solar Powered Radar Speed Feedback Sign - Local Road		X											
			1217 Solar Powered Radar Speed Feedback Sign - Highway		X											
			1220-1 Street Name Sign (Curb to Curb Width Greater than 60')		X	X	X X X X X							X	X	Renumbered old Std 815 to new Std 1220. Details and notes fully reworked.
			1220-2 Street Name Sign (Curb to Curb Width Greater than 60')		X											
			1221-1 Street Name Sign (Curb to Curb Width Less than or Equal to 60')		X	X	X X X X X							X	X	Renumbered old Std 816 to new Std 1221. Details and notes fully reworked.
			1221-2 Street Name Sign (Curb to Curb Width Less than or Equal to 60')		X											
			1222-1 Sign Post Installation		X											
			1222-2 Sign Post Installation		X											Added new traffic standards.
			1223 No Parking Sign RV's / Trailers		X											
			1225 Advance Street Name Sign		X											
				10	63	19	135	136	63	48	12	14	29	25	67	84



Lead Agency: TRANSPORTATION DEPARTMENT  
ATTN: JAN BULINSKI  
Address: 3525 14TH STREET  
RIVERSIDE CA, 92501

**FILED / POSTED**

County of Riverside  
Peter Aldana  
Assessor-County Clerk-Recorder

E-202300116  
01/31/2023 01:00 PM Fee: \$ 50.00  
Page 1 of 3

Removed: \_\_\_\_\_ By: \_\_\_\_\_ Deputy  

Project Title

ORDINANCE NO.461.11-COUNTY ROAD STANDARDS AND COUNTY STANDARD SPECIFICATIONS.

Filing Type

- Environmental Impact Report
- Mitigated/Negative Declaration
- Notice of Exemption
- Other:

Notes



**COUNTY OF RIVERSIDE**  
**TRANSPORTATION AND**  
**LAND MANAGEMENT AGENCY**

*Mojahed Salama, P.E.*  
*Deputy for Transportation/Capital*  
*Projects*

*Russell Williams*  
*Deputy for Transportation/Planning and*  
*Development*

*Mark Lancaster, P.E.*  
*Director of Transportation*

**Transportation Department**

**NOTICE OF EXEMPTION**

October 27, 2022

**PROJECT TITLE: Ordinance No. 461.11 - County Road Standards and County Standard Specifications**

Work Order #Z572400 Task Code #ZORD

**PROJECT SPONSOR: County of Riverside Transportation Department**

**PROJECT LOCATION: Unincorporated Riverside County**

**SUPERVISORIAL DISTRICT: All**

**PROJECT DESCRIPTION:** The County of Riverside Transportation Department is proposing the adoption of Ordinance 461.11 to amend Ordinance No. 461 to authorize the Director of Transportation, or designee, to make modifications to the County Road Standards and County Standard Specifications, as deemed necessary to keep the standards current with applicable regulations, changing technologies, and best management practices.

Ordinance No. 461 consists of the County Road Standards and County Standard Specifications used for the design and construction of public roadway improvements in the unincorporated areas of the County of Riverside. The Standards were last comprehensively updated and adopted by the Board of Supervisors through Ordinance 461.10 at its regular meeting on November 6, 2007. The Standards have again been comprehensively updated to reflect the following:

- Incorporation of the most current state and federal regulations, including:
  - Americans with Disabilities Act
  - California Manual of Uniform Traffic Control Device
  - California Building Code
  - California Water Code
- Updated technology in traffic signal electrical, communications, and street lighting equipment
- Water quality features to capture trash and reduce sediment entering water courses
- Improved access for persons with disabilities
- Improvements in safety for motorists, pedestrians, and bicyclists
- A document with improved consistency and clarity for use by engineers, architects, contractors, inspectors, and other that have an interest in the public road system
- The latest design, construction, and maintenance management practices to enhance the service life of County's road system

01.31.23 3.25

**ENVIRONMENTAL ANALYSIS:**

**The County of Riverside Transportation Department has found that the above-described project is exempt from the provisions of the California Environmental Quality Act (CEQA), based on the following:**

**Section 15061(b)(3)** – Common Sense Exemption – Ordinance No. 461.11 is exempt pursuant to State CEQA Guidelines section 15061(b)(3) because it can be seen with certainty that there is no possibility that the amendment to Ordinance No. 461 may have a significant effect on the environment. The revisions to Ordinance No. 461 propose to authorize the Director of Transportation, or designee, to make modifications to the County Road Improvement Standards and Specifications, as deemed necessary to keep the standards current with applicable regulations, changing technologies, and best management practices. None of these activities have any significant effect on the environment. Amendment to Ordinance No. 461 does not lead to any direct improvements, developments, or any other projects. Any future improvements, developments or other projects that may be constructed as a result of the amendment to Ordinance No. 461 will be subject to a separate CEQA evaluation. As a result, adoption of Ordinance No. 461.11 is exempt from CEQA and there is no possibility that this amendment will cause a significant impact on the environment.

By: David Castro, Associate Transportation Planner

Signed: \_\_\_\_\_

*Jan Bulinski*  
Jan Bulinski, Environmental Project Manager

**County of Riverside, State of California**

**COUNTY ROAD STANDARDS AND  
COUNTY STANDARD SPECIFICATIONS**



**Ordinance No. 461**

**As amended by Ordinance No. 461.11**

**Adopted January 31, 2023**

**Effective March 2, 2023**

**ORDINANCE No. 461**  
COUNTY ROAD STANDARDS  
and  
COUNTY STANDARD SPECIFICATIONS

***PREFACE***

The County of Riverside Ordinance No. 461 is comprised of two sections: the County Road Standards and the County Standard Specifications. This amended Ordinance No. 461.11 adopted January 31, 2023 has an effective date of March 2, 2023 and supersedes all previously adopted versions. All units are U.S. Customary Units.



# COUNTY ROAD STANDARDS

## INDEX - PAGE 1 OF 2

### EXPRESSWAYS

- 81 8-LANE EXPRESSWAY (152' IMP, 220' R/W)
- 82 8-LANE EXPRESSWAY (146' IMP, 220' R/W)
- 83 8-LANE EXPRESSWAY (134' IMP, 184' R/W)
- 84 6-LANE EXPRESSWAY (152' IMP, 220' R/W)
- 85 6-LANE EXPRESSWAY (110' IMP, 184' R/W)
- 86 6-LANE EXPRESSWAY (110' IMP, 142' R/W)

### GENERAL PLAN HIGHWAYS

- 91 URBAN ARTERIAL HIGHWAY..... 152' R/W
- 92 ARTERIAL HIGHWAY..... 128' R/W
- 93 MAJOR HIGHWAY..... 118' R/W
- 94 SECONDARY HIGHWAY..... 100' R/W
- 95 MOUNTAIN ARTERIAL HIGHWAY..... 110' R/W

### STREETS / FRONTAGE ROADS

- 103 COLLECTOR STREET..... 74' R/W  
(NO ACCESS)
- 104 ENHANCED LOCAL STREET..... 66' R/W
- 105A EXTERIOR & LOCAL STREET..... 60' R/W
- 105B SHORT LOCAL STREET..... 56' R/W
- 105C AB LOCAL ROAD/ AB ACCESS RD..... 60' R/W
- 106 ACCESS ROAD, CONSTRAINED  
LOCAL OR PRIVATE STREET..... 50'-60' R/W
- 107 LOCAL FRONTAGE ROAD..... 52' R/W
- 107A COLLECTOR FRONTAGE ROAD..... 59' R/W
- 108 SECONDARY FRONTAGE ROAD..... 82' R/W
- 109 MAJOR FRONTAGE ROAD..... 97' R/W
- 111 INDUSTRIAL COLLECTOR STREET... 78' R/W
- 112 LOCAL MOUNTAIN RES. STREET..... 50' R/W

### MEDIANS

- 113 LANDSCAPED MEDIAN
- 113A CROSSOVER MEDIAN

### ROADWAY DESIGN

- 114 ROADWAY DESIGN REQUIREMENTS

### BRIDGES

- 115 LOCAL AND COLLECTOR STREET BRIDGE
- 116 URBAN ARTERIAL HIGHWAY BRIDGE
- 117 ARTERIAL HIGHWAY BRIDGE
- 118 MAJOR HIGHWAY BRIDGE
- 119 SECONDARY HIGHWAY BRIDGE

### RURAL ROADS

- 136 COLLECTOR RURAL ROAD.....60' R/W
- 138 RESIDENTIAL RURAL ROAD..... 60' R/W

### CURBS, GUTTERS AND DRIVEWAYS

- 200 TYPE A-6 CURB AND GUTTER - 6" CURB FACE
- 201 TYPE A-8 CURB AND GUTTER - 8" CURB FACE
- 202 TYPE "C" CURB - ROLLED CURB
- 202A TYPE "W" CURB - WEDGE CURB
- 203 TYPE "D-1" CURB ONLY ON EXISTING PAVEMENT
- 204 TYPE "D" CURB ONLY
- 205 CURB AND GUTTER JOINTS
- 206 RESIDENTIAL DRIVE APPROACH WITH HMA DIKE
- 207 RESIDENTIAL DRIVE APPROACH WITH SIDEWALK  
AT CURB
- 207A COMMERCIAL DRIVE APPROACH
- 208 DRIVE APPROACH LOCATIONS AT INTERSECTION  
CURB RETURNS
- 209 CROSS GUTTER AND SPANDREL
- 210 CROSS GUTTER AND SPANDREL WITH SPLASH  
AREA
- 211 CURB TRANSITION
- 212 HOT MIX ASPHALT DIKES
- 213 RESIDENTIAL DRIVE APPROACH WITH  
SIDEWALK AT R/W
- 214 SAFETY EDGE

### DRAINAGE

- 300 CURB INLET CATCH BASIN
- 300A FOSSIL FILTER
- 301 COMBINATION INLET CATCH BASIN No. 1
- 302 COMBINATION INLET CATCH BASIN No. 2
- 303 FLAT OUTLET DRAINAGE STRUCTURE
- 304 CURB SUPPORT DETAIL
- 305 GRATE AND FRAME DETAIL
- 306 HOT MIX ASPHALT OVERSIDE DRAIN
- 307 PCC DIP SECTION
- 308 CURB OUTLET DRAIN
- 309 UNDER SIDEWALK DRAIN CAST IN PLACE
- 310 PRIVATE DRAIN THROUGH CURB
- 311 GUTTER DEPRESSION FOR CURB  
OPENING CATCH BASINS
- 312 GUTTER DEPRESSION FOR GRATE  
OPENING CATCH BASINS
- 313 FULL TRASH CAPTURE DEVICE -  
CONNECTOR PIPE SCREEN
- 314 RIPRAP ENERGY DISSIPATER

# COUNTY ROAD STANDARDS

## INDEX - PAGE 2 OF 2

### SIDEWALKS AND TRAILS

- 400 SIDEWALK, FIRE HYDRANT, AND UTILITY POLE LOCATION
- 401 SIDEWALK AND CURB
- 403 CURB RAMP
- 404 MEANDERING SIDEWALK
- 405 MULTIPURPOSE TRAIL

### ALLEYS

- 500 ALLEY AND ALLEY APRON SECTIONS

### SEWERS

- 600 SEWER HOUSE CONNECTION
- 601 SEWER CHIMNEY PIPE
- 603 SEWER CLEANOUT
- 606 PRE-CAST CONCRETE MH, ECCENTRIC
- 607 PRE-CAST CONCRETE MH, CONCENTRIC
- 608 MANHOLE FRAMES AND COVERS
- 610 PRECAST RECT. SHALLOW MANHOLE
- 611 RECTANGULAR MANHOLE FRAME AND COVER
- 612 PAVING DETAIL AROUND MANHOLE IN UNPAVED AREA

### WATER

- 700 WATER METER INSTALLATION
- 701 FIRE HYDRANT INSTALLATION
- 702 FIRE HYDRANT INSTALLATION (ALTERNATE)
- 703 VALVE BOX, FRAME AND COVER

### GEOMETRICS

- 800 CUL-DE-SAC
- 800A OFFSET CUL-DE-SAC
- 801 KNUCKLE
- 802 FRONTAGE ROAD INTERSECTION
- 803 PRIVATE ROAD CONNECTION (RURAL AREA)
- 805 PROPERTY LINE CORNER CUT BACK, CURB RETURN RADIUS
- 806 ENTRY STREET 50' IMP/80' R/W
- 810 BARRICADE
- 812 MULTIPLE MAILBOX INSTALLATION FOR NEW SIDEWALK
- 813 MULTIPLE MAILBOX INSTALLATION FOR EXISTING SIDEWALK
- 814 BUS TURNOUT

### GEOMETRICS (CONTINUED)

- 817 UNDERGROUND UTILITY LOCATIONS
- 818 UTILITY TRENCH BACKFILL
- 819 LOCATION OF CABLE TV DUCTS AT STREET INTERSECTIONS
- 820 FIXED OBJECT PLACEMENT FOR ROADWAYS WITHOUT CURBS
- 821 INTERSECTION SIGHT DISTANCE

### MONUMENTING

- 900 TIE-OUT STANDARDS
- 901 STREET CENTERLINE MONUMENT
- 903 TYPE "B" MONUMENT

### LIGHTING

- 1000 STREET LIGHTING

### ROADWAY LANDSCAPING

- 1101 TREE SETBACKS AT CORNER CUT-BACKS AND DRIVEWAYS
- 1102 TREE STAKING DETAIL
- 1103 BACKFLOW PREVENTION DEVICE INSTALLATION

### TRAFFIC

- 1200 IISNS MAST ARM DETAIL
- 1201 IISNS DETAIL
- 1202 TRAFFIC SIGNAL DETAIL
- 1205 VIDEO/RADAR DETECTION DETAIL
- 1206 LOOP DETECTOR DETAIL
- 1207 DETECTION INPUT ASSIGNMENTS
- 1210 STRIPING DETAILS AND CONSTRUCTION NOTES
- 1211 CROSSWALK AND LIMIT LINE LAYOUT DETAIL
- 1215 SOLAR POWERED FLASHING BEACON
- 1216 SOLAR POWERED RADAR SPEED FEEDBACK SIGN - LOCAL ROAD
- 1217 SOLAR POWERED RADAR SPEED FEEDBACK SIGN - HIGHWAY
- 1220 STREET NAME SIGN (CURB TO CURB WIDTH GREATER THAN 60')
- 1221 STREET NAME SIGN - (CURB TO CURB WIDTH LESS THAN OR EQUAL TO 60')
- 1222 SIGN POST INSTALLATION
- 1223 NO PARKING SIGN RV'S / TRAILERS
- 1225 ADVANCE STREET NAME SIGN

**A**

AB	AGGREGATE BASE
ABBR	ABBREVIATION
ABN	ABANDON
AC	ASPHALT CONCRETE
ACB	ASPHALT CONCRETE BASE
ADA	AMERICANS WITH DISABILITIES ACT
AHD	AHEAD
ALT	ALTERNATE
ALUM	ALUMINUM
AMP	AMPERE
APPROX	APPROXIMATE
ARHM	ASPHALT-RUBBER-HOT-MIX
AS	AGGREGATE SUBBASE
AST	ABOVE-GROUND STORAGE TANK
ATC	ADVANCED TRANSPORTATION CONTROLLER
AVE	AVENUE
@	AT

**B**

BC	BEGIN HORIZONTAL CURVE
BCR	BEGIN CURB RETURN
BEG	BEGIN
BLDG	BUILDING
BLVD	BOULEVARD
BM	BENCH MARK
BMP	BEST MANAGEMENT PRACTICE
BOS	BOARD OF SUPERVISORS
BOT	BOTTOM
BOW	BACK OF WALK
BR	BRIDGE
BRG	BEARING
BVC	BEGIN VERTICAL CURVE

**C**

C/G	CURB AND GUTTER
CAB	CRUSHED AGGREGATE BASE
CAP	CORRUGATED ALUMINUM PIPE
CB	CATCH BASIN
CBC	CATCH BASIN CLEANOUT
CBI	CATCH BASIN INSERT
CF	CURB FACE
CIP	CAST IRON PIPE
CLF	CHAIN LINK FENCE
CLR	CLEAR, CLEARANCE
CM	CULVERT MARKER
CMD	CRUSHED MISCELLANEOUS BASE
CONC	CONCRETE
CONST	CONSTRUCT, CONSTRUCTION
CONT	CONTINUOUS
C.R.	CORNER RADIUS
CS	CROSS SLOPE
CULV	CULVERT
CV	CHECK VALVE
CW	CROSS WALK
Ⓞ	CENTERLINE

**D**

DET	DETAIL, DETOUR
D.F.	DOUGLAS FIR
DG	DECOMPOSED GRANITE
DI	DRAINAGE INLET
DIA	DIAMETER
DIST	DISTANCE
DR	DRIVE
DWY	DRIVEWAY

**E**

EC	END HORIZONTAL CURVE
ECR	END CURB RETURN
EG	EDGE OF GUTTER
EGL	ENERGY GRADE LINE
EIR	ENVIRONMENTAL IMPACT RECORD
EL	ELEVATION
ELEV	ELEVATION
E/O	EAST OF
EP	EDGE OF PAVEMENT
EQUIV	EQUIVALENT
ES	EDGE OF PAVED SHOULDER
ETC	ETCETERA
ETW	EDGE OF TRAVELED WAY
EVC	END OF VERTICAL CURVE
EXIST, (E)	EXISTING
EXP	EXPANSION, EXPIRATION
EXPY	EXPRESSWAY

**F**

FEBT	FACING EASTBOUND TRAFFIC
FDY	FOUNDRY
FG	FINISHED GRADE
FH	FIRE HYDRANT
FL	FLOW LINE
FNBT	FACING NORTHBOUND TRAFFIC
FS	FINISHED SURFACE
FSBT	FACING SOUTHBOUND TRAFFIC
FT	FEET
FTCD	FULL TRASH CAPTURE DEVICE
FWBT	FACING WESTBOUND TRAFFIC
FW	FACE OF WALL
FWY	FREEWAY

**G**

GA	GAUGE
GALV	GALVANIZED
GB	GRADE BREAK
GM	GAS METER
GR	GRADE
GS	GRADED SHOULDER
GTR	GUTTER

**H**

HGL HYDRAULIC GRADE LINE  
 HMA HOT MIX ASPHALT  
 HORIZ HORIZONTAL  
 HPG HIGH PRESSURE GAS  
 HW HEADWALL  
 HWY HIGHWAY

**I**

ID INSIDE DIAMETER / IDENTIFICATION  
 IN INCH  
 INV INVERT  
 IP IRON PIPE  
 IISNS INTERNALLY ILLUMINATED  
 STREET NAME SIGN

**J**

JS JUNCTION STRUCTURE  
 JT JOINT

**L**

L LENGTH  
 LBS POUNDS  
 LC LOWER CASE  
 LF LINEAR FOOT  
 LN LANE  
 LOC LOCATION  
 LOL LAYOUT LINE  
 LONG LONGITUDE  
 LONGIT LONGITUDINAL  
 LP LAMP POST  
 LS LANSCAPING, LUMP SUM  
 LT LEFT  
 LTT LEFT TURN

**M**

MA MAST ARM  
 MAINT MAINTENANCE  
 MAX MAXIMUM  
 MBGR METAL BEAM GUARD RAILING  
 MED MEDIAN  
 MH MANHOLE  
 MIN MINIMUM  
 MISC MISCELLANEOUS  
 MM MILE MARKER  
 MOD MODIFIED, MODIFY  
 MPH MILES PER HOUR  
 MT MOUNTAIN, MOUNT

**N**

N NEUTRAL  
 NB NORTHBOUND  
 No. NUMBER  
 NOM NOMINAL  
 N/O NORTH OF  
 NTS NOT TO SCALE

**O**

OC OVERCROSSING, ON CENTER  
 OD OUTSIDE DIAMTER  
 OG ORIGINAL GROUND  
 OH OVERHEAD

**P**

PB PULL BOX  
 PEC PHOTO ELECTRIC CELL  
 PED PEDESTRIAN  
 PEU PHOTO ELECTRIC UNIT  
 PD PRIVATE DRAIN  
 PG PROFILE GRADE  
 PI POINT OF INTERSECTION  
 P/L PROPERTY LINE  
 PCC PORTLAND CEMENT CONCRETE  
 POC POINT OF HORIZONTAL CURVE,  
 PEDESTRIAN OVERCROSSING  
 PP POWER POLE  
 PRC POINT OF REVERSE CURVE  
 PS&E PLANS, SPECIFICATIONS AND  
 ESTIMATES  
 PVMT PAVEMENT

**Q**

QTY QUANTITY

**R**

R RADIUS  
 RC REVERSE CURVE  
 RCB REINFORCED CONCRETE BOX  
 RCP REINFORCED CONCRETE PIPE  
 RD ROAD  
 RDWY ROADWAY  
 REAS RUBBERIZED EMULSION ASPHALT  
 SLURRY  
 REINF REINFORCEMENT  
 REL, RELOCATE  
 RELOC  
 REQ REQUIRED  
 RET RETAINING  
 REV REVISED, REVISION  
 RPM RAISED PAVEMENT MARKER  
 RR RAILROAD  
 RS RAMP SLOPE  
 RT RIGHT  
 RTT RIGHT TURN  
 RTE ROUTE  
 RV RECREATIONAL VEHICLES  
 RW RETAINING WALL  
 R/W RIGHT OF WAY

**S**

S	SOUTH
SALV	SALVAGE
SB	SOUTHBOUND
SCH, SCHED	SCHEDULE
SD	STORM DRAIN
SEC	SECTION
SEG	SUPER ENGINEERING GRADE
SEP	SEPARATION
SG	SUBGRADE
SHLD	SHOULDER
SHT	SHEET
S	STATION LINE
SGS	STREET & GUTTER SLOPE
SO	SOUTH OF
SPEC	SPECIFICATION
SR	STATE ROUTE
ST	STREET
STA	STATION
STD	STANDARD
STR	STRUCTURE, STRAIGHT
SURF	SURFACING
SW	SIDEWALK, SOUND WALL

**T**

TC	TOP OF CURB
TD	TOP OF DIKE
TEL	TELEPHONE
TEMP	TEMPORARY
TG	TOP OF GRADE
TOT	TOTAL
TRANS	TRANSITION
TS	TRAFFIC SIGNAL, TRANSITION SLOPE
TV	TELEVISION
TYP	TYPICAL

**U**

UC	UNDERCROSSING, UPPER CASE
UD	UNDERDRAIN

**V**

VAR	VARIABLE, VARIES
VC	VERTICAL CURVE
VCP	VITRIFIED CLAY PIPE
VERT	VERTICAL
VOL	VOLUME

**W**

W	WEST
W/	WITH
WA	WIDTH A
WB	WESTBOUND
WHT	WHITE
W/O	WEST OF
WV	WATER VALVE
WW	WINGWALL

**X**

X SEC	CROSS SECTION
X-WALK	CROSSWALK
XING	CROSSING

**Y**

YR	YEAR
YRS	YEARS

**MISCELLANEOUS**

2:1	2 HORIZONTAL TO 1 VERTICAL
-----	----------------------------

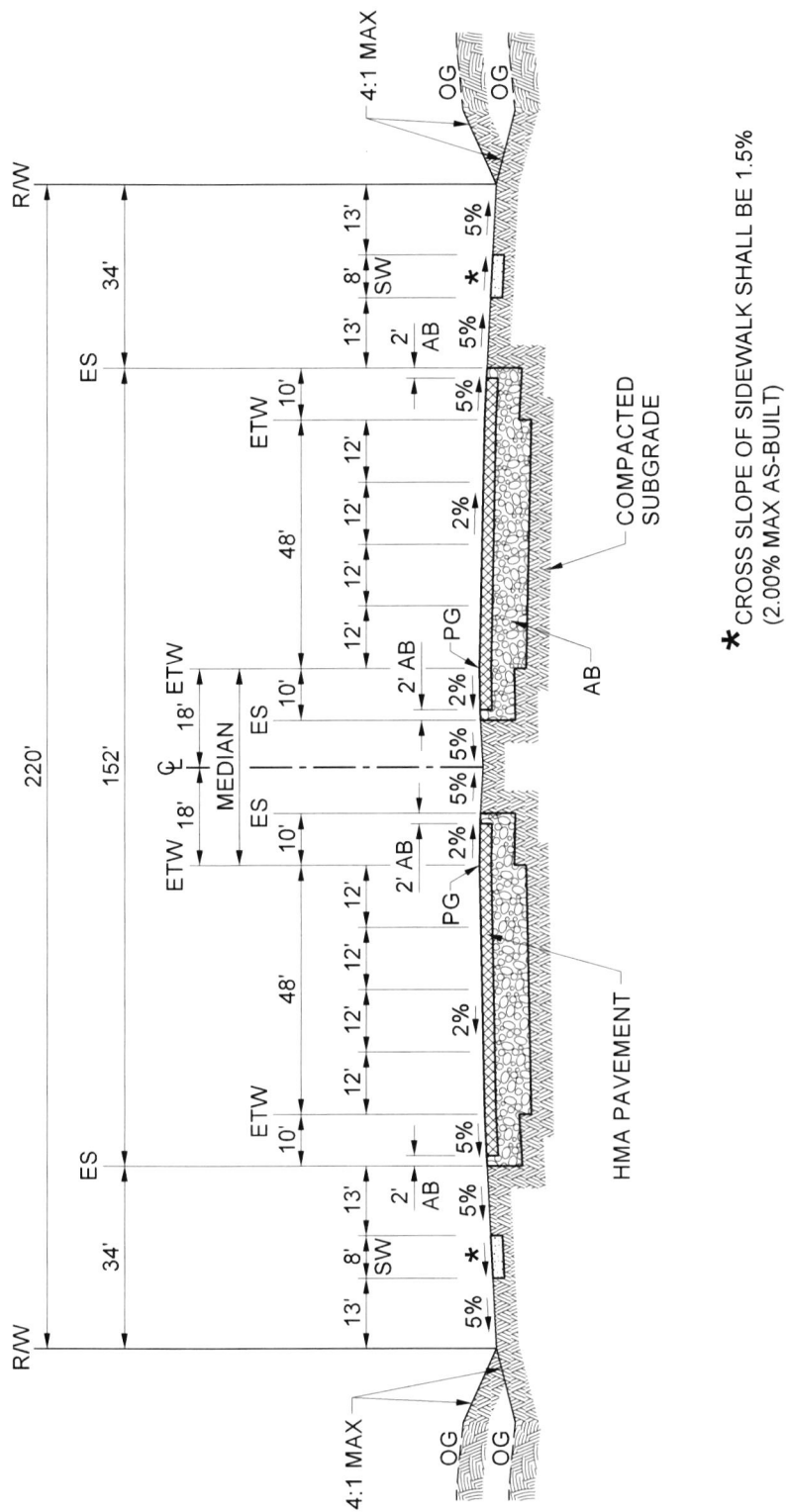

\* CROSS SLOPE OF SIDEWALK SHALL BE 1.5% (2.00% MAX AS-BUILT)

**NOTES:**

1. THICKNESS OF AB AND HMA (FOR SHOULDER, AND FOR TRAVELED WAY) TO BE DETERMINED BY SOIL TEST AT TIME OF GRADING OPERATIONS.
2. MINIMUM PAVING THICKNESS PER SPECIFICATIONS SECTION 8.07 OF THIS ORDINANCE.
3. IMPROVEMENTS TO STATE HIGHWAYS SHALL CONFORM TO CALTRANS DESIGN STANDARDS AND POLICIES. RIGHT OF WAY MAY VARY PER THE REQUIREMENTS OF CALTRANS POLICY.
4. SIDEWALKS SHALL BE IMPROVED AS DETERMINED BY THE DIRECTOR OF TRANSPORTATION.
5. SEE SHEET 2 OF 2 FOR INTERSECTION CONFIGURATION AND TRANSITION.

NOT TO SCALE

PREPARED UNDER THE SUPERVISION OF:

*Mark Lancaster*  
 DIRECTOR OF TRANSPORTATION  
 MARK LANCASTER, P.E.  
 11/30/22  
 DATE

REVISION	DESCRIPTION	MARK	DATE	APPROVED



COUNTY OF RIVERSIDE

**8-LANE EXPRESSWAY  
 152' IMPROVEMENT  
 (220' R/W)**

**STANDARD No. 81 (1 OF 2)**

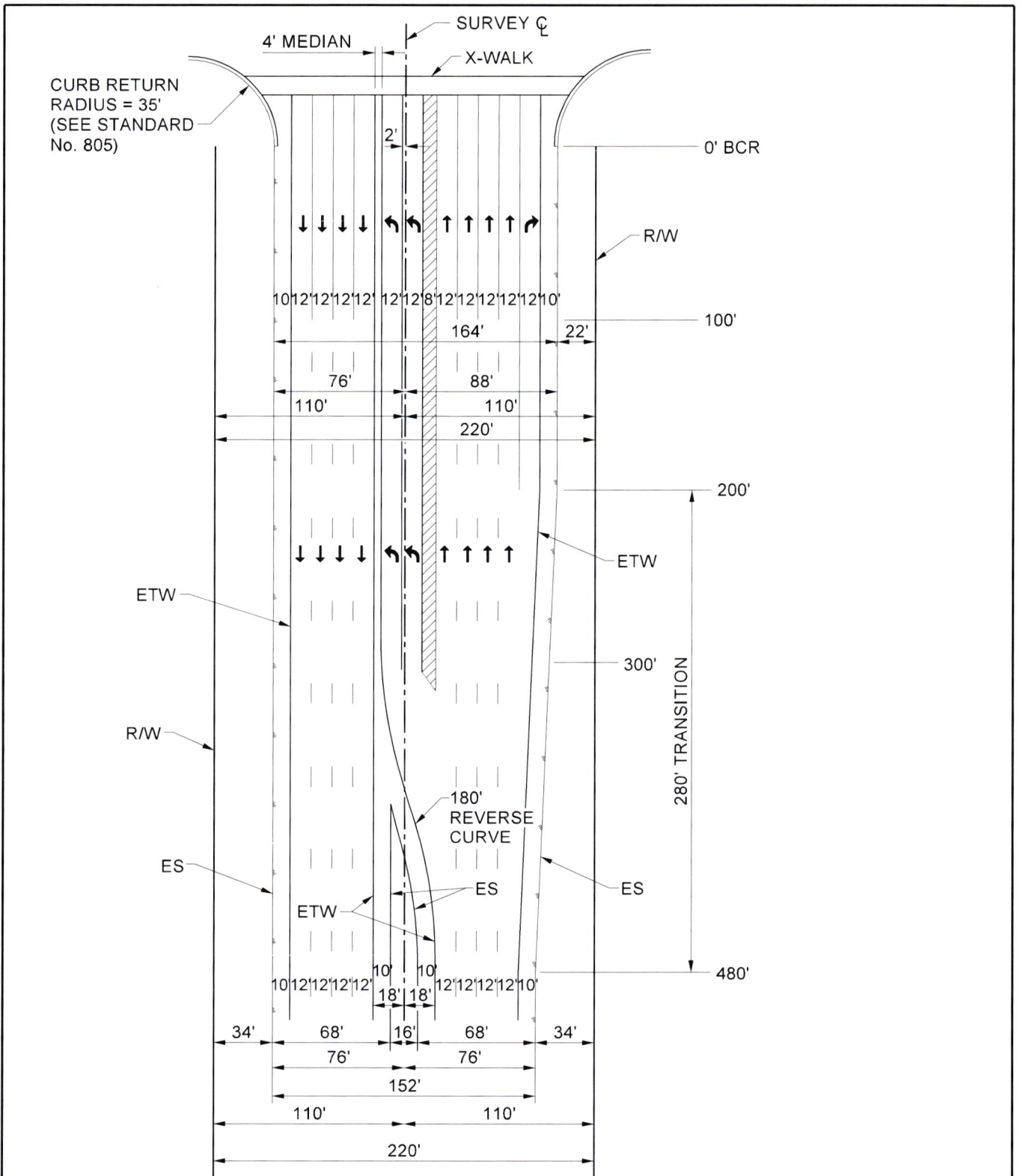

NOT TO SCALE

PREPARED UNDER THE SUPERVISION OF:

*Mark Lancaster*  
 DIRECTOR OF TRANSPORTATION  
 MARK LANCASTER, P.E.

11/30/22  
 DATE



COUNTY OF RIVERSIDE

**8-LANE EXPRESSWAY  
 152' IMPROVEMENT  
 (220' R/W)**

STANDARD No. 81 (2 OF 2)

REVISION DESCRIPTION	MARK	DATE	APPROVED

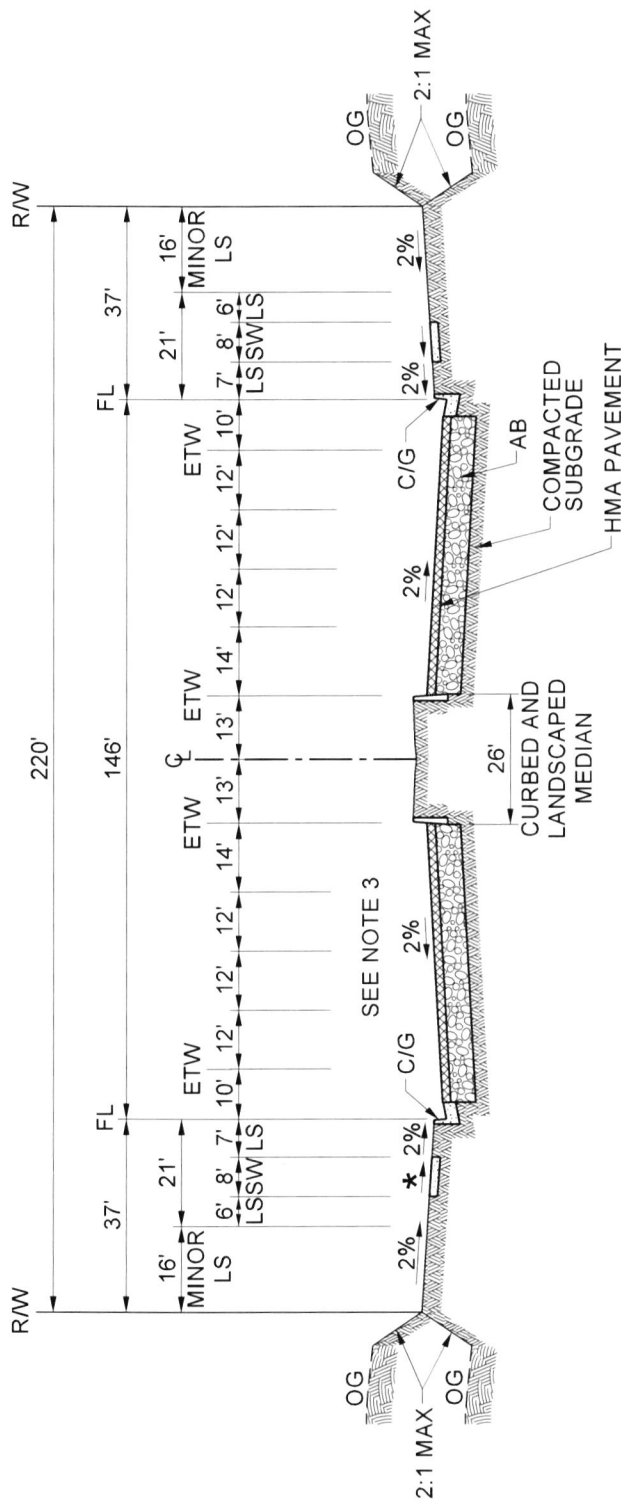

\* CROSS SLOPE OF SIDEWALK SHALL BE 1.5% (2.00% MAX AS-BUILT)

**NOTES:**

1. THICKNESS OF AB AND HMA (FOR SHOULDER, AND FOR TRAVELED WAY) TO BE DETERMINED BY SOIL TEST AT TIME OF GRADING OPERATIONS.
2. MINIMUM PAVING THICKNESS PER SPECIFICATIONS SECTION 8.07 OF THIS ORDINANCE.
3. SEE STANDARD No. 113 FOR LANDSCAPED MEDIAN REQUIREMENTS, INCLUDING MEDIAN CURB.
4. IMPROVEMENTS TO STATE HIGHWAYS SHALL CONFORM TO CALTRANS DESIGN STANDARDS AND POLICIES. RIGHT OF WAY MAY VARY PER THE REQUIREMENTS OF CALTRANS POLICY.
5. SEE SHEET 2 OF 2 FOR INTERSECTION CONFIGURATION AND TRANSITION.

NOT TO SCALE

NOTE: THIS WAS NUMBERED STANDARD No. 86 PRIOR TO 2023

PREPARED UNDER THE SUPERVISION OF:

*Mark Lancaster* 11/30/22  
 DIRECTOR OF TRANSPORTATION DATE  
 MARK LANCASTER, P.E.

REVISION DESCRIPTION	MARK	DATE	APPROVED



COUNTY OF RIVERSIDE

**8-LANE EXPRESSWAY  
 146' IMPROVEMENT  
 (220' R/W)**

**STANDARD No. 82 (1 OF 2)**



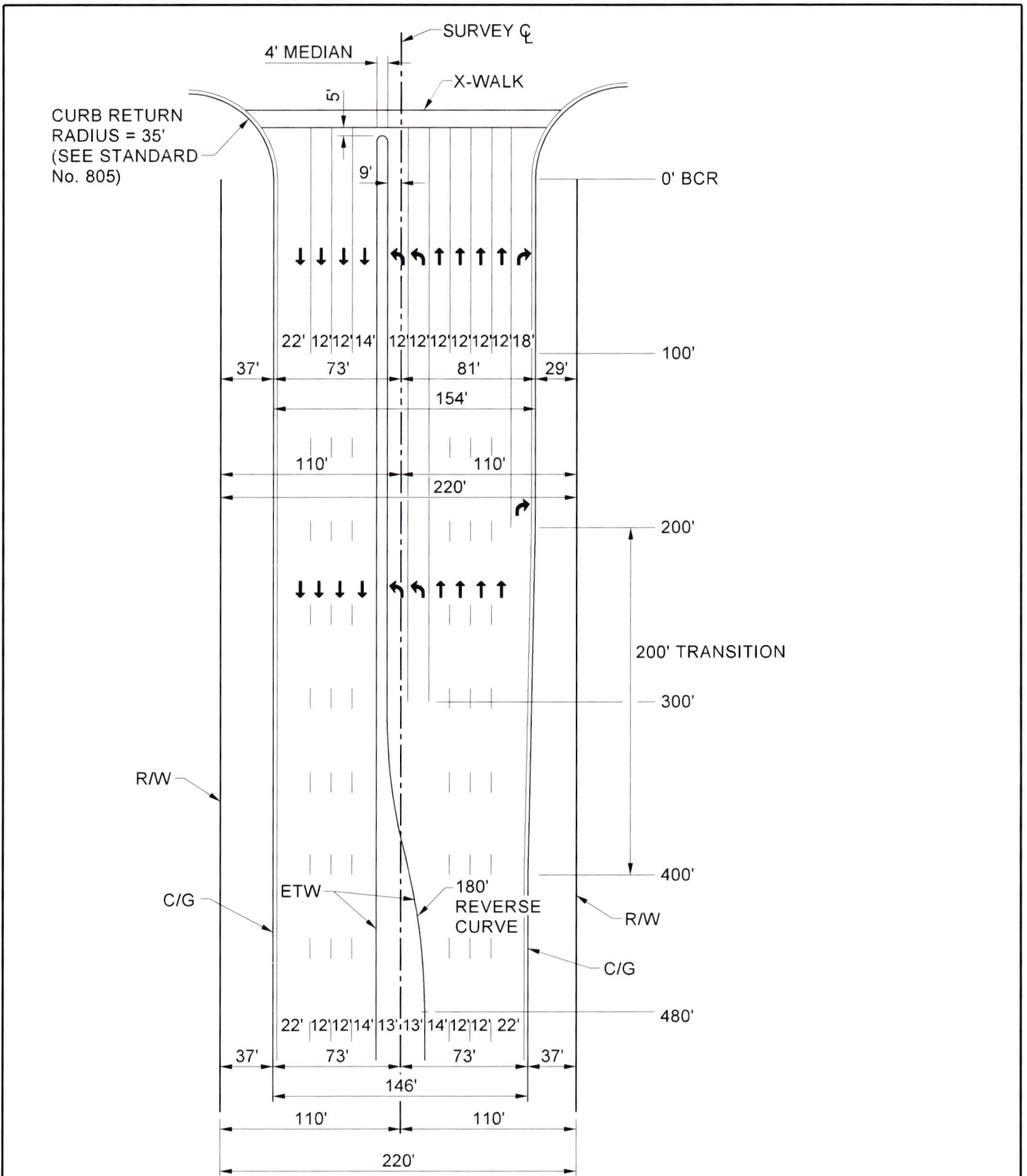

NOT TO SCALE

NOTE: THIS WAS NUMBERED STANDARD No. 86 PRIOR TO 2023

PREPARED UNDER THE SUPERVISION OF:

*Mark Lancaster*

11/30/22  
DATE

DIRECTOR OF TRANSPORTATION  
MARK LANCASTER, P.E.



COUNTY OF RIVERSIDE

**8-LANE EXPRESSWAY  
146' IMPROVEMENT  
(220' R/W)**

STANDARD No. 82 (2 OF 2)

REVISION	DESCRIPTION	MARK	DATE	APPROVED

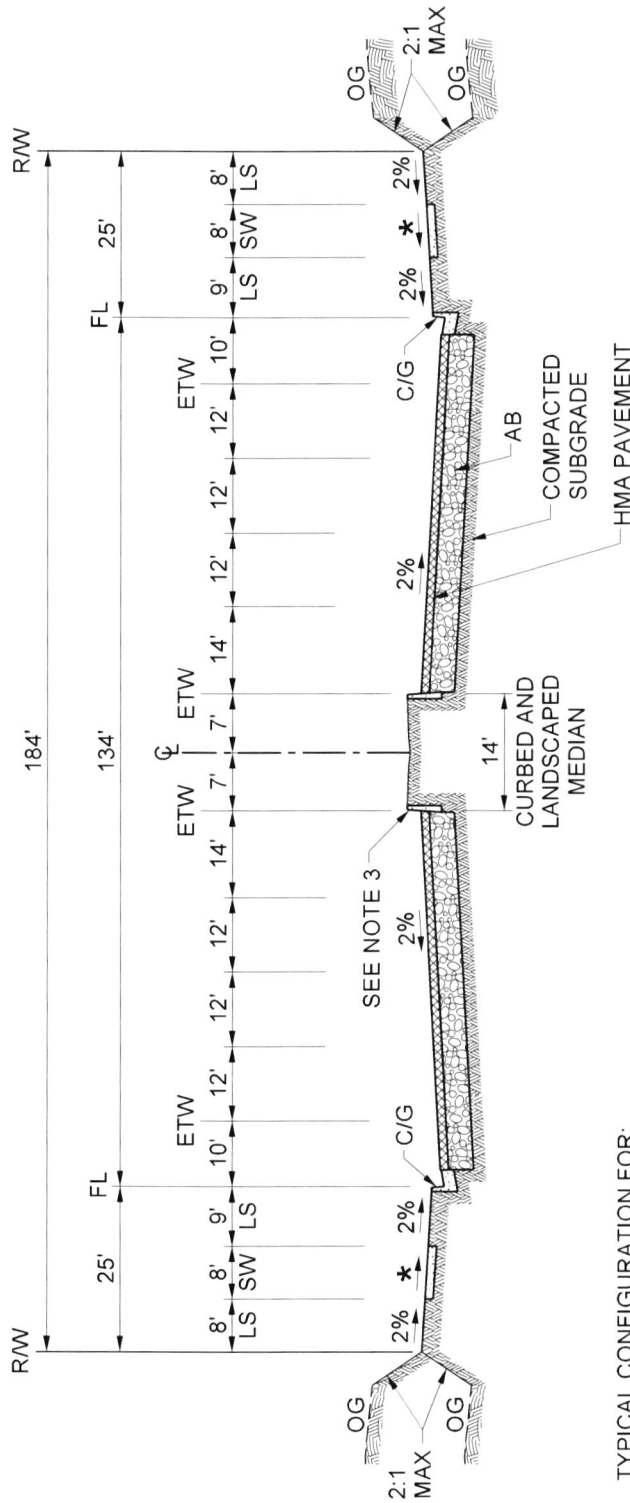

TYPICAL CONFIGURATION FOR:

1. SR-74 FROM BRIGGS RD EAST TO SR-79 / WARREN RD

\* CROSS SLOPE OF SIDEWALK SHALL BE 1.5% (2.00% MAX AS-BUILT)

**NOTES:**

1. THICKNESS OF AB AND HMA (FOR SHOULDER, AND FOR TRAVELED WAY) TO BE DETERMINED BY SOIL TEST AT TIME OF GRADING OPERATIONS.
2. MINIMUM PAVING THICKNESS PER SPECIFICATIONS SECTION 8.07 OF THIS ORDINANCE.
3. SEE STANDARD No. 113 FOR LANDSCAPED MEDIAN REQUIREMENTS, INCLUDING MEDIAN CURB.
4. IMPROVEMENTS TO STATE HIGHWAYS SHALL CONFORM TO CALTRANS DESIGN STANDARDS AND POLICIES. RIGHT OF WAY MAY VARY PER THE REQUIREMENTS OF CALTRANS POLICY.
5. SEE SHEET 2 OF 2 FOR INTERSECTION CONFIGURATION AND TRANSITION.

NOT TO SCALE

NOTE: THIS WAS NUMBERED STANDARD No. 87 PRIOR TO 2023

PREPARED UNDER THE SUPERVISION OF:

*Mark Lancaster*  
 DIRECTOR OF TRANSPORTATION  
 MARK LANCASTER, P.E.

11/30/22  
 DATE

REVISION	DESCRIPTION	MARK	DATE	APPROVED



COUNTY OF RIVERSIDE

**8-LANE EXPRESSWAY  
 134' IMPROVEMENT  
 (184' R/W)**

**STANDARD No. 83 (1 OF 2)**

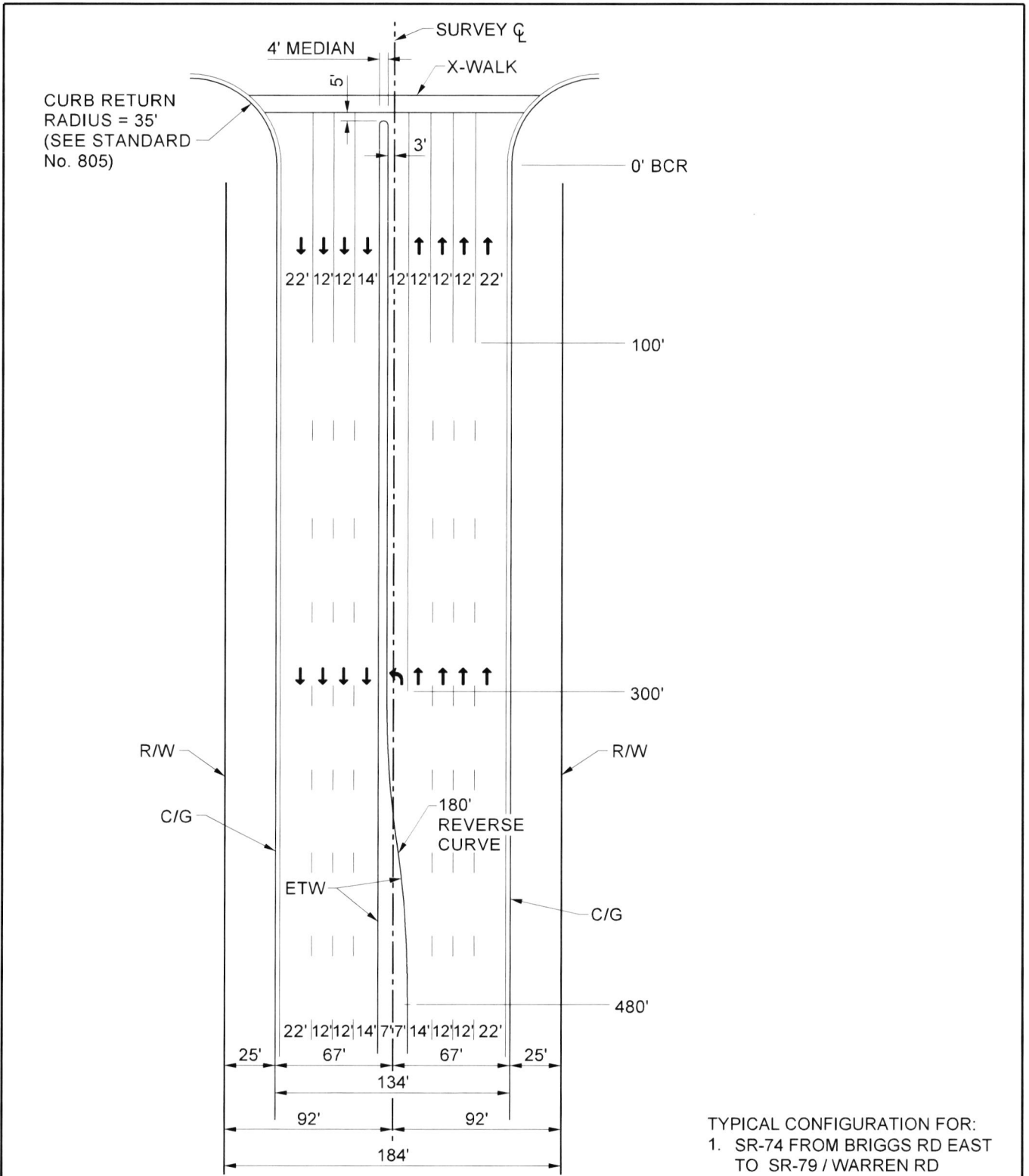

TYPICAL CONFIGURATION FOR:  
 1. SR-74 FROM BRIGGS RD EAST TO SR-79 / WARREN RD

NOT TO SCALE

NOTE: THIS WAS NUMBERED STANDARD No. 87 PRIOR TO 2023

PREPARED UNDER THE SUPERVISION OF:

*Mark Lancaster*

11/30/22  
DATE

DIRECTOR OF TRANSPORTATION  
 MARK LANCASTER, P.E.



COUNTY OF RIVERSIDE

**8-LANE EXPRESSWAY  
 134' IMPROVEMENT  
 (184' R/W)**

STANDARD No. 83 (2 OF 2)

REVISION DESCRIPTION	MARK	DATE	APPROVED

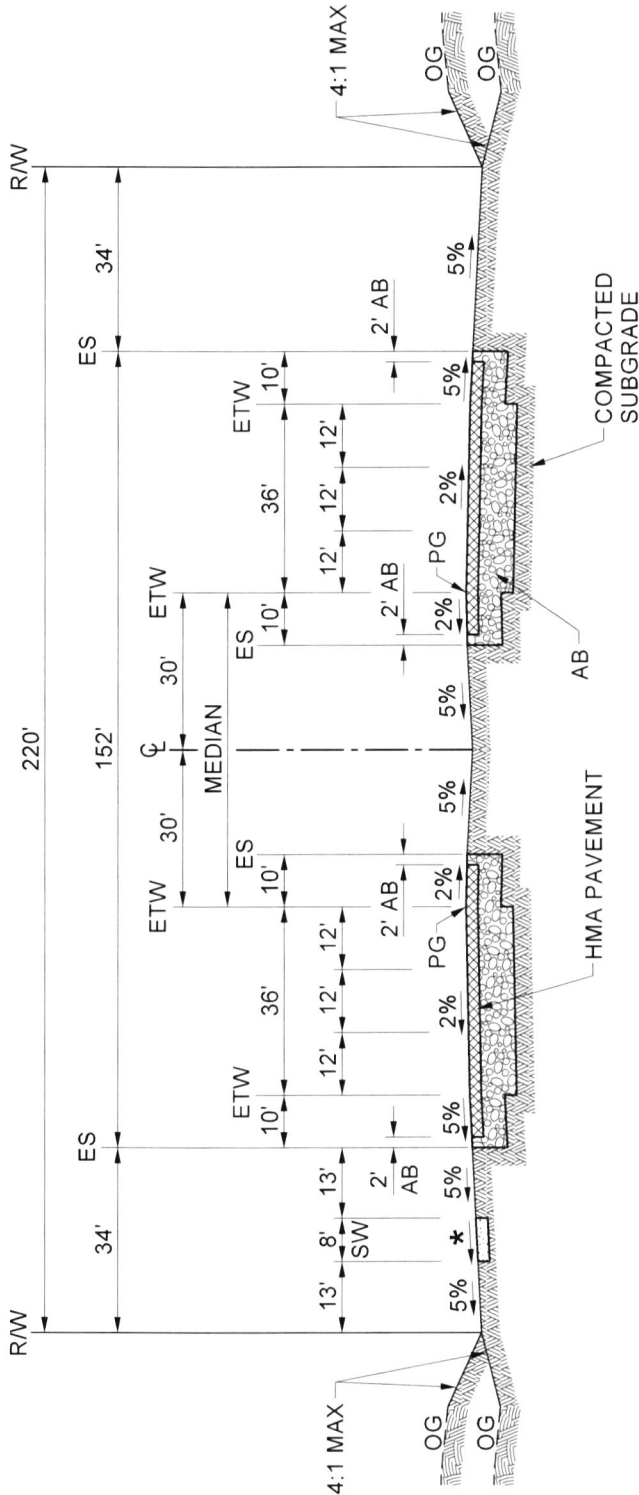

\* CROSS SLOPE OF SIDEWALK SHALL BE 1.5% (2.00% MAX AS-BUILT)

- TYPICAL CONFIGURATION FOR:
1. WINCHESTER RD (SR 79) FROM 1/2 MILE NORTH OF KELLER RD, NORTH TO I-10
  2. CAJALCO RD / RAMONA EXPY FROM I-15, EAST TO SR-74

**NOTES:**

1. THICKNESS OF AB AND HMA (FOR SHOULDER, AND FOR TRAVELED WAY) TO BE DETERMINED BY SOIL TEST AT TIME OF GRADING OPERATIONS.
2. MINIMUM PAVING THICKNESS PER SPECIFICATIONS SECTION 8.07 OF THIS ORDINANCE.
3. IMPROVEMENTS TO STATE HIGHWAYS SHALL CONFORM TO CALTRANS DESIGN STANDARDS AND POLICIES. RIGHT OF WAY MAY VARY PER THE REQUIREMENTS OF CALTRANS POLICY.
4. CONCRETE CURB, GUTTER, AND SIDEWALKS SHALL BE IMPROVED AS DETERMINED BY THE DIRECTOR OF TRANSPORTATION.
5. SEE SHEET 2 OF 2 FOR INTERSECTION CONFIGURATION AND TRANSITION.

NOT TO SCALE

NOTE: THIS WAS NUMBERED STANDARD No. 82 PRIOR TO 2023

PREPARED UNDER THE SUPERVISION OF:

*Mark Lancaster*  
 DIRECTOR OF TRANSPORTATION  
 MARK LANCASTER, P.E.  
 11/30/22  
 DATE



COUNTY OF RIVERSIDE

**6-LANE EXPRESSWAY  
 152' IMPROVEMENT  
 (220' R/W)**

STANDARD No. 84 (1 of 2)

REVISION DESCRIPTION	MARK	DATE	APPROVED

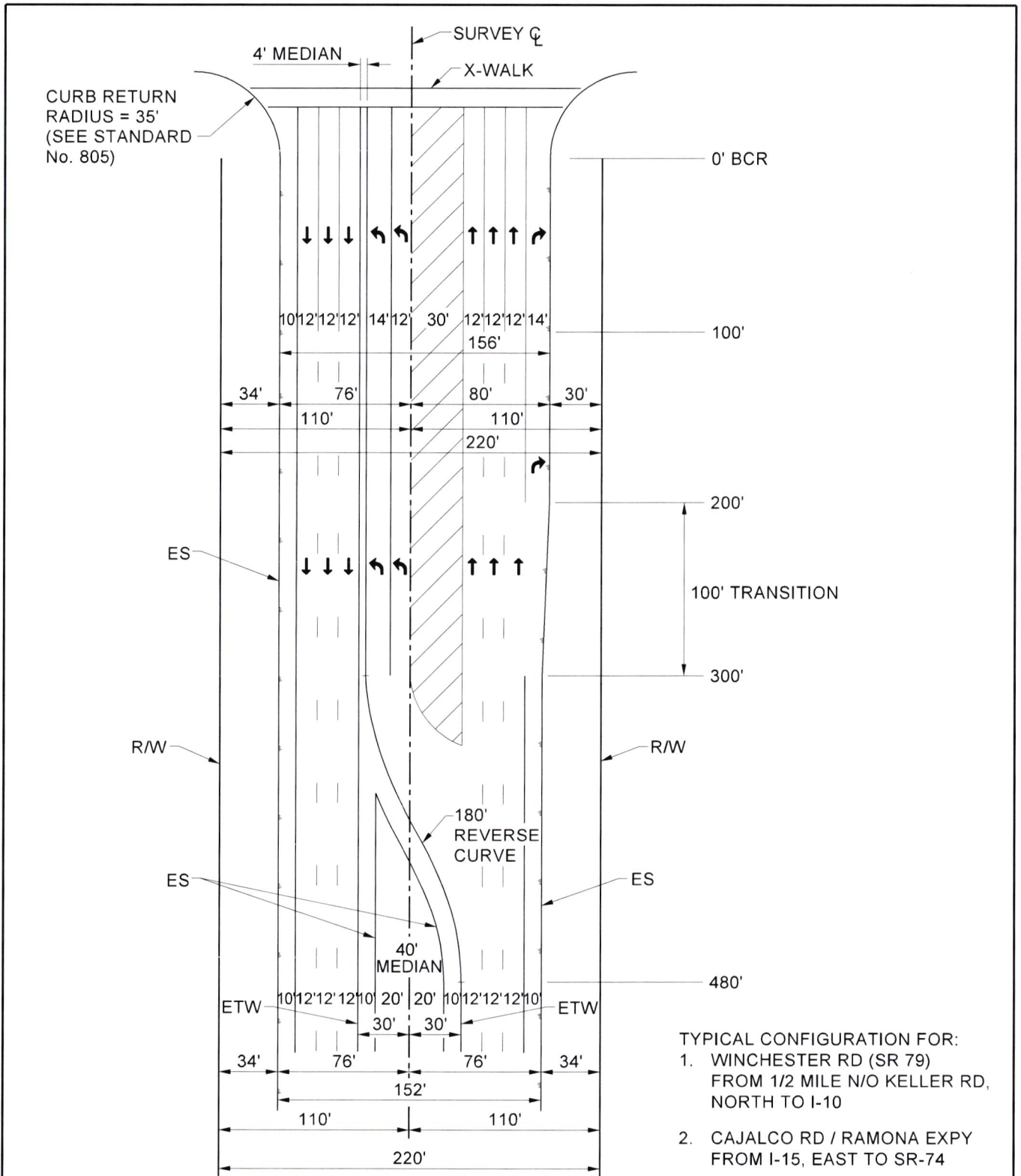

- TYPICAL CONFIGURATION FOR:
1. WINCHESTER RD (SR 79) FROM 1/2 MILE N/O KELLER RD, NORTH TO I-10
  2. CAJALCO RD / RAMONA EXPY FROM I-15, EAST TO SR-74

NOT TO SCALE

NOTE: THIS WAS NUMBERED STANDARD No. 82 PRIOR TO 2023

PREPARED UNDER THE SUPERVISION OF:

*Mark Lancaster*

11/30/22  
DATE

DIRECTOR OF TRANSPORTATION  
MARK LANCASTER, P.E.



COUNTY OF RIVERSIDE

**6-LANE EXPRESSWAY  
152' IMPROVEMENT  
(220' R/W)**

**STANDARD No. 84 (2 of 2)**

REVISION	DESCRIPTION	MARK	DATE	APPROVED

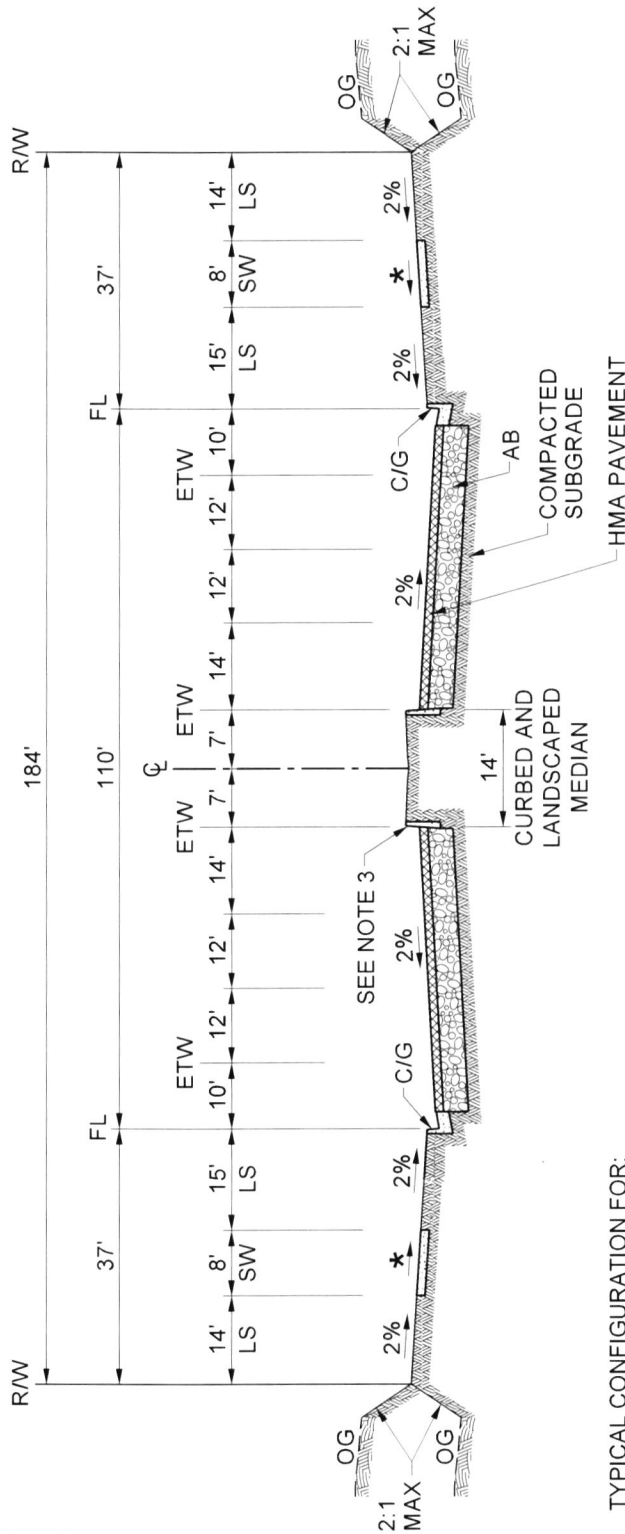

TYPICAL CONFIGURATION FOR:

1. WINCHESTER RD (SR 79) FROM I-15, NORTH TO 1/2 MILE NORTH OF KELLER RD
2. SR-74 FROM I-15, EAST TO KEYSTONE DR (WESTERN CITY LIMITS OF PERRIS)

\* CROSS SLOPE OF SIDEWALK SHALL BE 1.5% (2.00% MAX AS-BUILT)

NOTES:

1. THICKNESS OF AB AND HMA (FOR SHOULDER, AND FOR TRAVELED WAY) TO BE DETERMINED BY SOIL TEST AT TIME OF GRADING OPERATIONS.
2. MINIMUM PAVING THICKNESS PER SPECIFICATIONS SECTION 8.07 OF THIS ORDINANCE.
3. SEE STANDARD No. 113 FOR LANDSCAPED MEDIAN REQUIREMENTS, INCLUDING MEDIAN CURB.
4. IMPROVEMENTS TO STATE HIGHWAYS SHALL CONFORM TO CALTRANS DESIGN STANDARDS AND POLICIES. RIGHT OF WAY MAY VARY PER THE REQUIREMENTS OF CALTRANS POLICY.
5. SEE SHEET 2 OF 2 FOR INTERSECTION CONFIGURATION AND TRANSITION.

NOT TO SCALE

NOTE: THIS WAS NUMBERED STANDARD No. 83 PRIOR TO 2023

PREPARED UNDER THE SUPERVISION OF:

*Mark Lancaster*  
 DIRECTOR OF TRANSPORTATION  
 MARK LANCASTER, P.E.  
 11/30/22  
 DATE

REVISION	DESCRIPTION	MARK	DATE	APPROVED



COUNTY OF RIVERSIDE

**6-LANE EXPRESSWAY  
 110' IMPROVEMENT  
 (184' R/W)**

**STANDARD No. 85 (1 OF 2)**

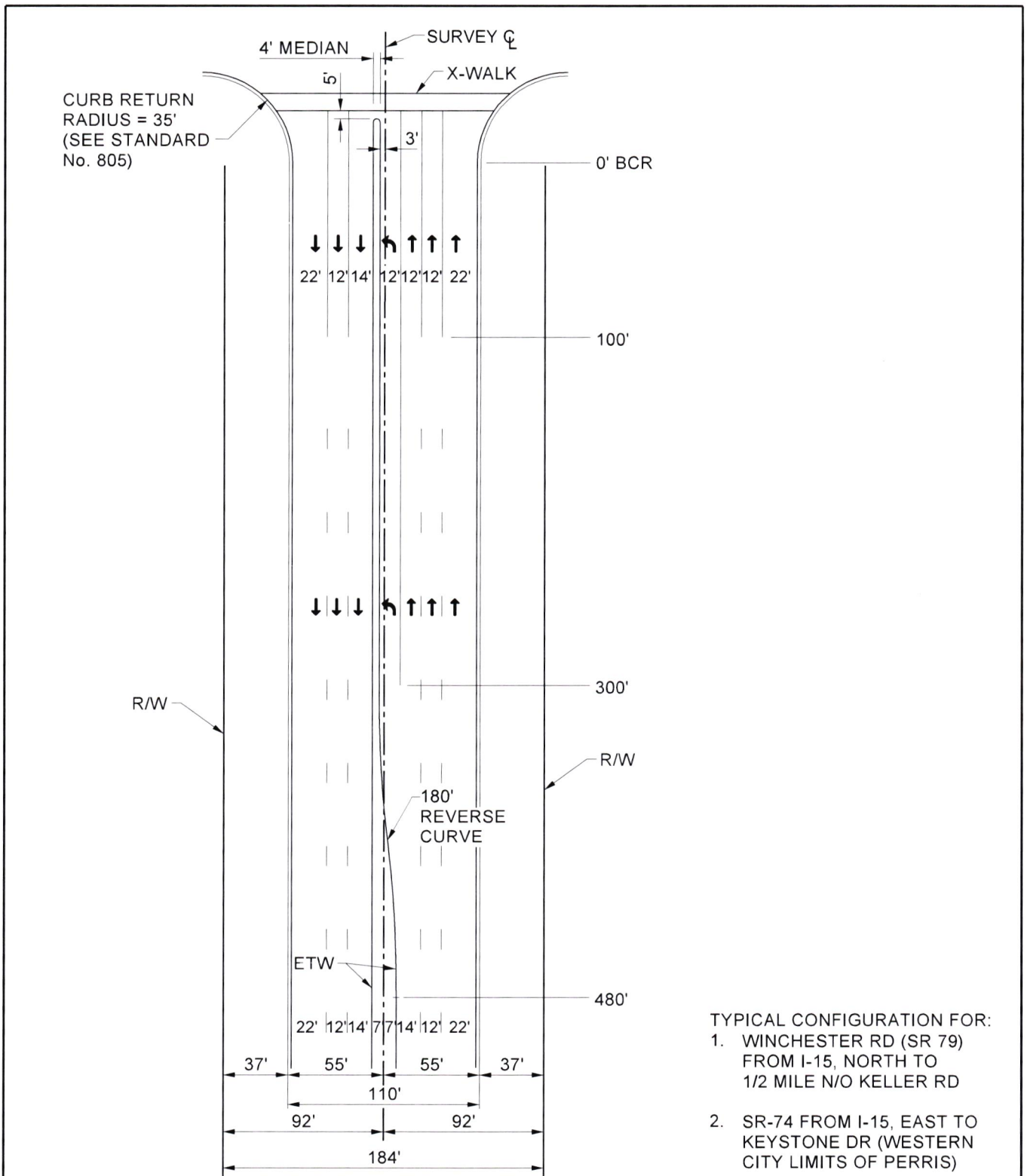

- TYPICAL CONFIGURATION FOR:
1. WINCHESTER RD (SR 79) FROM I-15, NORTH TO 1/2 MILE N/O KELLER RD
  2. SR-74 FROM I-15, EAST TO KEYSTONE DR (WESTERN CITY LIMITS OF PERRIS)

NOT TO SCALE

NOTE: THIS WAS NUMBERED STANDARD No. 83 PRIOR TO 2023

PREPARED UNDER THE SUPERVISION OF:

*Mark Lancaster* 11/30/22  
 DIRECTOR OF TRANSPORTATION DATE  
 MARK LANCASTER, P.E.



COUNTY OF RIVERSIDE

**6-LANE EXPRESSWAY  
 110' IMPROVEMENT  
 (184' R/W)**

REVISION	DESCRIPTION	MARK	DATE	APPROVED

STANDARD No. 85 (2 OF 2)

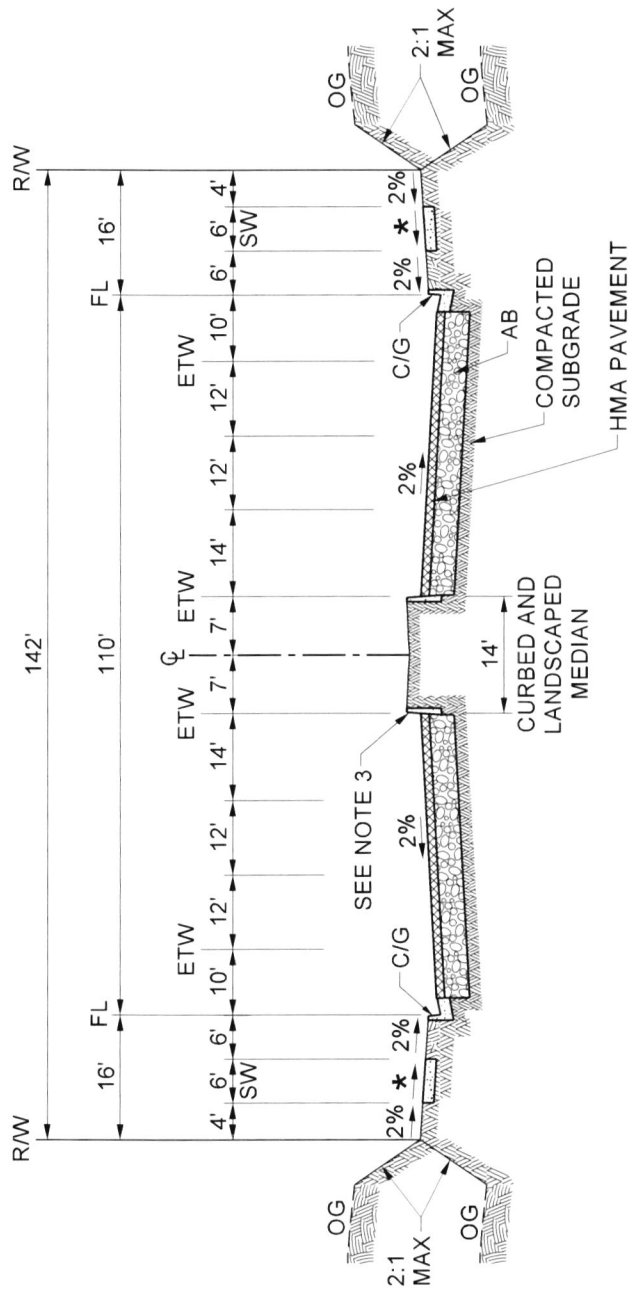

\* CROSS SLOPE OF SIDEWALK SHALL BE 1.5% (2.00% MAX AS-BUILT)

TYPICAL CONFIGURATION FOR:  
 1. SR 79 (SOUTH) FROM 1200' EAST OF BUTTERFIELD STAGE RD EAST TO APPROX 500' EAST OF PAUBA RD

**NOTES:**

1. THICKNESS OF AB AND HMA (FOR SHOULDER, AND FOR TRAVELED WAY) TO BE DETERMINED BY SOIL TEST AT TIME OF GRADING OPERATIONS.
2. MINIMUM PAVING THICKNESS PER SPECIFICATIONS SECTION 8.07 OF THIS ORDINANCE.
3. SEE STANDARD No. 113 FOR LANDSCAPED MEDIAN REQUIREMENTS, INCLUDING MEDIAN CURB.
4. IMPROVEMENTS TO STATE HIGHWAYS SHALL CONFORM TO CALTRANS DESIGN STANDARDS AND POLICIES. RIGHT OF WAY MAY VARY PER THE REQUIREMENTS OF CALTRANS POLICY.
5. SEE SHEET 2 OF 2 FOR INTERSECTION CONFIGURATION AND TRANSITION.

NOT TO SCALE

NOTE: THIS WAS NUMBERED STANDARD No. 85 PRIOR TO 2023

PREPARED UNDER THE SUPERVISION OF:

*Mark Lancaster* 11/30/22  
 DIRECTOR OF TRANSPORTATION DATE  
 MARK LANCASTER, P.E.

REVISION	DESCRIPTION	MARK	DATE	APPROVED



COUNTY OF RIVERSIDE  
**6-LANE EXPRESSWAY  
 110' IMPROVEMENT  
 (142' R/W)**  
 STANDARD No. 86 (1 OF 2)



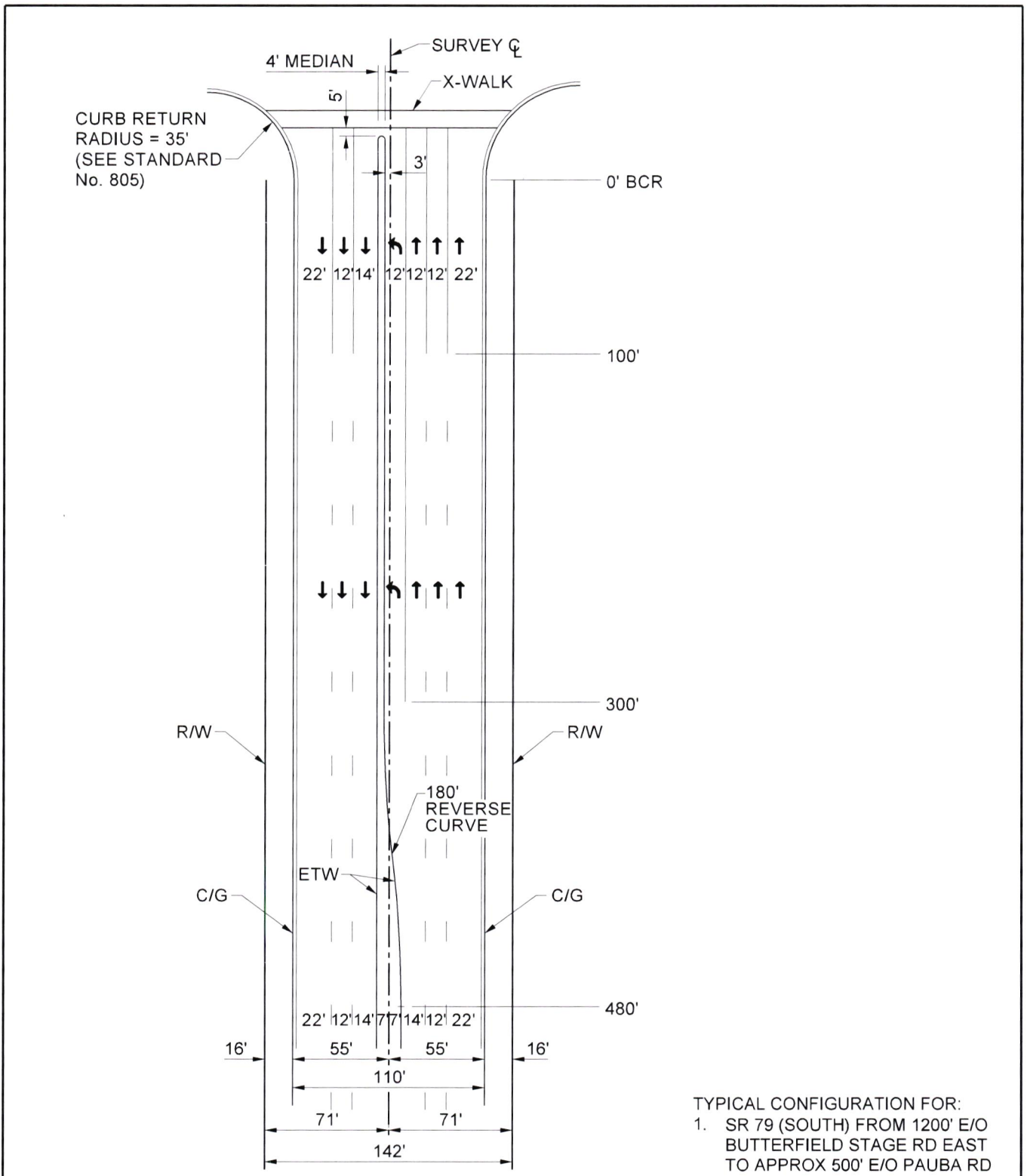

TYPICAL CONFIGURATION FOR:  
 1. SR 79 (SOUTH) FROM 1200' E/O BUTTERFIELD STAGE RD EAST TO APPROX 500' E/O PAUBA RD

NOT TO SCALE

NOTE: THIS WAS NUMBERED STANDARD No. 85 PRIOR TO 2023

PREPARED UNDER THE SUPERVISION OF:

*Mark Lancaster*

11/30/22

DIRECTOR OF TRANSPORTATION  
 MARK LANCASTER, P.E.

DATE



COUNTY OF RIVERSIDE

**6-LANE EXPRESSWAY  
 110' IMPROVEMENT  
 (142' R/W)**

**STANDARD No. 86 (2 OF 2)**

REVISION	DESCRIPTION	MARK	DATE	APPROVED

NOT TO SCALE	
PREPARED UNDER THE SUPERVISION OF:	
<i>Mark Lancaster</i>	
DIRECTOR OF TRANSPORTATION	
MARK LANCASTER, P.E.	
REVISION DESCRIPTION	DATE
MARK	APPROVED
DATE	11/30/22

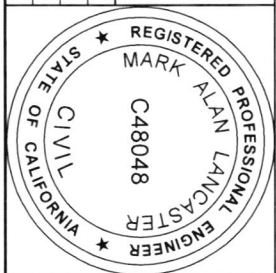

STANDARD No. 91 (1 OF 2)	URBAN ARTERIAL HIGHWAY (152' R/W)	COUNTY OF RIVERSIDE
--------------------------	-----------------------------------	---------------------

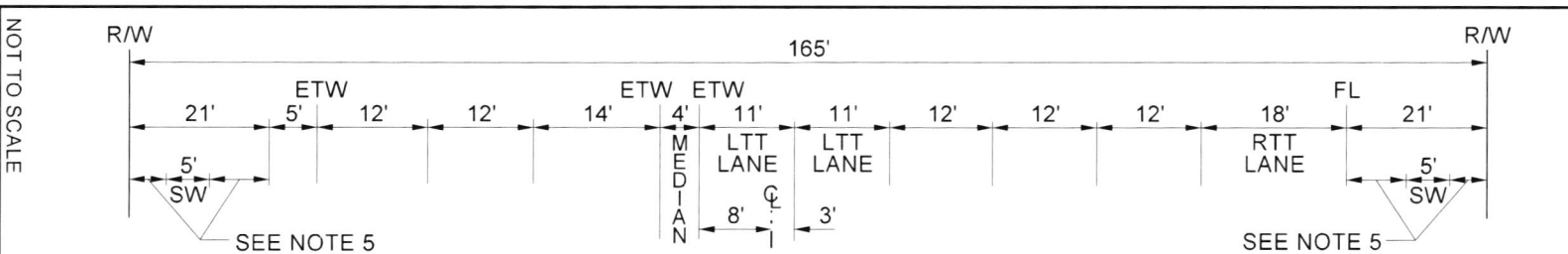

**CONFIGURATION AT INTERSECTION**  
(SEE SHEET 2 OF 2 FOR TRANSITIONS)

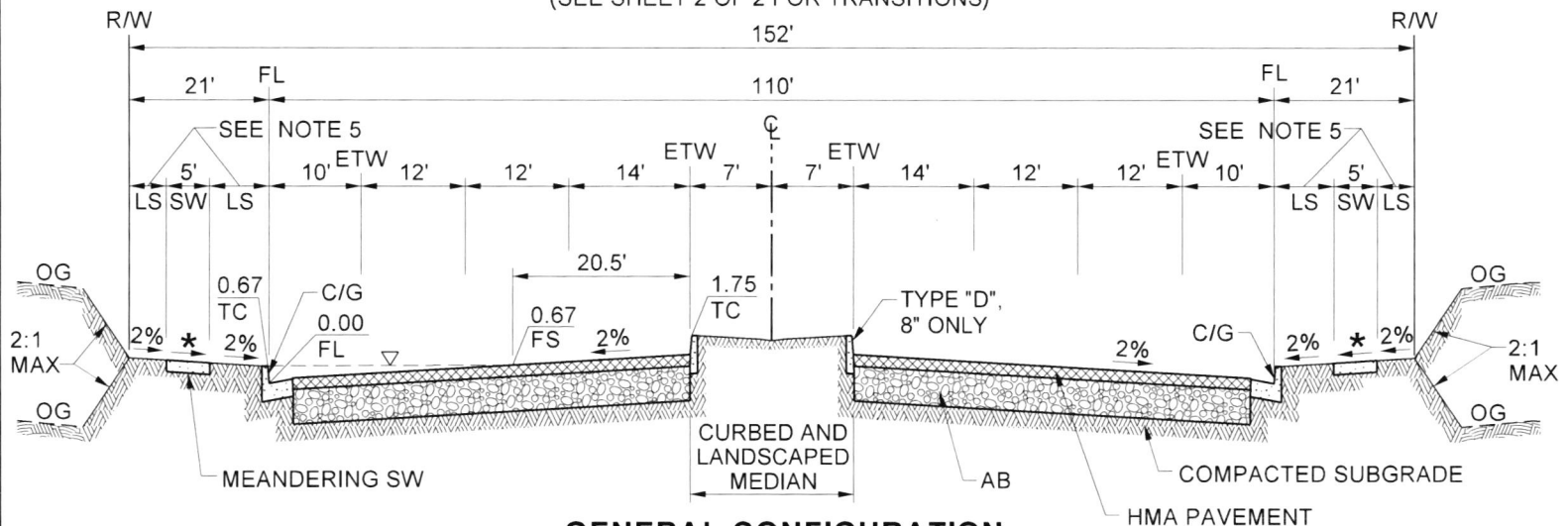

**GENERAL CONFIGURATION**

- NOTES:**
- THICKNESS OF AB AND HMA (FOR SHOULDER, AND FOR TRAVELED WAY) TO BE DETERMINED BY SOIL TEST AT TIME OF GRADING OPERATIONS.
  - MINIMUM PAVING THICKNESS PER SPECIFICATIONS SECTION 8.07 OF THIS ORDINANCE.
  - SEE STANDARD No. 113 FOR LANDSCAPED MEDIAN REQUIREMENTS, INCLUDING MEDIAN CURB.
  - CURB AND GUTTER TO BE TYPE "A-8" (STANDARD No. 201). 6" CURB IS NOT ALLOWED.
  - DISTANCE FROM SIDEWALK TO R/W, AND FLOW LINE, VARIES. SEE STANDARD No. 404 FOR DETAILS OF MEANDERING SIDEWALK.
  - MAX WATER DEPTH FOR  $Q_{10}$  IS 0.67' TO PROVIDE MIN 12' DRY LANE.
  - ADDITIONAL IMPROVEMENTS AND RIGHT OF WAY WIDTHS CONSISTING OF A 7' HALF-MEDIAN, 12' PAVED LANE, AN 8' GRADED SHOULDER AND 3' BEYOND THE SHOULDER MAY BE REQUIRED FOR PART WIDTH IMPROVEMENTS WHEN, AS DETERMINED BY THE TRANSPORTATION DEPARTMENT, AN ADDITIONAL LANE ON THE OPPOSITE SIDE OF THE CENTERLINE IS NEEDED.
  - ADDITIONAL IMPROVEMENTS AND RIGHT OF WAY WIDTH CONSISTING OF A 12' PAVED LANE MAY BE REQUIRED FOR THE RIGHT-TURN LANE WHEN THE PROJECT PROPOSES DIRECT ACCESS FROM THE GENERAL PLAN HIGHWAY, AS DETERMINED BY THE TRANSPORTATION DEPARTMENT.
- \* CROSS SLOPE OF SIDEWALK SHALL BE 1.5% (2.00% MAX AS-BUILT)

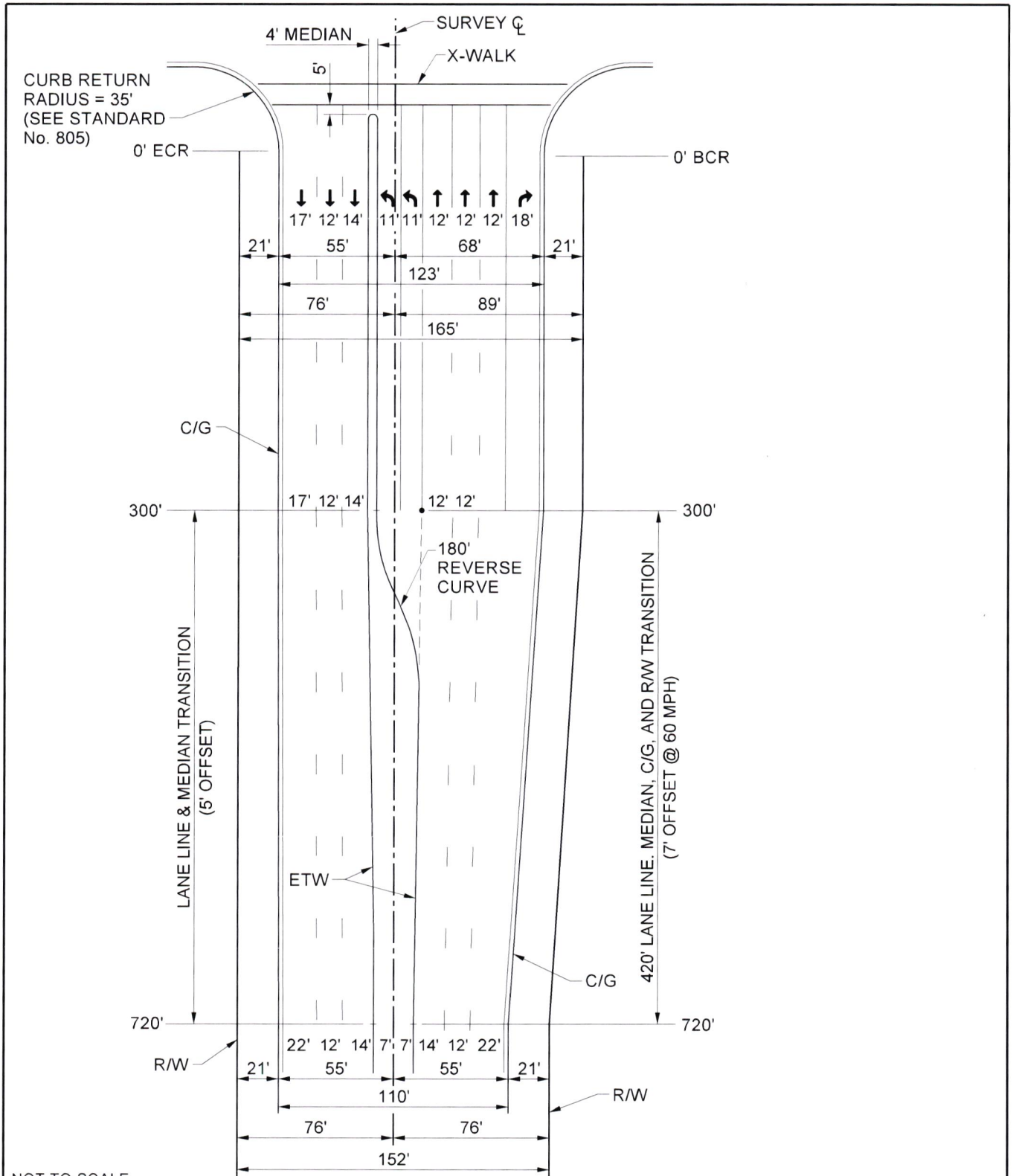

NOT TO SCALE

PREPARED UNDER THE SUPERVISION OF:

*Mark Lancaster* 11/30/22  
 DIRECTOR OF TRANSPORTATION DATE  
 MARK LANCASTER, P.E.



COUNTY OF RIVERSIDE

**URBAN ARTERIAL  
 HIGHWAY  
 (152' R/W)**

STANDARD No. 91 (2 OF 2)

REVISION DESCRIPTION	MARK	DATE	APPROVED

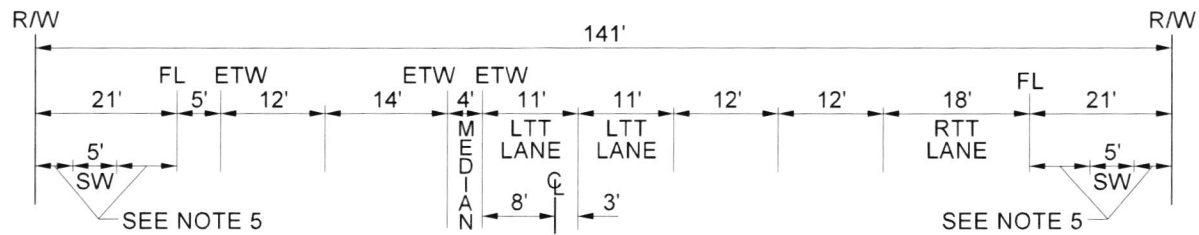

**CONFIGURATION AT INTERSECTION**  
(SEE SHEET 2 OF 2 FOR TRANSITIONS)

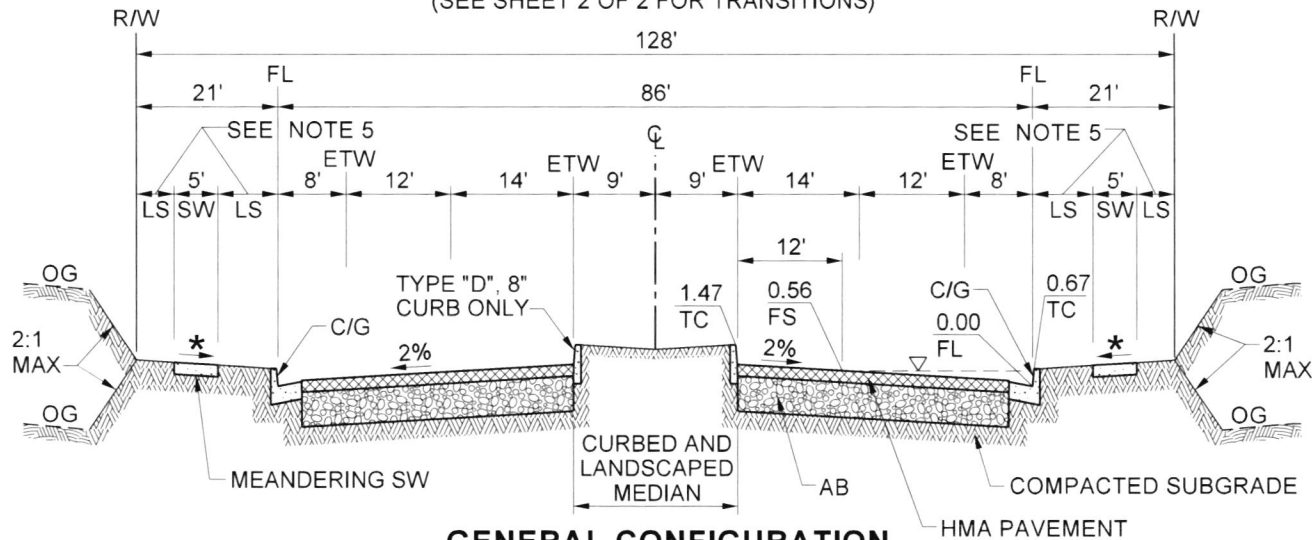

**GENERAL CONFIGURATION**

**NOTES:**

1. THICKNESS OF AB AND HMA (FOR SHOULDER, AND FOR TRAVELED WAY) TO BE DETERMINED BY SOIL TEST AT TIME OF GRADING OPERATIONS.
2. MINIMUM PAVING THICKNESS PER SPECIFICATIONS SECTION 8.07 OF THIS ORDINANCE.
3. SEE STANDARD No. 113 FOR LANDSCAPED MEDIAN REQUIREMENTS, INCLUDING MEDIAN CURB.
4. CURB AND GUTTER TO BE TYPE "A-8" (STANDARD No. 201). 6" CURB IS NOT ALLOWED.
5. DISTANCE FROM SIDEWALK TO R/W, AND FLOW LINE, VARIES. SEE STANDARD No. 404 FOR DETAILS OF MEANDERING SIDEWALK.
6. MAX WATER DEPTH FOR  $Q_{10}$  IS 0.56' TO PROVIDE MIN 12' DRY LANE.
7. ADDITIONAL IMPROVEMENTS AND RIGHT OF WAY WIDTHS CONSISTING OF A 9' HALF-MEDIAN, 12' PAVED LANE, AN 8' GRADED SHOULDER AND 3' BEYOND THE SHOULDER MAY BE REQUIRED FOR PART WIDTH IMPROVEMENTS WHEN, AS DETERMINED BY THE TRANSPORTATION DEPARTMENT, AN ADDITIONAL LANE ON THE OPPOSITE SIDE OF THE CENTERLINE IS NEEDED.
8. ADDITIONAL IMPROVEMENTS AND RIGHT OF WAY WIDTH CONSISTING OF A 12' PAVED LANE MAY BE REQUIRED FOR THE RIGHT-TURN LANE WHEN THE PROJECT PROPOSES DIRECT ACCESS FROM THE GENERAL PLAN HIGHWAY, AS DETERMINED BY THE TRANSPORTATION DEPARTMENT.

\* CROSS SLOPE OF SIDEWALK SHALL BE 1.5% (2.00% MAX AS-BUILT)

NOT TO SCALE

PREPARED UNDER THE SUPERVISION OF:

*Mark Lancaster*  
MARK LANCASTER, P.E.

DIRECTOR OF TRANSPORTATION

11/30/22  
DATE

REVISION DESCRIPTION

MARK DATE APPROVED



COUNTY OF RIVERSIDE

**ARTERIAL HIGHWAY**  
**(128' R/W)**

STANDARD No. 92 (1 OF 2)

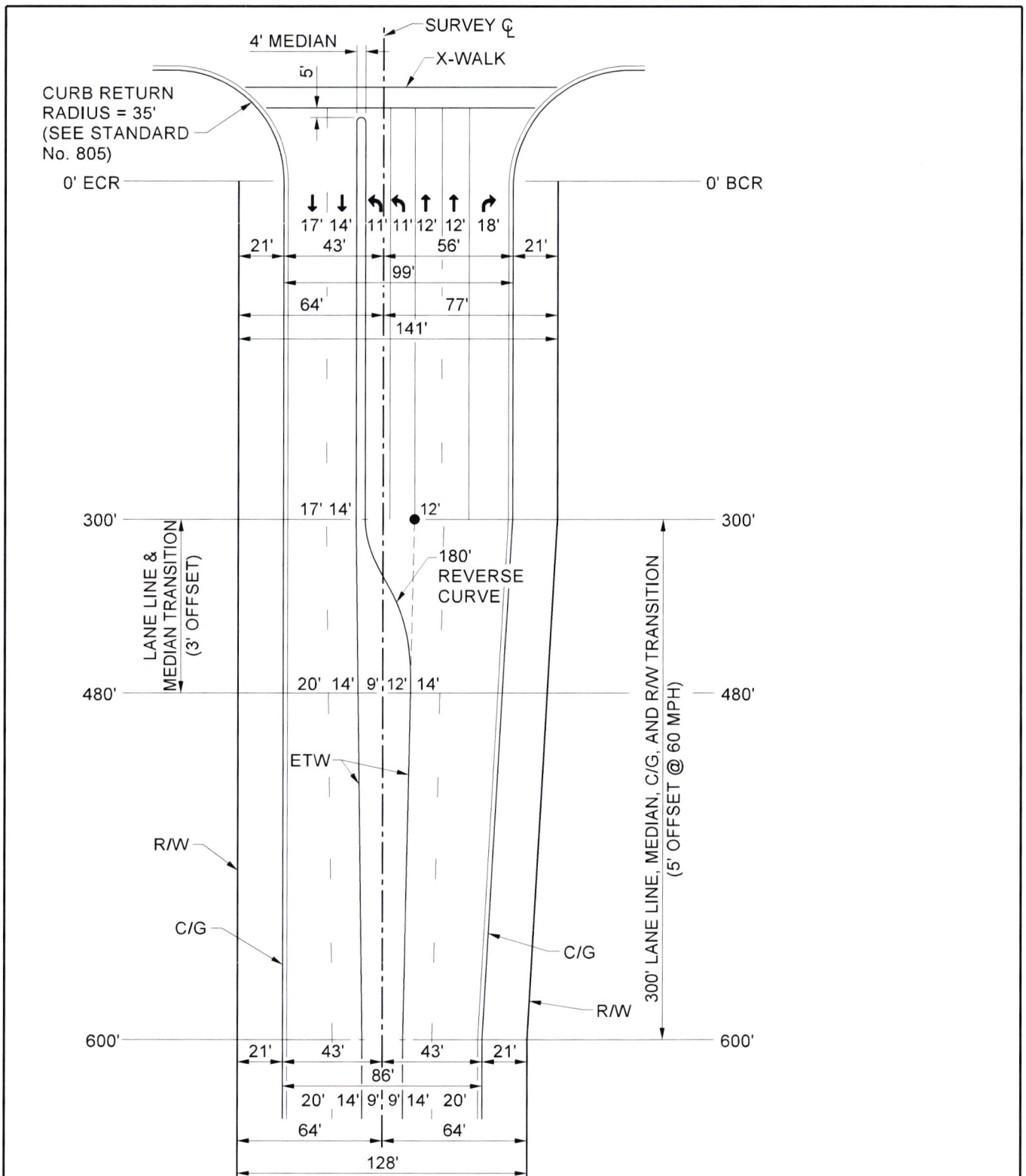

NOT TO SCALE

PREPARED UNDER THE SUPERVISION OF:

*Mark Lancaster*

11/30/22

DIRECTOR OF TRANSPORTATION  
MARK LANCASTER, P.E.

DATE



COUNTY OF RIVERSIDE

**ARTERIAL HIGHWAY  
(128' R/W)**

**STANDARD No. 92 (2 OF 2)**

REVISION	DESCRIPTION	MARK	DATE	APPROVED

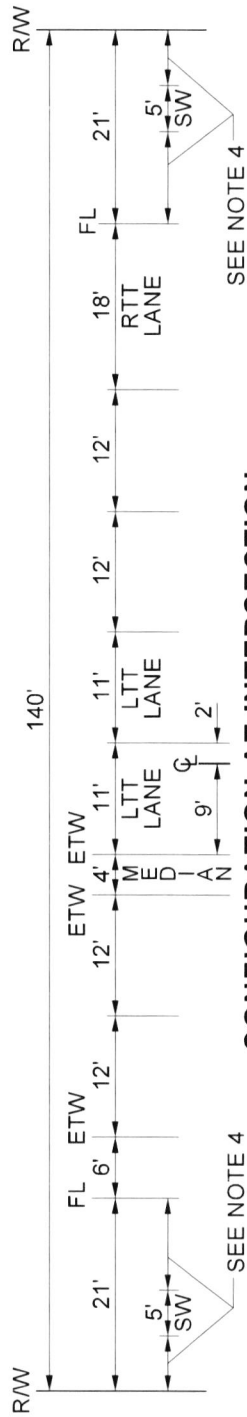

**CONFIGURATION AT INTERSECTION**  
(SEE SHEET 2 OF 2 FOR TRANSITIONS)

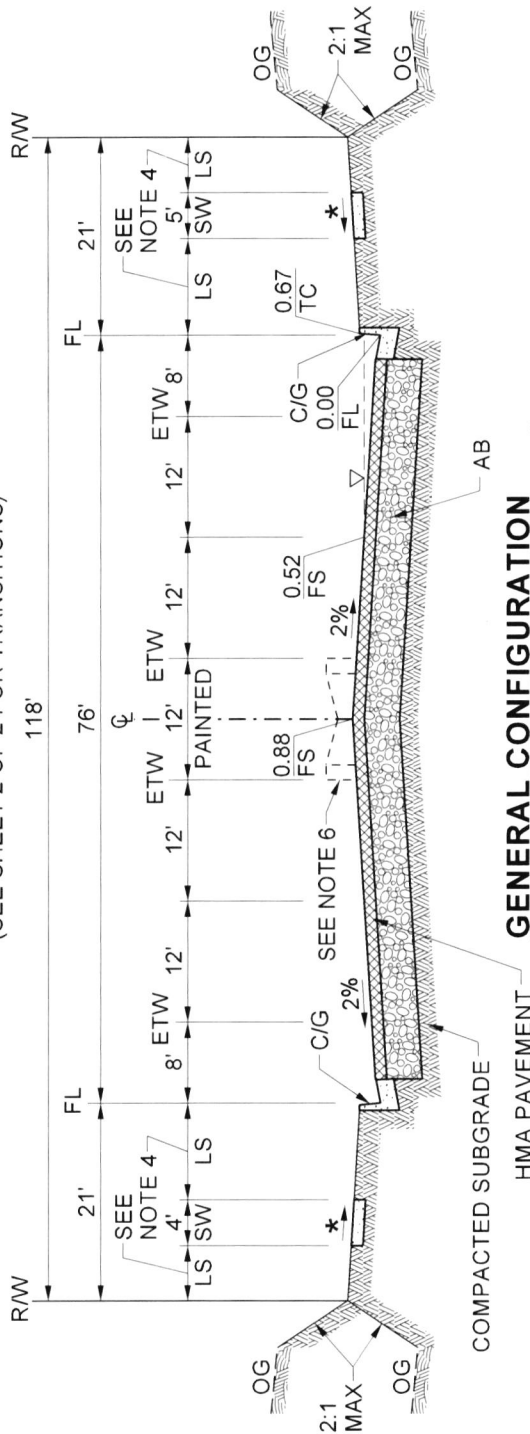

**NOTES:**

1. THICKNESS OF AB AND HMA (FOR SHOULDER, AND FOR TRAVELED WAY) TO BE DETERMINED BY SOIL TEST AT TIME OF GRADING OPERATIONS.
2. MINIMUM PAVING THICKNESS PER SPECIFICATIONS SECTION 8.07 OF THIS ORDINANCE.
3. CURB AND GUTTER TO BE TYPE "A-8" (STANDARD No. 201). 6" CURB IS NOT ALLOWED.
4. DISTANCE FROM SIDEWALK TO R/W, AND FLOW LINE, VARIES. SEE STANDARD No. 404 FOR DETAILS OF MEANDERING SIDEWALK.
5. MAX WATER DEPTH FOR Q<sub>10</sub> IS 0.52' TO PROVIDE MIN 12' DRY LANE.
6. A CURBED AND LANDSCAPED MEDIAN MAY BE REQUIRED.
7. ADDITIONAL IMPROVEMENTS AND RIGHT OF WAY WIDTHS CONSISTING OF A 6' HALF-WIDTH MEDIAN, 12' PAVED LANE, AN 8' GRADED SHOULDER AND 3' BEYOND THE SHOULDER MAY BE REQUIRED FOR PART WIDTH IMPROVEMENTS WHEN, AS DETERMINED BY THE TRANSPORTATION DEPARTMENT, AN ADDITIONAL LANE ON THE OPPOSITE SIDE OF THE CENTERLINE IS NEEDED.
8. ADDITIONAL IMPROVEMENTS AND RIGHT OF WAY WIDTH CONSISTING OF A 12' PAVED LANE MAY BE REQUIRED FOR THE RIGHT-TURN LANE WHEN THE PROJECT PROPOSES DIRECT ACCESS FROM THE GENERAL PLAN HIGHWAY, AS DETERMINED BY THE TRANSPORTATION DEPARTMENT.

**GENERAL CONFIGURATION**

\* CROSS SLOPE OF SIDEWALK SHALL BE 1.5% (2.00% MAX AS-BUILT)

NOT TO SCALE

PREPARED UNDER THE SUPERVISION OF:

*Mark Lancaster* 11/30/22  
DIRECTOR OF TRANSPORTATION DATE  
MARK LANCASTER, P.E.

REVISION	DESCRIPTION	MARK	DATE	APPROVED



COUNTY OF RIVERSIDE

**MAJOR HIGHWAY  
(118' R/W)**

STANDARD No. 93 (1 OF 2)

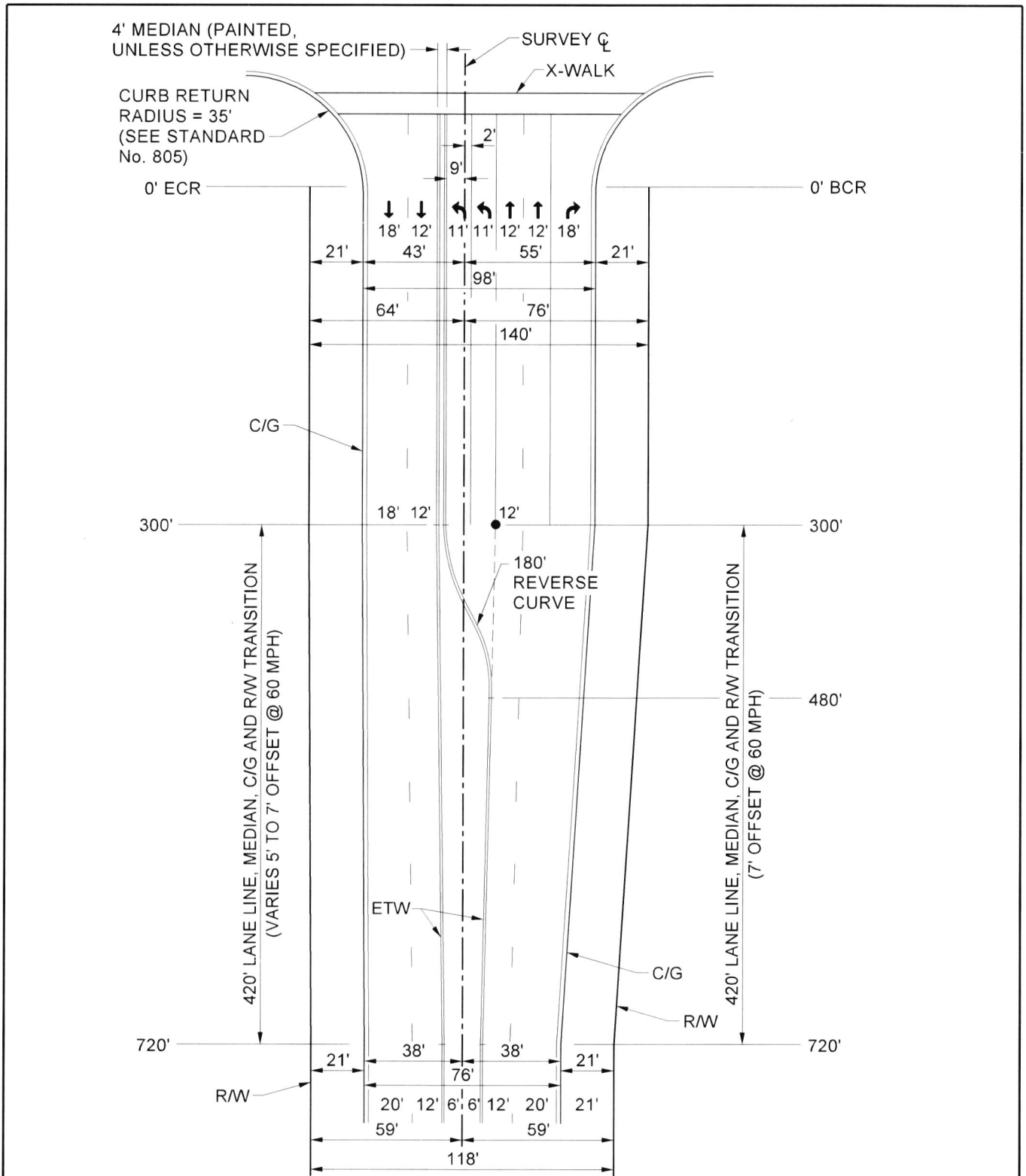

NOT TO SCALE

PREPARED UNDER THE SUPERVISION OF:

*Mark Lancaster*

DIRECTOR OF TRANSPORTATION  
MARK LANCASTER, P.E.

11/30/22  
DATE



COUNTY OF RIVERSIDE

**MAJOR HIGHWAY  
(118' R/W)**

**STANDARD No. 93 (2 OF 2)**

REVISION	DESCRIPTION	MARK	DATE	APPROVED

NOT TO SCALE  
 PREPARED UNDER THE SUPERVISION OF:  
*Mark Lancaster*  
 DIRECTOR OF TRANSPORTATION  
 MARK LANCASTER, P.E.  
 11/30/22  
 DATE  
 REVISION DESCRIPTION  
 MARK DATE APPROVED



COUNTY OF RIVERSIDE  
**SECONDARY HIGHWAY**  
**(100' R/W)**  
 STANDARD No. 94 (1 OF 2)

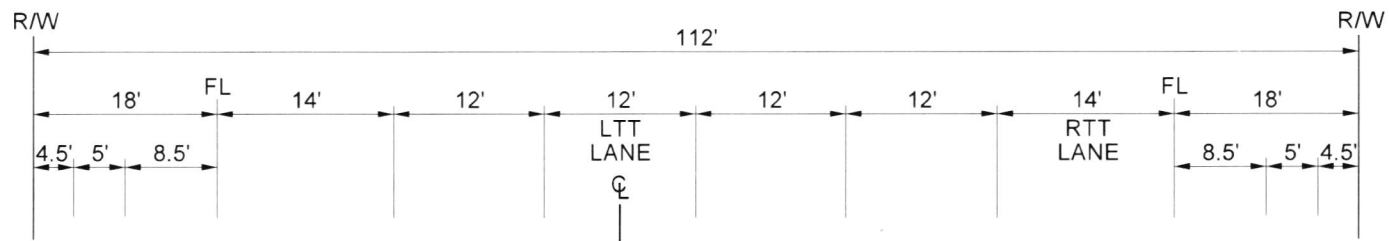

**CONFIGURATION AT INTERSECTION**

(SEE SHEET 2 OF 2 FOR TRANSITIONS)

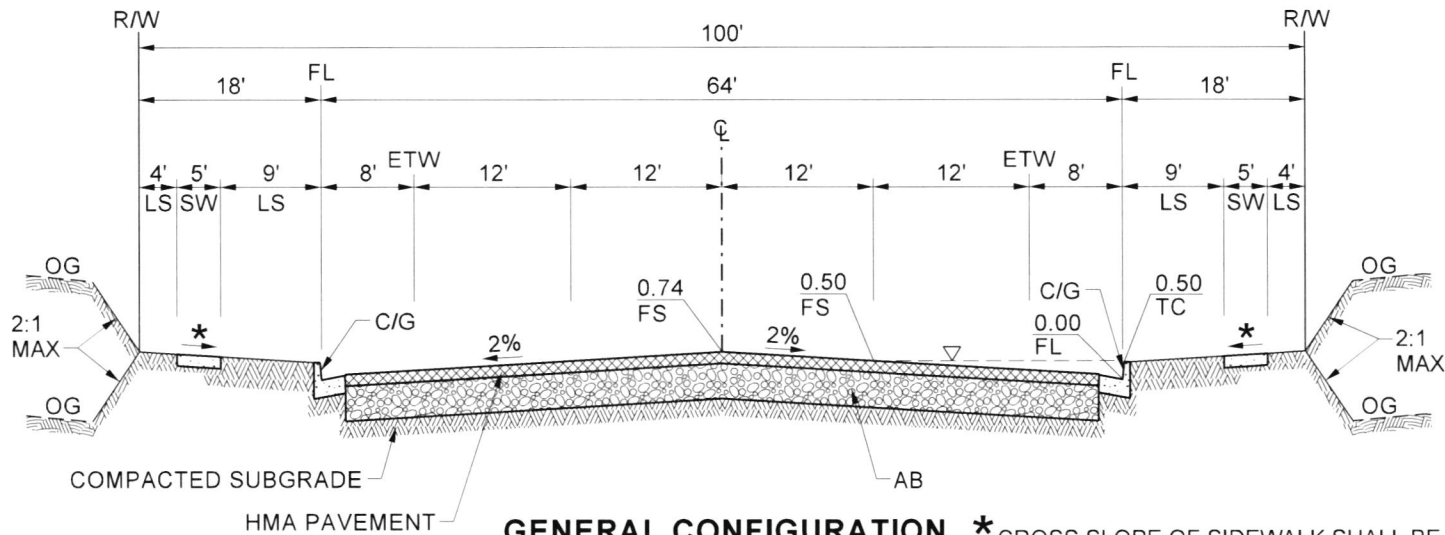

**GENERAL CONFIGURATION**

\* CROSS SLOPE OF SIDEWALK SHALL BE 1.5% (2.00% MAX AS-BUILT)

**NOTES:**

1. THICKNESS OF AB AND HMA (FOR SHOULDER, AND FOR TRAVELED WAY) TO BE DETERMINED BY SOIL TEST AT TIME OF GRADING OPERATIONS.
2. MINIMUM PAVING THICKNESS PER SPECIFICATIONS SECTION 8.07 OF THIS ORDINANCE.
3. CURB AND GUTTER TO BE TYPE "A-6" (STANDARD No. 200). 8" CURB IS NOT ALLOWED.
4. MAX WATER DEPTH FOR Q<sub>10</sub> IS 0.50' TO PROVIDE MIN 12' DRY LANE.
5. ADDITIONAL IMPROVEMENTS AND RIGHT OF WAY WIDTHS CONSISTING OF A 12' PAVED LANE, AN 8' GRADED SHOULDER AND 3' BEYOND THE SHOULDER MAY BE REQUIRED FOR PART WIDTH IMPROVEMENTS WHEN, AS DETERMINED BY THE TRANSPORTATION DEPARTMENT, AN ADDITIONAL LANE ON THE OPPOSITE SIDE OF THE CENTERLINE IS NEEDED.
6. ADDITIONAL IMPROVEMENTS AND RIGHT OF WAY WIDTH CONSISTING OF A 12' PAVED LANE MAY BE REQUIRED FOR THE RIGHT-TURN LANE WHEN THE PROJECT PROPOSES DIRECT ACCESS FROM THE GENERAL PLAN HIGHWAY, AS DETERMINED BY THE TRANSPORTATION DEPARTMENT.



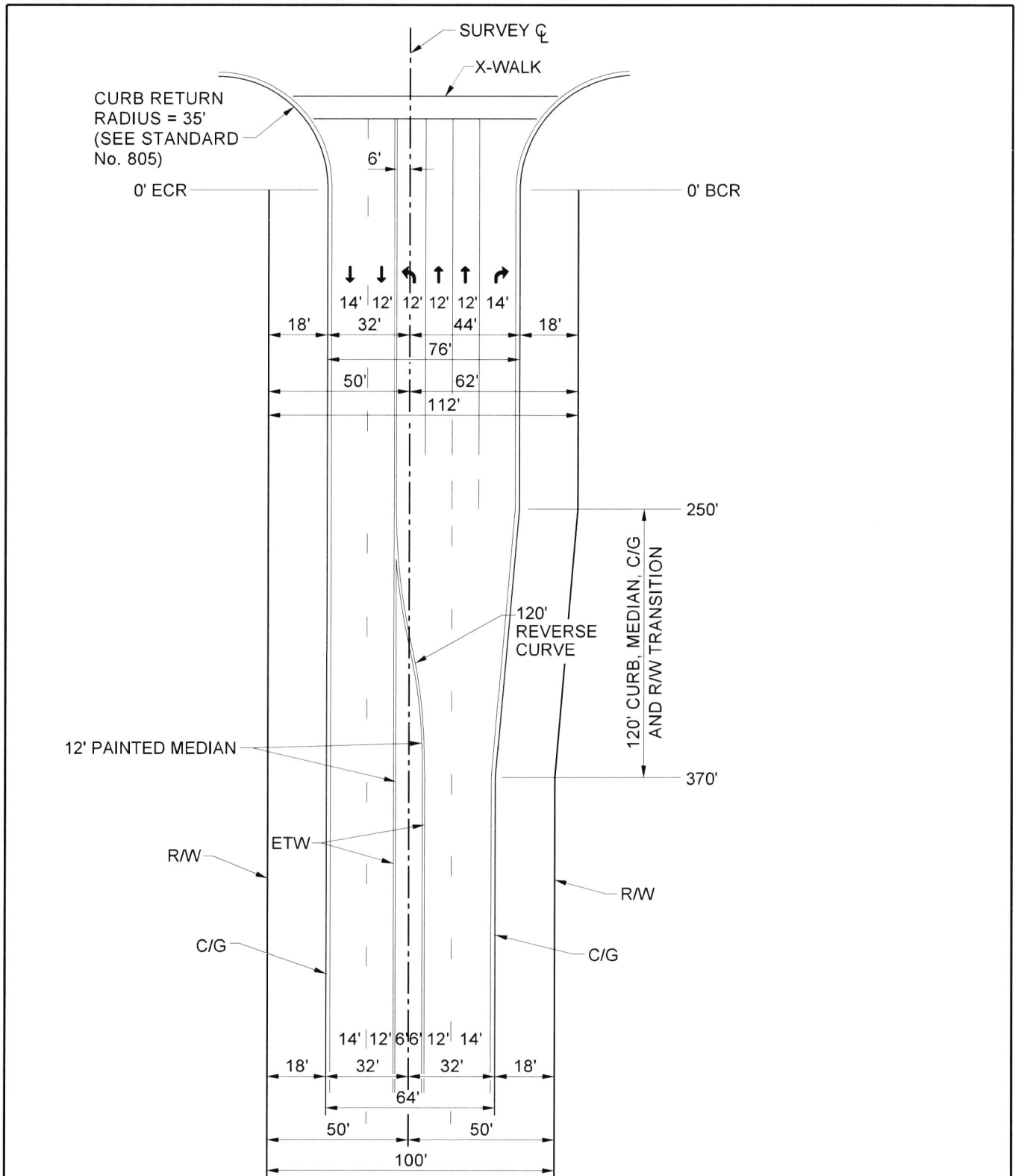

NOT TO SCALE

PREPARED UNDER THE SUPERVISION OF:

*Mark Lancaster*

DIRECTOR OF TRANSPORTATION  
MARK LANCASTER, P.E.

11/30/22  
DATE



COUNTY OF RIVERSIDE

**SECONDARY HIGHWAY  
(100' R/W)**

**STANDARD No. 94 (2 OF 2)**

REVISION DESCRIPTION	MARK	DATE	APPROVED

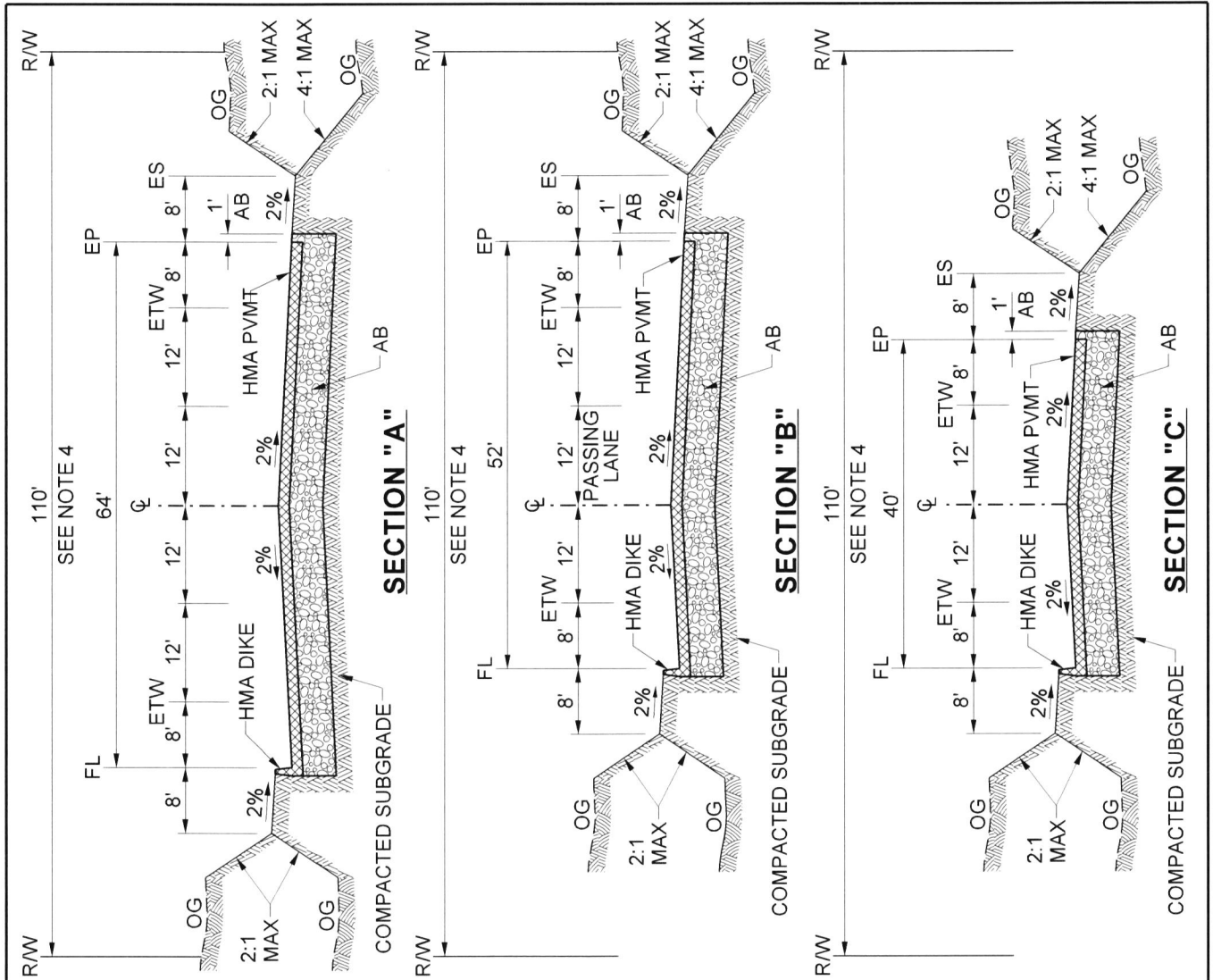

**NOTES:**

1. THICKNESS OF AB AND HMA TO BE DETERMINED BY SOIL TEST AT TIME OF GRADING OPERATIONS.
2. MINIMUM PAVING THICKNESS PER SPECIFICATIONS SECTION 8.07 OF THIS ORDINANCE.
3. SEE STANDARD No. 212 FOR HMA DIKE DETAIL AND REQUIREMENTS. HMA DIKE MAY BE REQUIRED ON ONE OR BOTH SIDES.
4. CONCRETE CURB, GUTTER, AND SIDEWALK MAY BE REQUIRED AS DETERMINED BY THE DIRECTOR OF TRANSPORTATION.

NOT TO SCALE

PREPARED UNDER THE SUPERVISION OF:

*Mark Lancaster*  
 DIRECTOR OF TRANSPORTATION  
 MARK LANCASTER, P.E.  
 11/30/22  
 DATE

REVISION	DESCRIPTION	MARK	DATE	APPROVED



COUNTY OF RIVERSIDE

**MOUNTAIN ARTERIAL  
 HIGHWAY  
 (110' R/W)**

**STANDARD No. 95**

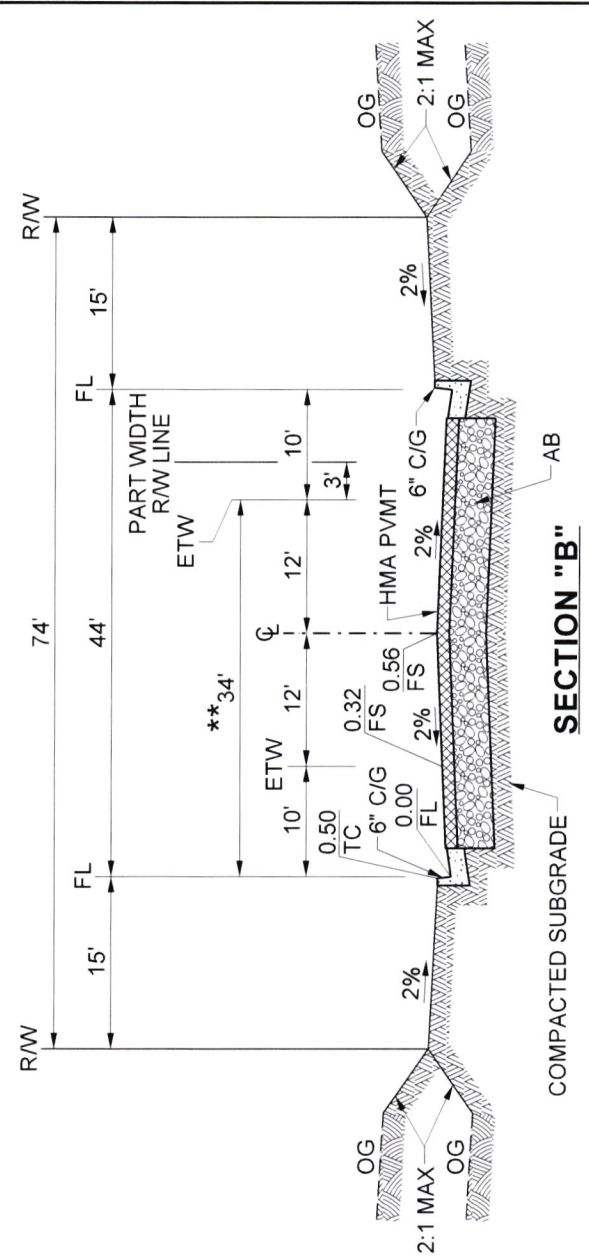
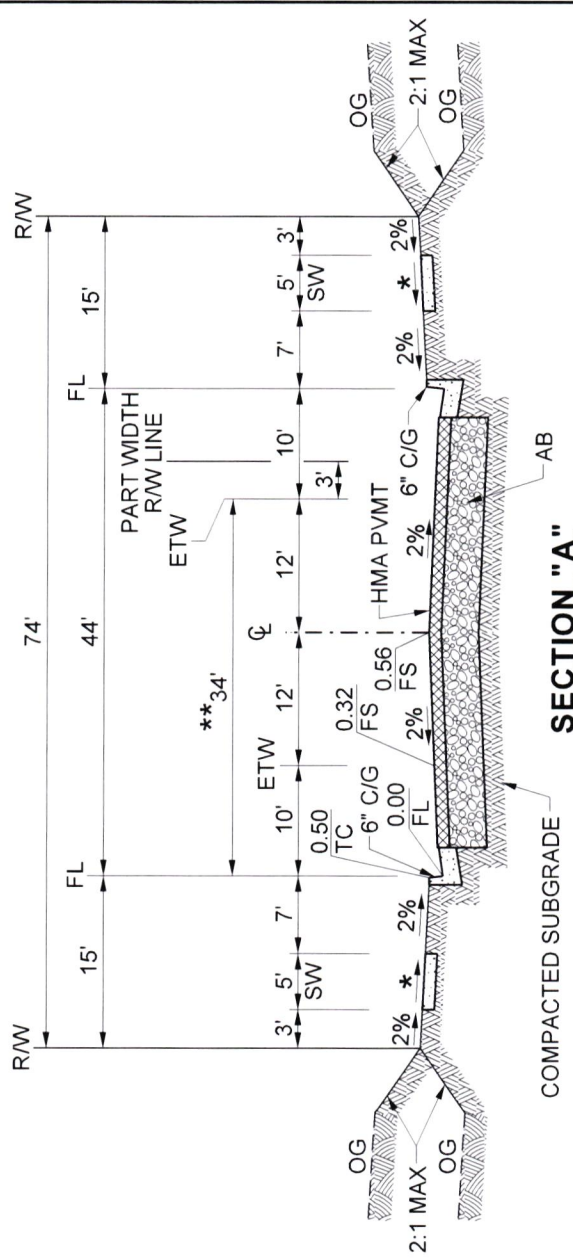

\* CROSS SLOPE OF SIDEWALK SHALL BE 1.5% (2.00% MAX AS-BUILT)  
 \*\* PART WIDTH STREET SECTION: 34' IMPROVEMENTS ON 52'

**NOTES:**

1. THICKNESS OF AB AND HMA TO BE DETERMINED BY SOIL TEST AT TIME OF GRADING OPERATIONS.
2. MINIMUM PAVING THICKNESS PER SPECIFICATIONS SECTION 8.07 OF THIS ORDINANCE.
3. CURB AND GUTTER TO BE TYPE "A-6" (STANDARD No. 200). 8" CURB IS NOT ALLOWED.
4. DIRECT RESIDENTIAL DRIVEWAY ACCESS PROHIBITED.

NOT TO SCALE

PREPARED UNDER THE SUPERVISION OF:

*Mark Lancaster*

11/30/22  
DATE

DIRECTOR OF TRANSPORTATION  
MARK LANCASTER, P.E.



COUNTY OF RIVERSIDE

**COLLECTOR STREET  
(NO ACCESS)  
(74' R/W)**

**STANDARD No. 103**

REVISION	DESCRIPTION	MARK	DATE	APPROVED

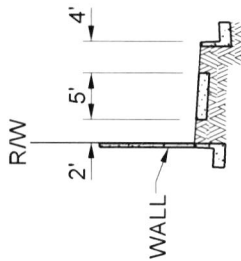

**SIDEWALK LOCATION**  
IF WALL IS PROPOSED

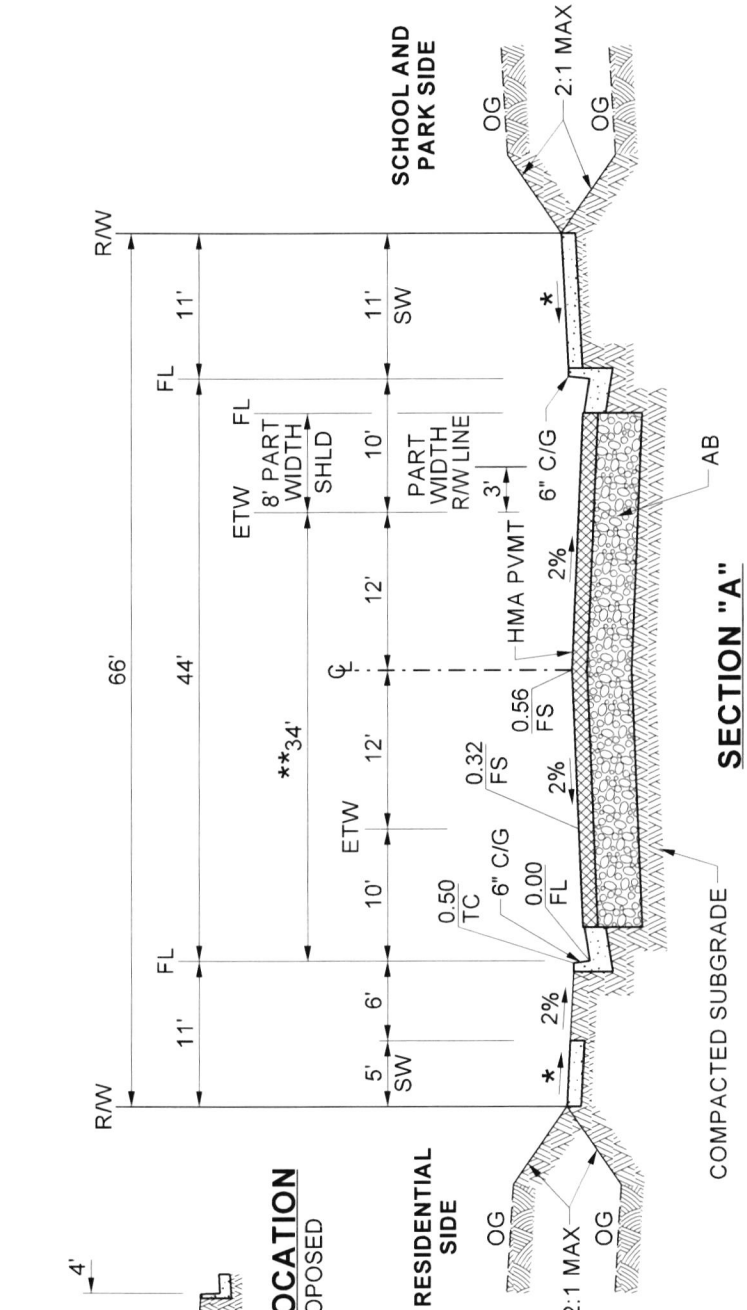

- \* CROSS SLOPE OF SIDEWALK SHALL BE 1.5% (2.00% MAX AS-BUILT)
- \*\* PART-WIDTH STREET SECTION: 34' IMPROVEMENTS ON 48' R/W

**NOTES:**

1. THICKNESS OF AB AND HMA TO BE DETERMINED BY SOIL TEST AT TIME OF GRADING OPERATIONS.
2. MINIMUM PAVING THICKNESS PER SPECIFICATIONS SECTION 8.07 OF THIS ORDINANCE.
3. CURB AND GUTTER TO BE TYPE "A-6" (STANDARD No. 200). 8" CURB IS NOT ALLOWED.
4. THIS STANDARD MAY ALSO TERMINATE AT A CUL-DE-SAC IN INDUSTRIAL OR COMMERCIAL USE AREAS BUT SHALL NOT EXCEED 660 FEET IN LENGTH OF ROADWAY/STREET.
5. WHEN ABUTTING SOIL HAS A HIGH SULFATE CONTENT, SPECIAL CONSIDERATIONS ARE REQUIRED. SEE SPECIFICATIONS SECTION 16.04 OF THIS ORDINANCE.

NOT TO SCALE

PREPARED UNDER THE SUPERVISION OF:

*Mark Lancaster* 11/30/22  
 DIRECTOR OF TRANSPORTATION DATE  
 MARK LANCASTER, P.E.

REVISION DESCRIPTION	MARK	DATE	APPROVED



COUNTY OF RIVERSIDE  
**ENHANCED LOCAL STREET ADJACENT TO SCHOOL OR PARK (66' R/W)**  
 STANDARD No. 104 (1 OF 2)

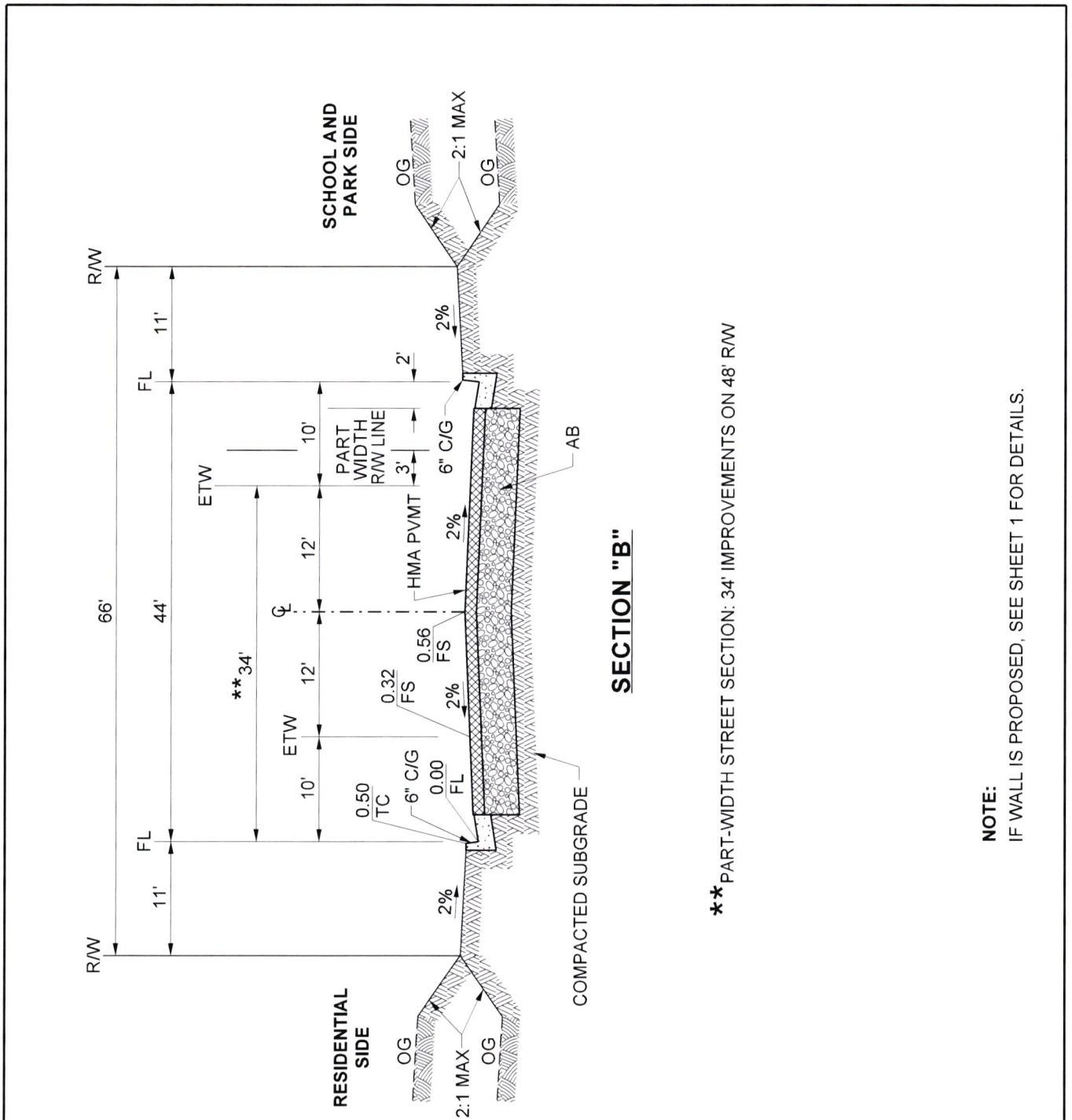

\*\* PART-WIDTH STREET SECTION: 34' IMPROVEMENTS ON 48' R/W

NOTE:  
IF WALL IS PROPOSED, SEE SHEET 1 FOR DETAILS.

NOT TO SCALE

PREPARED UNDER THE SUPERVISION OF:

*Mark Lancaster*

11/30/22  
DATE

DIRECTOR OF TRANSPORTATION  
MARK LANCASTER, P.E.



COUNTY OF RIVERSIDE

**ENHANCED LOCAL  
STREET ADJACENT TO  
SCHOOL OR PARK  
(66' R/W)**

STANDARD No. 104 (2 OF 2)

REVISION DESCRIPTION	MARK	DATE	APPROVED

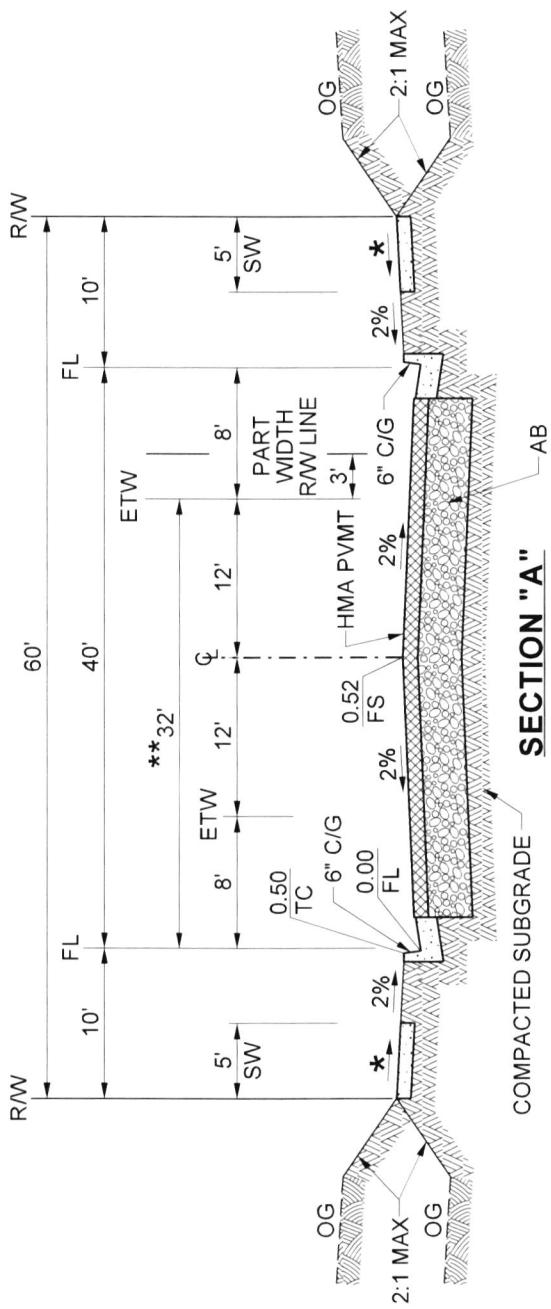

**SECTION "A"**

\* CROSS SLOPE OF SIDEWALK SHALL BE 1.5% (2.00% MAX AS-BUILT)  
 \*\* PART-WIDTH STREET SECTION: 32' IMPROVEMENTS ON 45' RW

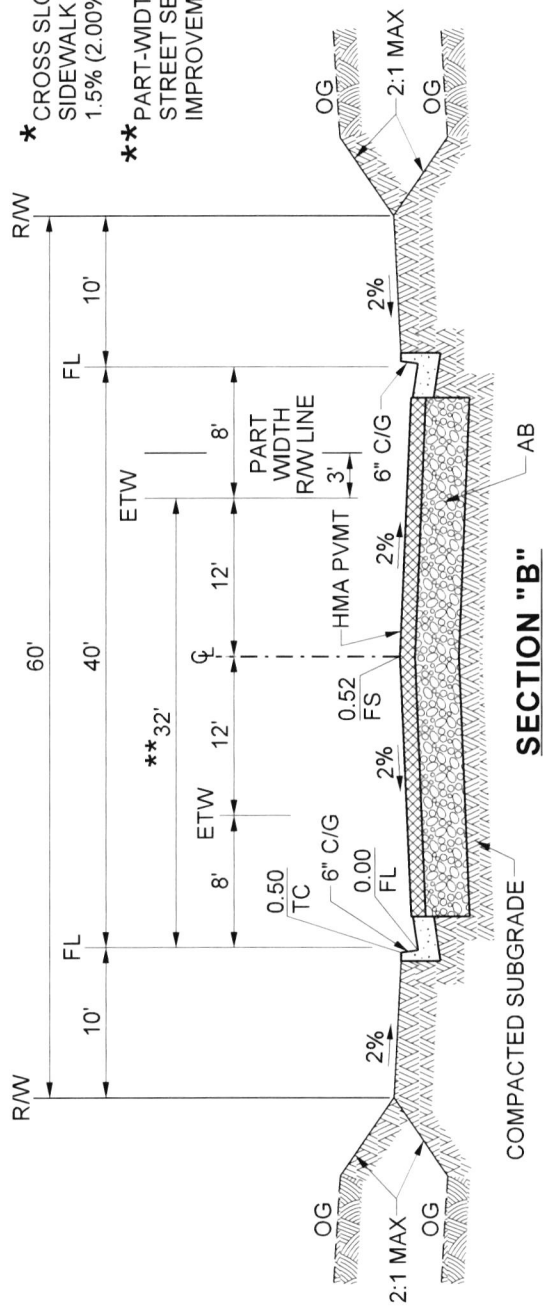

**SECTION "B"**

- NOTES:**
1. THICKNESS OF AB AND HMA TO BE DETERMINED BY SOIL TEST AT TIME OF GRADING OPERATIONS.
  2. MINIMUM PAVING THICKNESS PER SPECIFICATIONS SECTION 8.07 OF THIS ORDINANCE.
  3. CURB AND GUTTER TO BE TYPE "A-6" (STANDARD No. 200). 8" CURB IS NOT ALLOWED.
  4. ROADWAY CROSS-SECTION LESS THAN 40 FT IN WIDTH IS LIMITED TO PARKING ON ONE SIDE OF THE STREET.

NOT TO SCALE

PREPARED UNDER THE SUPERVISION OF:

*Mark Lancaster* 11/30/22  
 DIRECTOR OF TRANSPORTATION DATE  
 MARK LANCASTER, P.E.

REVISION	DESCRIPTION	MARK	DATE	APPROVED



COUNTY OF RIVERSIDE

**EXTERIOR & LOCAL STREET  
(60' R/W)**

**STANDARD No. 105A**

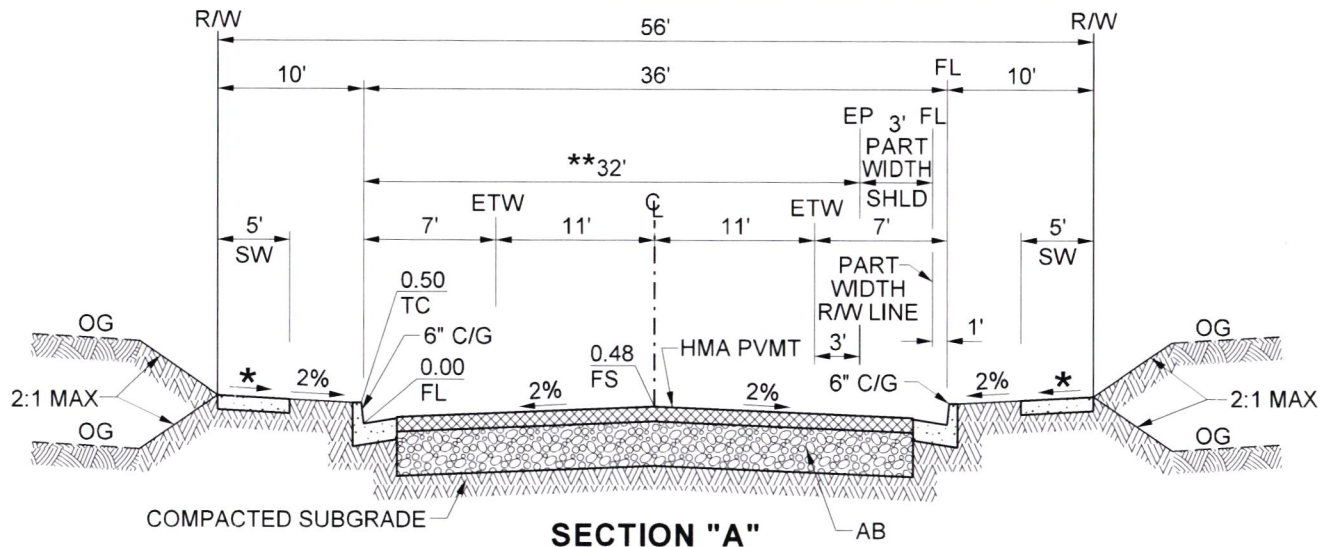

**SECTION "A"**

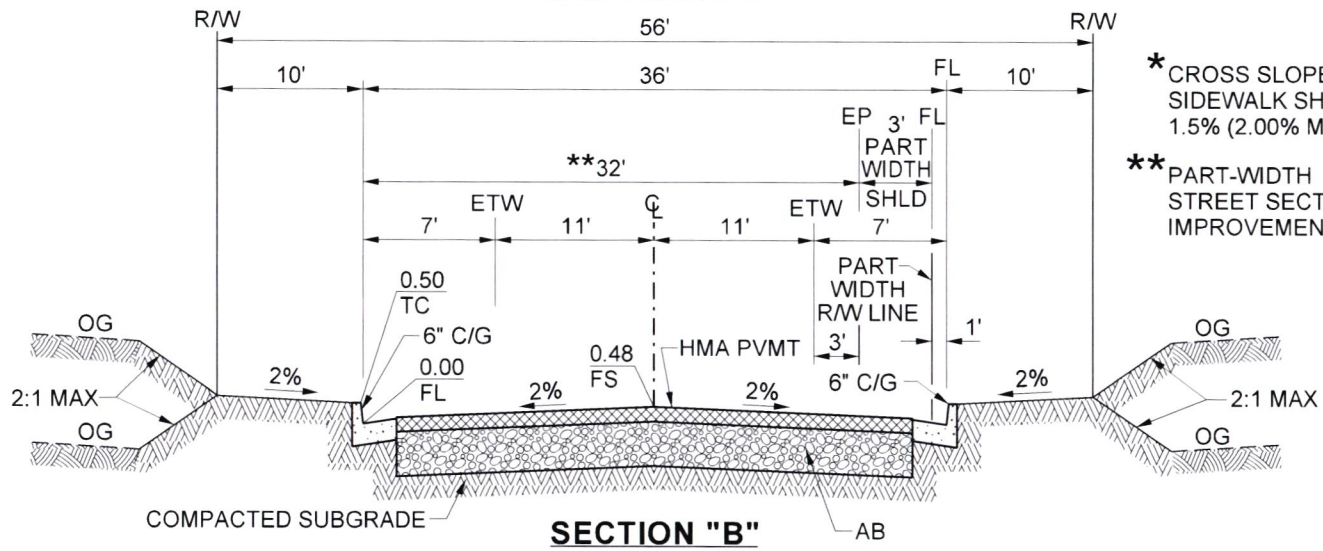

**SECTION "B"**

\* CROSS SLOPE OF SIDEWALK SHALL BE 1.5% (2.00% MAX AS-BUILT)  
 \*\* PART-WIDTH STREET SECTION: 32' IMPROVEMENTS ON 45' R/W

**NOTES:**

1. THICKNESS OF AB AND HMA TO BE DETERMINED BY SOIL TEST AT TIME OF GRADING OPERATIONS.
2. MINIMUM PAVING THICKNESS PER SPECIFICATIONS SECTION 8.07 OF THIS ORDINANCE.
3. CURB AND GUTTER TO BE TYPE "A-6" (STANDARD No. 200). 8" CURB IS NOT ALLOWED.
4. FOR UNDERGROUND UTILITY LOCATIONS SEE STANDARD No. 817.
5. ROADWAY CROSS-SECTION LESS THAN 40 FT IN WIDTH IS LIMITED TO PARKING ON ONE SIDE OF THE STREET.

NOT TO SCALE

PREPARED UNDER THE SUPERVISION OF:

*Mark Lancaster*

DIRECTOR OF TRANSPORTATION  
 MARK LANCASTER, P.E. 11/30/22

REVISION DESCRIPTION	MARK	DATE	APPROVED



COUNTY OF RIVERSIDE

**SHORT LOCAL STREET**  
**(56' R/W)**

STANDARD No. 105B

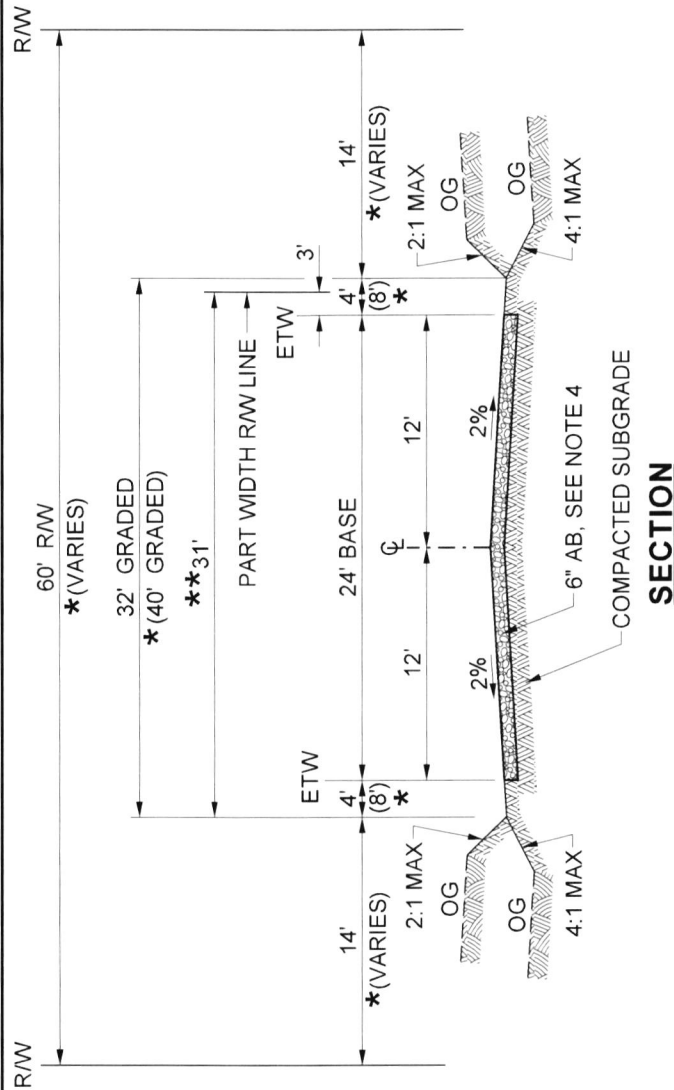

**SECTION**

- \* WHEN GENERAL PLAN HIGHWAY
- \*\* PART-WIDTH STREET SECTION: 24' AB / 31' GRADED / 45' R/W

**NOTES:**

1. THICKNESS OF AB TO BE DETERMINED BY SOIL TEST AT TIME OF GRADING OPERATIONS.
2. AB PER SPECIFICATIONS SECTION 10 OF THIS ORDINANCE.
3. SOIL STABILIZER TO BE APPLIED PER IMPROVEMENTS PLANS. THE GRADED ROAD SHALL BE TREATED WITH A DUST SUPPRESSANT THAT IS DESIGNED TO PROVIDE LONG LASTING CONTROL OF FUGITIVE DUST ON A DRIVEABLE SURFACE. SAID TREATMENT SHALL BE SUBMITTED DURING IMPROVEMENT PLAN CHECK AND APPROVED BY THE TRANSPORTATION DEPARTMENT. CHEMICAL DUST SUPPRESSANTS SHALL MEET ALL REQUIREMENTS OF STATE AND FEDERAL SAFETY AND ENVIRONMENTAL REGULATIONS.
4. AGGREGATE BASE TO BE OF CLASS 3 OR CLASS 4. THE USE OF EXISTING NATIVE MATERIAL MAY BE ALLOWED IF MEETS CLASS 3 OR 4 AGGREGATE BASE PER SPECIFICATION SECTION 10 OF THIS ORDINANCE.
5. GRADE ROADWAY AND SHOULDER AT 2.00%.
6. RELATIVE COMPACTION OF SUBGRADE AND BASE MATERIAL SHALL BE 95% MIN.

NOT TO SCALE

PREPARED UNDER THE SUPERVISION OF:

*Mark Lancaster*  
 DIRECTOR OF TRANSPORTATION  
 MARK LANCASTER, P.E.  
 DATE 11/30/22

REVISION	DESCRIPTION	MARK	DATE	APPROVED



COUNTY OF RIVERSIDE  
**UNPAVED LOCAL ROAD/  
 UNPAVED ACCESS ROAD  
 (60' R/W)**  
 STANDARD No. 105C



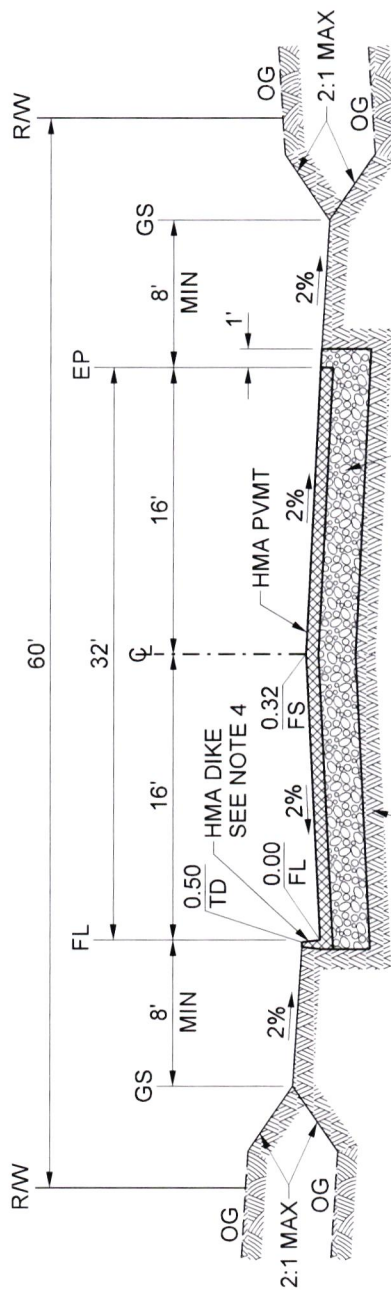

**SECTION "A"**

32' PAVED / 48' GRADED / 60' R/W

COMPACTED SUBGRADE

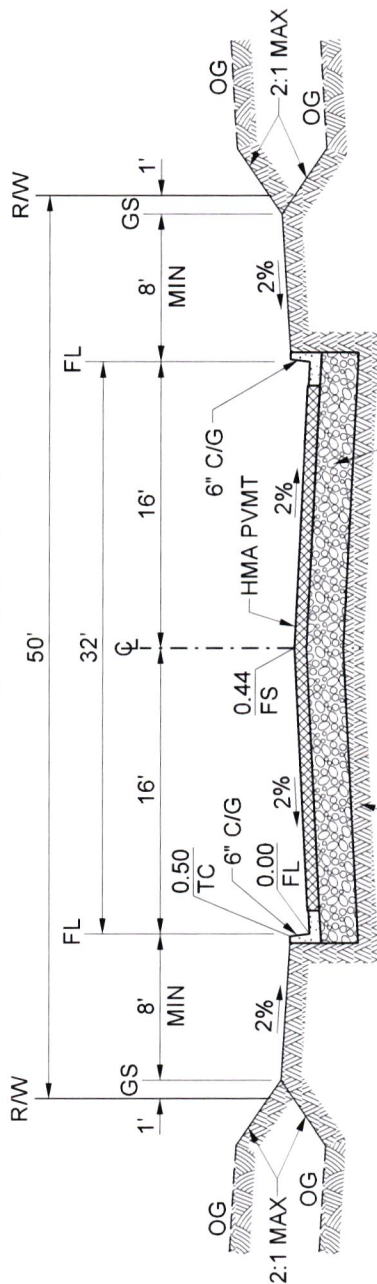

**SECTION "B"**

32' PAVED / 48' GRADED / 50' R/W

COMPACTED SUBGRADE

**NOTES:**

1. THICKNESS OF AB AND HMA TO BE DETERMINED BY SOIL TEST AT TIME OF GRADING OPERATIONS.
2. MINIMUM PAVING THICKNESS PER SPECIFICATIONS SECTION 8.07 OF THIS ORDINANCE. FOR ACCESS ROADS, IF THE ULTIMATE ROAD CLASSIFICATION IS A GENERAL PLAN HIGHWAY, THE TRAFFIC INDEX REQUIREMENT IS 7.0.
3. SEE STANDARD No. 212 FOR HMA DIKE DETAIL AND REQUIREMENTS.
4. FOR ACCESS ROAD 6" HMA DIKE MAY BE REQUIRED ON ONE OR BOTH SIDES.
5. CURB AND GUTTER TO BE TYPE "A-6" (STANDARD No. 200). 8" CURB IS NOT ALLOWED.
6. ROADWAY CROSS-SECTION LESS THAN 40 FT IN WIDTH IS LIMITED TO PARKING ON ONE SIDE OF THE STREET.

NOT TO SCALE

PREPARED UNDER THE SUPERVISION OF:

*Mark Lancaster*

11/30/22

DIRECTOR OF TRANSPORTATION  
MARK LANCASTER, P.E.

DATE



COUNTY OF RIVERSIDE

**ACCESS ROAD,  
CONSTRAINED LOCAL  
STREET OR PRIVATE STREET  
(50'-60' R/W)**

**STANDARD No. 106**

REVISION DESCRIPTION	MARK	DATE	APPROVED

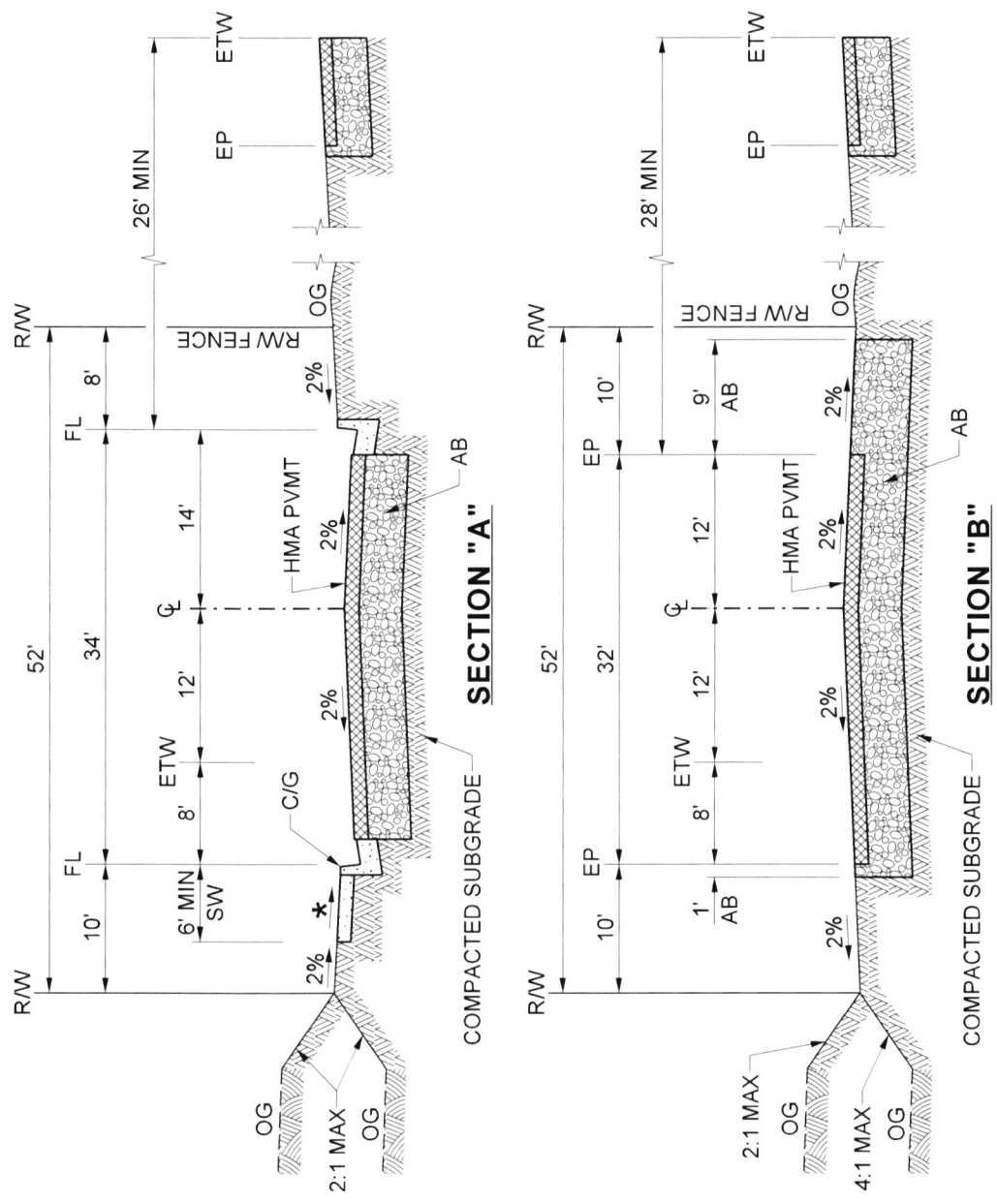

\* CROSS SLOPE OF SIDEWALK SHALL BE 1.5% (2.00% MAX AS-BUILT)

**NOTES:**

1. THICKNESS OF AB AND HMA TO BE DETERMINED BY SOIL TEST AT TIME OF GRADING OPERATIONS.
2. MINIMUM PAVING THICKNESS PER SPECIFICATIONS SECTION 8.07 OF THIS ORDINANCE.
3. CURB AND GUTTER TO BE TYPE "A-6" (STANDARD No. 200). 8" CURB IS NOT ALLOWED.
4. ROADWAY CROSS-SECTION LESS THAN 40 FT IN WIDTH IS LIMITED TO PARKING ON ONE SIDE OF THE STREET.

NOT TO SCALE

PREPARED UNDER THE SUPERVISION OF:

*Mark Lancaster* 11/30/22  
 DIRECTOR OF TRANSPORTATION DATE  
 MARK LANCASTER, P.E.

REVISION	DESCRIPTION	MARK	DATE	APPROVED



COUNTY OF RIVERSIDE

**LOCAL FRONTAGE ROAD (52' R/W)**

STANDARD No. 107

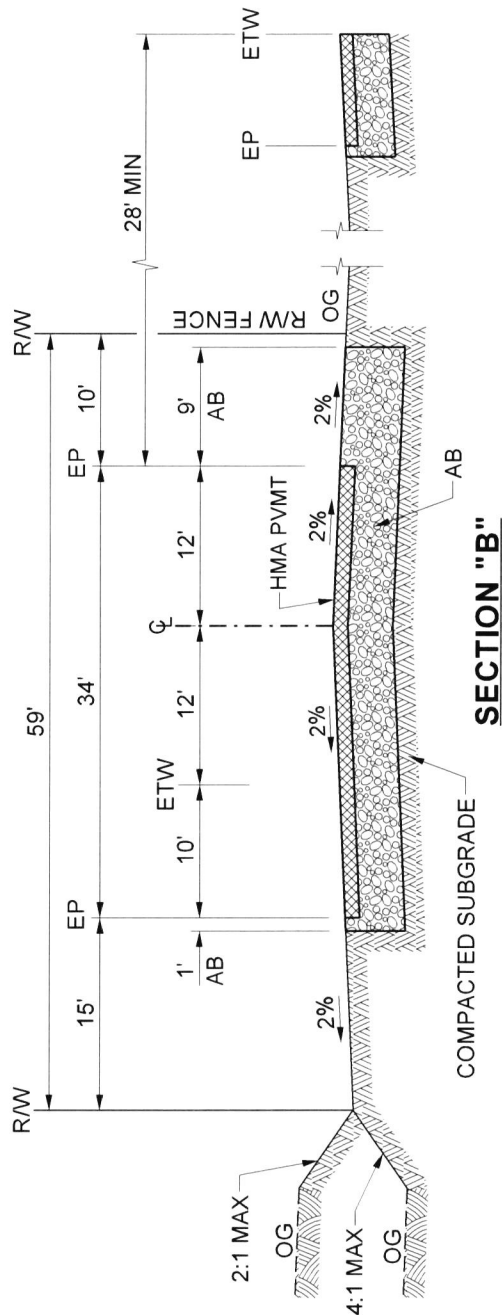
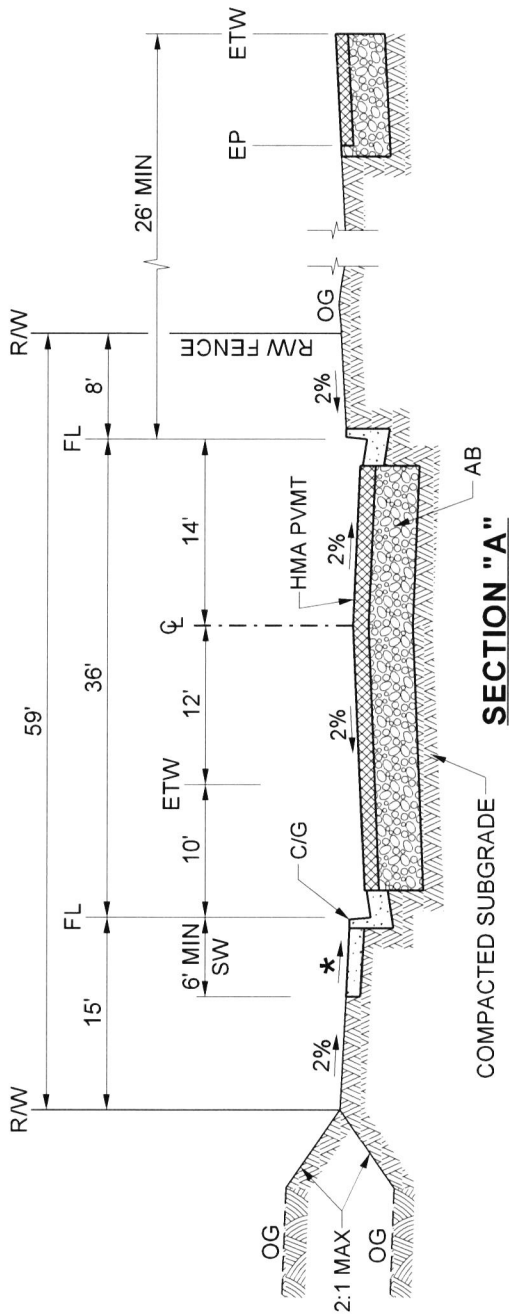

\* CROSS SLOPE OF SIDEWALK SHALL BE 1.5% (2.00% MAX AS-BUILT)

**NOTES:**

1. THICKNESS OF AB AND HMA TO BE DETERMINED BY SOIL TEST AT TIME OF GRADING OPERATIONS.
2. MINIMUM PAVING THICKNESS PER SPECIFICATIONS SECTION 8.07 OF THIS ORDINANCE.
3. CURB AND GUTTER TO BE TYPE "A-6" (STANDARD No. 200). 8" CURB IS NOT ALLOWED.
4. ROADWAY CROSS-SECTION LESS THAN 40 FT IN WIDTH IS LIMITED TO PARKING ON ONE SIDE OF THE STREET.

NOT TO SCALE

PREPARED UNDER THE SUPERVISION OF:

*Mark Lancaster*

11/30/22  
DATE

DIRECTOR OF TRANSPORTATION  
MARK LANCASTER, P.E.



COUNTY OF RIVERSIDE

**COLLECTOR  
FRONTAGE ROAD  
(59' R/W)**

**STANDARD No. 107A**

REVISION	DESCRIPTION	MARK	DATE	APPROVED

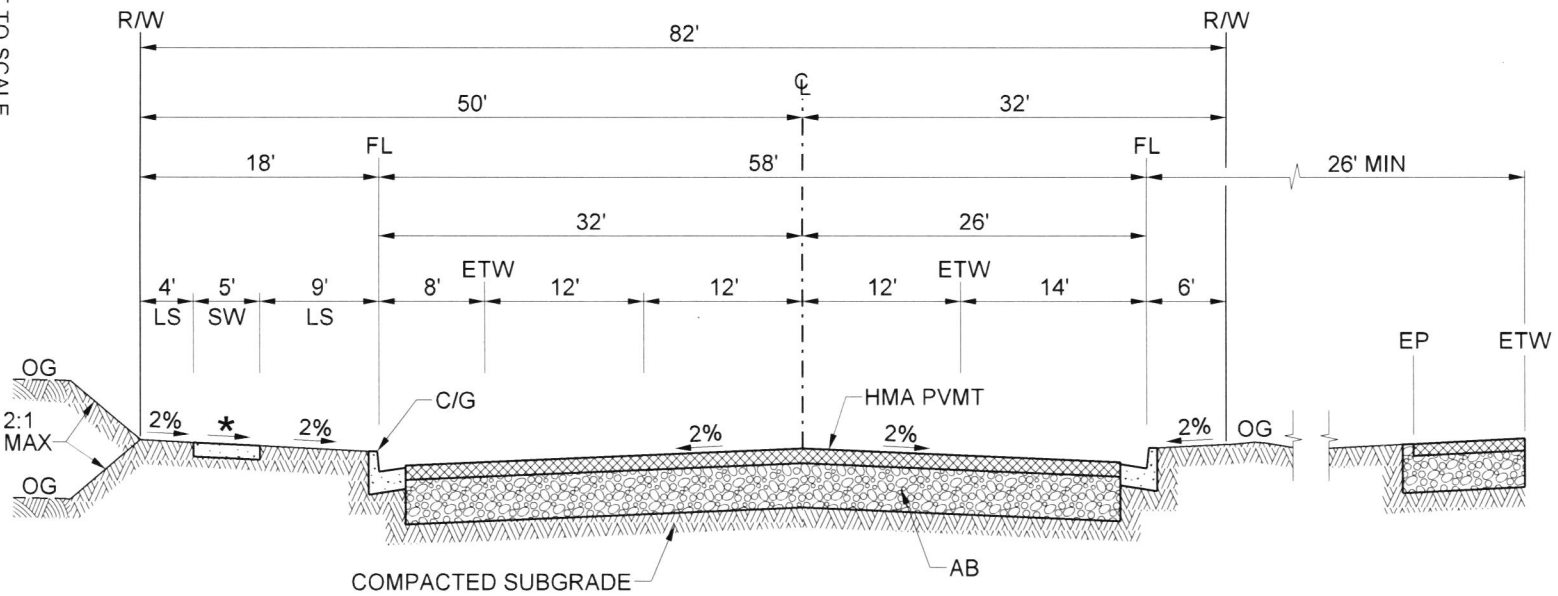

**SECTION**

\* CROSS SLOPE OF SIDEWALK SHALL BE 1.5% (2.00% MAX AS-BUILT)

**NOTES:**

1. THICKNESS OF AB AND HMA TO BE DETERMINED BY SOIL TEST AT TIME OF GRADING OPERATIONS.
2. MINIMUM PAVING THICKNESS PER SPECIFICATIONS SECTION 8.07 OF THIS ORDINANCE.
3. CURB AND GUTTER TO BE TYPE "A-6" (STANDARD No. 200). 8" CURB IS NOT ALLOWED.

NOT TO SCALE

PREPARED UNDER THE SUPERVISION OF:

*Mark Lancaster*

DIRECTOR OF TRANSPORTATION  
 MARK LANCASTER, P.E. DATE 11/30/22

REVISION DESCRIPTION MARK DATE APPROVED



COUNTY OF RIVERSIDE

SECONDARY  
 FRONTAGE ROAD  
 (82' R/W)

STANDARD No. 108

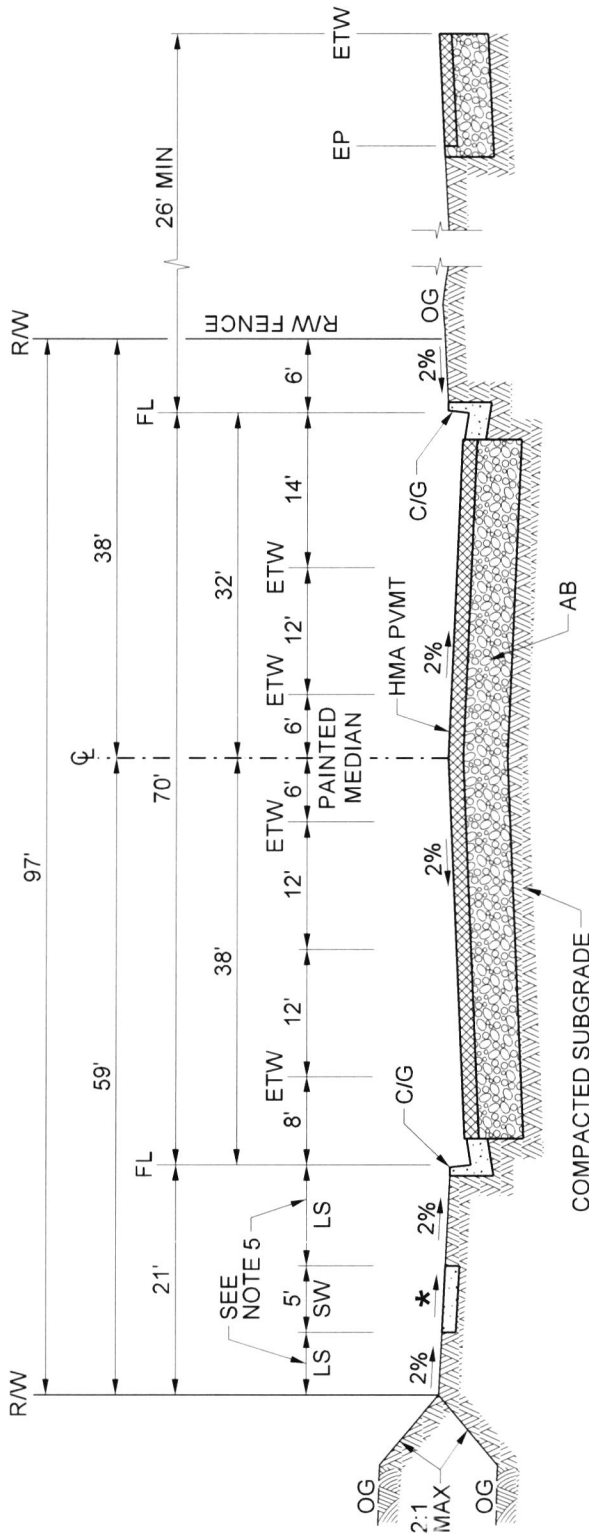

**SECTION**

\* CROSS SLOPE OF SIDEWALK SHALL BE 1.5% (2.00% MAX AS-BUILT)

**NOTES:**

1. THICKNESS OF AB AND HMA TO BE DETERMINED BY SOIL TEST AT TIME OF GRADING OPERATIONS.
2. MINIMUM PAVING THICKNESS PER SPECIFICATIONS SECTION 8.07 OF THIS ORDINANCE.
3. CURB AND GUTTER TO BE TYPE "A-8" (STANDARD No. 201). 6" CURB IS NOT ALLOWED.
4. DISTANCE FROM SIDEWALK TO RW, AND TO FLOWLINE, VARIES. SEE STANDARD No. 404 FOR DETAILS OF MEANDERING SIDEWALK.

NOT TO SCALE

PREPARED UNDER THE SUPERVISION OF:

*Mark Lancaster*

11/30/22  
DATE

DIRECTOR OF TRANSPORTATION  
MARK LANCASTER, P.E.



COUNTY OF RIVERSIDE

**MAJOR FRONTAGE ROAD (97' R/W)**

**STANDARD No. 109**

REVISION	DESCRIPTION	MARK	DATE	APPROVED

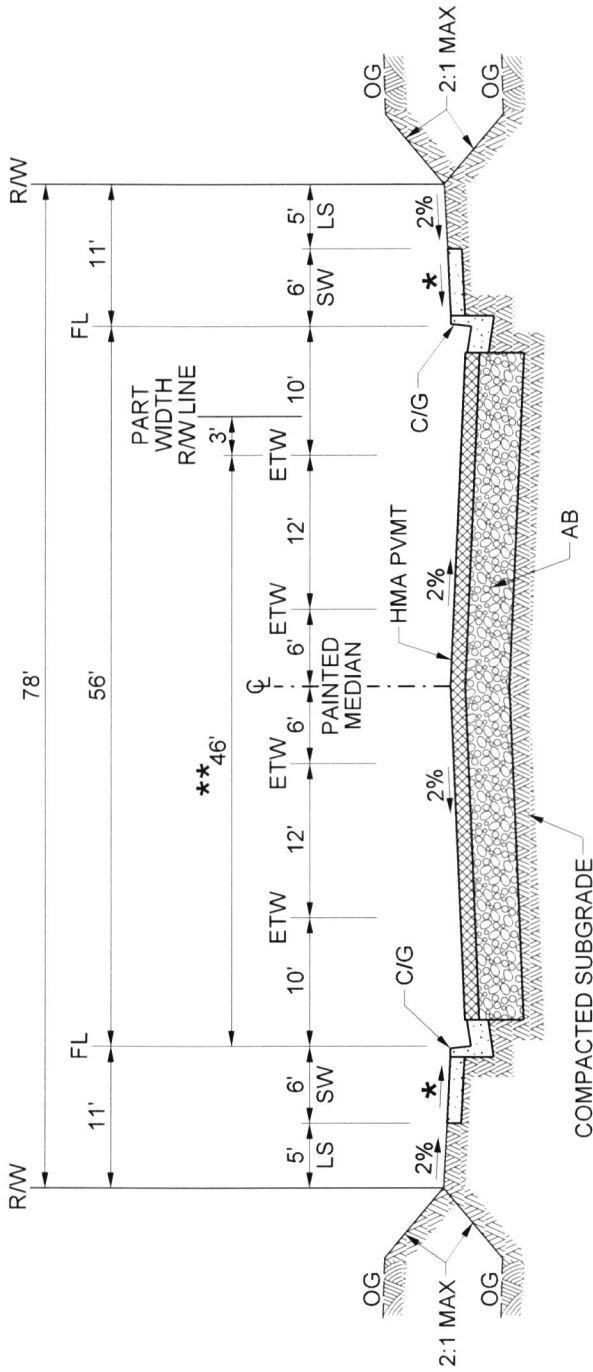

**SECTION**

\* CROSS SLOPE OF SIDEWALK SHALL BE 1.5% (2.00% MAX AS-BUILT)

\*\* PART-WIDTH STREET SECTION: 46' IMPROVEMENTS ON 60' RW

**NOTES:**

1. THICKNESS OF AB AND HMA TO BE DETERMINED BY SOIL TEST AT TIME OF GRADING OPERATIONS.
2. MINIMUM PAVING THICKNESS PER SPECIFICATIONS SECTION 8.07 OF THIS ORDINANCE.
3. ALL CURB AND GUTTER TO BE TYPE "A-6" (STANDARD No. 200) UNLESS OTHERWISE SPECIFIED.

NOT TO SCALE

PREPARED UNDER THE SUPERVISION OF:

*Mark Lancaster*

DIRECTOR OF TRANSPORTATION  
MARK LANCASTER, P.E.

11/30/22  
DATE

REVISION DESCRIPTION	MARK	DATE	APPROVED



COUNTY OF RIVERSIDE

**INDUSTRIAL  
COLLECTOR STREET  
(78' R/W)**

STANDARD No. 111

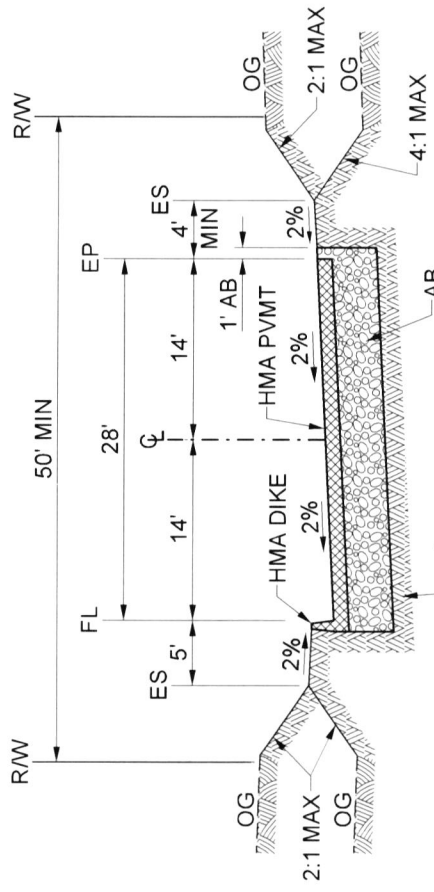

**\* SECTION "A" \***

FOR DRAINAGE CONTROL AS APPROVED BY THE DIRECTOR OF TRANSPORTATION

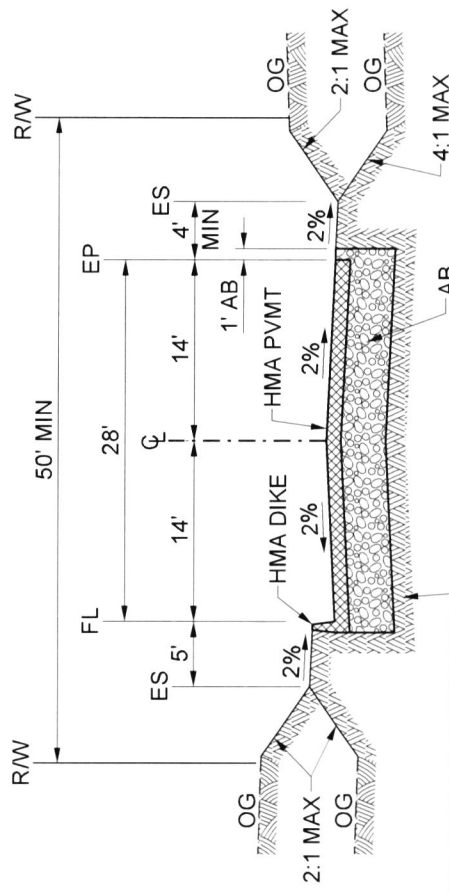

**SECTION "B"**

**NOTES:**

1. THIS STANDARD APPLIES IN AREAS AT AN ELEVATION OF 5000 FEET OR HIGHER.
2. THICKNESS OF AB AND HMA TO BE DETERMINED BY SOIL TEST AT TIME OF GRADING OPERATIONS.
3. MINIMUM PAVING THICKNESS PER SPECIFICATIONS SECTION 8.07 OF THIS ORDINANCE.
4. SEE STANDARD No. 212 FOR HMA DIKE DETAIL AND REQUIREMENTS. HMA DIKE MAY BE REQUIRED ON ONE OR BOTH SIDES.
5. GRADES SHALL NOT EXCEED 10%. GRADES UP TO 15% MAY BE APPROVED FOR DISTANCES NOT TO EXCEED 200'.

NOT TO SCALE

PREPARED UNDER THE SUPERVISION OF:

*Mark Lancaster*

DIRECTOR OF TRANSPORTATION  
MARK LANCASTER, P.E.

11/30/22  
DATE



COUNTY OF RIVERSIDE

**LOCAL MOUNTAIN  
RESIDENTIAL STREET  
(50' R/W)**

**STANDARD No. 112**

REVISION	DESCRIPTION	MARK	DATE	APPROVED

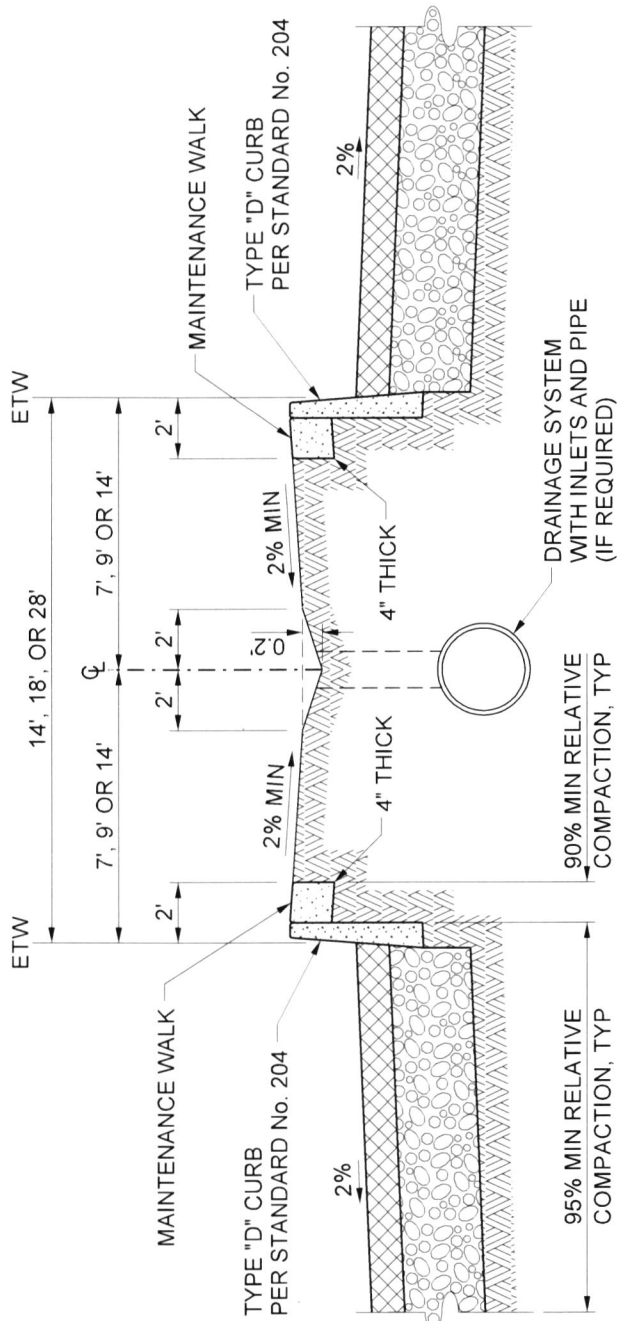

**NOTES:**

1. ALL LANDSCAPING AND IRRIGATION PLANS MUST BE APPROVED BY THE TRANSPORTATION DEPARTMENT.
2. CONTINUED MAINTENANCE OF PLANTED LANDSCAPING MUST BE GUARANTEED THROUGH A MAINTENANCE DISTRICT OR OTHER COUNTY APPROVED MECHANISM.
3. ANY IRRIGATION MUST BE PROVIDED BY A DRIP SYSTEM.
4. INSTALL 8" CURB AND GUTTER (STANDARD No. 201) IN PLACE OF TYPE "D" CURB WHEN FLOW LINE IS AGAINST MEDIAN IN CONDITIONS OF SUPERELEVATION.
5. RELATIVE COMPACTION SHALL BE A MINIMUM OF 95% UNDER ROADWAY AND CURB (AND GUTTER) AND 90% UNDER MAINTENANCE WALKS.
6. WHEN ABUTTING SOIL HAS A HIGH SULFATE CONTENT, USE A MODIFIED CONCRETE MIX AND PLACE 6" MIN CLASS 2 AGGREGATE BASE AND 6 MIL PLASTIC SHEETING UNDER AND AROUND ALL SIDES OF CONCRETE IMPROVEMENTS. FOR EXPANSIVE SOIL, PLACE 6" MIN CLASS 2 AGGREGATE BASE UNDER CONCRETE IMPROVEMENTS AS DIRECTED BY THE ENGINEER. SEE SPECIFICATIONS SECTIONS 16.03 & 16.04 AND STANDARD No. 401 FOR REFERENCE.
7. PLACE WEAKEND PLANE AND EXPANSION JOINTS IN CURB (AND GUTTER) AND MAINTENANCE WALK PER STANDARD No. 205.

NOT TO SCALE

PREPARED UNDER THE SUPERVISION OF:

*Mark Lancaster*  
 DIRECTOR OF TRANSPORTATION  
 MARK LANCASTER, P.E.

11/30/22  
 DATE

REVISION	DESCRIPTION	MARK	DATE	APPROVED

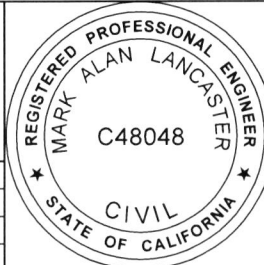

COUNTY OF RIVERSIDE

**LANDSCAPED MEDIAN**

**STANDARD No. 113**



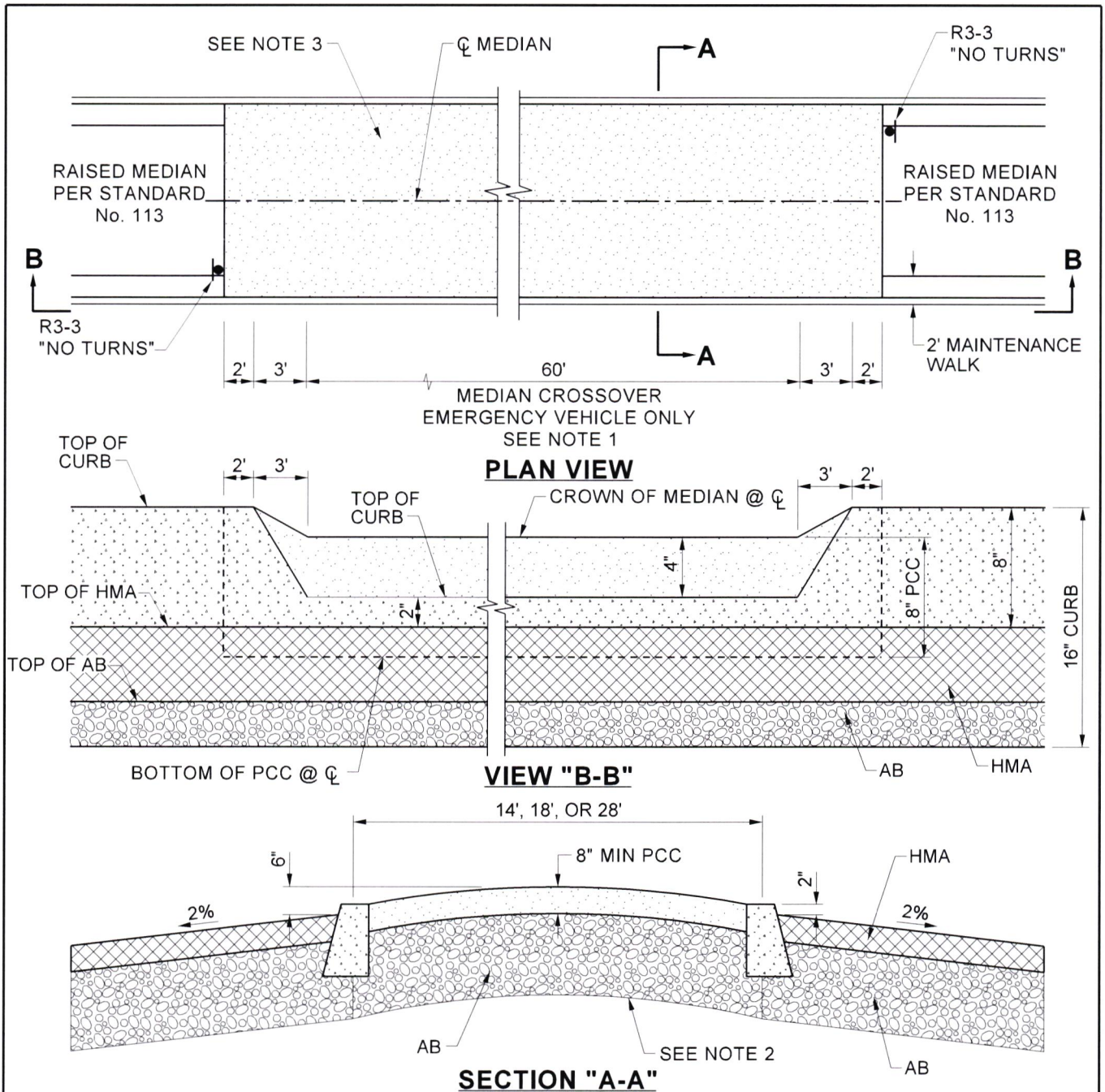

**NOTES:**

1. 60' OR AS APPROVED BY THE FIRE AND TRANSPORTATION DEPARTMENTS.
2. DESIGN PCC AND AB SECTION FOR 60,000 LB, 2 AXLE VEHICLE.
3. RED STAMPED CONCRETE OR EQUAL AS APPROVED BY THE FIRE AND TRANSPORTATION DEPARTMENTS.
4. RELATIVE COMPACTION OF SUBGRADE UNDER ROADWAY, CURB AND CROSSOVER MEDIAN SHALL BE 95% MINIMUM.

NOT TO SCALE

PREPARED UNDER THE SUPERVISION OF:

*Mark Lancaster*  
 DIRECTOR OF TRANSPORTATION  
 MARK LANCASTER, P.E.

11/30/22  
 DATE



COUNTY OF RIVERSIDE

**CROSSOVER MEDIAN**

**STANDARD No. 113A**

REVISION	DESCRIPTION	MARK	DATE	APPROVED



**NOTES:**

- (a) MINIMUM PAVING THICKNESS PER SPECIFICATIONS SECTION 8.07 OF THIS ORDINANCE.
- (b) ROADWAY DESIGN LESS THAN SHOWN REQUIRES TRANSPORTATION DEPARTMENT APPROVAL.
- (c) PART-WIDTH STREET SECTIONS SHALL BE IMPROVED AND R/W CONVEYED AS SHOWN ON TYPICAL STREET SECTIONS.
- (d) DIRECT ACCESS PROHIBITED.
- (e) RESIDENTIAL ACCESS PROHIBITED. COMMERCIAL/INDUSTRIAL DRIVEWAY ACCESS AS DETERMINED BY THE DIRECTOR OF TRANSPORTATION.
- (f) FOR DEVELOPMENTS THAT HAVE A SIGNIFICANT AMOUNT OF TRUCK TRAFFIC, THE DEVELOPER MAY BE REQUIRED TO PERFORM A TRAFFIC ANALYSIS TO DETERMINE THE APPROPRIATE TRAFFIC INDEX FOR THE ROADWAY IMPROVEMENTS.
- (g) MAY USE AS A CUL-DE-SAC IN INDUSTRIAL OR COMMERCIAL USE AREAS, INTERSECTION INTERVAL NOT TO EXCEED 660' IN LENGTH.
- (h) ADDITIONAL R/W REQUIRED AT INTERSECTIONS TO ACCOMMODATE TURN LANES PER STANDARD No's. 81, 82, 84, 86 & 91-94. ADDITIONAL R/W MAY BE REQUIRED ON OPPOSITE SIDE OF INTERSECTION TO ALIGN THROUGH LANES.
- (i) FOR ACCESS ROADS, IF THE ULTIMATE ROAD CLASSIFICATION IS A GENERAL PLAN HIGHWAY, THE TRAFFIC INDEX REQUIREMENT IS 7.0. THE MINIMUM R/W WIDTH FOR ACCESS ROADS IS 60 FEET.
- (j) IF BOTH INTERSECTING STREETS HAVE A WIDTH LESS THAN STANDARD No. 111 (INDUSTRIAL COLLECTOR, 78' R/W), THEN THE CURB RETURN RADIUS WILL BE 25'. IF EITHER STREET HAS A WIDTH GREATER THAN OR EQUAL TO STANDARD No. 111 THEN THE CURB RETURN RADIUS WILL BE 35'. SEE STANDARD No. 805 CORNER CUTBACK R/W REQUIREMENTS.

NOT TO SCALE

PREPARED UNDER THE SUPERVISION OF:

*Mark Lancaster* 11/30/22  
 DIRECTOR OF TRANSPORTATION DATE  
 MARK LANCASTER, P.E.



COUNTY OF RIVERSIDE

**ROADWAY DESIGN REQUIREMENTS**

**STANDARD No. 114 (2 OF 2)**

REVISION DESCRIPTION	MARK	DATE	APPROVED

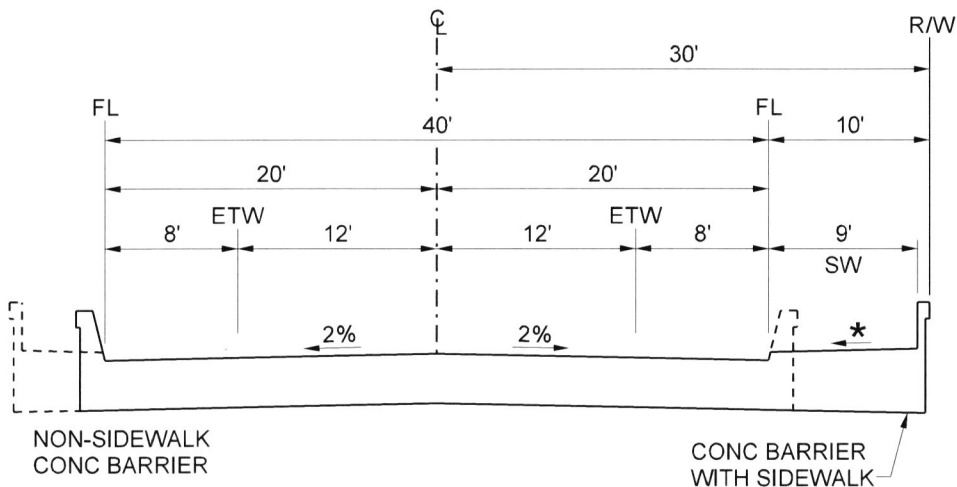

**LOCAL STREET BRIDGE**

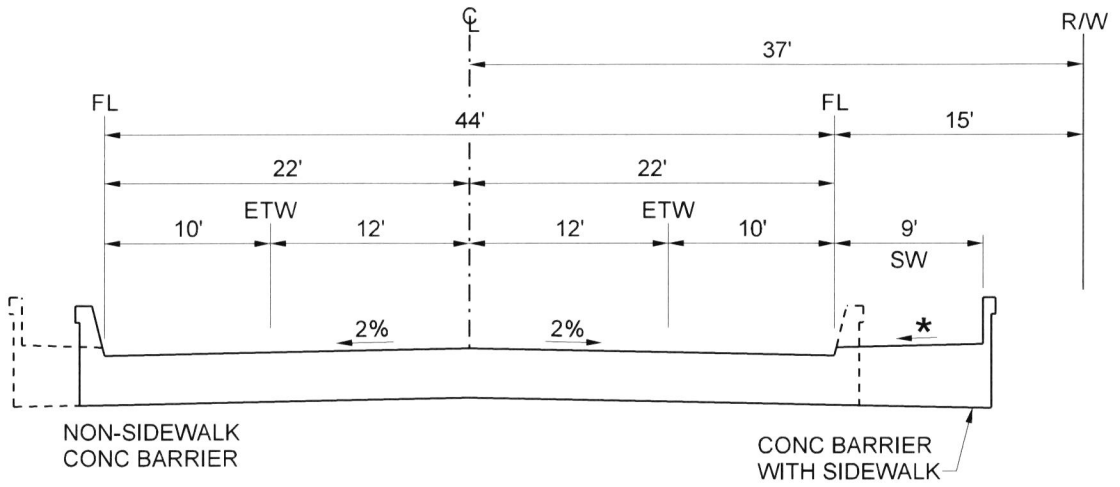

**COLLECTOR STREET BRIDGE**

\*CROSS SLOPE OF SIDEWALK SHALL BE 1.5% (2.00% MAX AS-BUILT)

**NOTES:**

1. BRIDGE TYPE TO BE APPROVED BY THE TRANSPORTATION DEPARTMENT.
2. RAISED SIDEWALK TO BE PROVIDED. NON-SIDEWALK CONCRETE BARRIER TO BE USED ONLY IF APPROVED BY THE DIRECTOR OF TRANSPORTATION.
3. CONCRETE BARRIER SHALL BE TO CALTRANS STANDARDS OR AS APPROVED BY THE DIRECTOR OF TRANSPORTATION.
4. REFER TO COUNTY OF RIVERSIDE BRIDGE DESIGN MANUAL FOR ADDITIONAL INFORMATION.

NOT TO SCALE

PREPARED UNDER THE SUPERVISION OF:

*Mark Lancaster* 11/30/22  
 DIRECTOR OF TRANSPORTATION DATE  
 MARK LANCASTER, P.E.

REVISION	DESCRIPTION	MARK	DATE	APPROVED

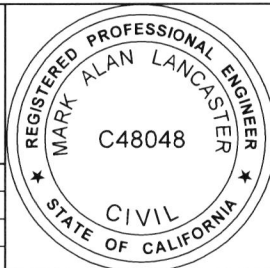

COUNTY OF RIVERSIDE

**LOCAL AND COLLECTOR STREET BRIDGE**

**STANDARD No. 115**

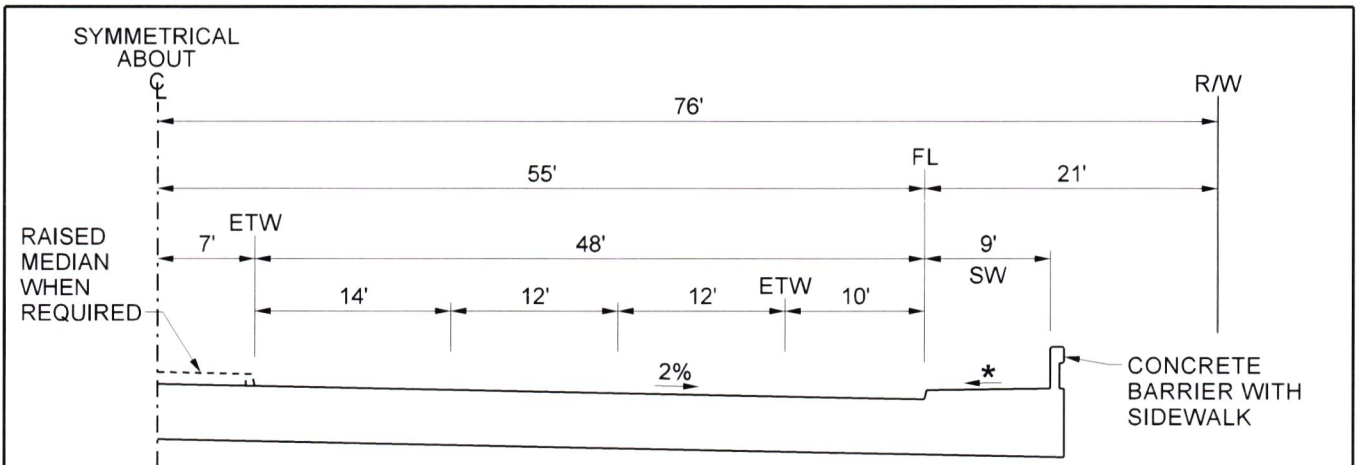

**ULTIMATE SECTION**

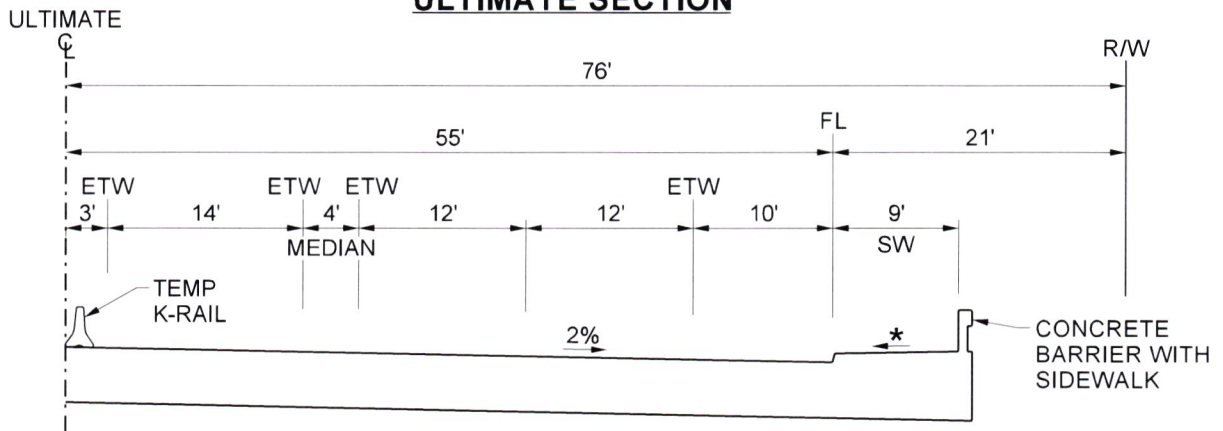

**3 LANES**

INTERIM STRIPING LAYOUT  
(INITIAL PHASE)

\* CROSS SLOPE OF SIDEWALK SHALL BE 1.5% (2.00% MAX AS-BUILT)

**NOTES:**

1. ULTIMATE TYPICAL BRIDGE SECTIONS TO BE CONSISTENT WITH THE APPROACH ROAD SECTION AS APPROVED BY THE TRANSPORTATION DEPARTMENT.
2. BRIDGE TYPE TO BE APPROVED BY THE TRANSPORTATION DEPARTMENT.
3. CURBED MEDIAN TO BE USED ONLY WHEN APPROACHING HIGHWAY HAS A RAISED MEDIAN. MEDIAN WIDTH MAY VARY WITH RAISED CURB.
4. MEDIAN WIDTH SUBJECT TO VARIATION DEPENDING ON INTERSECTION PROXIMITY.
5. RAISED SIDEWALK TO BE PROVIDED. NON-SIDEWALK CONCRETE BARRIER TO BE USED ONLY IF APPROVED BY THE DIRECTOR OF TRANSPORTATION.
6. CONCRETE BARRIER SHALL BE TO CALTRANS STANDARDS OR AS APPROVED BY THE DIRECTOR OF TRANSPORTATION.
7. REFER TO COUNTY OF RIVERSIDE BRIDGE DESIGN MANUAL FOR ADDITIONAL INFORMATION.

NOT TO SCALE

PREPARED UNDER THE SUPERVISION OF:

*Mark Lancaster*  
 DIRECTOR OF TRANSPORTATION  
 MARK LANCASTER, P.E.  
 11/30/22  
 DATE



COUNTY OF RIVERSIDE

**URBAN ARTERIAL  
HIGHWAY BRIDGE**

**STANDARD No. 116**

REVISION	DESCRIPTION	MARK	DATE	APPROVED

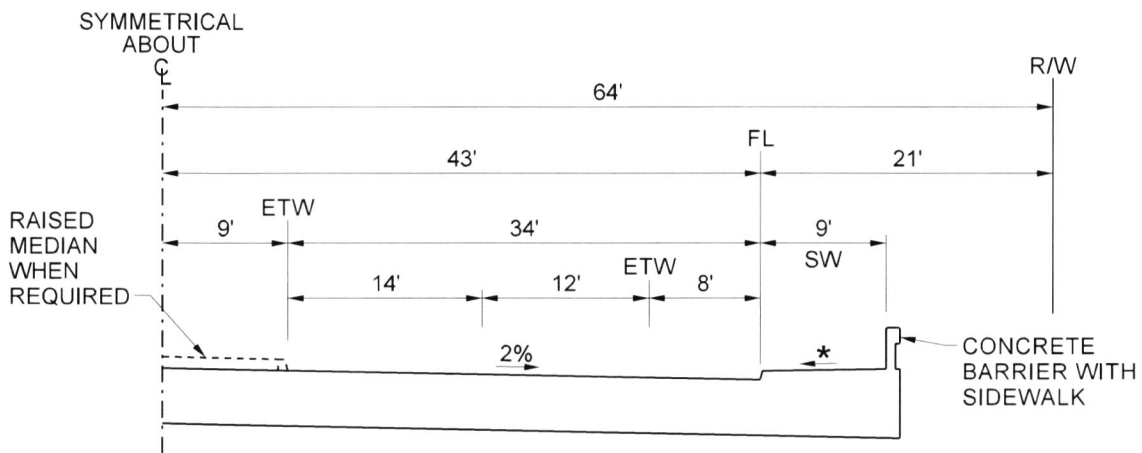

**ULTIMATE SECTION**

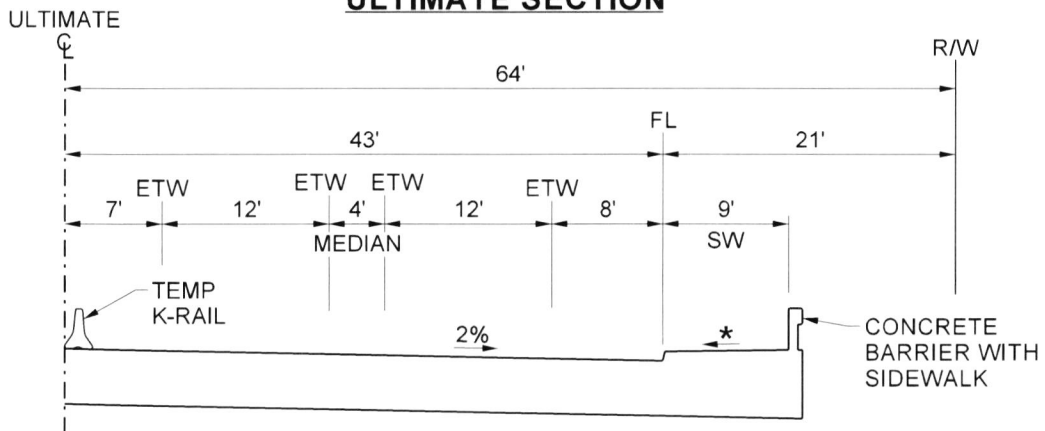

**2 LANES**

INTERIM STRIPING LAYOUT  
(INITIAL PHASE)

\* CROSS SLOPE OF SIDEWALK SHALL BE 1.5% (2.00% MAX AS-BUILT)

**NOTES:**

1. ULTIMATE TYPICAL BRIDGE SECTIONS TO BE CONSISTENT WITH THE APPROACH ROAD SECTION AS APPROVED BY THE TRANSPORTATION DEPARTMENT.
2. BRIDGE TYPE TO BE APPROVED BY THE TRANSPORTATION DEPARTMENT.
3. CURBED MEDIAN TO BE USED ONLY WHEN APPROACHING HIGHWAY HAS A RAISED MEDIAN. MEDIAN WIDTH MAY VARY WITH RAISED CURB.
4. MEDIAN WIDTH SUBJECT TO VARIATION DEPENDING ON INTERSECTION PROXIMITY.
5. RAISED SIDEWALK TO BE PROVIDED. NON-SIDEWALK CONCRETE BARRIER TO BE USED ONLY IF APPROVED BY THE DIRECTOR OF TRANSPORTATION.
6. CONCRETE BARRIER SHALL BE TO CALTRANS STANDARDS OR AS APPROVED BY THE DIRECTOR OF TRANSPORTATION.
7. REFER TO COUNTY OF RIVERSIDE BRIDGE DESIGN MANUAL FOR ADDITIONAL INFORMATION.

NOT TO SCALE

PREPARED UNDER THE SUPERVISION OF:

*Mark Lancaster* 11/30/22  
 DIRECTOR OF TRANSPORTATION DATE  
 MARK LANCASTER, P.E.

REVISION	DESCRIPTION	MARK	DATE	APPROVED



COUNTY OF RIVERSIDE

**ARTERIAL  
HIGHWAY BRIDGE**

**STANDARD No. 117**

SYMMETRICAL ABOUT

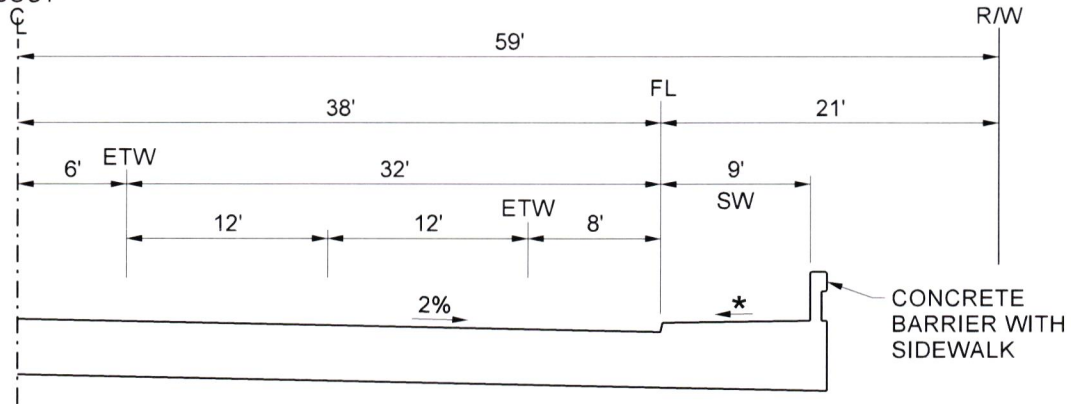

**ULTIMATE SECTION**

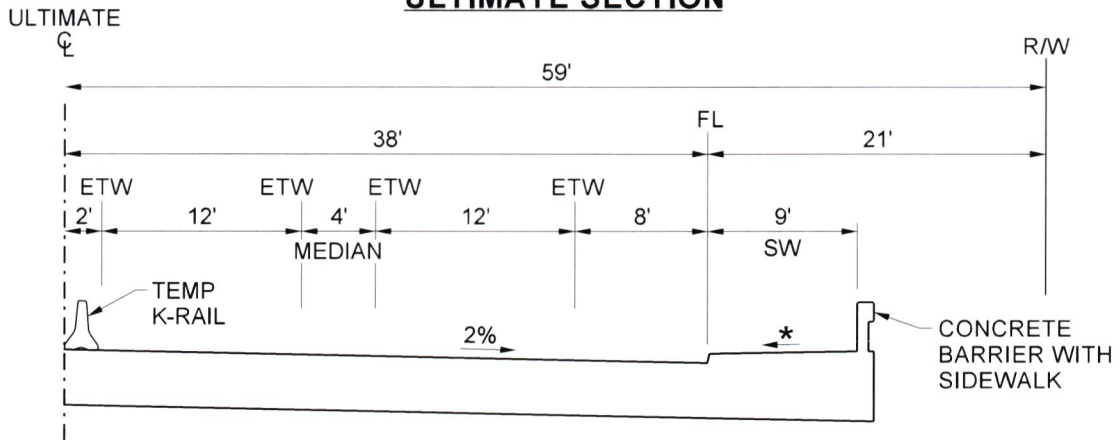

**2 LANES**

INTERIM STRIPING LAYOUT  
(INITIAL PHASE)

\* CROSS SLOPE OF SIDEWALK SHALL BE 1.5% (2.00% MAX AS-BUILT)

**NOTES:**

1. ULTIMATE TYPICAL BRIDGE SECTIONS TO BE CONSISTENT WITH THE APPROACH ROAD SECTION AS APPROVED BY THE TRANSPORTATION DEPARTMENT.
2. BRIDGE TYPE TO BE APPROVED BY THE TRANSPORTATION DEPARTMENT.
3. CURBED MEDIAN TO BE USED ONLY WHEN APPROACHING HIGHWAY HAS A RAISED MEDIAN. MEDIAN WIDTH MAY VARY WITH RAISED CURB.
4. MEDIAN WIDTH SUBJECT TO VARIATION DEPENDING ON INTERSECTION PROXIMITY.
5. RAISED SIDEWALK TO BE PROVIDED. NON-SIDEWALK CONCRETE BARRIER TO BE USED ONLY IF APPROVED BY THE DIRECTOR OF TRANSPORTATION.
6. CONCRETE BARRIER SHALL BE TO CALTRANS STANDARDS OR AS APPROVED BY THE DIRECTOR OF TRANSPORTATION.
7. REFER TO COUNTY OF RIVERSIDE BRIDGE DESIGN MANUAL FOR ADDITIONAL INFORMATION.

NOT TO SCALE

PREPARED UNDER THE SUPERVISION OF:

*Mark Lancaster*

DIRECTOR OF TRANSPORTATION  
MARK LANCASTER, P.E.

11/30/22  
DATE



COUNTY OF RIVERSIDE

**MAJOR  
HIGHWAY BRIDGE**

**STANDARD No. 118**

REVISION	DESCRIPTION	MARK	DATE	APPROVED

SYMMETRICAL ABOUT

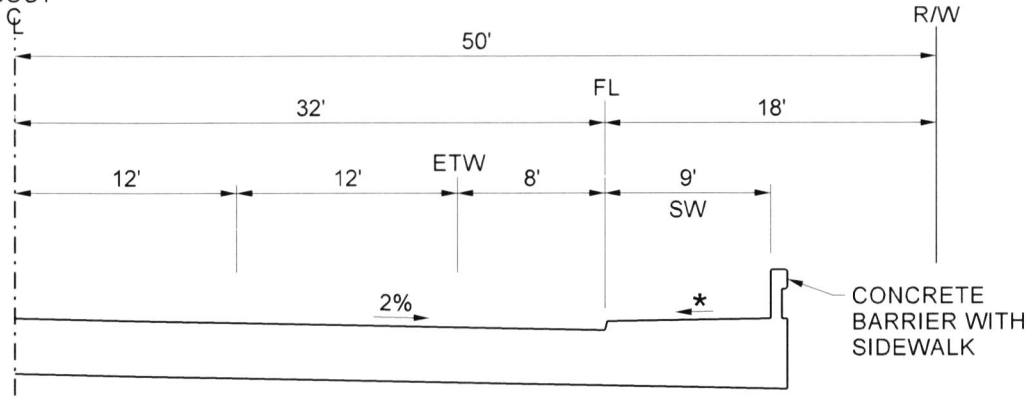

**ULTIMATE SECTION**

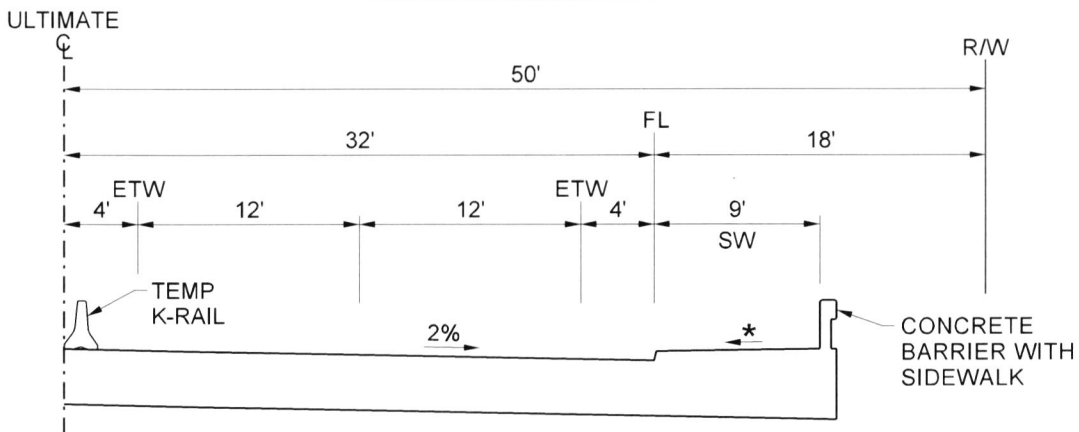

**2 LANES**

INTERIM STRIPING LAYOUT  
(INITIAL PHASE)

\*CROSS SLOPE OF SIDEWALK SHALL BE 1.5% (2.00% MAX AS-BUILT)

**NOTES:**

1. ULTIMATE TYPICAL BRIDGE SECTIONS TO BE CONSISTENT WITH THE APPROACH ROAD SECTION AS APPROVED BY THE TRANSPORTATION DEPARTMENT.
2. BRIDGE TYPE TO BE APPROVED BY THE TRANSPORTATION DEPARTMENT.
3. RAISED SIDEWALK TO BE PROVIDED. NON-SIDEWALK CONCRETE BARRIER TO BE USED ONLY IF APPROVED BY THE DIRECTOR OF TRANSPORTATION.
4. CONCRETE BARRIER SHALL BE TO CALTRANS STANDARDS OR AS APPROVED BY THE DIRECTOR OF TRANSPORTATION.
5. REFER TO COUNTY OF RIVERSIDE BRIDGE DESIGN MANUAL FOR ADDITIONAL INFORMATION.

NOT TO SCALE

PREPARED UNDER THE SUPERVISION OF:

*Mark Lancaster*  
 DIRECTOR OF TRANSPORTATION  
 MARK LANCASTER, P.E.

11/30/22  
 DATE



COUNTY OF RIVERSIDE

**SECONDARY  
HIGHWAY BRIDGE**

**STANDARD No. 119**

REVISION	DESCRIPTION	MARK	DATE	APPROVED



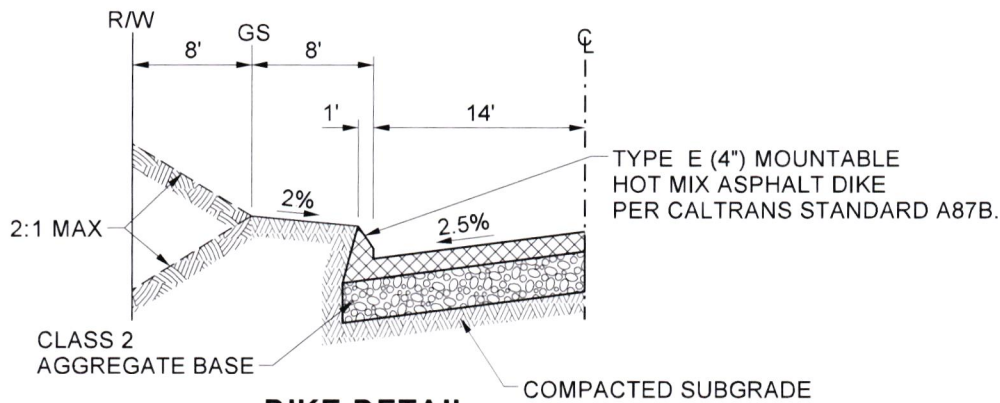
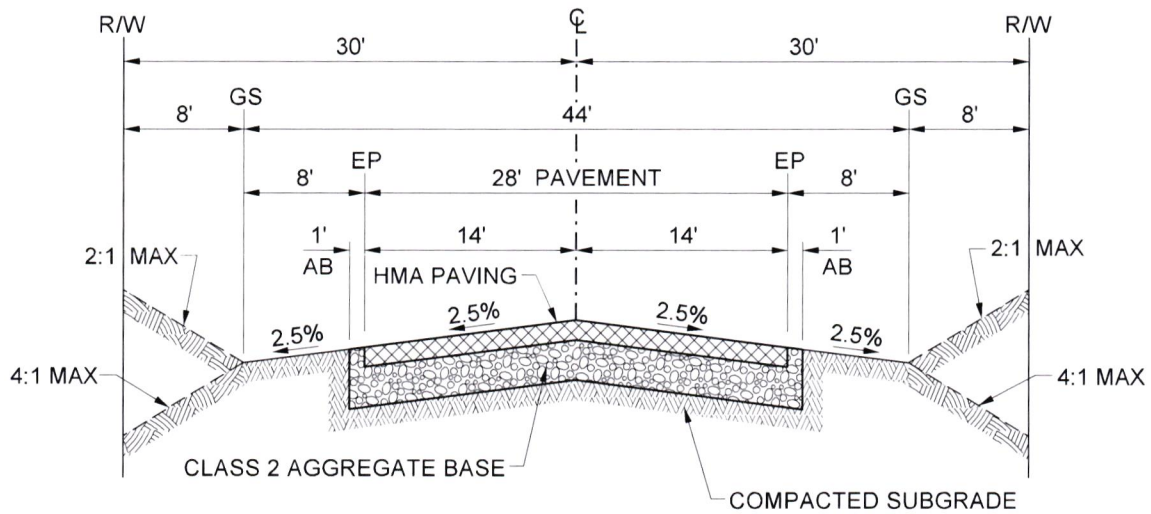

**DIKE DETAIL**  
SEE NOTE 3

**SERVING 21 THROUGH 49 LOTS**  
**1/2 ACRE GROSS MINIMUM LOT SIZE**

**NOTES:**

1. THICKNESS OF AB AND HMA TO BE DETERMINED BY SOIL TEST AT TIME OF GRADING OPERATIONS.
2. MINIMUM THICKNESS FOR HMA IS 0.25'; FOR AGGREGATE BASE IS 0.50'.
3. TO CONTROL DRAINAGE, PREVENT EROSION OR IF THE ROADWAY GRADIENT IS 6% OR GREATER, MOUNTABLE HMA DIKES SHALL BE REQUIRED. MOUNTABLE HMA DIKES AND WIDER PAVEMENT MAY BE REQUIRED FOR SAFETY, DRAINAGE, AND/OR CONTINUITY AS DETERMINED BY THE TRANSPORTATION DEPARTMENT.
4. THIS RURAL ROAD STANDARD SHALL BE APPLICABLE IN THE FOLLOWING AREAS: LAKE MATHEWS COMMUNITY PLAN (CSA 128) AND COUNTY SERVICE AREAS NUMBERED 41, 86, 104, 105, 108, 117, 124, AND 149 OR IF CONDITIONED BY THE TRANSPORTATION DEPARTMENT.
5. THE MINIMUM RADII, MAXIMUM GRADE PERCENTAGE, INTERSECTION INTERVALS, AND ALL OTHER DESIGN STANDARDS EXCEPT PAVEMENT WIDTH AND R/W SHALL BE THE SAME AS THOSE FOR A "LOCAL STREET" AS REQUIRED BY STANDARD No. 114.

NOT TO SCALE

PREPARED UNDER THE SUPERVISION OF:

*Mark Lancaster*  
 DIRECTOR OF TRANSPORTATION  
 MARK LANCASTER, P.E.  
 11/30/22  
 DATE

REVISION	DESCRIPTION	MARK	DATE	APPROVED



COUNTY OF RIVERSIDE

**COLLECTOR  
RURAL ROAD  
(60' R/W)**  
(SEE NOTE 4)

**STANDARD No. 136**

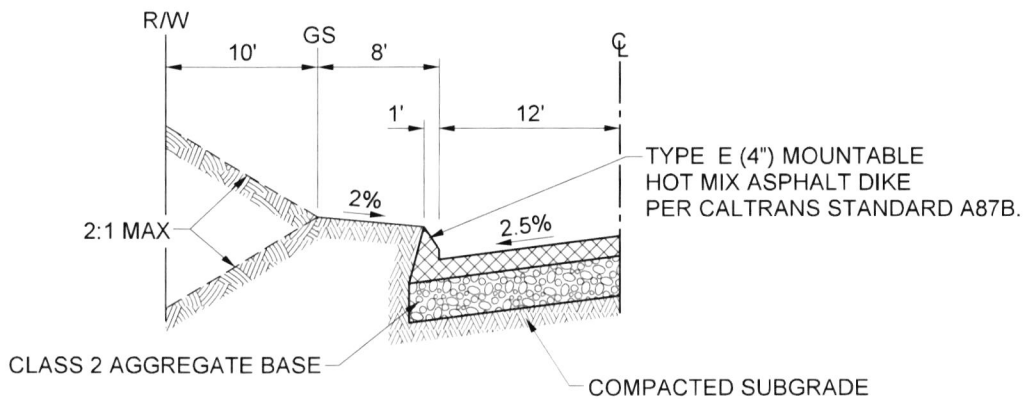
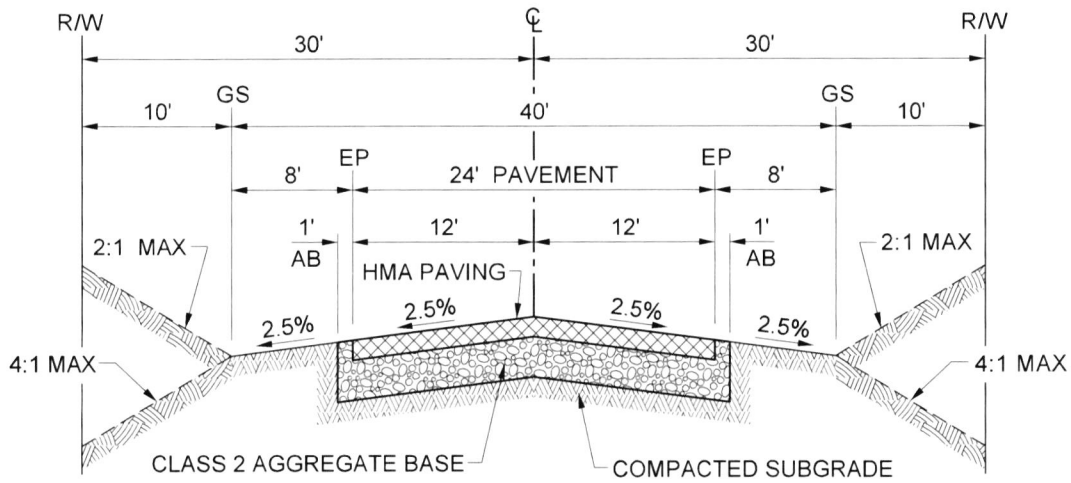

**DIKE DETAIL**

SEE NOTE 3

**SERVING 20 OR FEWER LOTS  
2 ACRE GROSS MINIMUM LOT SIZE**

**NOTES:**

1. THICKNESS OF AB AND HMA TO BE DETERMINED BY SOIL TEST AT TIME OF GRADING OPERATIONS.
2. MINIMUM THICKNESS FOR HMA IS 0.25'; FOR AGGREGATE BASE IS 0.50'.
3. TO CONTROL DRAINAGE, PREVENT EROSION OR IF THE ROADWAY GRADIENT IS 6% OR GREATER, MOUNTABLE HMA DIKES SHALL BE REQUIRED. MOUNTABLE HMA DIKES AND WIDER PAVEMENT MAY BE REQUIRED FOR SAFETY, DRAINAGE, AND/OR CONTINUITY AS DETERMINED BY THE TRANSPORTATION DEPARTMENT.
4. THIS RURAL ROAD STANDARD SHALL BE APPLICABLE IN THE FOLLOWING AREAS: LAKE MATHEWS COMMUNITY PLAN (CSA 128) AND COUNTY SERVICE AREAS NUMBERED 41, 86, 104, 105, 108, 117, 124, AND 149.
5. THE MINIMUM RADII, MAXIMUM GRADE PERCENTAGE, INTERSECTION INTERVALS, AND ALL OTHER DESIGN STANDARDS EXCEPT PAVEMENT WIDTH AND R/W SHALL BE THE SAME AS THOSE FOR A "LOCAL STREET" AS REQUIRED BY STANDARD No. 114.

NOT TO SCALE

PREPARED UNDER THE SUPERVISION OF:

*Mark Lancaster*  
 DIRECTOR OF TRANSPORTATION  
 MARK LANCASTER, P.E.  
 11/30/22  
 DATE

REVISION	DESCRIPTION	MARK	DATE	APPROVED

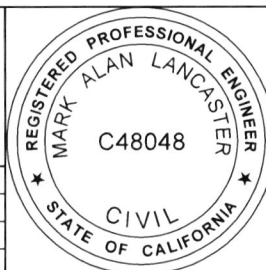

COUNTY OF RIVERSIDE

**RESIDENTIAL  
RURAL ROAD  
(60' R/W)**

(SEE NOTE 4)

**STANDARD No. 138**

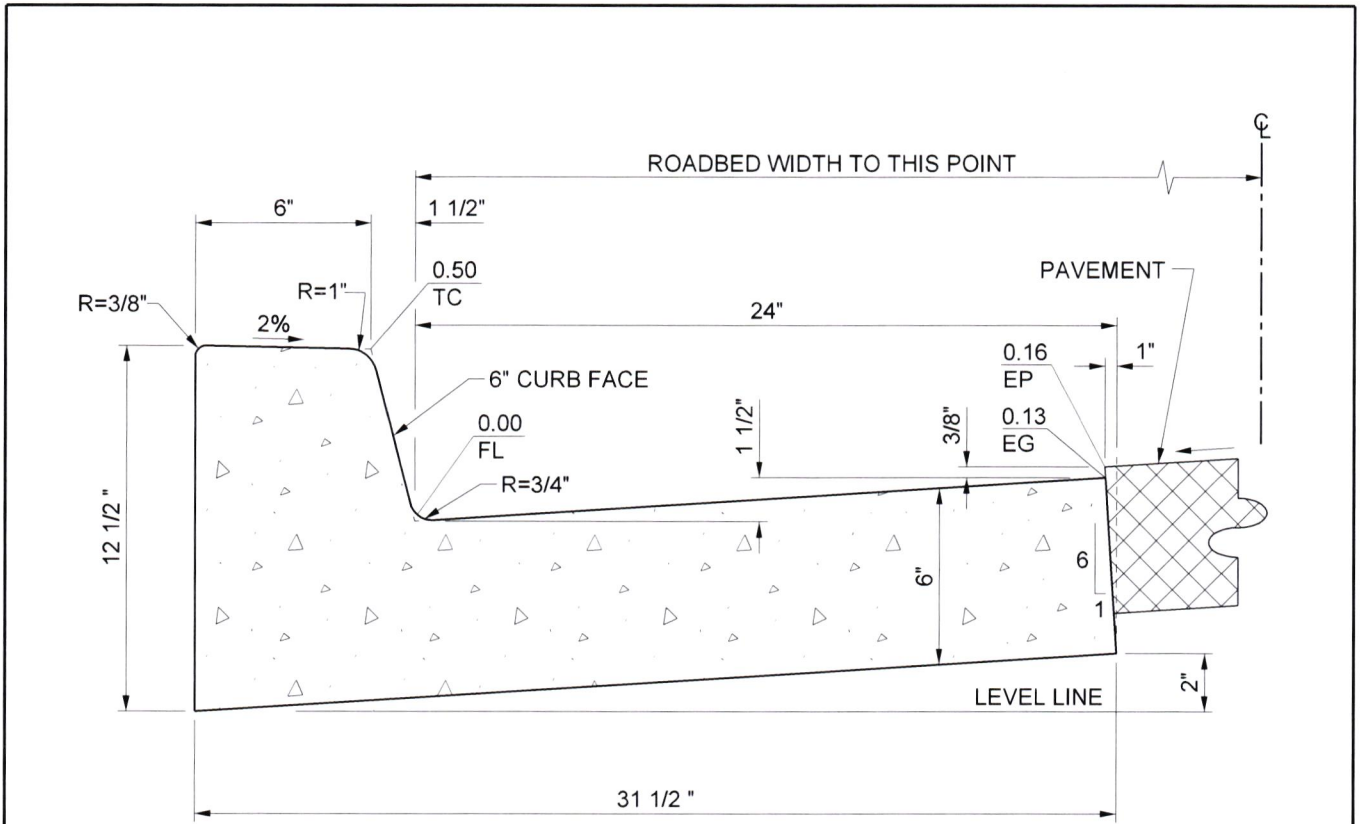

**MINIMUM CEMENTITIOUS MATERIAL CONTENT = 505 LB / CU YD**

1.601 CU FT / LF  
 1 CU YD = 16.86 LF

**NOTES:**

1. RELATIVE COMPACTION OF SUBGRADE UNDER CURB AND GUTTER SHALL BE 95% MINIMUM.
2. WHEN ABUTTING SOIL HAS A HIGH SULFATE CONTENT, USE A MODIFIED CONCRETE MIX AND PLACE 6" MIN CLASS 2 AGGREGATE BASE AND 6 MIL PLASTIC SHEETING UNDER AND AROUND ALL SIDES OF CONCRETE IMPROVEMENTS. FOR EXPANSIVE SOIL, PLACE 6" MIN CLASS 2 AGGREGATE BASE UNDER CONCRETE IMPROVEMENTS AS DIRECTED BY THE ENGINEER. SEE SPECIFICATIONS SECTIONS 16.03 & 16.04 AND STANDARD No. 401 FOR REFERENCE.

NOT TO SCALE

PREPARED UNDER THE SUPERVISION OF:

*Mark Lancaster*

11/30/22  
 DATE

DIRECTOR OF TRANSPORTATION  
 MARK LANCASTER, P.E.



COUNTY OF RIVERSIDE

**TYPE A-6  
 CURB AND GUTTER  
 6" CURB FACE**

**STANDARD No. 200**

REVISION	DESCRIPTION	MARK	DATE	APPROVED

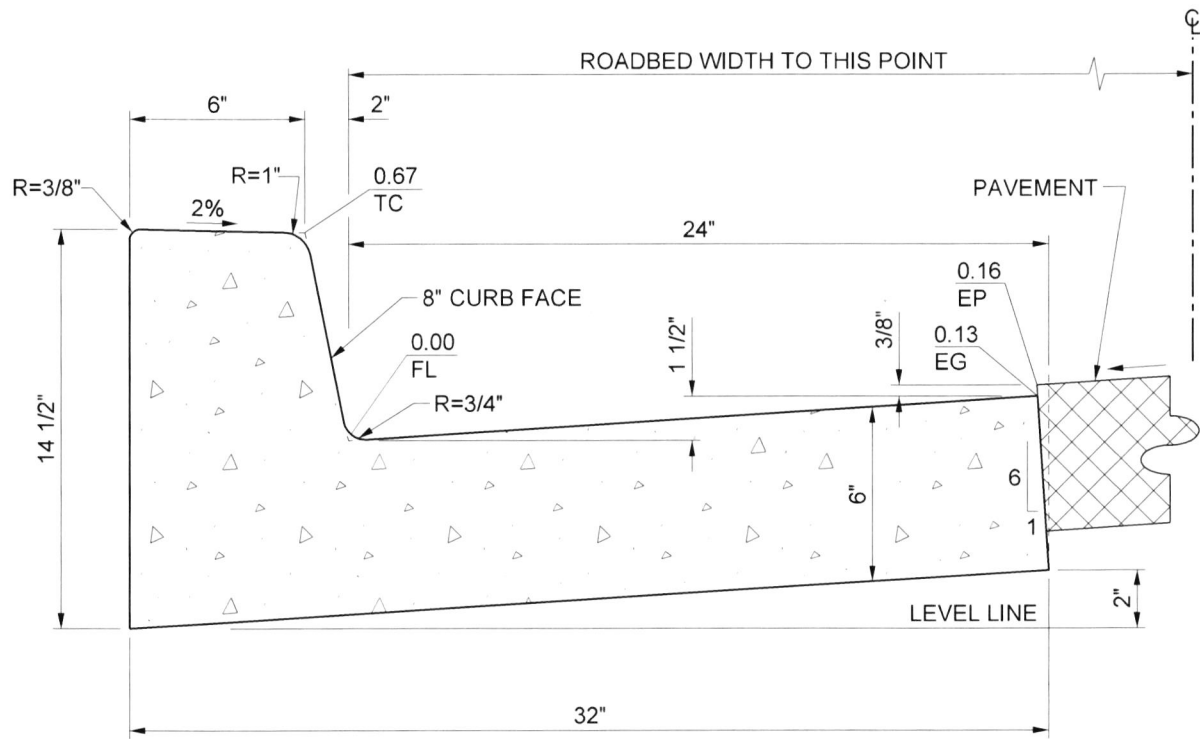

**MINIMUM CEMENTITIOUS MATERIAL CONTENT = 505 LB / CU YD**

1.73 CU FT / LF  
 1 CU YD = 15.60 LF

**NOTES:**

1. RELATIVE COMPACTION OF SUBGRADE UNDER CURB AND GUTTER SHALL BE 95% MINIMUM.
2. WHEN ABUTTING SOIL HAS A HIGH SULFATE CONTENT, USE A MODIFIED CONCRETE MIX AND PLACE 6" MIN CLASS 2 AGGREGATE BASE AND 6 MIL PLASTIC SHEETING UNDER AND AROUND ALL SIDES OF CONCRETE IMPROVEMENTS. FOR EXPANSIVE SOIL, PLACE 6" MIN CLASS 2 AGGREGATE BASE UNDER CONCRETE IMPROVEMENTS AS DIRECTED BY THE ENGINEER. SEE SPECIFICATIONS SECTIONS 16.03 & 16.04 AND STANDARD No. 401 FOR REFERENCE.

NOT TO SCALE

PREPARED UNDER THE SUPERVISION OF:

*Mark Lancaster* 11/30/22  
 DIRECTOR OF TRANSPORTATION DATE  
 MARK LANCASTER, P.E.

REVISION	DESCRIPTION	MARK	DATE	APPROVED

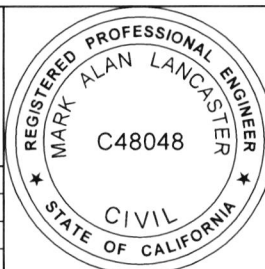

COUNTY OF RIVERSIDE

**TYPE A-8  
 CURB AND GUTTER  
 8" CURB FACE**

**STANDARD No. 201**

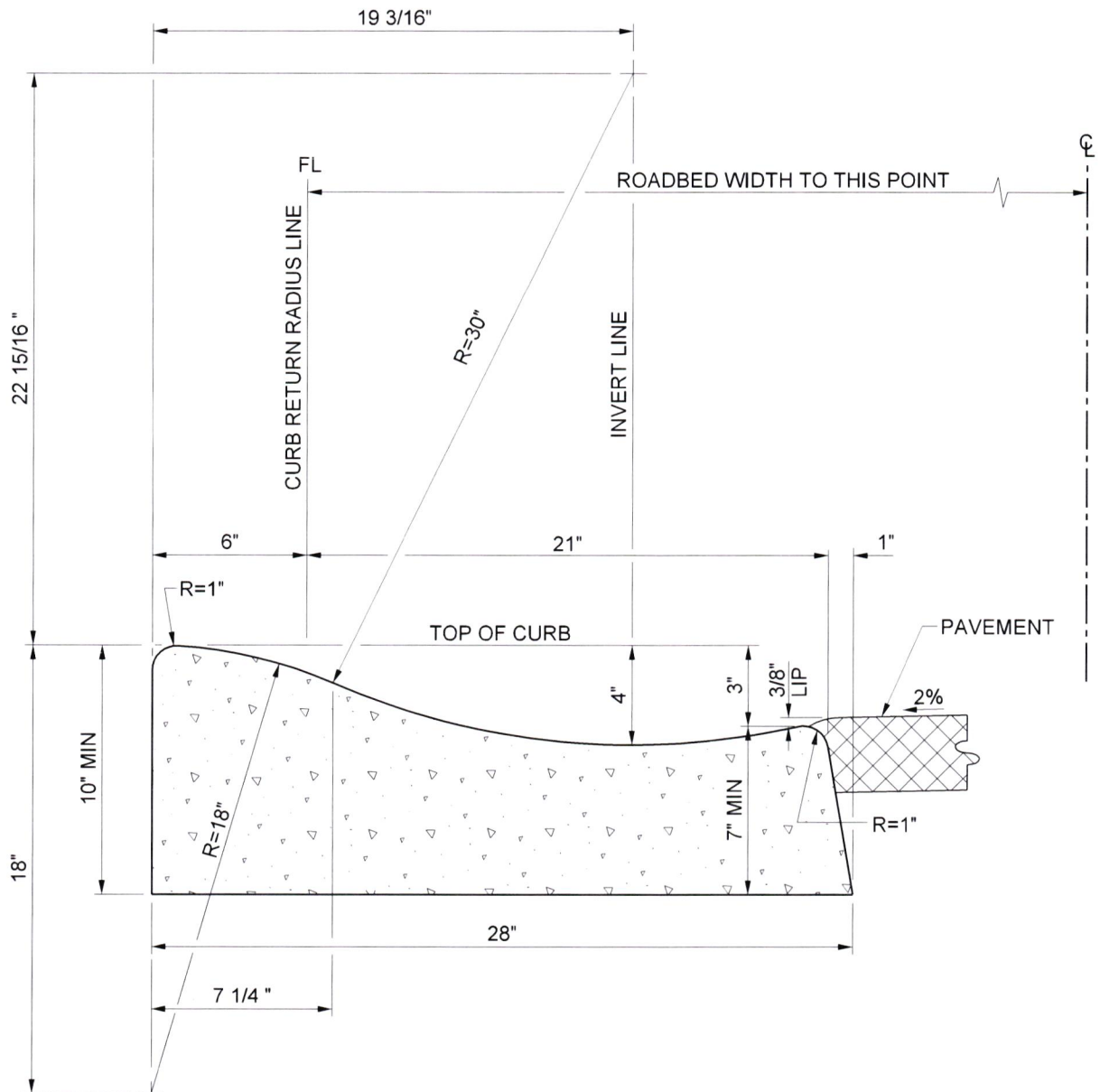

**MINIMUM CEMENTITIOUS MATERIAL CONTENT = 505 LB / CU YD**

1.418 CU FT / LF

1 CU YD = 19.05 LF

**NOTES:**

1. RELATIVE COMPACTION OF SUBGRADE UNDER CURB AND GUTTER SHALL BE 95% MINIMUM.
2. WHEN ABUTTING SOIL HAS A HIGH SULFATE CONTENT, USE A MODIFIED CONCRETE MIX AND PLACE 6" MIN CLASS 2 AGGREGATE BASE AND 6 MIL PLASTIC SHEETING UNDER AND AROUND ALL SIDES OF CONCRETE IMPROVEMENTS. FOR EXPANSIVE SOIL, PLACE 6" MIN CLASS 2 AGGREGATE BASE UNDER CONCRETE IMPROVEMENTS AS DIRECTED BY THE ENGINEER. SEE SPECIFICATIONS SECTIONS 16.03 & 16.04 AND STANDARD No. 401 FOR REFERENCE.

NOT TO SCALE

PREPARED UNDER THE SUPERVISION OF:

*Mark Lancaster*

11/30/22

DIRECTOR OF TRANSPORTATION  
MARK LANCASTER, P.E.

DATE



COUNTY OF RIVERSIDE

**TYPE "C" CURB  
ROLLED CURB**

**STANDARD No. 202**

REVISION	DESCRIPTION	MARK	DATE	APPROVED

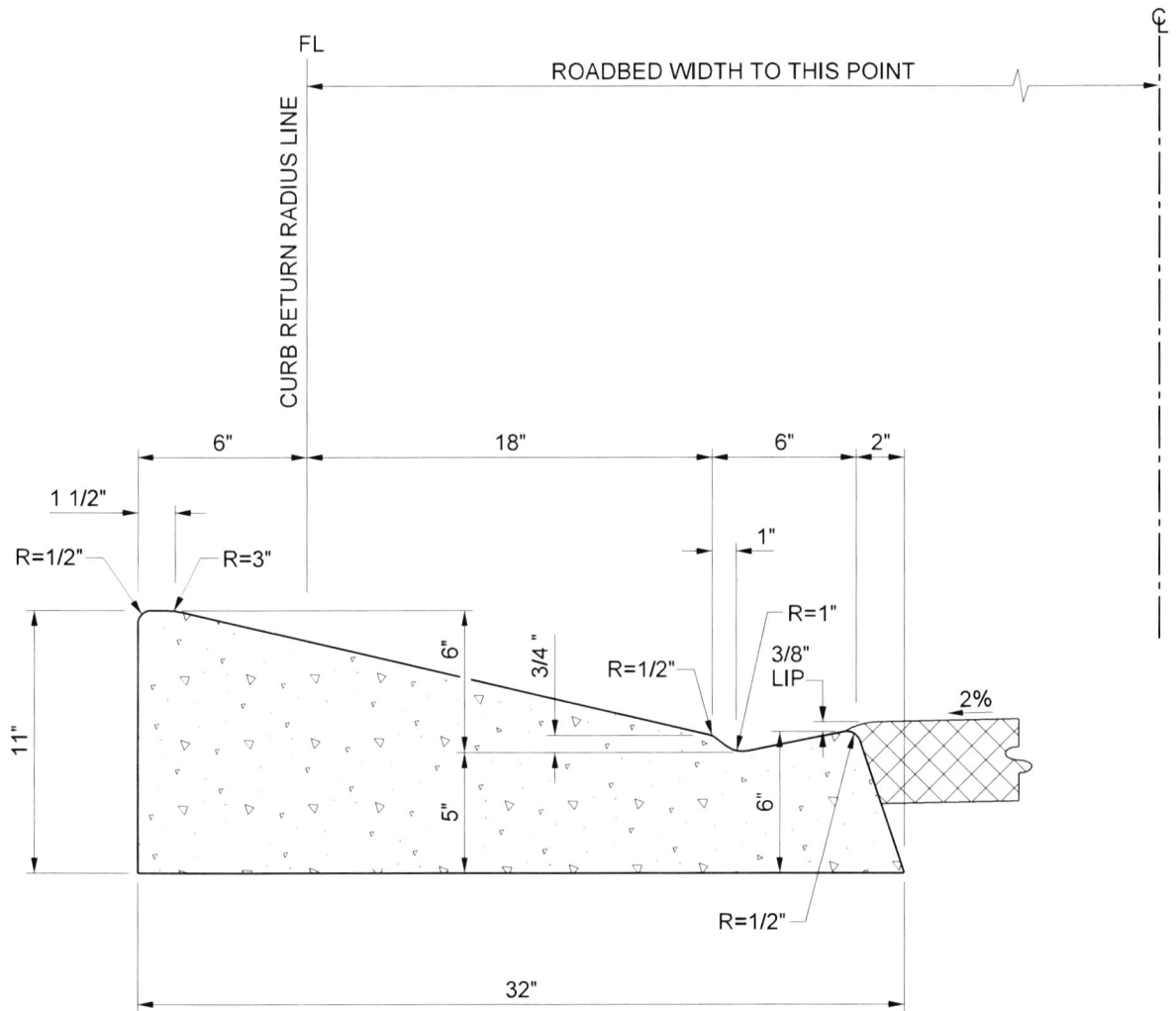

**MINIMUM CEMENTITIOUS MATERIAL CONTENT = 505 LB / CU YD**

1.666 CU FT / LF  
 1 CU YD = 16.21 LF

**NOTES:**

1. RELATIVE COMPACTION OF SUBGRADE UNDER CURB AND GUTTER SHALL BE 95% MINIMUM.
2. WHEN ABUTTING SOIL HAS A HIGH SULFATE CONTENT, USE A MODIFIED CONCRETE MIX AND PLACE 6" MIN CLASS 2 AGGREGATE BASE AND 6 MIL PLASTIC SHEETING UNDER AND AROUND ALL SIDES OF CONCRETE IMPROVEMENTS. FOR EXPANSIVE SOIL, PLACE 6" MIN CLASS 2 AGGREGATE BASE UNDER CONCRETE IMPROVEMENTS AS DIRECTED BY THE ENGINEER. SEE SPECIFICATIONS SECTIONS 16.03 & 16.04 AND STANDARD No. 401 FOR REFERENCE.

NOT TO SCALE

PREPARED UNDER THE SUPERVISION OF:

*Mark Lancaster* 11/30/22  
 DIRECTOR OF TRANSPORTATION DATE  
 MARK LANCASTER, P.E.

REVISION	DESCRIPTION	MARK	DATE	APPROVED

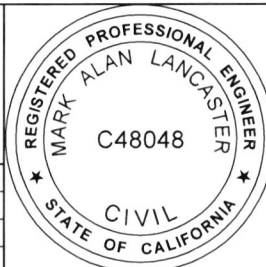

COUNTY OF RIVERSIDE

**TYPE "W" CURB  
 WEDGE CURB**

**STANDARD No. 202A**

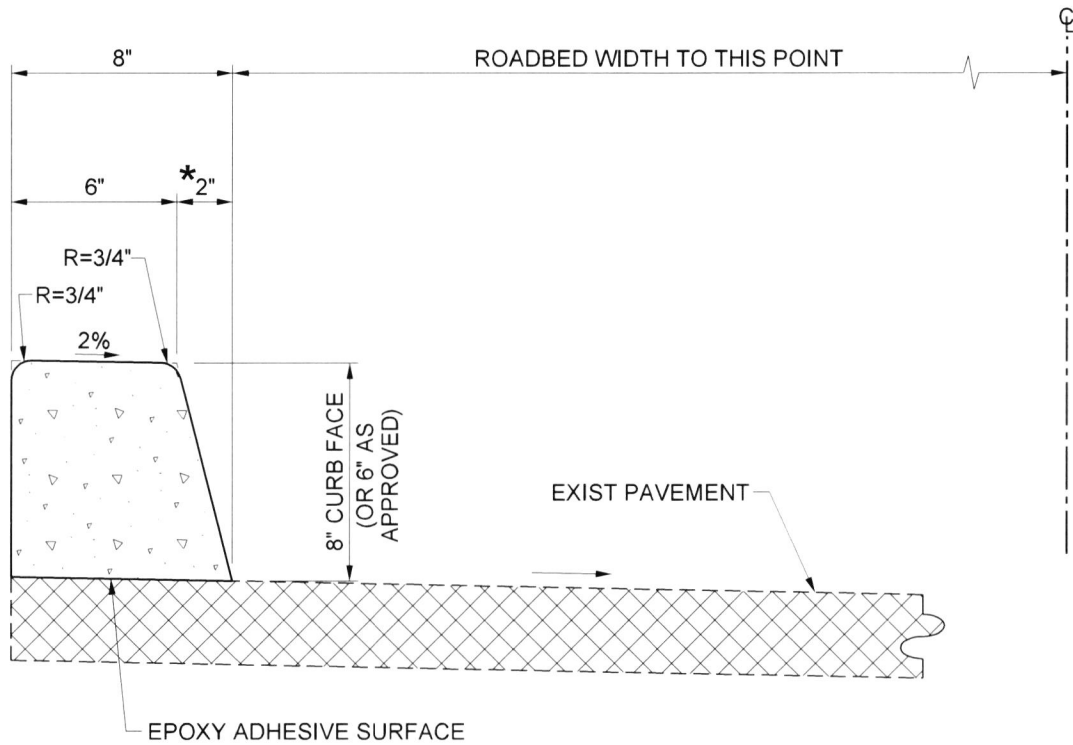

\* 1 1/2" FOR 6" CURB FACE

**MINIMUM CEMENTITIOUS MATERIAL CONTENT = 505 LB / CU YD**

0.391 CU FT / LF  
 1 CU YD = 69.05 LF

NOT TO SCALE

PREPARED UNDER THE SUPERVISION OF:

*Mark Lancaster*  
 DIRECTOR OF TRANSPORTATION  
 MARK LANCASTER, P.E.

11/30/22  
 DATE



COUNTY OF RIVERSIDE

**TYPE "D-1" CURB  
 ONLY ON  
 EXISTING PAVEMENT**

**STANDARD No. 203**

REVISION	DESCRIPTION	MARK	DATE	APPROVED

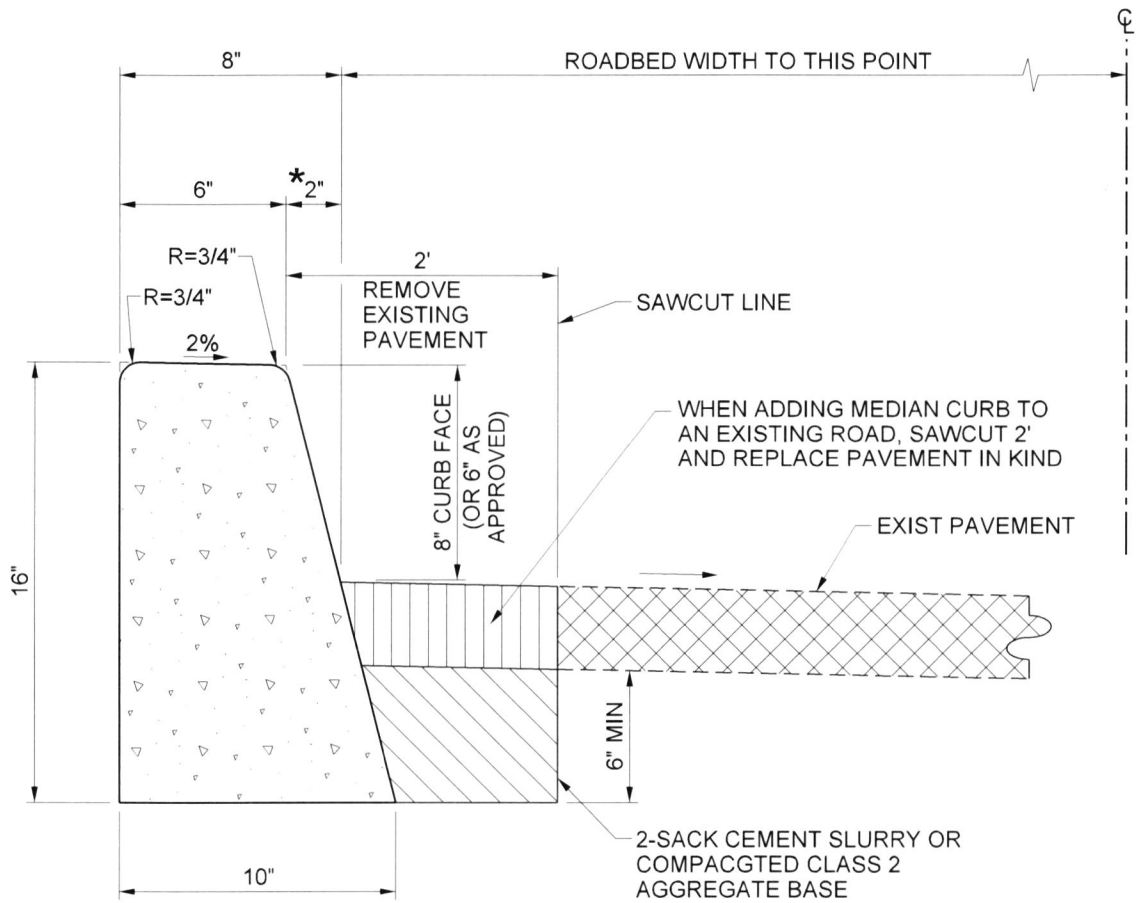

\* 1 1/2" FOR 6" CURB FACE

**MINIMUM CEMENTITIOUS MATERIAL CONTENT = 505 LB / CU YD**

0.888 CU FT / LF  
1 CU YD = 30.41 LF

**NOTES:**

1. RELATIVE COMPACTION OF SUBGRADE UNDER CURB AND GUTTER AND NEW PAVEMENT SHALL BE 95% MINIMUM.
2. WHEN ABUTTING SOIL HAS A HIGH SULFATE CONTENT, USE A MODIFIED CONCRETE MIX AND PLACE 6" MIN CLASS 2 AGGREGATE BASE AND 6 MIL PLASTIC SHEETING UNDER AND AROUND ALL SIDES OF CONCRETE IMPROVEMENTS. FOR EXPANSIVE SOIL, PLACE 6" MIN CLASS 2 AGGREGATE BASE UNDER CONCRETE IMPROVEMENTS AS DIRECTED BY THE ENGINEER. SEE SPECIFICATIONS SECTIONS 16.03 & 16.04 AND STANDARD No. 401 FOR REFERENCE.

NOT TO SCALE

PREPARED UNDER THE SUPERVISION OF:

*Mark Lancaster* 11/30/22  
DIRECTOR OF TRANSPORTATION DATE  
MARK LANCASTER, P.E.

REVISION	DESCRIPTION	MARK	DATE	APPROVED

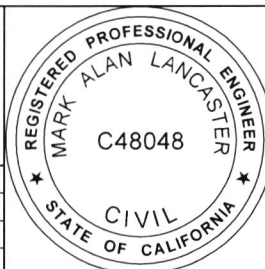

COUNTY OF RIVERSIDE

**TYPE "D" CURB ONLY**

**STANDARD No. 204**



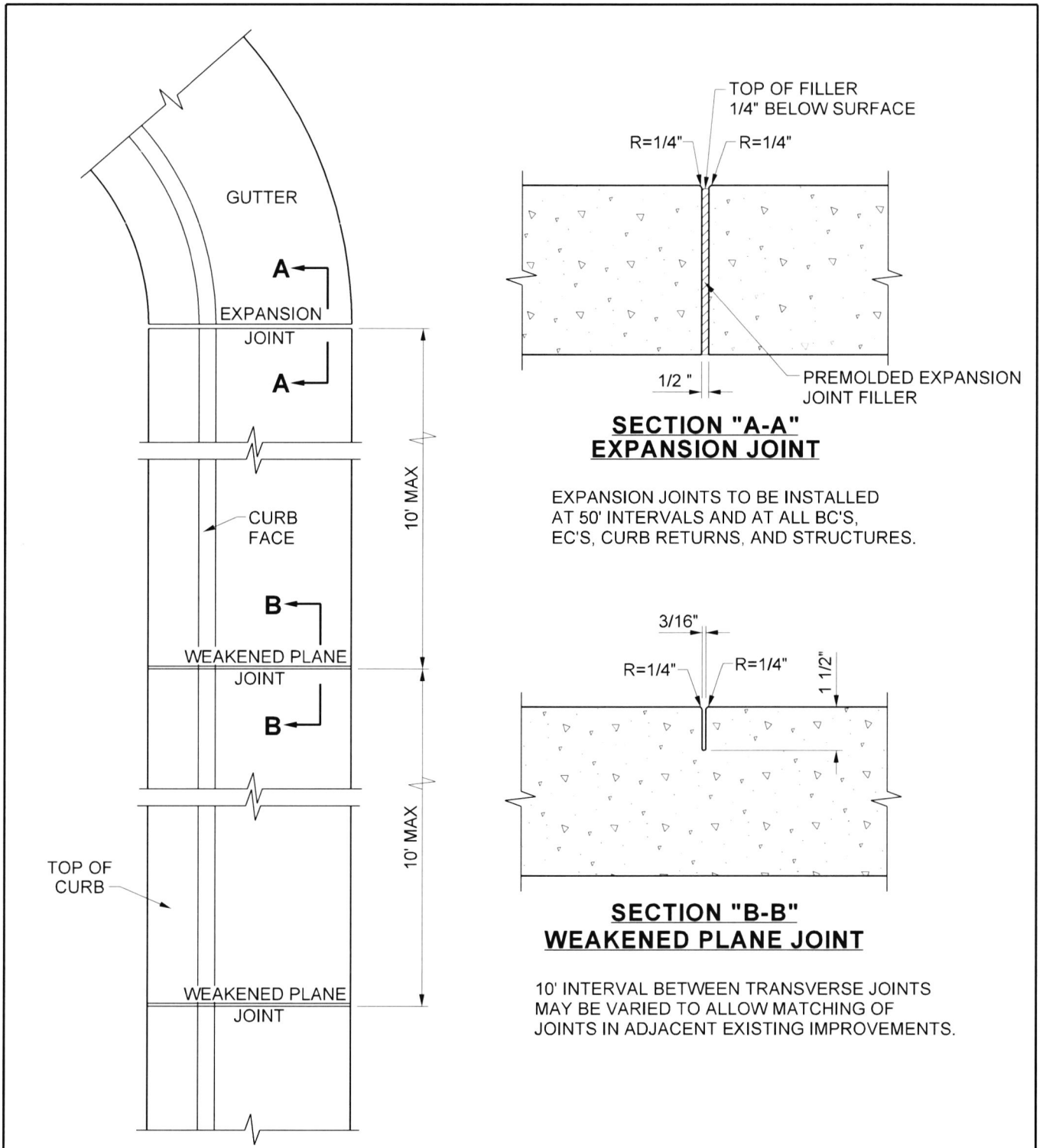

EXPANSION JOINTS TO BE INSTALLED AT 50' INTERVALS AND AT ALL BC'S, EC'S, CURB RETURNS, AND STRUCTURES.

10' INTERVAL BETWEEN TRANSVERSE JOINTS MAY BE VARIED TO ALLOW MATCHING OF JOINTS IN ADJACENT EXISTING IMPROVEMENTS.

NOT TO SCALE

PREPARED UNDER THE SUPERVISION OF:

*Mark Lancaster*

11/30/22  
DATE

DIRECTOR OF TRANSPORTATION  
MARK LANCASTER, P.E.



COUNTY OF RIVERSIDE

**CURB AND  
GUTTER JOINTS**

**STANDARD No. 205**

REVISION	DESCRIPTION	MARK	DATE	APPROVED

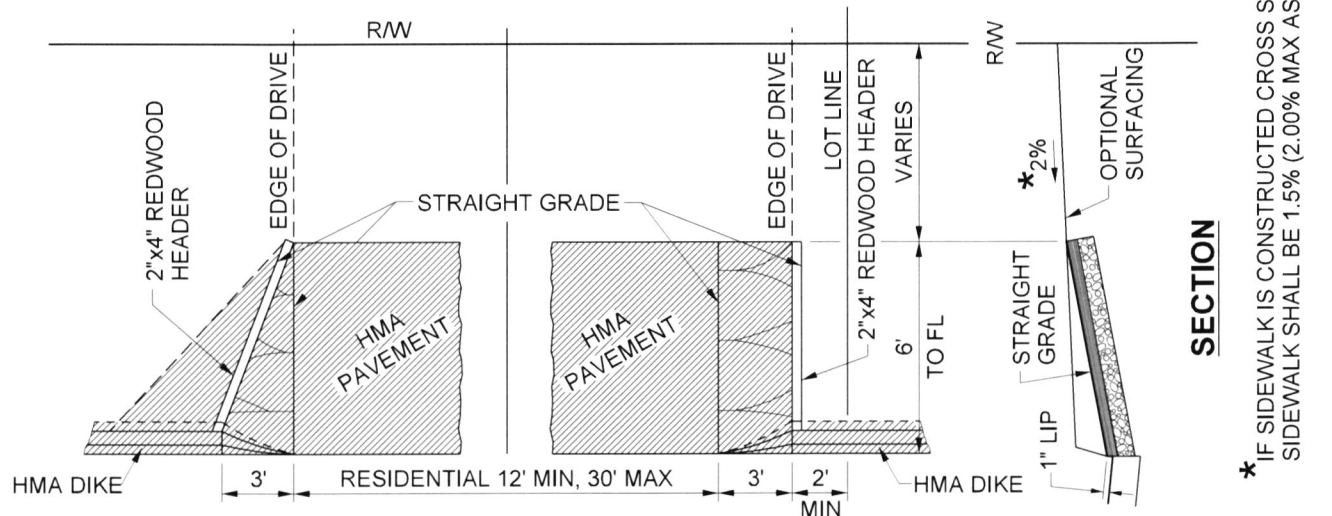
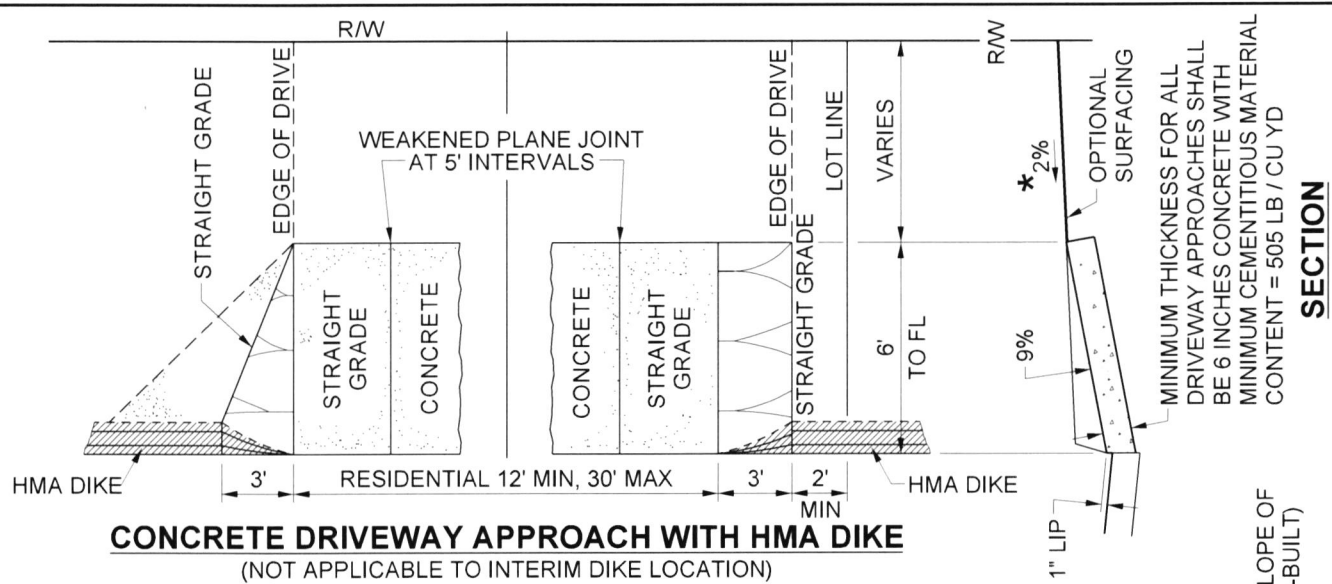

**NOTES:**

1. ALL CONSTRUCTION SHALL BE 2-1/2" MIN THICKNESS HOT MIX ASPHALT ON 4" MIN THICKNESS CLASS 2 OR CLASS 3 BASE, OR 3-1/2" THICKNESS HMA ON NATIVE SOIL.
2. 20' OF FULL HEIGHT DIKE REQUIRED BETWEEN DRIVEWAYS WITHIN ANY ONE PROPERTY UNLESS OTHERWISE PERMITTED.
3. RELATIVE COMPACTION OF SUBGRADE UNDER DRIVEWAYS SHALL BE 95% MINIMUM.
4. CONCRETE MINIMUM CEMENTITIOUS MATERIAL CONTENT = 505 LB / CU YD.

APRON TO BE CONSTRUCTED OF SAME MATERIAL AS DRIVEWAY WHEN STREET GRADIENT EXCEEDS 4%

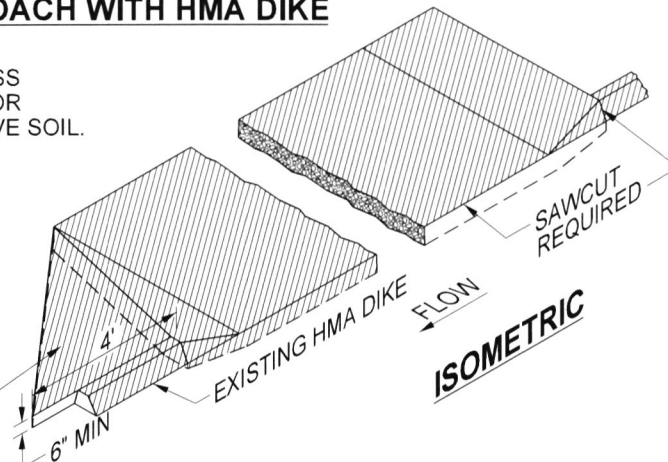

NOT TO SCALE

PREPARED UNDER THE SUPERVISION OF:

*Mark Lancaster*  
 DIRECTOR OF TRANSPORTATION  
 MARK LANCASTER, P.E.  
 11/30/22  
 DATE

REVISION	DESCRIPTION	MARK	DATE	APPROVED



COUNTY OF RIVERSIDE

**RESIDENTIAL  
DRIVEWAY  
WITH HMA DIKE**

STANDARD No. 206

**SECTION**

**SECTION**

\* IF SIDEWALK IS CONSTRUCTED CROSS SLOPE OF SIDEWALK SHALL BE 1.5% (2.00% MAX AS-BUILT)

MINIMUM THICKNESS FOR ALL DRIVEWAY APPROACHES SHALL BE 6 INCHES CONCRETE WITH MINIMUM CEMENTITIOUS MATERIAL CONTENT = 505 LB / CU YD

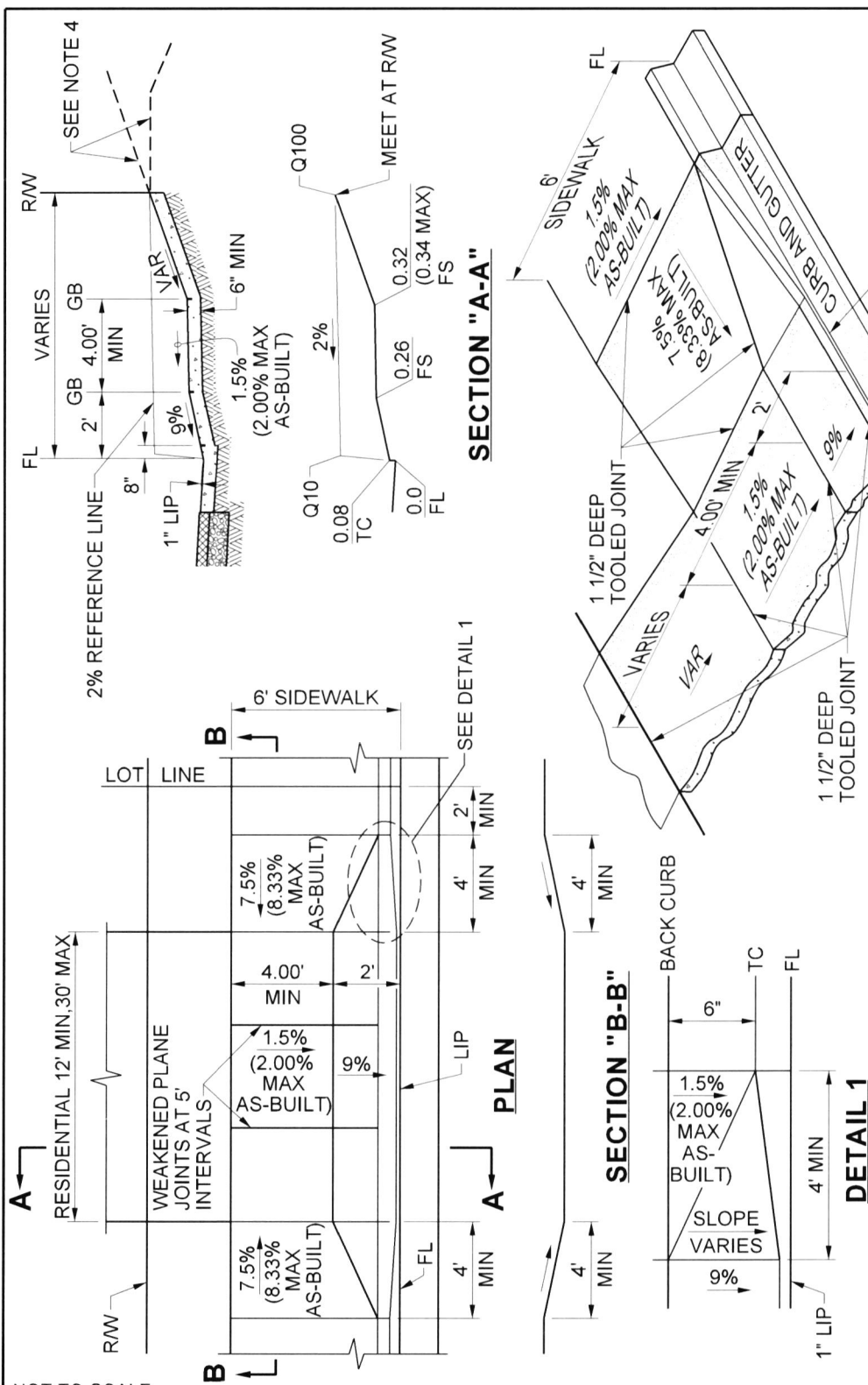

**ISOMETRIC**

- NOTES:**
1. CONCRETE MINIMUM CEMENTITIOUS MATERIAL CONTENT = 505 LB / CU YD.
  2. 20' OF FULL-HEIGHT CURB REQUIRED BETWEEN DRIVEWAYS WITHIN ANY ONE PROPERTY FRONTAGE.
  3. WHEN ABUTTING SOIL HAS A HIGH SULFATE CONTENT, USE A MODIFIED CONCRETE MIX AND PLACE 6" MIN CLASS 2 AGGREGATE BASE AND 6 MIL PLASTIC SHEETING UNDER AND AROUND ALL SIDES OF CONCRETE IMPROVEMENTS. FOR EXPANSIVE SOIL, PLACE 6" MIN CLASS 2 AGGREGATE BASE UNDER CONCRETE IMPROVEMENTS AS DIRECTED BY THE ENGINEER. SEE SPECIFICATIONS SECTIONS 16.03 & 16.04 AND STANDARD No. 401 FOR REFERENCE.
  4. CONSTRUCT THE PROFILE GRADE OF THE PRIVATE ON-SITE DRIVEWAY SO THAT IT PROVIDES SMOOTH VEHICLE ACCESS OVER THE DRIVE APPROACH.
  5. RELATIVE COMPACTION OF SUBGRADE UNDER DRIVEWAYS SHALL BE 95% MINIMUM.

SEE STANDARD No. 213  
FOR RESIDENTIAL DRIVEWAY  
WITH SIDEWALK AT RW

NOT TO SCALE

PREPARED UNDER THE SUPERVISION OF:

*Mark Lancaster* 11/30/22  
DIRECTOR OF TRANSPORTATION DATE  
MARK LANCASTER, P.E.

REVISION	DESCRIPTION	MARK	DATE	APPROVED



COUNTY OF RIVERSIDE

**RESIDENTIAL  
DRIVE APPROACH  
WITH SIDEWALK AT CURB**

**STANDARD No. 207**

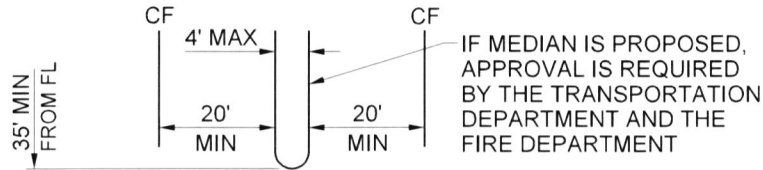

**MEDIAN DETAIL**

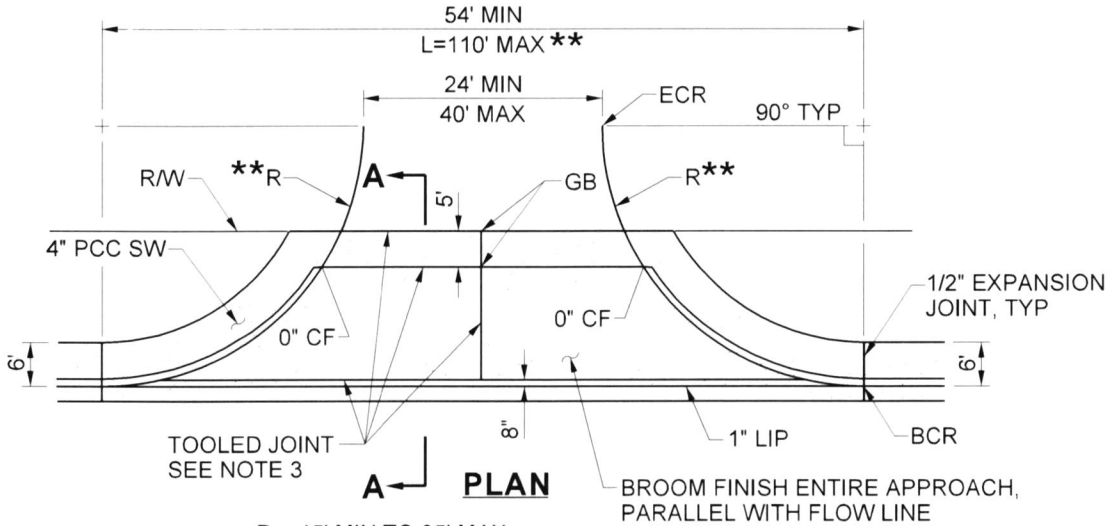

R = 15' MIN TO 35' MAX  
 \*\* SERVICE ENTRANCES ONLY: L=140' MAX, R=50' MAX

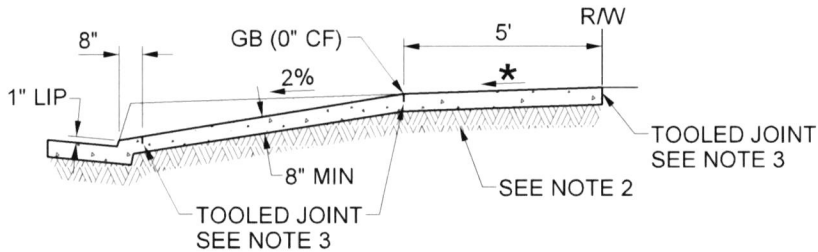

**SECTION "A-A"**

\* CROSS SLOPE OF SIDEWALK SHALL BE 1.5% (2.00% MAX AS-BUILT)

**NOTES:**

1. DRIVEWAY APPROACH SHALL BE 8" CONCRETE WITH MINIMUM CEMENTITIOUS MATERIAL CONTENT = 590 LB / CU YD.
2. RELATIVE COMPACTION OF SUBGRADE UNDER DRIVEWAY APPROACH SHALL BE 95% MIN.
3. APPROACHES SHALL HAVE 1 1/2" DEEP 3/16" WIDE TOOLED JOINT AT CENTER OF APPROACH AND AS SHOWN HEREON. ALL OTHER SCORE LINES SHALL BE 10'-0" MAX OC.
4. WHEN ABUTTING SOIL HAS A HIGH SULFATE CONTENT, USE A MODIFIED CONCRETE MIX AND PLACE 6" MIN CLASS 2 AGGREGATE BASE AND 6 MIL PLASTIC SHEETING UNDER AND AROUND ALL SIDES OF CONCRETE IMPROVEMENTS. FOR EXPANSIVE SOIL, PLACE 6" MIN CLASS 2 AGGREGATE BASE UNDER CONCRETE IMPROVEMENTS AS DIRECTED BY THE ENGINEER. SEE SPECIFICATIONS SECTIONS 16.03 & 16.04 AND STANDARD No. 401 FOR REFERENCE.

NOT TO SCALE

PREPARED UNDER THE SUPERVISION OF:

*Mark Lancaster* 11/30/22  
 DIRECTOR OF TRANSPORTATION DATE  
 MARK LANCASTER, P.E.

REVISION	DESCRIPTION	MARK	DATE	APPROVED



COUNTY OF RIVERSIDE

**COMMERCIAL  
 DRIVE APPROACH  
 (WITH SIDEWALK AT CURB)**

**STANDARD No. 207A (1 OF 4)**

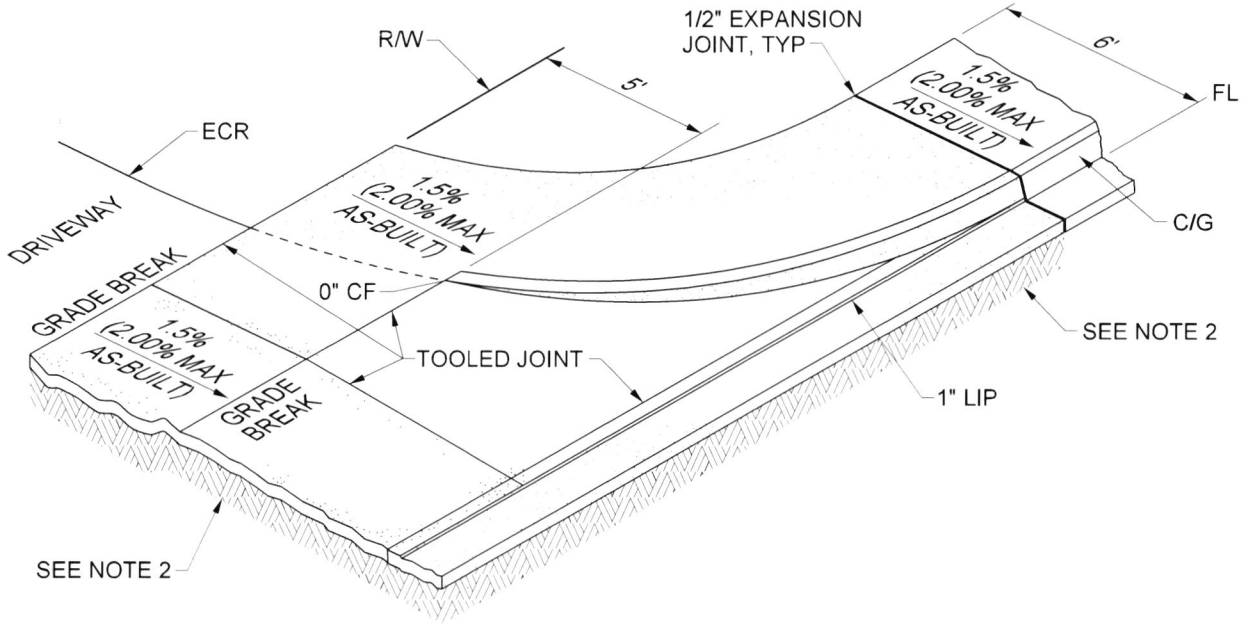

**ISOMETRIC VIEW**

NOT TO SCALE

FOR NOTES SEE SHEET 1

PREPARED UNDER THE SUPERVISION OF:

*Mark Lancaster*

11/30/22  
DATE

DIRECTOR OF TRANSPORTATION  
MARK LANCASTER, P.E.



COUNTY OF RIVERSIDE

**COMMERCIAL  
DRIVE APPROACH  
(WITH SIDEWALK AT CURB)**

STANDARD No. 207A (2 OF 4)

REVISION DESCRIPTION	MARK	DATE	APPROVED

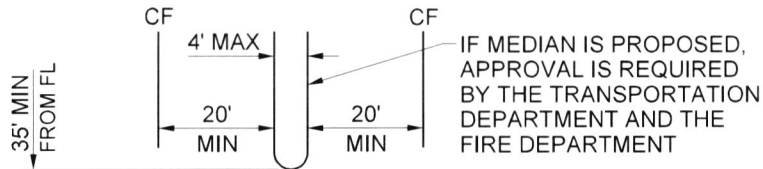

**MEDIAN DETAIL**

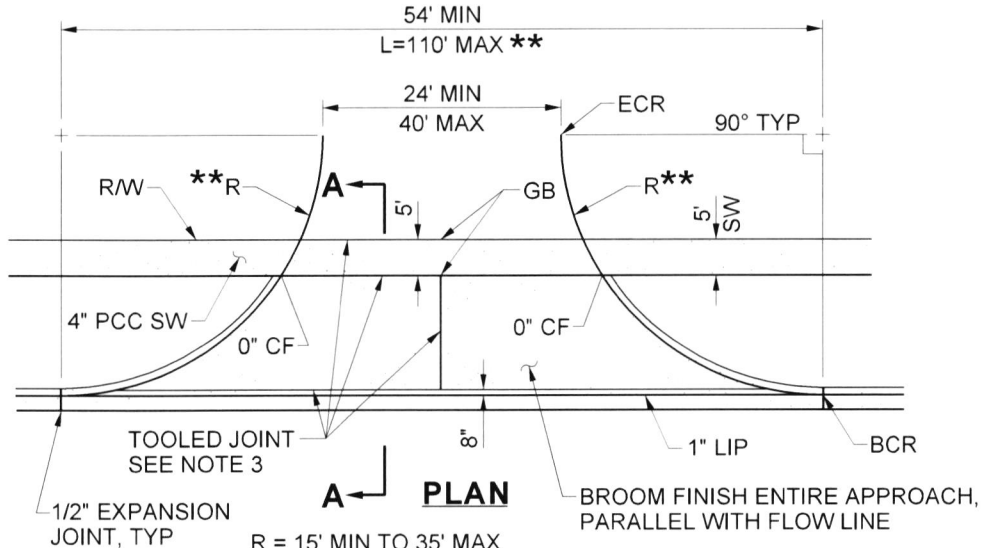

R = 15' MIN TO 35' MAX  
 \*\* SERVICE ENTRANCES ONLY: L=140' MAX, R=50' MAX

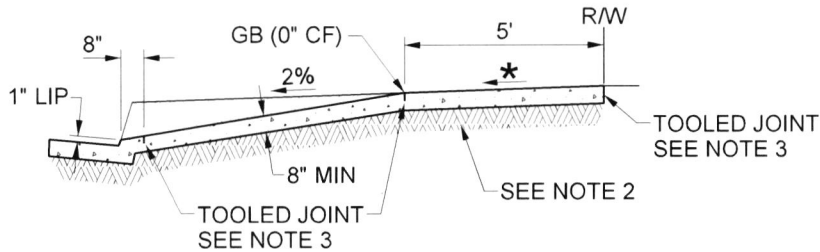

**SECTION "A-A"**

\* CROSS SLOPE OF SIDEWALK SHALL BE 1.5% (2.00% MAX AS-BUILT)

**NOTES:**

1. DRIVEWAY APPROACH SHALL BE 8" CONCRETE WITH MINIMUM CEMENTITIOUS MATERIAL CONTENT = 590 LB / CU YD.
2. RELATIVE COMPACTION OF SUBGRADE UNDER DRIVEWAY APPROACH SHALL BE 95% MIN.
3. APPROACHES SHALL HAVE 1 1/2" DEEP 3/16" WIDE TOOLED JOINT AT CENTER OF APPROACH AND AS SHOWN HEREON. ALL OTHER SCORE LINES SHALL BE 10'-0" MAX OC.
4. WHEN ABUTTING SOIL HAS A HIGH SULFATE CONTENT, USE A MODIFIED CONCRETE MIX AND PLACE 6" MIN CLASS 2 AGGREGATE BASE AND 6 MIL PLASTIC SHEETING UNDER AND AROUND ALL SIDES OF CONCRETE IMPROVEMENTS. FOR EXPANSIVE SOIL, PLACE 6" MIN CLASS 2 AGGREGATE BASE UNDER CONCRETE IMPROVEMENTS AS DIRECTED BY THE ENGINEER. SEE SPECIFICATIONS SECTIONS 16.03 & 16.04 AND STANDARD No. 401 FOR REFERENCE.

NOT TO SCALE

PREPARED UNDER THE SUPERVISION OF:

*Mark Lancaster*  
 DIRECTOR OF TRANSPORTATION  
 MARK LANCASTER, P.E.  
 11/30/22  
 DATE

REVISION	DESCRIPTION	MARK	DATE	APPROVED



COUNTY OF RIVERSIDE

**COMMERCIAL  
 DRIVE APPROACH  
 (WITH SIDEWALK AT R/W)**

**STANDARD No. 207A (3 OF 4)**

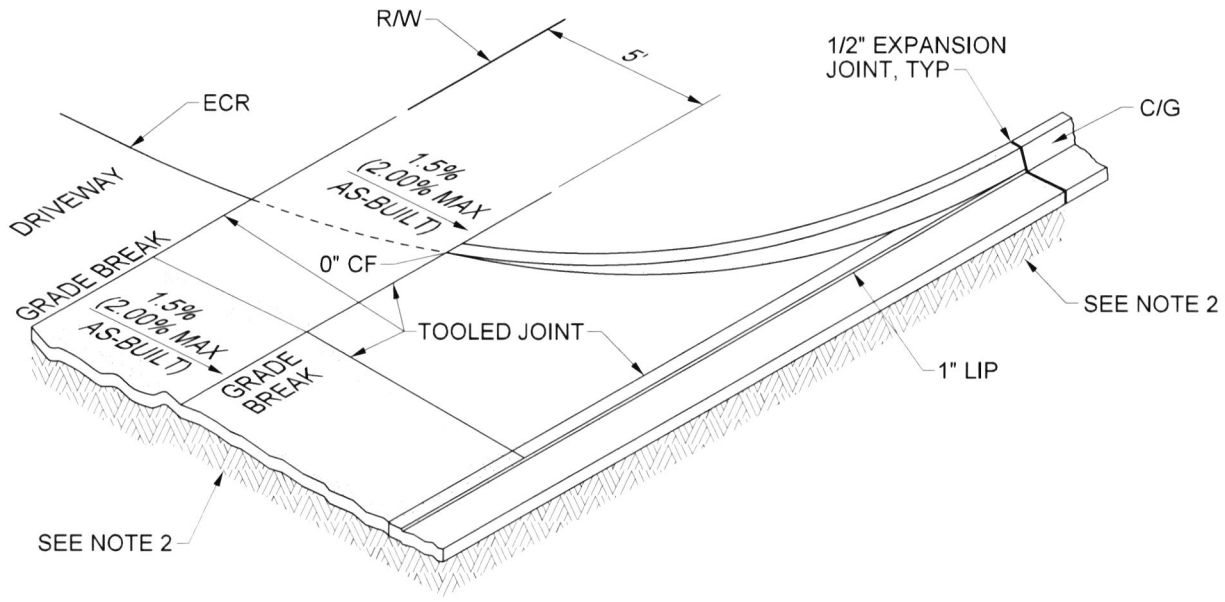

**ISOMETRIC VIEW**

NOT TO SCALE FOR NOTES SEE SHEET 3

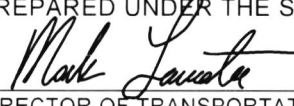
PREPARED UNDER THE SUPERVISION OF:  
  
 11/30/22  
 DIRECTOR OF TRANSPORTATION DATE  
 MARK LANCASTER, P.E.



COUNTY OF RIVERSIDE

**COMMERCIAL DRIVE APPROACH (WITH SIDEWALK AT R/W)**

STANDARD No. 207A (4 OF 4)

REVISION	DESCRIPTION	MARK	DATE	APPROVED

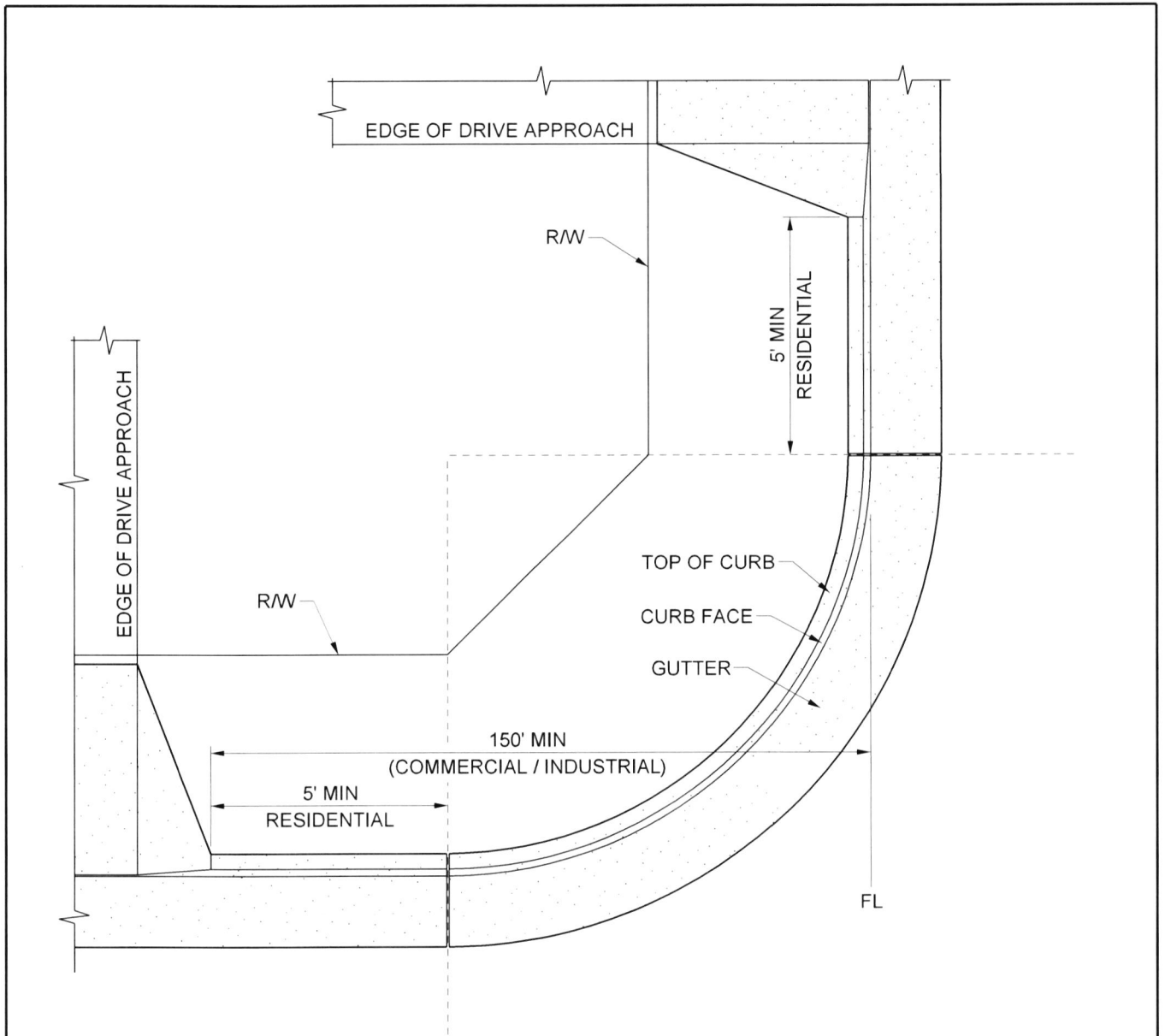

**RESIDENTIAL ONLY:**

NO PORTION OF ANY DRIVE APPROACH SHALL BE PERMITTED WITHIN 5' OF THE POINTS OF CURVATURE.

**COMMERCIAL / INDUSTRIAL:**

NO PORTION OF ANY DRIVE APPROACH SHALL BE PERMITTED WITHIN 150' OF THE FLOWLINE OF AN INTERSECTING STREET OR AS APPROVED BY THE DIRECTOR OF TRANSPORTATION.

NOT TO SCALE

PREPARED UNDER THE SUPERVISION OF:

*Mark Lancaster* 11/30/22  
 DIRECTOR OF TRANSPORTATION DATE  
 MARK LANCASTER, P.E.

REVISION	DESCRIPTION	MARK	DATE	APPROVED



COUNTY OF RIVERSIDE

**DRIVE APPROACH LOCATIONS  
 AT INTERSECTION  
 CURB RETURNS**

**STANDARD No. 208**



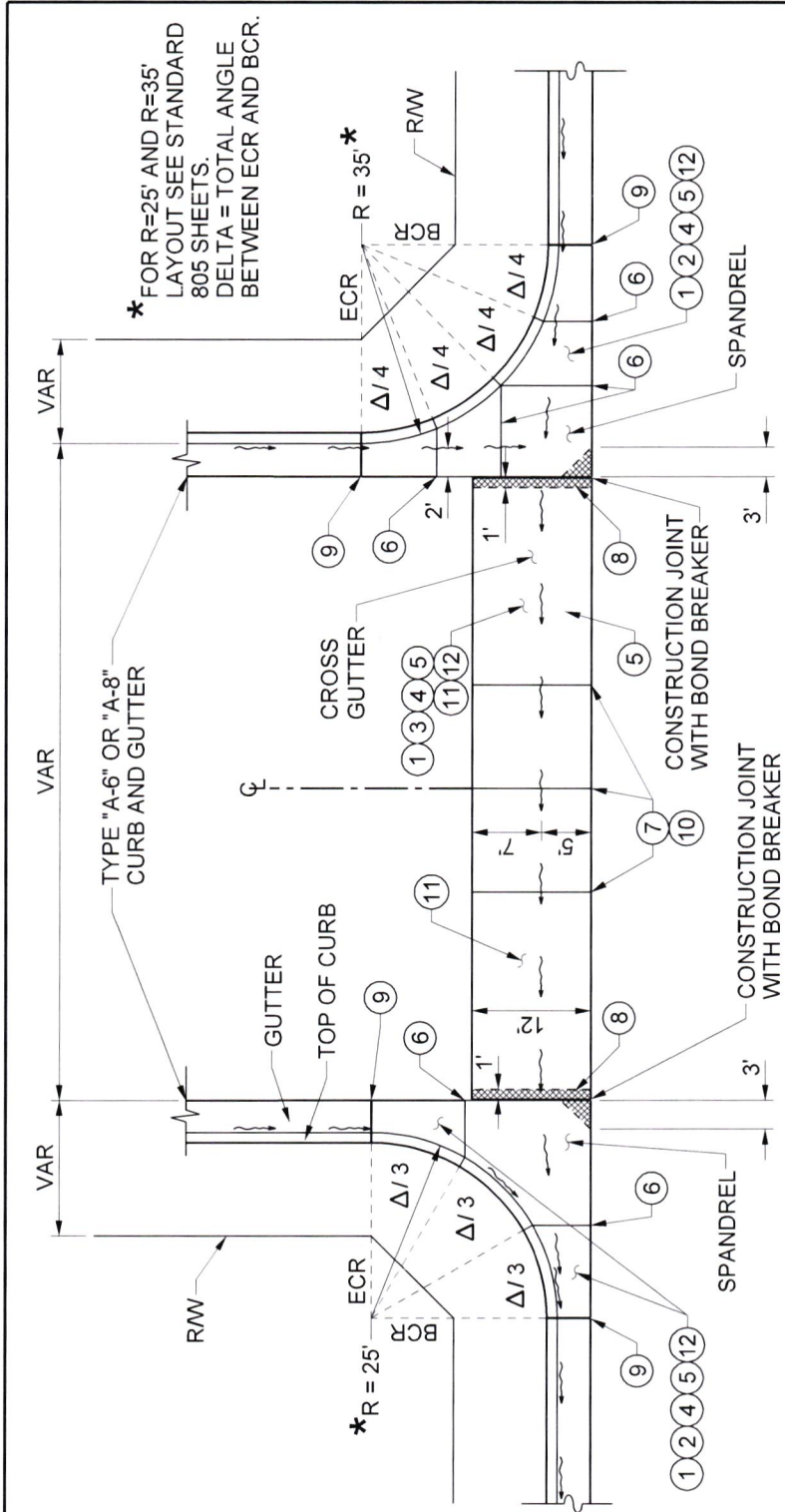

\* FOR R=25' AND R=35' LAYOUT SEE STANDARD 805 SHEETS. DELTA = TOTAL ANGLE BETWEEN ECR AND BCR.

TYPE "A-6" OR "A-8" CURB AND GUTTER

TYPE "A-6" OR "A-8" CURB AND GUTTER

NOT TO SCALE

PREPARED UNDER THE SUPERVISION OF:

*Mark Lancaster*  
 DIRECTOR OF TRANSPORTATION  
 MARK LANCASTER, P.E.

11/30/22  
 DATE

REVISION	DESCRIPTION	MARK	DATE	APPROVED



COUNTY OF RIVERSIDE

**CROSS GUTTER AND SPANDREL (LAYOUT)**

STANDARD No. 209 (1 OF 2)

**NOTES:**

- 1 CROSS GUTTER AND SPANDREL FOR USE WITH TYPES "A-6" AND "A-8" CURB.
- 2 SPANDREL THICKNESS TO BE 8" MINIMUM.
- 3 CROSS GUTTER THICKNESS TO BE 8" MINIMUM.
- 4 CONCRETE MINIMUM CEMENTITIOUS MATERIAL CONTENT = 590 LB / CU YD.
- 5 PLACE MIN 6" AB UNDER ENTIRE SPANDREL AND CROSS GUTTER AREA.
- 6 WEAKENED PLANE JOINTS TO BE CONSTRUCTED AT 1/3 POINTS ON 25' RADIUS SPANDRELS, AND AT 1/4 POINTS ON 35' RADIUS SPANDRELS.
- 7 CONSTRUCT WEAKENED PLANE JOINT(S) PER STANDARD No. 205 AT MIDPOINT OF CROSS GUTTERS LESS THAN 40' LONG, OR AT 1/3 POINTS OF CROSS GUTTERS OF 40' OR LONGER.
- 8 THIS PORTION OF SPANDREL AND CROSS GUTTER SHALL BE CONSTRUCTED WITH 12 INCH THICK, CONCRETE WITH MINIMUM CEMENTITIOUS MATERIAL CONTENT = 590 LB / CU YD.
- 9 CONSTRUCT EXPANSION JOINT PER STANDARD No. 205.
- 10 CONSTRUCT WEAKENED PLANE JOINT PER STANDARD No. 205.
- 11 CONSTRUCT CROSS GUTTER PER TYPICAL SECTION ON SHEET 2.
- 12 WHEN ABUTTING SOIL HAS A HIGH SULFATE CONTENT, SPECIAL CONSIDERATIONS ARE REQUIRED. SEE SPECIFICATIONS SECTION 16.04 OF THIS ORDINANCE.

**NOTE:**

FOR PUBLIC WORKS PROJECTS, THE SIDEWALK AND CURB FROM BCR TO ECR SHALL BE INCLUDED IN THE CONTRACT UNIT PRICE FOR "CURB RAMP".

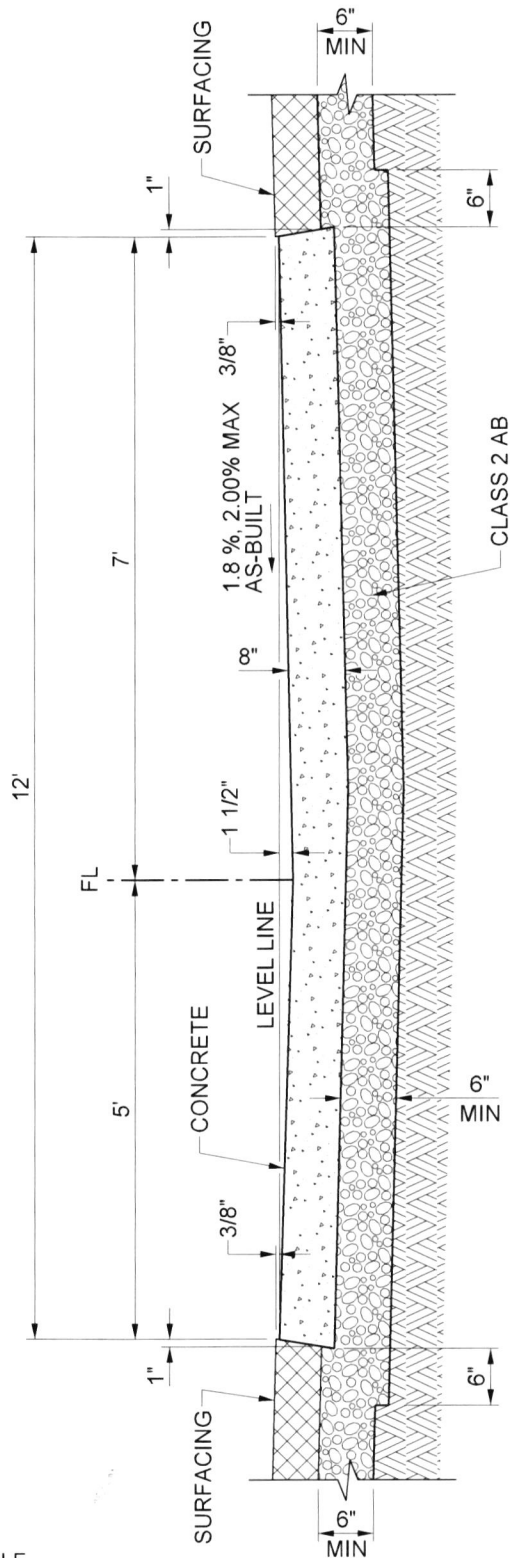

**CROSS GUTTER**

**NOTES:**

1. WHEN ABUTTING SOIL HAS A HIGH SULFATE CONTENT, USE A MODIFIED CONCRETE MIX AND PLACE 6" MIN CLASS 2 AGGREGATE BASE AND 6 MIL PLASTIC SHEETING UNDER AND AROUND ALL SIDES OF CONCRETE IMPROVEMENTS FOR EXPANSIVE SOIL, PLACE 6" MIN CLASS 2 AGGREGATE BASE UNDER CONCRETE IMPROVEMENTS AS DIRECTED BY THE ENGINEER. SEE SPECIFICATIONS SECTIONS 16.03 & 16.04 AND STANDARD No. 401 FOR REFERENCE.
2. RELATIVE COMPACTION OF SUBGRADE UNDER CROSS GUTTER AND SPANDREL SHALL BE 95% MINIMUM.
3. FOR PUBLIC WORKS PROJECTS, THE AB AND ALL REQUIRED MATERIAL SHALL BE INCLUDED IN THE CONTRACT UNIT PRICE.
4. CONCRETE FOR CROSS GUTTER AND SPANDREL SHALL HAVE MINIMUM CEMENTITIOUS MATERIAL CONTENT = 590 LB / CU YD.

NOT TO SCALE

PREPARED UNDER THE SUPERVISION OF:

*Mark Lancaster*  
 DIRECTOR OF TRANSPORTATION  
 MARK LANCASTER, P.E.

11/30/22  
 DATE

REVISION	DESCRIPTION	MARK	DATE	APPROVED



COUNTY OF RIVERSIDE

**CROSS GUTTER  
 AND SPANDREL  
 (TYPICAL SECTION)**

STANDARD No. 209 (2 OF 2)

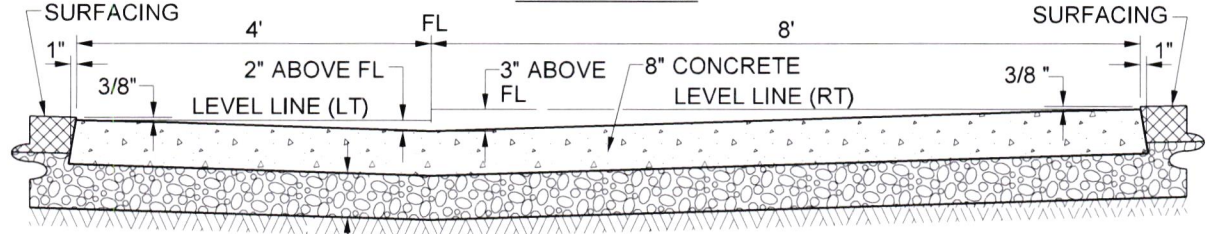
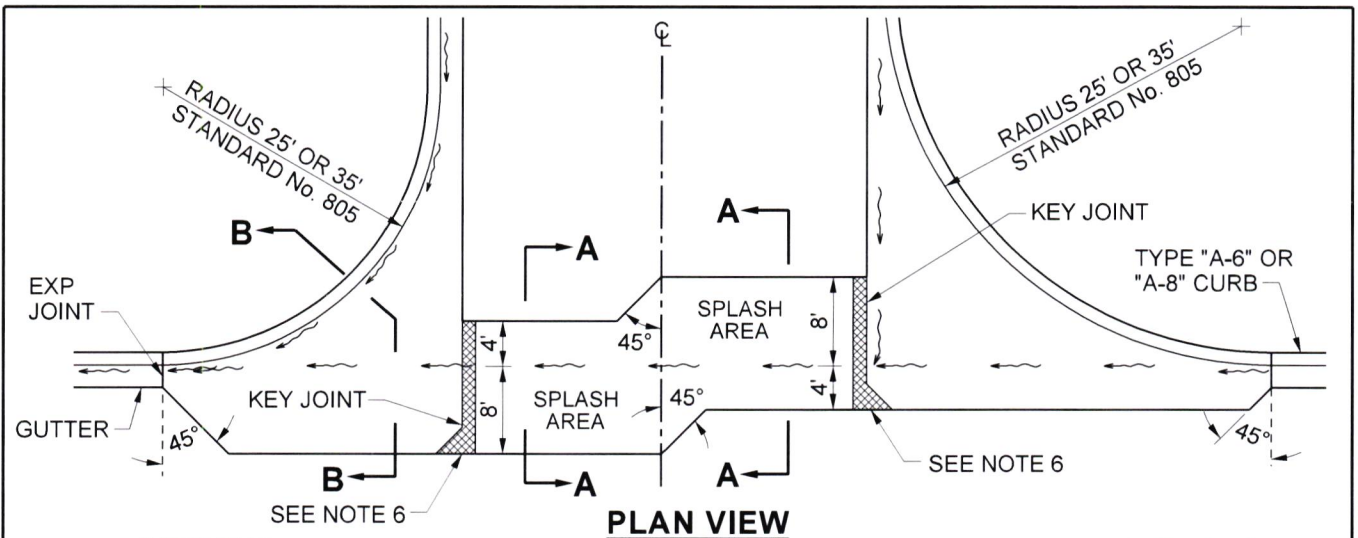

6" MIN GRAVEL OR BASE MATERIAL **CROSS GUTTER (SECTION "A-A")**

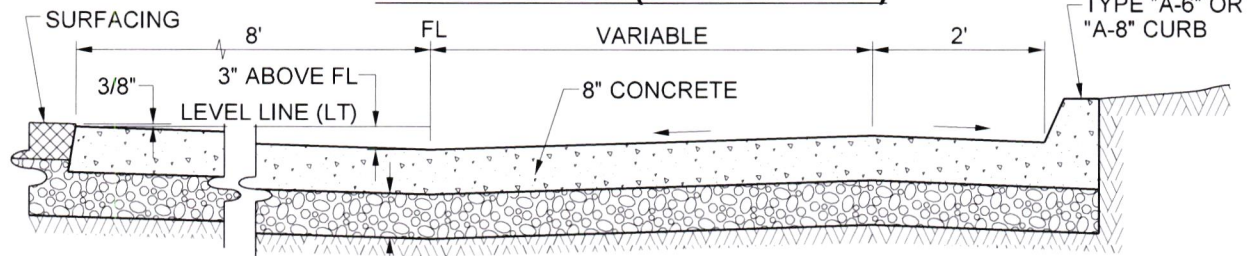

6" MIN GRAVEL OR BASE MATERIAL **SPANDREL (SECTION "B-B")**

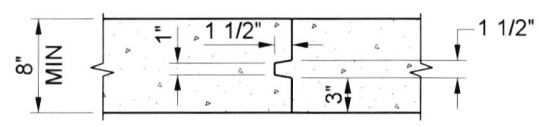

**KEY JOINT (SECTION)**

**NOTES:**

1. THIS CROSS GUTTER STANDARD TO BE CONSTRUCTED IN AREAS WHERE STREET GUTTERS HAVE CONSTANT OR FREQUENT FLOWS FROM LANDSCAPED PARKWAYS AND MEDIANS, GOLF COURSE, AND AGRICULTURAL RUNOFF OR WHEN GRADIENT IS LESS THAN 0.8%.
2. WHEN ABUTTING SOIL HAS A HIGH SULFATE CONTENT, USE A MODIFIED CONCRETE MIX AND PLACE 6" MIN CLASS 2 AGGREGATE BASE AND 6 MIL PLASTIC SHEETING UNDER AND AROUND ALL SIDES OF CONCRETE IMPROVEMENTS. FOR EXPANSIVE SOIL, PLACE 6" MIN CLASS 2 AGGREGATE BASE UNDER CONCRETE IMPROVEMENTS AS DIRECTED BY THE ENGINEER. SEE SPECIFICATIONS SECTIONS 16.03 & 16.04 AND STANDARD No. 401 FOR REFERENCE.
3. RELATIVE COMPACTION OF SUBGRADE UNDER ROADWAY, CURB AND CROSSOVER MEDIAN SHALL BE 95% MINIMUM.
4. CONCRETE MINIMUM CEMENTITIOUS MATERIAL CONTENT = 590 LB / CU YD.
5. SEE STANDARD No. 209 FOR ADDITIONAL NOTES.
6. THIS PORTION OF SPANDREL AND CROSS GUTTER SHALL BE CONSTRUCTED WITH 12 INCH THICK, CONCRETE WITH MIN CEMENTITIOUS MATERIAL CONTENT = 590 LB / CU YD.

NOT TO SCALE

PREPARED UNDER THE SUPERVISION OF:			
<i>Mark Lancaster</i>			11/30/22
DIRECTOR OF TRANSPORTATION MARK LANCASTER, P.E.			DATE
REVISION	DESCRIPTION	MARK	DATE



COUNTY OF RIVERSIDE

**CROSS GUTTER  
AND SPANDREL  
WITH SPLASH AREA**

**STANDARD No. 210**

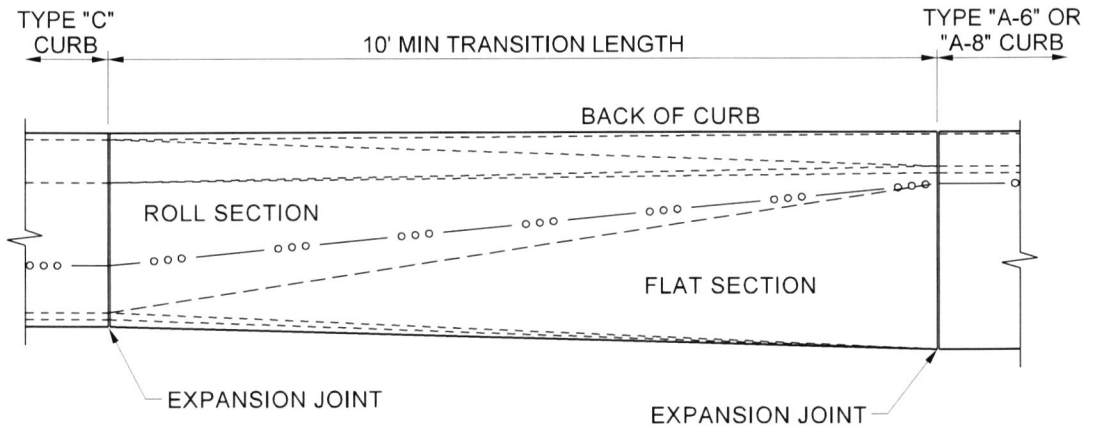

**PLAN VIEW**

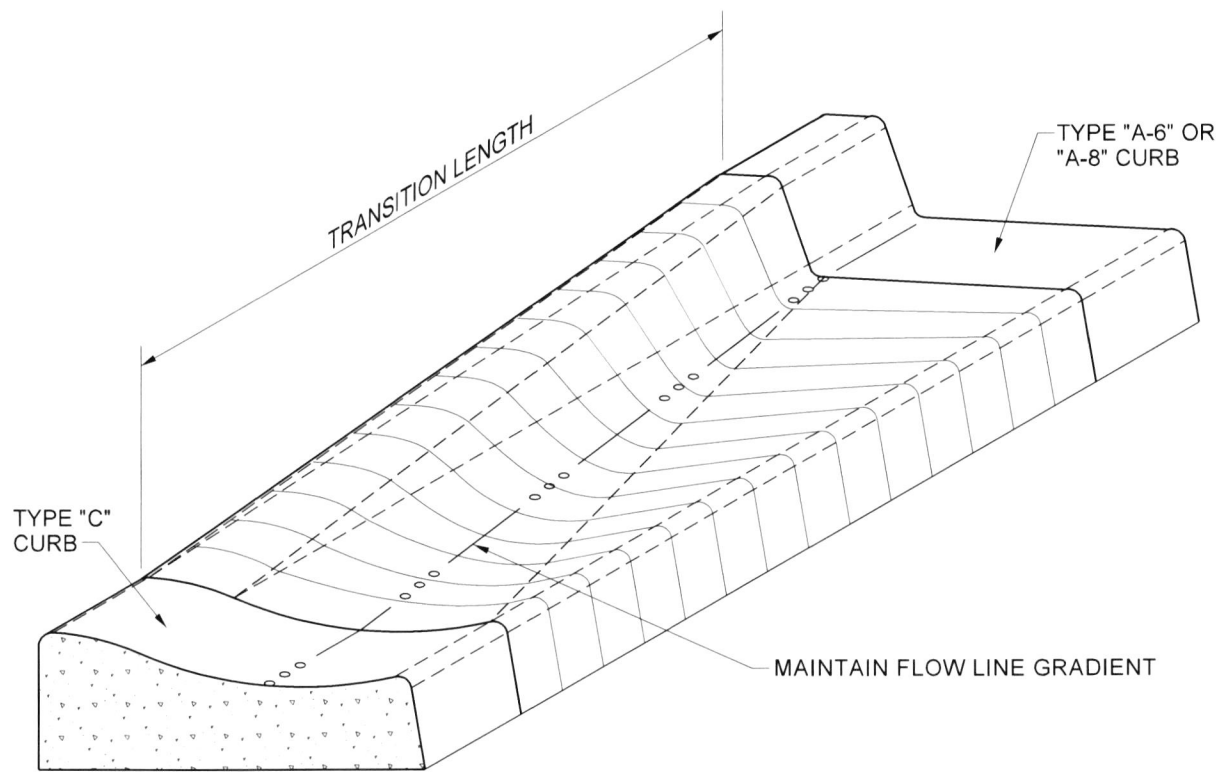

**ISOMETRIC VIEW**

MINIMUM CEMENTITIOUS MATERIAL  
CONTENT = 505 LB / CU YD.

NOT TO SCALE

PREPARED UNDER THE SUPERVISION OF:

*Mark Lancaster*

11/30/22  
DATE

DIRECTOR OF TRANSPORTATION  
MARK LANCASTER, P.E.



COUNTY OF RIVERSIDE

**CURB TRANSITION**

**STANDARD No. 211**

REVISION DESCRIPTION	MARK	DATE	APPROVED

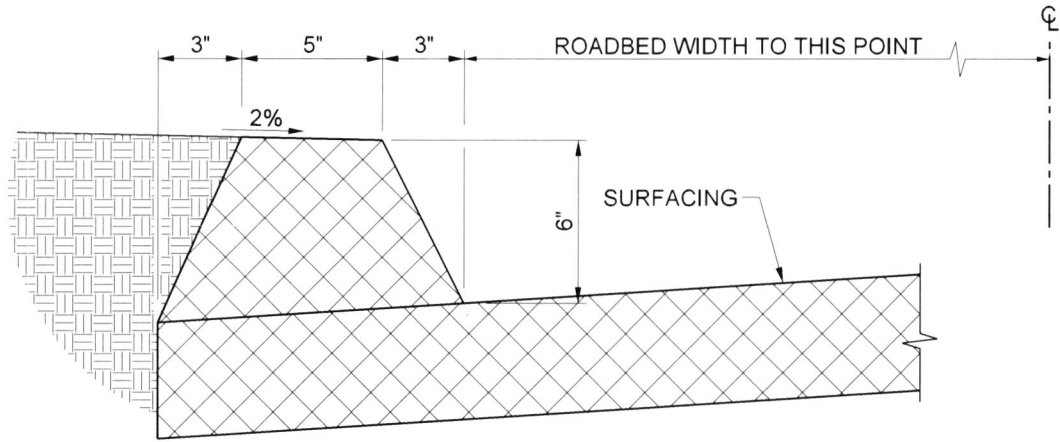

**6" HMA DIKE**

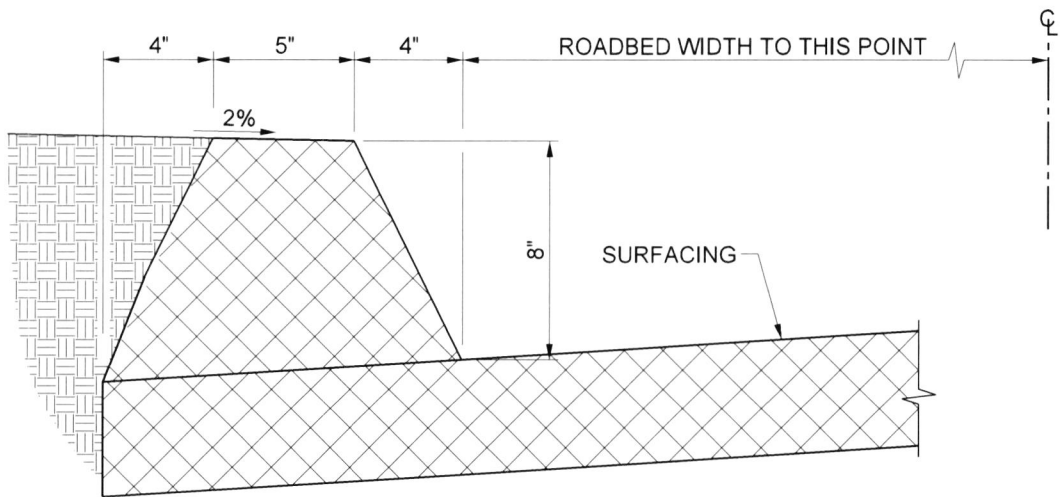

**8" HMA DIKE**

**NOTE:**

1. HMA DIKE REQUIRED WHERE FILL SLOPES ARE STEEPER THAN 4:1, MATERIAL IS SUSCEPTIBLE TO EROSION, OR WHERE ROADWAY GRADIENT EXCEEDS 3%.

NOT TO SCALE

PREPARED UNDER THE SUPERVISION OF:

*Mark Lancaster*  
 DIRECTOR OF TRANSPORTATION  
 MARK LANCASTER, P.E.  
 11/30/22  
 DATE



COUNTY OF RIVERSIDE

**HOT MIX  
 ASPHALT DIKES**

**STANDARD No. 212**

REVISION	DESCRIPTION	MARK	DATE	APPROVED

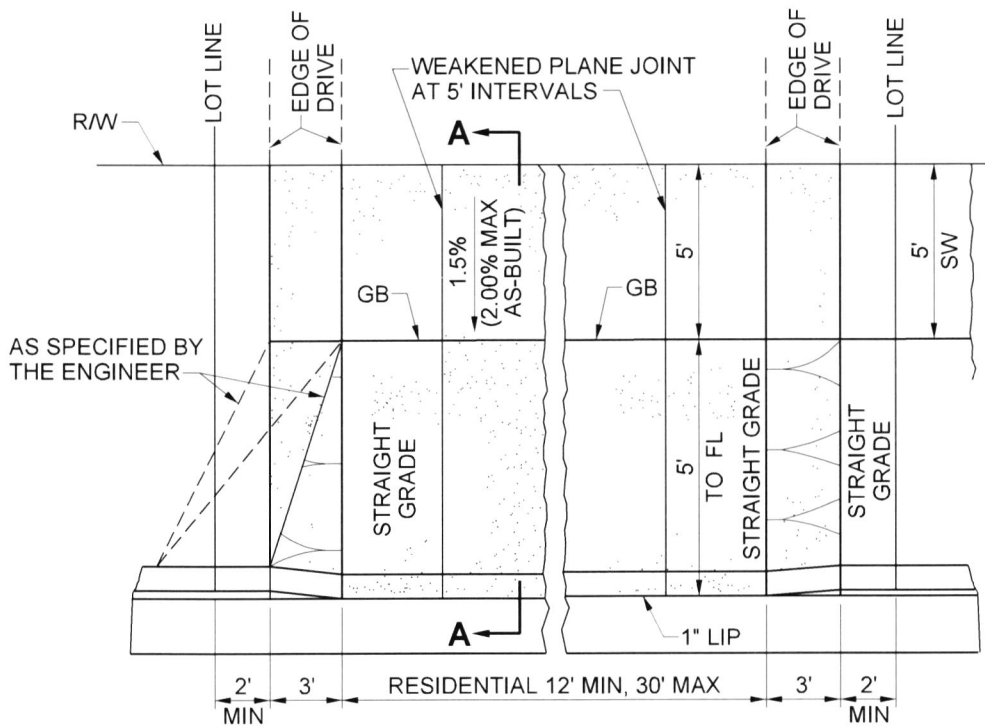

**WHEN NO SIDEWALK EXISTS  
OR IS NOT REQUIRED**

**PLAN**

**WITH SIDEWALK**

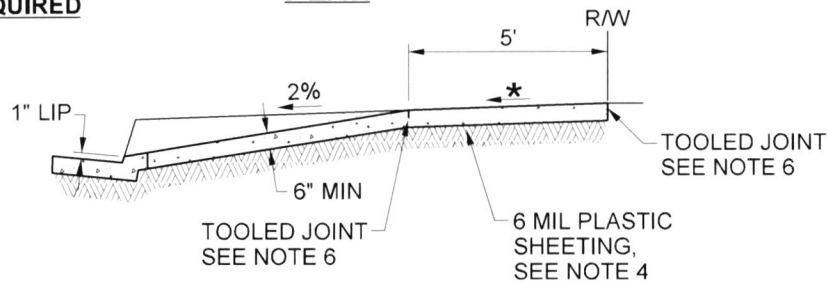

**SECTION "A-A"**

\* CROSS SLOPE OF SIDEWALK SHALL BE 1.5% (2.00% MAX AS-BUILT)

**NOTES:**

1. CONCRETE MINIMUM CEMENTITIOUS MATERIAL CONTENT = 505 LB / CU YD.
2. 20' OF FULL-HEIGHT CURB REQUIRED BETWEEN DRIVEWAYS WITHIN ANY ONE PROPERTY FRONTAGE.
3. ROOT BARRIERS ARE REQUIRED FOR ANY TREES PLANTED WITHIN THE STREET RIGHT OF WAY.
4. WHEN ABUTTING SOIL HAS A HIGH SULFATE CONTENT, USE A MODIFIED CONCRETE MIX AND PLACE 6" MIN CLASS 2 AGGREGATE BASE AND 6 MIL PLASTIC SHEETING UNDER AND AROUND ALL SIDES OF CONCRETE IMPROVEMENTS. FOR EXPANSIVE SOIL, PLACE 6" MIN CLASS 2 AGGREGATE BASE UNDER CONCRETE IMPROVEMENTS AS DIRECTED BY THE ENGINEER. SEE SPECIFICATIONS SECTIONS 16.03 & 16.04 AND STANDARD No. 401 FOR REFERENCE.
5. 8" CURB FACE NOT ALLOWED.
6. APPROACHES SHALL HAVE 1 1/2" DEEP 3/16" WIDE TOOLED JOINT AT CENTER OF APPROACH AND AS SHOWN HEREON. ALL OTHER SCORE LINES SHALL BE 10'-0" MAX OC.
7. RELATIVE COMPACTION OF SUBGRADE UNDER DRIVEWAY SHALL BE 95% MIN.

SEE STANDARD No. 207  
FOR RESIDENTIAL DRIVEWAY  
WITH SIDEWALK AT CURB

NOT TO SCALE

PREPARED UNDER THE SUPERVISION OF:

*Mark Lancaster*  
DIRECTOR OF TRANSPORTATION  
MARK LANCASTER, P.E.      11/30/22  
DATE

REVISION	DESCRIPTION	MARK	DATE	APPROVED

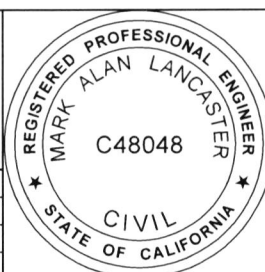

COUNTY OF RIVERSIDE

**RESIDENTIAL DRIVEWAY  
APPROACH WITH  
SIDEWALK AT R/W**

**STANDARD No. 213 (1 OF 2)**

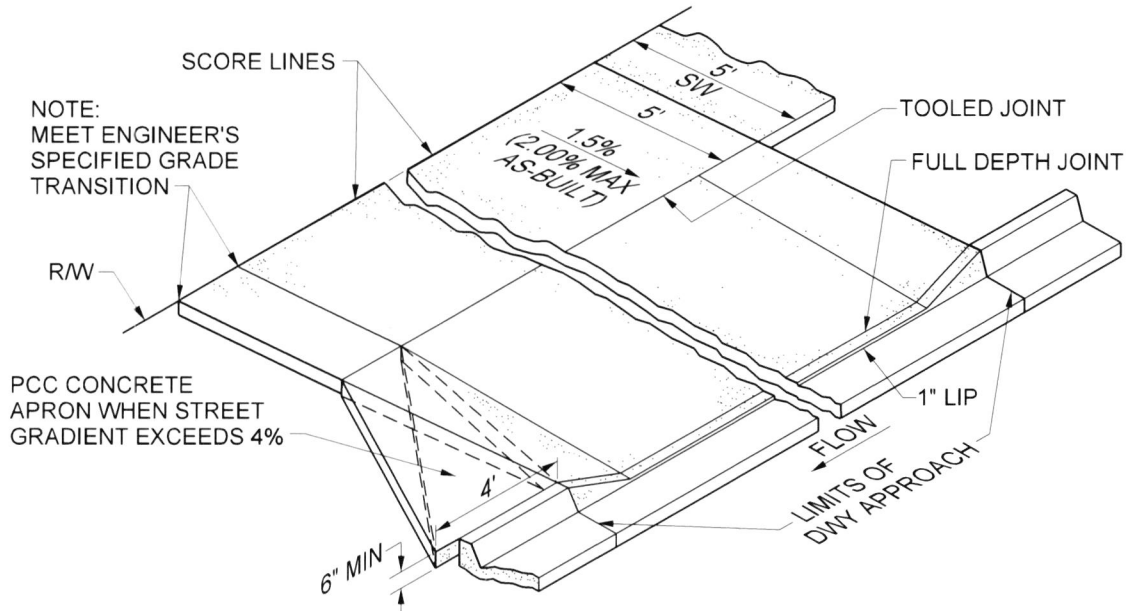

**ISOMETRIC VIEW**

NOT TO SCALE

FOR NOTES SEE SHEET 1

PREPARED UNDER THE SUPERVISION OF:

*Mark Lancaster*

11/30/22

DIRECTOR OF TRANSPORTATION  
MARK LANCASTER, P.E.

DATE



COUNTY OF RIVERSIDE

**RESIDENTIAL DRIVEWAY  
APPROACH WITH  
SIDEWALK AT R/W**

**STANDARD No. 213 (2 OF 2)**

REVISION	DESCRIPTION	MARK	DATE	APPROVED

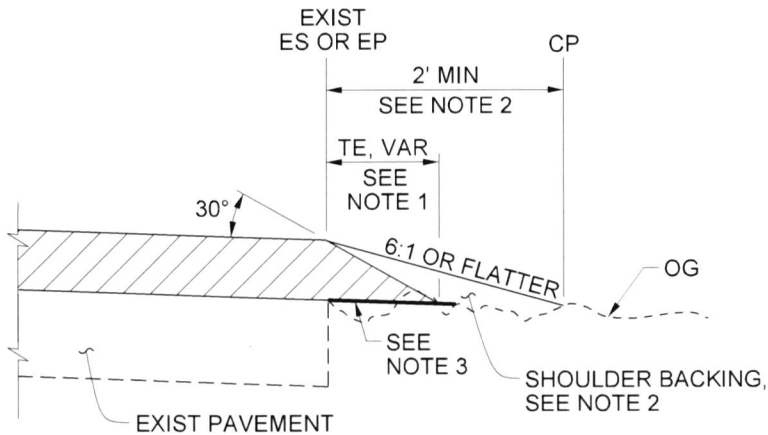

**CASE A**  
TAPERED EDGE

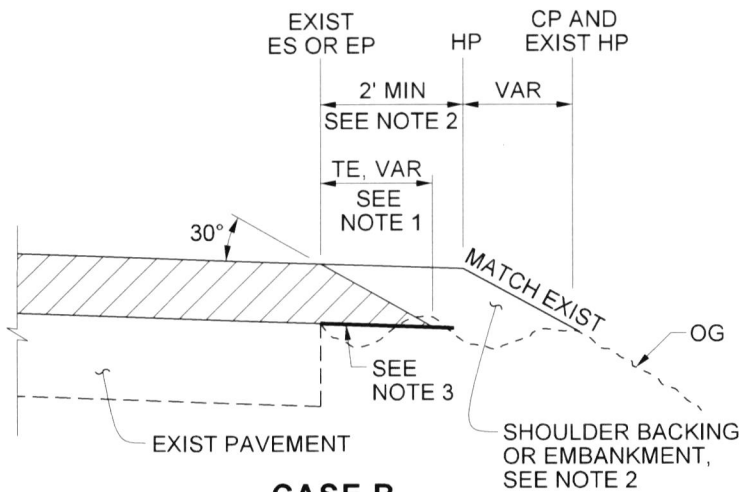

**CASE B**  
TAPERED EDGE

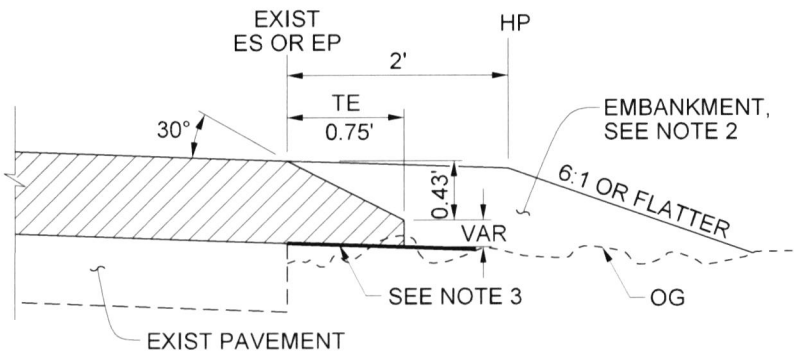

**DETAIL "A"**  
FOR HMA OVERLAY THICKNESS MORE THAN 0.43'.

**LEGEND:**

 HMA OVERLAY

**ABBREVIATIONS:**

TE TAPERED EDGE

**NOTES:**

1. DETAILS SHOWN FOR HMA OVERLAY THICKNESS LESS THAN 0.43'. SEE DETAIL "A" FOR HMA OVERLAY THICKNESS MORE THAN 0.43' OR CONCRETE OVERLAY.
2. FOR LOCATIONS AND LIMITS OF SHOULDER BACKING OR EMBANKMENT SEE PROJECT PLANS.
3. GRADE EXISTING GROUND TO PLACE TAPERED EDGE. 1' MINIMUM WIDTH.

NOT TO SCALE

PREPARED UNDER THE SUPERVISION OF:

*Mark Lancaster*  
DIRECTOR OF TRANSPORTATION  
MARK LANCASTER, P.E.

11/30/22  
DATE



COUNTY OF RIVERSIDE

**SAFETY EDGE**

**STANDARD No. 214 (1 OF 2)**

REVISION	DESCRIPTION	MARK	DATE	APPROVED



**LEGEND:**

 HMA OVERLAY

**ABBREVIATIONS:**

TE TAPERED EDGE  
 HW HINGE WIDTH, DISTANCE FROM EP TO HP

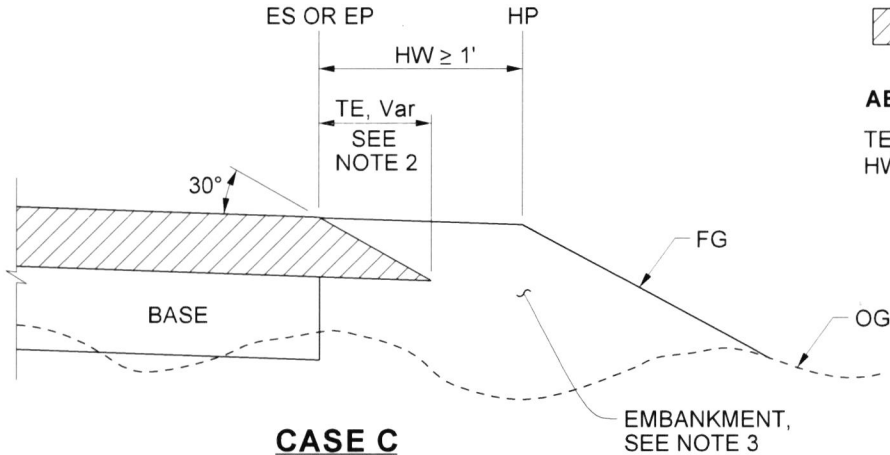

**CASE C**  
 TAPERED EDGE - FILL SECTION, HW ≥ 1'

**FILL SECTION**

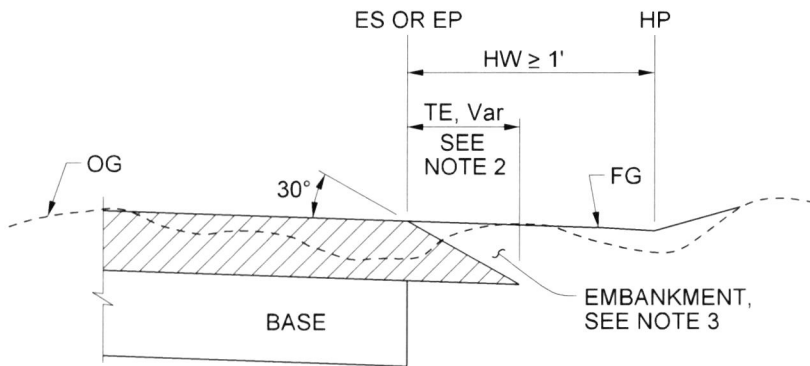

**CASE D**  
 TAPERED EDGE - FILL SECTION, HW ≥ 1'

**CUT SECTION**

**NOTES:**

1. DETAILS SHOWN FOR HMA OVERLAY THICKNESS LESS THAN 0.43'. SEE DETAIL "A" FOR HMA OVERLAY THICKNESS MORE THAN 0.43' OR CONCRETE OVERLAY.
2. FOR LOCATIONS AND LIMITS OF SHOULDER BACKING OR EMBANKMENT SEE PROJECT PLANS.

NOT TO SCALE

PREPARED UNDER THE SUPERVISION OF:

*Mark Lancaster*  
 DIRECTOR OF TRANSPORTATION  
 MARK LANCASTER, P.E.  
 11/30/22  
 DATE



COUNTY OF RIVERSIDE

**SAFETY EDGE**

**STANDARD No. 214 (2 of 2)**

REVISION	DESCRIPTION	MARK	DATE	APPROVED

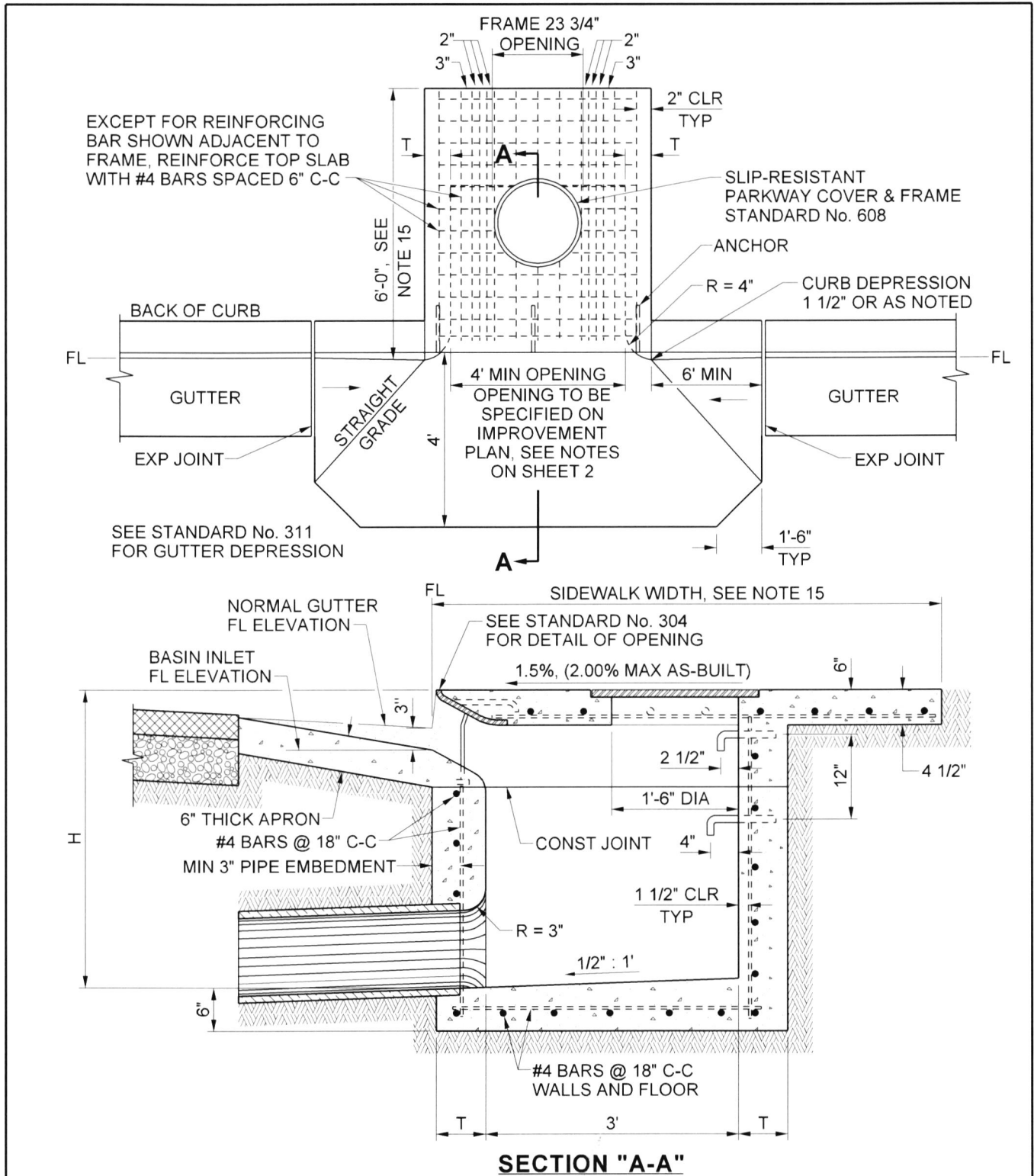

NOT TO SCALE

FOR NOTES SEE SHEET 2

PREPARED UNDER THE SUPERVISION OF:

*Mark Lancaster*

11/30/22  
DATE

DIRECTOR OF TRANSPORTATION  
MARK LANCASTER, P.E.



COUNTY OF RIVERSIDE

**CURB INLET  
CATCH BASIN**

REVISION	DESCRIPTION	MARK	DATE	APPROVED

STANDARD No. 300 (1 OF 2)

**NOTES:**

1. CONNECTION PIPES MAY BE PLACED ANY POSITION AROUND THE WALLS, PROVIDED THEY POINT IN THE PROPER DIRECTION AND THE POSITION IS OTHERWISE CONSISTENT WITH THE IMPROVEMENT PLAN.
2. CURVATURE OF THE LIP AND SIDEWALLS AT GUTTER OPENING SHALL BE FORMED BY CURVED FORMS AND SHALL NOT BE MADE BY PLASTERING.
3. DIMENSIONS:
  - T = 6" IF H IS 8 FEET OR LESS.
  - T = 8" IF H IS GREATER THAN 8 FEET AND LESS THAN 20 FEET.
  - H = 3 FEET 6 INCHES, UNLESS OTHERWISE SPECIFIED.
4. FLOOR OF BASIN SHALL BE GIVEN A STEEL - TROWELLED FINISH.
5. MANHOLE SHALL BE PLACED AS SHOWN ON STANDARD No. 300, UNLESS NOTED DIFFERENTLY ON IMPROVEMENT PLANS.
6. OUTLET PIPE SHALL BE TRIMMED TO THE FINAL SHAPE AND LENGTH BEFORE CONCRETE IS POURED.
7. OPENING SHALL BE 4'-0" MINIMUM UNLESS OTHERWISE SPECIFIED.
8. REINFORCING STEEL SHALL BE NO. 4 ROUND DEFORMED BARS AT 6" CENTERS IN TOP SLAB, AT 18" CENTERS IN SIDES AND FLOOR OF THE BOX.
9. 3/4 INCH PLAIN ROUND HOT-DIP GALVANIZED STEEL STEPS 16" WIDE (ALHAMBRA FDY. A-3325 OR EQUAL) ARE REQUIRED AS FOLLOWS:
  - a. IF H IS 3.5 FEET OR LESS, NO STEPS ARE REQUIRED.
  - b. IF H IS MORE THAN 3.5 FEET, AND NOT MORE THAN 5 FEET, INSTALL 1 STEP 16" ABOVE FLOOR OF THE BASIN.
  - c. IF H IS MORE THAN 5 FEET, INSTALL STEPS 12 INCHES APART, WITH THE TOP STEP 6 INCHES BELOW THE SURFACE OF THE BASIN.
  - d. ALL STEPS SHALL BE 4 INCHES FROM THE WALL, EXCEPT THE TOP STEP, WHICH SHALL BE 2 1/2 INCHES (CLEAR) FROM THE WALL, AND ANCHORED NOT LESS THAN 5 INCHES INTO THE WALL OF THE BASIN.
10. SURFACE OF ALL EXPOSED CONCRETE IN BASIN SHALL CONFORM IN SLOPE, GRADE, COLOR, FINISH AND SCORING TO EXISTING OR PROPOSED CURB AND WALL ADJACENT TO THE BASIN.
11. CONCRETE MINIMUM CEMENTITIOUS MATERIAL CONTENT = 590 LB / CU YD WHEN THE BASIN IS TO BE CONSTRUCTED WITHIN THE LIMITS OF A PROPOSED SIDEWALK OR IS CONTIGUOUS TO SUCH A SIDEWALK. THE TOP OF THE BASIN SHALL BE POURED MONOLITHIC WITH THE SIDEWALK, USING CONCRETE IN THE SIDEWALK WITH MINIMUM CEMENTITIOUS MATERIAL CONTENT = 590 LB / CU YD AND THE TOP OF THE CATCH BASIN PER SIDEWALK STANDARDS.
12. WHEN ABUTTING SOIL HAS A HIGH SULFATE CONTENT, USE A MODIFIED CONCRETE MIX AND PLACE 6" MIN CLASS 2 AGGREGATE BASE AND 6 MIL PLASTIC SHEETING UNDER AND AROUND ALL SIDES OF CONCRETE IMPROVEMENTS. FOR EXPANSIVE SOIL, PLACE 6" MIN CLASS 2 AGGREGATE BASE UNDER CONCRETE IMPROVEMENTS AS DIRECTED BY THE ENGINEER. SEE SPECIFICATIONS SECTIONS 16.03 & 16.04 AND STANDARD No. 401 FOR REFERENCE.
13. CATCH BASINS AND LOCAL DEPRESSIONS MAY NOT BE PLACED WITHIN PEDESTRIAN STREET CROSSINGS.
14. CATCH BASIN CONCRETE MINIMUM CEMENTITIOUS MATERIAL CONTENT = 590 LB / CU YD.
15. TOP OF CATCH BASIN TO BE POURED MONOLITHIC WITH SIDEWALK.

NOT TO SCALE

PREPARED UNDER THE SUPERVISION OF:

*Mark Lancaster*

11/30/22  
DATE

DIRECTOR OF TRANSPORTATION  
MARK LANCASTER, P.E.



COUNTY OF RIVERSIDE

**CURB INLET  
CATCH BASIN**

**STANDARD No. 300 (2 OF 2)**

REVISION	DESCRIPTION	MARK	DATE	APPROVED

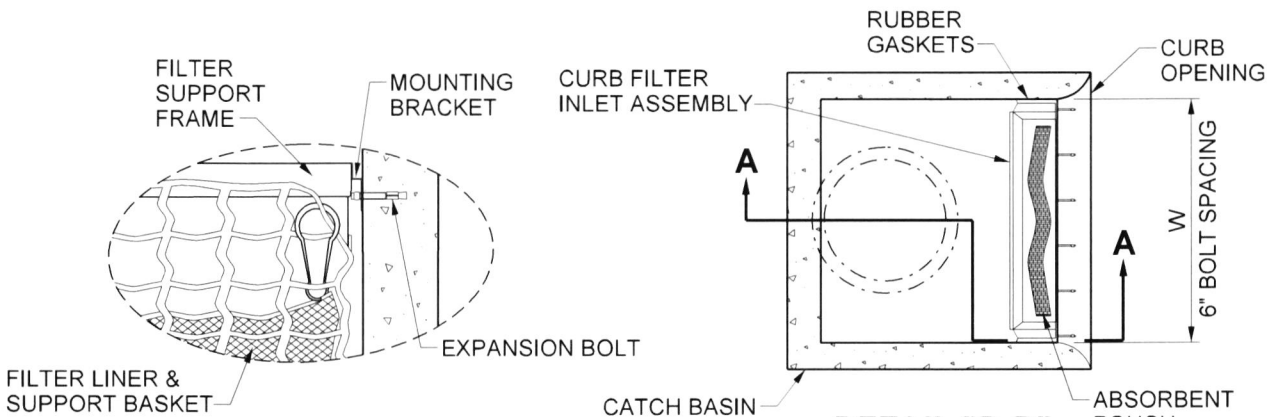

**DETAIL "A"**  
MOUNTING BRACKETS  
& EXPANSION BOLTS  
SEE NOTE 4

**DETAIL "B-B"**  
TOP VIEW

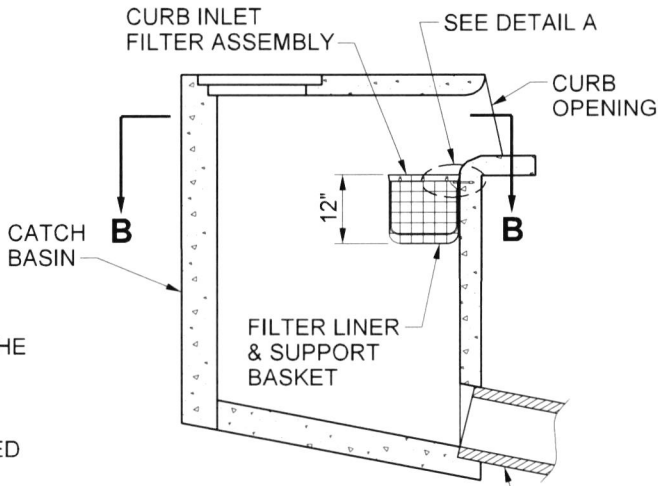

**DETAIL "A-A"**  
SIDE VIEW

**NOTES:**

1. FILTER INSERTS SHALL BE INSTALLED ACROSS THE ENTIRE WIDTH OF THE CURB OPENING, NO GAPS ALONG CURB OPENING SHALL BE PERMITTED.
2. FILTER SUPPORT FRAME SHALL BE CONSTRUCTED FROM STAINLESS STEEL TYPE 304.
3. FILTER LINER SHALL BE CONSTRUCTED FROM DURABLE POLYPROPYLENE, WOVEN, MONOFILAMENT, GEOTEXTILE. FILTER LINER SHALL NOT ALLOW THE RETENTION OF WATER BETWEEN STORM EVENTS. DRAINAGE SHALL BE OUT OF THE BOTTOM OF THE FOSSIL FILTER.
4. FILTER INSERT SHALL BE ATTACHED TO THE CATCH BASIN WITH STAINLESS STEEL EXPANSION ANCHOR BOLTS & WASHERS (3/8" x 2-1/2" MINIMUM LENGTH).
5. FILTER INSERTS SHALL BE AVAILABLE IN STANDARD LENGTHS OF 24", 30", 35", 42" & 48" AND MAY BE INSTALLED IN VARIOUS LENGTH COMBINATIONS (END TO END) TO FIT LENGTH OF NOTED CATCH BASIN.
6. FILTER INSERTS AND FILTER MEDIUM POUCHES MUST BE MAINTAINED IN ACCORDANCE WITH MANUFACTURER RECOMMENDATIONS.
7. FILTER INSERTS SHALL BE DESIGNED WITH A DEBRIS TRAP FOR THE RETENTION OF FLOATABLES AND COLLECTED SEDIMENTS.
8. FILTER INSERTS SHALL BE SUPPLIED WITH "CLIP-IN" FILTER POUCHES UTILIZING FILTER MEDIUM FOR THE COLLECTION AND RETENTION OF PETROLEUM HYDROCARBONS (OILS & GREASES).

NOT TO SCALE

PREPARED UNDER THE SUPERVISION OF:

*Mark Lancaster* 11/30/22  
 DIRECTOR OF TRANSPORTATION DATE  
 MARK LANCASTER, P.E.

REVISION	DESCRIPTION	MARK	DATE	APPROVED



COUNTY OF RIVERSIDE

**FOSSIL FILTER**

**STANDARD No. 300A**

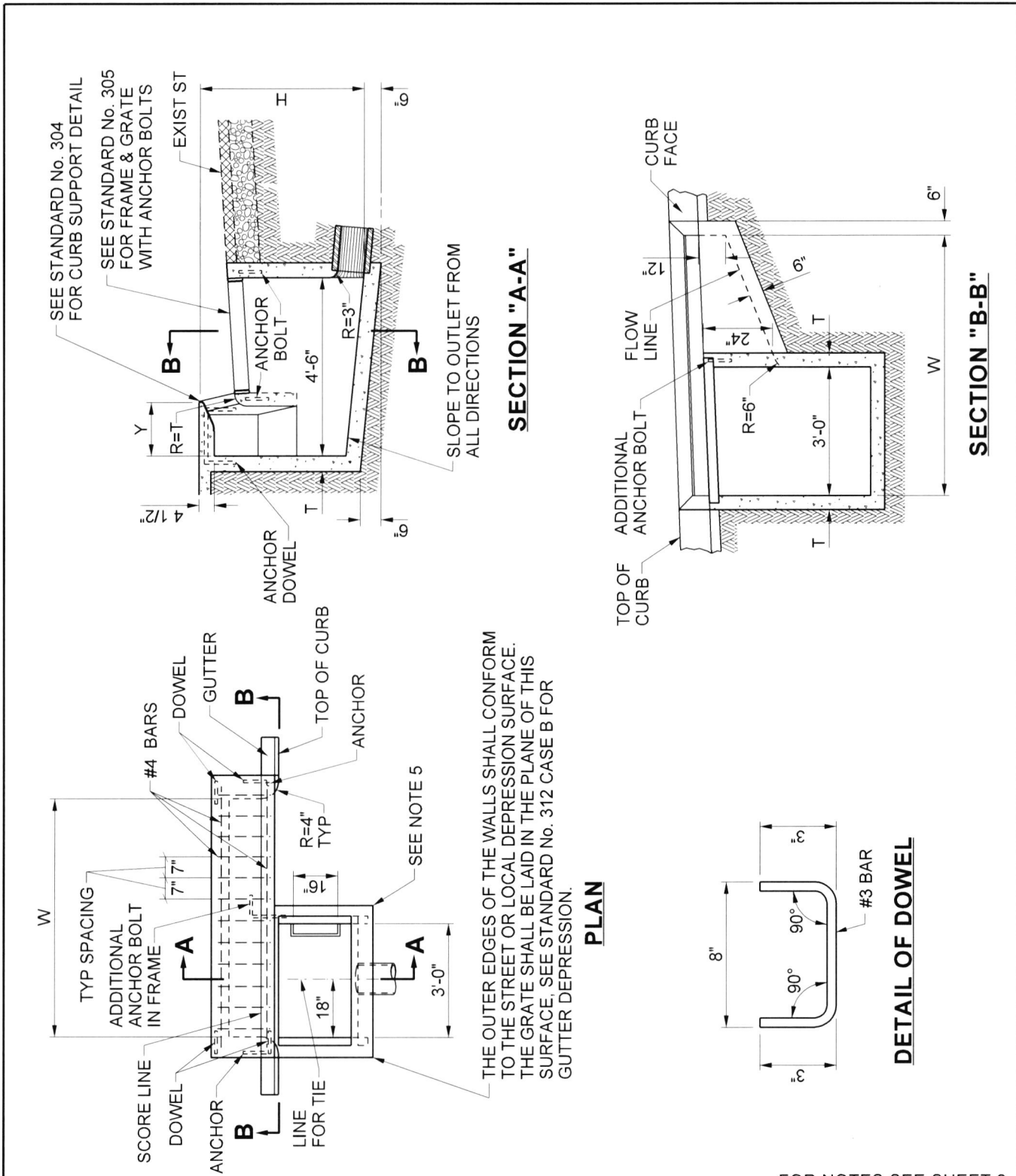

NOT TO SCALE

FOR NOTES SEE SHEET 2

PREPARED UNDER THE SUPERVISION OF:

*Mark Lancaster*  
 DIRECTOR OF TRANSPORTATION  
 MARK LANCASTER, P.E.  
 DATE 11/30/22



COUNTY OF RIVERSIDE

**COMBINATION INLET  
 CATCH BASIN No. 1**

REVISION	DESCRIPTION	MARK	DATE	APPROVED

STANDARD No. 301 (1 OF 2)

**NOTES:**

1. DIMENSIONS UNLESS OTHERWISE SPECIFIED \*

Y	W	T	H
2'-3"	7"*	6"*	4'-6"*
		6"	5' OR LESS
		8"	5' TO 8'
		10"	8' OR GREATER

2. CONCRETE MINIMUM CEMENTITIOUS MATERIAL CONTENT = 590 LB / CU YD.
3. THE REINFORCING STEEL SHALL BE NUMBER 4 DEFORMED BARS. CLEARANCE SHALL BE 1 1/2" FROM THE BOTTOM OF THE SLAB.
4. THE SURFACE OF ALL EXPOSED CONCRETE SHALL CONFORM TO SLOPE, GRADE, COLOR, FINISH, AND SCORE IN THE EXISTING OR PROPOSED CURB AND WALK ADJACENT TO THE BASIN. THE BASIN FLOOR SHALL BE GIVEN A TIGHT WOOD FLOAT FINISH. CURVATURE OF THE LIP AND SIDEWALLS AT THE GUTTER OPENING SHALL NOT BE MADE BY PLASTERING. THE OUTLET PIPE SHALL BE TRIMMED TO FINAL SHAPE AND LENGTH BEFORE THE CONCRETE IS POURED.
5. 3/4 INCH PLAIN ROUND HOT-DIP GALVANIZED STEEL STEPS 16" WIDE (ALHAMBRA FDY. A-3325 OR EQUAL) ARE REQUIRED AS FOLLOWS:
  - a. IF H IS 3.5 FEET OR LESS, NO STEPS ARE REQUIRED.
  - b. IF H IS MORE THAN 3.5 FEET, AND NOT MORE THAN 5 FEET, INSTALL 1 STEP 16" ABOVE FLOOR OF THE BASIN.
  - c. IF H IS MORE THAN 5 FEET, INSTALL STEPS 12 INCHES APART, WITH THE TOP STEP 6 INCHES BELOW THE SURFACE OF THE BASIN.
  - d. ALL STEPS SHALL BE 4 INCHES FROM THE WALL, EXCEPT THE TOP STEP, WHICH SHALL BE 2 1/2 INCHES (CLEAR) FROM THE WALL, AND ANCHORED NOT LESS THAN 5 INCHES INTO THE WALL OF THE BASIN.
6. WHEN ABUTTING SOIL HAS A HIGH SULFATE CONTENT, USE A MODIFIED CONCRETE MIX AND PLACE 6" MIN CLASS 2 AGGREGATE BASE AND 6 MIL PLASTIC SHEETING UNDER AND AROUND ALL SIDES OF CONCRETE IMPROVEMENTS. FOR EXPANSIVE SOIL, PLACE 6" MIN CLASS 2 AGGREGATE BASE UNDER CONCRETE IMPROVEMENTS AS DIRECTED BY THE ENGINEER. SEE SPECIFICATIONS SECTIONS 16.03 & 16.04 AND STANDARD No. 401 FOR REFERENCE.
7. CATCH BASINS, GRATES AND LOCAL DEPRESSIONS MAY NOT BE PLACED WITHIN PEDESTRIAN STREET CROSSINGS. BICYCLE FRIENDLY GRATES SHALL BE USED IN BIKE LANES AND WITHIN ROADBED.

NOT TO SCALE

PREPARED UNDER THE SUPERVISION OF:

*Mark Lancaster*  
 DIRECTOR OF TRANSPORTATION  
 MARK LANCASTER, P.E.

11/30/22  
DATE

REVISION	DESCRIPTION	MARK	DATE	APPROVED

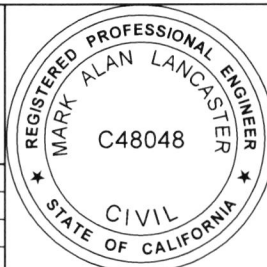

COUNTY OF RIVERSIDE

**COMBINATION INLET  
CATCH BASIN No. 1**

**STANDARD No. 301 (2 OF 2)**

ALHAMBRA FDY.  
A-3320 OR EQUAL  
(GALVANIZED)

#4 DEFORMED BARS  
SPACED 8"

SCORE LINE

NORMAL CURB FACE AT  
EXP JOINT TC & FL  
ELEV AS SPECIFIED ON  
IMPROVEMENT PLANS

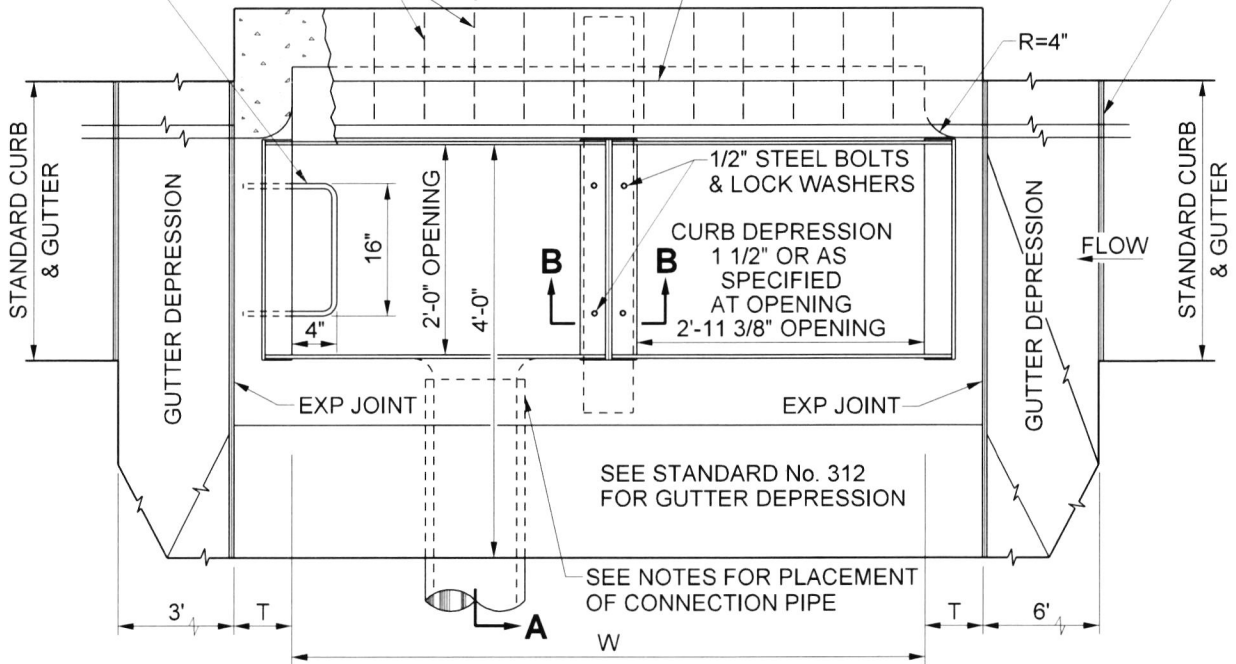

**PLAN**

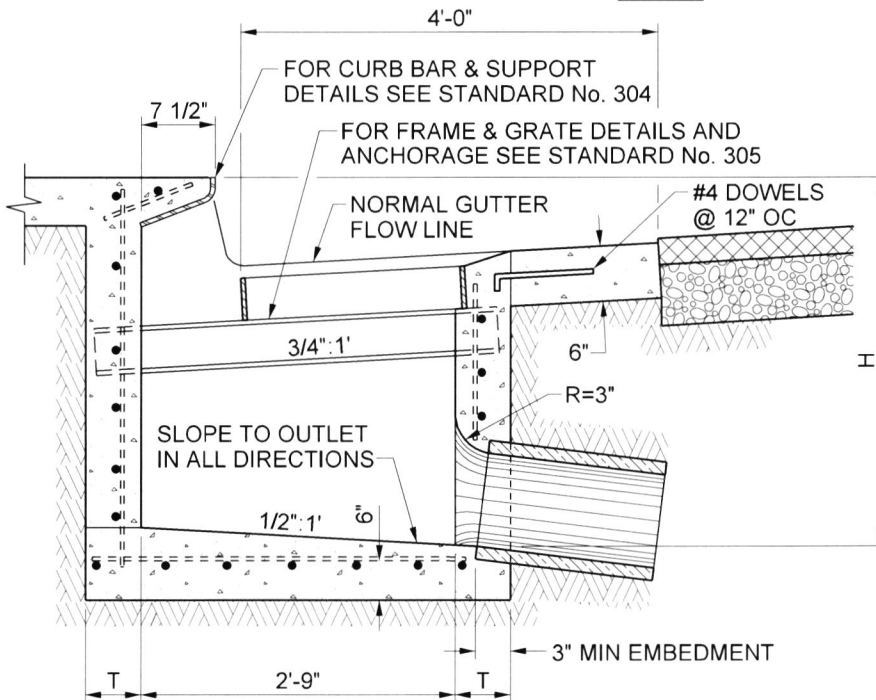

**SECTION "A-A"**

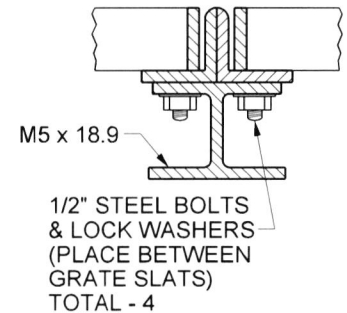

**SECTION "B-B"**

NOT TO SCALE

FOR NOTES SEE SHEET 2

PREPARED UNDER THE SUPERVISION OF:

*Mark Lancaster*  
DIRECTOR OF TRANSPORTATION  
MARK LANCASTER, P.E.

11/30/22  
DATE

REVISION	DESCRIPTION	MARK	DATE	APPROVED



COUNTY OF RIVERSIDE



**COMBINATION INLET  
CATCH BASIN No. 2**

STANDARD No. 302 (1 OF 2)

**NOTES:**

1. BASIN SHALL HAVE ONE GRATE UNLESS OTHERWISE SPECIFIED ON IMPROVEMENT PLANS.
2. CONCRETE MINIMUM CEMENTITIOUS MATERIAL CONTENT = 590 LB / CU YD. WHEN THE BASIN IS TO BE CONSTRUCTED WITHIN THE LIMITS OF A PROPOSED SIDEWALK, OR IS CONTIGUOUS TO SUCH A SIDEWALK, THE TOP OF THE BASIN SHALL BE POURED MONOLITHIC WITH THE SIDEWALK, USING CONCRETE IN THE SIDEWALK WITH MINIMUM CEMENTITIOUS MATERIAL CONTENT = 590 LB / CU YD. THE TOP OF THE CATCH BASIN SHALL BE FINISHED PER SIDEWALK STANDARDS.
3. CONNECTION PIPES MAY BE PLACED IN ANY POSITION AROUND THE WALLS, PROVIDED THEY POINT IN THE PROPER DIRECTION AND THE POSITION IS OTHERWISE CONSISTENT WITH THE IMPROVEMENT PLAN.
4. CURVATURE OF THE END-WALLS AT CURB OPENING SHALL BE FORMED BY CURVED FORMS AND SHALL NOT BE MADE BY PLASTERING.
5. DIMENSIONS:  
 GRATE SHALL BE PARALLEL TO PLANE OF GUTTER SLOPE 3/4" TO 1'-0".  
 T = 6 INCHES IF H IS 8 FEET OR LESS.  
 T = 8 INCHES IF H IS GREATER THAN 8 FEET AND LESS THAN 20 FEET.  
 H = 3 FEET 6 INCHES, UNLESS OTHERWISE SPECIFIED ON IMPROVEMENT PLANS.  
 W = 2 FEET 11 3/8 INCHES FOR ONE GRATE. ADD 3 FEET 5 3/8 INCHES FOR EACH ADDITIONAL GRATE.
6. EXPOSED SURFACES OF THE CATCH BASIN SHALL CONFORM IN SLOPE, GRADE, COLOR, FINISH AND SCORING TO EXISTING IMPROVEMENTS ADJACENT TO THE BASIN. WHERE NO SIDEWALK EXISTS, THE TOP SHALL BE FINISHED TO CONFORM TO STANDARD SIDEWALK SLOPE AND FINISH. WHERE NO CURB EXISTS, THE BATTER OF EXPOSED END WALLS ABOVE THE STREET SURFACE SHALL CONFORM TO BATTER FOR STANDARD CURB.
7. FLOOR OF BASIN SHALL BE GIVEN A STEEL - TROWELLED FINISH.
8. OUTLET PIPE SHALL BE TRIMMED TO THE FINAL SHAPE AND LENGTH BEFORE CONCRETE IS POURED.
9. REINFORCING STEEL SHALL BE #4 DEFORMED BARS. CLEARANCE SHALL BE 1 1/2 INCHES FROM INSIDE OF BOX. SPACING IS AS SHOWN IN TOP SLAB AND AT 18 INCH CENTERS IN SIDES OF BOX.
10. SLOPE OF FLOOR PARALLEL WITH CURB SHALL BE 1 IN 12 UNLESS OTHERWISE SPECIFIED. SLOPE FLOOR FROM ALL DIRECTIONS TO THE OUTLET.
11. STEPS: 3/4 INCH PLAIN ROUND GALVANIZED STEEL STEPS (ALHAMBRA FDY. A-3325 OR EQUAL) ARE REQUIRED AS FOLLOWS:
  - a. IF H IS 3.5 FEET OR LESS, NO STEPS ARE REQUIRED.
  - b. IF H IS MORE THAN 3.5 FEET, AND NOT MORE THAN 5.0 FEET, INSTALL ONE STEP 16" ABOVE FLOOR OF BASIN.
  - c. IF H IS MORE THAN 5.0 FEET, INSTALL STEPS 12 INCHES APART, WITH THE TOP STEP 6" BELOW THE TOP OF GRATE.
  - d. ALL STEPS SHALL BE 4 INCHES CLEAR FROM THE WALL EXCEPT THE TOP STEP, WHICH SHALL BE 2 1/2 INCHES (CLEAR) FROM THE WALL AND ANCHORED NOT LESS THAN 5 INCHES IN WALL OF BASIN.
12. WHEN ABUTTING SOIL HAS A HIGH SULFATE CONTENT, USE A MODIFIED CONCRETE MIX AND PLACE 6" MIN CLASS 2 AGGREGATE BASE AND 6 MIL PLASTIC SHEETING UNDER AND AROUND ALL SIDES OF CONCRETE IMPROVEMENTS. FOR EXPANSIVE SOIL, PLACE 6" MIN CLASS 2 AGGREGATE BASE UNDER CONCRETE IMPROVEMENTS AS DIRECTED BY THE ENGINEER. SEE SPECIFICATIONS SECTIONS 16.03 & 16.04 AND STANDARD No. 401 FOR REFERENCE.
13. GRATE SHALL BE HOT DIPPED GALVANIZED.
14. CATCH BASINS, GRATES AND LOCAL DEPRESSIONS MAY NOT BE PLACED WITHIN PEDESTRIAN STREET CROSSINGS. BICYCLE FRIENDLY GRATES SHALL BE USED IN BIKE LANES AND WITHIN ROADBED.

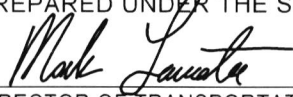
NOT TO SCALE

PREPARED UNDER THE SUPERVISION OF:  DIRECTOR OF TRANSPORTATION MARK LANCASTER, P.E.				11/30/22 DATE		COUNTY OF RIVERSIDE													
<table border="1" style="width: 100%; border-collapse: collapse;"> <thead> <tr> <th style="width: 25%;">REVISION</th> <th style="width: 25%;">DESCRIPTION</th> <th style="width: 10%;">MARK</th> <th style="width: 10%;">DATE</th> <th style="width: 30%;">APPROVED</th> </tr> </thead> <tbody> <tr> <td> </td> <td> </td> <td> </td> <td> </td> <td> </td> </tr> <tr> <td> </td> <td> </td> <td> </td> <td> </td> <td> </td> </tr> </tbody> </table>				REVISION		DESCRIPTION	MARK	DATE	APPROVED										
REVISION	DESCRIPTION	MARK	DATE	APPROVED															
<b>STANDARD No. 302 (2 OF 2)</b>																			



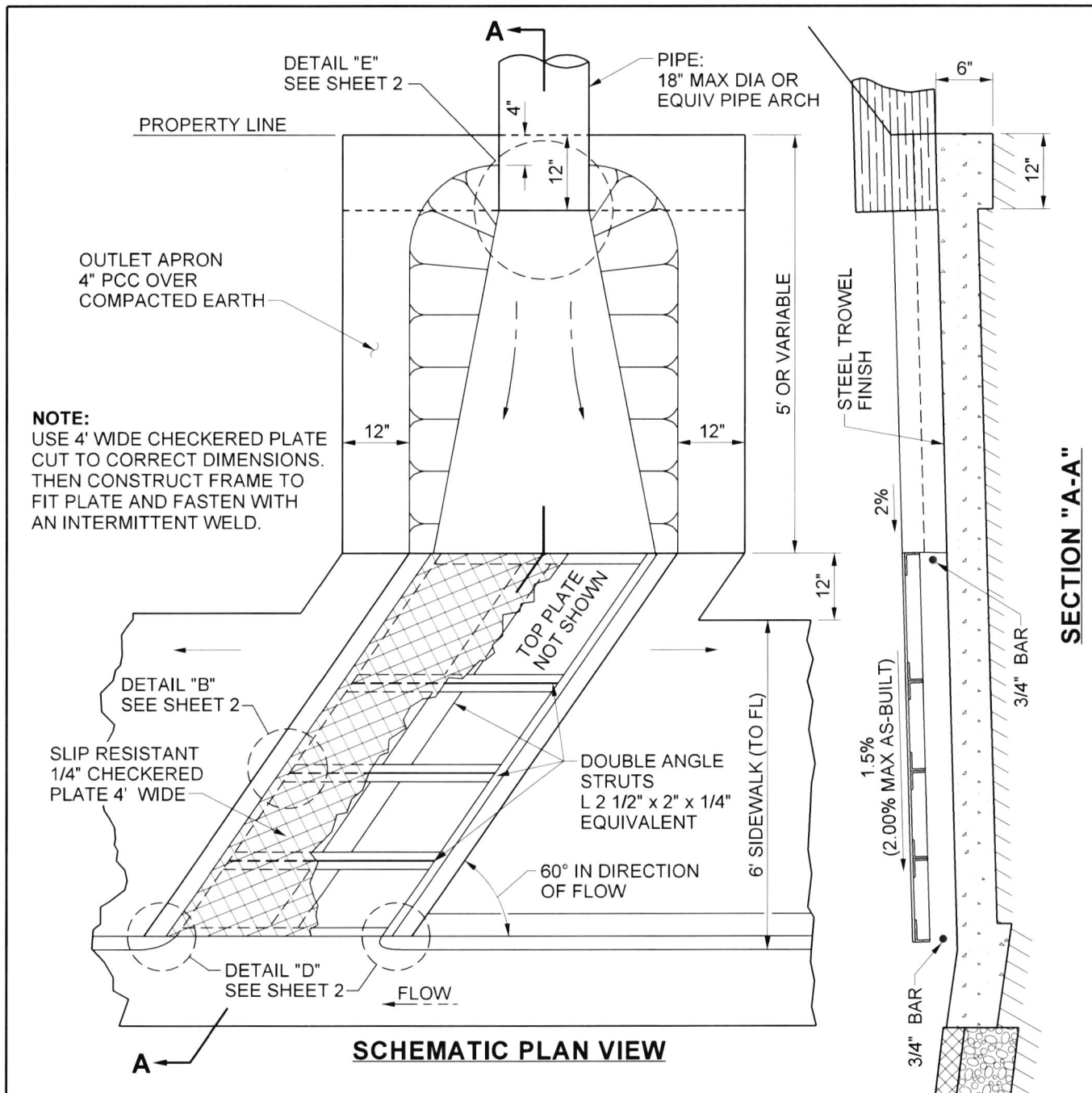

**NOTE:**  
 USE 4" WIDE CHECKERED PLATE CUT TO CORRECT DIMENSIONS. THEN CONSTRUCT FRAME TO FIT PLATE AND FASTEN WITH AN INTERMITTENT WELD.

**SCHMATIC PLAN VIEW**

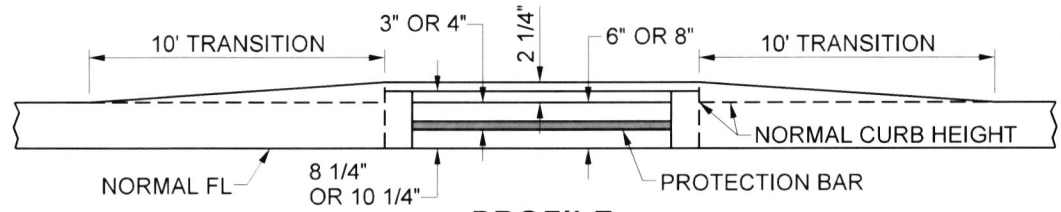

**PROFILE**

NOT TO SCALE

FOR NOTES SEE SHEET 2

PREPARED UNDER THE SUPERVISION OF:

*Mark Lancaster*  
 DIRECTOR OF TRANSPORTATION  
 MARK LANCASTER, P.E.  
 11/30/22  
 DATE



COUNTY OF RIVERSIDE

**FLAT OUTLET  
 DRAINAGE STRUCTURE**

REVISION	DESCRIPTION	MARK	DATE	APPROVED

**STANDARD No. 303 (1 OF 2)**

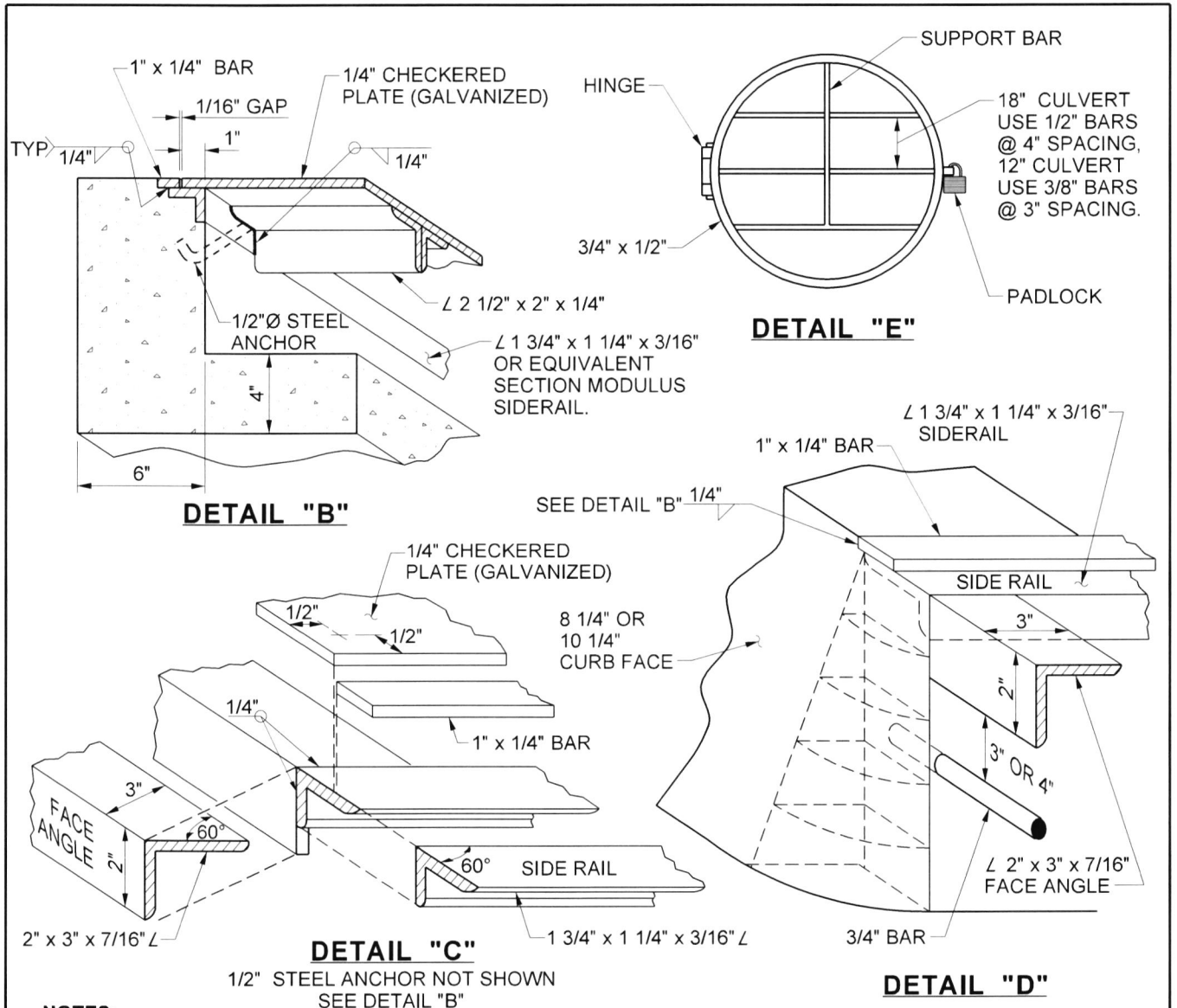

**NOTES:**

1. FRAME AND GRATE SHALL BE CONSTRUCTED TO STANDARD SPECIFICATIONS OR OF EQUIVALENT STRUCTURAL STRENGTH AND WELDED TOGETHER WITH A 1/4" INTERMITTENT WELD AT ALL BREAKS, SEAMS, SECTIONS, JOINTS, ETC.
2. THE 1/4" CHECKERED PLATE SHALL BE FASTENED TO THE FRAME WITH AN INTERMITTENT WELD.
3. GRATE SHALL BE CONSTRUCTED TO STANDARD SPECIFICATIONS, WELDED AT ALL BREAKS, SECTIONS, ETC., HINGED TO DRAINAGE PIPE, AND SECURED WITH PADLOCK. GRATE NOT REQUIRED FOR CULVERTS SMALLER THAN 12".
4. WHEN ABUTTING SOIL HAS A HIGH SULFATE CONTENT, USE A MODIFIED CONCRETE MIX AND PLACE 6" MIN CLASS 2 AGGREGATE BASE AND 6 MIL PLASTIC SHEETING UNDER AND AROUND ALL SIDES OF CONCRETE IMPROVEMENTS. FOR EXPANSIVE SOIL, PLACE 6" MIN CLASS 2 AGGREGATE BASE UNDER CONCRETE IMPROVEMENTS AS DIRECTED BY THE ENGINEER. SEE SPECIFICATIONS SECTIONS 16.03 & 16.04 AND STANDARD No. 401 FOR REFERENCE.
5. ALL METAL SHALL BE HOT DIPPED GALVANIZED.
6. CONCRETE MINIMUM CEMENTITIOUS MATERIAL CONTENT = 590 LB / CU YD.

NOT TO SCALE

PREPARED UNDER THE SUPERVISION OF:

*Mark Lancaster*  
 DIRECTOR OF TRANSPORTATION  
 MARK LANCASTER, P.E.

11/30/22  
 DATE



COUNTY OF RIVERSIDE

**FLAT OUTLET DRAINAGE  
 STRUCTURE**

**STANDARD No. 303 (2 OF 2)**

REVISION	DESCRIPTION	MARK	DATE	APPROVED

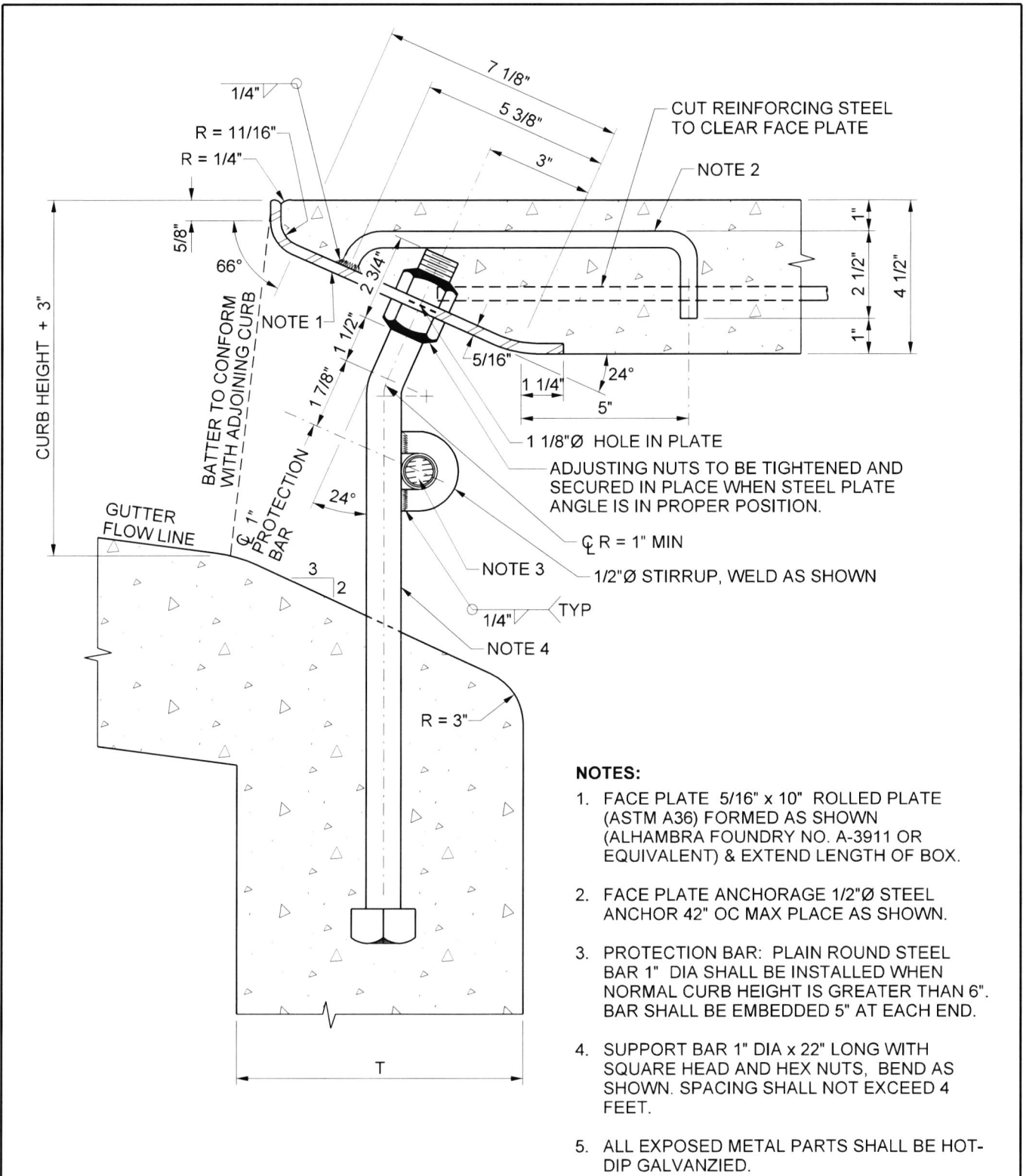

- NOTES:**
1. FACE PLATE 5/16" x 10" ROLLED PLATE (ASTM A36) FORMED AS SHOWN (ALHAMBRA FOUNDRY NO. A-3911 OR EQUIVALENT) & EXTEND LENGTH OF BOX.
  2. FACE PLATE ANCHORAGE 1/2"Ø STEEL ANCHOR 42" OC MAX PLACE AS SHOWN.
  3. PROTECTION BAR: PLAIN ROUND STEEL BAR 1" DIA SHALL BE INSTALLED WHEN NORMAL CURB HEIGHT IS GREATER THAN 6". BAR SHALL BE EMBEDDED 5" AT EACH END.
  4. SUPPORT BAR 1" DIA x 22" LONG WITH SQUARE HEAD AND HEX NUTS, BEND AS SHOWN. SPACING SHALL NOT EXCEED 4 FEET.
  5. ALL EXPOSED METAL PARTS SHALL BE HOT-DIP GALVANIZED.

NOT TO SCALE

PREPARED UNDER THE SUPERVISION OF:

*Mark Lancaster* 11/30/22  
 DIRECTOR OF TRANSPORTATION DATE  
 MARK LANCASTER, P.E.

REVISION	DESCRIPTION	MARK	DATE	APPROVED



COUNTY OF RIVERSIDE

**CURB SUPPORT DETAIL**

STANDARD No. 304

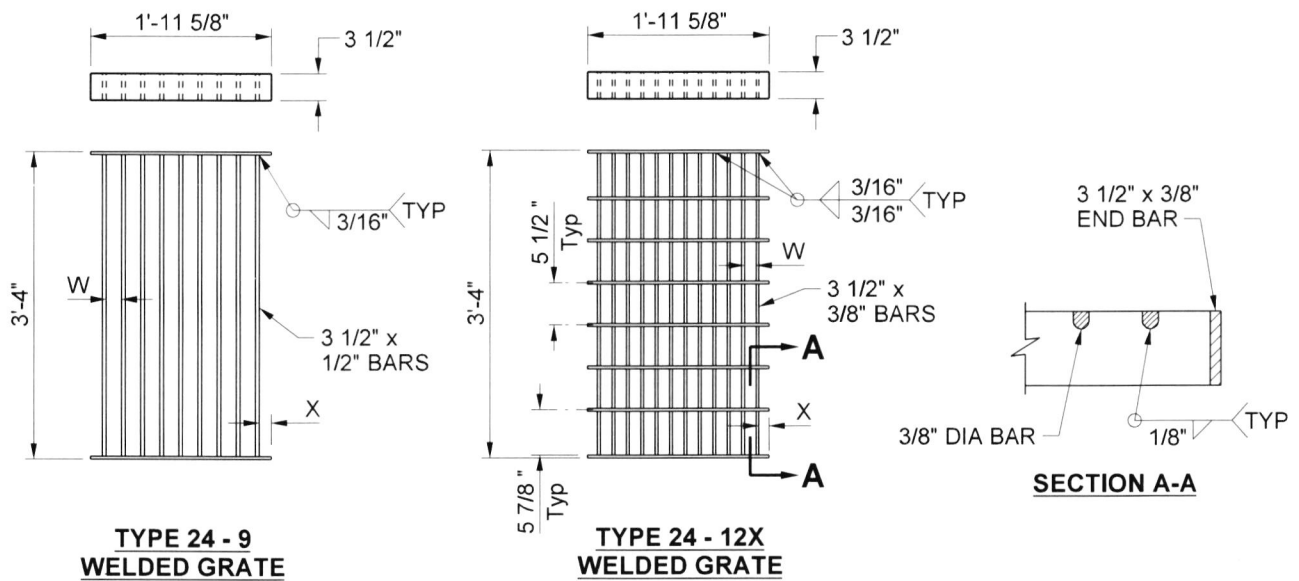

**GRATE DETAILS**  
(SEE TABLE BELOW)

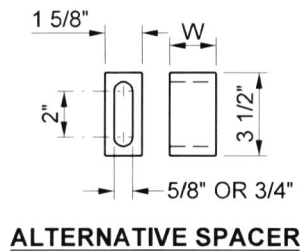
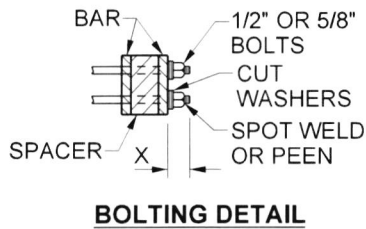
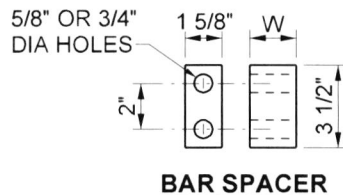
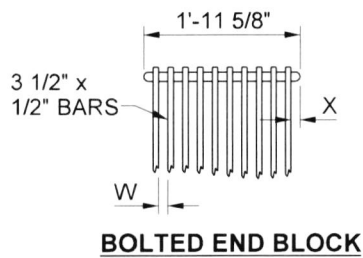

**ALTERNATIVE BOLTED GRATE**

TYPE	NO. BARS	" W "	" X "	GRATE OPEN AREA	USAGE
24 - 9	9	2"	1 9/16"	5.21 SqFt	USE IN LOCATIONS OFF THE ROADBED
24 - 12X	12	1 1/2"	1 5/16"	4.91 SqFt	USE WITHIN THE ROADBED

NOT TO SCALE

PREPARED UNDER THE SUPERVISION OF:

*Mark Lancaster*  
 DIRECTOR OF TRANSPORTATION  
 MARK LANCASTER, P.E.  
 11/30/22  
 DATE

REVISION	DESCRIPTION	MARK	DATE	APPROVED



COUNTY OF RIVERSIDE

**GRATE AND FRAME DETAIL**

**STANDARD No. 305 (1 OF 2)**

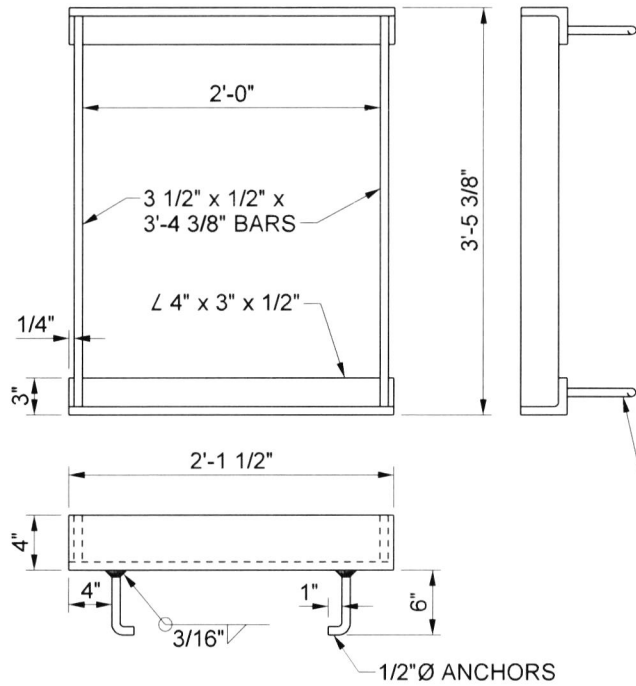

WEIGHTS		
TYPE	WELDED	BOLTED
24 -9	200	230
24 -12X	258	286
24" FRAME	90	-

OMIT ANCHOR  
IF WF BEAM  
SUPPORT IS USED

### FRAME DETAILS

#### NOTES:

1. GRATE TYPE NUMBER REFERS TO WIDTH OF GRATE IN INCHES AND NUMBER OF BARS RESPECTIVELY.
2. CONTRACTOR HAS THE OPTION OF USING WELDED OR BOLTED GRATES.
3. ROUNDED TOP OF BARS OPTIONAL ON ALL GRATES.
4. GRATE SHALL BE PLACED SO THAT BARS ARE PARALLEL TO DIRECTION OF PRINCIPAL SURFACE FLOW.
5. GRATE AND FRAME SHALL BE HOT-DIP GALVANIZED.

NOT TO SCALE

PREPARED UNDER THE SUPERVISION OF:

*Mark Lancaster* 11/30/22  
 DIRECTOR OF TRANSPORTATION DATE  
 MARK LANCASTER, P.E.

REVISION	DESCRIPTION	MARK	DATE	APPROVED



COUNTY OF RIVERSIDE

### GRATE AND FRAME DETAIL

STANDARD No. 305 (2 OF 2)

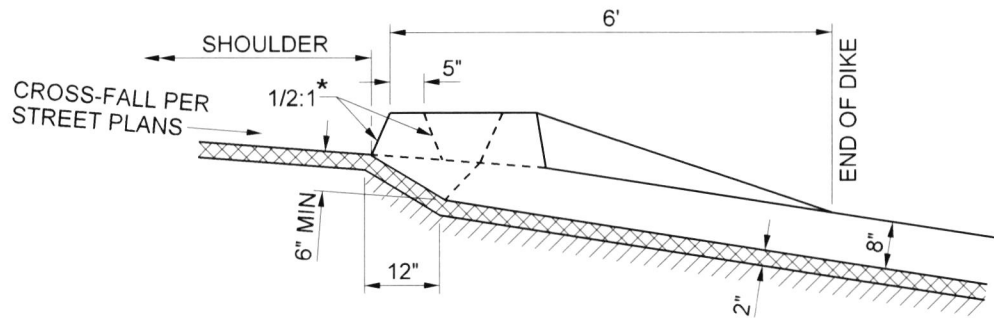
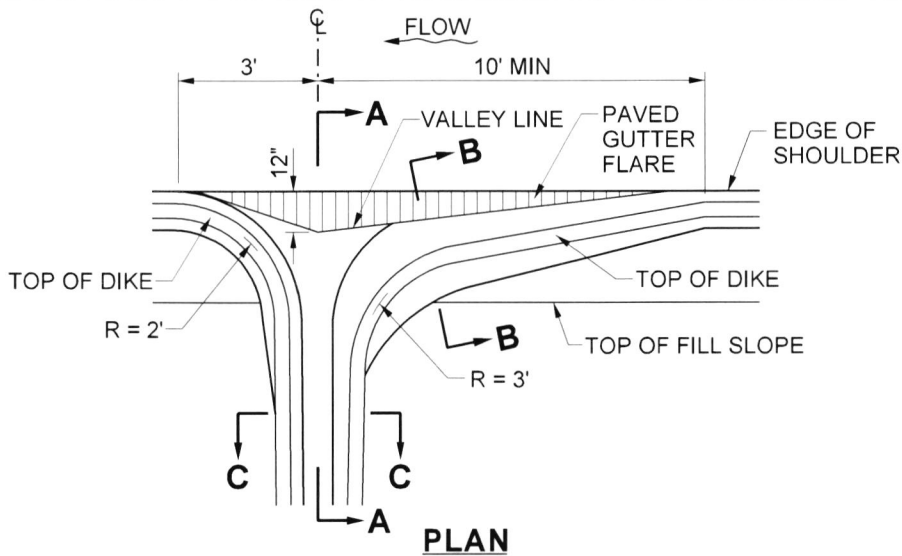

**SECTION "A-A"**

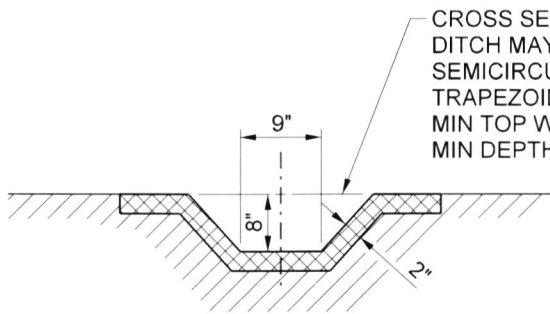

**SECTION "C-C"**

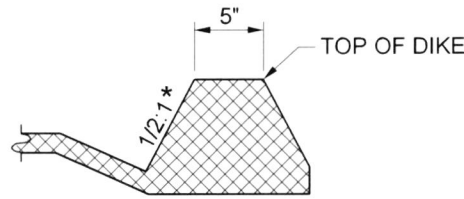

**SECTION "B-B"**

TO BE USED ON FILL SLOPES FLATTER THAN 4:1.  
 USE MINIMUM 10' LENGTH OF GUTTER ON BOTH  
 SIDES IN A SAG LOCATION. USE PIPE DOWNDRAINS  
 FOR SLOPES STEEPER THAN 4:1 SLOPES

\* 1/2:1 MAX, VARIES

NOT TO SCALE

PREPARED UNDER THE SUPERVISION OF:

*Mark Lancaster*  
 DIRECTOR OF TRANSPORTATION  
 MARK LANCASTER, P.E.

11/30/22  
 DATE

REVISION	DESCRIPTION	MARK	DATE	APPROVED



COUNTY OF RIVERSIDE

**HOT MIX ASPHALT  
 OVSIDE DRAIN**

**STANDARD No. 306**

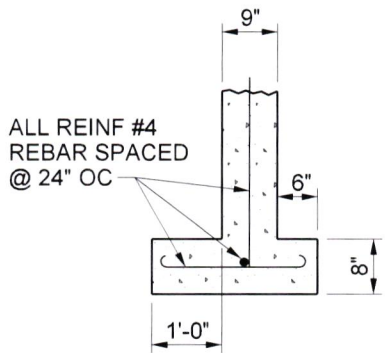
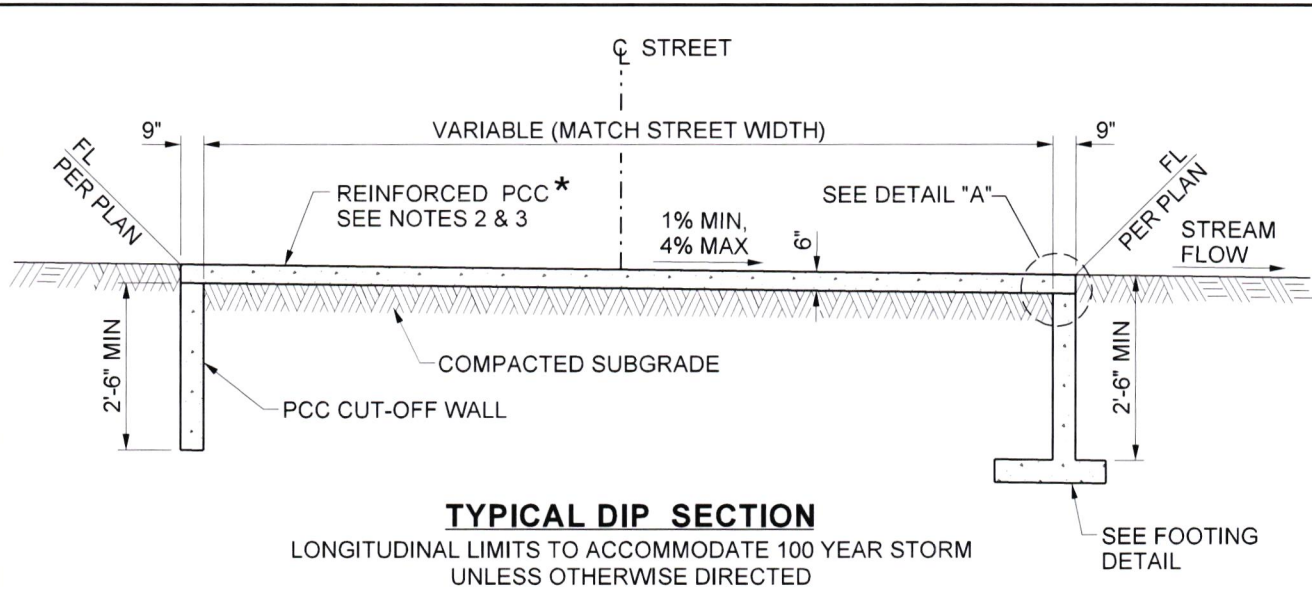

**FOOTING DETAIL**

FOOTING AND DEPTH  
OF CUT-OFF WALL TO  
BE DETERMINED BY  
SOIL INVESTIGATION.

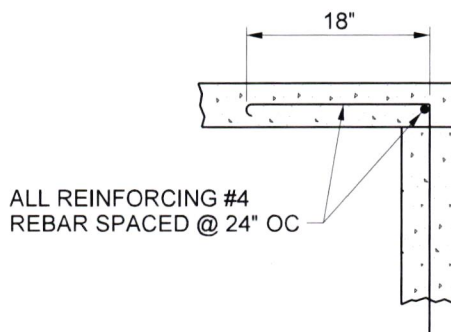

**DETAIL "A"**

**NOTES:**

1. WHEN ABUTTING SOIL HAS A HIGH SULFATE CONTENT, USE A MODIFIED CONCRETE MIX AND PLACE 6" MIN CLASS 2 AGGREGATE BASE AND 6 MIL PLASTIC SHEETING UNDER AND AROUND ALL SIDES OF CONCRETE IMPROVEMENTS. FOR EXPANSIVE SOIL, PLACE 6" MIN CLASS 2 AGGREGATE BASE UNDER CONCRETE IMPROVEMENTS AS DIRECTED BY THE ENGINEER. SEE SPECIFICATIONS SECTIONS 16.03 & 16.04 AND STANDARD No. 401 FOR REFERENCE.
2. REINFORCING FOR PCC PAVEMENT TO CONSIST OF 6" x 6" x 10 GAUGE WIRE MESH.
3. CONCRETE MINIMUM CEMENTITIOUS MATERIAL CONTENT = 590 LB / CU YD.

NOT TO SCALE

PREPARED UNDER THE SUPERVISION OF:

*Mark Lancaster* 11/30/22  
 DIRECTOR OF TRANSPORTATION DATE  
 MARK LANCASTER, P.E.

REVISION	DESCRIPTION	MARK	DATE	APPROVED

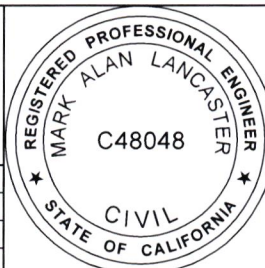

COUNTY OF RIVERSIDE

**PCC DIP SECTION**

**STANDARD No. 307**

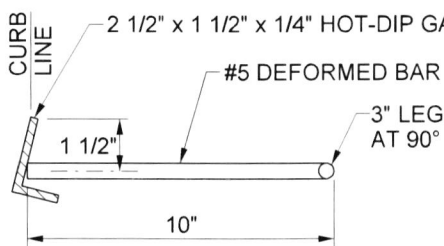

**ANCHOR DETAIL**

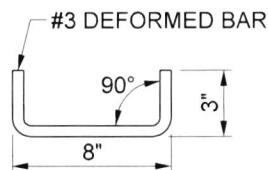

**DOWEL DETAIL**

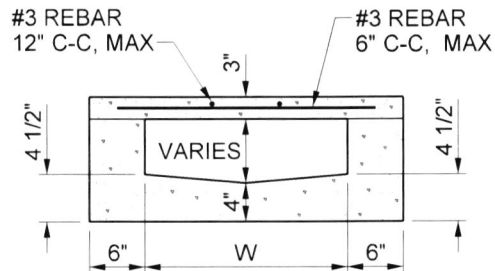

**SECTION "X-X"**

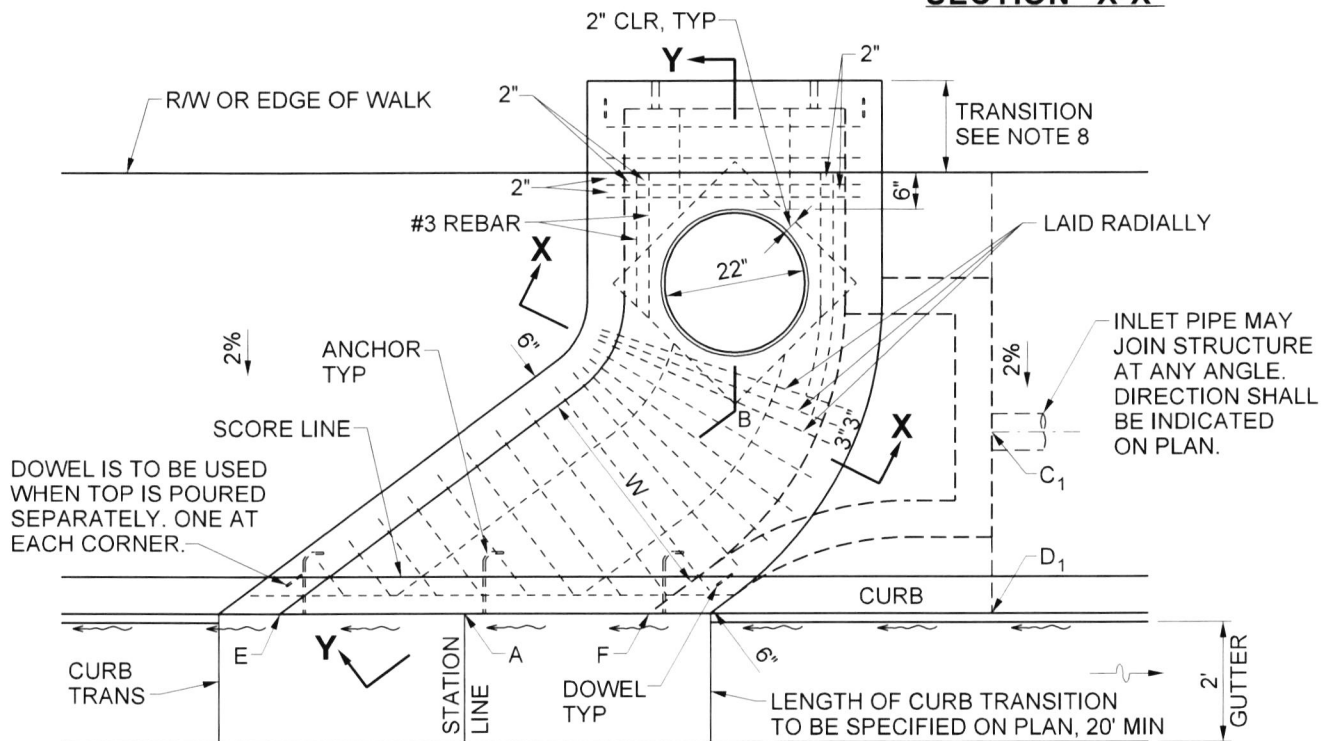

**TOP VIEW**

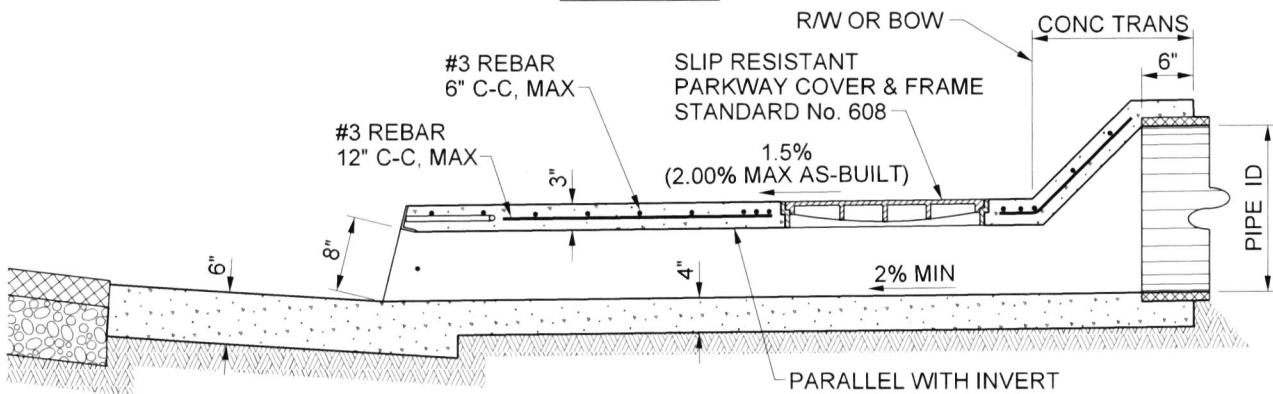

**SECTION "Y-Y"**

NOT TO SCALE

FOR NOTES SEE SHEET 2

PREPARED UNDER THE SUPERVISION OF:

*Mark Lancaster*  
 DIRECTOR OF TRANSPORTATION  
 MARK LANCASTER, P.E.

11/30/22  
 DATE



COUNTY OF RIVERSIDE

**CURB OUTLET DRAIN**

STANDARD No. 308 (1 OF 2)

REVISION DESCRIPTION	MARK	DATE	APPROVED



**NOTES:**

1. WHEN STRUCTURE IS TO BE CONSTRUCTED WITHIN THE LIMITS OF A PROPOSED SIDEWALK OR IS CONTIGUOUS TO SUCH SIDEWALK, THE TOP OF THE STRUCTURE SHALL BE POURED MONOLITHIC WITH THE SIDEWALK, USING THE SAME CLASS OF CONCRETE AS IN THE SIDEWALK.
2. DIMENSIONS SHALL BE AS FOLLOWS UNLESS OTHERWISE SPECIFIED ON THE PLAN:
  - A - B = 5'
  - C<sub>1</sub> - D<sub>1</sub> = 3'
  - E - F = 5'
  - W = 3'
3. FLOOR OF STRUCTURE SHALL BE GIVEN A STEEL-TROWELED FINISH AND CONSTRUCTED ON A STRAIGHT GRADE FROM BACK OF STRUCTURE TO GUTTER FLOW-LINE AT POINT A. THE V-SECTION SPECIFIED FOR INVERT SHALL EXTEND FROM PIPE OUTLET TO A POINT 3' FROM THE GUTTER, FROM WHICH POINT THE INVERT SHALL BE WARPED TO JOIN THE GUTTER FLOW-LINE AT THE STRUCTURE.
4. REINFORCING STEEL BARS SHALL BE 1" FROM BOTTOM OF THE SLAB.
5. SURFACE OF ALL EXPOSED CONCRETE SHALL CONFORM TO EXISTING OR PROPOSED CURB AND WALK ADJACENT TO THE STRUCTURE.
6. CORRUGATED METAL FORMS SHALL NOT BE USED FOR SUPPORTING THE TOP SLAB.
7. TOP OF STRUCTURE SHALL SLOPE 2% TOWARD CURB EXCEPT WHEN OTHERWISE SHOWN ON PLAN OR TO FIT EXISTING SIDEWALK.
8. TRANSITION FROM PIPE TO STRUCTURE, IF REQUIRED, TO BE IN BACK OF SIDEWALK. DIMENSIONS OF TRANSITION SHALL BE SPECIFIED ON THE PLAN.
9. WHEN ABUTTING SOIL HAS A HIGH SULFATE CONTENT, USE A MODIFIED CONCRETE MIX AND PLACE 6" MIN CLASS 2 AGGREGATE BASE AND 6 MIL PLASTIC SHEETING UNDER AND AROUND ALL SIDES OF CONCRETE IMPROVEMENTS. FOR EXPANSIVE SOIL, PLACE 6" MIN CLASS 2 AGGREGATE BASE UNDER CONCRETE IMPROVEMENTS AS DIRECTED BY THE ENGINEER. SEE SPECIFICATIONS SECTIONS 16.03 & 16.04 AND STANDARD No. 401 FOR REFERENCE.
10. CONCRETE MINIMUM CEMENTITIOUS MATERIAL CONTENT = 590 LB / CU YD.

NOT TO SCALE

PREPARED UNDER THE SUPERVISION OF:

*Mark Lancaster*  
 DIRECTOR OF TRANSPORTATION  
 MARK LANCASTER, P.E.

11/30/22  
 DATE

REVISION DESCRIPTION	MARK	DATE	APPROVED



COUNTY OF RIVERSIDE

**CURB OUTLET DRAIN**

**STANDARD No. 308 (2 OF 2)**

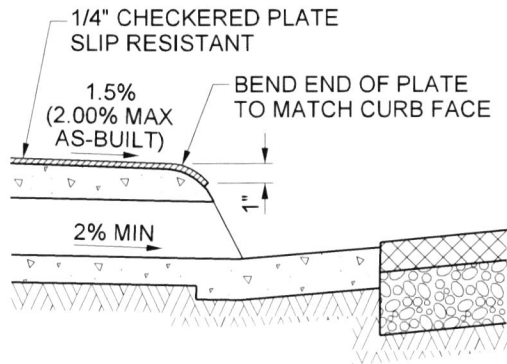
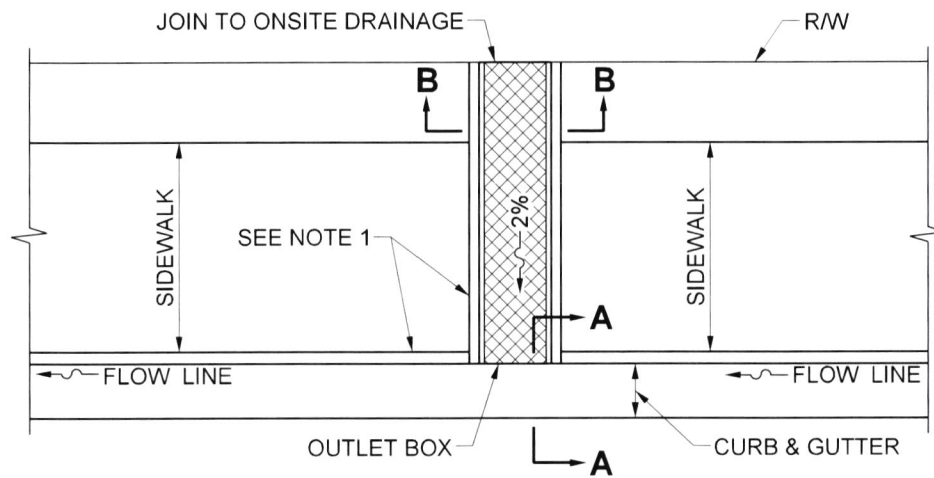

**SECTION "A-A"**

**DRAIN OUTLET**

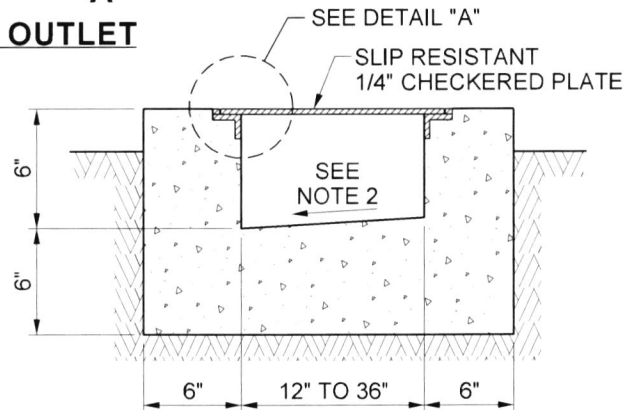

**SECTION "B-B"**

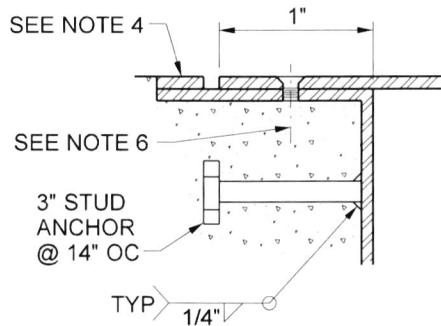

**DETAIL "A"**

**NOTES:**

1. UNDER SIDEWALK DRAIN TO BE CONSTRUCTED PERPENDICULAR (90°) TO THE CURB ALIGNMENT. VARIATIONS FROM 90° REQUIRE THE APPROVAL OF THE DIRECTOR OF TRANSPORTATION.
2. SLOPE TO DRAIN TO ONE SIDE.
3. ALL EXPOSED METAL PARTS TO BE HOT-DIP GALVANIZED AFTER FABRICATION.
4. 1 1/2" x 1 1/2" x 1/4" "L" FRAME WITH 3/8" x 1/4" STEEL STRIP WELDED TO FRAME.
5. CHECKERED PLATE SHALL BE SLIP RESISTANT HOT-DIP GALVANIZED STEEL, MAXIMUM WIDTH 36".
6. FASTEN WITH 1/4" COARSE-THREAD COUNTERSINK STAINLESS STEEL SCREWS AT 12" OC.
7. WHEN ABUTTING SOIL HAS A HIGH SULFATE CONTENT, USE A MODIFIED CONCRETE MIX AND PLACE 6" MIN CLASS 2 AGGREGATE BASE AND 6 MIL PLASTIC SHEETING UNDER AND AROUND ALL SIDES OF CONCRETE IMPROVEMENTS. FOR EXPANSIVE SOIL, PLACE 6" MIN CLASS 2 AGGREGATE BASE UNDER CONCRETE IMPROVEMENTS AS DIRECTED BY THE ENGINEER. SEE SPECIFICATIONS SECTIONS 16.03 & 16.04 AND STANDARD No. 401 FOR REFERENCE.
8. CONCRETE MINIMUM CEMENTITIOUS MATERIAL CONTENT = 505 LB / CU YD.

NOT TO SCALE

PREPARED UNDER THE SUPERVISION OF:

*Mark Lancaster*  
 DIRECTOR OF TRANSPORTATION  
 MARK LANCASTER, P.E.

11/30/22  
 DATE

REVISION	DESCRIPTION	MARK	DATE	APPROVED



COUNTY OF RIVERSIDE

**UNDER SIDEWALK  
 DRAIN  
 CAST IN PLACE**

**STANDARD No. 309**

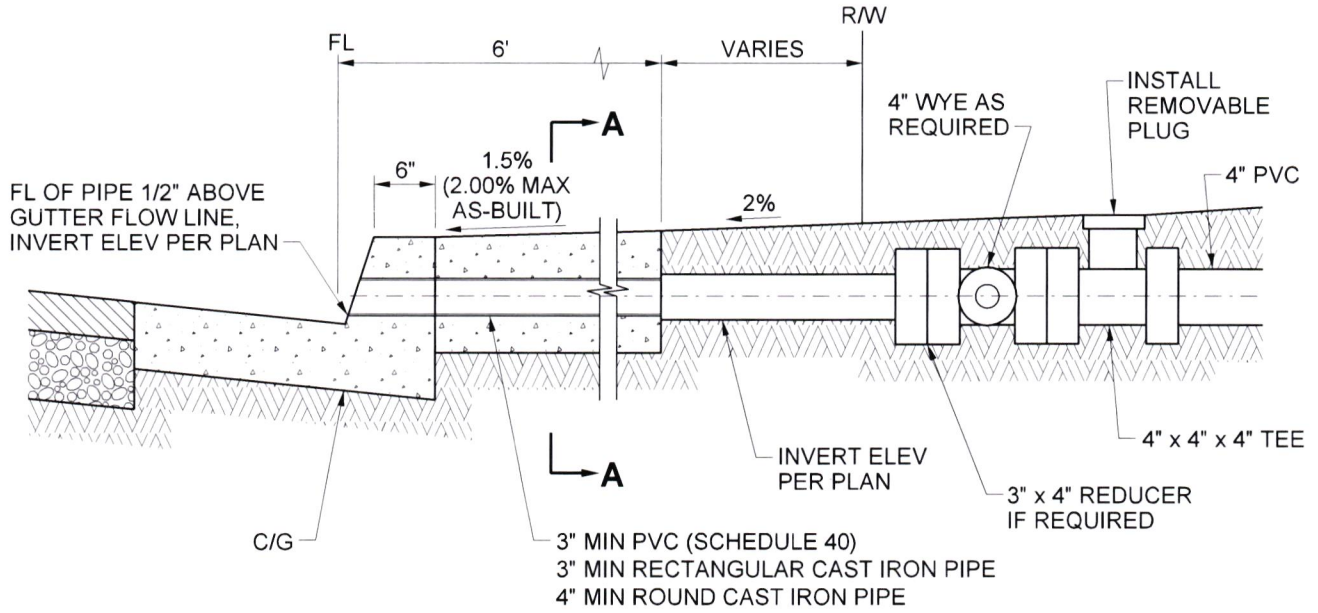

**ELEVATION**

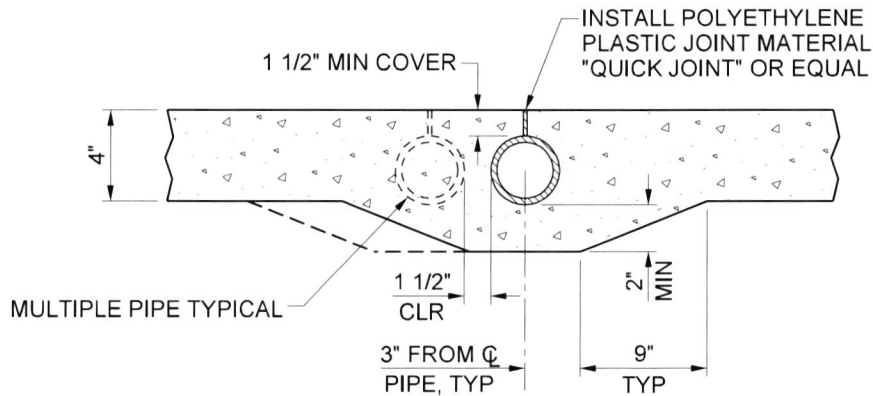

**SECTION "A-A"**

CONCRETE MINIMUM CEMENTITIOUS MATERIAL CONTENT = 505 LB / CU YD

NOT TO SCALE

PREPARED UNDER THE SUPERVISION OF:

*Mark Lancaster*  
 DIRECTOR OF TRANSPORTATION  
 MARK LANCASTER, P.E.  
 11/30/22  
 DATE

REVISION DESCRIPTION	MARK	DATE	APPROVED



COUNTY OF RIVERSIDE

**PRIVATE DRAIN  
 THROUGH CURB**

**STANDARD No. 310**

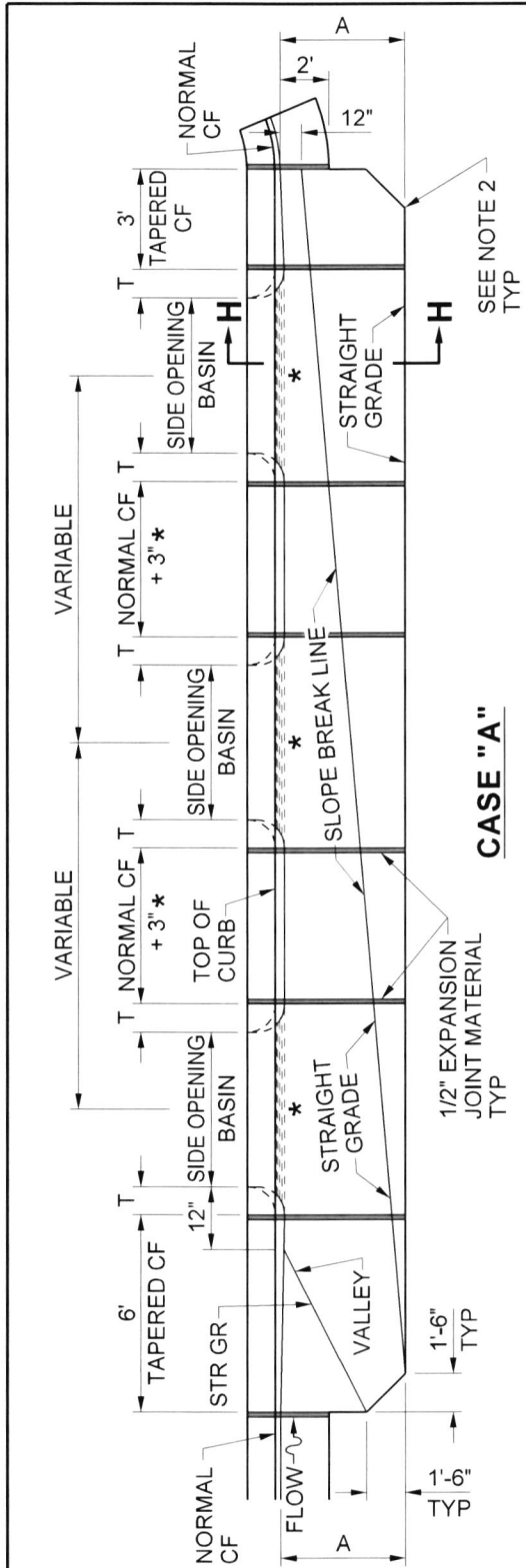

**CASE "A"**

SEE NOTE 2 TYP

1/2" EXPANSION JOINT MATERIAL TYP

VARIABLE

VARIABLE

3'

12"

2'

12"

1'-6"

1'-6"

1'-6"

1'-6"

1'-6"

NOTES:

- GUTTER DEPRESSION SHALL BE CASE B UNLESS OTHERWISE SPECIFIED ON PROJECT DRAWINGS.
- ELEVATIONS OF OUTER CORNERS SHOWN ON PROJECT. IF NO ELEVATIONS ARE SPECIFIED, THE OUTER EDGE OF GUTTER DEPRESSION SHALL CONFORM TO FINISHED STREET SURFACE.
- A = 4 FEET UNLESS OTHERWISE SPECIFIED.  
T = SEE STANDARD No. 300 DIMENSIONS.  
W = 4 FEET MIN, UNLESS OTHERWISE SPECIFIED.
- WHERE NO CURB EXISTS, CURBS SHALL BE CONSTRUCTED BETWEEN ENDS OF GUTTER DEPRESSION. CURB SECTION SHALL CONFORM TO THAT OF CONTROLLING AGENCY.
- DEPRESSION SHALL BE CONCRETE WITH MINIMUM CEMENTITIOUS MATERIAL CONTENT = 505 LB / CU YD.
- WHEN ABUTTING SOIL HAS A HIGH SULFATE CONTENT, USE A MODIFIED CONCRETE MIX AND PLACE 6" MIN CLASS 2 AGGREGATE BASE AND 6 MIL PLASTIC SHEETING UNDER AND AROUND ALL SIDES OF CONCRETE IMPROVEMENTS. FOR EXPANSIVE SOIL, PLACE 6" MIN CLASS 2 AGGREGATE BASE UNDER CONCRETE IMPROVEMENTS AS DIRECTED BY THE ENGINEER. SEE SPECIFICATIONS SECTIONS 16.03 & 16.04 AND STANDARD No. 401 FOR REFERENCE.

\* CATCH BASIN OPENING = NORMAL CURB HEIGHT + 3 INCHES UNLESS OTHERWISE SPECIFIED.

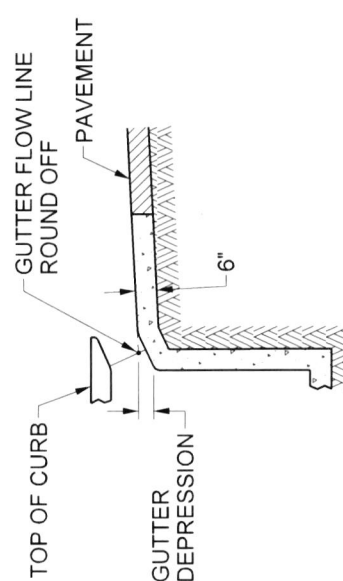

**SECTION "H-H"**

NOT TO SCALE

PREPARED UNDER THE SUPERVISION OF:

*Mark Lancaster*  
 DIRECTOR OF TRANSPORTATION  
 MARK LANCASTER, P.E.  
 11/30/22  
 DATE

REVISION	DESCRIPTION	MARK	DATE	APPROVED



COUNTY OF RIVERSIDE

**GUTTER DEPRESSION FOR CURB OPENING CATCH BASINS**

STANDARD No. 311 (1 OF 2)

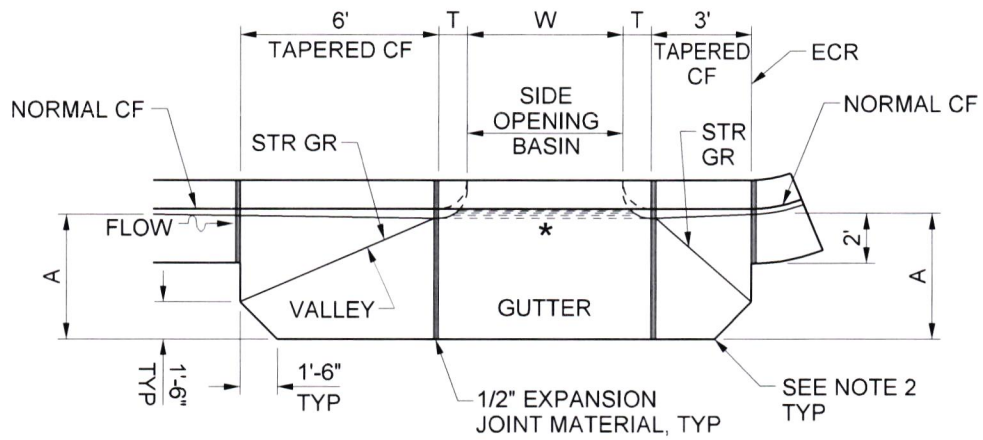

**CASE "B"**  
(CONTINUOUS GRADE)

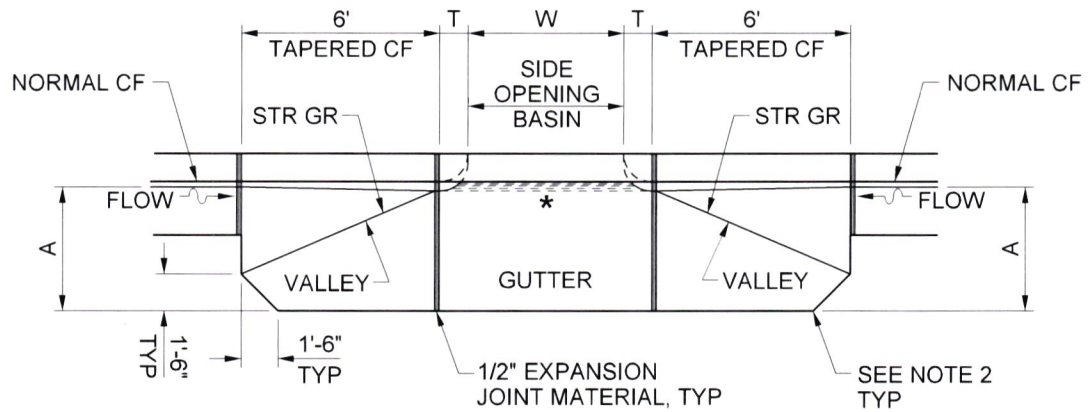

**CASE "C"**  
(SAG)

NOT TO SCALE

FOR NOTES SEE SHEET 1

PREPARED UNDER THE SUPERVISION OF:

*Mark Lancaster*  
DIRECTOR OF TRANSPORTATION  
MARK LANCASTER, P.E.

11/30/22  
DATE



COUNTY OF RIVERSIDE

**GUTTER DEPRESSION  
FOR CURB OPENING  
CATCH BASINS**

**STANDARD No. 311 (2 OF 2)**

REVISION	DESCRIPTION	MARK	DATE	APPROVED

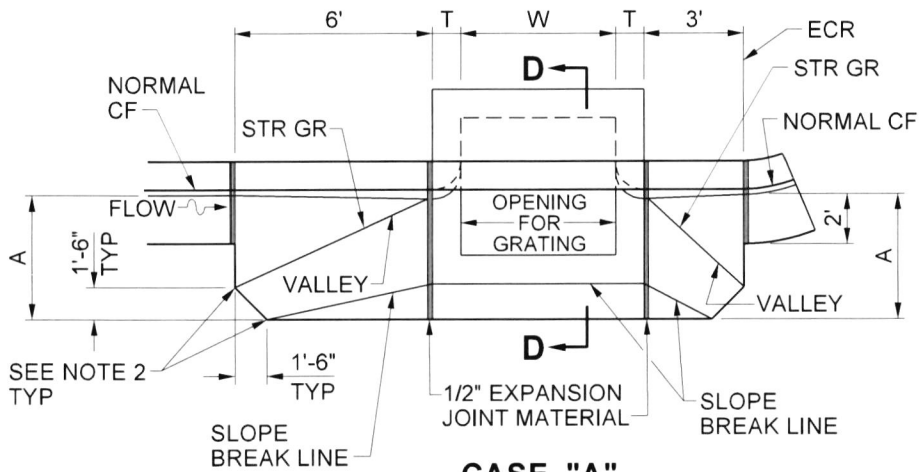

**CASE "A"**

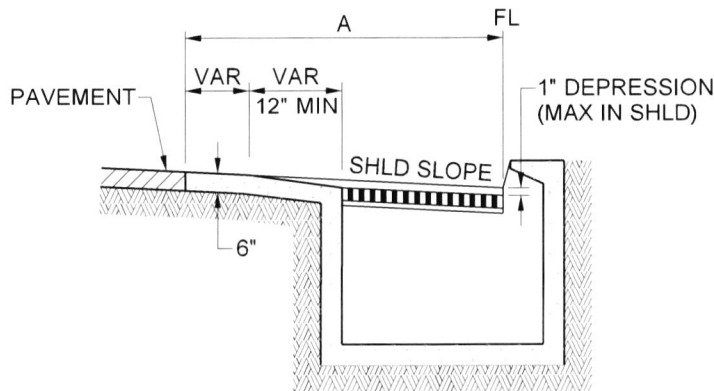

**SECTION "D-D"**

**NOTES:**

1. GUTTER DEPRESSION SHALL BE:
  - (A) CASE "A" SEE STANDARD No. 302 COMBINATION CATCH BASIN, UNLESS OTHERWISE SPECIFIED.
  - (B) CASE "B" SEE STANDARD No. 301 COMBINATION INLET CATCH BASIN, UNLESS OTHERWISE SPECIFIED.
2. ELEVATIONS AT OUTER CORNERS SHOWN ON THE PROJECT DRAWINGS. IF NO ELEVATIONS ARE SPECIFIED THE OUTER EDGE OF THE GUTTER DEPRESSION SHALL CONFORM TO THE FINISHED STREET SURFACE.
3. A = 4' UNLESS OTHERWISE SPECIFIED  
 T = SEE STANDARD No. 302 DIMENSIONS  
 W = SEE STANDARD No. 302 DIMENSIONS
4. WHERE NO CURB EXISTS, CURB SHALL BE CONSTRUCTED BETWEEN ENDS OF GUTTER DEPRESSION. CURB SECTION SHALL CONFORM TO THAT OF CONTROLLING AGENCY.
5. DEPRESSION SHALL BE CONCRETE WITH MINIMUM CEMENTITIOUS MATERIAL CONTENT = 505 LB / CU YD.
6. WHEN ABUTTING SOIL HAS A HIGH SULFATE CONTENT, USE A MODIFIED CONCRETE MIX AND PLACE 6" MIN CLASS 2 AGGREGATE BASE AND 6 MIL PLASTIC SHEETING UNDER AND AROUND ALL SIDES OF CONCRETE IMPROVEMENTS. FOR EXPANSIVE SOIL, PLACE 6" MIN CLASS 2 AGGREGATE BASE UNDER CONCRETE IMPROVEMENTS AS DIRECTED BY THE ENGINEER. SEE SPECIFICATIONS SECTIONS 16.03 & 16.04 AND STANDARD No. 401 FOR REFERENCE.

NOT TO SCALE

PREPARED UNDER THE SUPERVISION OF:

*Mark Lancaster*  
 DIRECTOR OF TRANSPORTATION  
 MARK LANCASTER, P.E.

11/30/22  
 DATE



COUNTY OF RIVERSIDE

**GUTTER DEPRESSION  
 FOR GRATE OPENING  
 CATCH BASIN**

**STANDARD No. 312 (1 OF 2)**

REVISION	DESCRIPTION	MARK	DATE	APPROVED

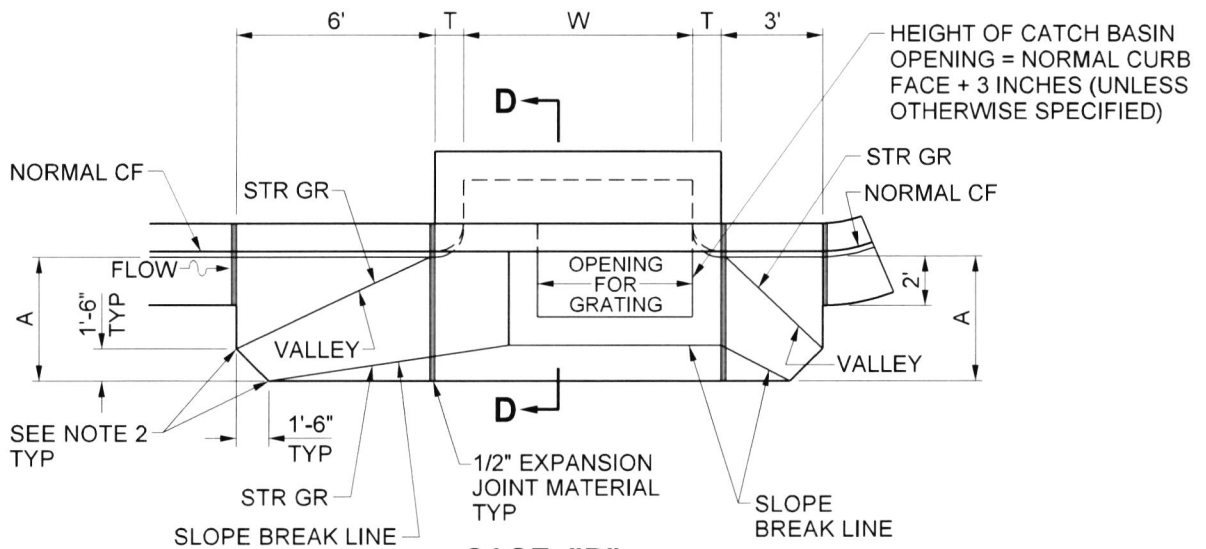

**CASE "B"**

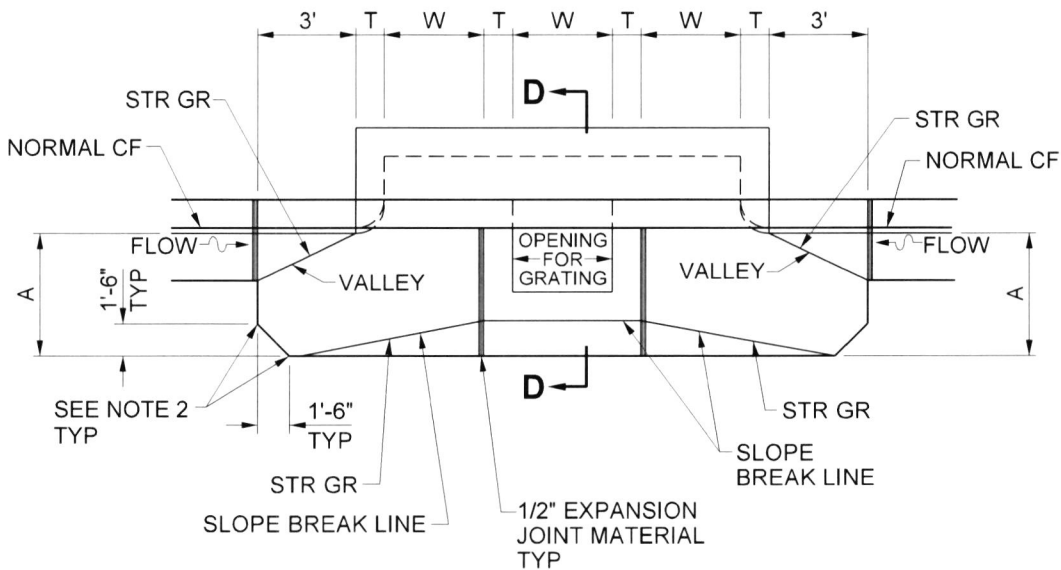

**CASE "C"**

NOT TO SCALE

FOR NOTES & SECTION D-D SEE SHEET 1

PREPARED UNDER THE SUPERVISION OF:

*Mark Lancaster*  
 DIRECTOR OF TRANSPORTATION  
 MARK LANCASTER, P.E.

11/30/22  
 DATE

REVISION	DESCRIPTION	MARK	DATE	APPROVED



COUNTY OF RIVERSIDE

**GUTTER DEPRESSION  
 FOR GRATE OPENING  
 CATCH BASIN**

STANDARD No. 312 (2 OF 2)

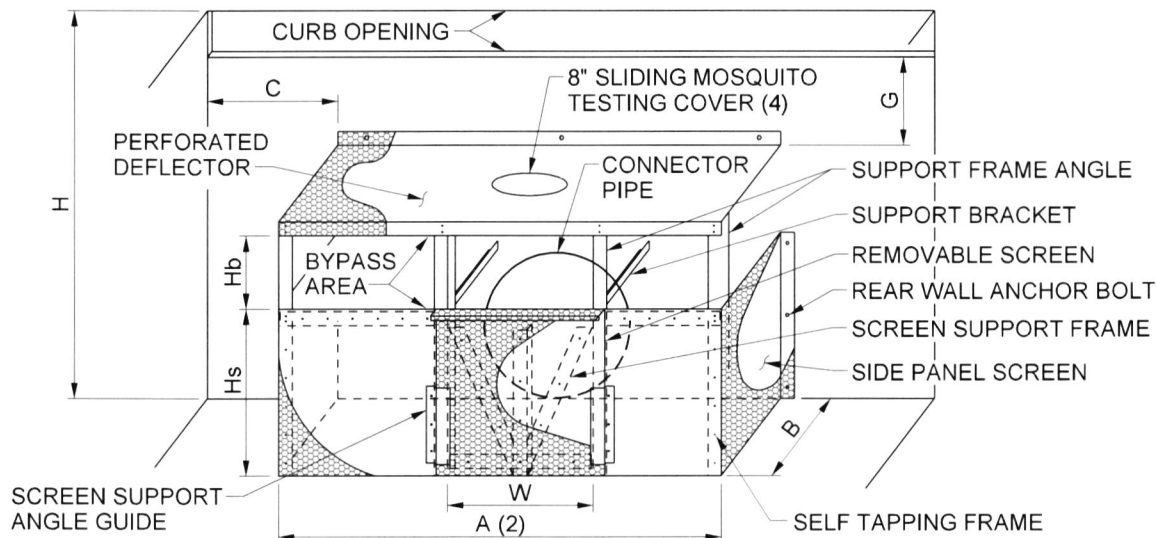

**TYPE A (BACK WALL MOUNT)**

$L = A + 2B$  (FOR TYPE A ONLY)

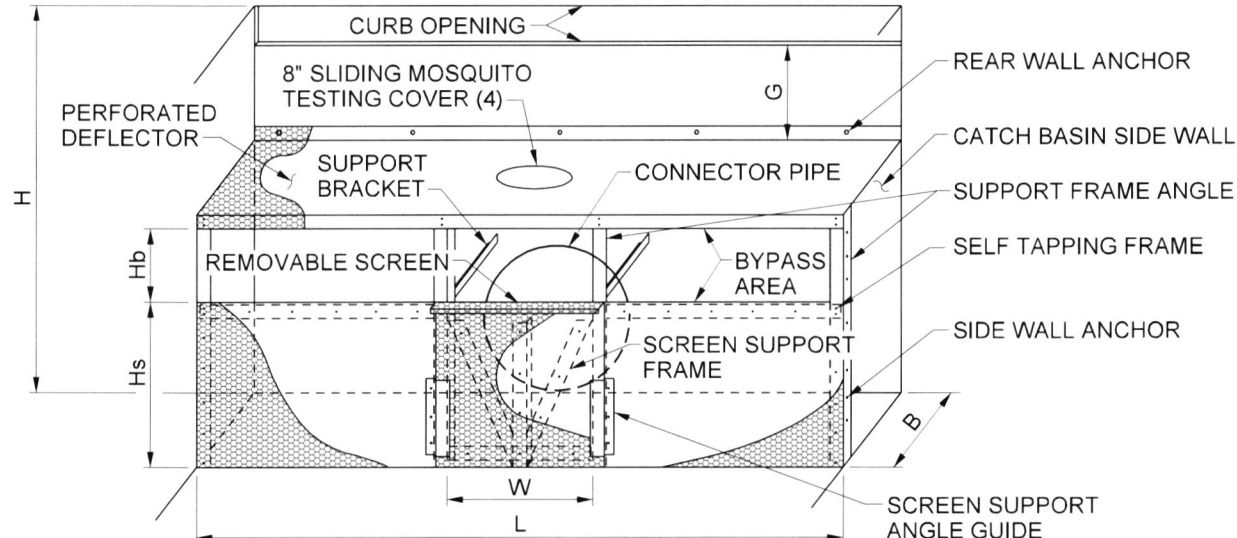

**TYPE B (SIDE WALL MOUNT)**

**DIMENSIONS:**

- SCREEN LENGTH (1) L
- REMOVABLE SCREEN WIDTH (2) W (24" TO 36")
- SCREEN HEIGHT (1) Hs
- SCREEN BYPASS HEIGHT (1) Hb
- MINIMUM WALL CLEARANCE (2) C = 12"
- MINIMUM INTERIOR SPACE (2) B = 10"
- DISTANCE BELOW GUTTER FL (1) G
- CATCH BASIN HEIGHT (5) H

**NOTES:**

1. SEE TABLES ON PAGES 10-13 FOR VALUES.
2. SEE FTCD GENERAL NOTES ON STANDARD 313-3.
3. SEE FTCD SCREEN TYPE AND LOCATIONS WITHIN CATCH BASINS ON STANDARD 313-4 TO 313-8.
4. MOSQUITO TESTING COVER REQUIRED ONLY FOR STANDARD No. 301 AND 302 APPLICATIONS.
5. CB HEIGHT IS VERTICAL DISTANCE FROM TOP OF CURB TO OUTLET PIPE FLOW LINE.

NOT TO SCALE

PREPARED UNDER THE SUPERVISION OF:

*Mark Lancaster*  
 DIRECTOR OF TRANSPORTATION DATE 11/30/22  
 MARK LANCASTER, P.E.



COUNTY OF RIVERSIDE  
**FULL TRASH CAPTURE  
 DEVICE (FTCD) -  
 CONNECTOR  
 PIPE SCREEN (CPS)**  
 STANDARD No. 313 (1 OF 14)

REVISION	DESCRIPTION	MARK	DATE	APPROVED



**FTCD SPECIFICATIONS**

1. FULL TRASH CAPTURE DEVICE (FTCD) SHALL BE A UNITED STORM WATER, INC. CONNECTOR PIPE SCREEN (CPS) OR EQUIVALENT. EQUIVALENT SYSTEMS OR ALTERNATIVE DESIGNS SHALL BE ON THE STATE OF CALIFORNIA APPROVED TRASH CAPTURE DEVICE LIST AND REQUIRE APPROVAL OF THE TRANSPORTATION DEPARTMENT.
2. FTCD SHALL HAVE STRUCTURAL FRAME FOR STIFFNESS AND TO ENABLE BOLTING TO CATCH BASIN FLOOR AND WALL. FRAME MEMBERS SHALL BE FABRICATED FROM PERFORATED 14 GAUGE GRADE 304 STAINLESS STEEL HAVING 5 MM DIAMETER HOLES.
3. FTCD SCREENS SHALL BE FABRICATED FROM PERFORATED 14 GAUGE GRADE 304 STAINLESS STEEL HAVING 5 MM DIAMETER HOLES.
4. FTCD SHALL HAVE A PERFORATED DEFLECTOR SCREEN COVERING THE TOP OF THE FTCD TO PROHIBIT DEBRIS FROM FALLING BEHIND THE FRONT AND SIDE SCREENS. THE DEFLECTOR SHALL BE ABLE TO WITHSTAND A VERTICAL LOAD OF 10 LBS PER SQUARE FOOT.
5. FTCD FRAME AND SCREEN SHALL HAVE SUFFICIENT STRUCTURAL INTEGRITY TO WITHSTAND THE FORCE OF STANDING WATER IN THE CATCH BASIN ASSUMING THE SCREEN IS 100% CLOGGED.
6. FTCD SHALL BE FASTENED TO THE CATCH BASIN WALLS AND FLOOR WITH ANCHOR BOLTS. ANCHOR BOLTS SHALL BE SS-304, 3/8" DIAMETER AND 3" LENGTH, AND SHALL BE EPOXY SET INTO CATCH BASIN CONCRETE. IF REINFORCEMENT STEEL IS ENCOUNTERED DURING INSTALLATION, RELOCATE THE ANCHOR HOLE AND FILL VACANT HOLE WITH EPOXY. EPOXY SHALL BE ON THE CURRENT APPROVED LIST OF CHEMICAL ADHESIVES FOR USE IN CALTRANS CONTRACTS. ANCHOR BOLT SPACING TO BE 12" O.C. EXCEPT WHERE FRAME LENGTH WOULD RESULT IN LESS THAN 3 BOLTS PER FRAME MEMBER. IN THIS CASE FASTEN FRAME TO CATCH BASIN WALL USING 3 ANCHOR BOLTS.
7. THE SCREEN SHALL BE SECURED TO THE SUPPORT FRAME, BRACKETS AND SIDE PANEL USING #12 x 0.5" SELF TAPPING SS-304 TECH SCREWS .
8. THE FTCD SHALL BE FABRICATED ON SITE TO BE FLUSH WITH THE INTERIOR SURFACES OF THE CATCH BASIN. THE MAXIMUM ALLOWABLE GAP BETWEEN THE FTCD AND THE CATCH BASIN SURFACES IS 5MM (0.197 INCHES).
9. FOR SCREEN SPANS (DIMENSION "A" FOR TYPE A OR DIMENSION "L" FOR TYPE B PER STANDARD 313-1) GREATER THAN 36" PROVIDE ADDITIONAL SUPPORT BRACKETS AND SUPPORT FRAME ANGLES AT 36" ON CENTER OR LESS. SEE STANDARD 313-1 TYPE B FOR TYPICAL SUPPORT BRACKET AND SUPPORT FRAME ANGLE CONFIGURATION.

NOT TO SCALE

PREPARED UNDER THE SUPERVISION OF:

*Mark Lancaster*

11/30/22  
DATE

DIRECTOR OF TRANSPORTATION  
MARK LANCASTER, P.E.



COUNTY OF RIVERSIDE

**FTCD - CPS  
SPECIFICATIONS**

**STANDARD No. 313 (2 OF 14)**

REVISION	DESCRIPTION	MARK	DATE	APPROVED

**FTCD GENERAL NOTES (NEW CONSTRUCTION)**

1. FTCD SHALL CONFORM TO THE CONFIGURATIONS SHOWN IN STANDARD 313-4 THROUGH 313-8 AND SHALL BE SIZED ACCORDING TO THE SIZING TABLES SHOWN IN STANDARD 313-10 THROUGH 313-13.
2. THE REMOVABLE SCREEN WIDTH (W) SHALL EQUAL THE CONNECTOR PIPE DIAMETER OR 24", WHICHEVER IS GREATER, BUT SHALL NOT EXCEED 36". WHERE DIMENSION "A" PER STANDARD 313-1 TYPE A (BACK WALL MOUNT) IS LESS THAN OR EQUAL TO 36", THE REMOVABLE SCREEN MAY EXTEND THE FULL WIDTH OF THE FTCD (W = A). IN THIS CASE SUPPORT BRACKETS AND THE ASSOCIATED SUPPORT FRAME ANGLES WILL BE OMITTED.
3. IF THE FTCD CANNOT PROVIDE A SIDE WALL CLEARANCE (C) OF 12", PROVIDE A SIDE WALL MOUNT. AN L-SHAPED FTCD WILL HAVE ONE SIDE WALL AND ONE BACK WALL MOUNT.
4. THE INTERIOR SPACE DIMENSION "B" PER DRAWING 313-1 TYPE A, SHALL BE AT LEAST 10" UNLESS OTHERWISE AUTHORIZED BY THE TRANSPORTATION DEPARTMENT.
5. POSITIVE DRAINAGE TO THE OUTLET PIPE IS REQUIRED FOR THE ENTIRE CATCH BASIN FLOOR.
6. THE CATCH BASIN SHALL INCLUDE MAINTENANCE GAUGE STENCILING ON THE INTERIOR WALL OPPOSITE THE FTCD THAT IDENTIFIES THE ACCUMULATED DEBRIS ELEVATION AT 40% AND 100% OF THE FTCD HEIGHT. SEE STANDARD 313-9 FOR STENCILING REQUIREMENTS.
7. TRANSPORTATION DEPARTMENT APPROVAL REQUIRED WHERE CONNECTOR PIPE SIZE > 42" DIAMETER.
8. CATCH BASINS (NEW OR EXISTING) WITH FOSSIL FILTERS (PER STANDARD 300A OR EQUIVALENT) SHALL REQUIRE SPECIAL CONSIDERATION FOR INCORPORATION OF THE FTCD. A MODIFIED FTCD DESIGN SHALL BE SUBMITTED TO THE TRANSPORTATION DEPARTMENT FOR REVIEW AND APPROVAL PRIOR TO FABRICATION.
9. ENGINEER MAY PREPARE SITE SPECIFIC CPS DESIGN UTILIZING THE CPS FLOW CHART PER STANDARD 313-14 IN LIEU OF SIZING PER STANDARD 313-10 THROUGH 313-13.

**FTCD RETROFIT NOTES**

10. WHERE MANHOLE CONFIGURATIONS IN THE EXISTING CATCH BASIN DO NOT CONFORM WITH FTCD LOCATIONS SHOWN IN STANDARD 313-4 THROUGH 313-8, NEW MANHOLES OPENINGS SHALL BE INSTALLED TO CONFORM WITH THESE REQUIREMENTS. RETROFIT DESIGN DRAWINGS MUST BE APPROVED BY THE TRANSPORTATION DEPARTMENT.
11. IF ADEQUATE SPACE IS NOT AVAILABLE FOR RETROFIT OF EXISTING CATCH BASIN WITH FTCD, A MODIFIED FTCD DESIGN SHALL BE SUBMITTED TO THE TRANSPORTATION DEPARTMENT FOR REVIEW AND APPROVAL PRIOR TO FABRICATION.
12. CATCH BASINS THAT DO NOT DRAIN TOWARD THE CONNECTOR PIPE SHALL BE MODIFIED TO DRAIN PROPERLY UTILIZING A POLYESTER POLYMER CONCRETE OVERLAY PRODUCT APPROVED BY THE TRANSPORTATION DEPARTMENT PRIOR TO INSTALLATION OF THE FTCD. THE BASIN FLOOR SHALL BE ROUGHENED TO THE SATISFACTION OF THE TRANSPORTATION DEPARTMENT PRIOR TO APPLICATION OF THE OVERLAY. SURFACE PREPARATION MUST PROVIDE FOR MINIMUM OVERLAY THICKNESS PER OVERLAY PRODUCT MANUFACTURER'S SPECIFICATIONS. PROPER DRAINAGE OF BASIN FLOOR SHALL BE ACHIEVED TO THE SATISFACTION OF THE TRANSPORTATION DEPARTMENT.

NOT TO SCALE

PREPARED UNDER THE SUPERVISION OF:

*Mark Lancaster* 11/30/22  
 DIRECTOR OF TRANSPORTATION DATE  
 MARK LANCASTER, P.E.

REVISION	DESCRIPTION	MARK	DATE	APPROVED

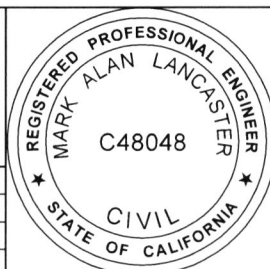

COUNTY OF RIVERSIDE

**FTCD - CPS  
 GENERAL NOTES AND  
 RETROFIT NOTES**

**STANDARD No. 313 (3 OF 14)**

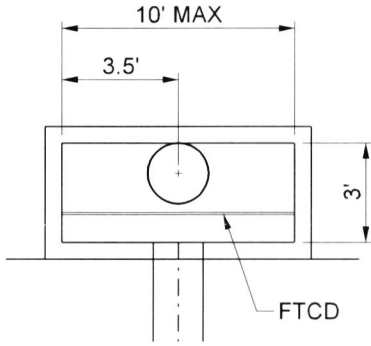

**CENTERED CP**

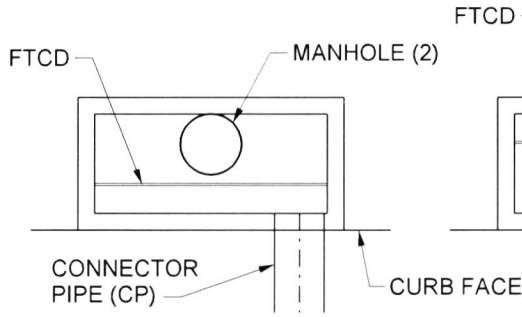

**OFFSET CP**

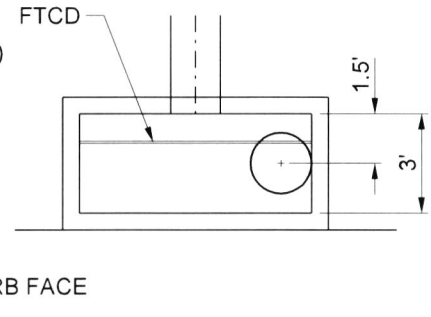

**BACK WALL CP**

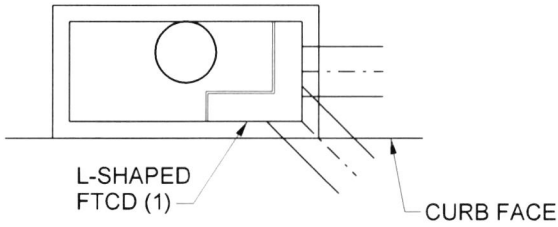

**SIDE OR CORNER CP (1)(3)**

**NOTES:**

- (1) FOR CORNER AND SIDE CONNECTOR PIPE (CP) LOCATIONS THE FTCD SHALL BE L-SHAPED TO FULLY COVER THE PIPE OPENING. A SUPPORT FRAME ANGLE SHALL BE PROVIDED IN THE CPS CORNER.
- (2) DETAIL VALID FOR CATCH BASIN WIDTHS LESS THAN OR EQUAL TO 10 FEET. MULTIPLE MANHOLES REQUIRED FOR CATCH BASIN WIDTHS GREATER THAN 10 FEET. SEE STANDARD NO. 313-5 AND 313-6.
- (3) FOR SIDE OR CORNER CP LOCATIONS WHERE REQUIRED SCREEN LENGTH (L) CANNOT BE ACHIEVED SPECIAL DESIGN MUST BE SUBMITTED TO THE TRANSPORTATION DEPARTMENT FOR REVIEW AND APPROVAL.

NOT TO SCALE

PREPARED UNDER THE SUPERVISION OF:

*Mark Lancaster*  
 DIRECTOR OF TRANSPORTATION  
 MARK LANCASTER, P.E.  
 11/30/22  
 DATE

REVISION	DESCRIPTION	MARK	DATE	APPROVED



COUNTY OF RIVERSIDE

**FTCD - CPS SCREEN /  
 MANHOLE LOCATIONS FOR  
 10' MAX WIDTH STANDARD NO. 300  
 CURB INLET CATCH BASINS**

**STANDARD No. 313 (4 OF 14)**

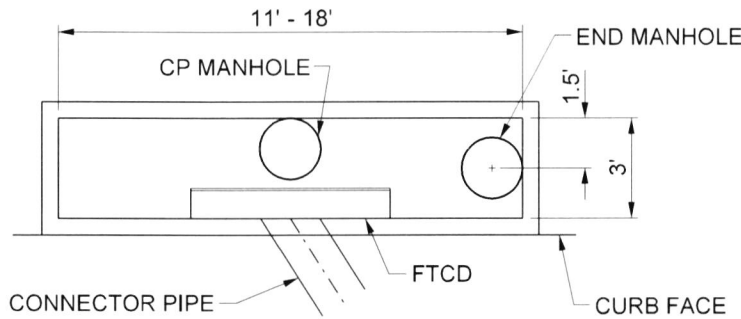

**CENTERED CONNECTOR PIPE (CP) (1)(2)**

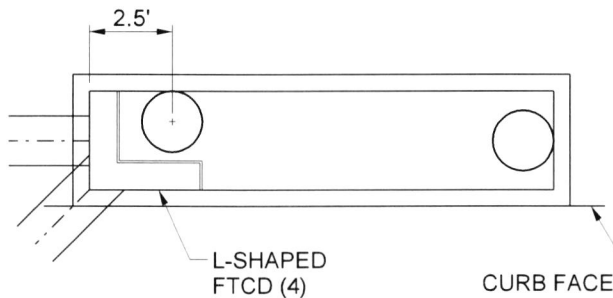

**SIDE OR CORNER CP (4)(5)**

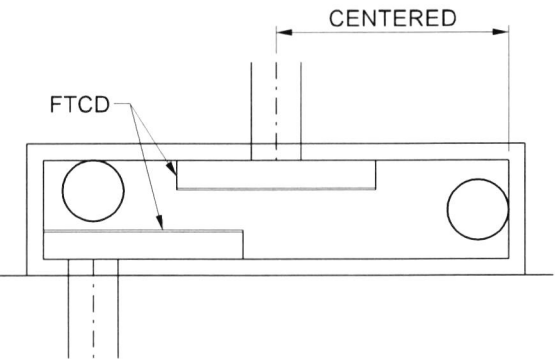

**OFFSET OR BACK WALL CP (1)(3)**

**NOTES:**

- (1) FOR CONNECTOR PIPE EXITING TOWARD STREET CENTERLINE, LOCATE CONNECTOR PIPE (CP) MANHOLE ALONG BACK WALL OPPOSITE OF CP CENTERLINE. LOCATE END MANHOLE AT EITHER END WHEN CP IS CENTERED IN CATCH BASIN, OR ON OPPOSITE SIDE OF CP WHEN CP IS ON EITHER SIDE OF CATCH BASIN CENTERLINE.
- (2) SHALLOW CATCH BASINS WITH A HEIGHT (H) LESS THAN 3.5' SHALL INCLUDE A THIRD MANHOLE ON THE OPPOSITE SIDE OF THE CONNECTOR PIPE FROM THAT SHOWN PLACED AGAINST THE END WALL.
- (3) CONNECTOR PIPE EXITING THROUGH BACK WALL OF CATCH BASIN MUST BE CENTERED IN CATCH BASIN UNLESS APPROVED BY THE TRANSPORTATION DEPARTMENT.
- (4) FOR CORNER AND SIDE CONNECTOR PIPE (CP) LOCATIONS, THE FTCD SHALL BE L-SHAPED TO FULLY COVER THE PIPE OPENING. A SUPPORT FRAME ANGLE SHALL BE PROVIDED IN THE CPS CORNER.
- (5) FOR SIDE OR CORNER CP LOCATIONS WHERE REQUIRED SCREEN LENGTH (L) CANNOT BE ACHIEVED, SPECIAL DESIGN MUST BE SUBMITTED TO THE TRANSPORTATION DEPARTMENT FOR REVIEW AND APPROVAL.

NOT TO SCALE

PREPARED UNDER THE SUPERVISION OF:

*Mark Lancaster* 11/30/22  
 DIRECTOR OF TRANSPORTATION DATE  
 MARK LANCASTER, P.E.

REVISION	DESCRIPTION	MARK	DATE	APPROVED



COUNTY OF RIVERSIDE

**FTCD - CPS SCREEN /  
 MANHOLE LOCATIONS FOR  
 11'-18' WIDTH STANDARD NO. 300  
 CURB INLET CATCH BASINS**

**STANDARD No. 313 (5 OF 14)**

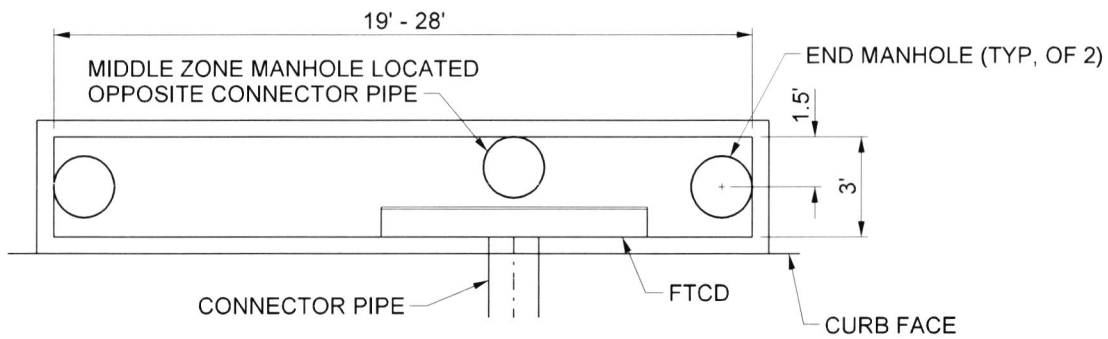

**CENTERED OR MIDDLE ZONE CP (1)**

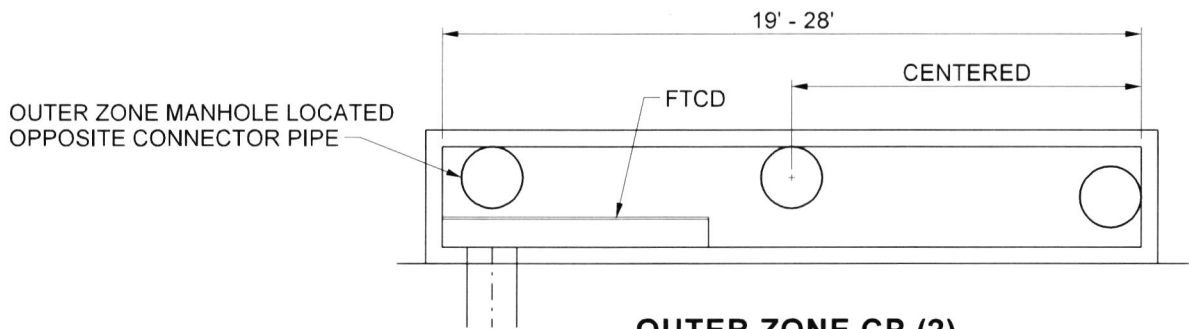

**OUTER ZONE CP (2)**

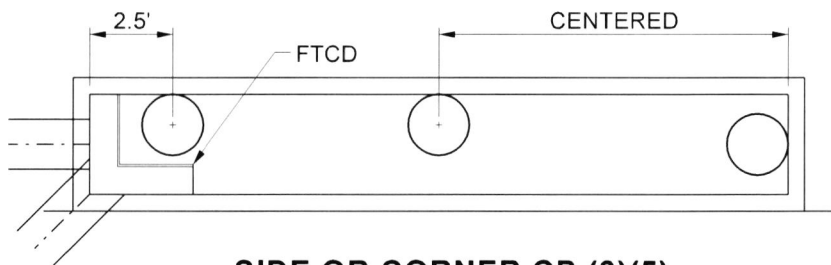

**SIDE OR CORNER CP (3)(5)**

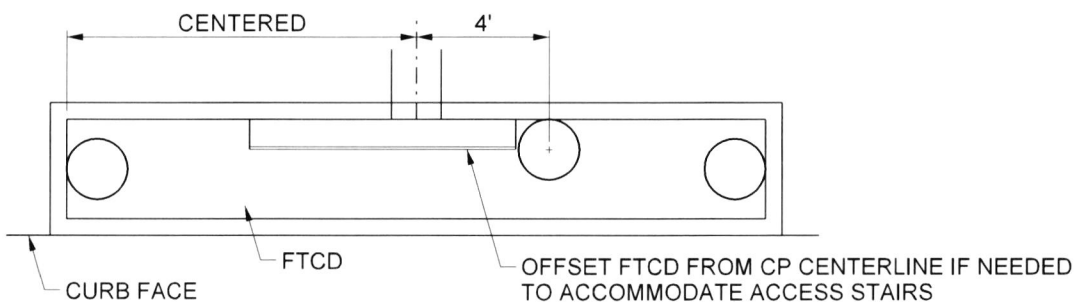

**BACK WALL CP (4)**

**NOTE:**  
SEE STANDARD NO. 313-7  
FOR REFERENCED NOTES.

NOT TO SCALE

PREPARED UNDER THE SUPERVISION OF:

*Mark Lancaster*  
DIRECTOR OF TRANSPORTATION  
MARK LANCASTER, P.E.      11/30/22  
DATE

REVISION	DESCRIPTION	MARK	DATE	APPROVED



COUNTY OF RIVERSIDE

**FTCD - CPS SCREEN /  
MANHOLE LOCATIONS FOR  
19'-28' WIDTH STANDARD NO. 300  
CURB INLET CATCH BASINS**

**STANDARD No. 313 (6 OF 14)**

**NOTES: (FOR STANDARD NO. 313-6)**

- (1) FOR CONNECTOR PIPE EXITING TOWARD STREET CENTERLINE IN MIDDLE ZONE, LOCATE CONNECTOR PIPE (CP) MANHOLE ALONG BACK WALL OPPOSITE OF CP CENTERLINE. LOCATE END MANHOLES AT EITHER END OF CATCH BASIN AS SHOWN.
- (2) FOR CONNECTOR PIPE EXITING TOWARD STREET CENTERLINE IN OUTER ZONE, LOCATE OUTER ZONE MANHOLE ALONG BACK WALL OPPOSITE OF CP CENTERLINE. LOCATE ONE END MANHOLE ON THE OPPOSITE SIDE OF THE CB CENTERLINE FROM THE CP, AND ONE CENTERED MANHOLE ALONG THE CATCH BASIN BACK WALL.
- (3) FOR CORNER AND SIDE CONNECTOR PIPE (CP) LOCATIONS THE FTCD SHALL BE L-SHAPED TO FULLY COVER THE PIPE OPENING. A SUPPORT FRAME ANGLE SHALL BE PROVIDED IN THE CPS CORNER.
- (4) CONNECTOR PIPE EXITING THROUGH BACK WALL OF CATCH BASIN MUST BE CENTERED IN CATCH BASIN UNLESS APPROVED BY THE TRANSPORTATION DEPARTMENT.
- (5) FOR SIDE OR CORNER CP LOCATIONS WHERE REQUIRED SCREEN LENGTH (L) CANNOT BE ACHIEVED SPECIAL DESIGN MUST BE SUBMITTED TO THE TRANSPORTATION DEPARTMENT FOR REVIEW AND APPROVAL.

NOT TO SCALE

PREPARED UNDER THE SUPERVISION OF:

*Mark Lancaster* 11/30/22  
 DIRECTOR OF TRANSPORTATION DATE  
 MARK LANCASTER, P.E.



COUNTY OF RIVERSIDE

**FTCD - CPS SCREEN /  
 MANHOLE LOCATIONS FOR  
 19'-28' WIDTH STANDARD NO. 300  
 CURB INLET CATCH BASINS**

**STANDARD No. 313 (7 OF 14)**

REVISION	DESCRIPTION	MARK	DATE	APPROVED

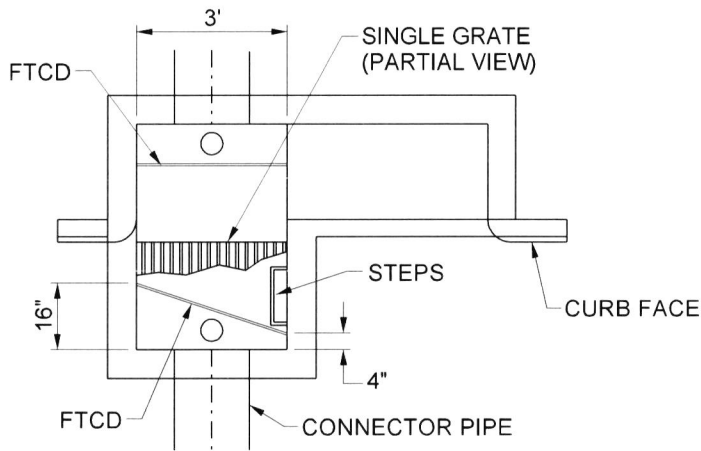

**CENTERED OR BACK WALL CP (1)(5)**

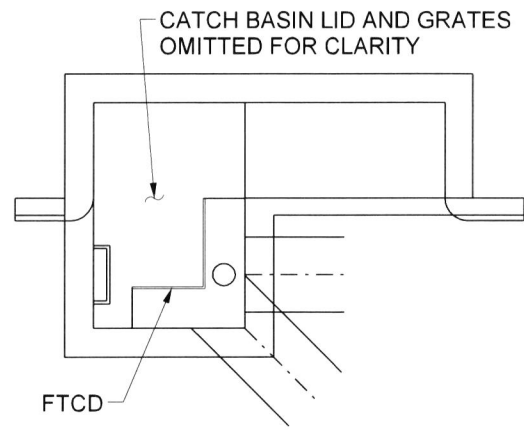

**SIDE OR CORNER CP (2)(4)**

**CATCH BASIN 301**

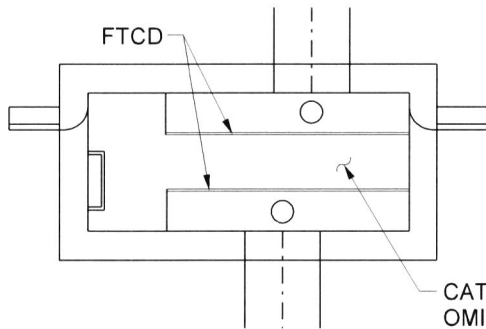

**CENTERED OR BACK WALL CP (3)(5)**

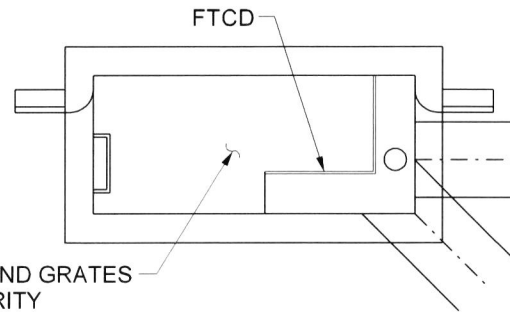

**SIDE OR CORNER CP (2)(3)(4)**

**CATCH BASIN 302**

**NOTES:**

- (1) WHEN STEPS OBSTRUCT THE STANDARD FTCD INSTALLATION, ANGLE THE SCREEN IN FRONT OF THE CONNECTOR PIPE TO AVOID THE STEPS AS SHOWN.
- (2) FOR CORNER AND SIDE CONNECTOR PIPE (CP) LOCATIONS, THE FTCD SHALL BE L-SHAPED TO FULLY COVER THE PIPE OPENING.
- (3) MULTIPLE GRATE CATCH BASIN WIDTH SHOWN. FOR SINGLE GRATE APPLICATIONS PLACE FTCD PER CATCH BASIN 301 DETAILS ABOVE.
- (4) FOR SIDE OR CORNER CP LOCATIONS WHERE REQUIRED SCREEN LENGTH (L) CANNOT BE ACHIEVED, SPECIAL DESIGN MUST BE SUBMITTED TO THE TRANSPORTATION DEPARTMENT FOR REVIEW AND APPROVAL.
- (5) INSTALL FTCD, TYPE B (SIDE WALL MOUNT), TO AVOID STEPS AS NECESSARY.

NOT TO SCALE

PREPARED UNDER THE SUPERVISION OF:

*Mark Lancaster*  
 DIRECTOR OF TRANSPORTATION  
 MARK LANCASTER, P.E.  
 11/30/22  
 DATE

REVISION	DESCRIPTION	MARK	DATE	APPROVED



COUNTY OF RIVERSIDE

**FTCD - CPS SCREEN  
 LOCATIONS FOR STANDARD NO.  
 CB301 AND CB302 COMBINATION  
 INLET CATCH BASINS**

**STANDARD No. 313 (8 OF 14)**

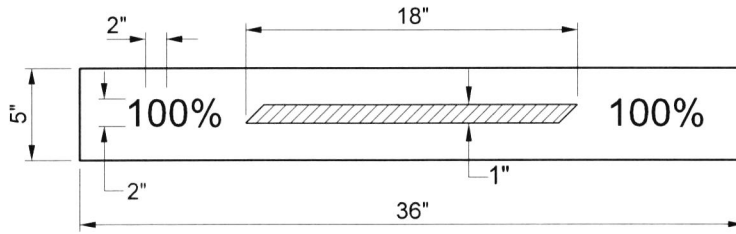

**100% STRIPE**

(RED STRIPES AND NUMBERS ON WHITE BACKGROUND)

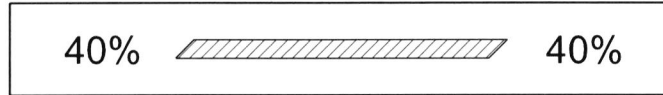

**40% STRIPE**

(RED STRIPES AND NUMBERS ON WHITE BACKGROUND)

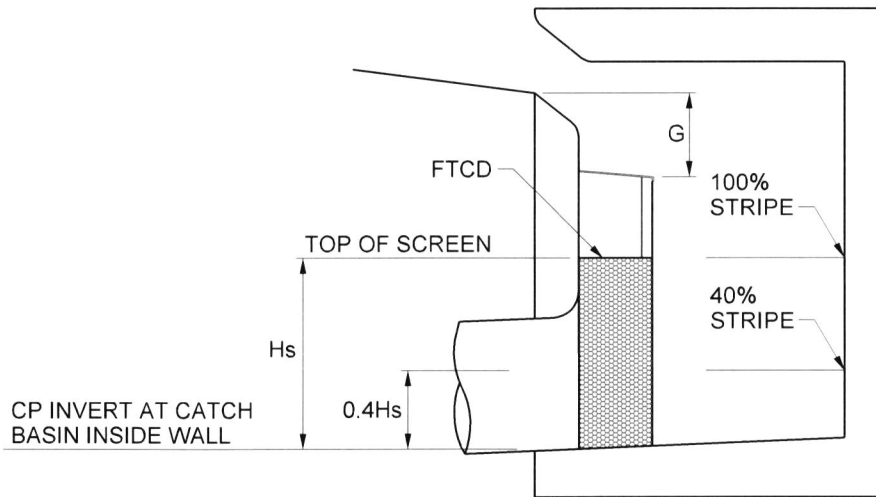

**NOTES:**

1. PAINT SHALL BE RED STRIPES AND NUMBERS ON WHITE BACKGROUND ON THE BACK WALL OF THE CATCH BASIN, LABELING 40% AND 100% SCREEN HEIGHT AS SHOWN ABOVE. PAINT SHALL BE WATERBORNE ACRYLIC AND REFLECTIVE.
2. SURFACES SHALL BE CLEAN, DRY AND FREE FROM ALL CONTAMINANTS PRIOR TO PAINTING.
3. STENCILING SHALL BE VISIBLE FROM THE STREET THROUGH CATCH BASIN OPENING.

NOT TO SCALE

PREPARED UNDER THE SUPERVISION OF:

*Mark Lancaster*  
 DIRECTOR OF TRANSPORTATION  
 MARK LANCASTER, P.E.  
 11/30/22  
 DATE



COUNTY OF RIVERSIDE

**FTCD - CPS  
 MAINTENANCE GAUGE**

**STANDARD No. 313 (9 OF 14)**

REVISION	DESCRIPTION	MARK	DATE	APPROVED



**FTCD SIZING TABLE FOR STANDARD NO. 300 CURB INLET CATCH BASIN  
ON GRADE CONDITION**

CATCH BASIN TYPE	H (FT)	CATCH BASIN WIDTH (FT) (1)	NUMBER OF GRATES	BYPASS HEIGHT H <sub>b</sub> (IN)	SCREEN HEIGHT H <sub>s</sub> (IN)	SCREEN LENGTH L (FT)	G (IN)	
300	2.5 (30 inches)	7.0	-	8.0	8.0	7.0	4.0	
		10.0				7.0		
		14.0				10.0		
	2.67 (32 inches)	7.0	-	8.0	10.0	7.0	4.0	
		10.0				7.0		
		14.0				10.0		
	2.83 (34 inches)	7.0	-	8.0	12.0	7.0	4.0	
		10.0				7.0		
		14.0				10.0		
		21.0				11.0		
	3.0	7.0	-	8.0	12.0	4.0	6.0	
		10.0				6.0		
		14.0		8.0	14.0	10.0	4.0	
		21.0				14.0		
		28.0				18.0		
	3.5	7.0	-	8.0	18.0	4.0	6.0	
		10.0				6.0		
		14.0		10.0	16.0	6.0		6.0
		21.0				7.0		
		28.0				9.0		
	4.0	7.0	-	12.0	20.0	4.0	6.0	
		10.0				6.0		
		14.0				6.0		
		21.0				7.0		
4.5 OR GREATER	7.0	-	12.0	24.0	4.0	8.0		
	10.0				6.0			
	14.0				6.0			
	21.0				7.0			
	28.0				8.0			

**NOTES:**

- FOR CATCH BASIN WIDTHS NOT SHOWN USE NEXT HIGHER VALUE.
- WHERE THE SCREEN LENGTH (L) IS EQUAL TO THE CATCH BASIN WIDTH, THE CPS SHALL BE THE FULL WIDTH OF THE CATCH BASIN AND UTILIZE A SIDE WALL MOUNT.

NOT TO SCALE

PREPARED UNDER THE SUPERVISION OF:

*Mark Lancaster*  
 DIRECTOR OF TRANSPORTATION  
 MARK LANCASTER, P.E.  
 11/30/22  
 DATE



COUNTY OF RIVERSIDE

**FTCD - CPS SIZING TABLE  
FOR STANDARD NO. 300 CURB  
INLET CATCH BASIN  
ON GRADE CONDITION**

**STANDARD No. 313 (10 OF 14)**

REVISION	DESCRIPTION	MARK	DATE	APPROVED

**FTCD SIZING TABLE FOR STANDARD NO. 301 AND 302 COMBINATION  
INLET CATCH BASIN ON GRADE CONDITION**

CATCH BASIN TYPE	H (FT)	CATCH BASIN WIDTH (FT) (1)	NUMBER OF GRATES	BYPASS HEIGHT H <sub>b</sub> (IN)	SCREEN HEIGHT H <sub>s</sub> (IN)	SCREEN LENGTH L (FT)	G (IN)
301	3.0	7.0	1	8.0	10.0	4.0	10.0
		10.0	2			7.0	
		14.0	1			8.0	
		14.0	2			8.0	
	3.5	7.0	1	10.0	12.0	6.0	12.0
		10.0	2			5.0	
		14.0	1			5.0	
		14.0	2			6.0	
	4.0	7.0	1	12.0	15.0	4.0	13.0
		10.0	2			5.0	
		14.0	1			4.0	
		14.0	2			5.0	
	4.5 OR GREATER	7.0	1	12.0	18.0	4.0	16.0
		10.0	2			5.0	
		14.0	1			4.0	
		14.0	2			5.0	
302	3.0	-	1	9.0	9.0	3.0	10.0
		-	2			5.0	
		-	3			6.0	
	3.5	-	1	10.0	12.0	2.5	12.0
		-	2			4.0	
		-	3			5.0	
	4.0 OR GREATER	-	1	10.0	18.0	2.5	12.0
		-	2			4.0	
		-	3			5.0	

**NOTES:**

- FOR CATCH BASIN WIDTHS NOT SHOWN USE NEXT HIGHER VALUE.

NOT TO SCALE

PREPARED UNDER THE SUPERVISION OF:

*Mark Lancaster* 11/30/22  
 DIRECTOR OF TRANSPORTATION DATE  
 MARK LANCASTER, P.E.



COUNTY OF RIVERSIDE

**FTCD - CPS SIZING TABLE  
FOR STANDARD NO. 301 AND 302  
COMBINATION INLET  
CATCH BASIN  
ON GRADE CONDITION**

**STANDARD No. 313 (11 OF 14)**

REVISION	DESCRIPTION	MARK	DATE	APPROVED

**FTCD SIZING TABLE FOR STANDARD NO. 300 CURB INLET CATCH BASIN  
SUMP CONDITION**

CATCH BASIN TYPE	H (FT)	CATCH BASIN WIDTH (FT) (1)	NUMBER OF GRATES	BYPASS HEIGHT H <sub>b</sub> (IN)	SCREEN HEIGHT H <sub>s</sub> (IN)	SCREEN LENGTH L (FT)	G (IN)
300	3.5	7.0	-	12.0	16.0	7.0	4.0
		10.0		14.0	14.0	6.0	
		14.0			7.0		
	4.0	7.0	-	16.0	18.0	7.0	4.0
		10.0				6.0	
		14.0		18.0	16.0	6.0	
		21.0				7.0	
	28.0	8.0					
	4.5	7.0	-	16.0	18.0	7.0	10.0
		10.0				6.0	
		14.0		18.0	16.0	6.0	
		21.0				7.0	
		28.0				8.0	
	5.0 OR GREATER	7.0	-	16.0	24.0	7.0	10.0
		10.0				6.0	
		14.0		18.0	20.0	6.0	
21.0		7.0					
28.0		8.0					

**NOTES:**

- FOR CATCH BASIN WIDTHS NOT SHOWN USE NEXT HIGHER VALUE.

NOT TO SCALE

PREPARED UNDER THE SUPERVISION OF:

*Mark Lancaster*  
 DIRECTOR OF TRANSPORTATION  
 MARK LANCASTER, P.E.  
 11/30/22  
 DATE



COUNTY OF RIVERSIDE

**FTCD - CPS SIZING TABLE  
 FOR STANDARD NO. 300  
 CURB INLET CATCH BASIN  
 SUMP CONDITION**

**STANDARD No. 313 (12 OF 14)**

REVISION	DESCRIPTION	MARK	DATE	APPROVED



**FTCD SIZING TABLE FOR STANDARD NO. 301 AND 302 COMBINATION  
INLET CATCH BASIN SUMP CONDITION**

CATCH BASIN TYPE	H (FT)	CATCH BASIN WIDTH (FT) (1)	NUMBER OF GRATES	BYPASS HEIGHT H <sub>b</sub> (IN)	SCREEN HEIGHT H <sub>s</sub> (IN)	SCREEN LENGTH L (FT)	G (IN)
301	3.5	7.0	1	14.0	9.0	7.0	11.0
	4.0	7.0	1	16.0	11.0	5.0	13.0
		10.0	2			6.0	
	4.5	7.0	1	18.0	15.0	5.0	13.0
		10.0	2			6.0	
		14.0	1			5.0	
		14.0	2			6.0	
	5.0 OR GREATER	7.0	1	18.0	18.0	4.0	16.0
		10.0	2			6.0	
		14.0	1			5.0	
		14.0	2			6.0	
	302	4.0	-	2	14.0	8.0	2.5
-			3	6.0			
4.5		-	1	16.0	8.0	2.5	22.0
		-	2	16.0	10.0	5.0	20.0
		-	3			7.0	
5.0 OR GREATER		-	1	16.0	12.0	2.5	24.0
		-	2			5.0	
		-	3			7.0	

**NOTES:**

- FOR CATCH BASIN WIDTHS NOT SHOWN USE NEXT HIGHER VALUE.

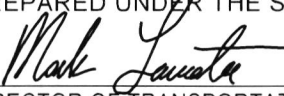
NOT TO SCALE

PREPARED UNDER THE SUPERVISION OF:  DIRECTOR OF TRANSPORTATION MARK LANCASTER, P.E.					COUNTY OF RIVERSIDE <b>FTCD - CPS SIZING TABLE FOR STANDARD NO. 301 AND 302 COMBINATION INLET CATCH BASIN SUMP CONDITION</b>	
REVISION DESCRIPTION		MARK	DATE		APPROVED	<b>STANDARD No. 313 (13 OF 14)</b>

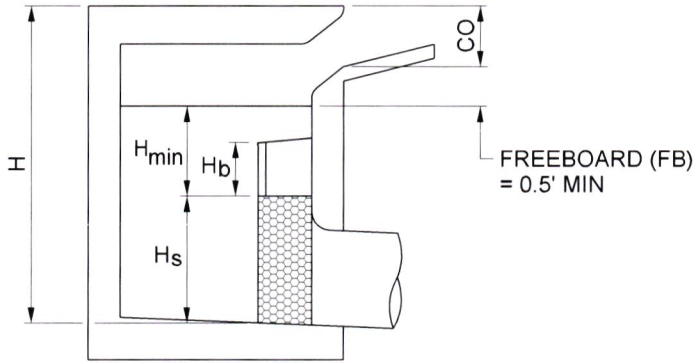

**NOTE:**  
THE BELOW ANALYSIS ASSUMES THAT THE CONNECTOR PIPE SCREEN IS COMPLETELY CLOGGED AND ALL FLOW IS CONVEYED THROUGH THE BYPASS

VALUE	UNITS	DESCRIPTION
H	FT	HEIGHT OF CATCH BASIN, AS DEFINED IN STANDARDS NO. 300, 301 AND 302
H <sub>min</sub>	FT	DEPTH FROM TOP OF SCREEN TO FREEBOARD
H <sub>b</sub>	IN	BYPASS OPENING HEIGHT
H <sub>s</sub>	IN	SCREEN HEIGHT
L	FT	BYPASS OPENING LENGTH
FREE-BOARD (FB)	FT	MINIMUM ALLOWABLE FREEBOARD (FB) IS 0.5' TO ENSURE THAT WATER LEVELS INSIDE THE CATCH BASIN DO NOT IMPAIR THE CATCH BASIN STREET INTERCEPTION CAPACITY
CO	IN	CURB OPENING HEIGHT (CO) IS DEFINED HERE AS THE HEIGHT FROM THE TOP OF CURB TO THE FLOW LINE OF THE INLET AT THE LOCAL DEPRESSION
Q <sub>i</sub>	CFS	FLOW RATE INTERCEPTED BY THE INLET AS DETERMINED BY THE ENGINEER FOR SITE-SPECIFIC CONDITIONS
Q <sub>o</sub>	CFS	BYPASS FLOW RATE UNDER ORIFICE FLOW CONDITION, ASSUMES THAT ENTIRE BYPASS OPENING FUNCTIONS AS A RECTANGULAR ORIFICE
Q <sub>w</sub>	CFS	BYPASS FLOW RATE UNDER WEIR FLOW CONDITION
C <sub>o</sub>	-	ORIFICE FLOW COEFFICIENT = 0.61
C <sub>w</sub>	-	WEIR FLOW COEFFICIENT = 0.61
A <sub>o</sub>	FT <sup>2</sup>	BYPASS OPENING AREA FOR ORIFICE FLOW, ASSUMES THAT THE ENTIRE BYPASS OPENING FUNCTIONS AS A RECTANGULAR ORIFICE

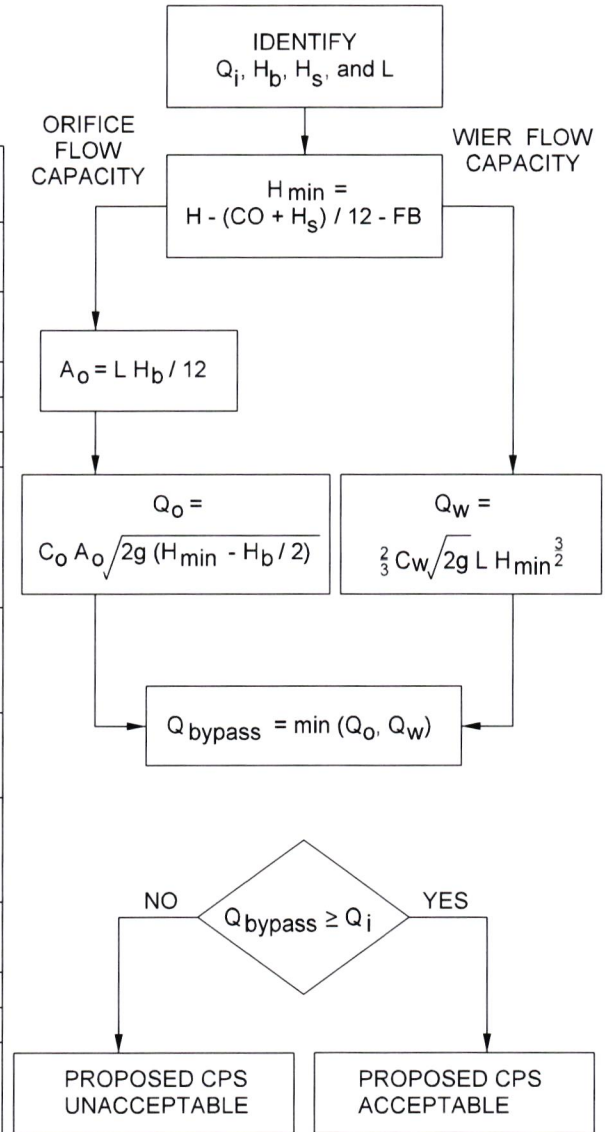

NOT TO SCALE

PREPARED UNDER THE SUPERVISION OF:

*Mark Lancaster* 11/30/22  
 DIRECTOR OF TRANSPORTATION DATE  
 MARK LANCASTER, P.E.

REVISION	DESCRIPTION	MARK	DATE	APPROVED



COUNTY OF RIVERSIDE

**FTCD - CPS  
BYPASS CHECK  
FLOW CHART**

**STANDARD No. 313 (14 OF 14)**

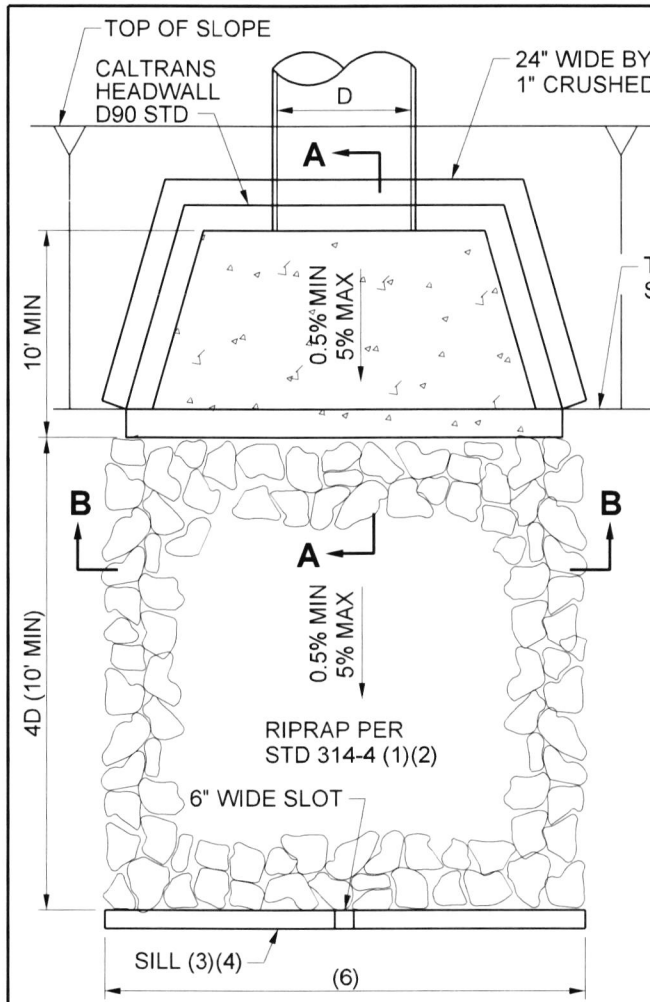

**PLAN**

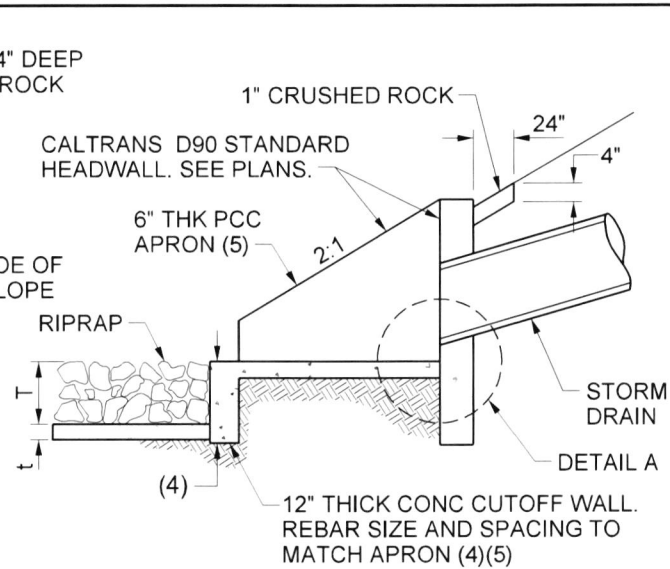

**SECTION "A-A"**

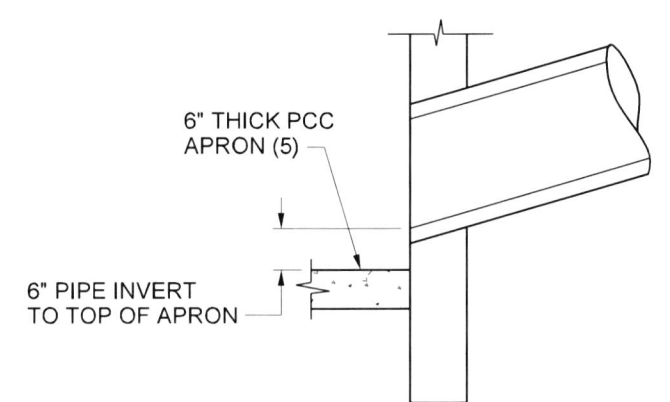

**DETAIL A**

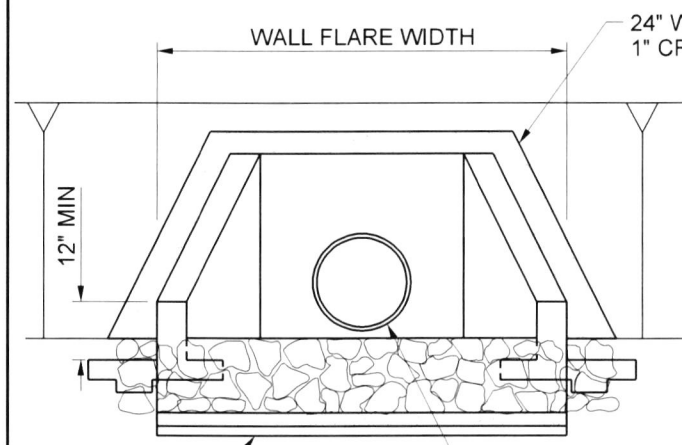

**SECTION "B-B"**

**NOTES:**

1. PLANS SHALL SPECIFY FOR THIS STANDARD:  
(A) RIPRAP CLASS AND THICKNESS (T)  
(B) FILTER BLANKET MATERIAL AND THICKNESS (t).
2. ADDITIONAL RIPRAP MAY BE NECESSARY FOR STEEP APPLICATIONS (> 5%).
3. ADD 12" THICK CONCRETE SILL WHEN D>36", OR WHEN REQUIRED BY THE ENGINEER - SEE STD 314-4.
4. CUTOFF WALL AND SILL DEPTH TO BE 4" OR RIPRAP THICKNESS (T) PLUS FILTER THICKNESS (t) WHICHEVER IS GREATER.
5. 10' LONG (MIN) BY 6" THICK CONCRETE APRON WITH #4 BARS AT 18" OC.
6. RIPRAP PAD WIDTH TO BE THE GREATER OF THE WALL FLARE WIDTH OR 10'.

NOT TO SCALE

PREPARED UNDER THE SUPERVISION OF:

*Mark Lancaster* 11/30/22  
 DIRECTOR OF TRANSPORTATION DATE  
 MARK LANCASTER, P.E.

REVISION	DESCRIPTION	MARK	DATE	APPROVED



COUNTY OF RIVERSIDE  
**RIPRAP ENERGY DISSIPATOR AND APRON AT WINGWALL STORM DRAIN OUTFALL**  
 STANDARD No. 314 (1 OF 4)

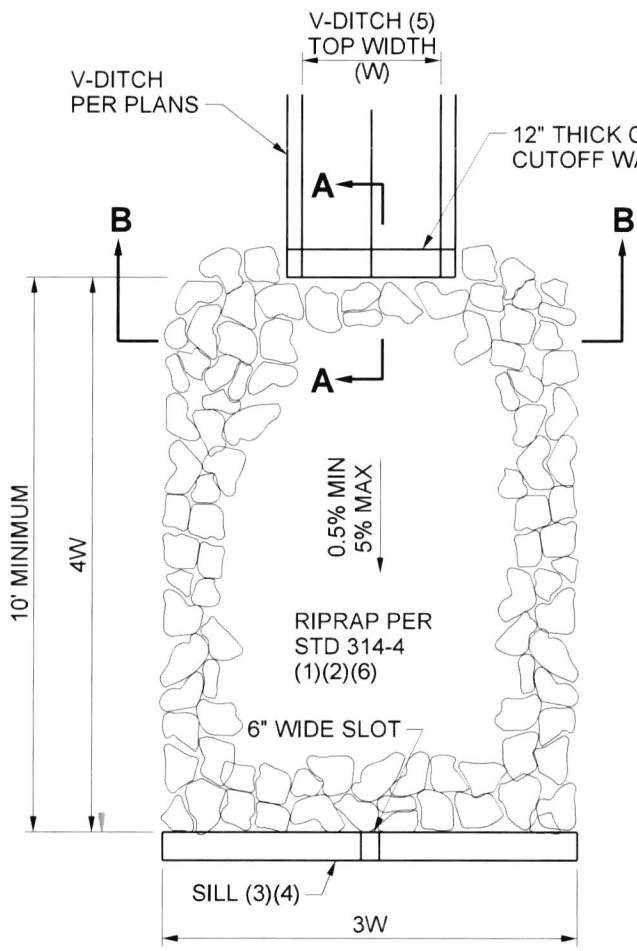

**PLAN**

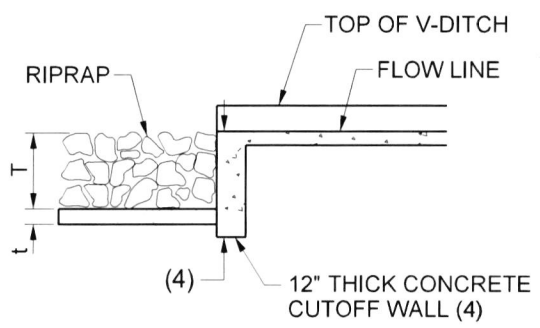

**SECTION "A-A"**

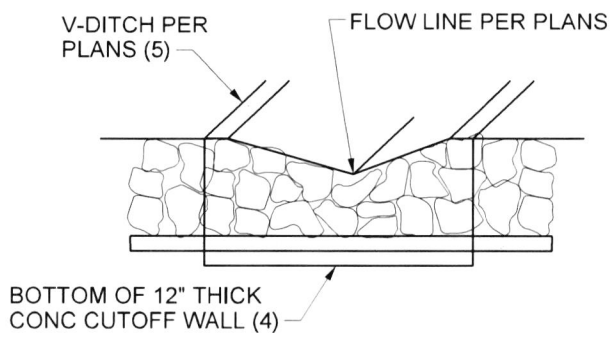

**SECTION "B-B"**

**NOTES:**

1. PLANS SHALL SPECIFY FOR THIS STANDARD:  
(A) RIPRAP CLASS AND THICKNESS (T)  
(B) FILTER BLANKET MATERIAL AND THICKNESS (t).
2. ADDITIONAL RIPRAP MAY BE NECESSARY FOR STEEP APPLICATIONS (> 5%).
3. ADD 12" THICK CONCRETE SILL WHEN  $W > 36"$ , OR WHEN REQUIRED BY THE ENGINEER - SEE STD 314-4.
4. CUTOFF WALL AND SILL DEPTH TO BE 4' OR RIPRAP THICKNESS (T) PLUS FILTER THICKNESS (t) WHICHEVER IS GREATER.
5. DETAIL MAY BE UTILIZED FOR CIRCULAR CONCRETE DITCH ALSO.
6. FOR 3' WIDE DITCH AT SLOPE OF  $< 5\%$  AND A FLOW RATE  $< 3.0$  CFS, ENERGY DISSIPATOR MAY BE 6' BY 6' No. 2 BACKING PER STD 314-4.

NOT TO SCALE

PREPARED UNDER THE SUPERVISION OF:

*Mark Lancaster*

11/30/22  
DATE

DIRECTOR OF TRANSPORTATION  
MARK LANCASTER, P.E.



COUNTY OF RIVERSIDE

**RIPRAP ENERGY DISSIPATOR AT V-DITCH OUTFALL**

**STANDARD No. 314 (2 OF 4)**

REVISION	DESCRIPTION	MARK	DATE	APPROVED

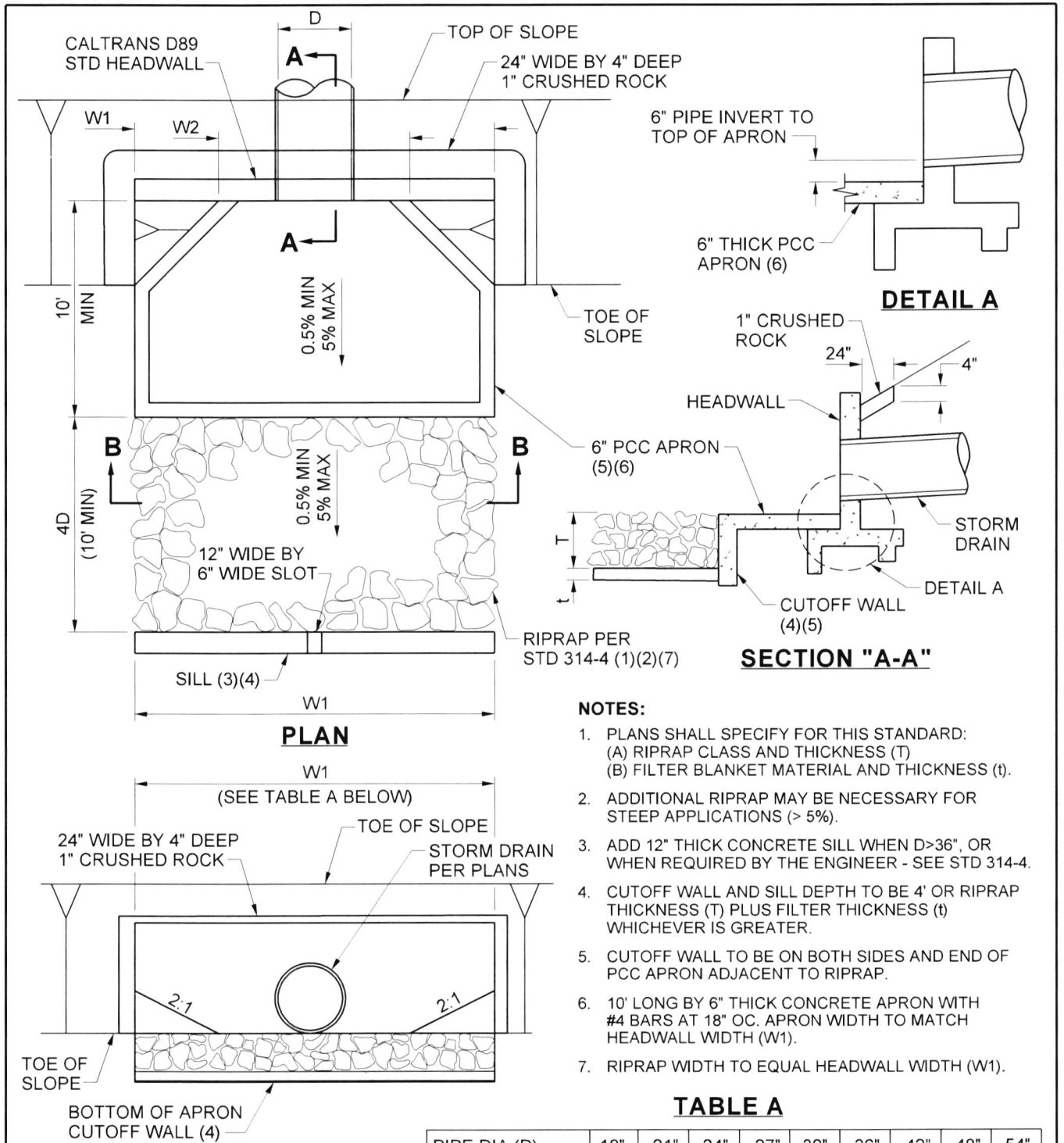

**NOTES:**

1. PLANS SHALL SPECIFY FOR THIS STANDARD:  
(A) RIPRAP CLASS AND THICKNESS (T)  
(B) FILTER BLANKET MATERIAL AND THICKNESS (t).
2. ADDITIONAL RIPRAP MAY BE NECESSARY FOR STEEP APPLICATIONS (> 5%).
3. ADD 12" THICK CONCRETE SILL WHEN D>36", OR WHEN REQUIRED BY THE ENGINEER - SEE STD 314-4.
4. CUTOFF WALL AND SILL DEPTH TO BE 4' OR RIPRAP THICKNESS (T) PLUS FILTER THICKNESS (t) WHICHEVER IS GREATER.
5. CUTOFF WALL TO BE ON BOTH SIDES AND END OF PCC APRON ADJACENT TO RIPRAP.
6. 10' LONG BY 6" THICK CONCRETE APRON WITH #4 BARS AT 18" OC. APRON WIDTH TO MATCH HEADWALL WIDTH (W1).
7. RIPRAP WIDTH TO EQUAL HEADWALL WIDTH (W1).

**TABLE A**

PIPE DIA (D)	18"	21"	24"	27"	30"	36"	42"	48"	54"
WALL WIDTH (W1)	12.7'	13.7'	14.7'	15.7'	16.7'	18.7'	20.7'	22.7'	25.2'
APRON WIDTH (W2)	4.0'	4.0'	4.0'	4.0'	4.0'	4.0'	4.0'	4.0'	4.5'

NOT TO SCALE

PREPARED UNDER THE SUPERVISION OF:

*Mark Lancaster*  
 DIRECTOR OF TRANSPORTATION  
 MARK LANCASTER, P.E.  
 11/30/22  
 DATE

REVISION	DESCRIPTION	MARK	DATE	APPROVED



COUNTY OF RIVERSIDE

**RIPRAP ENERGY DISSIPATOR  
 AND APRON AT STRAIGHT  
 HEADWALL OUTFALL**

**STANDARD No. 314 (3 OF 4)**



### RIPRAP ENERGY DISSIPATER SIZING TABLE

DESIGN VELOCITY (FT/SEC)	RIPRAP CLASS	RIPRAP THICKNESS (T) PLACEMENT METHOD A *	RIPRAP THICKNESS (T) PLACEMENT METHOD B *	FILTER MATERIAL **	FILTER THICKNESS (t)
6-8	NO. 2 BACKING	N/A	1.25'	1" CRUSHED ROCK	0.5'
8-13	1/4 TON	N/A	3.3'	1" CRUSHED ROCK	0.75'
13-15	1/2 TON	3.4'	4.3'	1" CRUSHED ROCK	1.0'
15-17	1 TON	4.3'	5.4'	1" CRUSHED ROCK	1.0'
17-20	2 TON	5.4'	N/A	1" CRUSHED ROCK	1.0'

\* FOR RIPRAP GRADATION AND PLACEMENT METHOD DESCRIPTIONS SEE CALTRANS STD SPECIFICATIONS SECTION 72-2

\*\* SEE 1" CRUSHED ROCK GRADATION THIS SHEET

#### 1" CRUSHED ROCK GRADATION

SIEVE SIZE	PERCENT (%) PASSING
1-1/2" (37.5 mm)	100
1" (25.0 mm)	90-100
3/4" (19.0 mm)	30-60
1/2" (12.5 mm)	0-20
3/8" (9.5 mm)	-
No. 4 (4.75 mm)	0-5
No. 8 (2.36 mm)	-
ASTM C131 Testing Grading	A

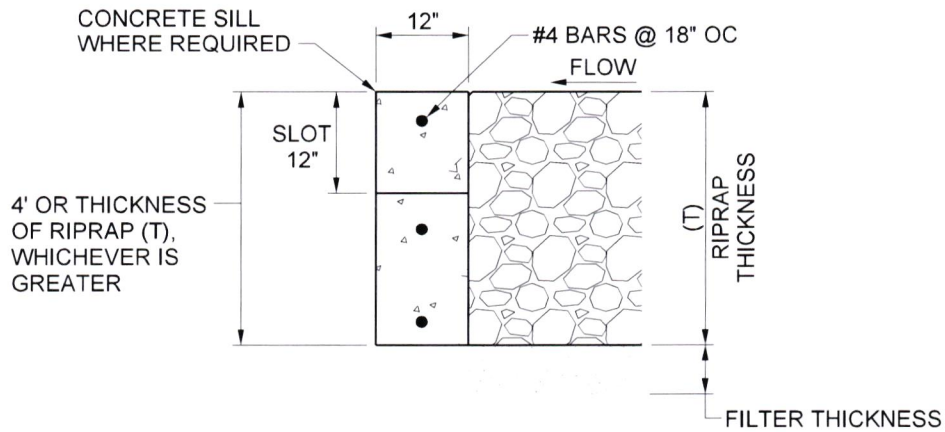

NOT TO SCALE

PREPARED UNDER THE SUPERVISION OF:

*Mark Lancaster*  
 DIRECTOR OF TRANSPORTATION  
 MARK LANCASTER, P.E.

11/30/22  
DATE

REVISION DESCRIPTION	MARK	DATE	APPROVED



COUNTY OF RIVERSIDE

### RIPRAP ENERGY DISSIPATOR SIZING AND CONCRETE SILL

STANDARD No. 314 (4 OF 4)

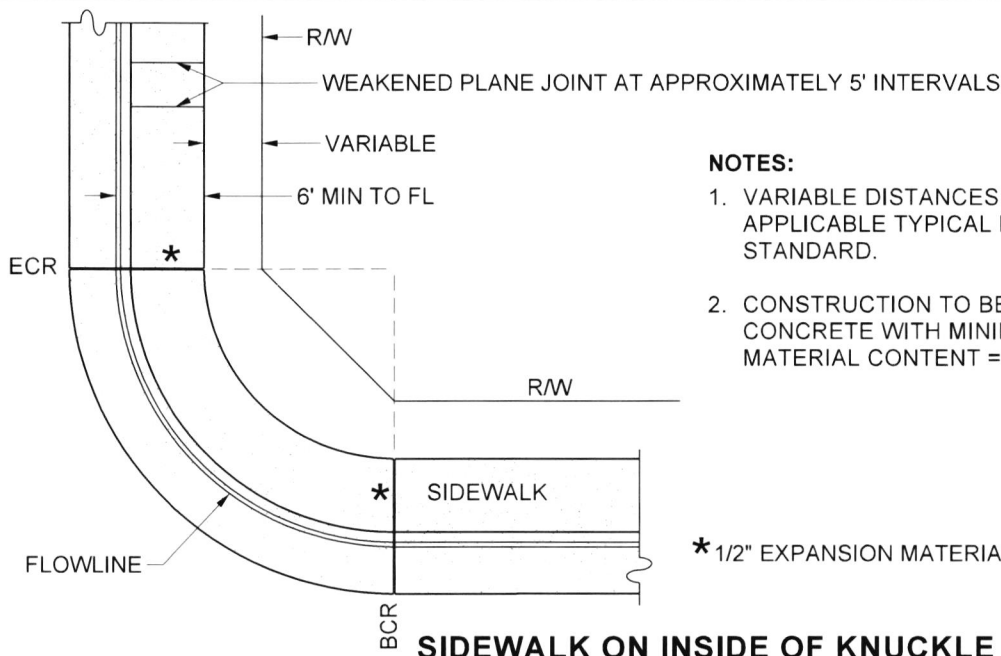

**NOTES:**

1. VARIABLE DISTANCES TO BE SHOWN ON APPLICABLE TYPICAL ROAD SECTION STANDARD.
2. CONSTRUCTION TO BE 4" MINIMUM THICKNESS CONCRETE WITH MINIMUM CEMENTITIOUS MATERIAL CONTENT = 505 LB / CU YD.

**SIDEWALK ON INSIDE OF KNUCKLE**

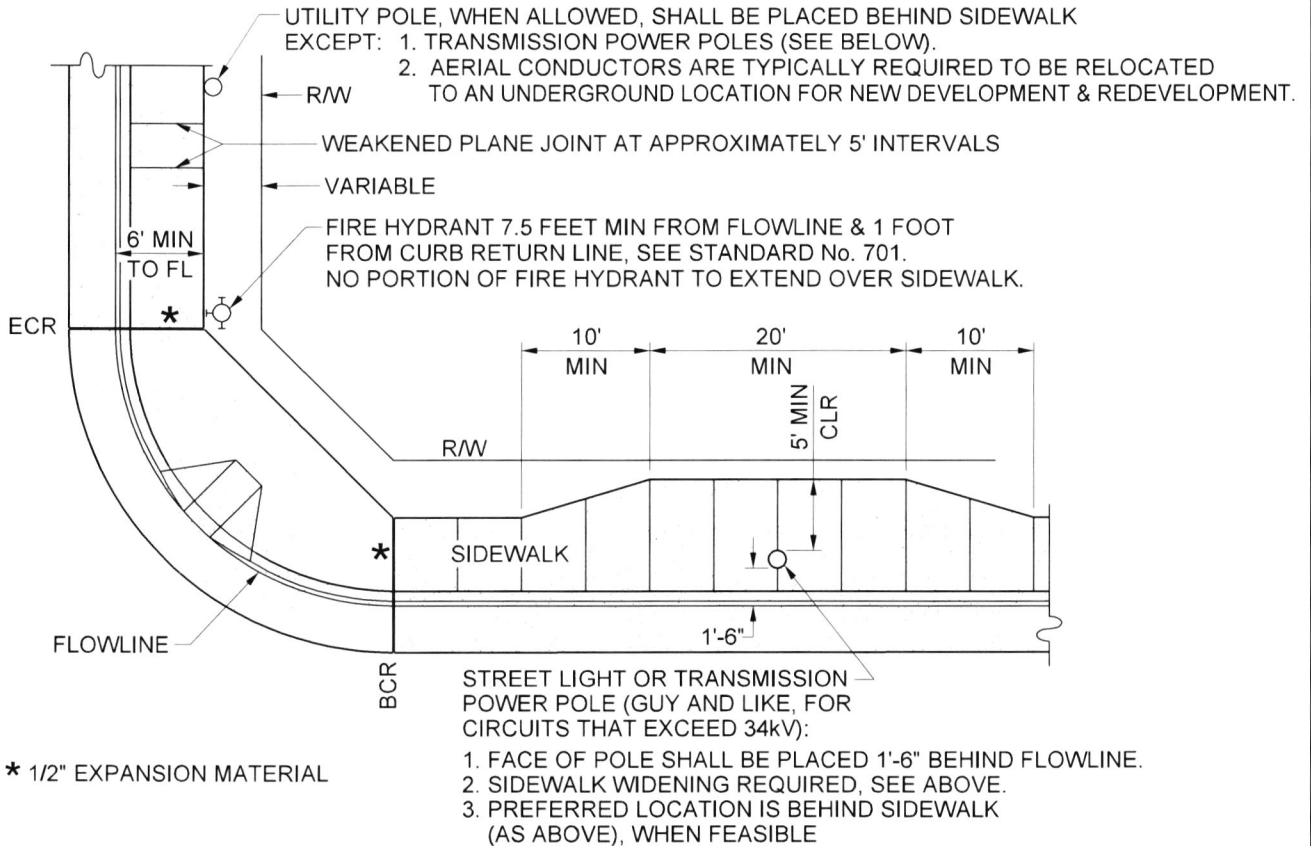

- STREET LIGHT OR TRANSMISSION POWER POLE (GUY AND LIKE, FOR CIRCUITS THAT EXCEED 34kV):
1. FACE OF POLE SHALL BE PLACED 1'-6" BEHIND FLOWLINE.
  2. SIDEWALK WIDENING REQUIRED, SEE ABOVE.
  3. PREFERRED LOCATION IS BEHIND SIDEWALK (AS ABOVE), WHEN FEASIBLE

**SIDEWALK AT INTERSECTION**

NOT TO SCALE

PREPARED UNDER THE SUPERVISION OF:

*Mark Lancaster* 11/30/22  
 DIRECTOR OF TRANSPORTATION DATE  
 MARK LANCASTER, P.E.

REVISION	DESCRIPTION	MARK	DATE	APPROVED



COUNTY OF RIVERSIDE

**SIDEWALK,  
 FIRE HYDRANT, &  
 UTILITY POLE LOCATION  
 (SIDEWALK AT CURB)**

STANDARD No. 400 (1 OF 2)

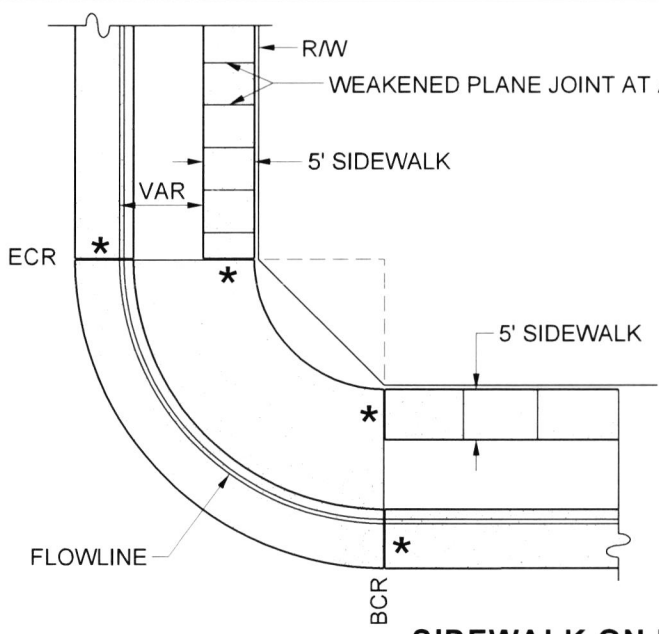

**NOTES:**

1. VARIABLE DISTANCES TO BE SHOWN ON APPLICABLE TYPICAL ROAD SECTION STANDARD.
2. CONSTRUCTION TO BE 4" MINIMUM THICKNESS CONCRETE WITH MINIMUM CEMENTITIOUS MATERIAL CONTENT = 505 LB / CU YD.

\* 1/2" EXPANSION MATERIAL

**SIDEWALK ON INSIDE OF KNUCKLE**

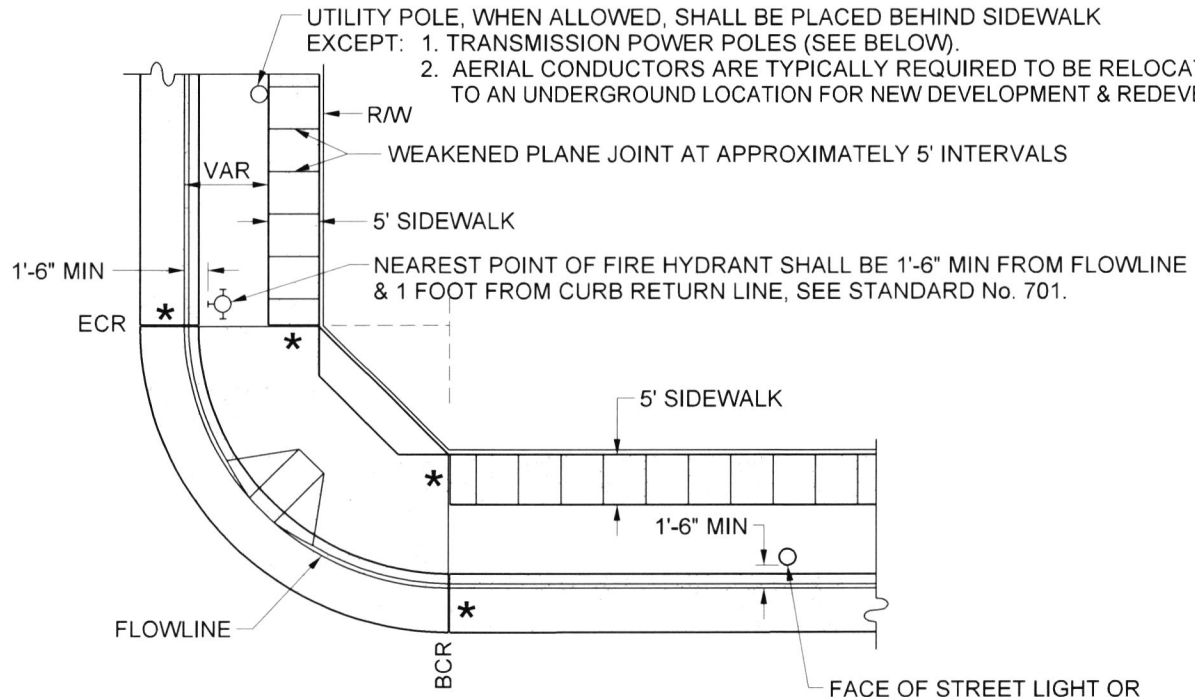

\* 1/2" EXPANSION MATERIAL

FACE OF STREET LIGHT OR TRANSMISSION POLE SHALL BE PLACED 1'-6" MIN BEHIND FLOWLINE

**SIDEWALK AT INTERSECTION**

NOT TO SCALE

PREPARED UNDER THE SUPERVISION OF:

*Mark Lancaster*  
 DIRECTOR OF TRANSPORTATION  
 MARK LANCASTER, P.E.  
 DATE 11/30/22



COUNTY OF RIVERSIDE

**SIDEWALK,  
 FIRE HYDRANT, &  
 UTILITY POLE LOCATION  
 (SIDEWALK AT R/W)**

STANDARD No. 400 (2 OF 2)

REVISION	DESCRIPTION	MARK	DATE	APPROVED

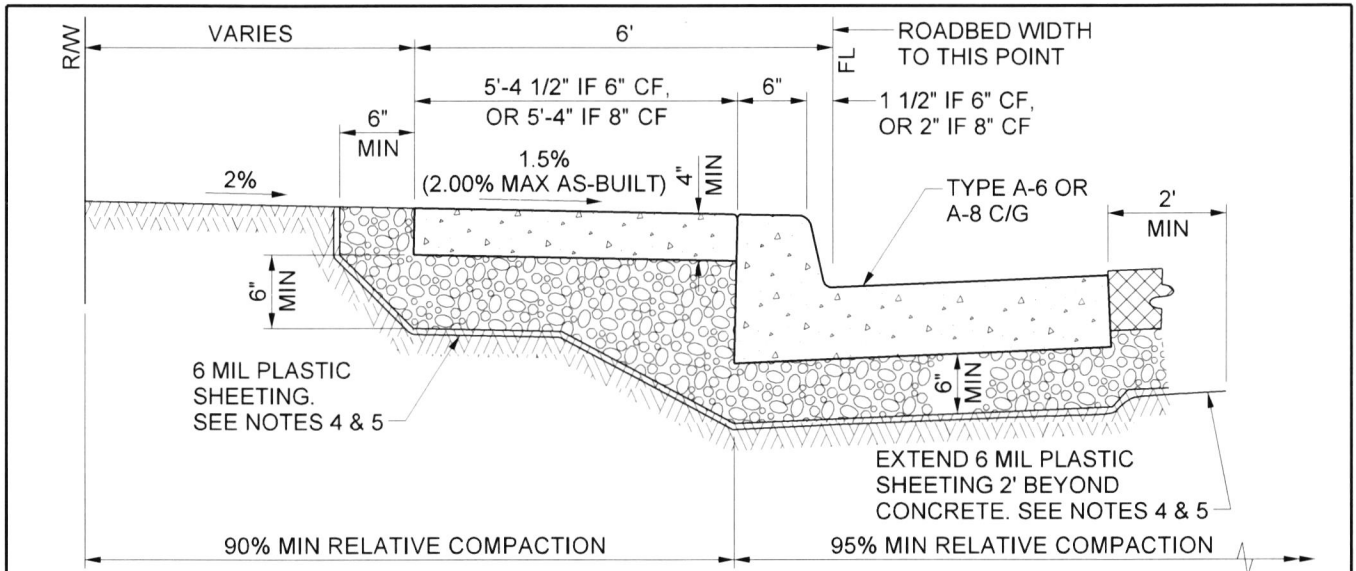

**SIDEWALK ADJACENT TO CURB**

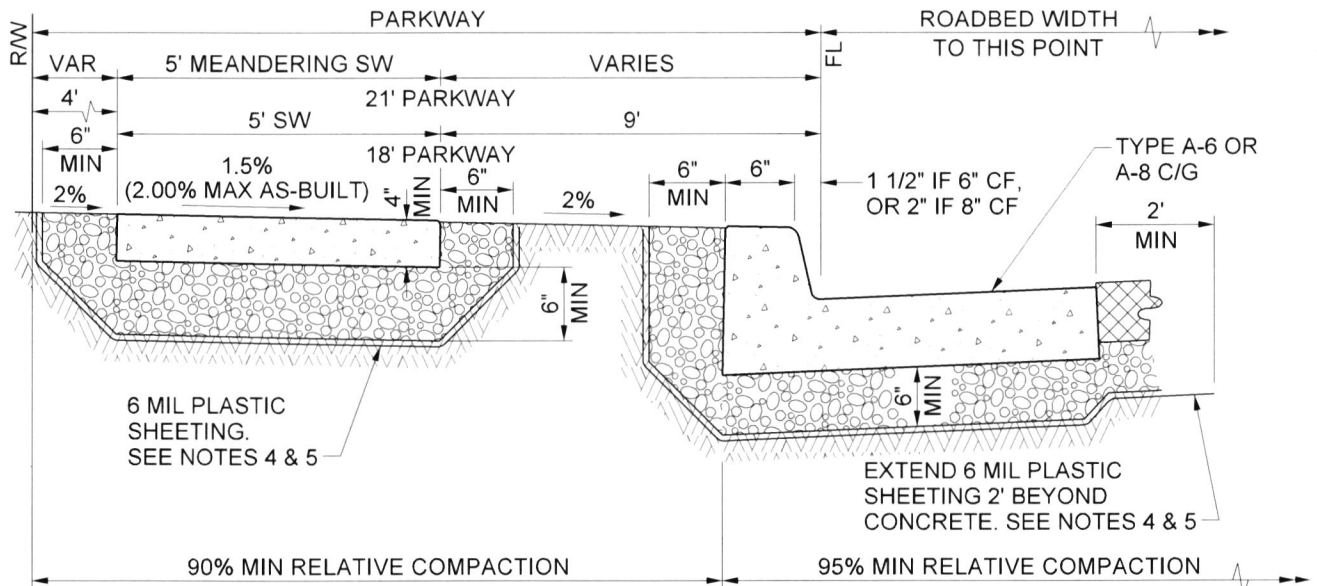

**MEANDERING SIDEWALK IN 21' PARKWAY  
SIDEWALK NOT ADJACENT TO CURB IN 18' PARKWAY**

**NOTES:**

1. ALL CONSTRUCTION SHALL BE CONCRETE WITH MINIMUM CEMENTITIOUS MATERIAL CONTENT = 505 LB/CU YD.
2. TO MAINTAIN PUBLIC PEDESTRIAN ACCESS, TEMPORARY TRAP FENCES FOR MODEL HOMES SHALL BE PLACED BEHIND PUBLIC SIDEWALK AND NOT BETWEEN PUBLIC SIDEWALK AND CURB.
3. FOR EXPANSIVE SOIL, PLACE 6" MIN CLASS 2 AGGREGATE BASE UNDER CONCRETE IMPROVEMENTS AS DIRECTED BY THE ENGINEER. SEE STANDARD SPECIFICATIONS SECTION 16.03.
4. WHEN ABUTTING SOIL HAS A HIGH SULFATE CONTENT, USE MODIFIED CONCRETE MIX AND PLACE 6" MIN CLASS 2 AGGREGATE BASE AND 6 MIL PLASTIC SHEETING UNDER AND AROUND ALL SIDES OF CONCRETE IMPROVEMENTS AND STRUCTURES. SEE COUNTY STANDARD SPECIFICATION SECTION 16.04.
5. WHEN USING 6 MIL PLASTIC SHEETING, PLACE THE SHEETING BETWEEN THE CLASS 2 AGGREGATE BASE AND THE COMPACTED NATIVE SOIL. EXTEND THE SHEETING 2 FEET BEYOND THE EDGE OF CONCRETE GUTTER INTO THE ROADWAY. IN ORDER TO PREVENT DAMAGE TO THE PLASTIC SHEETING RESULTING FROM LATER GRADING AND COMPACTING, PLACE THE EXTENDED 2 FEET OF SHEETING ONLY AFTER THE SUBGRADE HAS BEEN CERTIFIED BY THE SURVEYOR.

NOT TO SCALE

PREPARED UNDER THE SUPERVISION OF:

*Mark Lancaster* 11/30/22  
 DIRECTOR OF TRANSPORTATION DATE  
 MARK LANCASTER, P.E.

REVISION	DESCRIPTION	MARK	DATE	APPROVED



COUNTY OF RIVERSIDE

**SIDEWALK AND CURB**

**STANDARD No. 401**

**NOTE:**

IMPROVEMENT PLANS SHALL INCLUDE DETAILS WITH ELEVATIONS, SLOPES AND WIDTHS FOR ANY CURB RAMP CASE A WITH ADJACENT STREET GRADES OVER 5%.

DELTA = TOTAL ANGLE BETWEEN BCR AND ECR

WEAKENED PLANE JOINT

EXPANSION JOINT  
SEE STANDARD No. 205

BACK OF CURB  
EG

1 1/2" x 3/16" TOOLED JOINT AT ALL RAMP GRADE BREAKS

CURB AND GUTTER DETAILS PER STANDARD No. 200 OR 201

WEAKENED PLANE JOINT ALIGNS WITH 1/4 DELTA RADIAL AT BACK OF CURB

1/2 DELTA

RADIUS = 25' OR 35'  
ECR

1/4 DELTA  
1/4 DELTA  
1/4 DELTA  
1/4 DELTA

BCR

6' TO FL

SEE STANDARD No. 805 FOR CURB RETURN RADIUS

4.00' x 4.00' MIN LANDING

SEE TABLE Y BELOW

CROSSWALK  
SEE NOTE 15

SEE TABLE X ON SHEET 3

FOR PUBLIC WORKS PROJECTS, PAY QUANTITY FOR CURB RAMP CONSTRUCTION SHALL INCLUDE CURB AND GUTTER AND SIDEWALK FROM BCR TO ECR

**PLAN**

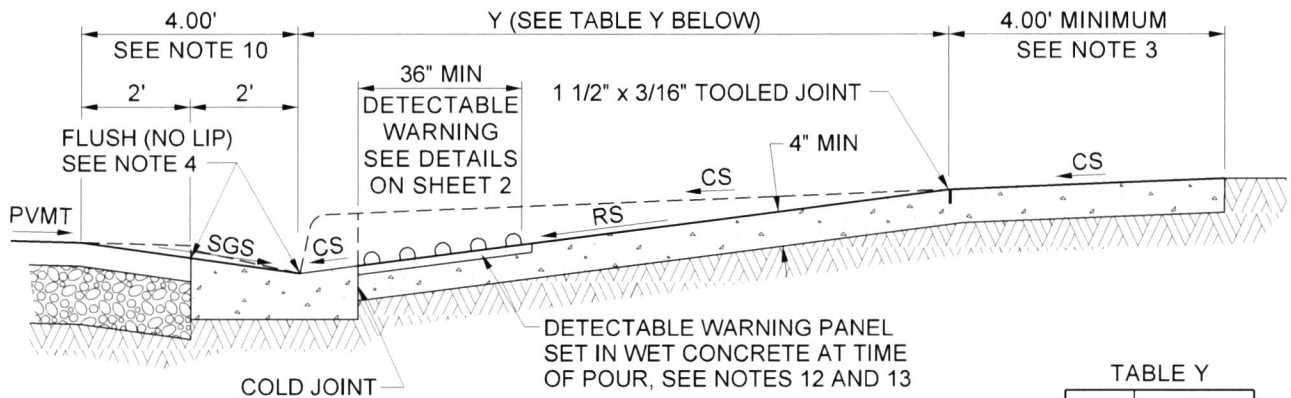

**SECTION "A-A"**

TABLE Y

CF	Y
6"	8.93'
8"	11.74'

**ABBREVIATIONS AND VALUES:**

- RS = RAMP SLOPE: 7.5% (8.33% MAX AS-BUILT)
- CS = CROSS SLOPE: 1.5% (2.00% MAX AS-BUILT)
- TS = TRANSITION SLOPE: 9.0% (10.00% MAX AS-BUILT)
- SGS = STREET & GUTTER SLOPE: 5.00% MAX AS-BUILT
- WA = WIDTH A: 4.00' MIN AS-BUILT
- FS = FLOWLINE SLOPE AT CURB OPENING:
  - 1.50% (2.00% MAX AS-BUILT) FOR LEGS WITH STOP OR YIELD CONTROL.
  - 4.50% (5.00% MAX AS-BUILT) FOR LEGS WITHOUT STOP, YIELD, OR GREEN LIGHT SIGNALIZATION.
  - STREET % FOR MID-BLOCK CROSSINGS.

MOTOR VEHICLES ARE PROHIBITED FROM USING CURB RAMPS AS ACCESS ONTO PRIVATE PROPERTY.

NOT TO SCALE

SEE ALL NOTES ON SHEET 7

PREPARED UNDER THE SUPERVISION OF:

*Mark Lancaster*  
 DIRECTOR OF TRANSPORTATION  
 MARK LANCASTER, P.E.  
 DATE 11/30/22



COUNTY OF RIVERSIDE

**CURB RAMP  
CASE A**

STANDARD No. 403 (1 OF 7)

REVISION	DESCRIPTION	MARK	DATE	APPROVED

**NOTE:**  
IMPROVEMENT PLANS SHALL INCLUDE DETAILS WITH ELEVATIONS, SLOPES AND WIDTHS FOR ANY CURB RAMP CASE B WITH ADJACENT STREET GRADES OVER 5%.

DELTA = TOTAL ANGLE BETWEEN BCR AND ECR

WEAKENED PLANE JOINT  
SEE STANDARD No. 805 FOR CURB RETURN RADIUS

BACK OF WALK  
BACK OF CURB  
FL

CURB AND GUTTER DETAILS PER STANDARD No. 200 OR 201

1 1/2" x 3/16" TOOLED JOINT AT ALL RAMP GRADE BREAKS

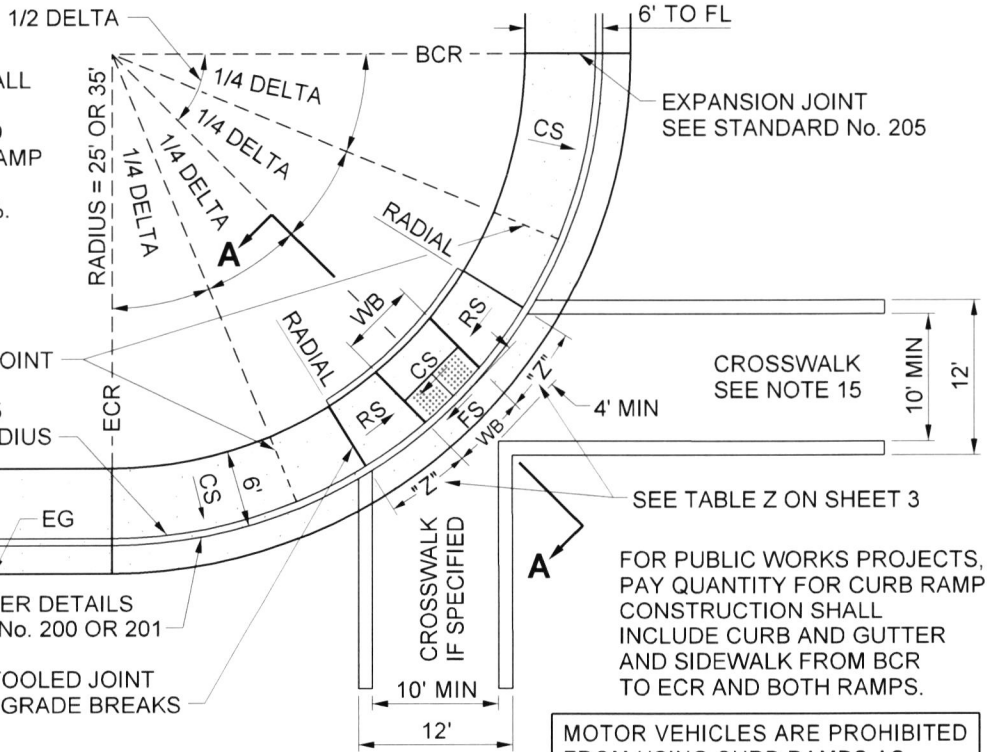

MOTOR VEHICLES ARE PROHIBITED FROM USING CURB RAMP AS ACCESS ONTO PRIVATE PROPERTY.

**PLAN**

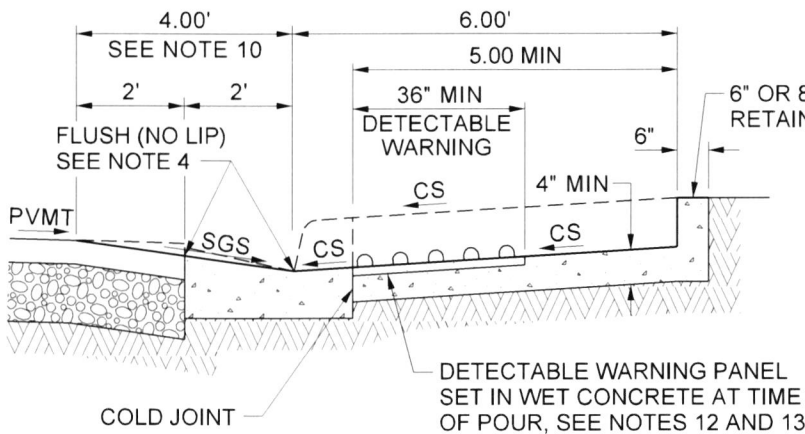

**SECTION "A-A"**

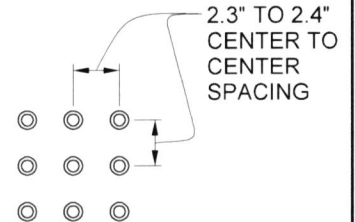

**RAISED TRUNCATED DOME PATTERN  
DETECTABLE WARNING SURFACE**  
SEE NOTES 11, 12 & 13

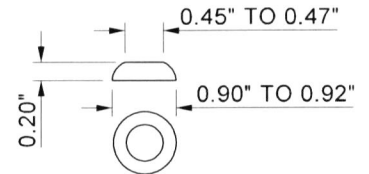

**RAISED TRUNCATED DOME**  
SEE NOTE 11

**ABBREVIATIONS AND VALUES:**

WB = WIDTH B: 5.00' MIN AS-BUILT (SEE NOTE 16)  
SEE SHEET 1 FOR ADDITIONAL ABBREVIATIONS AND VALUES

NOT TO SCALE

SEE ALL NOTES ON SHEET 7

PREPARED UNDER THE SUPERVISION OF:

*Mark Lancaster*  
MARK LANCASTER, P.E.

11/30/22  
DATE



COUNTY OF RIVERSIDE

**CURB RAMP  
CASE B**

REVISION	DESCRIPTION	MARK	DATE	APPROVED

**STANDARD No. 403 (2 OF 7)**

RS = RAMP SLOPE: 7.5% (8.33% MAX AS-BUILT)  
 TS = TRANSITION SLOPE: 9.0% (10.00% MAX AS-BUILT)  
 FS = FLOWLINE SLOPE AT CURB OPENING:

- 1.50% (2.00% MAX AS-BUILT) FOR LEGS WITH STOP OR YIELD CONTROL.
- 4.50% (5.00% MAX AS-BUILT) FOR LEGS WITHOUT STOP, YIELD, OR GREEN LIGHT SIGNALIZATION.
- STREET % FOR MID-BLOCK CROSSINGS.

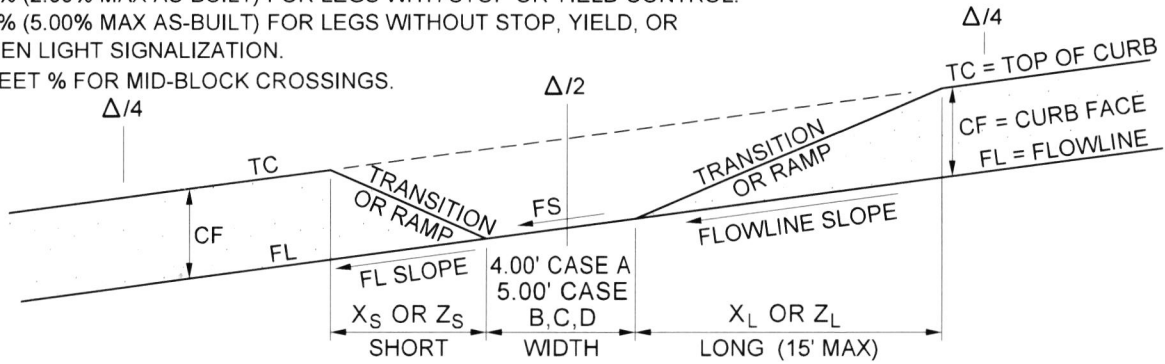

**PROFILE**

**TABLE X - CASE "A" TRANSITION LENGTH ALONG CURB RETURN (FEET)**

CF	TRANSITION SLOPE	X	FLOWLINE SLOPE (ALONG CURB RETURN)					
			1%	2%	3%	4%	5%	6%
6"	9.0%	X <sub>S</sub>	5.00	4.55	4.17	3.85	3.57	3.33
		X <sub>L</sub>	6.25	7.14	8.33	10.11	12.50	16.67
8"	9.0%	X <sub>S</sub>	6.67	6.06	5.56	5.13	4.76	4.44
		X <sub>L</sub>	8.33	9.52	11.11	13.33	16.67	22.22

NOTE: THE TRANSITION LENGTH IS NOT REQUIRED TO GO BEYOND THE BCR OR ECR, NOR EXCEED 15' IN LENGTH.

**TABLE Z - CASE "B", "C" AND "D" RAMP LENGTH ALONG BACK OF WALK (FEET)**

CF	RAMP SLOPE	Z	FLOWLINE SLOPE (ALONG CURB)					
			1%	2%	3%	4%	5%	6%
6"	7.5%	Z <sub>S</sub>	5.88	5.26	4.76	4.35	4.00	3.70
		Z <sub>L</sub>	7.69	9.09	11.11	14.29	15.0*	15.0*
8"	7.5%	Z <sub>S</sub>	7.84	7.02	6.35	5.80	5.33	4.94
		Z <sub>L</sub>	10.26	12.12	14.81	15.0*	15.0*	15.0*

\* NOTE: RAMP LENGTH IS NOT REQUIRED TO EXCEED 15.0' ALONG THE BACK OF WALK.

**TO CALCULATE "X" OR "Z" LENGTH:**

SHORT SIDE (DOWN SLOPE):  
 CURB FACE (FEET)  
 $X_S \text{ OR } Z_S(\text{FT}) = \frac{\text{CURB FACE (FEET)}}{\text{TRANS OR RAMP SLOPE} + \text{FL SLOPE}}$

LONG SIDE (UP SLOPE):  
 CURB FACE (FEET)  
 $X_L \text{ OR } Z_L(\text{FT}) = \frac{\text{CURB FACE (FEET)}}{\text{TRANS OR RAMP SLOPE} - \text{FL SLOPE}}$

ENGINEER TO SHOW X<sub>S</sub>, X<sub>L</sub>, Z<sub>S</sub>, AND Z<sub>L</sub> ON IMPROVEMENT PLANS

NOT TO SCALE

SEE ALL NOTES ON SHEET 7

PREPARED UNDER THE SUPERVISION OF:

*Mark Lancaster*  
 11/30/22  
 DIRECTOR OF TRANSPORTATION DATE  
 MARK LANCASTER, P.E.

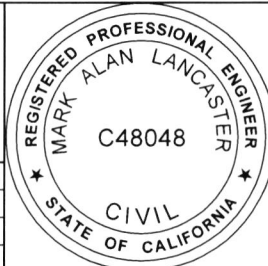

COUNTY OF RIVERSIDE

**CURB RAMP PROFILE**

STANDARD No. 403 (3 OF 7)

REVISION	DESCRIPTION	MARK	DATE	APPROVED

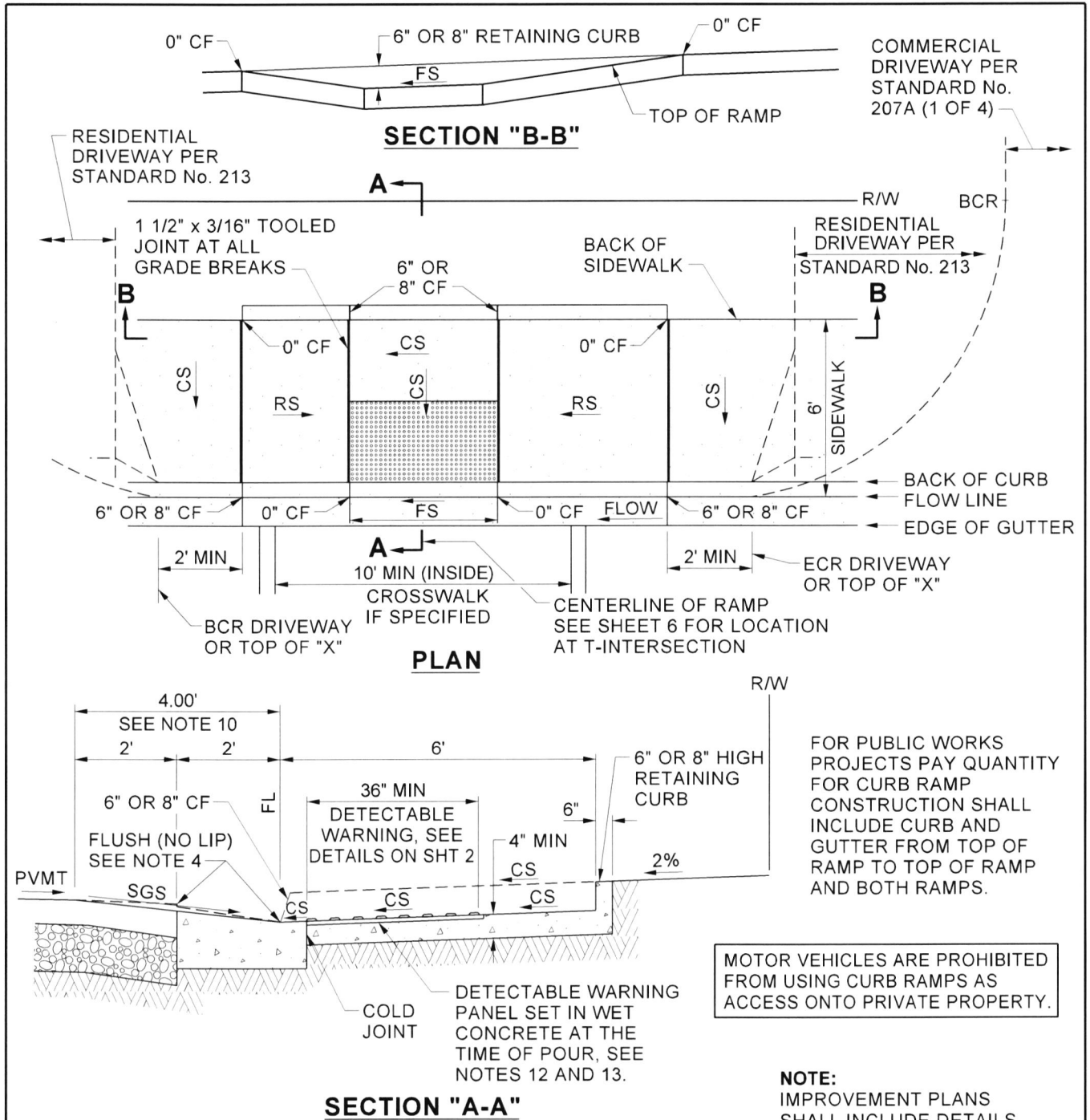

COMMERCIAL DRIVEWAY PER STANDARD No. 207A (1 OF 4)

RESIDENTIAL DRIVEWAY PER STANDARD No. 213

RESIDENTIAL DRIVEWAY PER STANDARD No. 213

BACK OF CURB FLOW LINE  
EDGE OF GUTTER

FOR PUBLIC WORKS PROJECTS PAY QUANTITY FOR CURB RAMP CONSTRUCTION SHALL INCLUDE CURB AND GUTTER FROM TOP OF RAMP TO TOP OF RAMP AND BOTH RAMPS.

MOTOR VEHICLES ARE PROHIBITED FROM USING CURB RAMPS AS ACCESS ONTO PRIVATE PROPERTY.

**NOTE:**  
IMPROVEMENT PLANS SHALL INCLUDE DETAILS WITH ELEVATIONS, SLOPES AND WIDTHS FOR ANY CURB RAMP CASE C WITH STREET GRADES OVER 5%.

ABBREVIATIONS AND VALUES: SEE SHEET 1

NOT TO SCALE

SEE ALL NOTES ON SHEET 7

PREPARED UNDER THE SUPERVISION OF:

*Mark Lancaster*

11/30/22  
DATE

DIRECTOR OF TRANSPORTATION  
MARK LANCASTER, P.E.



COUNTY OF RIVERSIDE

**CURB RAMP - CASE C  
"T" INTERSECTION  
WITH SIDEWALK AT CURB**

STANDARD No. 403 (4 OF 7)

REVISION	DESCRIPTION	MARK	DATE	APPROVED



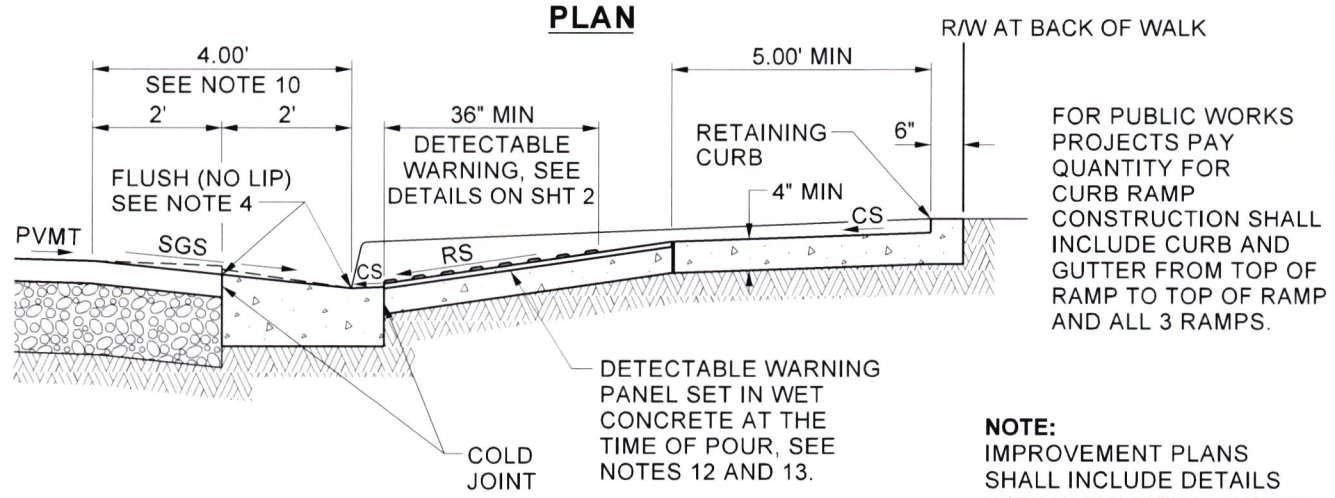
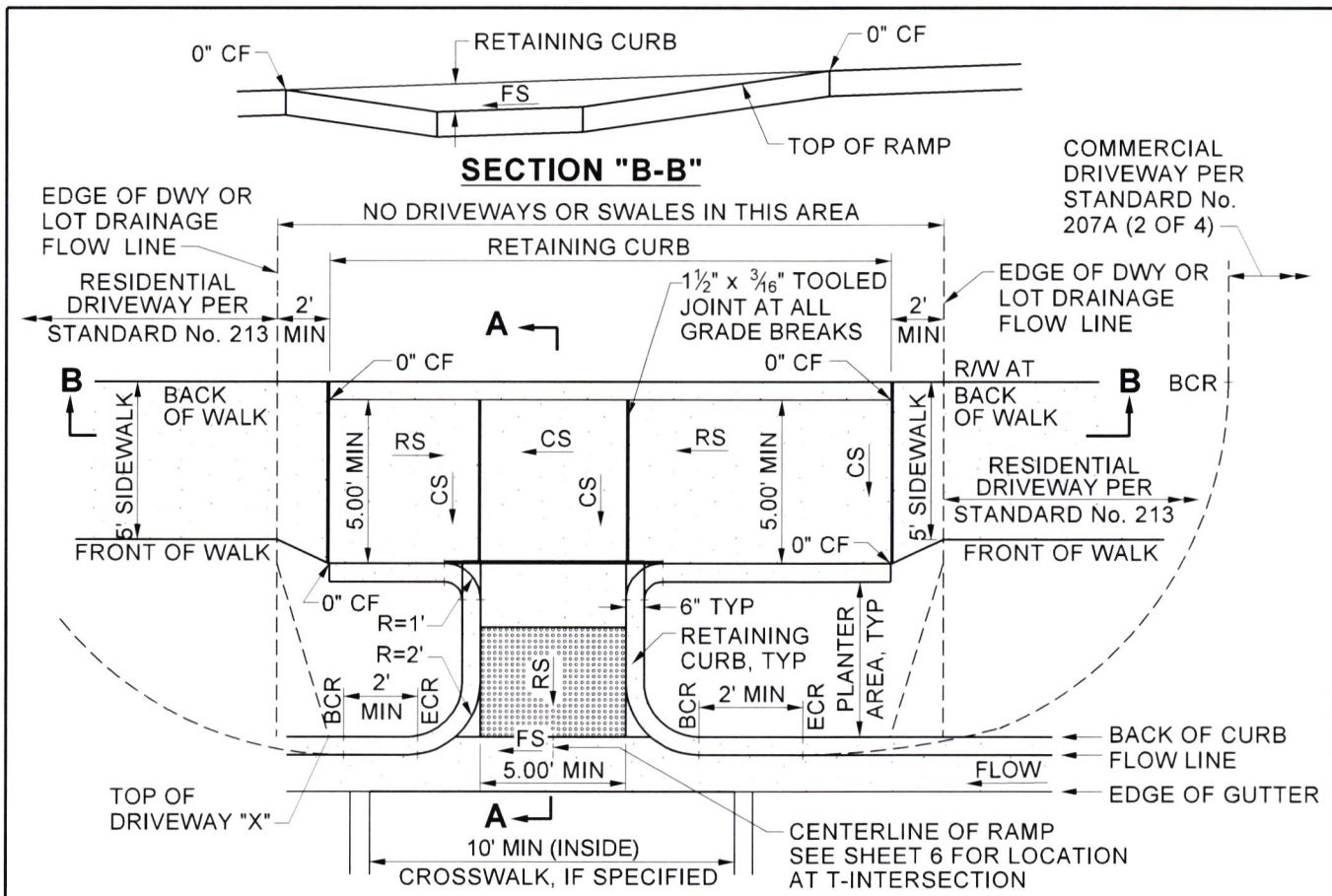

ABBREVIATIONS AND VALUES: SEE SHEET 1

NOT TO SCALE SEE ALL NOTES ON SHEET 7

PREPARED UNDER THE SUPERVISION OF:

*Mark Lancaster*

11/30/22

DIRECTOR OF TRANSPORTATION DATE

MARK LANCASTER, P.E.



COUNTY OF RIVERSIDE

**CURB RAMP - CASE D**

**"T" INTERSECTION**

**WITH SIDEWALK AT R/W**

STANDARD No. 403 (5 OF 7)

REVISION	DESCRIPTION	MARK	DATE	APPROVED

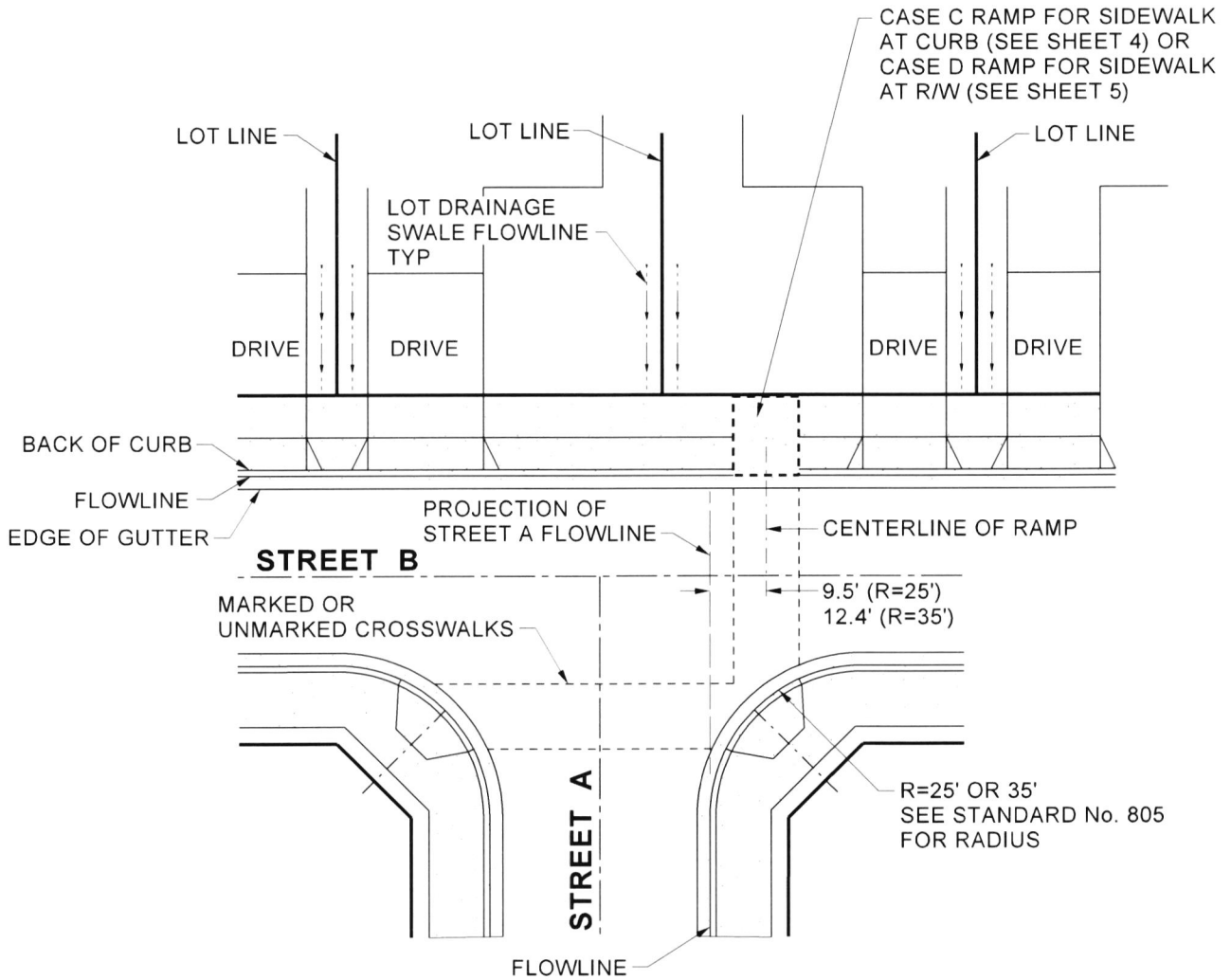

**RAMP LOCATION AT "T" INTERSECTION  
(RIGHT TURN SIDE OF STREET A)**

**CASES "C" AND "D"**

**NOTE:**  
DRIVEWAYS TO BE LOCATED SO THAT THEY DO NOT CONFLICT WITH REQUIRED RAMP LOCATION. AVOID LOCATING DRIVEWAYS WITHIN INTERSECTION.

NOT TO SCALE

SEE ALL NOTES ON SHEET 7

PREPARED UNDER THE SUPERVISION OF:

*Mark Lancaster*  
DIRECTOR OF TRANSPORTATION  
MARK LANCASTER, P.E.

11/30/22  
DATE



COUNTY OF RIVERSIDE

**CURB RAMP  
CASE C AND D  
LOCATION AT  
"T" INTERSECTIONS**

STANDARD No. 403 (6 OF 7)

REVISION	DESCRIPTION	MARK	DATE	APPROVED

**NOTES:**

1. TO MEET AMERICAN WITH DISABILITIES ACT STANDARDS, MAXIMUM STATED SLOPES AND MINIMUM STATED DISTANCES ARE ABSOLUTE AND NO CONSTRUCTION TOLERANCES WILL BE PERMITTED.
2. IF THE DISTANCE FROM CENTER OF CURB RETURN TO EXISTING RIGHT-OF-WAY LINE IS INSUFFICIENT TO ACCOMMODATE THE CASE A CURB RAMP AND TOP LANDING, THEN USE THE CASE B CURB RAMP.
3. THE MINIMUM SIDEWALK WIDTH IS 5.00' WHERE A VERTICAL OBJECT (SUCH AS A CURB OR WALL) IS ADJACENT TO THE PEDESTRIAN ACCESS ROUTE.
4. TRANSITIONS FROM CURB RAMPS TO SIDEWALKS, GUTTERS, AND STREETS SHALL BE FLUSH AND FREE FROM ABRUPT LEVEL CHANGES. NO LIPS ARE PERMITTED AT THE GUTTER FLOWLINE OR EDGE OF PAVEMENT.
5. THE TOP OF CURB WIDTH IS NOT INCLUDED IN THE MEASUREMENT OF MINIMUM SIDEWALK WIDTH.
6. THE TRANSITION SLOPE OF THE FLARED WINGS OF THE CASE A CURB RAMP IS MEASURED ALONG THE BACK OF CURB.
7. FOR CASE B CURB RAMPS, CONSTRUCT WEAKENED PLANE JOINTS AT 1/4 DELTAS WHEN THE RADIUS EQUALS 35' AND AT TOPS OF RAMPS WHEN THE RADIUS EQUALS 25'.
8. WHEN ABUTTING SOIL HAS A HIGH SULFATE CONTENT, USE A MODIFIED CONCRETE MIX AND PLACE 6" MIN CLASS 2 AGGREGATE BASE AND 6 MIL PLASTIC SHEETING UNDER AND AROUND ALL SIDES OF CONCRETE IMPROVEMENTS. FOR EXPANSIVE SOIL, PLACE 6" MIN CLASS 2 AGGREGATE BASE UNDER CONCRETE IMPROVEMENTS AS DIRECTED BY THE ENGINEER. SEE SPECIFICATIONS SECTIONS 16.03 & 16.04 AND STANDARD No. 401 FOR REFERENCE.
9. CONCRETE SHALL HAVE MINIMUM CEMENTITIOUS MATERIAL CONTENT = 505 LB / CU YD.
10. THE ROAD SURFACE AND GUTTER SURFACE SHALL NOT EXCEED 5.00% WITHIN 4' OF THE CURB RAMP EDGE (FLOW LINE).
11. DETECTABLE WARNING SURFACES ARE REQUIRED WHEREVER AT-GRADE PEDESTRIAN SURFACES ENTER INTO A VEHICULAR TRAVEL WAY (EXCEPT NOT REQUIRED AT DRIVEWAY APPROACHES).
12. CURB RAMPS SHALL INCLUDE A YELLOW DETECTABLE WARNING SURFACE THAT EXTENDS THE FULL CURB OPEN WIDTH AND 3'-0" DEPTH OF THE RAMP. DETECTABLE WARNING SURFACES SHALL CONSIST OF A PANEL SET INTO WET CONCRETE AND CONFORM TO THE DETAILS ON SHEET 2 OF THIS STANDARD. NO BOLT DOWN OR GLUE DOWN PANELS WILL BE ALLOWED FOR NEW RAMP CONSTRUCTION.
13. THE EDGE OF THE DETECTABLE WARNING SURFACE NEAREST THE STREET SHALL BE BETWEEN 6" AND 8" FROM THE GUTTER FLOWLINE.
14. UTILITY PULL BOXES, MANHOLES, VAULTS AND ALL OTHER UTILITY FACILITIES ARE NOT TO BE LOCATED WITHIN THE BOUNDARIES OF THE CURB RAMP. EXISTING STRUCTURES WILL BE RELOCATED OR ADJUSTED TO GRADE BY THE OWNER PRIOR TO, OR IN CONJUNCTION WITH, CURB RAMP CONSTRUCTION.
15. CROSSWALK STRIPING IS ONLY APPLIED IF SHOWN ON IMPROVEMENT PLANS. CROSSWALK STRIPING, WHEN CALLED FOR, SHALL BE PER STANDARD No. 1211.
16. FOR NEW CASE B, CASE C, AND CASE D CURB RAMPS THE LEVEL LANDING AT THE BOTTOM OF THE RAMPS SHALL BE A MINIMUM OF 5.00' WIDE. FOR INVENTORYING EXISTING CASE B AND CASE C RAMPS, A CURB OPENING WIDTH OF 4.00' MIN IS ACCEPTABLE.
17. FOR PUBLIC WORKS PROJECTS, THE CONTRACT UNIT PRICE FOR CURB RAMP SHALL INCLUDE RAMP, SIDEWALK, CURB AND GUTTER (OR SPANDREL) FROM BCR TO ECR.

NOT TO SCALE

PREPARED UNDER THE SUPERVISION OF:

*Mark Lancaster*  
 11/30/22  
 DIRECTOR OF TRANSPORTATION DATE  
 MARK LANCASTER, P.E.

REVISION	DESCRIPTION	MARK	DATE	APPROVED



COUNTY OF RIVERSIDE

**CURB RAMP  
 NOTES**

**STANDARD No. 403 (7 OF 7)**

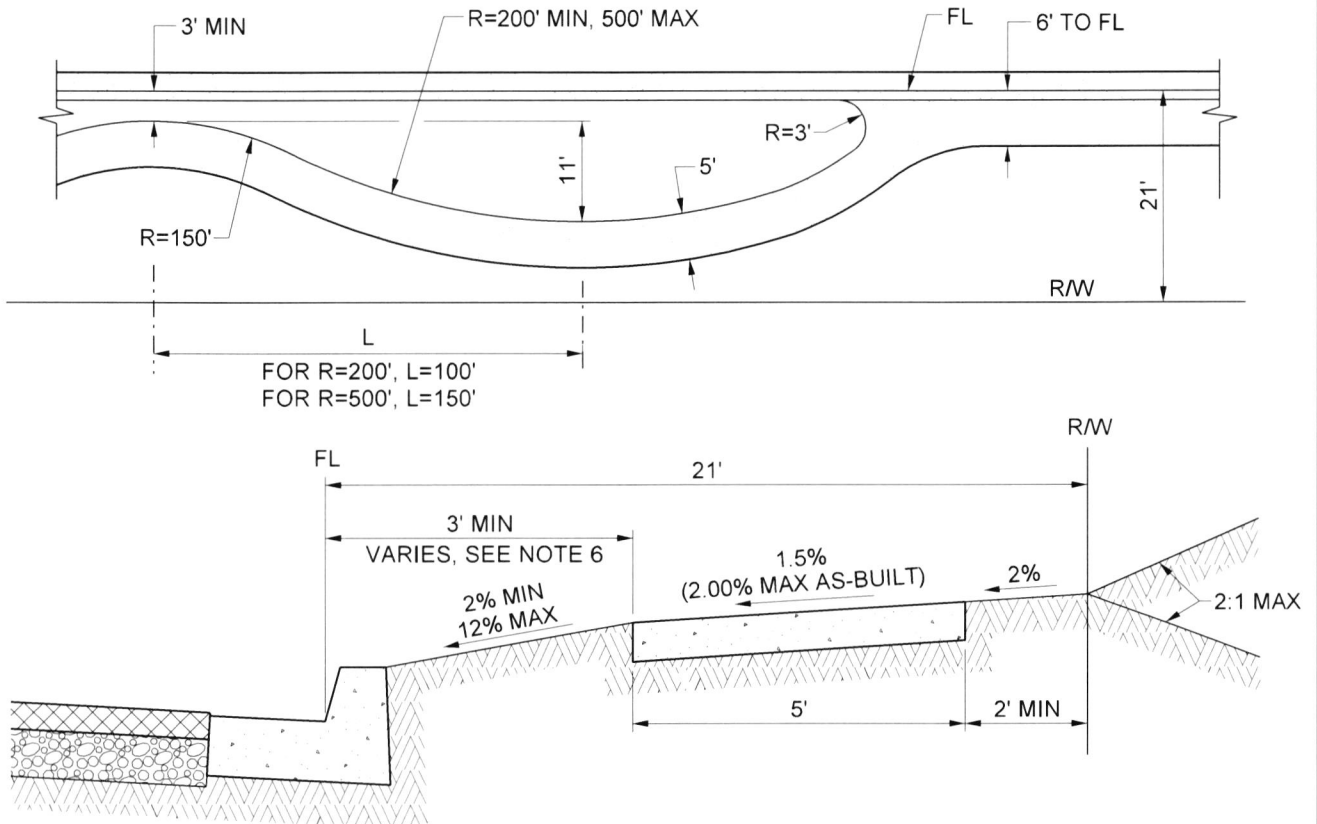

**NOTES:**

1. RADII FOR CURVED SIDEWALK SHALL VARY BETWEEN 200' AND 500' AT FRONT OF SIDEWALK.
2. SIDEWALK SHALL BE A MINIMUM OF 6' WIDTH ADJACENT TO CURB.
3. SIDEWALK SHALL BE 3' MIN AWAY FROM FLOW LINE EXCEPT AT CURB RETURNS, BUS STOPS, AND AT TOP OF "T" INTERSECTIONS WHERE CURB RAMP ARE REQUIRED.
4. SIDEWALK LAYOUT ON PLANS IS CONCEPTUAL ONLY. APPROVAL OF THE FINAL SIDEWALK LAYOUT SHALL BE MADE IN THE FIELD AND ADJUSTED AS NECESSARY TO MEET FIELD CONDITIONS AS APPROVED BY THE INSPECTOR PRIOR TO FINAL CONSTRUCTION.
5. WHEN ABUTTING SOIL HAS A HIGH SULFATE CONTENT, USE A MODIFIED CONCRETE MIX AND PLACE 6" MIN CLASS 2 AGGREGATE BASE AND 6 MIL PLASTIC SHEETING UNDER AND AROUND ALL SIDES OF CONCRETE IMPROVEMENTS. FOR EXPANSIVE SOIL, PLACE 6" MIN CLASS 2 AGGREGATE BASE UNDER CONCRETE IMPROVEMENTS AS DIRECTED BY THE ENGINEER. SEE SPECIFICATIONS SECTIONS 16.03 & 16.04 AND STANDARD No. 401 FOR REFERENCE.
6. IRRIGATION TYPE TO BE LOW VOLUME OR SUBSURFACE BETWEEN WALK AND CURB.
7. CONCRETE MINIMUM CEMENTITIOUS MATERIAL CONTENT = 505 LB / CU YD.
8. THE RUNNING SLOPE OF SIDEWALK MAY EQUAL THE STREET SLOPE, EVEN IF THE STREET SLOPE IS GREATER THAN 8.33%. WHERE SIDEWALK EXCEEDS THE STREET SLOPE, SUCH AS TRANSITIONS IN ELEVATION OF MEANDERING SIDEWALK, A SIDEWALK RUNNING SLOPE GREATER THAN 5% WOULD BE CONSIDERED A RAMP. IN THIS CASE, RAMPS WOULD BE DESIGNED AT 7.5% MAX (8.33% MAX AS-BUILT) RUNNING SLOPE AND REQUIRE LANDINGS AS SPECIFIED IN THE 2010 ADA STANDARDS.

NOT TO SCALE

PREPARED UNDER THE SUPERVISION OF: DIRECTOR OF TRANSPORTATION MARK LANCASTER, P.E.				11/30/22 DATE		COUNTY OF RIVERSIDE
<h2 style="margin: 0;">MEANDERING SIDEWALK</h2>				<b>STANDARD No. 404</b>		
REVISION DESCRIPTION	MARK	DATE	APPROVED			

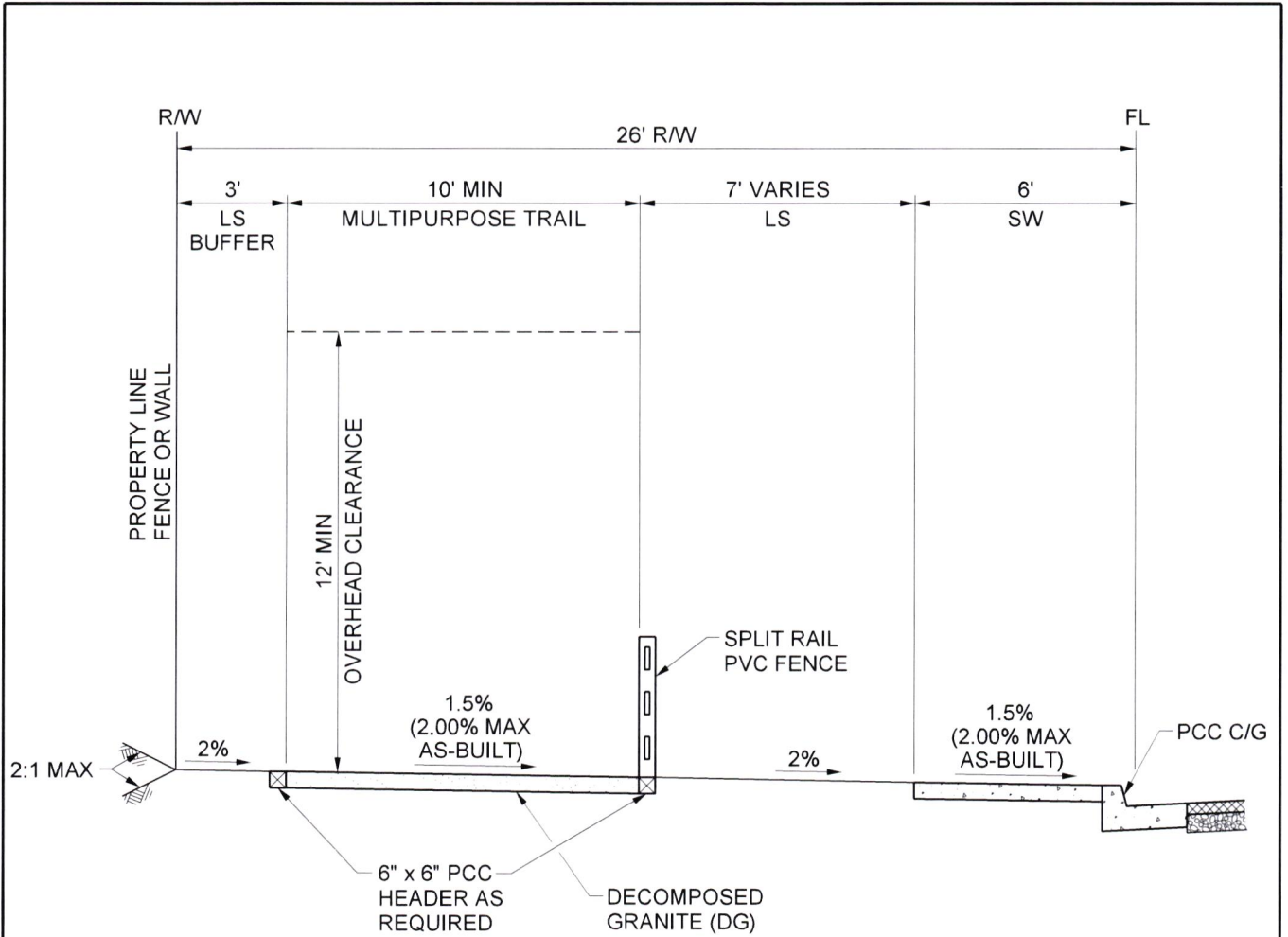

**NOTES:**

1. OMIT FENCE WITHIN SIGHT DISTANCE OF RESTRICTED USE AREAS.
2. TRAIL AND FENCE TO BE CONSTRUCTED PER LATEST DETAILS.
3. FOR TRAIL AND FENCE DETAILS, REFER TO THE COUNTY OF RIVERSIDE COMPREHENSIVE LANDSCAPE GUIDELINES AND STANDARDS.

NOT TO SCALE

PREPARED UNDER THE SUPERVISION OF:

*Mark Lancaster*  
 11/30/22  
 DIRECTOR OF TRANSPORTATION DATE  
 MARK LANCASTER, P.E.

REVISION	DESCRIPTION	MARK	DATE	APPROVED



COUNTY OF RIVERSIDE

**MULTIPURPOSE TRAIL**

**STANDARD No. 405**

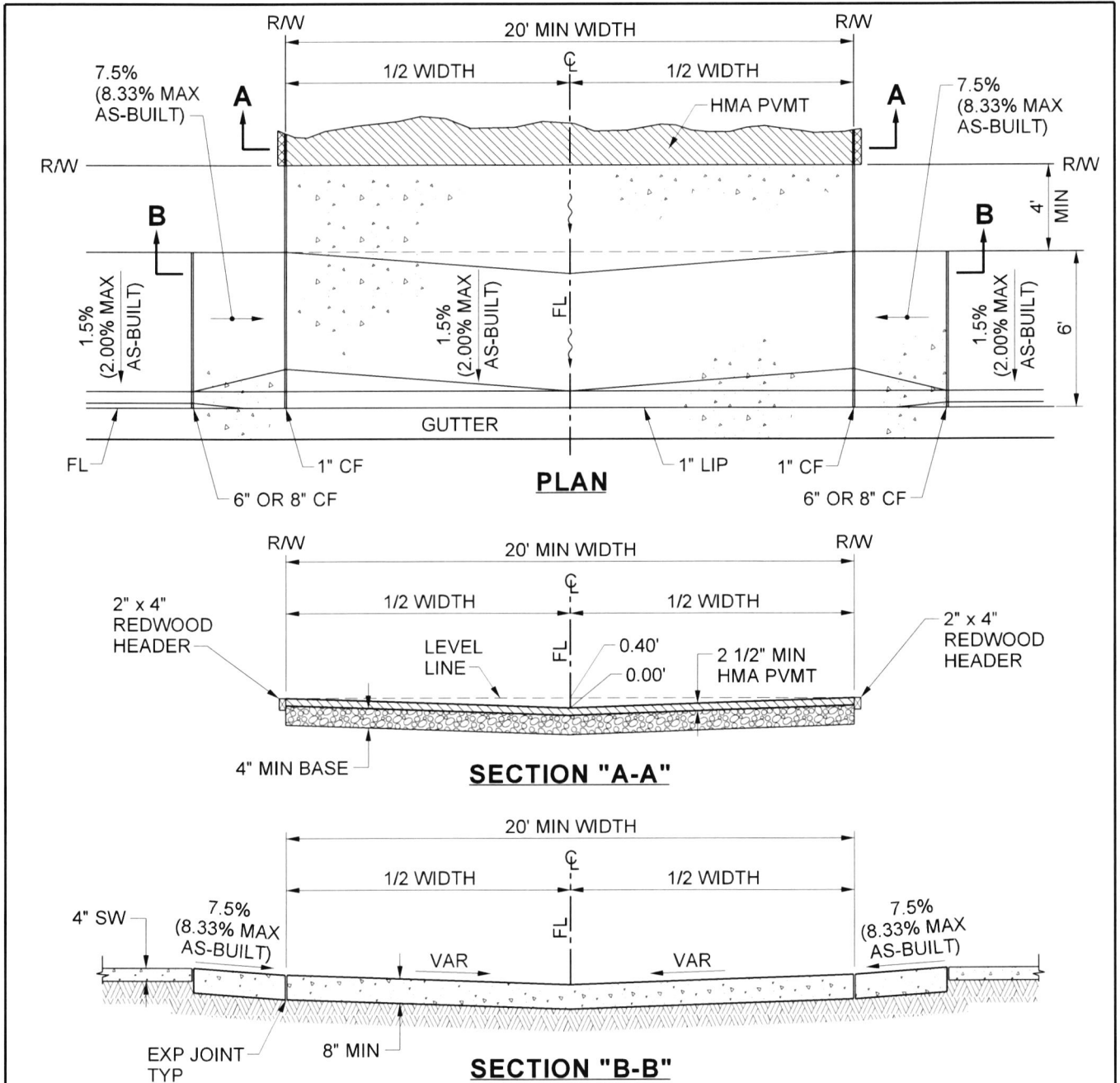

**NOTES:**

1. ALLEY WIDTH AS SPECIFIED BY THE DIRECTOR OF TRANSPORTATION.
2. ALLEY APRON SHALL BE 8" THICK CONCRETE WITH MINIMUM CEMENTITIOUS MATERIAL CONTENT = 590 LB / CU FT.
3. WHEN ABUTTING SOIL HAS A HIGH SULFATE CONTENT, USE A MODIFIED CONCRETE MIX AND PLACE 6" MIN CLASS 2 AGGREGATE BASE AND 6 MIL PLASTIC SHEETING UNDER AND AROUND ALL SIDES OF CONCRETE IMPROVEMENTS. FOR EXPANSIVE SOIL, PLACE 6" MIN CLASS 2 AGGREGATE BASE UNDER CONCRETE IMPROVEMENTS AS DIRECTED BY THE ENGINEER. SEE SPECIFICATIONS SECTIONS 16.03 & 16.04 AND STANDARD No. 401 FOR REFERENCE.
4. RELATIVE COMPACTION OF SUBGRADE SHALL BE 95% MIN.

NOT TO SCALE

PREPARED UNDER THE SUPERVISION OF:

*Mark Lancaster*  
 DIRECTOR OF TRANSPORTATION  
 MARK LANCASTER, P.E.  
 11/30/22  
 DATE



COUNTY OF RIVERSIDE

**ALLEY AND ALLEY APRON SECTIONS**

**STANDARD No. 500**

REVISION	DESCRIPTION	MARK	DATE	APPROVED

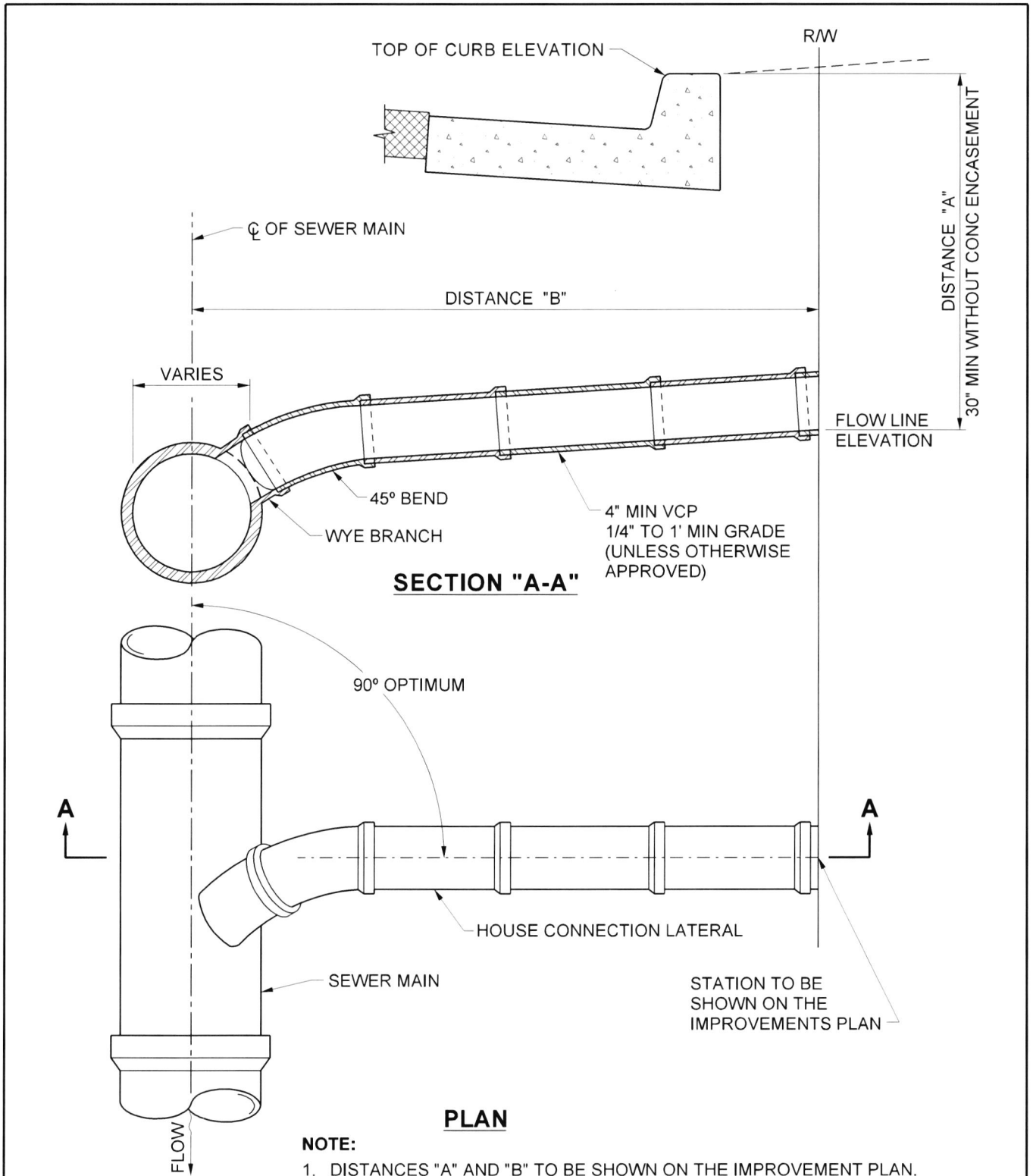

NOT TO SCALE

PREPARED UNDER THE SUPERVISION OF:

*Mark Lancaster*  
 DIRECTOR OF TRANSPORTATION  
 MARK LANCASTER, P.E.

11/30/22  
 DATE

REVISION	DESCRIPTION	MARK	DATE	APPROVED



COUNTY OF RIVERSIDE

**SEWER  
HOUSE CONNECTION**

**STANDARD No. 600**

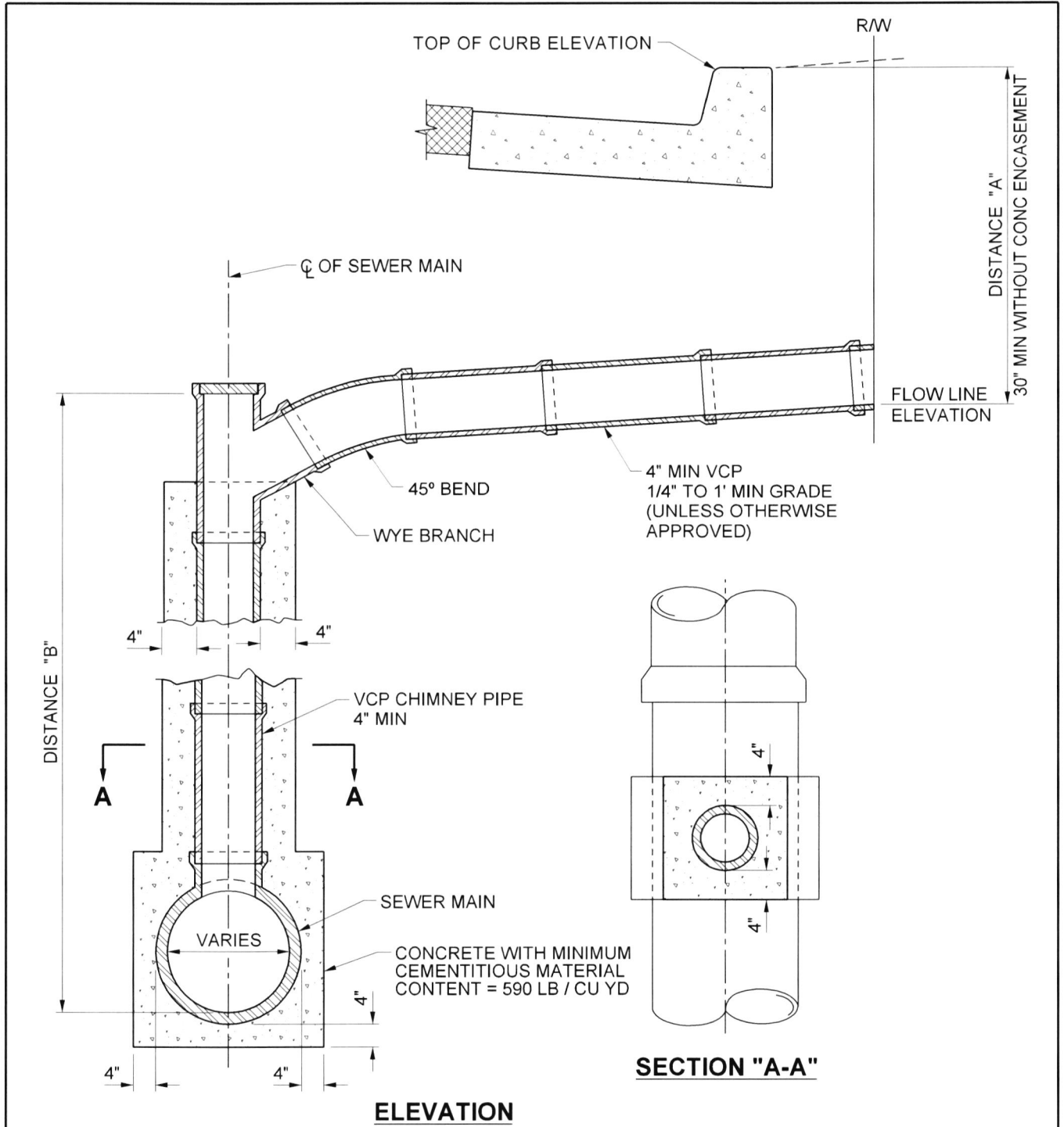

**ELEVATION**

**NOTES:**

1. DISTANCES "A" AND "B" TO BE SHOWN ON THE IMPROVEMENT PLAN.

NOT TO SCALE

PREPARED UNDER THE SUPERVISION OF:

*Mark Lancaster*

11/30/22  
DATE

DIRECTOR OF TRANSPORTATION  
MARK LANCASTER, P.E.

REVISION	DESCRIPTION	MARK	DATE	APPROVED



COUNTY OF RIVERSIDE

**SEWER  
CHIMNEY PIPE**

**STANDARD No. 601**



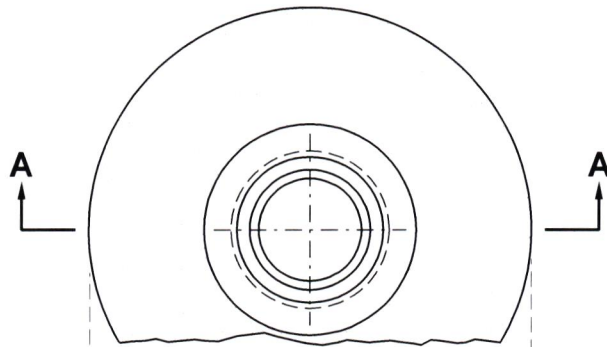

**PLAN**

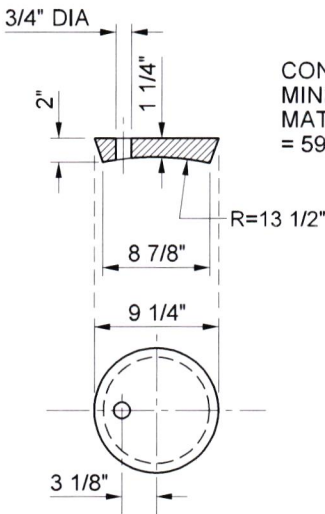
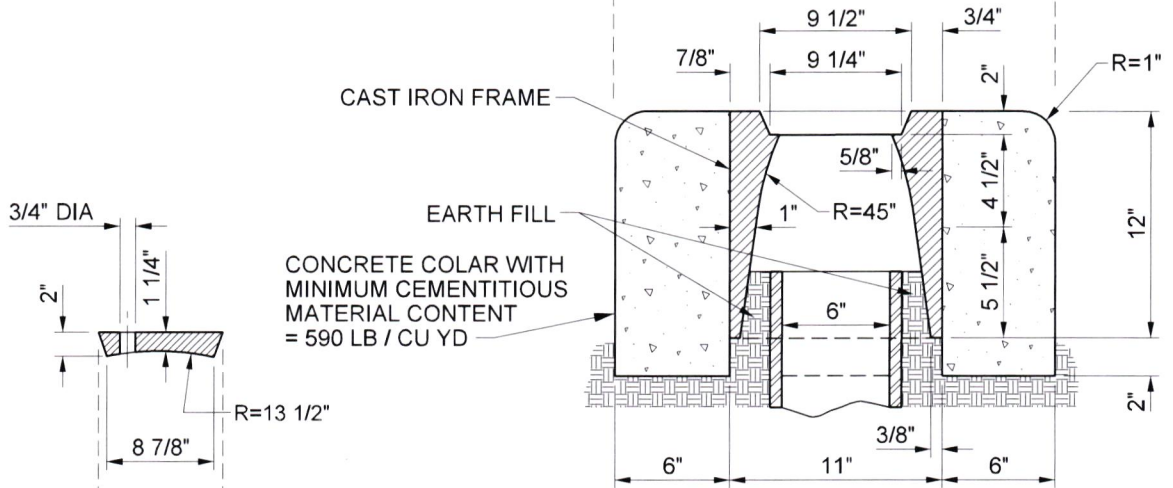

**CAST IRON COVER**

**NOTE:**

1. MINIMUM WEIGHT OF CAST IRON FRAME AND COVER --- 90 POUNDS.

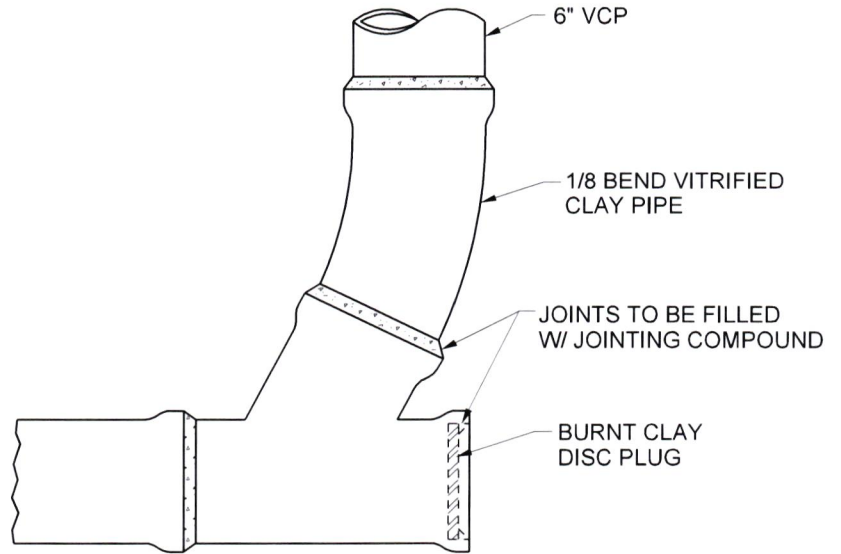

**SECTION "A-A"**

NOT TO SCALE

PREPARED UNDER THE SUPERVISION OF:

*Mark Lancaster*  
 DIRECTOR OF TRANSPORTATION  
 MARK LANCASTER, P.E.

11/30/22  
 DATE

REVISION	DESCRIPTION	MARK	DATE	APPROVED



COUNTY OF RIVERSIDE

**SEWER  
 CLEANOUT**

**STANDARD No. 603**

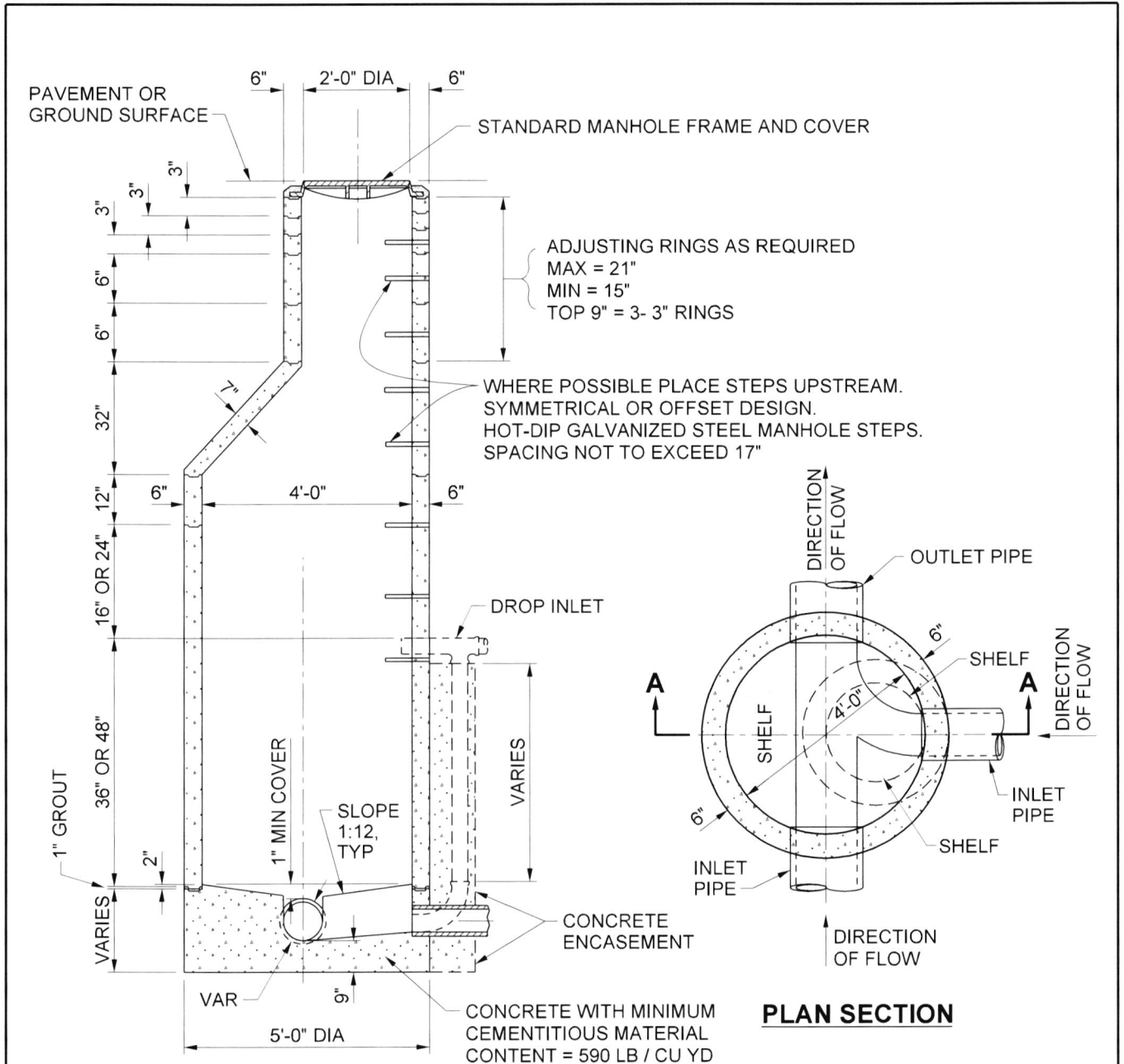

**NOTE:**  
CHANNELS OF MANHOLE BOTTOMS TO BE FORMED IN CONCRETE, AND SIDE INLETS TO HAVE CHANNELS CURVED IN THE DIRECTION OF FLOW.

NOT TO SCALE

PREPARED UNDER THE SUPERVISION OF:

*Mark Lancaster*  
DIRECTOR OF TRANSPORTATION  
MARK LANCASTER, P.E.

11/30/22  
DATE

REVISION	DESCRIPTION	MARK	DATE	APPROVED



COUNTY OF RIVERSIDE

**PRE-CAST  
CONCRETE MANHOLE  
(ECCENTRIC)**

STANDARD No. 606

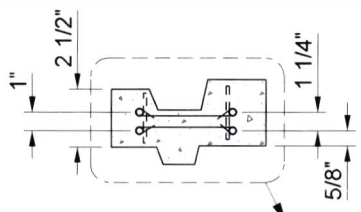

**24" x 2 1/2" GRADE RING**

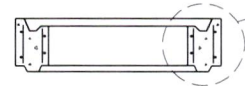

**24" x 6" GRADE RING**

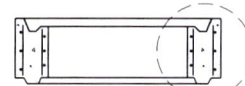

**24" x 8" GRADE RING**

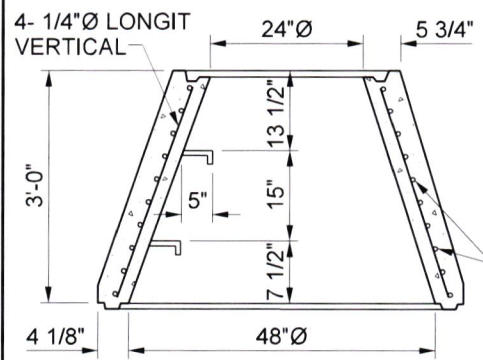

**48" x 24" CONCENTRIC CONE**

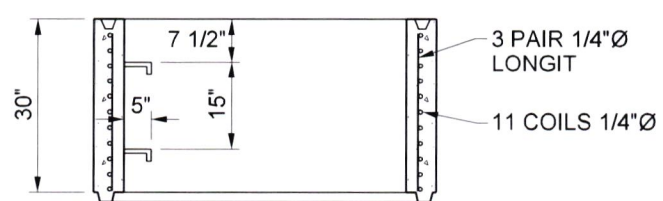

**48" x 30" MANHOLE PIPE**

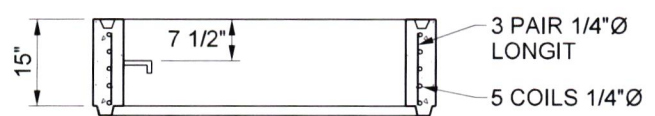

**48" x 15" MANHOLE PIPE**

**NOTE:**  
CONCRETE MINIMUM  
CEMENTITIOUS MATERIAL  
CONTENT = 590 LB / CU YD.

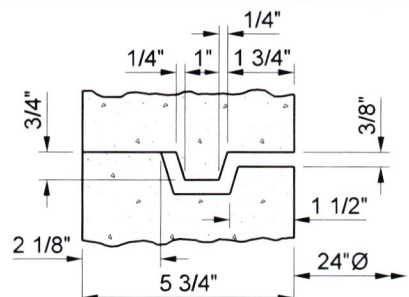
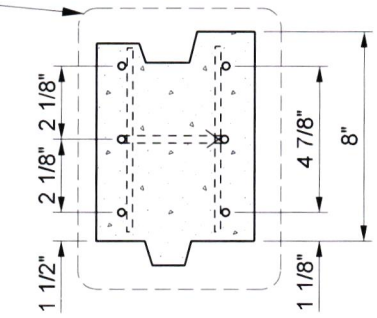
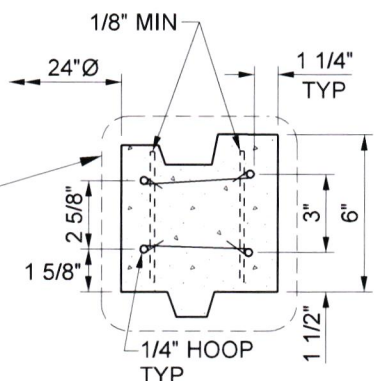

**JOINT DETAIL "A"**

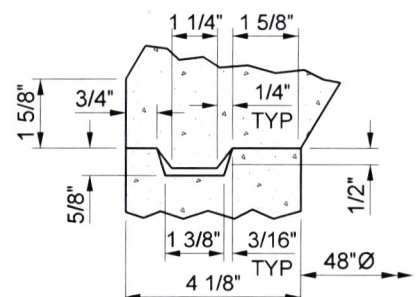

**JOINT DETAIL "B"**

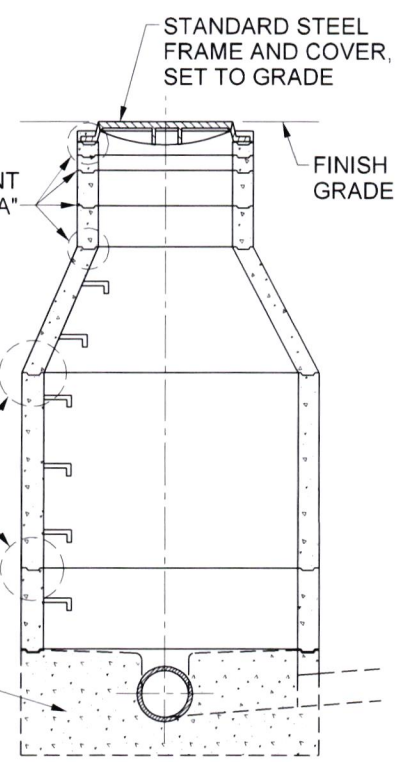

**TYPICAL SECTION**

NOTE: REINFORCEMENT SHOWN IS TYPICAL; ALTERNATE SYSTEMS SUBJECT TO APPROVAL.

NOT TO SCALE

PREPARED UNDER THE SUPERVISION OF:

*Mark Lancaster*

11/30/22  
DATE

DIRECTOR OF TRANSPORTATION  
MARK LANCASTER, P.E.



COUNTY OF RIVERSIDE

**PRE-CAST  
CONCRETE MANHOLE  
(CONCENTRIC)**

**STANDARD No. 607**

REVISION	DESCRIPTION	MARK	DATE	APPROVED

SLIP RESISTANT  
2" x 1" DIAMOND  
MAT, 1/8" DEEP

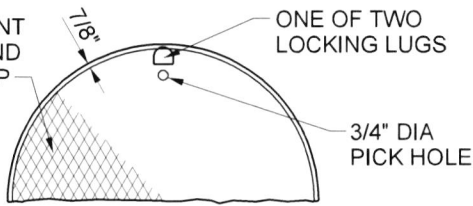

**PLAN  
TOP OF COVER**

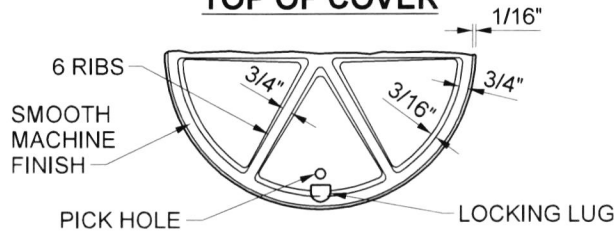

**PLAN  
BOTTOM OF COVER**



**PLAN  
PORTION OF FRAME**

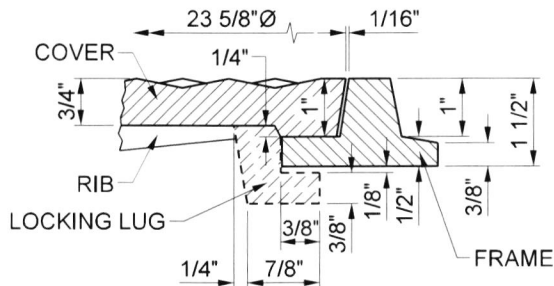

**DETAIL "A"**

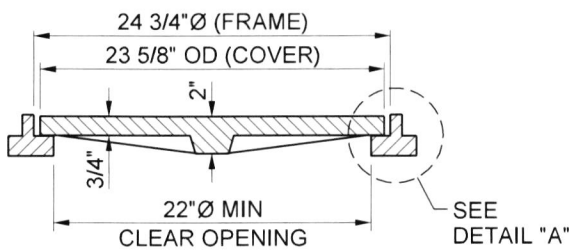

**SECTION - FRAME AND COVER  
PARKWAY**

TOTAL WEIGHT - APPROX 130 LBS.  
ALL METAL TO BE HOT-DIP GALVANIZED.

NOT TO SCALE

PREPARED UNDER THE SUPERVISION OF:

*Mark Lancaster*  
DIRECTOR OF TRANSPORTATION  
MARK LANCASTER, P.E.

11/30/22  
DATE

REVISION	DESCRIPTION	MARK	DATE	APPROVED



COUNTY OF RIVERSIDE

**MANHOLE FRAMES  
AND COVERS**

STANDARD No. 608

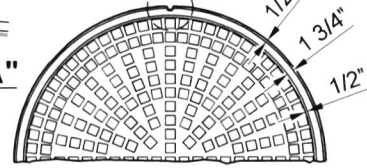
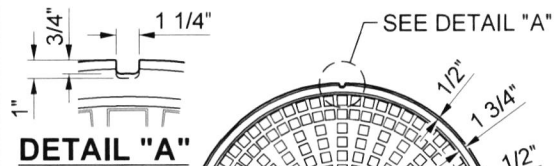

**PLAN  
BOTTOM OF COVER**

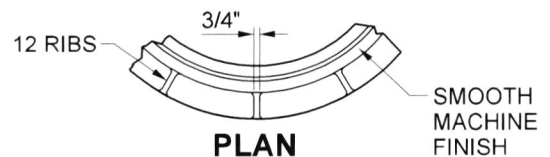

**PLAN  
PORTION OF FRAME**

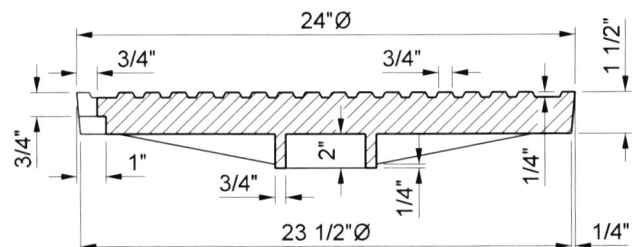
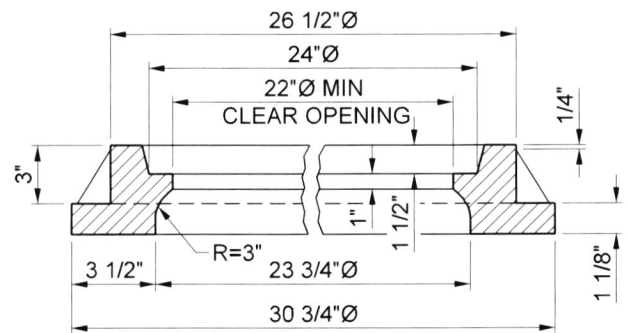

**SECTION - COVER  
ROADWAY**

TOTAL WEIGHT - APPROX 380 LBS.  
ALL METAL TO BE HOT-DIP GALVANIZED.

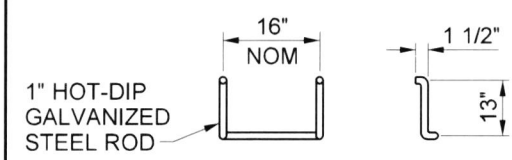
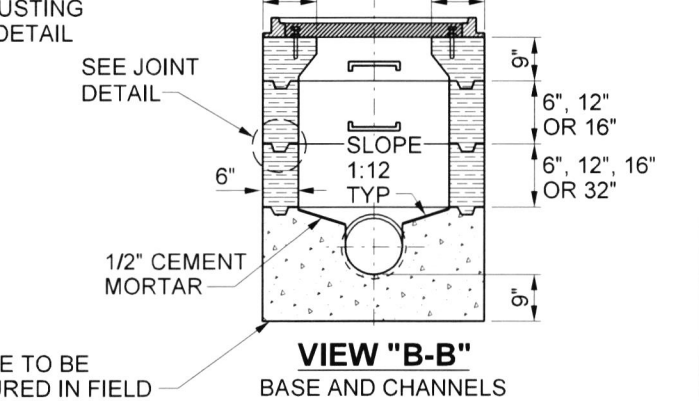
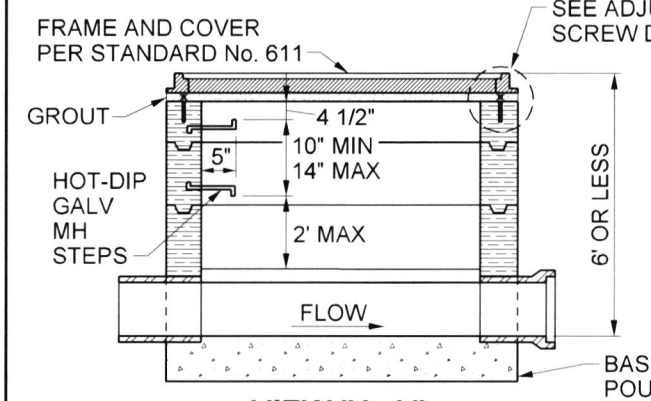
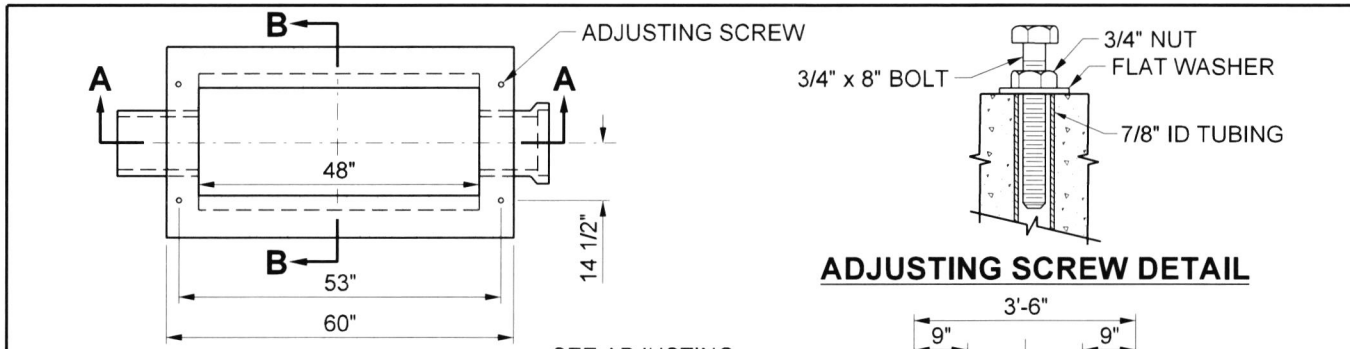

**DROP STEP DETAIL**

PRECAST OR GROUT STEPS INTO PLACE AS SHOWN IN SECTIONAL ELEVATION.

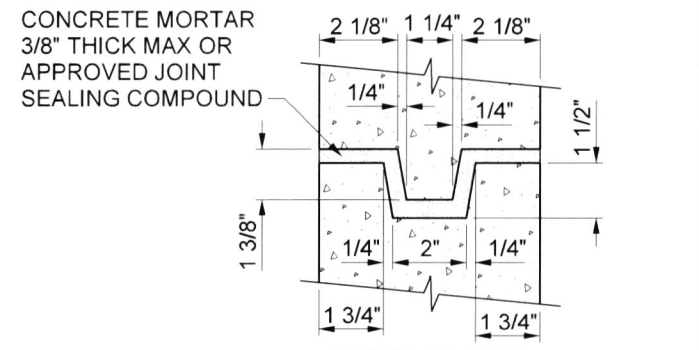

**JOINT DETAIL**

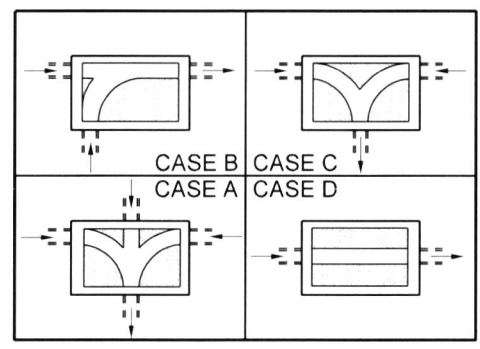

**ALTERNATE PLACEMENT OF CHANNELS**

**NOTES:**

1. CONCRETE FOR ALL PRECAST UNITS SHALL BE THOROUGHLY VIBRATED IN FORMS. IT SHALL BE CURED ACCORDING TO APPROVED PRACTICE EITHER BY STEAM, SPRINKLING, MEMBRANE SOLUTION, OR A COMBINATION OF THESE. IT SHALL DEVELOP 3500 PSI OR GREATER IN 28 DAYS. CONCRETE WITH MINIMUM CEMENTITIOUS MATERIAL CONTENT = 590 LB / CU YD.
2. CONCRETE MINIMUM CEMENTITIOUS MATERIAL CONTENT = 590 LB / CU YD. ALL FIELD Poured CONCRETE SHALL BE ALLOWED TO SET 24 HOURS BEFORE PLACING PRECAST UNITS.
3. ALL PRECAST UNITS SHALL BE REINFORCED FOR HS-20 BRIDGE LOADING.
4. TO BE USED FOR DEPTHS LESS THAN 5' FROM MANHOLE TOP TO SEWER PIPE SHELF.

NOT TO SCALE

PREPARED UNDER THE SUPERVISION OF:

*Mark Lancaster*  
 DIRECTOR OF TRANSPORTATION  
 MARK LANCASTER, P.E.  
 DATE 11/30/22

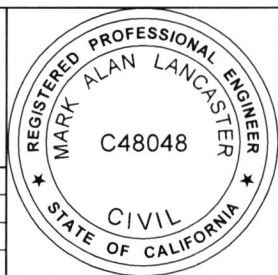

COUNTY OF RIVERSIDE

**PRECAST RECTANGULAR SHALLOW MANHOLE**

**STANDARD No. 610**

REVISION	DESCRIPTION	MARK	DATE	APPROVED

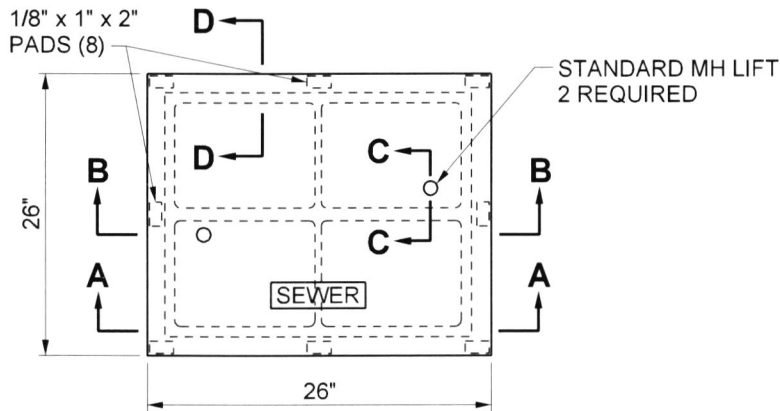

**MANHOLE COVER**

(2 COVERS REQUIRED PER FRAME)

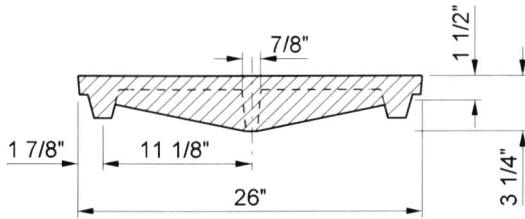

**SECTION "A-A"**

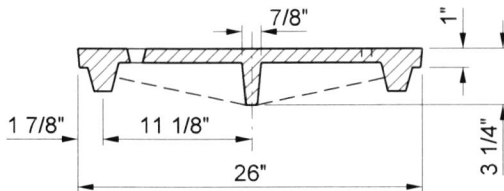

**SECTION "B-B"**

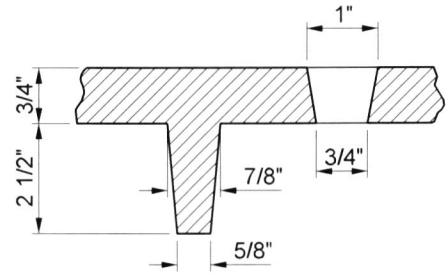

**SECTION "C-C"**

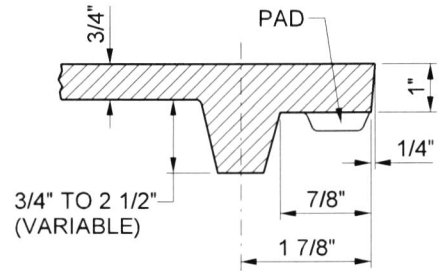

**SECTION "D-D"**

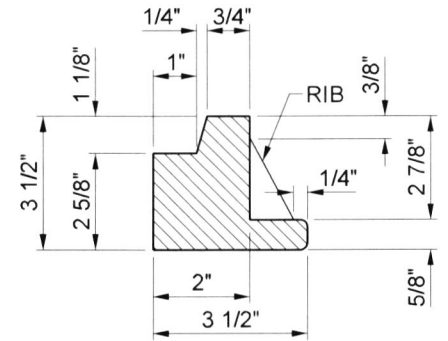

**SECTION "E-E"**

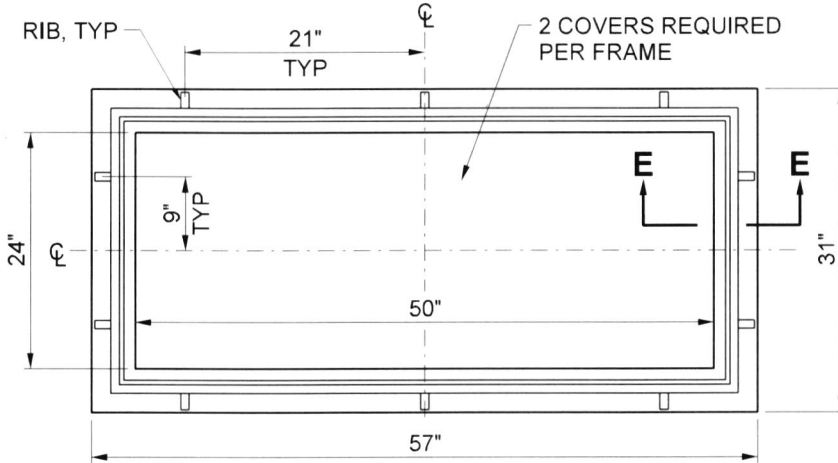

**MANHOLE FRAME**

**NOTE:**

EXPOSED METAL & COVER TO BE OT-DIP GALVANIZED AFTER FABRICATION.

NOT TO SCALE

PREPARED UNDER THE SUPERVISION OF:

*Mark Lancaster*

11/30/22  
DATE

DIRECTOR OF TRANSPORTATION  
MARK LANCASTER, P.E.



COUNTY OF RIVERSIDE

**RECTANGULAR  
MANHOLE  
FRAME AND COVER**

STANDARD No. 611

REVISION	DESCRIPTION	MARK	DATE	APPROVED

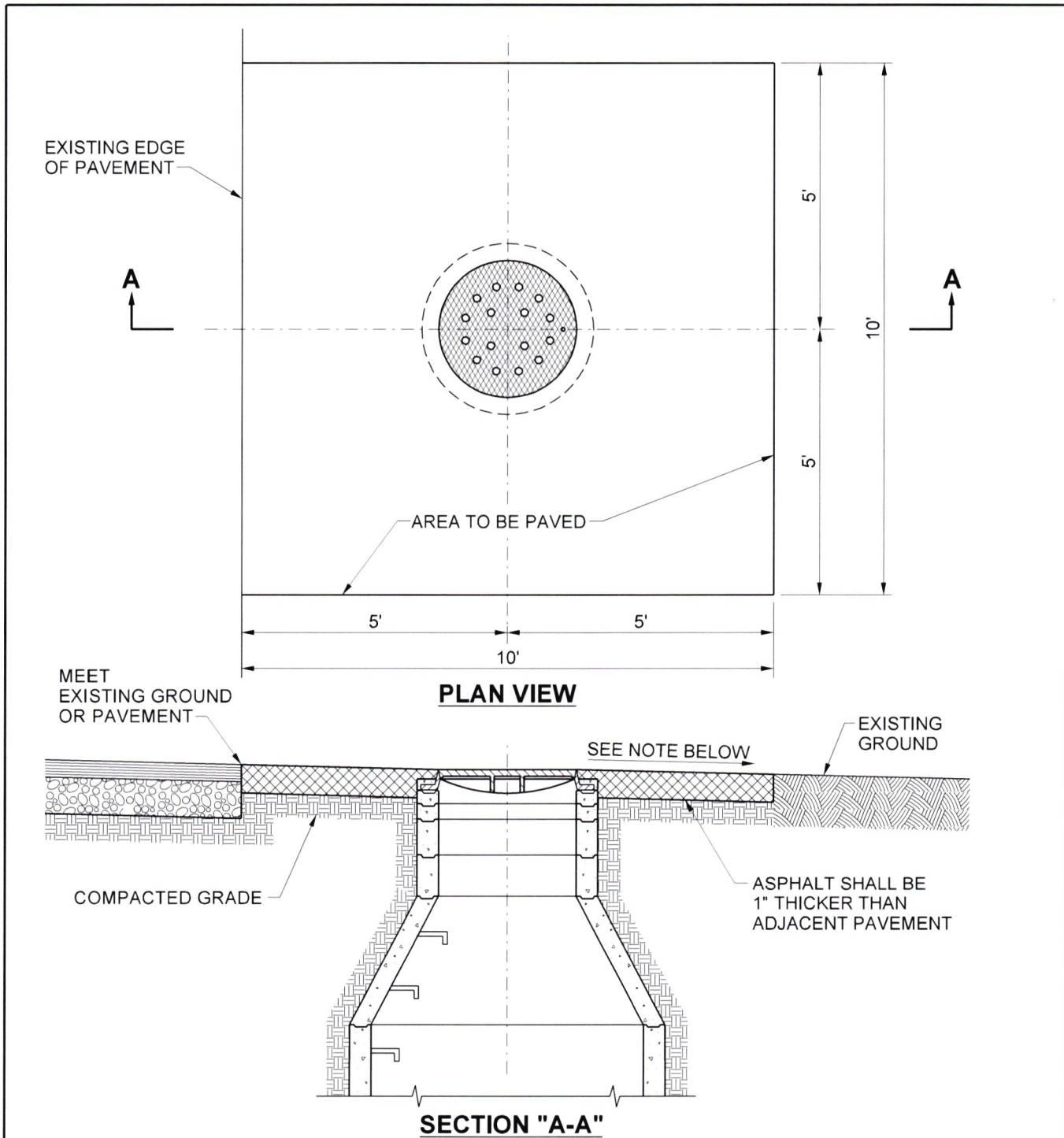

**NOTE:**  
 SLOPE WILL CONFORM WITH COUNTY OF RIVERSIDE ROAD IMPROVEMENT STANDARDS AND SPECIFICATIONS, OR MEET EXISTING CONDITIONS AS DIRECTED BY THE COUNTY ENGINEER.

NOT TO SCALE

PREPARED UNDER THE SUPERVISION OF:

*Mark Lancaster*  
 DIRECTOR OF TRANSPORTATION  
 MARK LANCASTER, P.E.  
 11/30/22  
 DATE



COUNTY OF RIVERSIDE

**PAVING DETAIL  
 AROUND MANHOLE  
 IN UNPAVED AREA**

**STANDARD No. 612**

REVISION	DESCRIPTION	MARK	DATE	APPROVED

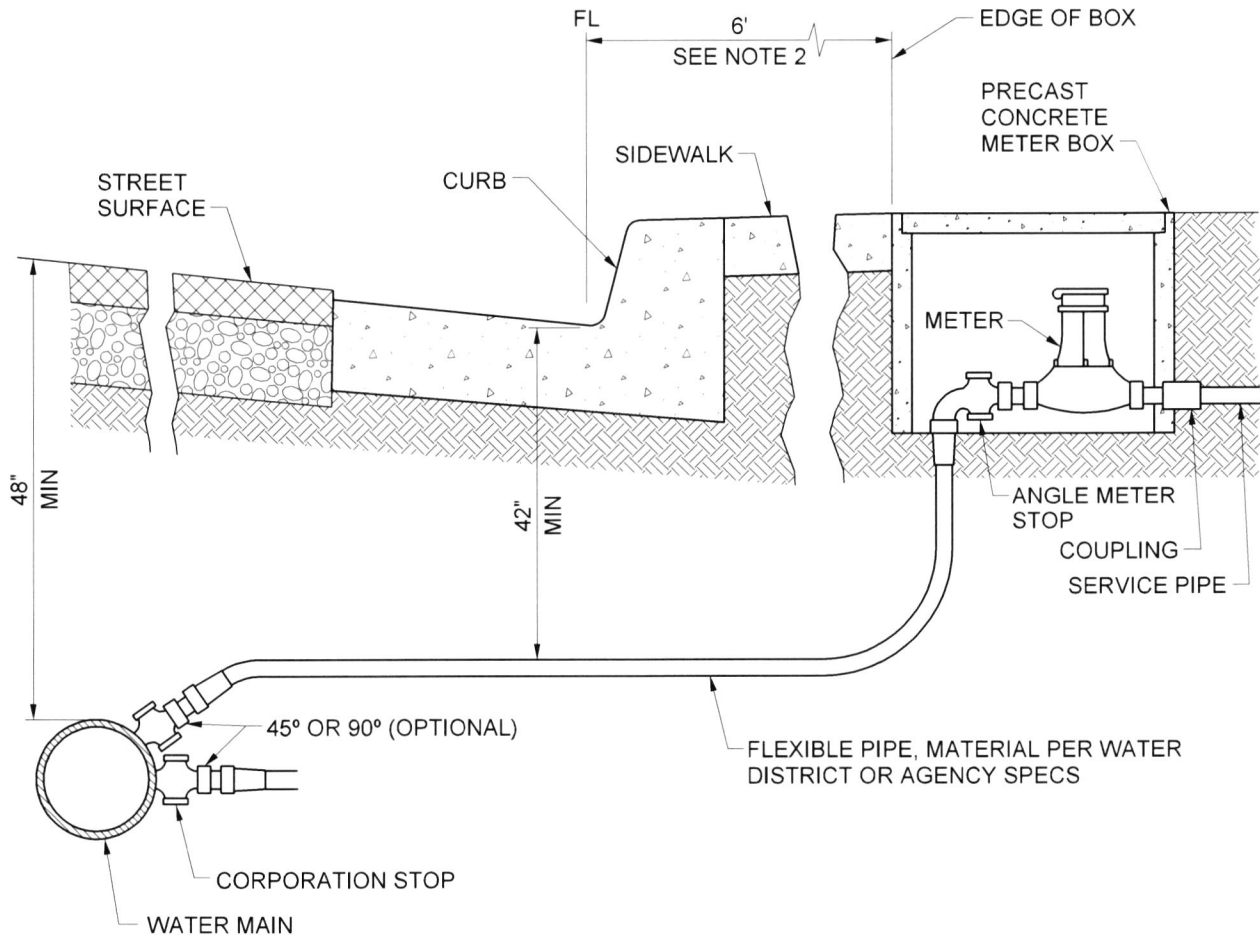

**NOTES:**

1. ALL LOT SERVICE LATERALS TO BE INSTALLED PRIOR TO PAVING OF STREET, INCLUDING FIRE SPRINKLER PREVENTION SERVICE.
2. 1.5' WHEN SIDEWALK IS ADJACENT TO RW.
3. WHEN ABUTTING SOIL HAS A HIGH SULFATE CONTENT, USE A MODIFIED CONCRETE MIX AND PLACE 6" MIN CLASS 2 AGGREGATE BASE AND 6 MIL PLASTIC SHEETING UNDER AND AROUND ALL SIDES OF CONCRETE IMPROVEMENTS. FOR EXPANSIVE SOIL, PLACE 6" MIN CLASS 2 AGGREGATE BASE UNDER CONCRETE IMPROVEMENTS AS DIRECTED BY THE ENGINEER. SEE SPECIFICATIONS SECTIONS 16.03 & 16.04 AND STANDARD No. 401 FOR REFERENCE.

NOT TO SCALE

PREPARED UNDER THE SUPERVISION OF:

*Mark Lancaster* 11/30/22  
 DIRECTOR OF TRANSPORTATION DATE  
 MARK LANCASTER, P.E.



COUNTY OF RIVERSIDE

**WATER METER  
 INSTALLATION**

**STANDARD No. 700**

REVISION	DESCRIPTION	MARK	DATE	APPROVED



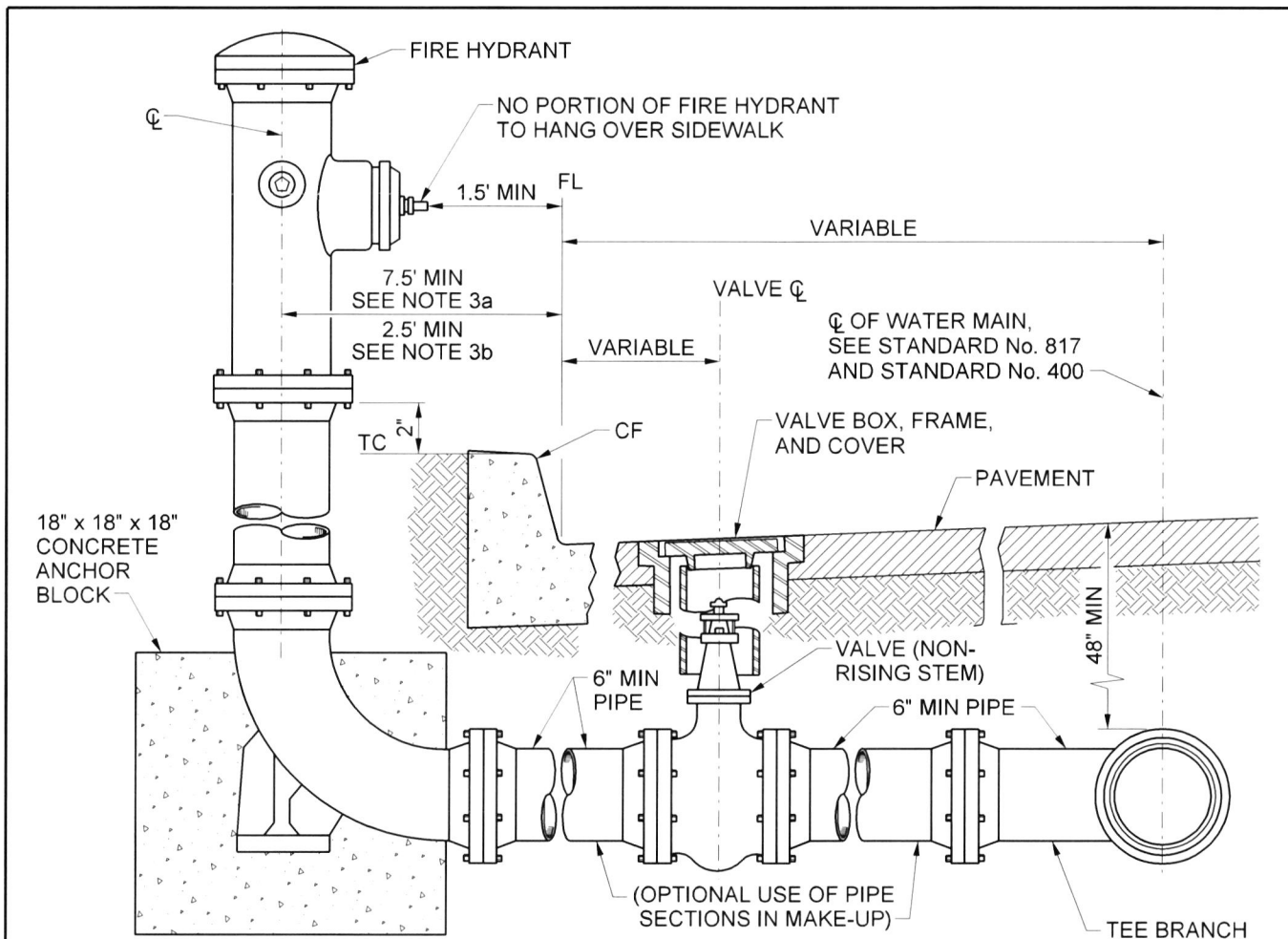

**NOTES:**

1. FIRE HYDRANT TO BE AS APPROVED BY SERVING AGENCY.
2. HYDRANTS WILL BE INSTALLED IN ACCORDANCE WITH ORDINANCE 460.
3. FIRE HYDRANT SHALL BE PLACED:
  - a) 7.5 FEET MIN FROM CURB FLOW LINE TO THE CENTERLINE OF THE FIRE HYDRANT WHEN THE SIDEWALK IS ADJACENT TO THE CURB AND 6 FEET WIDE FROM THE CURB FLOW LINE.
  - b) 2.5 FEET MIN FROM CURB FLOW LINE TO THE CENTERLINE OF THE FIRE HYDRANT WHEN THE SIDEWALK IS ADJACENT TO THE RIGHT OF WAY OR MEANDERING, AND WHEN NO SIDEWALK IS PROPOSED OR EXISTING, AND CURB AND GUTTER IS EXISTING. KEEP AN UNOBSTRUCTED DISTANCE OF 1.5 FEET FROM CURB FLOW LINE TO THE NEAREST PORTION OF THE FIRE HYDRANT.
4. FIRE HYDRANT SHALL NOT BE PLACED WITHIN THE CORNER CUT BACK AT ANY TIME.
5. FIRE HYDRANT ORIENTATION: (REV 1)
  - a) SINGLE OUTLET HYDRANTS SHALL BE INSTALLED WITH THE OUTLET FACING THE CURB AND AT RIGHT ANGLES TO THE CURB.
  - b) DOUBLE OUTLET HYDRANTS SHALL BE INSTALLED WITH THE OUTLETS FACING THE CURB AND AT FORTY-FIVE (45) DEGREES TO THE CURB.
  - c) TRIPLE OUTLET HYDRANTS SHALL BE INSTALLED WITH THE LARGEST OUTLET FACING AT RIGHT ANGLES TO THE CURB.
6. WHEN ABUTTING SOIL HAS A HIGH SULFATE CONTENT, USE A MODIFIED CONCRETE MIX AND PLACE 6" MIN CLASS 2 AGGREGATE BASE AND 6 MIL PLASTIC SHEETING UNDER AND AROUND ALL SIDES OF CONCRETE IMPROVEMENTS. FOR EXPANSIVE SOIL, PLACE 6" MIN CLASS 2 AGGREGATE BASE UNDER CONCRETE IMPROVEMENTS AS DIRECTED BY THE ENGINEER. SEE SPECIFICATIONS SECTIONS 16.03 & 16.04 AND STANDARD No. 401 FOR REFERENCE.

NOT TO SCALE

PREPARED UNDER THE SUPERVISION OF:

*Mark Lancaster* 11/30/22  
 DIRECTOR OF TRANSPORTATION DATE  
 MARK LANCASTER, P.E.

REVISION	DESCRIPTION	MARK	DATE	APPROVED



COUNTY OF RIVERSIDE

**FIRE HYDRANT  
 INSTALLATION**

**STANDARD No. 701**

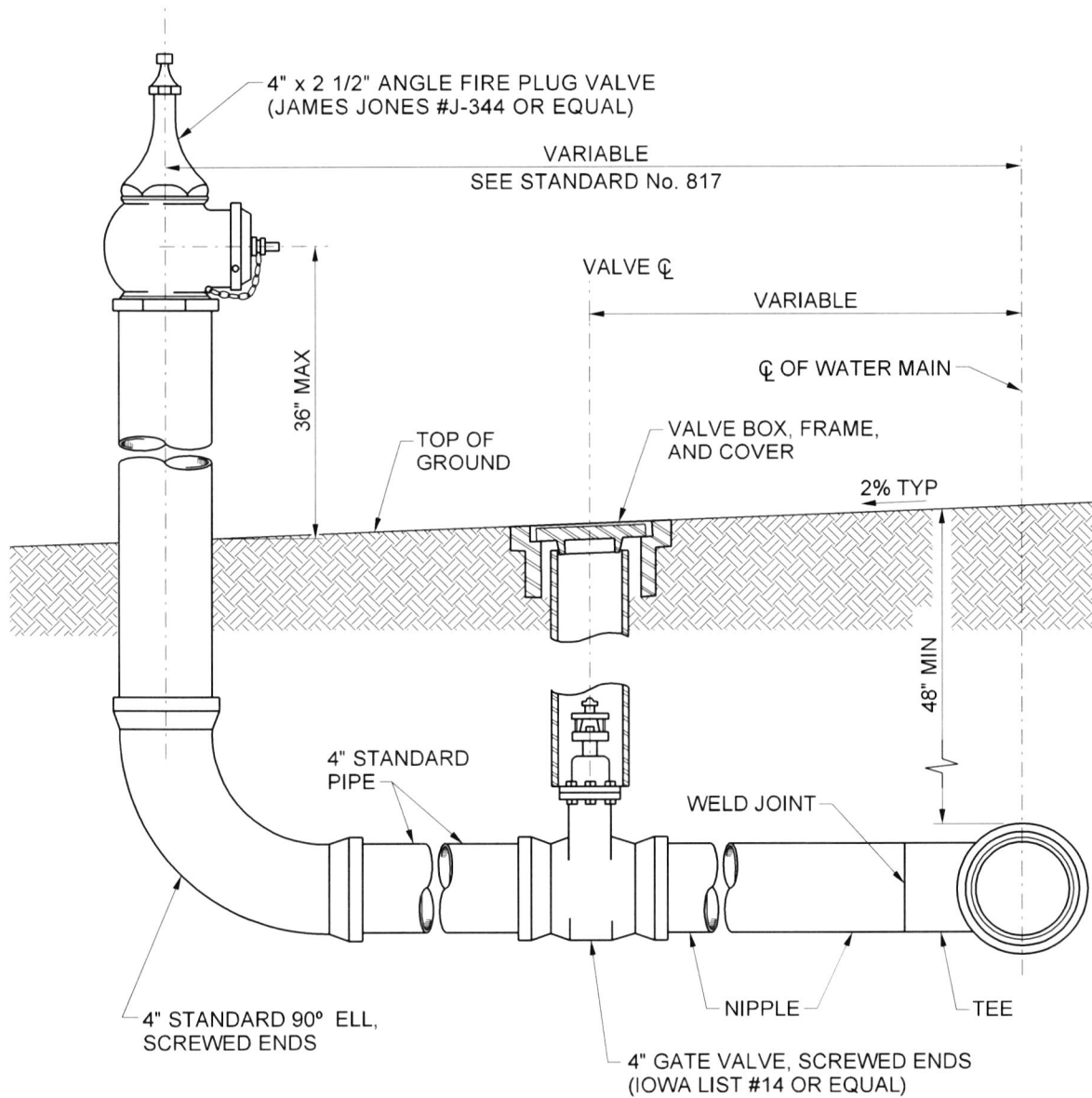

**NOTE:**

HYDRANTS TO BE INSTALLED IN ACCORDANCE WITH ORDINANCES 460 AND 787.4.

NOT TO SCALE

PREPARED UNDER THE SUPERVISION OF:

*Mark Lancaster*

11/30/22  
DATE

DIRECTOR OF TRANSPORTATION  
MARK LANCASTER, P.E.

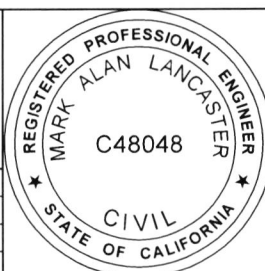

COUNTY OF RIVERSIDE

**FIRE HYDRANT  
INSTALLATION  
(ALTERNATE)**

**STANDARD No. 702**

REVISION	DESCRIPTION	MARK	DATE	APPROVED

3/8" RADIUS NOTCH

A

A

1/2 PLAN OF COVER  
HOT-DIP GALVANIZED STEEL

1/2 PLAN OF FRAME  
HOT-DIP GALVANIZED STEEL

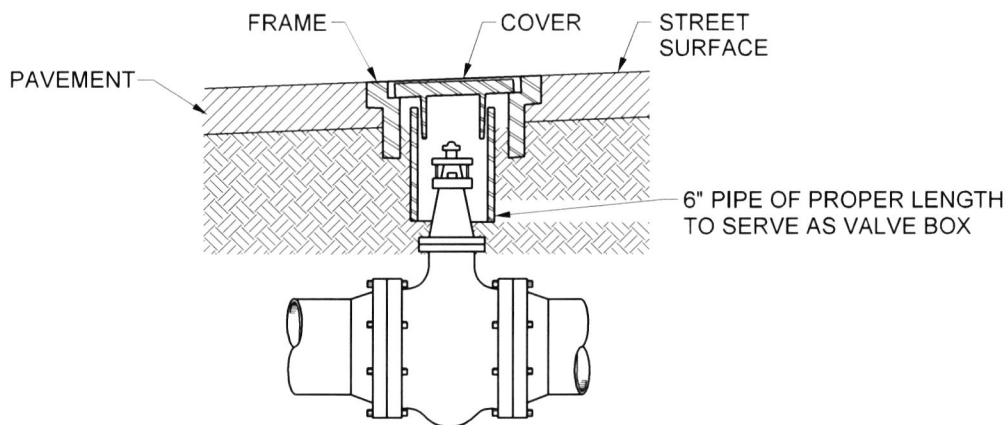
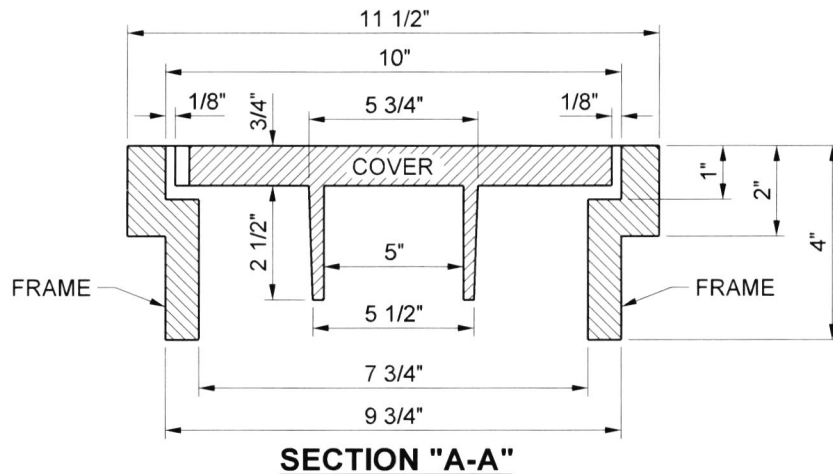

NOT TO SCALE

PREPARED UNDER THE SUPERVISION OF:

*Mark Lancaster*

11/30/22  
DATE

DIRECTOR OF TRANSPORTATION  
MARK LANCASTER, P.E.



COUNTY OF RIVERSIDE

**VALVE BOX, FRAME  
AND COVER**

**STANDARD No. 703**

REVISION	DESCRIPTION	MARK	DATE	APPROVED

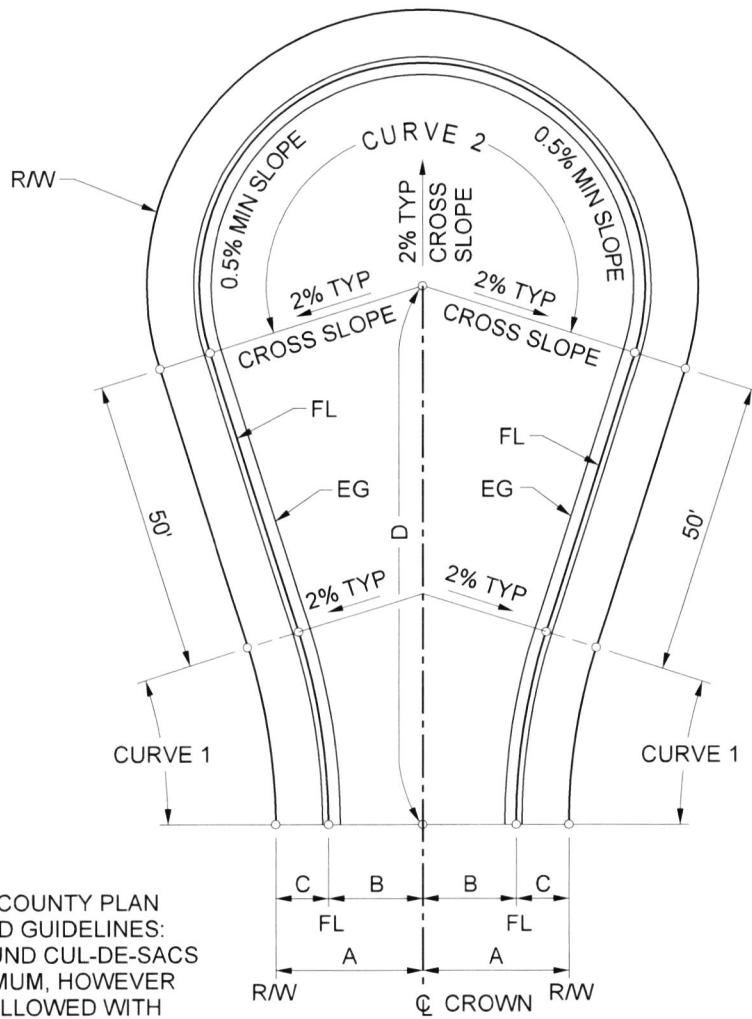

NOTE:  
 REQUIREMENT PER COUNTY PLAN  
 CHECK POLICIES AND GUIDELINES:  
 MINIMUM FALL AROUND CUL-DE-SACS  
 SHALL BE 1.0% MINIMUM, HOWEVER  
 A 0.5% MINIMUM IS ALLOWED WITH  
 PRIOR APPROVAL.

RW	A	B	C	D	CURVE 1				CURVE 2					
					△	FL		RW		△	FL		RW	
						R	L	R	L		R	L	R	L
50'	25'	16'	9'	92.11'	17°36' 01"	109'	33.48'	100'	30.72'	215°12' 02"	38'	142.73'	47'	176.53'
56'	28'	18'	10'	89.55'	16°18' 41"	110'	31.31'	100'	28.47'	212°37' 22"	38'	141.02'	48'	178.12'
60'	30'	20'	10'	86.63'	15°00' 38"	110'	28.82'	100'	26.20'	210°01' 17"	38'	139.29'	48'	175.95'
66'	33'	22'	11'	83.74'	13°38' 40"	111'	26.44'	100'	23.82'	207°17' 21"	38'	137.48'	49'	177.28'
74'	37'	22'	15'	84.50'	13°34' 05"	115'	27.23'	100'	23.68'	207°08' 10"	38'	137.38'	53'	191.61'
78'	39'	28'	11'	95.39'	17°12' 31"	111'	33.33'	100'	30.03'	214°25' 02"	50'	187.11'	61'	228.28'
SCHEDULE "H"					CURVE 1- EDGE OF AGGREGATE BASE				CURVE 2- EDGE OF AGGREGATE BASE					
-	-	12'		90.00	21°02' 30"	82.69'	30.37'	-	-	222°04' 59"	38'	147.29'	-	-

NOT TO SCALE

PREPARED UNDER THE SUPERVISION OF:

*Mark Lancaster*  
 DIRECTOR OF TRANSPORTATION  
 MARK LANCASTER, P.E.

11/30/22  
 DATE

REVISION DESCRIPTION	MARK	DATE	APPROVED



COUNTY OF RIVERSIDE

**CUL-DE-SAC**

**STANDARD No. 800**

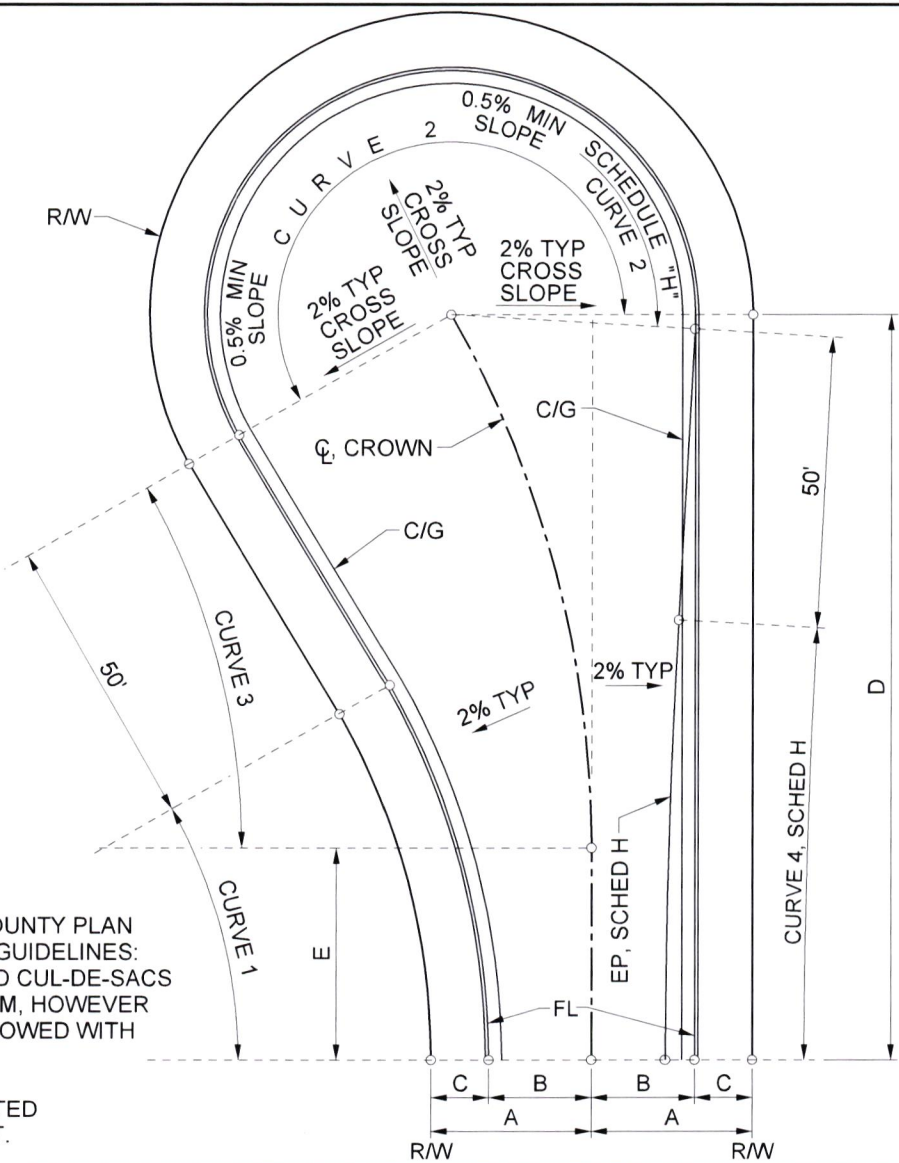

NOTE:  
 REQUIREMENT PER COUNTY PLAN  
 CHECK POLICIES AND GUIDELINES:  
 MINIMUM FALL AROUND CUL-DE-SACS  
 SHALL BE 1.0% MINIMUM, HOWEVER  
 A 0.5% MINIMUM IS ALLOWED WITH  
 PRIOR APPROVAL.

OFFSET MAY BE LOCATED  
 EITHER LEFT OR RIGHT.

NOT TO SCALE

						CURVE 1				CURVE 2				CURVE 3				
RW	A	B	C	D	E	Δ	FL		RW		Δ	FL		RW		CROWN		
							R	L	R	L		R	L	R	L			
50'	25'	16'	9'	116.19'	32.00'	29°39' 31"	109'	56.42'	100'	51.76'	209°39' 31"	38'	139.05'	47'	171.98'	29°39' 31"	170.14'	88.07'
56'	28'	18'	10'	112.87'	31.44'	27°35' 48"	110'	52.98'	100'	48.17'	207°35' 48"	38'	137.68'	48'	173.92'	27°35' 47"	175.79'	84.67'
60'	30'	20'	10'	108.90'	29.45'	25°31' 48"	110'	49.01'	100'	44.56'	205°31' 48"	38'	136.31'	48'	172.18'	25°31' 48"	184.35'	82.14'
66'	33'	22'	11'	104.94'	27.47'	23°20' 19"	111'	45.21'	100'	40.73'	203°20' 19"	38'	134.86'	49'	173.90'	23°20' 19"	195.54'	79.65'
74'	37'	22'	15'	106.15'	28.08'	23°09' 45"	115'	46.49'	100'	40.43'	203°09' 45"	38'	134.74'	53'	187.93'	23°09' 45"	198.48'	80.24'
78'	39'	28'	11'	121.38'	35.69'	28°47' 56"	111'	55.79'	100'	50.26'	208°47' 56"	50'	182.21'	61'	222.30'	28°47' 56"	177.87'	89.41'
SCHEDULE "H"						CURVE 1 - EDGE OF AB				CURVE 2 - EDGE OF AB				CURVE 4 - EDGE OF AB				
-	-	12'	-	113.58'	31.79'	31°24' 45"	98.05'	55.47'	-	-	215°36' 50"	38'	143.00'	-	-	4°12' 05"	831.70'	60.99'

PREPARED UNDER THE SUPERVISION OF:

*Mark Lancaster*  
 DIRECTOR OF TRANSPORTATION  
 MARK LANCASTER, P.E.  
 11/30/22  
 DATE



COUNTY OF RIVERSIDE

**OFFSET  
 CUL-DE-SAC**

**STANDARD No. 800A**

REVISION	DESCRIPTION	MARK	DATE	APPROVED

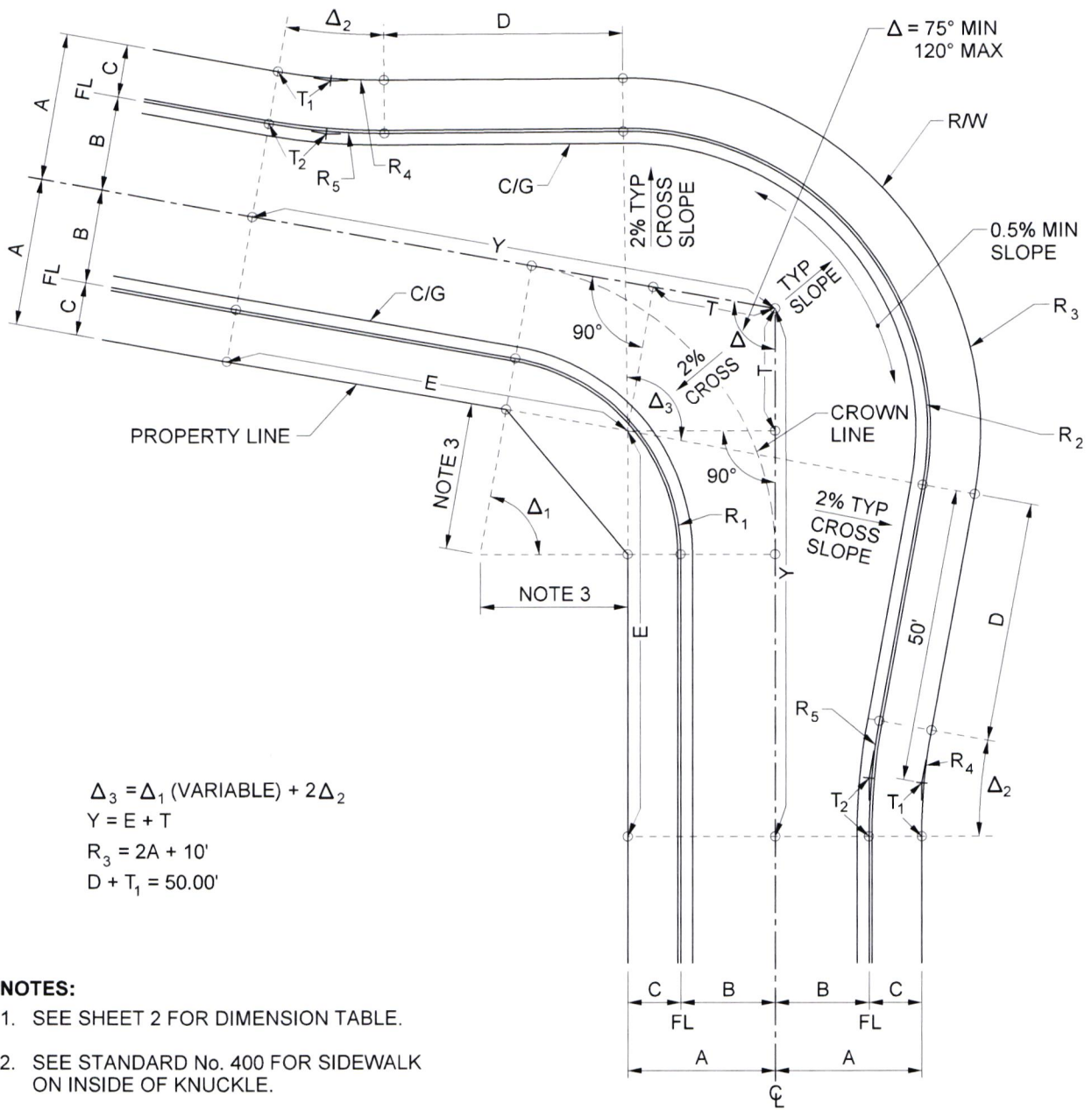

**NOTES:**

1. SEE SHEET 2 FOR DIMENSION TABLE.
2. SEE STANDARD No. 400 FOR SIDEWALK ON INSIDE OF KNUCKLE.
3. 25' REGARDLESS OF RW WIDTH.

NOT TO SCALE

PREPARED UNDER THE SUPERVISION OF:

*Mark Lancaster*  
 DIRECTOR OF TRANSPORTATION  
 MARK LANCASTER, P.E.

11/30/22  
 DATE



COUNTY OF RIVERSIDE

**KNUCKLE**

STANDARD No. 801 (1 OF 2)

REVISION	DESCRIPTION	MARK	DATE	APPROVED

**KNUCKLE DIMENSION TABLE**

R/W	ROADWAY IMPROVEMENT WIDTH	A	B	C	D	E	R <sub>1</sub>	R <sub>2</sub>	R <sub>3</sub>	Δ <sub>2</sub>	R <sub>4</sub>	T <sub>1</sub>	R <sub>5</sub>	T <sub>2</sub>
50'	32'	25'	16'	9'	40.91'	69.09'	35'	51'	60'	10°23'19"	100'	9.09'	109'	9.91'
56'	36'	28'	18'	10'	40.99'	70.00'	35'	56'	66'	10°17'48"	100'	9.01'	110'	9.91'
60'	40'	30'	20'	10'	41.04'	70.60'	35'	60'	70'	10°14'12"	100'	8.96'	110'	9.85'
66'	44'	33'	22'	11'	41.12'	71.49'	36'	65'	76'	10°08'58"	100'	8.88'	111'	9.86'
74'	44'	37'	22'	15'	41.22'	72.66'	40'	69'	84'	10°02'13"	100'	8.88'	115'	10.10'
78'	56'	39'	28'	11'	41.27'	73.23'	36'	77'	88'	9°58'58"	100'	8.73'	111'	9.69'

NOT TO SCALE

PREPARED UNDER THE SUPERVISION OF:

*Mark Lancaster* 11/30/22  
 DIRECTOR OF TRANSPORTATION DATE  
 MARK LANCASTER, P.E.

REVISION DESCRIPTION	MARK	DATE	APPROVED



COUNTY OF RIVERSIDE

**KNUCKLE**

**STANDARD No. 801 (2 OF 2)**

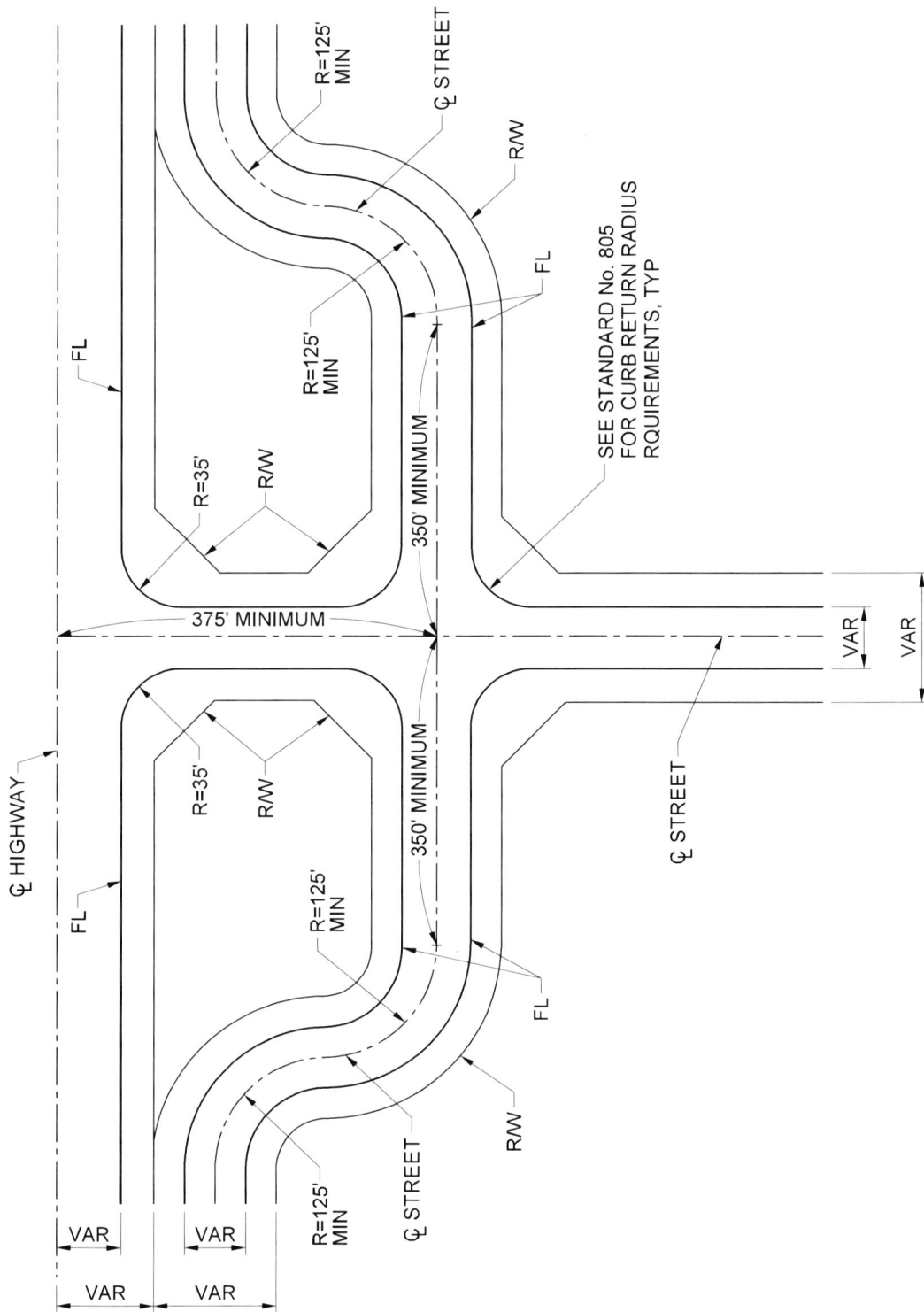

NOT TO SCALE

PREPARED UNDER THE SUPERVISION OF:

*Mark Lancaster*

11/30/22  
DATE

DIRECTOR OF TRANSPORTATION  
MARK LANCASTER, P.E.



COUNTY OF RIVERSIDE

**FRONTAGE ROAD  
INTERSECTION**

**STANDARD No. 802**

REVISION	DESCRIPTION	MARK	DATE	APPROVED



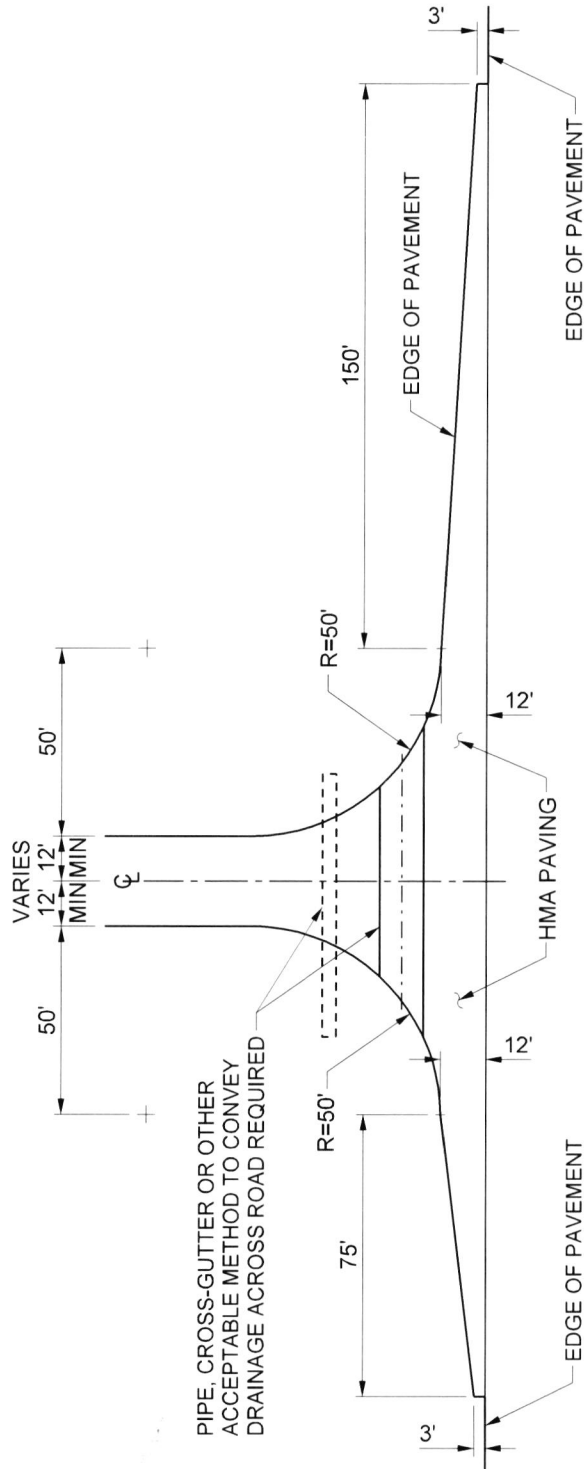

NOT TO SCALE

PREPARED UNDER THE SUPERVISION OF:

*Mark Lancaster*

11/30/22  
DATE

DIRECTOR OF TRANSPORTATION  
MARK LANCASTER, P.E.



COUNTY OF RIVERSIDE

**PRIVATE ROAD  
CONNECTION  
(RURAL AREA)**

STANDARD No. 803

REVISION DESCRIPTION	MARK	DATE	APPROVED

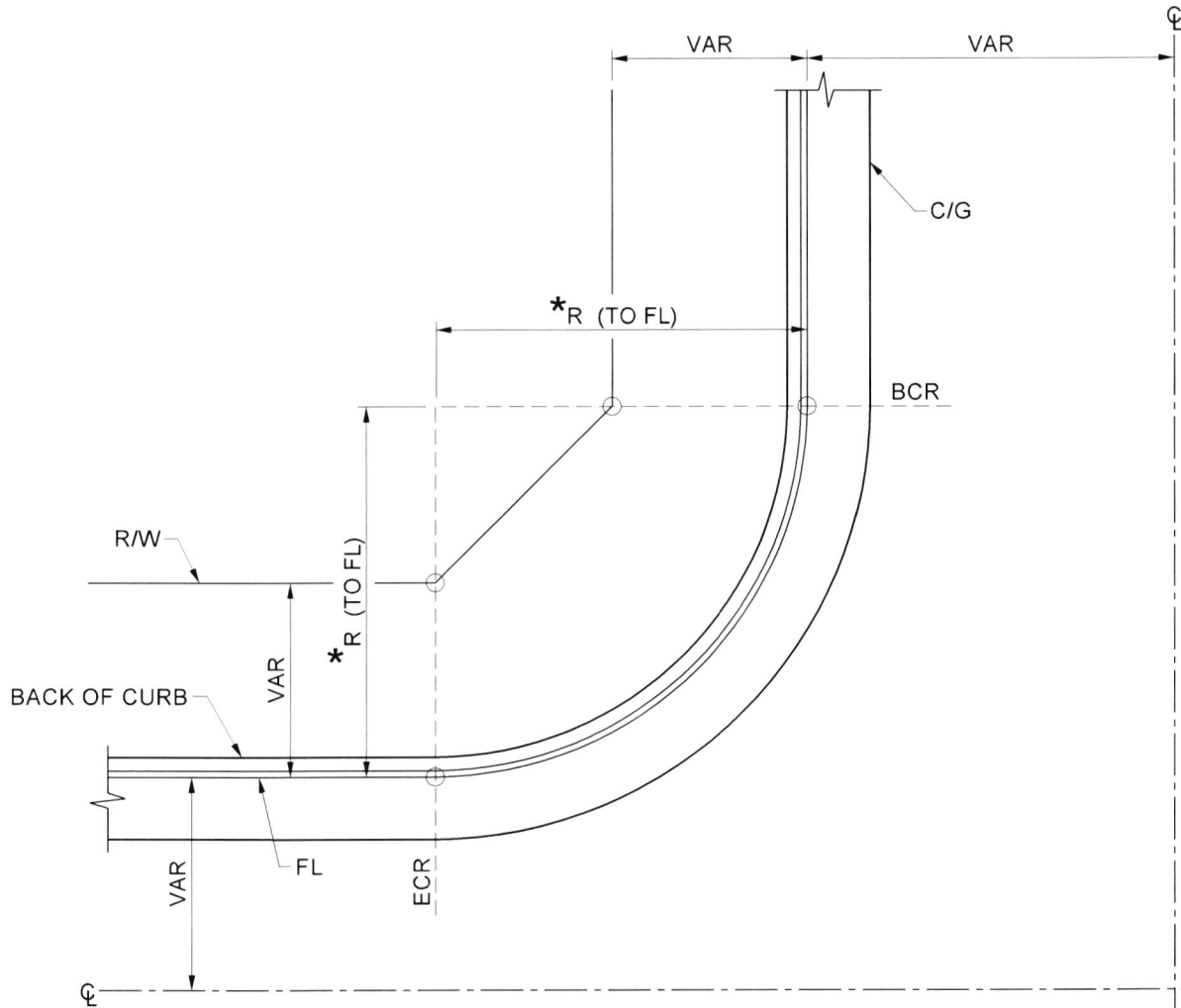

- \* R = 25' IF BOTH STREETS HAVE A ROADBED WIDTH LESS THAN STANDARD No. 111 FULL WIDTH SECTION (INDUSTRIAL COLLECTOR, 78' RW)
- \* R = 35' IF EITHER STREET HAS A ROADBED WIDTH GREATER THAN OR EQUAL TO STANDARD No. 111 FULL WIDTH SECTION (INDUSTRIAL COLLECTOR 78' RW)

**NOTES:**

1. SEE SHEET 2 OF 2 FOR EXTENDED CORNER CUT BACK REQUIREMENTS FOR SCHEDULE A SUBDIVISIONS WITH ENTRY STATEMENTS PER COUNTYWIDE DESIGN GUIDELINES.
2. THE CORNER CUT BACK MAY NEED TO BE SET FURTHER FROM THE CURB RETURN IN ORDER TO MEET DISTANCE REQUIREMENTS FOR CURB RAMPS AND LANDINGS. SEE STD No. 403 - CASE A.

NOT TO SCALE

PREPARED UNDER THE SUPERVISION OF:

*Mark Lancaster* 11/30/22  
 DIRECTOR OF TRANSPORTATION DATE  
 MARK LANCASTER, P.E.

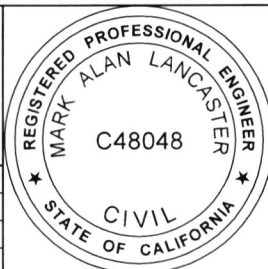

COUNTY OF RIVERSIDE

**PROPERTY LINE  
 CORNER CUT-BACK,  
 CURB RETURN RADIUS**

**STANDARD No. 805 (1 OF 2)**

REVISION	DESCRIPTION	MARK	DATE	APPROVED

NOTE:  
 DELTA = TOTAL ANGLE  
 BETWEEN BCR AND ECR

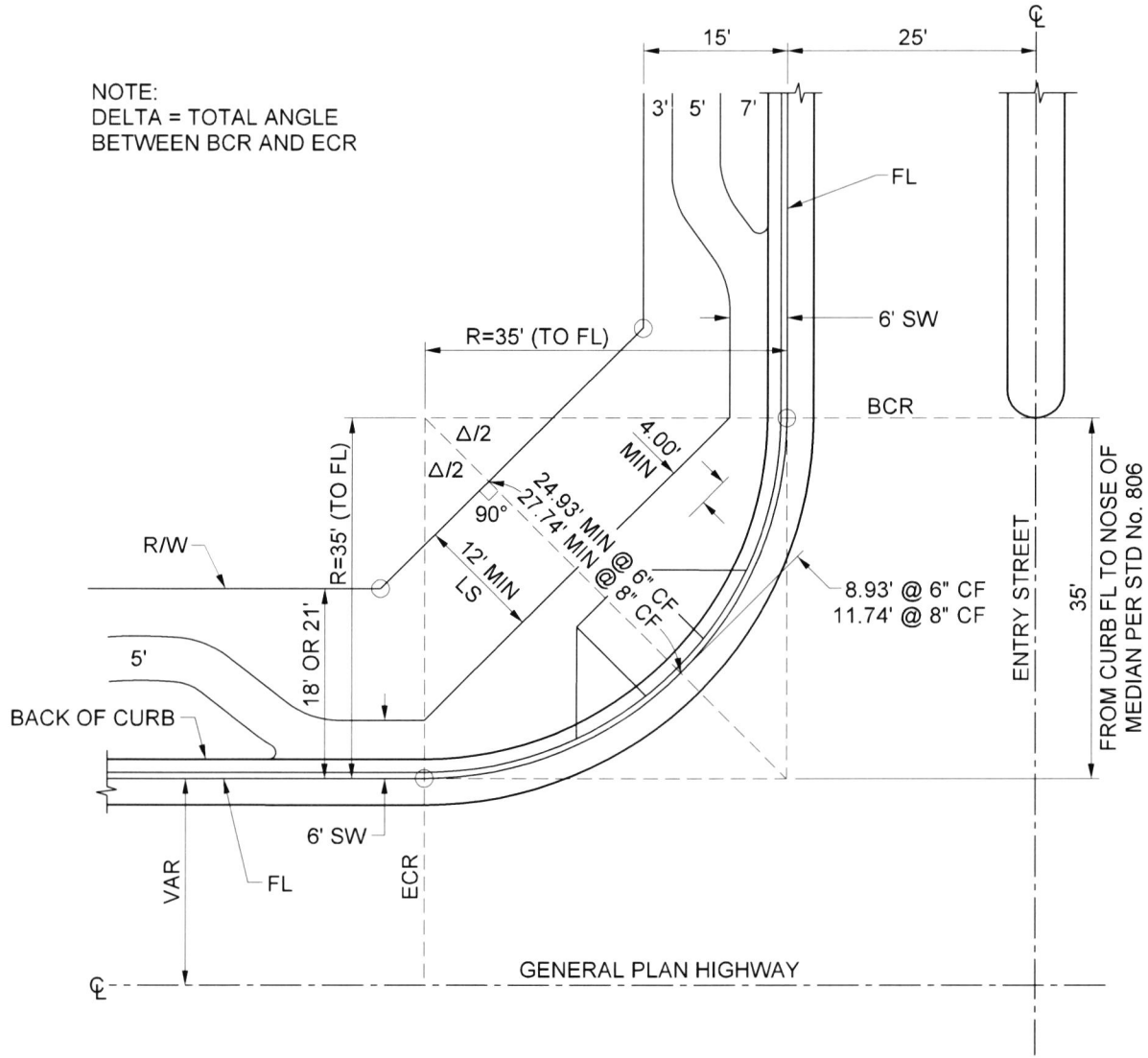

**NOTE:**

1. USE THIS EXTENDED CORNER CUT BACK FOR SCHEDULE A SUBDIVISIONS AT ALL INTERSECTIONS OF GENERAL PLAN HIGHWAYS CLASSIFIED AS SECONDARY HIGHWAY OR HIGHER WITH ALL DESIGNATED TRACT ENTRANCES. THE CORNER CUTBACK RIGHT OF WAY LINE WILL BE BE A MINIMUM OF 24.93 FEET WITH 6 INCH CURB FACE OR 27.74 FEET WITH 8 INCH CURB FACE FROM THE CURB FLOWLINE AS REQUIRED PER EXHIBIT C OF THE APPROVED COUNTYWIDE DESIGN GUIDELINES.

2. MEDIAN FOR PRIVATE ENTRY STREET SHALL BE APPROVED BY THE TRANSPORTATION DEPARTMENT.

NOT TO SCALE

PREPARED UNDER THE SUPERVISION OF:

*Mark Lancaster*  
 DIRECTOR OF TRANSPORTATION  
 MARK LANCASTER, P.E.  
 11/30/22  
 DATE

REVISION	DESCRIPTION	MARK	DATE	APPROVED

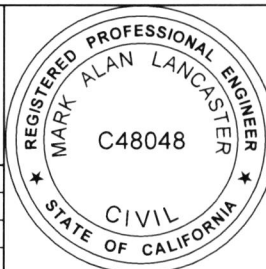

COUNTY OF RIVERSIDE

**PROPERTY LINE  
 CORNER CUT-BACK,  
 CURB RETURN RADIUS**

STANDARD No. 805 (2 OF 2)

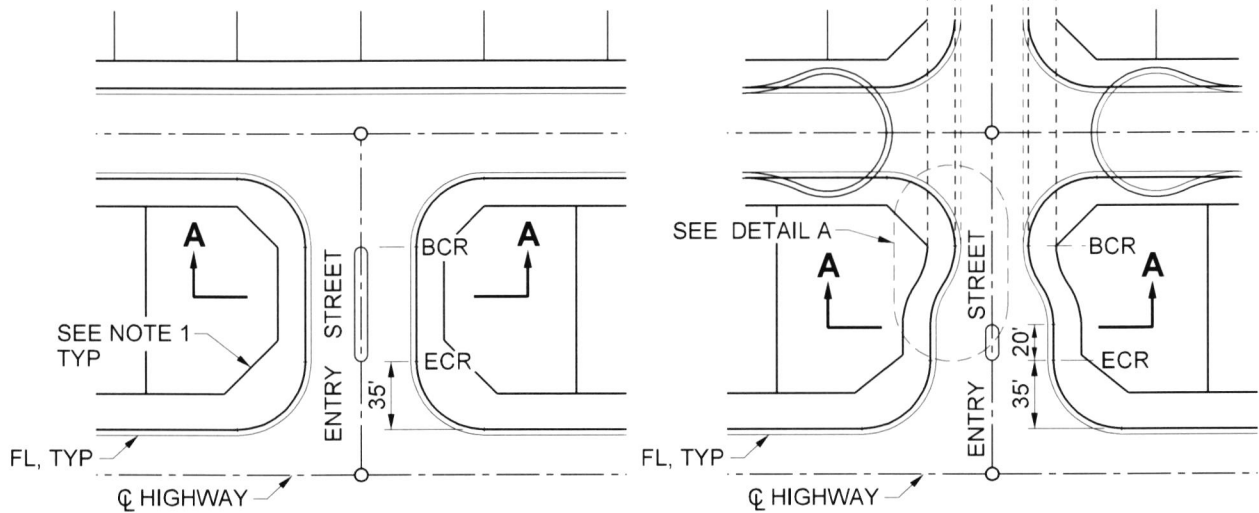

**GENERAL PLAN HIGHWAY**

**GENERAL PLAN HIGHWAY**

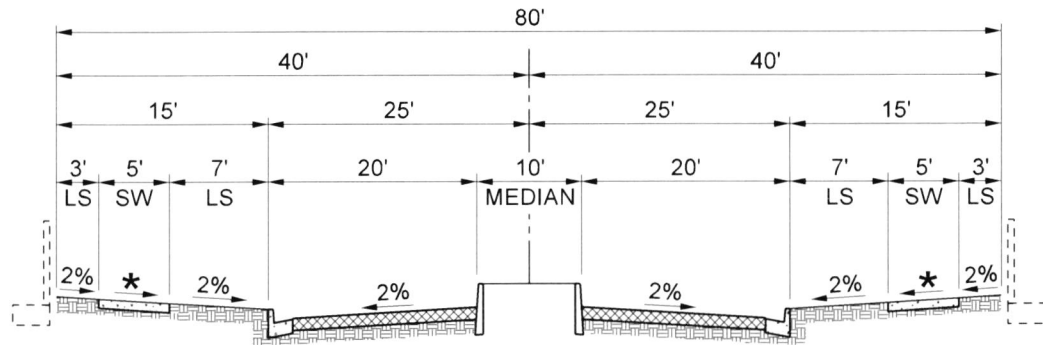

**SECTION "A-A"**

\* CROSS SLOPE OF SIDEWALK SHALL BE 1.5% (2.00% MAX AS-BUILT)

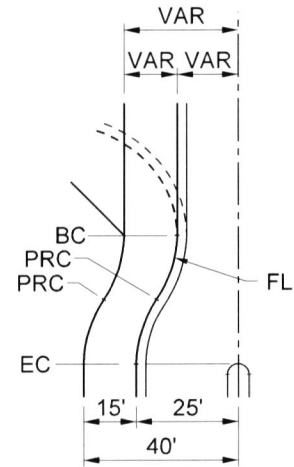

**DETAIL "A"**

**NOTE:**

1. EXTENDED CORNER CUT BACK PER STANDARD No. 805 (2 OF 2).

NOT TO SCALE

PREPARED UNDER THE SUPERVISION OF:

*Mark Lancaster*  
 DIRECTOR OF TRANSPORTATION  
 MARK LANCASTER, P.E.

11/30/22  
 DATE



COUNTY OF RIVERSIDE

**ENTRY STREET  
 50' IMP / 80' R/W**

**STANDARD No. 806**

REVISION	DESCRIPTION	MARK	DATE	APPROVED

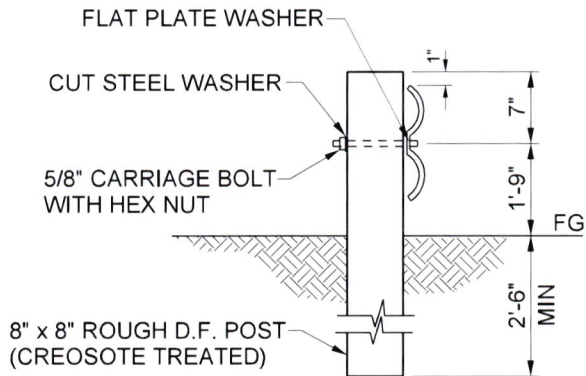

**NOTES:**

1. GUARD RAIL ELEMENT MAY BE EITHER STEEL OR ALUMINUM.
2. STEEL RAIL SHALL BE HOT-DIP GALVANIZED PER ASTM DESIGNATION A-123.
3. STEEL RAIL THICKNESS SHALL BE MIN 12 GAUGE.
4. ALUMINUM RAIL THICKNESS SHALL BE MIN 0.105 IN.
5. MEET CURRENT CALTRANS STANDARDS OR DESIGNATE BY ENGINEER.

**TYPICAL POST SPACING 12'-6" OC**

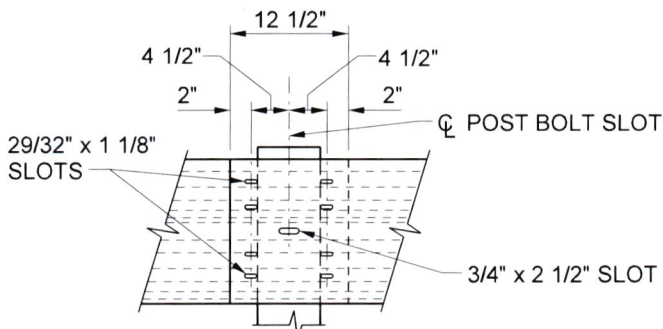

5/8" x 1 1/4" BUTTON HEAD OVAL SHOULDER BOLTS WITH 1 1/4" RECESSED HEX NUTS - TOTAL: 8 PER SPLICE AND 4 PER TERMINAL SECTION.

**RAIL SPLICE**

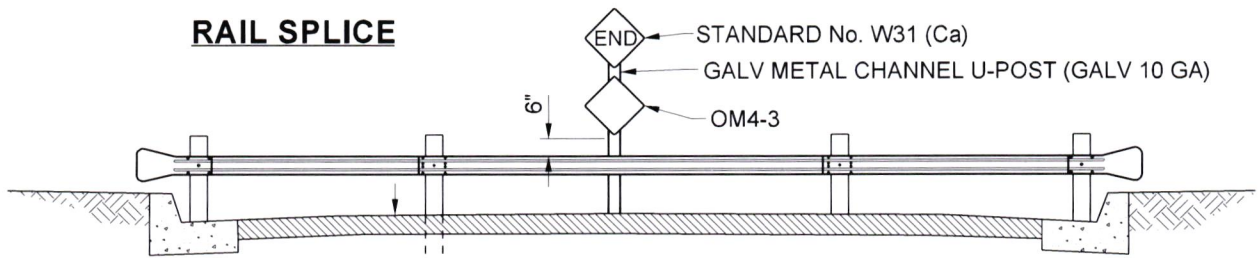

**ELEVATION**

2'-6" MINIMUM

END OF RIGHT OF WAY OR BEGINNING OF BUFFER STRIP

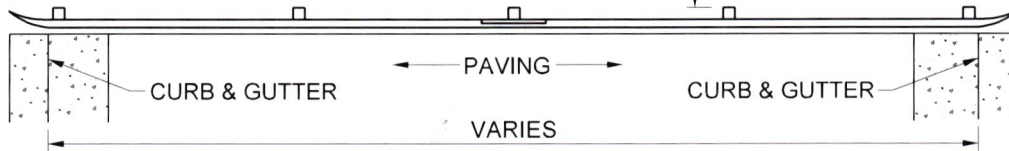

**PLAN**

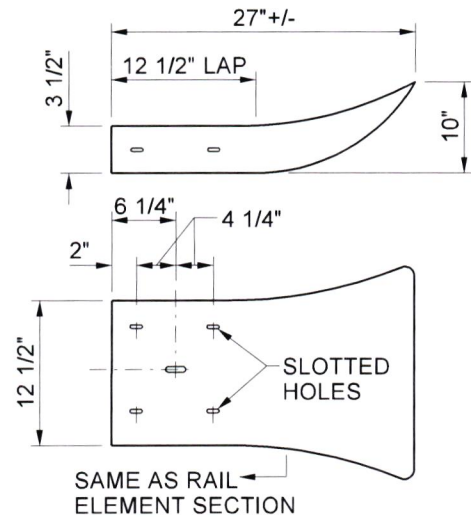

**TERMINAL SECTION**

NOT TO SCALE

PREPARED UNDER THE SUPERVISION OF:

*Mark Lancaster*  
 DIRECTOR OF TRANSPORTATION  
 MARK LANCASTER, P.E.

11/30/22  
 DATE

REVISION DESCRIPTION	MARK	DATE	APPROVED



COUNTY OF RIVERSIDE

**BARRICADE**

**STANDARD No. 810**

MULTIPLE MAILBOX TO MEET REQUIREMENTS OF U.S. POSTAL SERVICE AND BE FURNISHED BY PRIVATE OWNER (NOT COUNTY MAINTAINED)

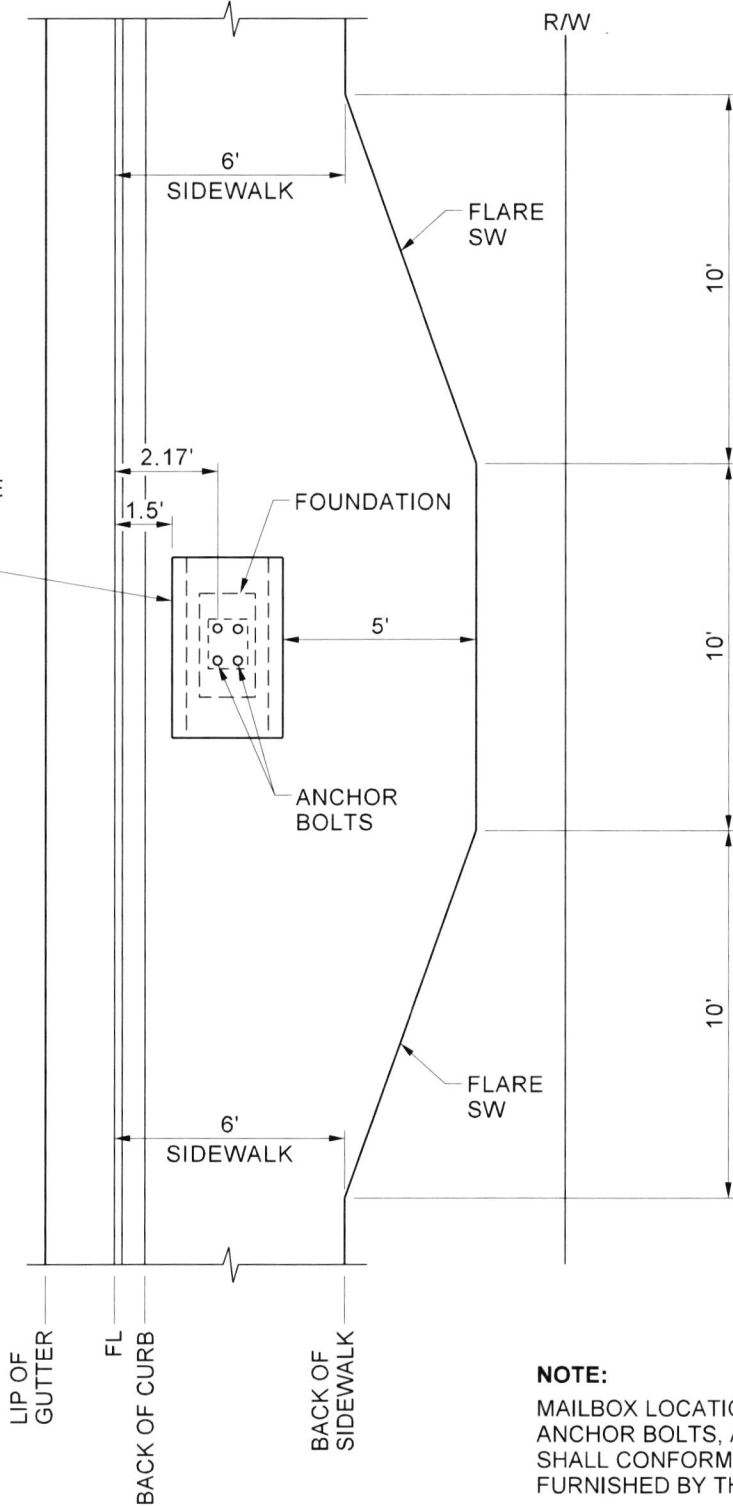

**NOTE:**  
MAILBOX LOCATION, FOUNDATION ANCHOR BOLTS, AND BOLT HOLES SHALL CONFORM TO SPECIFICATIONS FURNISHED BY THE POSTMASTER.

NOT TO SCALE

PREPARED UNDER THE SUPERVISION OF:

*Mark Lancaster*

11/30/22  
DATE

DIRECTOR OF TRANSPORTATION  
MARK LANCASTER, P.E.



COUNTY OF RIVERSIDE

**MULTIPLE MAILBOX  
INSTALLATION FOR  
NEW SIDEWALK**

**STANDARD No. 812**

REVISION DESCRIPTION	MARK	DATE	APPROVED

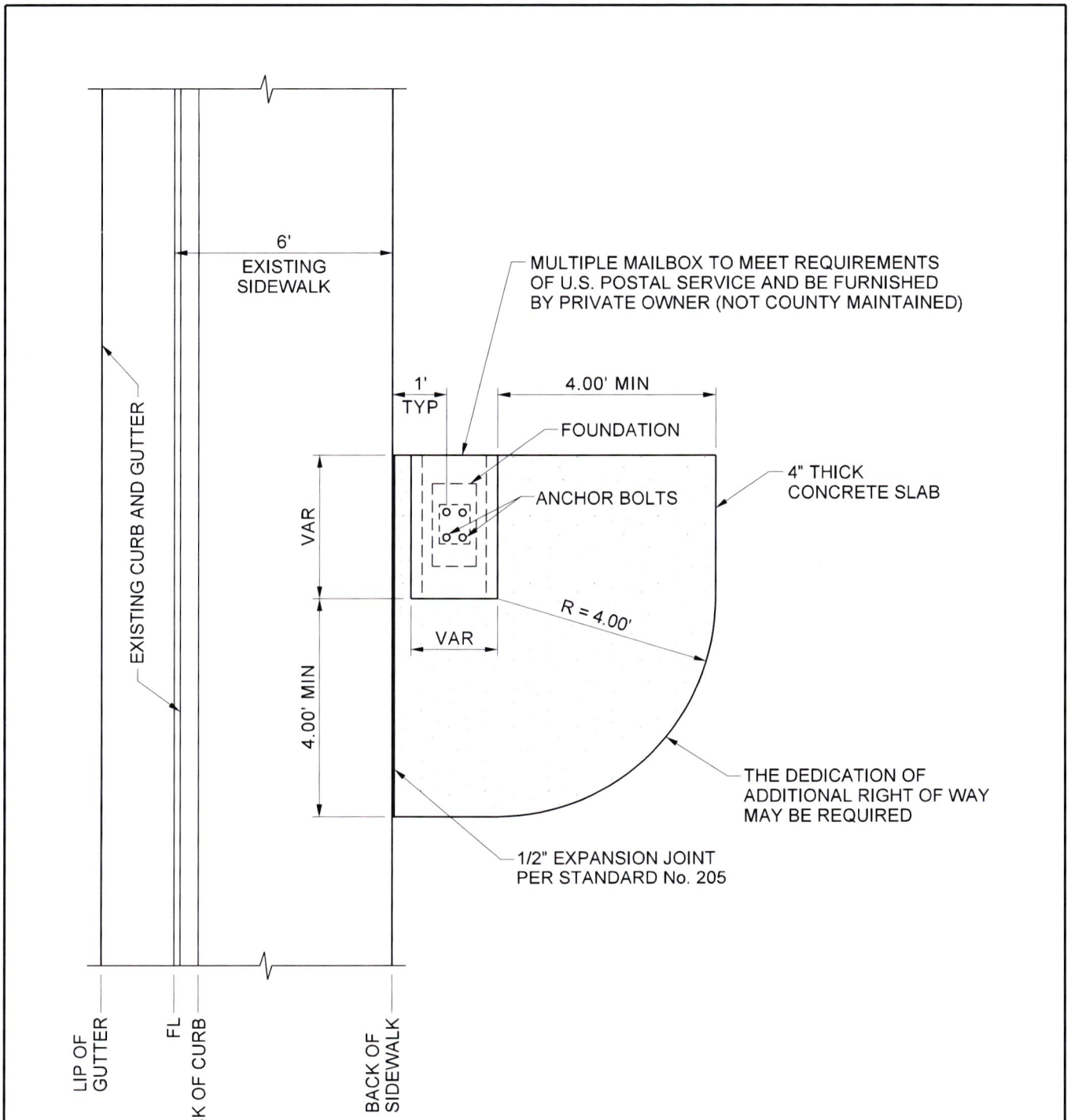

**NOTE:**  
 1. MAILBOX LOCATION, FOUNDATION ANCHOR BOLTS, AND BOLT HOLES SHALL CONFORM TO SPECIFICATIONS FURNISHED BY THE POSTMASTER. MAILBOX FOUNDATION AND SLAB TO BE A MONOLITHIC POUR.

NOT TO SCALE

PREPARED UNDER THE SUPERVISION OF:

*Mark Lancaster*  
 DIRECTOR OF TRANSPORTATION  
 MARK LANCASTER, P.E.  
 11/30/22  
 DATE

REVISION	DESCRIPTION	MARK	DATE	APPROVED



COUNTY OF RIVERSIDE

**MULTIPLE MAILBOX  
 INSTALLATION FOR  
 EXISTING SIDEWALK**

**STANDARD No. 813**

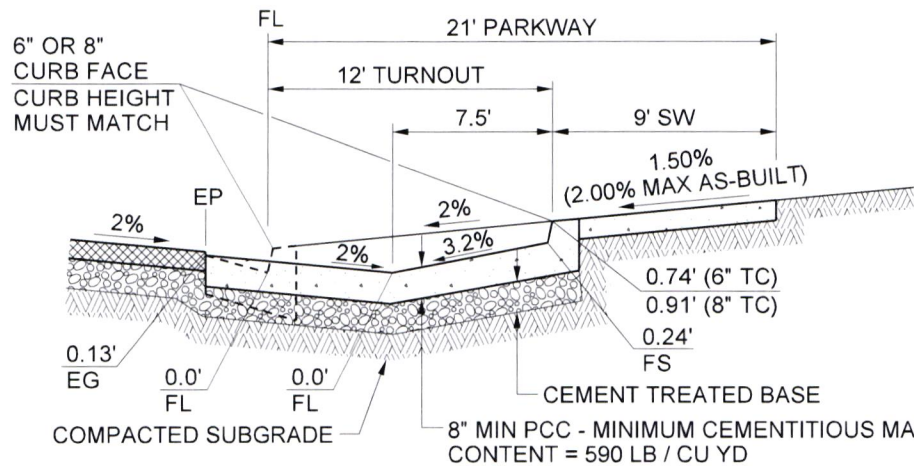
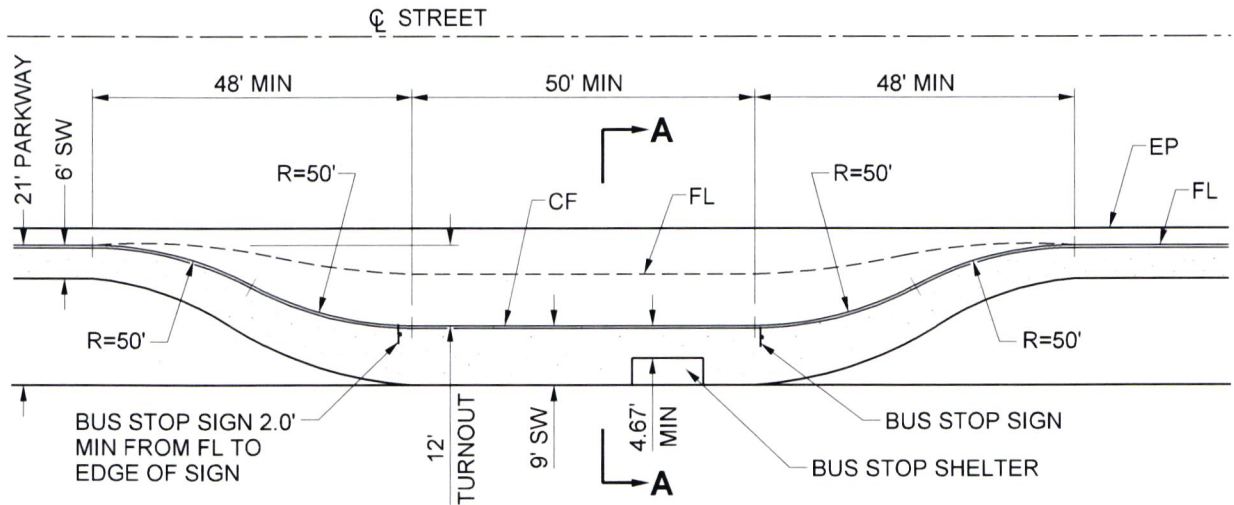

**CURB DATA**

R = 50'

$\Delta = 28^\circ 21' 27''$

L = 24.75'

T = 12.63'

**SECTION "A-A"**

**NOTES:**

1. THICKNESS OF PCC AND BASE DEPENDS UPON ADT VOLUME AND SOIL TYPE. STRUCTURAL SECTION CALCULATIONS ARE REQUIRED.
2. LOCATION OF BUS TURNOUT SHOULD BE AS APPROVED BY THE TRANSPORTATION DEPARTMENT, AND IN CONSULTATION WITH THE APPROPRIATE TRANSIT AGENCY.
3. FAR SIDE BUS TURNOUT IS THE PREFERRED LOCATION:

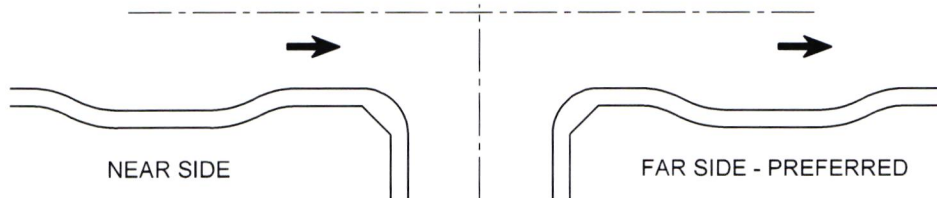

4. WHEN ABUTTING SOIL HAS A HIGH SULFATE CONTENT, USE A MODIFIED CONCRETE MIX AND PLACE 6" MIN CLASS 2 AGGREGATE BASE AND 6 MIL PLASTIC SHEETING UNDER AND AROUND ALL SIDES OF CONCRETE IMPROVEMENTS. FOR EXPANSIVE SOIL, PLACE 6" MIN CLASS 2 AGGREGATE BASE UNDER CONCRETE IMPROVEMENTS AS DIRECTED BY THE ENGINEER. SEE SPECIFICATIONS SECTIONS 16.03 & 16.04 AND STANDARD No. 401 FOR REFERENCE.

NOT TO SCALE

PREPARED UNDER THE SUPERVISION OF:

*Mark Lancaster*  
 DIRECTOR OF TRANSPORTATION  
 MARK LANCASTER, P.E.

11/30/22  
 DATE

REVISION	DESCRIPTION	MARK	DATE	APPROVED



COUNTY OF RIVERSIDE

**BUS TURNOUT**

**STANDARD No. 814**



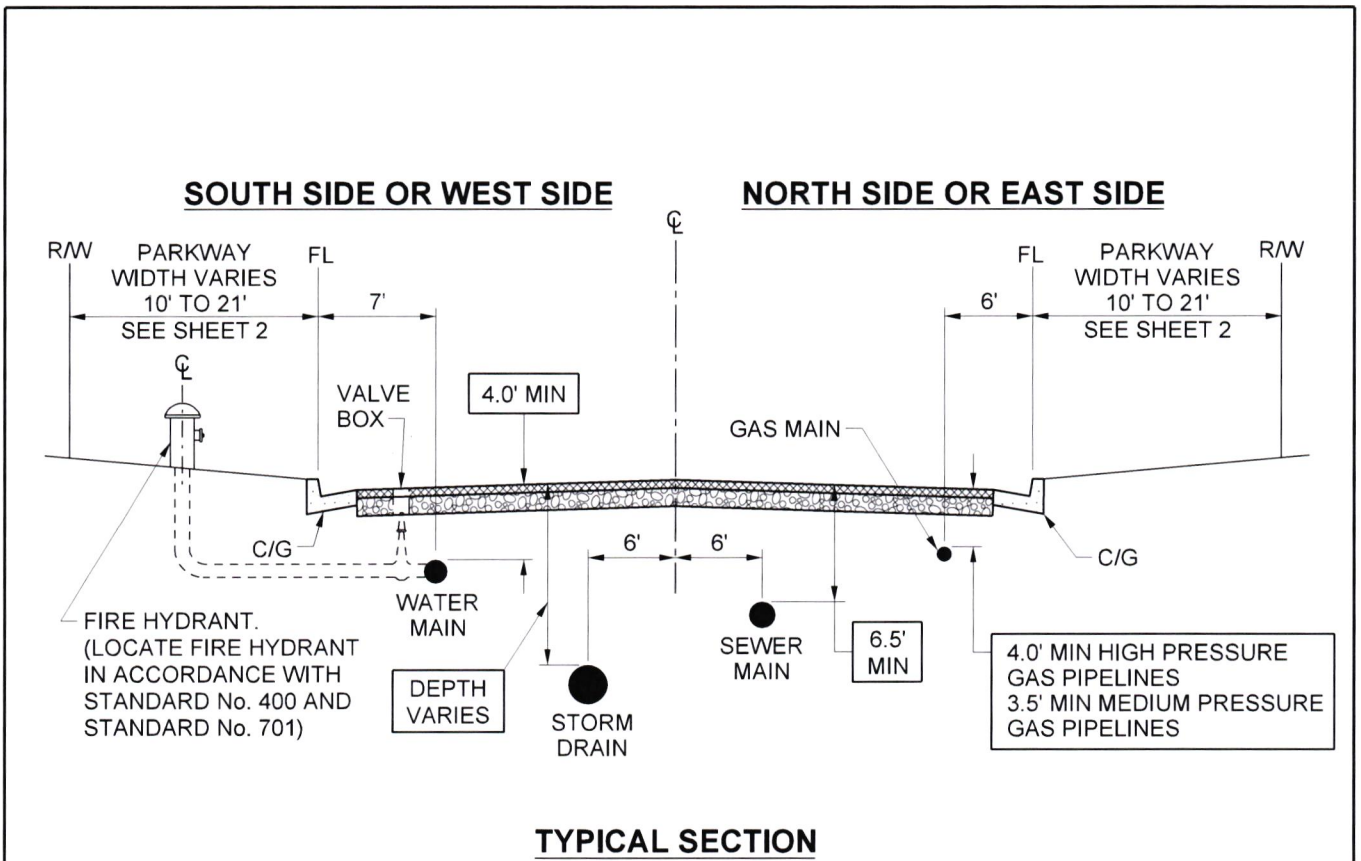

**NOTES:**

1. LOCATION AND DEPTH OF EXISTING AND PROPOSED UTILITIES MUST BE PROVIDED BY THE SUBDIVIDER, AND SHOWN ON ANY PLANS SUBMITTED TO THE TRANSPORTATION DEPARTMENT FOR APPROVAL.
2. CHANGES MAY BE PERMITTED BY THE DIRECTOR OF TRANSPORTATION IN CASES OF CONFLICTING FACILITIES.
3. CONFLICTS BETWEEN UTILITY COMPANY FACILITIES, EXISTING AND PROPOSED, MUST BE MUTUALLY RESOLVED BY THE UTILITY COMPANIES.
4. ABOVE-GROUND FACILITIES SHALL BE LOCATED BEHIND SIDEWALK WHEN SIDEWALK IS ADJACENT TO CURB.
5. FOR TREE INSTALLATION ON LOCAL STREETS, TREES SHALL BE LOCATED 2 FEET CLEAR OUTSIDE OF R/W WHEN SIDEWALK IS ADJACENT TO CURB.
6. ALL UTILITIES UNDER PAVEMENT OR CURB & GUTTER SHALL BE A MINIMUM OF 3.5' BELOW THE FINISHED GRADE OF THE STREET.

NOT TO SCALE

PREPARED UNDER THE SUPERVISION OF:

*Mark Lancaster*  
 DIRECTOR OF TRANSPORTATION  
 MARK LANCASTER, P.E.  
 11/30/22  
 DATE

REVISION	DESCRIPTION	MARK	DATE	APPROVED



COUNTY OF RIVERSIDE

**UNDERGROUND  
 UTILITY LOCATIONS**

**STANDARD No. 817 (1 OF 2)**

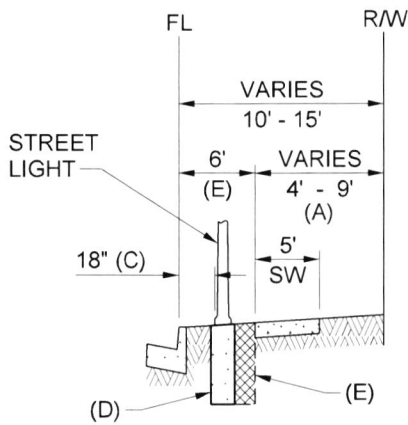

**10' - 15' PARKWAY**

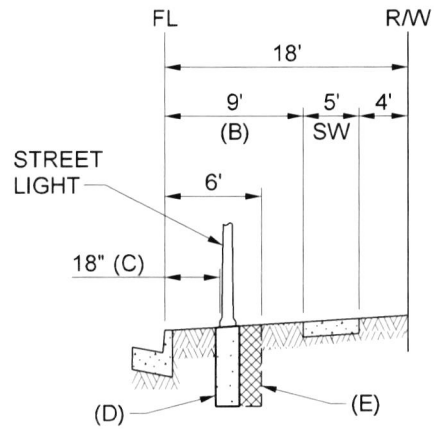

**18' PARKWAY**

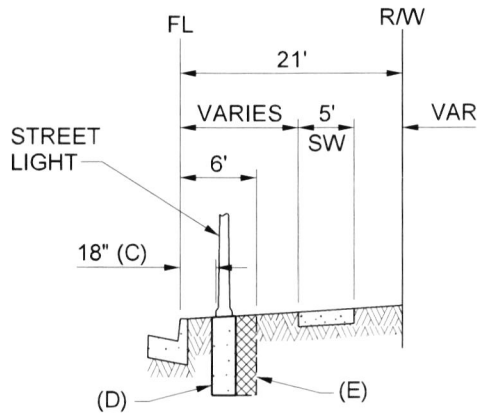

**SECTION**

**21' PARKWAY**

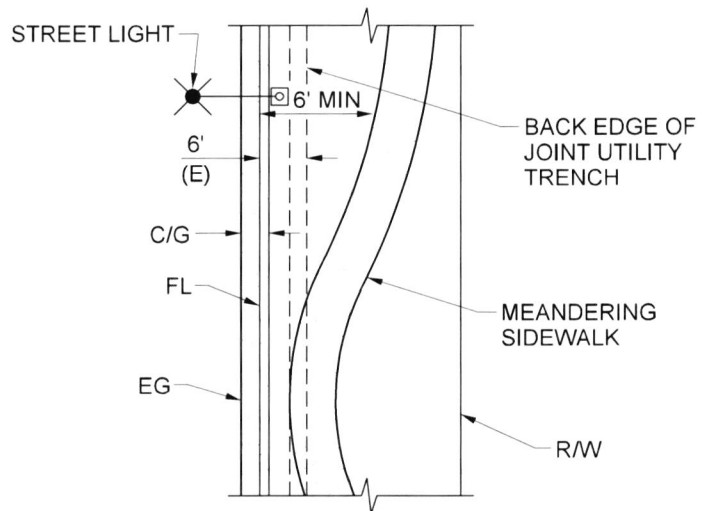

**PLAN**

**NOTES:**

- (A) SIDEWALK LOCATION VARIES.
- (B) 9 FEET FROM FLOWLINE TO FRONT OF SIDEWALK.
- (C) 1.5 FEET FROM FLOWLINE TO BASE OF STREET LIGHT. SEE STANDARDS No. 1000 & 1001.
- (D) STREET LIGHT FOUNDATION: SEE STANDARD No. 1000 OR 1001 FOR RESIDENTIAL AND ARTERIAL LIGHTING DETAILS.
- (E) 6' FROM FLOW LINE TO BACK OF JOINT UTILITY TRENCH. ADJUST TRENCH TO AVOID CONFLICTS.
- (F) ALL UNDERGROUND UTILITIES BETWEEN CURB AND R/W SHALL BE MINIMUM OF 2.5' BELOW TOP OF CURB GRADE.

NOT TO SCALE

PREPARED UNDER THE SUPERVISION OF:

*Mark Lancaster*  
 DIRECTOR OF TRANSPORTATION  
 MARK LANCASTER, P.E.  
 11/30/22  
 DATE

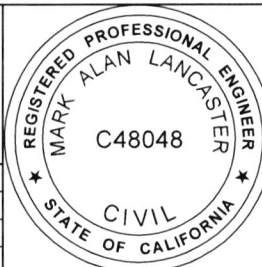

COUNTY OF RIVERSIDE

**UNDERGROUND  
 UTILITY LOCATIONS**

**STANDARD No. 817 (2 OF 2)**

REVISION	DESCRIPTION	MARK	DATE	APPROVED

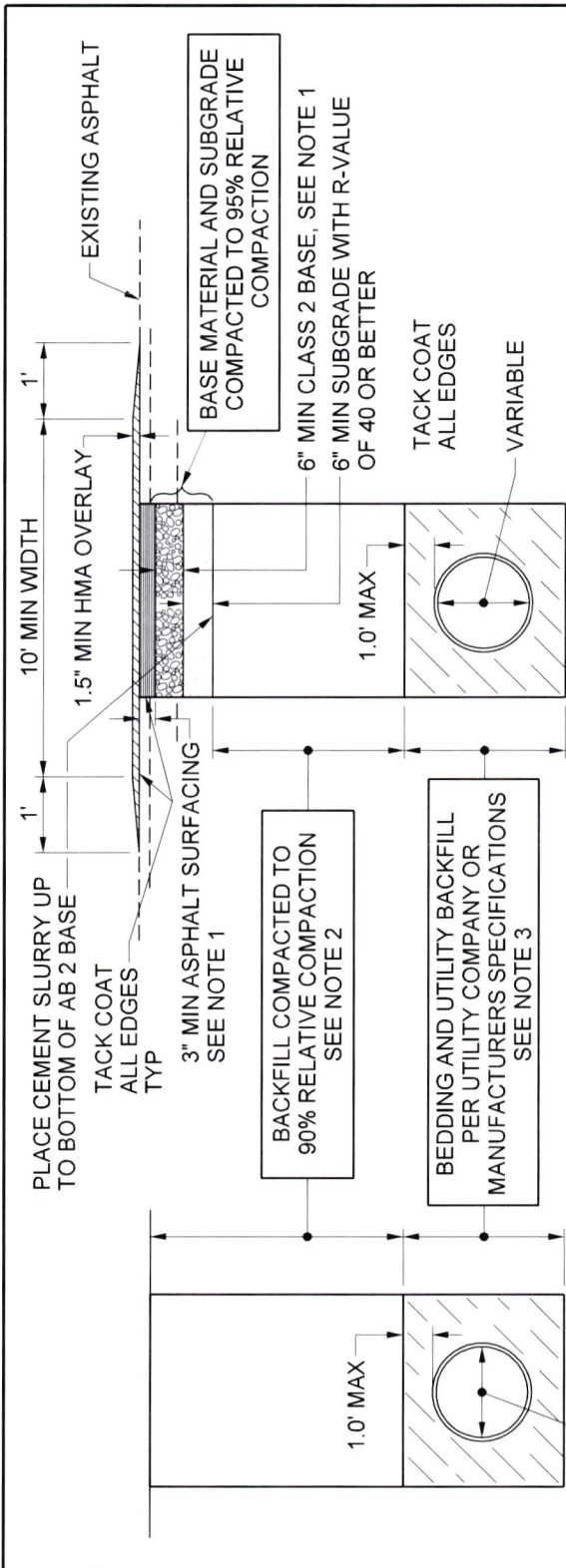

**NON-ASPHALT SURFACED AREAS**  
**CASE 1**

**ASPHALT SURFACED STREETS WITH OVERLAY PARALLEL INSTALLATION**  
**CASE 2**

**NOTES:**

1. REPLACE STRUCTURAL SECTION AS FOLLOWS:  
SURFACING: EXISTING THICKNESS; OR 3" MIN HMA.  
BASE: CLASS 2 AB IN SAME THICKNESS AS EXISTING BASE.  
MATERIAL: 6" MIN AS DIRECTED BY THE INSPECTOR.  
IF A GEOSYNTHETIC MATERIAL (GEOGRID) IS ENCOUNTERED, TRENCH THROUGH GEOGRID AND PERFORM ONE OF THE FOLLOWING:  
1) REPLACE GEOGRID AT SAME ELEVATION WITH BUTT JOINT;  
2) DOUBLE THE THICKNESS OF EXISTING BASE; OR  
3) REPLACE EXISTING BASE WITH CEMENT SLURRY.
2. NO PONDING OR JETTING ALLOWED. A 1/2 SACK CEMENT SLURRY FOR DEEP (>4') AND 1 SACK CEMENT SLURRY FOR SHALLOW (<4') TRENCHES.
3. WHEN SOFT, SPONGY OR UNSUITABLE MATERIAL IS ENCOUNTERED, SUCH MATERIAL SHALL BE REMOVED TO THE LIMITS DIRECTED BY THE DIRECTOR OF TRANSPORTATION OR AFFECTED UTILITY COMPANY AND THE RESULTING EXCAVATION BACKFILLED WITH PIPE BEDDING MATERIAL.
4. WHEN REQUIRED IN THE ENCROACHMENT PERMIT OR AS DIRECTED BY THE INSPECTOR, THE NEW HMA SHOWN IN CASE 2 AND CASE 3 SHALL BE PLACED FLUSH WITH THE EXISTING ASPHALT. ADDITIONAL 1-FOOT GRINDING OF THE EXISTING ASPHALT BEYOND THE EXCAVATION LIMIT OF THE TRENCH SHALL BE REQUIRED AND AS DETERMINED BY THE COUNTY.

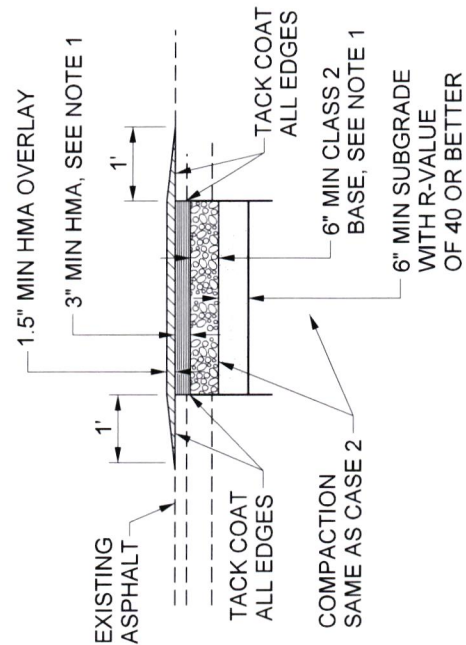

**ASPHALT SURFACED STREET WITHOUT OVERLAY PERPENDICULAR INSTALLATION**  
**CASE 3**

NOT TO SCALE

PREPARED UNDER THE SUPERVISION OF:

*Mark Lancaster*

11/30/22  
DATE

DIRECTOR OF TRANSPORTATION  
MARK LANCASTER, P.E.



COUNTY OF RIVERSIDE

**UTILITY TRENCH BACKFILL**

STANDARD No. 818

REVISION	DESCRIPTION	MARK	DATE	APPROVED

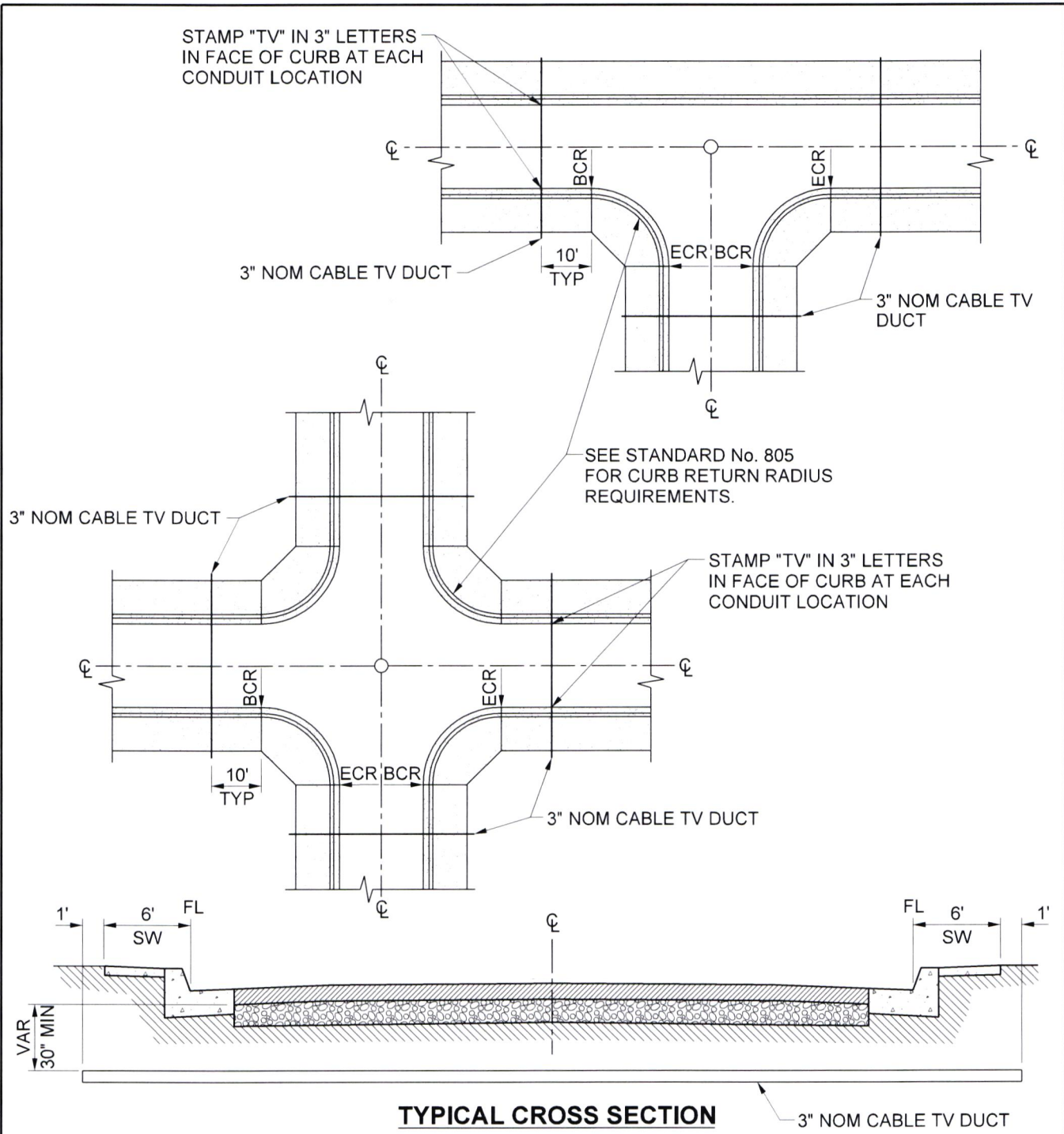

**NOTE:**  
 1. 3" NOM CABLE TV DUCTS SHALL BE SCHEDULE 80 PVC, RIGID GALVANIZED STEEL CONDUITS, OR APPROVED EQUAL.

NOT TO SCALE

PREPARED UNDER THE SUPERVISION OF:

*Mark Lancaster*  
 DIRECTOR OF TRANSPORTATION  
 MARK LANCASTER, P.E.      11/30/22  
 DATE

REVISION	DESCRIPTION	MARK	DATE	APPROVED



COUNTY OF RIVERSIDE  
**LOCATION OF CABLE TV  
 DUCTS AT  
 STREET INTERSECTIONS**  
 STANDARD No. 819

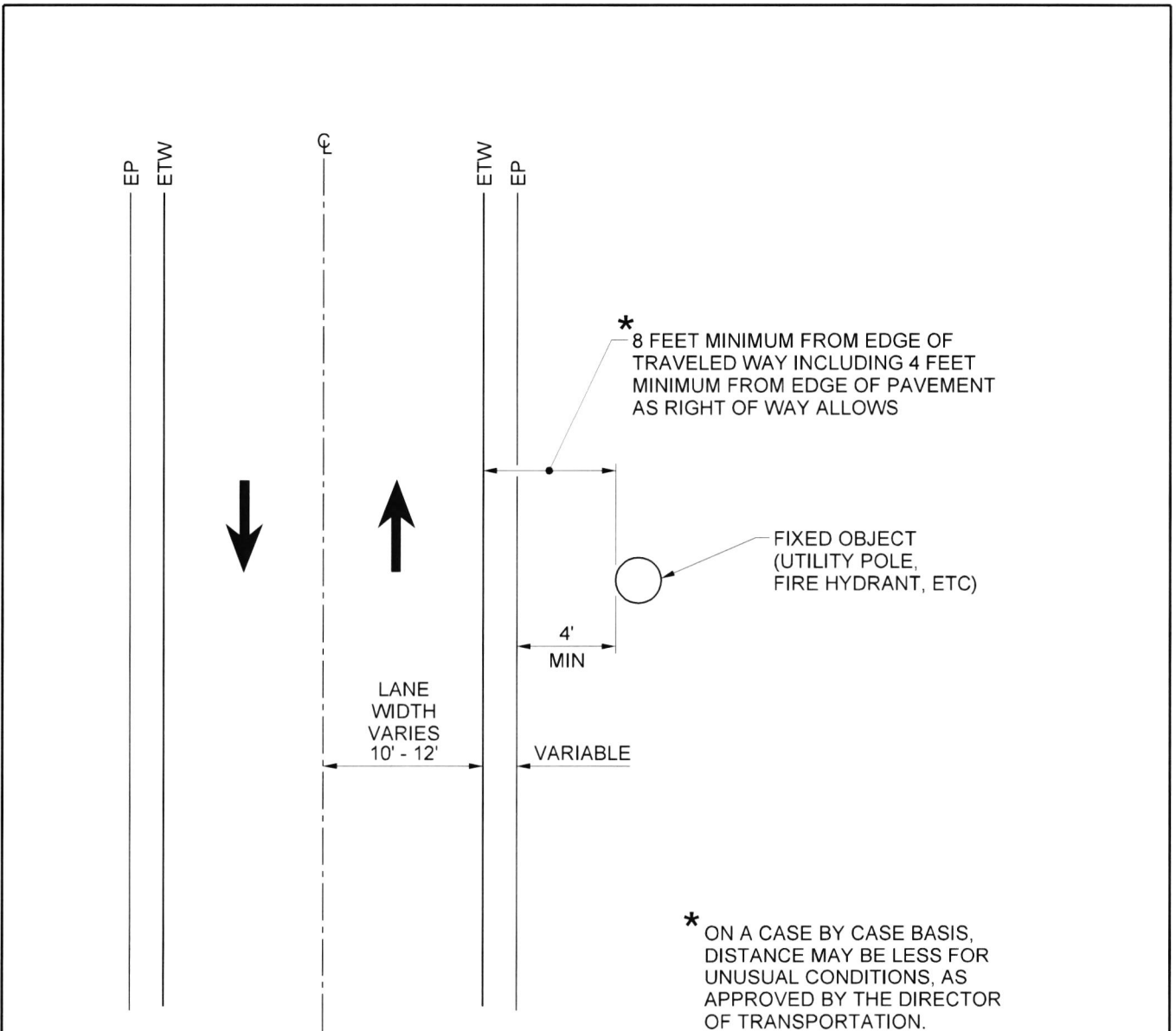

**NOTES:**

1. TO AVOID FUTURE RELOCATIONS, ALL INSTALLATIONS SHOULD BE MADE IN THE ULTIMATE LOCATIONS BEHIND FUTURE CURB, IN ACCORDANCE WITH STANDARDS No. 400 AND 817 IF POSSIBLE.
2. FOR APPLICATIONS ADJACENT TO CURB AND GUTTER USE STANDARDS No. 400 AND 817.

NOT TO SCALE

PREPARED UNDER THE SUPERVISION OF:

*Mark Lancaster*  
 DIRECTOR OF TRANSPORTATION  
 MARK LANCASTER, P.E.

11/30/22  
 DATE



COUNTY OF RIVERSIDE

**FIXED OBJECT PLACEMENT  
 FOR ROADWAYS  
 WITHOUT CURBS**

**STANDARD No. 820**

REVISION DESCRIPTION	MARK	DATE	APPROVED

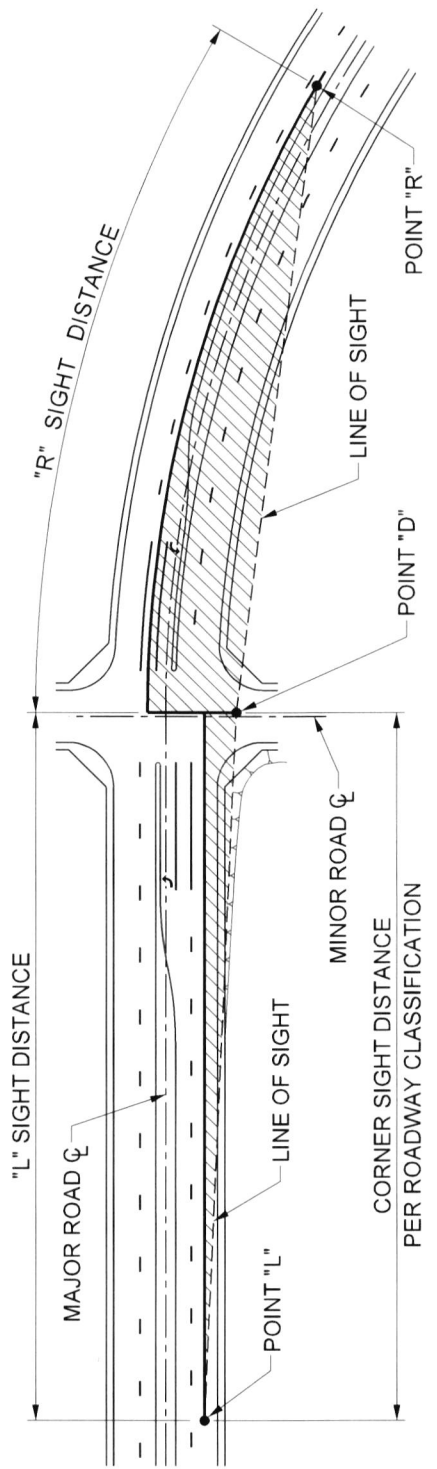

**LEGEND:**  
 LIMITED USE AREA  
 - - - SIGHT LINE  
 - - - CENTERLINE OF ROADWAY

**NOTES:**

- POINT "D"** IS THE DECISION POINT, MEASURED 3' TO THE RIGHT OF MINOR ROAD CENTERLINE, 15' BACK FROM THE EDGE OF THE TRAVELED WAY OR 8' BACK FROM THE STOP BAR WHICHEVER IS GREATER.
- POINTS "L" & "R"** ARE LOCATED AT THE END OF THE REQUIRED SIGHT DISTANCES MEASURED FROM POINT "D", WHERE DRIVER WITH EYE LEVEL AT 3.5' ABOVE ROAD SURFACE CAN SEE A 3.5' HEIGHT OBJECT AT POINT "L" AND "R".
- LINE OF SIGHT** IS THE STRAIGHT LINE CONNECTING POINT "D" TO POINT "L", AND POINT "D" TO POINT "R".
- SIGHT DISTANCE** SHALL BE MEASURED ALONG THE CENTERLINE OF THE NEAREST APPROACHING TRAFFIC LANE.
- LIMITED USE AREA.** THE AREA BOUNDED BY SIGHT LINES AND CENTERLINES OF THE NEAREST APPROACHING TRAFFIC LANES, SHALL BE SHOWN AT INTERSECTIONS ON TENTATIVE MAPS, SITE PLANS, GRADING PLANS, STREET PLANS, AND LANDSCAPE PLANS. THIS AREA SHALL BE CLEAR OF ALL OBSTRUCTIONS MORE THAN 18 INCHES ABOVE ROAD SURFACE INCLUDING VEGETATION. SELECTED PLANT MATERIAL SHALL HAVE MATURE HEIGHT LESS THAN 12" WITHOUT TRIMMING. HARDSCAPE IS PREFERRED WITHIN THE LIMITED USE AREA.
- WHEN AN INTERSECTION IS LOCATED ON A VERTICAL CURVE, A PROFILE OF THE SIGHT LINE SHALL BE PROVIDED.

DESIGN SPEED (MPH)	SIGHT DISTANCE (FT)	
	PUBLIC STREETS <sup>1</sup>	PRIVATE STREETS <sup>2</sup>
20	220	125
25	275	150
30	330	200
35	385	250
40	440	300
45	495	360
50	550	430
55	605	500
60	660	580
65	715	660

1. BASED ON 7.5 S GAP TIME FOR CROSSING 2-LANE HIGHWAY; ADD 0.5 S FOR EACH ADDITIONAL LANE TO BE CROSSED; AND ADD 0.2 S FOR EACH PERCENT GRADE WHEN MINOR ROAD'S APPROACH EXCEEDS 3% UPGRADE. SIGHT DISTANCE = 1.47 x DESIGN SPEED (MPH) x GAP TIME (S).

2. PER CALTRANS HIGHWAY DESIGN MANUAL INDEX 405.1(2)(C), THE MIN. CORNER SIGHT DISTANCE SHALL BE EQUAL TO STOPPING SIGHT DISTANCE AS SHOWN ON TABLE 201.1.

NOT TO SCALE

PREPARED UNDER THE SUPERVISION OF:

*Mark Lancaster*  
 DIRECTOR OF TRANSPORTATION  
 MARK LANCASTER, P.E.  
 11/30/22  
 DATE

REVISION	DESCRIPTION	MARK	DATE	APPROVED



COUNTY OF RIVERSIDE

**INTERSECTION SIGHT DISTANCE**

STANDARD No. 821

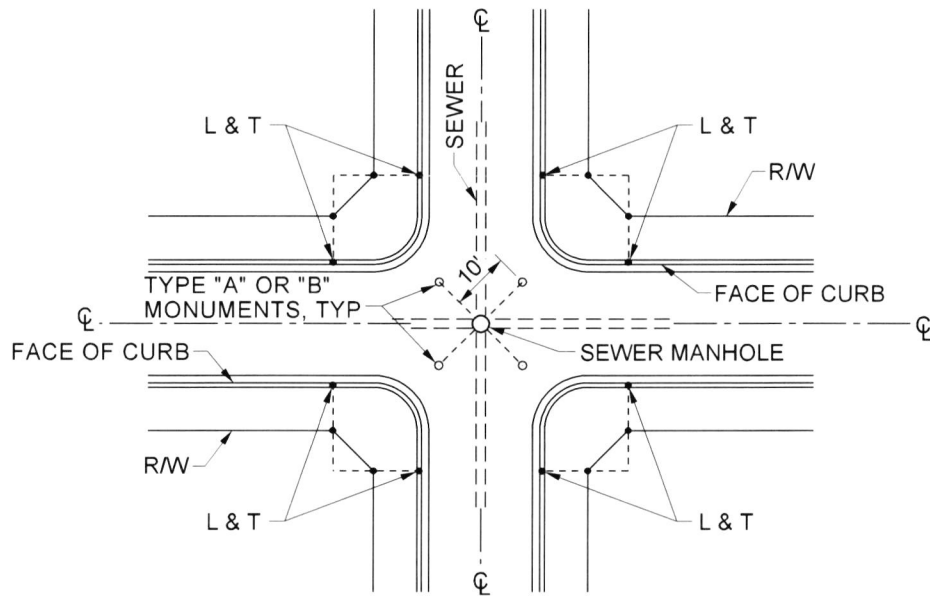

**MONUMENTING STREET CENTERLINES WHEN SEWERS ARE LOCATED ON CENTERLINE USING 10' CROSS TIES AND/OR SWING TIES**

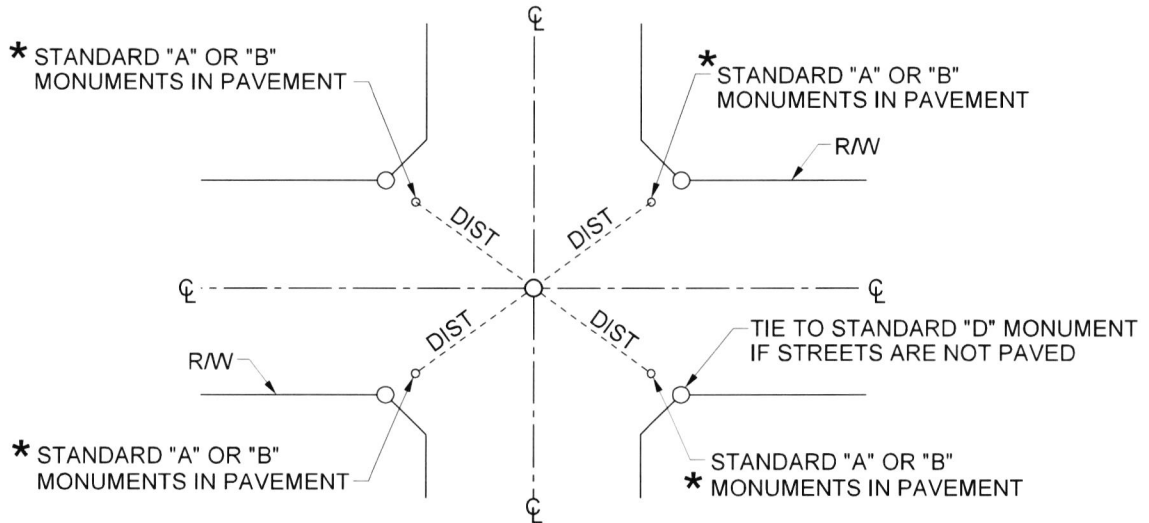

**MONUMENTING STREET CENTERLINES WHERE CURBS ARE NOT REQUIRED**

\* SET TIE IN PAVEMENT IF R/W IS UNAVAILABLE.

**NOTES:**

1. L & T AS SHOWN HEREON INDICATES LEAD AND TACK OR STEEL PIN MONUMENT SET IN CURB.
2. LEAD AND TACK OR STEEL PIN MONUMENT WITNESS TO PROPERTY CORNER MAY BE SET, NOT REQUIRED.
3. SEE MONUMENT SPECIFICATIONS SECTION 21 OF THIS ORDINANCE FOR TYPE "A", "D", & "E" MONUMENT DESCRIPTION AND STANDARD No. 903 FOR TYPE "B" MONUMENT DRAWING. SEE SPECIFICATIONS SECTION 21.07 OF THIS ORDINANCE FOR MONUMENT SCHEDULE.

NOT TO SCALE

PREPARED UNDER THE SUPERVISION OF:

*Mark Lancaster*  
 DIRECTOR OF TRANSPORTATION  
 MARK LANCASTER, P.E.  
 11/30/22  
 DATE



COUNTY OF RIVERSIDE

**TIE-OUT STANDARDS**

**STANDARD No. 900**

REVISION	DESCRIPTION	MARK	DATE	APPROVED

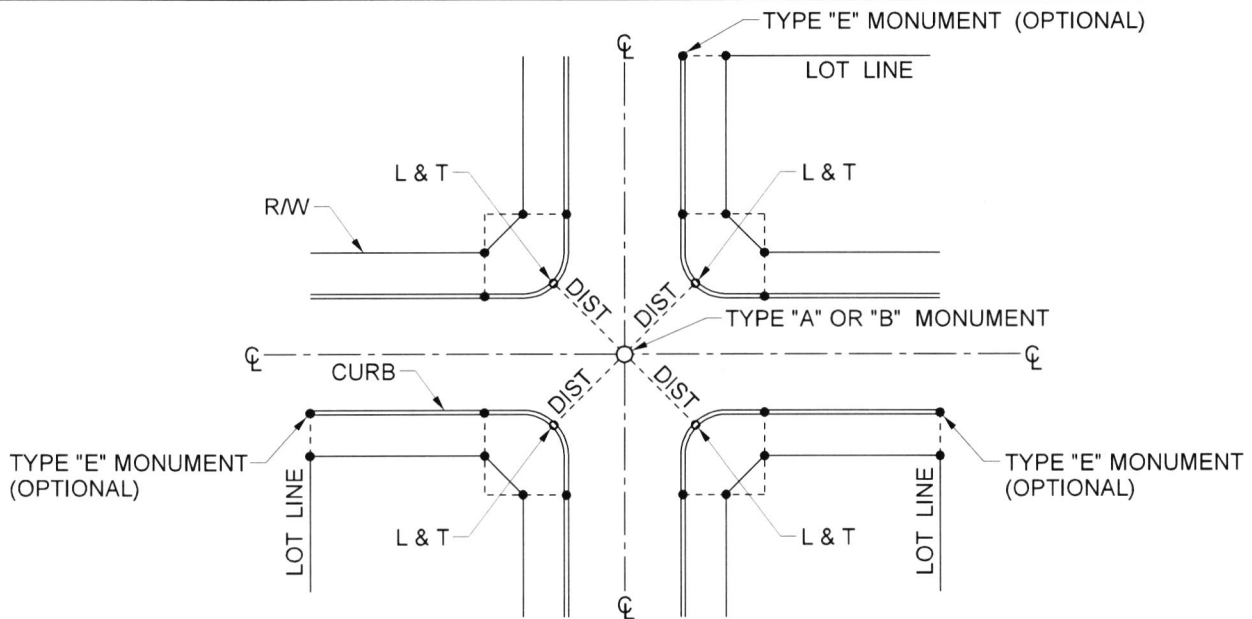

**MONUMENTING STREET INTERSECTIONS  
WHERE CURBS AND GUTTERS ARE INSTALLED**

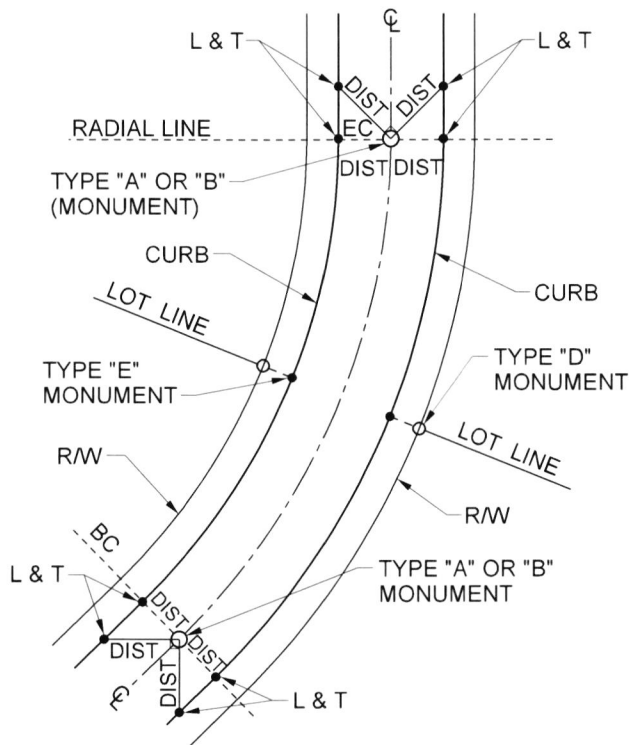

**MONUMENTING  
BEGINNING AND ENDING OF CURVE**

**NOTES:**

1. L & T SHOWN HEREON INDICATES A LEAD AND TACK OR STEEL PIN MONUMENT SET IN CONCRETE CURB.
2. A METAL IDENTIFICATION DISK SET WITH A LEAD AND TAG OR STEEL PIN MONUMENT WITNESS TO PROPERTY CORNER MAY BE SET ("E" MONUMENT), IN LIEU OF SETTING FRONT LOT CORNERS ("D" MONUMENT).
3. THE PI OF THE CURVE CENTERLINE OF A STREET MAY BE MONUMENTED IN LIEU OF EC & BC, IF THE PI FALLS WITHIN THE TRAVELED WAY. IT SHALL BE REFERENCED WITH L & T'S IN CURB.
4. SEE MONUMENT SPECIFICATIONS SECTION 21 OF THIS ORDINANCE FOR TYPE "A", "D", & "E" MONUMENT DESCRIPTION AND STANDARD No. 903 FOR TYPE "B" MONUMENT DRAWING. SEE SPECIFICATIONS SECTION 21.07 OF THIS ORDINANCE FOR MONUMENT SCHEDULE.
5. TYING OUT BC'S AND EC'S WITH 90 DEGREE TIES INTO THE TANGENT.

NOT TO SCALE

PREPARED UNDER THE SUPERVISION OF:

*Mark Lancaster*  
DIRECTOR OF TRANSPORTATION  
MARK LANCASTER, P.E.

11/30/22  
DATE

REVISION DESCRIPTION	MARK	DATE	APPROVED

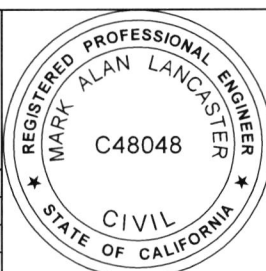

COUNTY OF RIVERSIDE

**STREET CENTERLINE  
MONUMENT**

**STANDARD No. 901**



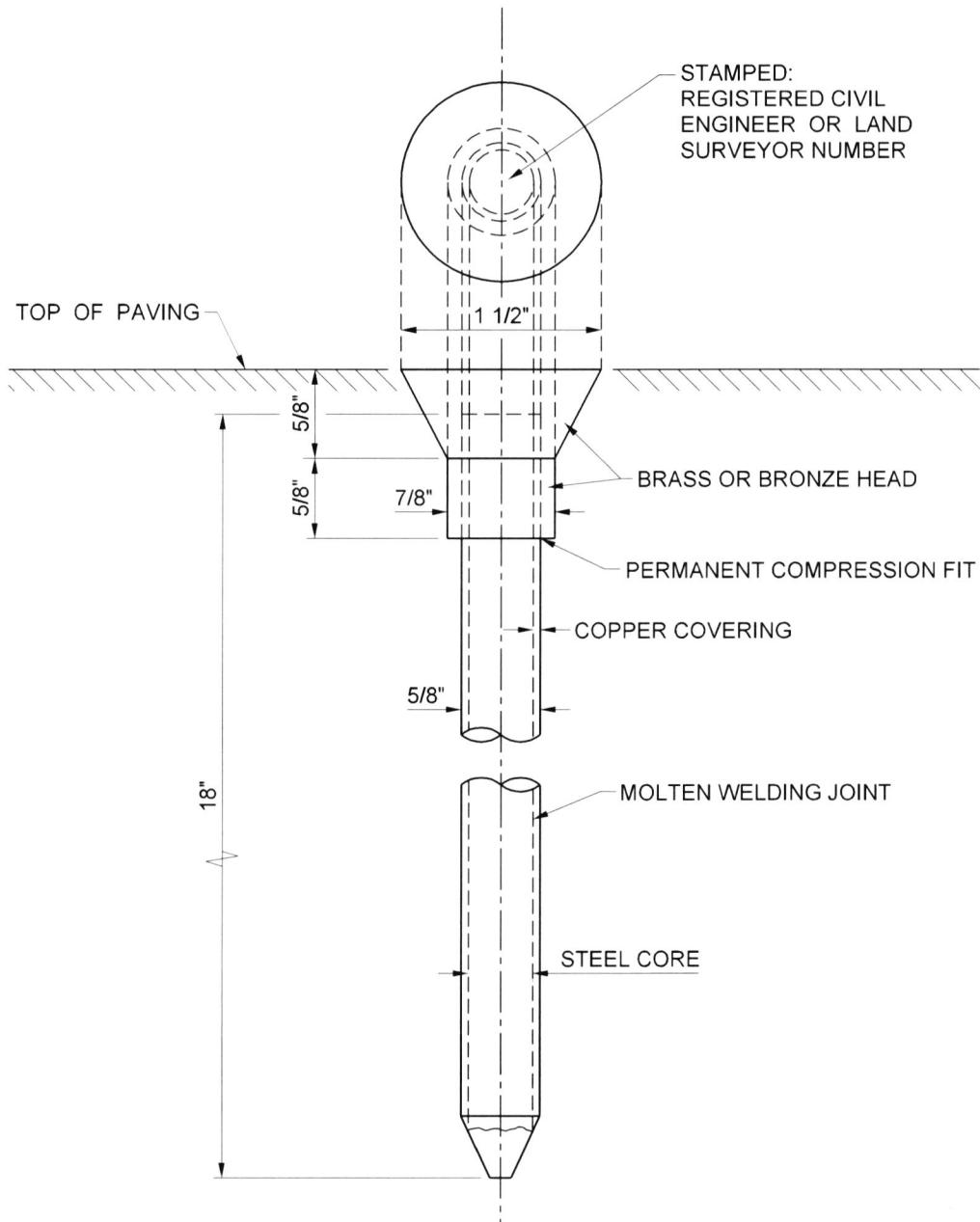

NOT TO SCALE

PREPARED UNDER THE SUPERVISION OF:

*Mark Lancaster*

DIRECTOR OF TRANSPORTATION  
MARK LANCASTER, P.E.

11/30/22  
DATE

REVISION	DESCRIPTION	MARK	DATE	APPROVED



COUNTY OF RIVERSIDE

**TYPE "B" MONUMENT**

**STANDARD No. 903**

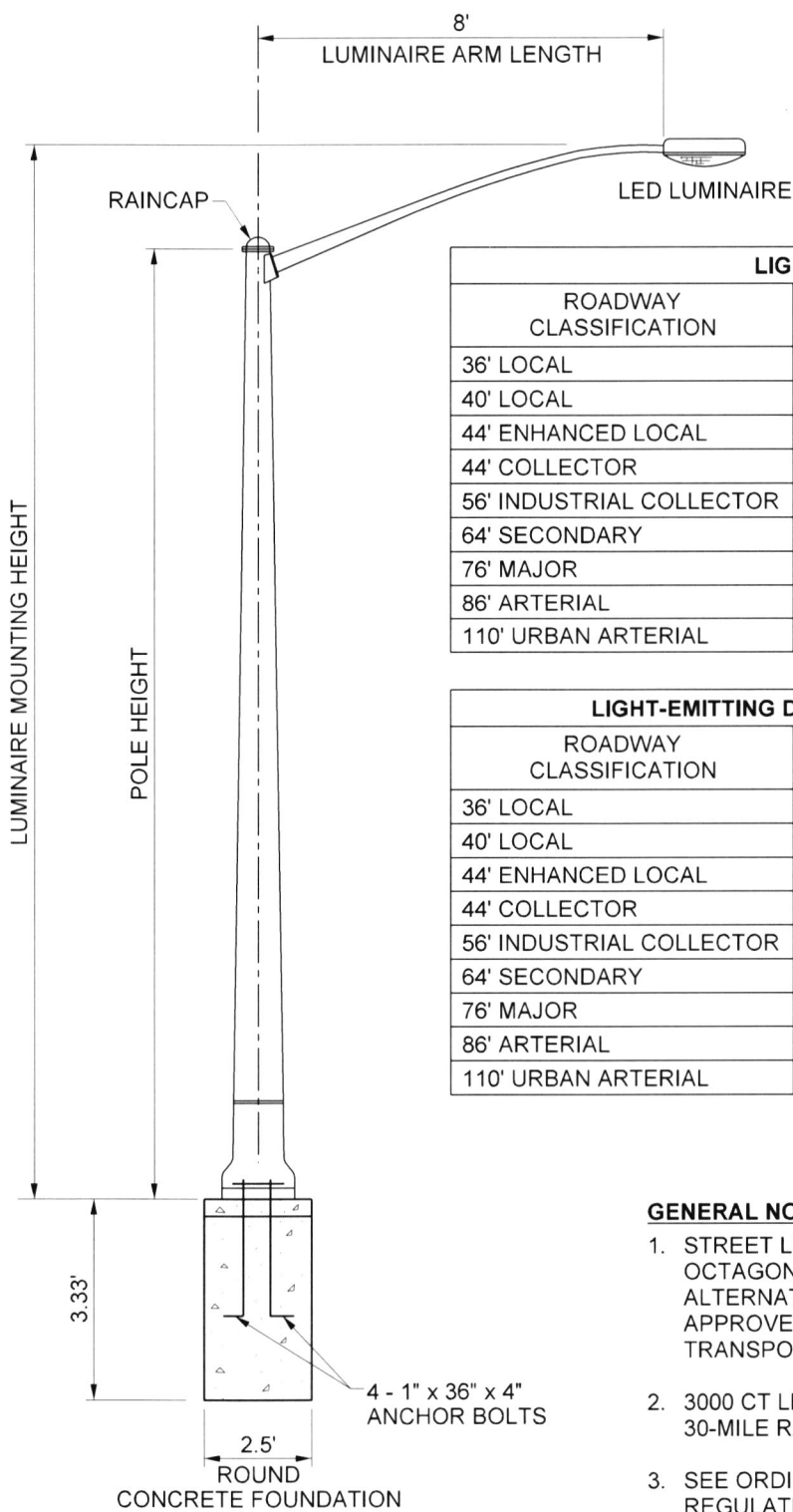

LIGHT POLE TABLE			
ROADWAY CLASSIFICATION	POLE HEIGHT	LUMINAIRE MOUNTING HEIGHT	POLE SPACING
36' LOCAL	23' +/-	26' +/-	200' STAGGERED
40' LOCAL			
44' ENHANCED LOCAL			
44' COLLECTOR			
56' INDUSTRIAL COLLECTOR	28' +/-	31' +/-	
64' SECONDARY	31' +/-	34' +/-	
76' MAJOR			
86' ARTERIAL			
110' URBAN ARTERIAL			

LIGHT-EMITTING DIODE (LED) LUMINAIRE TABLE		
ROADWAY CLASSIFICATION	HPSV EQUIVALENT 4000K CT LED	HPSV EQUIVALENT 3000K CT LED
36' LOCAL	50 W	50 W
40' LOCAL	70 W	
44' ENHANCED LOCAL	100 W	
44' COLLECTOR	150 W	
56' INDUSTRIAL COLLECTOR	150 W	100 W
64' SECONDARY	250 W	150 W
76' MAJOR		
86' ARTERIAL		
110' URBAN ARTERIAL	310 W	200 W

- GENERAL NOTES:**
1. STREET LIGHT POLE SHALL BE TAPERED OCTAGONAL CONCRETE POLE APPROVED BY SCE. ALTERNATE POLE TYPE/MATERIAL SHALL BE APPROVED BY SCE AND THE DIRECTOR OF TRANSPORTATION DEPARTMENT.
  2. 3000 CT LED LUMINAIRE APPLIES TO AREA WITHIN 30-MILE RADIUS OF MT. PALOMAR.
  3. SEE ORDINANCE 348 AND 655 ON LIGHT POLLUTION REGULATION ON PRIVATE LIGHTING.

NOT TO SCALE

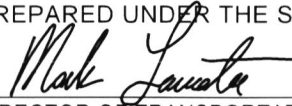
PREPARED UNDER THE SUPERVISION OF:  
  
 DIRECTOR OF TRANSPORTATION  
 MARK LANCASTER, P.E.

11/30/22  
 DATE



COUNTY OF RIVERSIDE

**STREET LIGHTING**  
**(Southern California Edison (SCE) Electric Serving Area)**

**STANDARD No. 1000 (1 OF 3)**

REVISION	DESCRIPTION	MARK	DATE	APPROVED

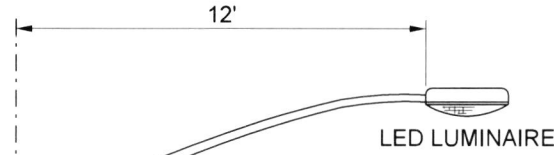

TYPE 15/21  
STANDARD PER  
CALTRANS  
STANDARD  
PLAN ES-6A

HAND HOLE AND  
ANCHORAGE  
DETAIL PER  
CALTRANS  
STANDARD  
PLAN ES-7M

CIDH PILE  
FOUNDATION  
PER CALTRANS  
STANDARD  
PLAN ES-7N

LIGHT POLE TABLE		
ROADWAY CLASSIFICATION	POLE TYPE / HEIGHT	LED
36' LOCAL	CALTRANS TYPE 15 30'	31 W
40' LOCAL		39 W
44' ENHANCED LOCAL		58 W
44' COLLECTOR		98 W
56' INDUSTRIAL COLLECTOR		
64' SECONDARY	CALTRANS TYPE 21 35'	149 W
76' MAJOR		
86' ARTERIAL		
110' URBAN ARTERIAL		

**GENERAL NOTES:**

1. STREET LIGHT POLE, LUMINAIRE ARM, AND FOUNDATION SHALL CONFORM TO CALTRANS STANDARD PLANS AND SPECIFICATIONS. ALTERNATE POLE TYPE/MATERIAL SHALL BE APPROVED BY SCE AND THE DIRECTOR OF TRANSPORTATION DEPARTMENT.
2. POLE SPACING IS 200' STAGGERED.
3. LED WATTAGE IS SUBJECT TO CHANGE BY IID.
4. SEE ORDINANCE 348 AND 655 ON LIGHT POLLUTION REGULATION ON PRIVATE LIGHTING.

NOT TO SCALE

PREPARED UNDER THE SUPERVISION OF:

*Mark Lancaster*  
 DIRECTOR OF TRANSPORTATION  
 MARK LANCASTER, P.E.  
 11/30/22  
 DATE



COUNTY OF RIVERSIDE

**STREET LIGHTING**  
**(Imperial Irrigation District**  
**(IID) Electric Serving Area)**

**STANDARD No. 1000 (2 OF 3)**

REVISION DESCRIPTION	MARK	DATE	APPROVED

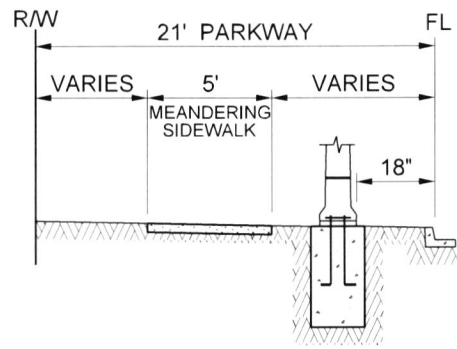
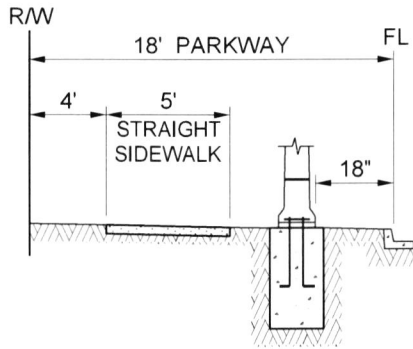
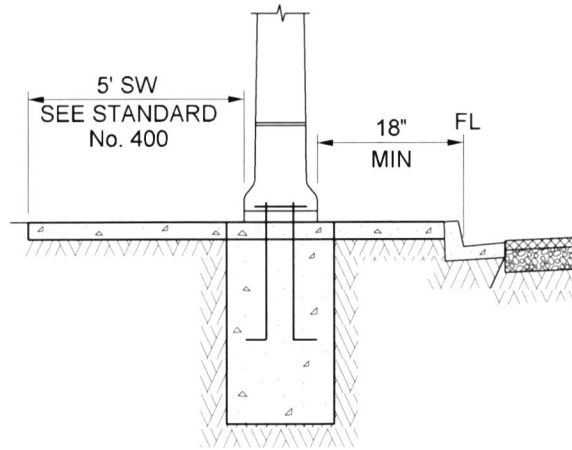

**SIDEWALK SECTIONS**

**NOTE:**

1. WHEN ABUTTING SOIL HAS A HIGH SULFATE CONTENT, USE A MODIFIED CONCRETE MIX AND PLACE 6" MIN CLASS 2 AGGREGATE BASE AND 6 MIL PLASTIC SHEETING UNDER AND AROUND ALL SIDES OF CONCRETE IMPROVEMENTS. FOR EXPANSIVE SOIL, PLACE 6" MIN CLASS 2 AGGREGATE BASE UNDER CONCRETE IMPROVEMENTS AS DIRECTED BY THE ENGINEER. SEE SPECIFICATIONS SECTIONS 16.03 & 16.04 AND STANDARD No. 401 FOR REFERENCE.

NOT TO SCALE

PREPARED UNDER THE SUPERVISION OF:

*Mark Lancaster*

11/30/22  
DATE

DIRECTOR OF TRANSPORTATION  
MARK LANCASTER, P.E.



COUNTY OF RIVERSIDE

**STREET LIGHTING**

REVISION	DESCRIPTION	MARK	DATE	APPROVED

**STANDARD No. 1000 (3 OF 3)**

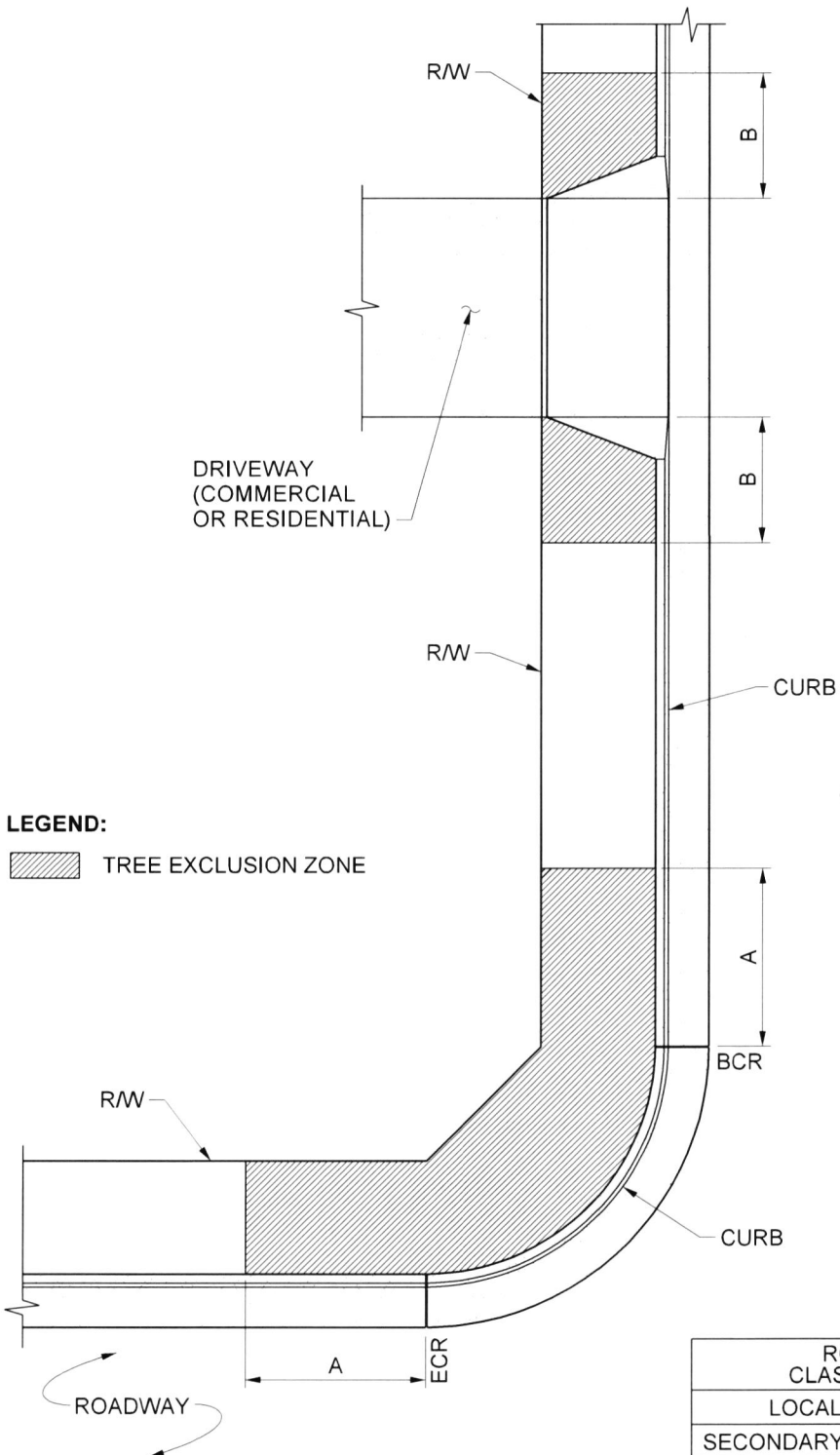

TYPE OF DRIVEWAY	DISTANCE B
RESIDENTIAL	10'
COMMERCIAL	15'

**LEGEND:**  
 TREE EXCLUSION ZONE

ROADWAY CLASSIFICATION	DISTANCE A
LOCAL, COLLECTOR	10'
SECONDARY, MAJOR, ARTERIAL	20'

NOT TO SCALE

PREPARED UNDER THE SUPERVISION OF:

*Mark Lancaster*  
 DIRECTOR OF TRANSPORTATION  
 MARK LANCASTER, P.E.  
 DATE 11/30/22



COUNTY OF RIVERSIDE  
**TREE SETBACKS AT  
 CORNER CUT-BACKS  
 AND DRIVEWAYS**

REVISION DESCRIPTION	MARK	DATE	APPROVED

**STANDARD No. 1101**

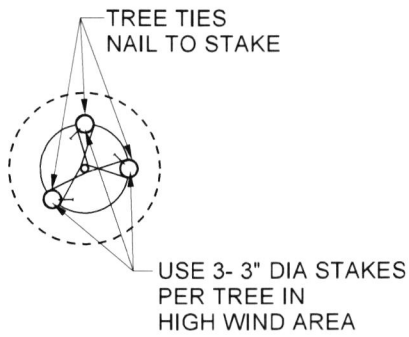

**HIGH WIND SECTION "A-A"**

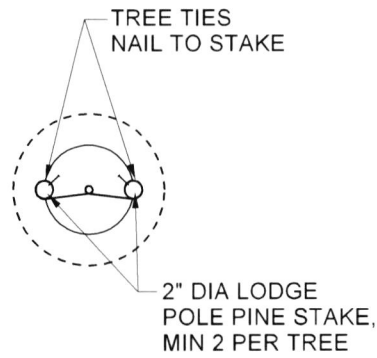

**SECTION "A-A"**

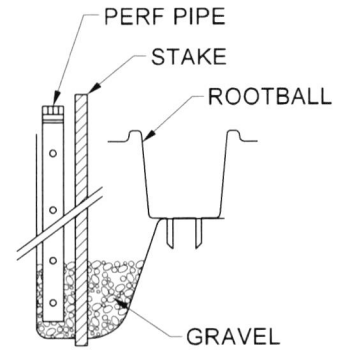

**DRAIN PIPE DETAIL**  
4" SCH 40 PERF PIPE  
1 PER TREE

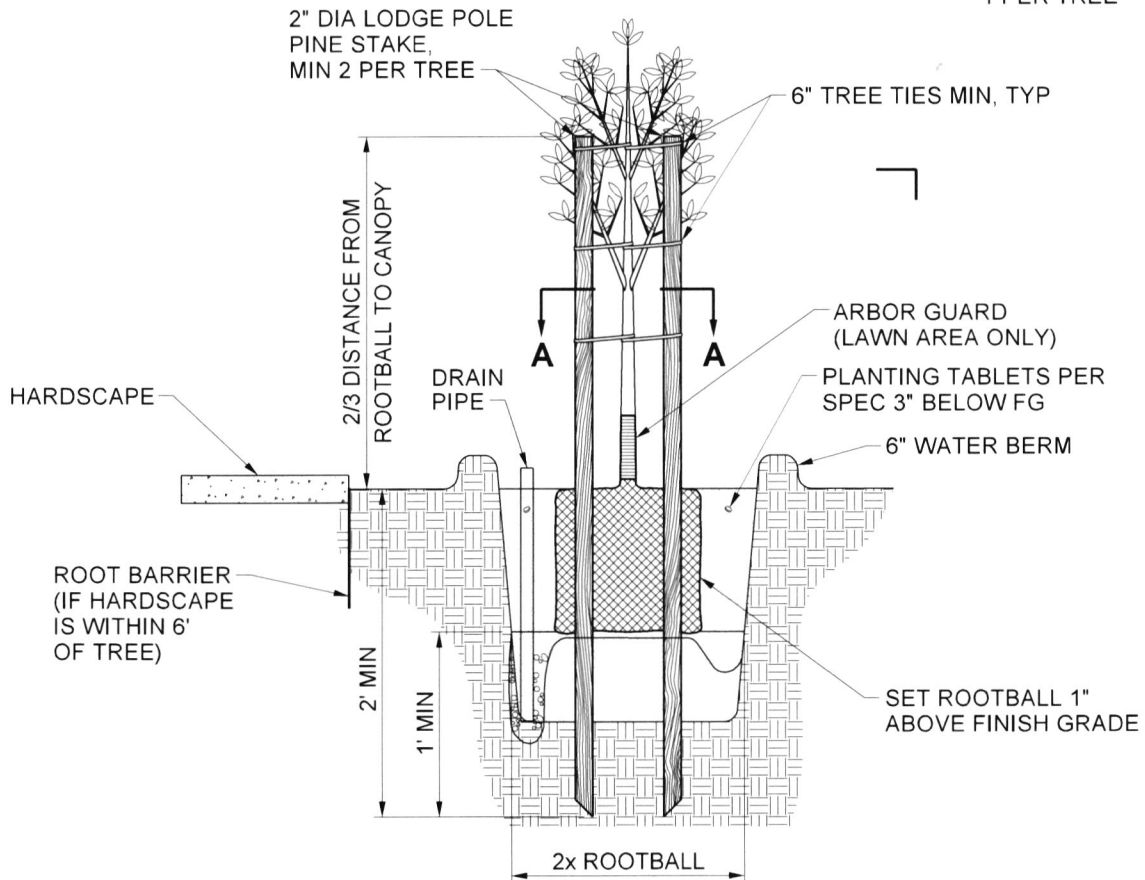

**NOTES:**

1. STAKE TREE PERPENDICULAR TO DIRECTION OF PREVAILING WIND.
2. MULTI-STEM TREES SHALL HAVE 3 STAKES
3. 48" BOX OR GREATER TO USE GUY WIRES.
4. DETAIL FOR USE IN AREAS WITHOUT SEPARATE APPROVED LANDSCAPE PLANS.

NOT TO SCALE

PREPARED UNDER THE SUPERVISION OF:

*Mark Lancaster* 11/30/22  
DIRECTOR OF TRANSPORTATION DATE  
MARK LANCASTER, P.E.



COUNTY OF RIVERSIDE

**TREE STAKING DETAIL**

**STANDARD No. 1102**

REVISION	DESCRIPTION	MARK	DATE	APPROVED

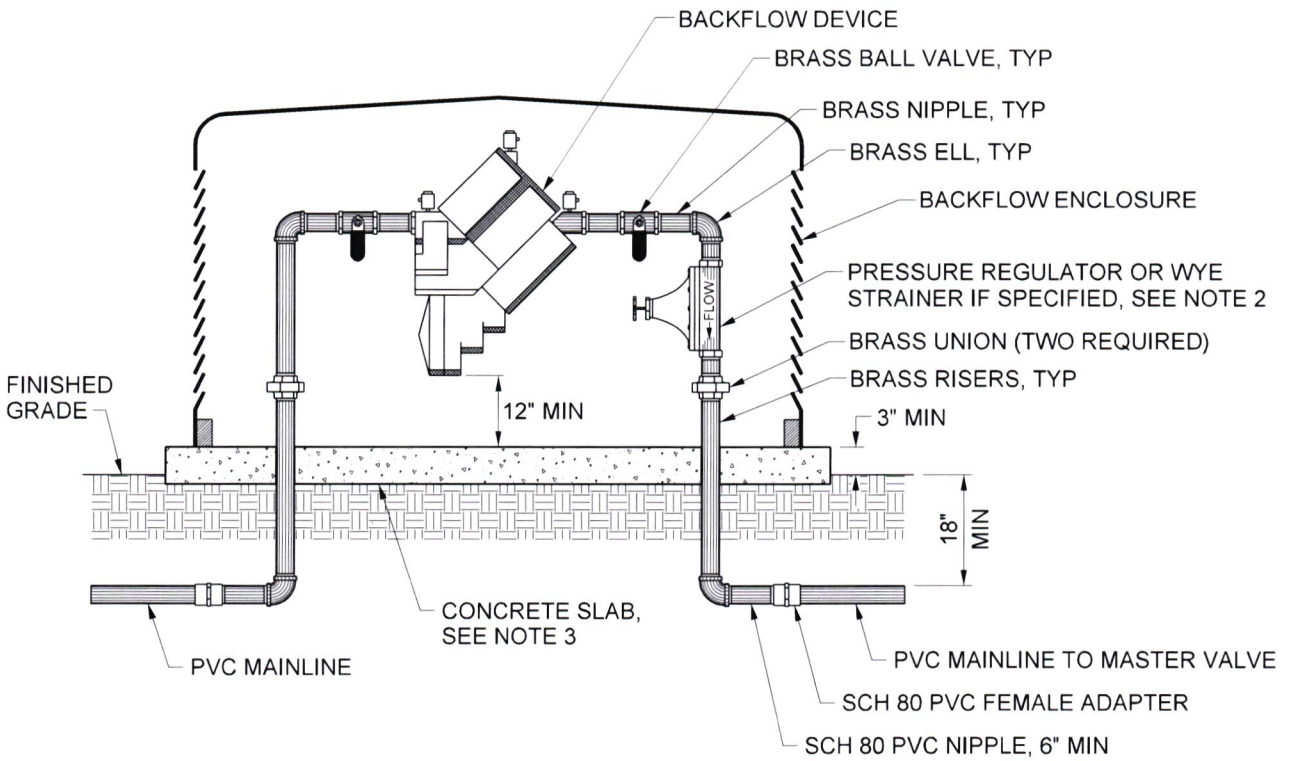

**NOTES:**

1. INSTALL PER LOCAL WATER DISTRICT STANDARD DETAIL.
2. INSTALL WYE STRAINER AND/OR PRESSURE REGULATOR IF SPECIFIED AND ALLOWED.
3. CONCRETE PAD LENGTH AND WIDTH SHALL BE 6" GREATER THAN SIZE OF BACKFLOW CAGE. CONCRETE MINIMUM CEMENTITIOUS MATERIAL CONTENT = 505 LB / CU YD.
4. VIT QUICKPAD IS ALLOWED. BACKFLOW CAGE SHALL BE STAINLESS STEEL OR ALUMINUM BY VIT.
5. FOR USE IN AREAS WITHOUT SEPARATE APPROVED LANDSCAPE PLANS.

NOT TO SCALE

PREPARED UNDER THE SUPERVISION OF:

*Mark Lancaster*  
 DIRECTOR OF TRANSPORTATION  
 MARK LANCASTER, P.E.      11/30/22  
 DATE



COUNTY OF RIVERSIDE

**BACKFLOW PREVENTION  
 DEVICE INSTALLATION**

**STANDARD No. 1103**

REVISION	DESCRIPTION	MARK	DATE	APPROVED

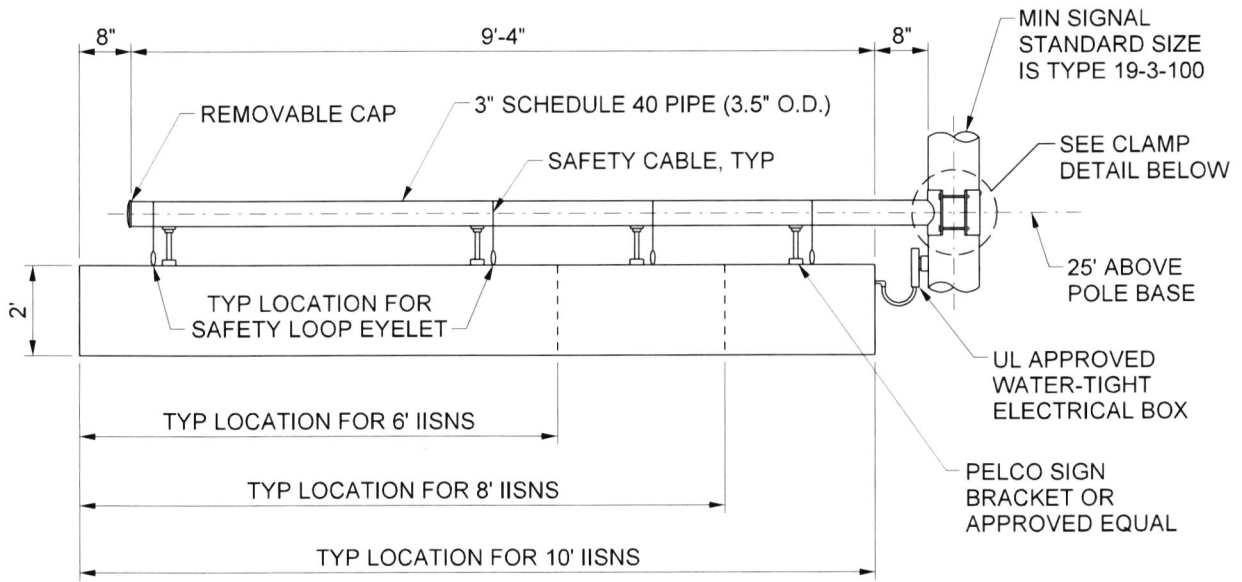

**10' IISNS STRAIGHT MAST ARM MOUNTING DETAIL**

NOTE:  
SIGN LOCATION MAY VARY DEPENDING  
ON HEIGHT OF SIGNAL MAST ARM.

SPECIFY TRAFFIC  
SIGNAL POLE  
DIA AT 25'  
ABOVE BASE

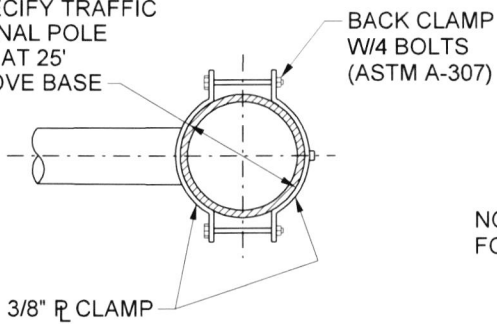

**TOP VIEW**

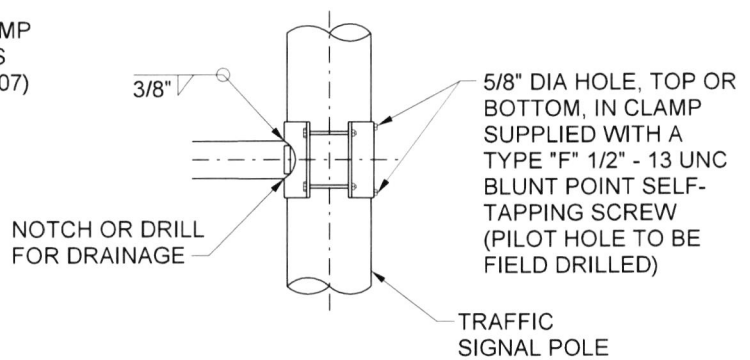

**ELEVATION**

**CLAMP DETAIL**

NOT TO SCALE

PREPARED UNDER THE SUPERVISION OF:

*Mark Lancaster*  
DIRECTOR OF TRANSPORTATION  
MARK LANCASTER, P.E.

11/30/22  
DATE

REVISION	DESCRIPTION	MARK	DATE	APPROVED



COUNTY OF RIVERSIDE

**IISNS MAST ARM  
DETAIL**

**STANDARD No. 1200**



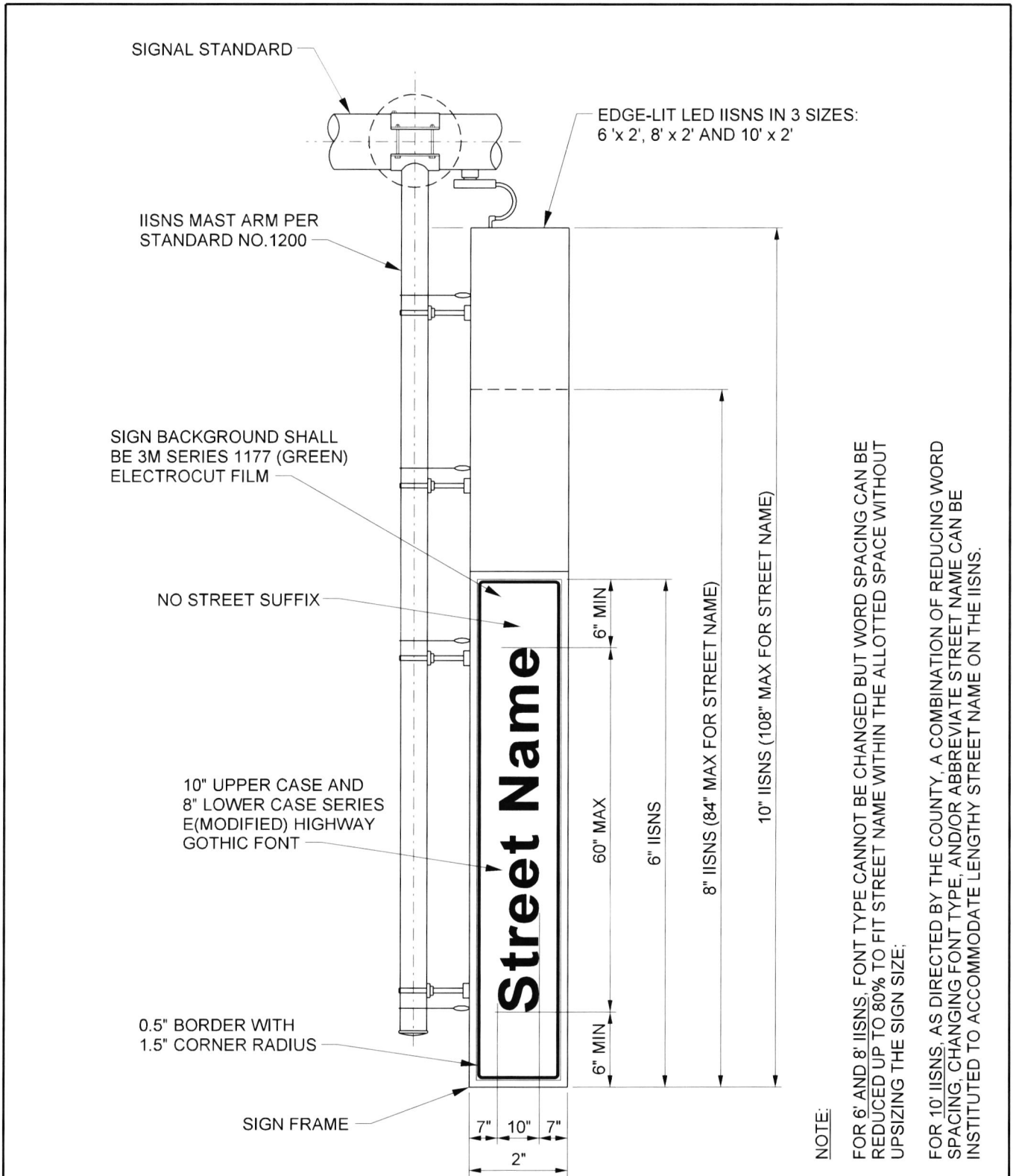

**NOTE:**  
 FOR 6' AND 8' IISNS, FONT TYPE CANNOT BE CHANGED BUT WORD SPACING CAN BE REDUCED UP TO 80% TO FIT STREET NAME WITHIN THE ALLOTTED SPACE WITHOUT UPSIZING THE SIGN SIZE;  
 FOR 10' IISNS, AS DIRECTED BY THE COUNTY, A COMBINATION OF REDUCING WORD SPACING, CHANGING FONT TYPE, AND/OR ABBREVIATE STREET NAME CAN BE INSTITUTED TO ACCOMMODATE LENGTHY STREET NAME ON THE IISNS.

NOT TO SCALE

PREPARED UNDER THE SUPERVISION OF:

*Mark Lancaster* 11/30/22  
 DIRECTOR OF TRANSPORTATION DATE  
 MARK LANCASTER, P.E.

REVISION	DESCRIPTION	MARK	DATE	APPROVED



COUNTY OF RIVERSIDE

**IISNS DETAIL**

**STANDARD No. 1201**

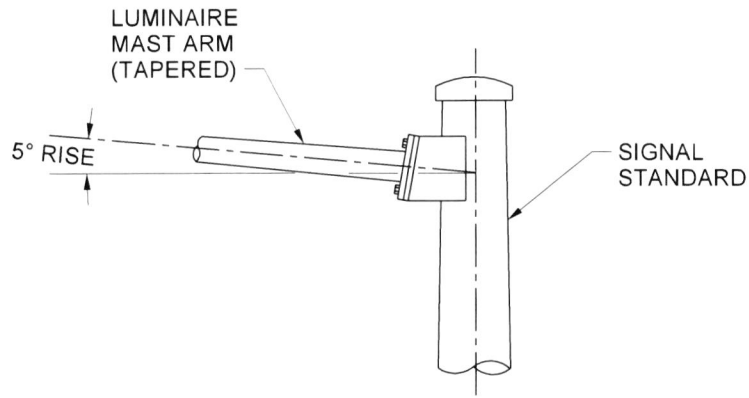

**STRAIGHT LUMINAIRE MAST ARM DETAIL**

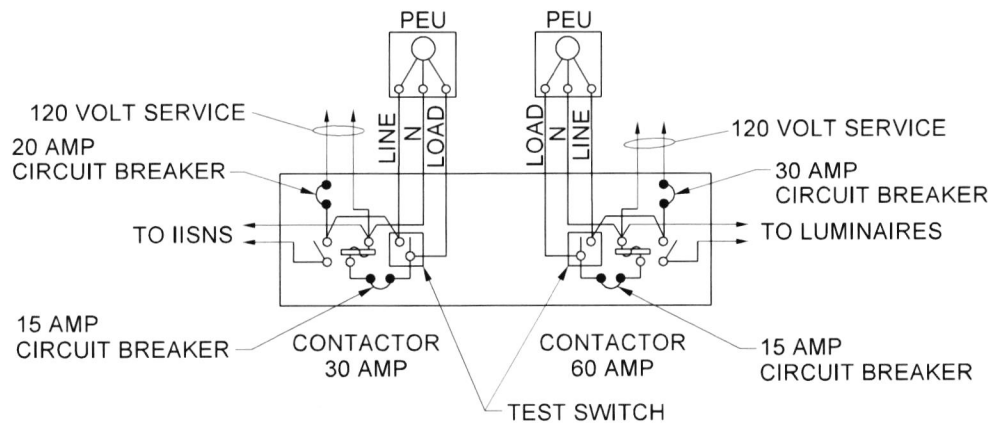

**DUAL PEC WIRING DIAGRAM**



**MOUNTING CLAMP FOR EVP OPTICAL DETECTOR**

NOT TO SCALE

PREPARED UNDER THE SUPERVISION OF:

*Mark Lancaster*  
 DIRECTOR OF TRANSPORTATION  
 MARK LANCASTER, P.E.

11/30/22  
 DATE



COUNTY OF RIVERSIDE

**TRAFFIC SIGNAL  
 DETAIL**

REVISION	DESCRIPTION	MARK	DATE	APPROVED

STANDARD No. 1202 (1 OF 3)

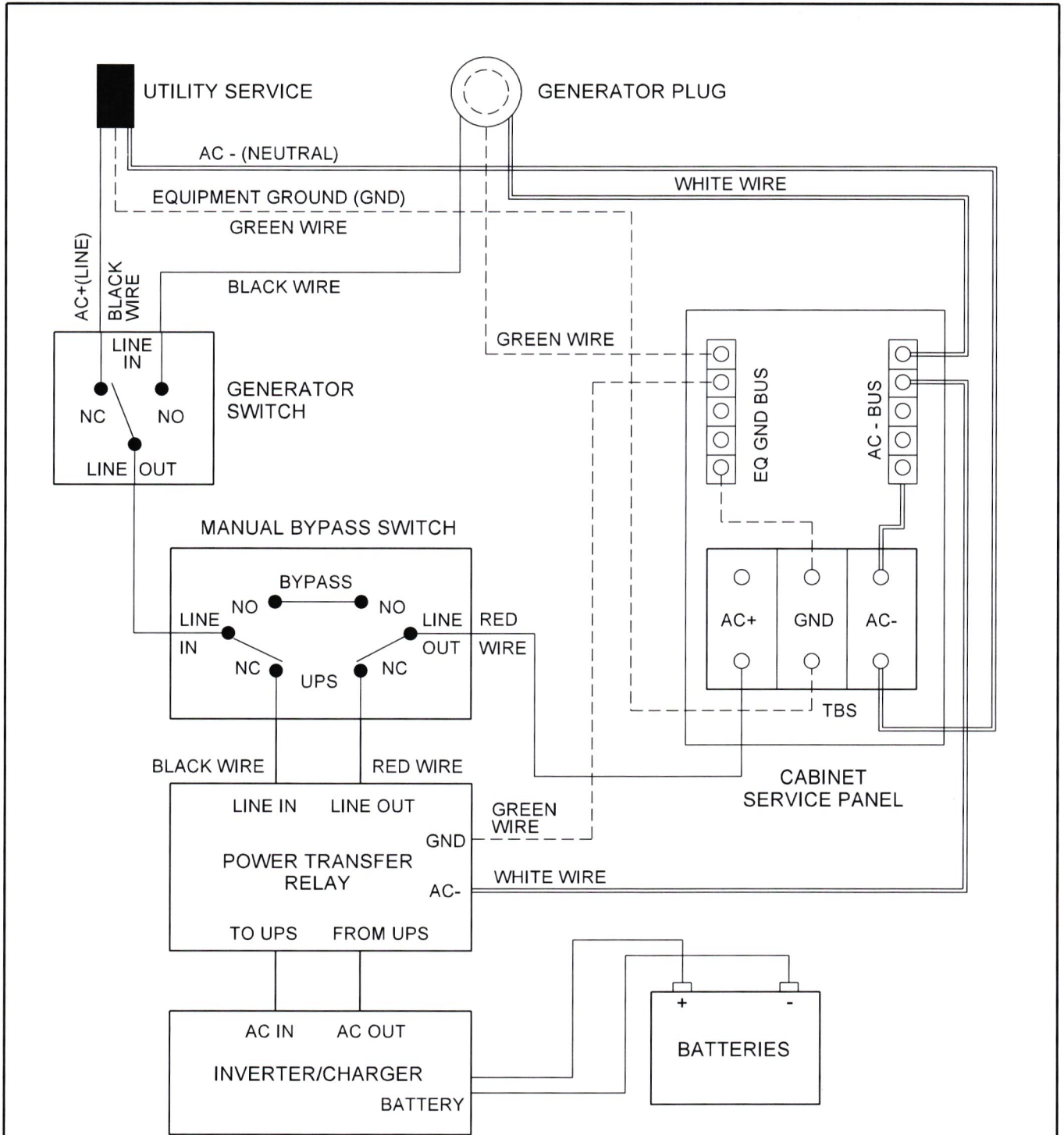

**BATTERY BACKUP SYSTEM SCHEMATIC DIAGRAM**

NOT TO SCALE

PREPARED UNDER THE SUPERVISION OF:

*Mark Lancaster* 11/30/22  
 DIRECTOR OF TRANSPORTATION DATE  
 MARK LANCASTER, P.E.

REVISION	DESCRIPTION	MARK	DATE	APPROVED



COUNTY OF RIVERSIDE

**TRAFFIC SIGNAL  
 DETAIL**

**STANDARD No. 1202 (2 OF 3)**

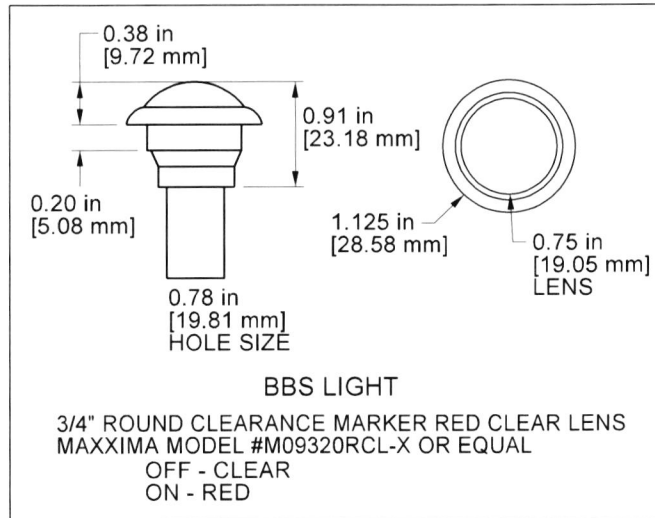
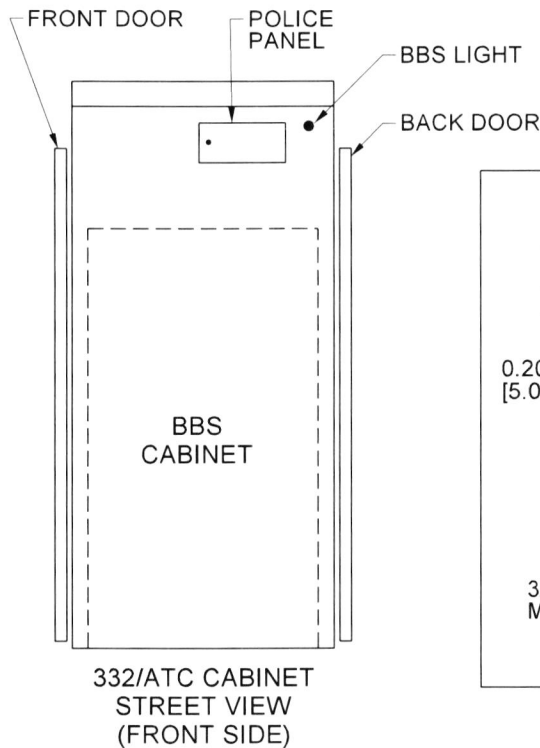
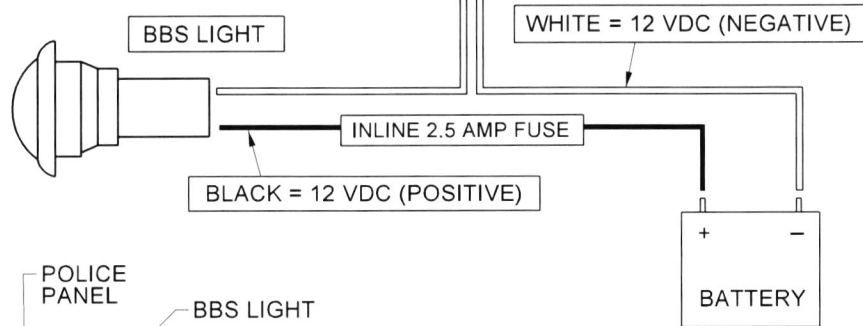
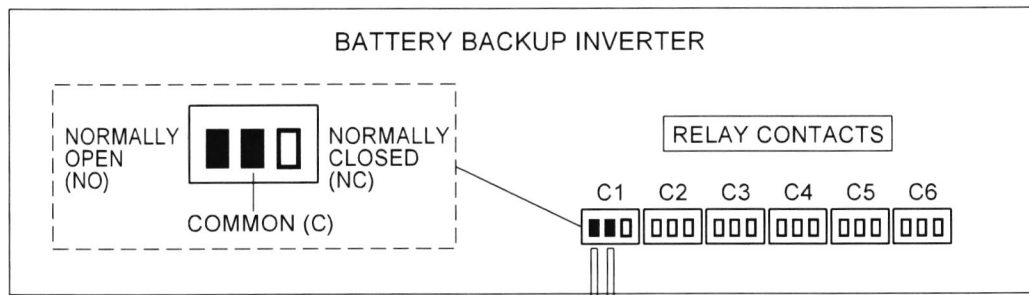

### BATTERY BACKUP SYSTEM (BBS) LIGHT

NOT TO SCALE

PREPARED UNDER THE SUPERVISION OF:

*Mark Lancaster*  
DIRECTOR OF TRANSPORTATION  
MARK LANCASTER, P.E.

11/30/22  
DATE

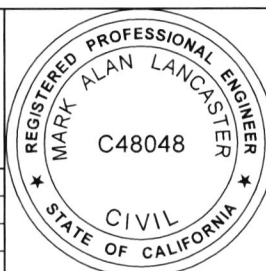

COUNTY OF RIVERSIDE

**TRAFFIC SIGNAL  
DETAIL**

REVISION	DESCRIPTION	MARK	DATE	APPROVED

STANDARD No. 1202 (3 OF 3)

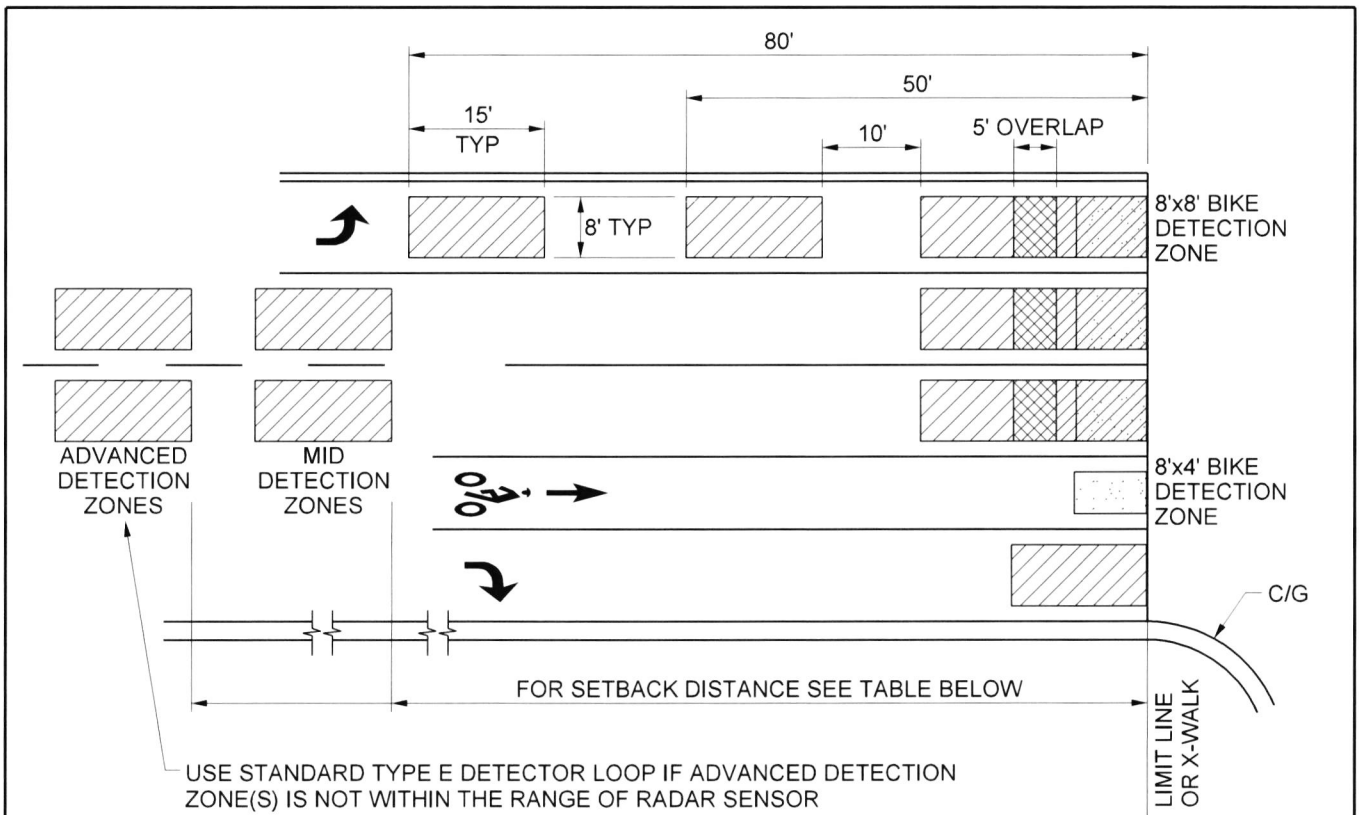

**VIDEO/RADAR DETECTION ZONE DETAIL**

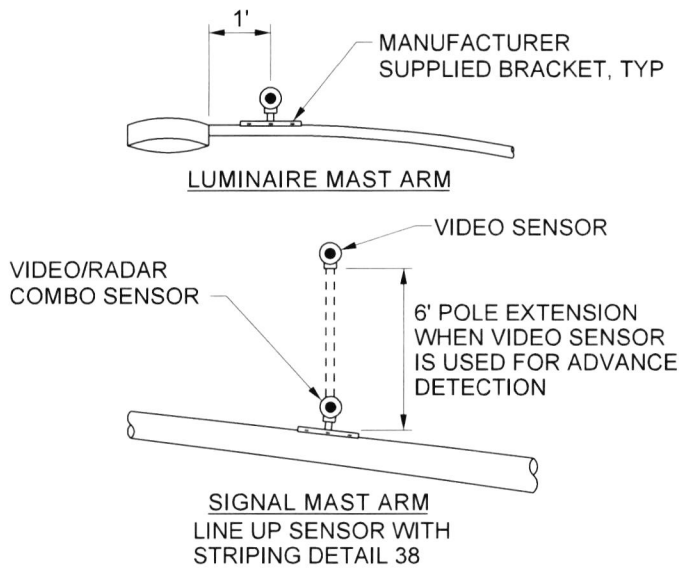

**SENSOR MOUNTING DETAIL**

ADVANCE AND MID-DETECTION ZONES SETBACK DISTANCE FROM LIMIT LINE

SPEED	SETBACK	
	ADVANCED	MID (FT)
25 MPH	105'	-
30 MPH	140'	-
35 MPH	185'	100'
40 MPH	230'	120'
45 MPH	285'	150'
50 MPH	345'	180'
55 MPH	405'	210'
60 MPH	475'	245'
65 MPH	550'	280'

NOT TO SCALE

PREPARED UNDER THE SUPERVISION OF:

*Mark Lancaster*  
 DIRECTOR OF TRANSPORTATION  
 MARK LANCASTER, P.E.  
 11/30/22  
 DATE

REVISION	DESCRIPTION	MARK	DATE	APPROVED



COUNTY OF RIVERSIDE

**VIDEO/RADAR DETECTION DETAIL**

**STANDARD No. 1205**

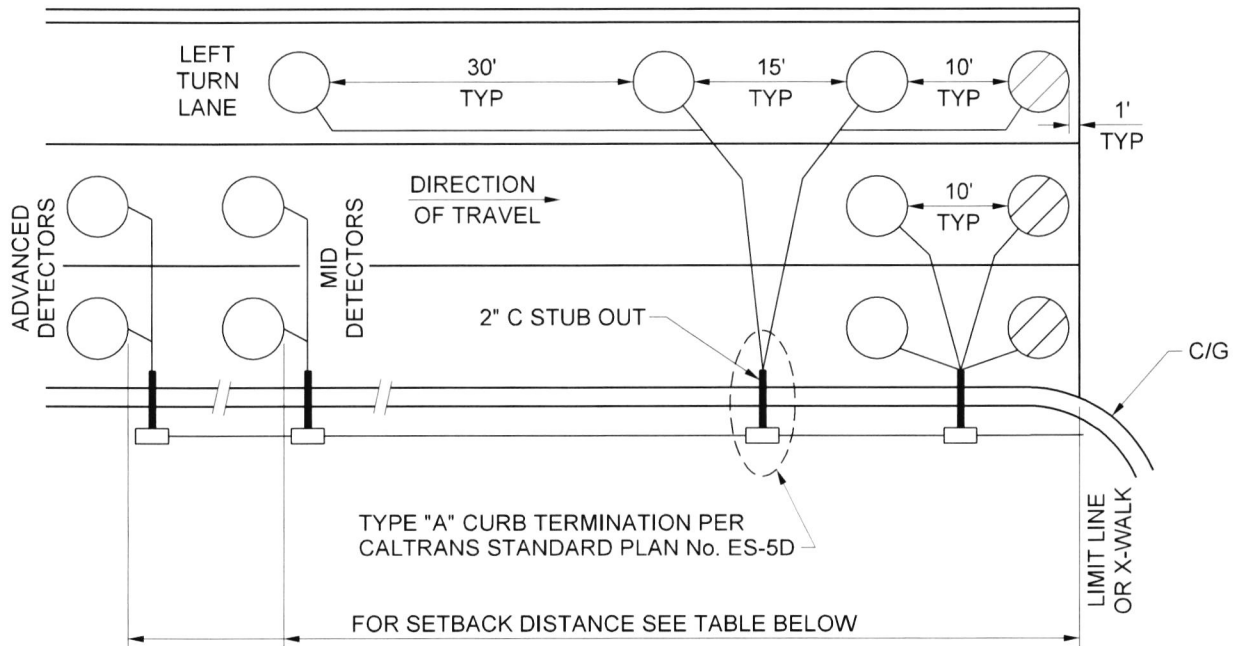

**LOOP DETECTOR PLACEMENT DETAIL**

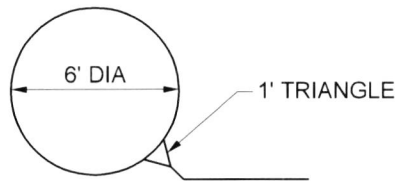

TYPE E

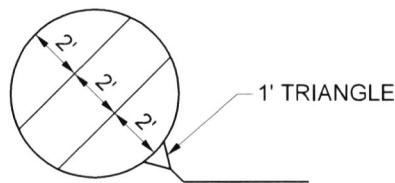

TYPE E (MODIFIED)

**LOOP DETECTOR SAWCUT DETAIL**

ADVANCE AND MID-DETECTION ZONES SETBACK DISTANCE FROM LIMIT LINE

SPEED	SETBACK	
	ADVANCED	MID (FT)
25 MPH	105'	-
30 MPH	140'	-
35 MPH	185'	100'
40 MPH	230'	120'
45 MPH	285'	150'
50 MPH	345'	180'
55 MPH	405'	210'
60 MPH	475'	245'
65 MPH	550'	280'

NOT TO SCALE

PREPARED UNDER THE SUPERVISION OF:

*Mark Lancaster*  
 DIRECTOR OF TRANSPORTATION  
 MARK LANCASTER, P.E.

11/30/22  
 DATE



COUNTY OF RIVERSIDE

**LOOP DETECTOR  
 DETAIL**

**STANDARD No. 1206**

REVISION DESCRIPTION	MARK	DATE	APPROVED



ADD ADDITIONAL  
DETECTION ZONE  
WHEN CURB LANE  
IS 20' OR GREATER

**MINOR**

BIKE  
DETECTION

**STREET**

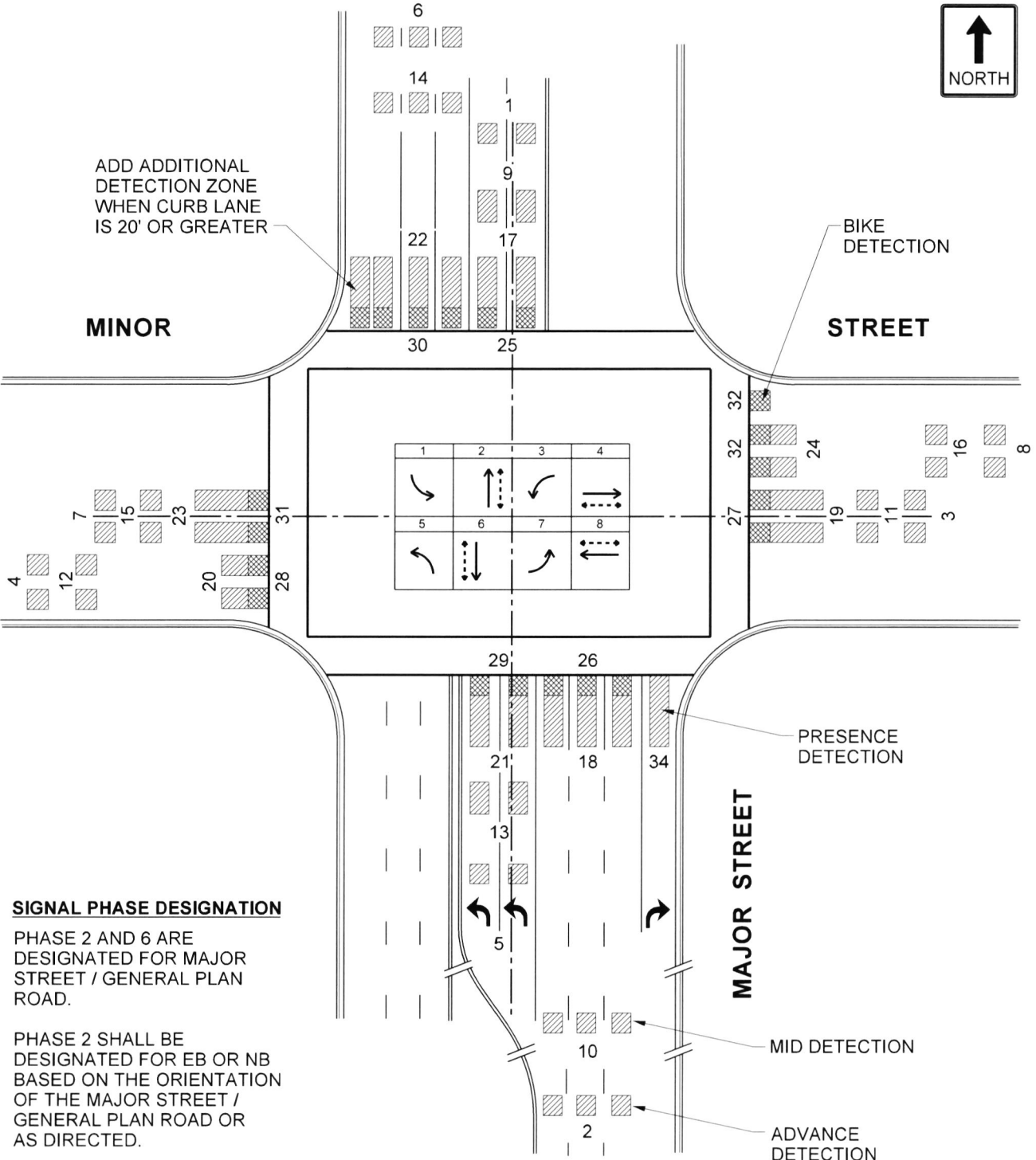

**SIGNAL PHASE DESIGNATION**

PHASE 2 AND 6 ARE DESIGNATED FOR MAJOR STREET / GENERAL PLAN ROAD.

PHASE 2 SHALL BE DESIGNATED FOR EB OR NB BASED ON THE ORIENTATION OF THE MAJOR STREET / GENERAL PLAN ROAD OR AS DIRECTED.

PRESENCE  
DETECTION

**MAJOR STREET**

MID DETECTION

ADVANCE  
DETECTION

NOT TO SCALE

PREPARED UNDER THE SUPERVISION OF:

*Mark Lancaster*

DIRECTOR OF TRANSPORTATION  
MARK LANCASTER, P.E.

11/30/22  
DATE



COUNTY OF RIVERSIDE

**ATS DETECTION  
INPUT ASSIGNMENTS**

STANDARD No. 1207 (1 OF 2)

REVISION	DESCRIPTION	MARK	DATE	APPROVED

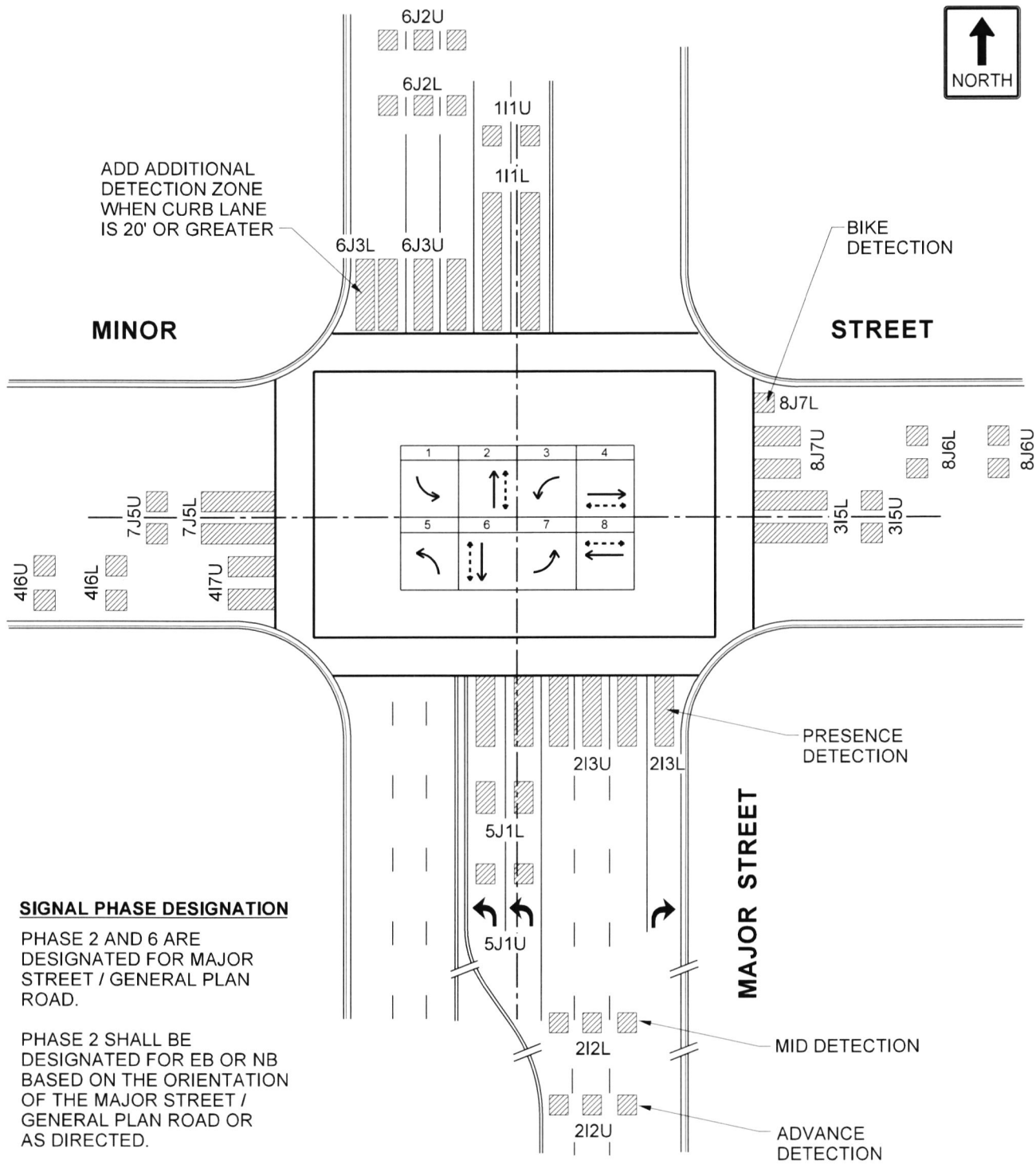

**SIGNAL PHASE DESIGNATION**

PHASE 2 AND 6 ARE DESIGNATED FOR MAJOR STREET / GENERAL PLAN ROAD.

PHASE 2 SHALL BE DESIGNATED FOR EB OR NB BASED ON THE ORIENTATION OF THE MAJOR STREET / GENERAL PLAN ROAD OR AS DIRECTED.

NOT TO SCALE

PREPARED UNDER THE SUPERVISION OF:

*Mark Lancaster*

11/30/22  
DATE

DIRECTOR OF TRANSPORTATION  
MARK LANCASTER, P.E.



COUNTY OF RIVERSIDE

**170 & 2070 DETECTION INPUT ASSIGNMENTS**

STANDARD No. 1207 (2 OF 2)

REVISION	DESCRIPTION	MARK	DATE	APPROVED



**STRIPING CONSTRUCTION NOTES:**

- ## INSTALL (STRIPING TYPE) PER CALTRANS STD PLAN (PLAN NO.), DETAIL (##).
- L INSTALL 100'- 6" WHITE LEAD-IN LANE LINE WITH 5-TYPE G RPM @ 25' OC, 2" FROM RIGHT EDGE OF STRIPE IN DIRECTION OF TRAVEL
- LL INSTALL 12" WHITE LINE LIMIT PER CALTRANS STD PLAN A24E
- PM INSTALL PAVEMENT MARKINGS AS SHOWN, UNLESS NOTED OTHERWISE
- RM REMOVE CONFLICTING TRAFFIC STRIPES, PAVEMENT MARKERS AND/OR PAVEMENT MARKINGS
- XW INSTALL 12" CROSSWALK STRIPES PER CALTRANS STD PLAN A24F, WHITE UNLESS NOTED OTHERWISE

INSTALL 2ND ARROW IN MIDDLE WHEN POCKET LENGTH IS 150' OR LONGER

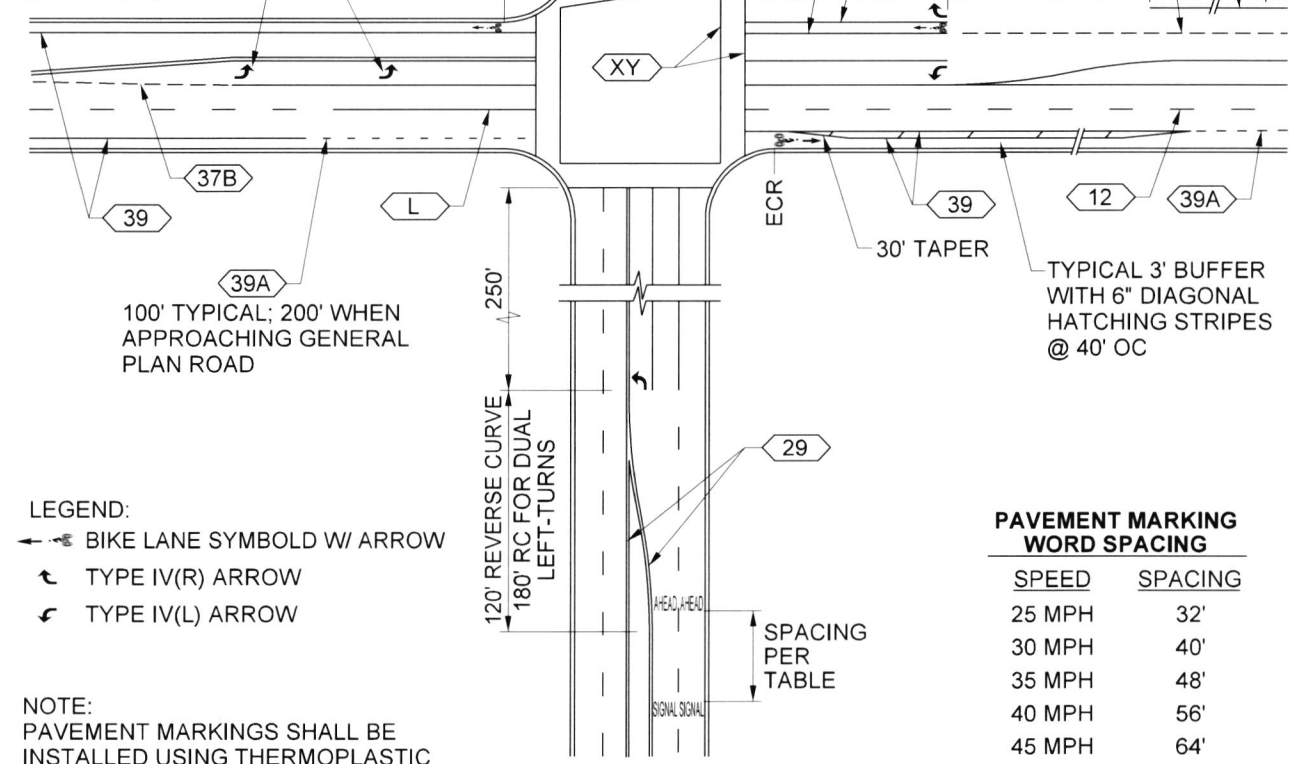

**LEGEND:**

- BIKE LANE SYMBOL W/ ARROW
- TYPE IV(R) ARROW
- TYPE IV(L) ARROW

NOTE:  
PAVEMENT MARKINGS SHALL BE INSTALLED USING THERMOPLASTIC MATERIAL UNLESS NOTED OTHERWISE.

**PAVEMENT MARKING WORD SPACING**

SPEED	SPACING
25 MPH	32'
30 MPH	40'
35 MPH	48'
40 MPH	56'
45 MPH	64'
50 MPH	72'
≥ 55 MPH	80'

\* SEE COUNTY ROAD IMPROVEMENT STANDARD FOR LANE WIDTH REQUIREMENTS

NOT TO SCALE

PREPARED UNDER THE SUPERVISION OF:

*Mark Lancaster* 11/30/22  
 DIRECTOR OF TRANSPORTATION DATE  
 MARK LANCASTER, P.E.

REVISION	DESCRIPTION	MARK	DATE	APPROVED



COUNTY OF RIVERSIDE

**STRIPING DETAILS AND CONSTRUCTION NOTES**

STANDARD No. 1210

# MAJOR STREET

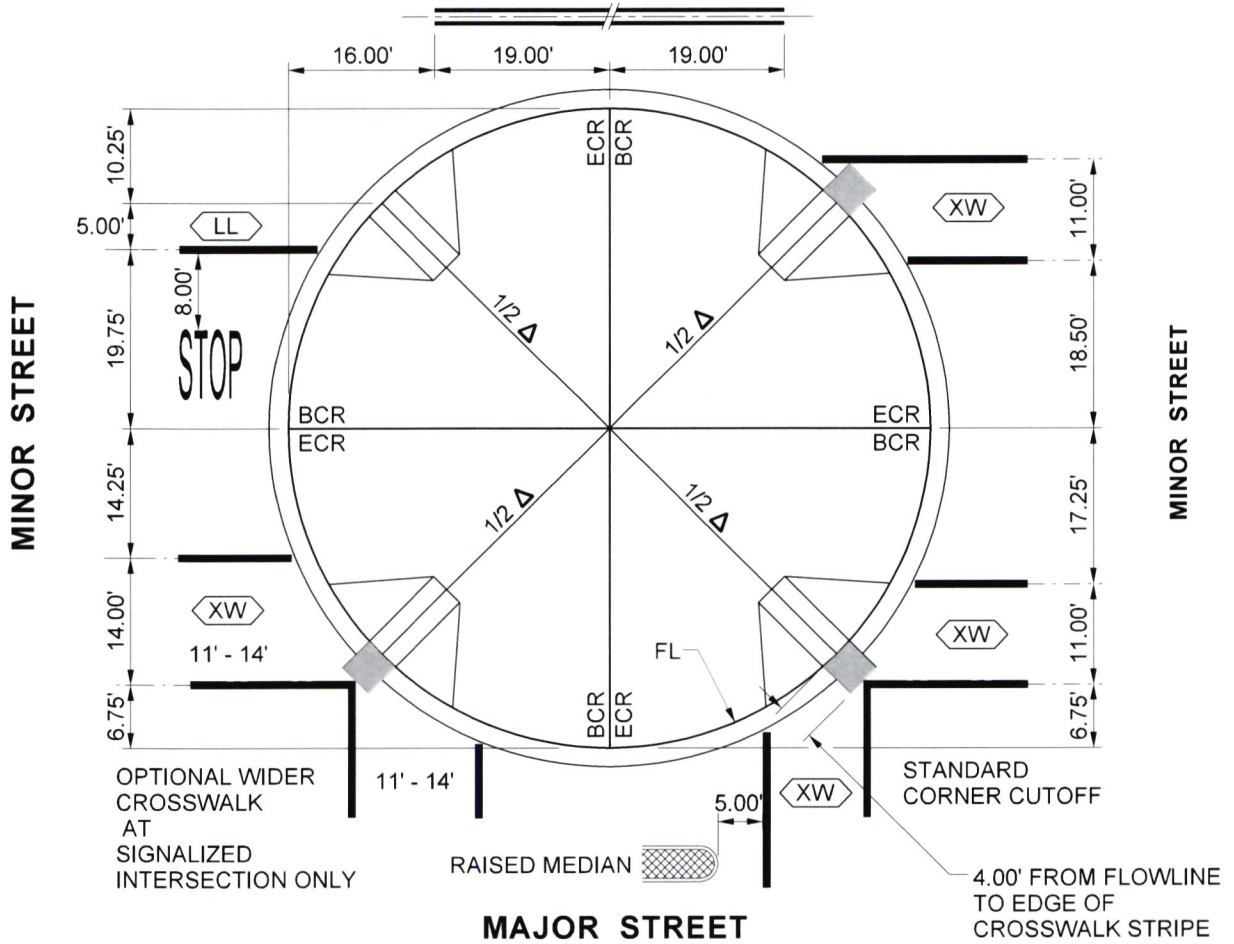

## 35' RADIUS CURB RETURN

**LEGEND:**

■ MIN 4' x 4' LANDING WITHIN THE CROSSWALK

**NOTES:**

1. KEEP CROSSWALK AND LIMIT LINE MARKING OFF GUTTER PLATE.
2. PLACE 4" BLACK CONTRAST STRIPE ON BOTH SIDES OF XW OR LL WHEN XW OR LL WAS INSTALLED OVER CONCRETE PAVEMENT OR CROSS GUTTER.

NOT TO SCALE

PREPARED UNDER THE SUPERVISION OF:

*Mark Lancaster*  
 DIRECTOR OF TRANSPORTATION  
 MARK LANCASTER, P.E.

11/30/22  
 DATE



COUNTY OF RIVERSIDE

### CROSSWALK AND LIMIT LINE DETAIL

STANDARD No. 1211

REVISION	DESCRIPTION	MARK	DATE	APPROVED



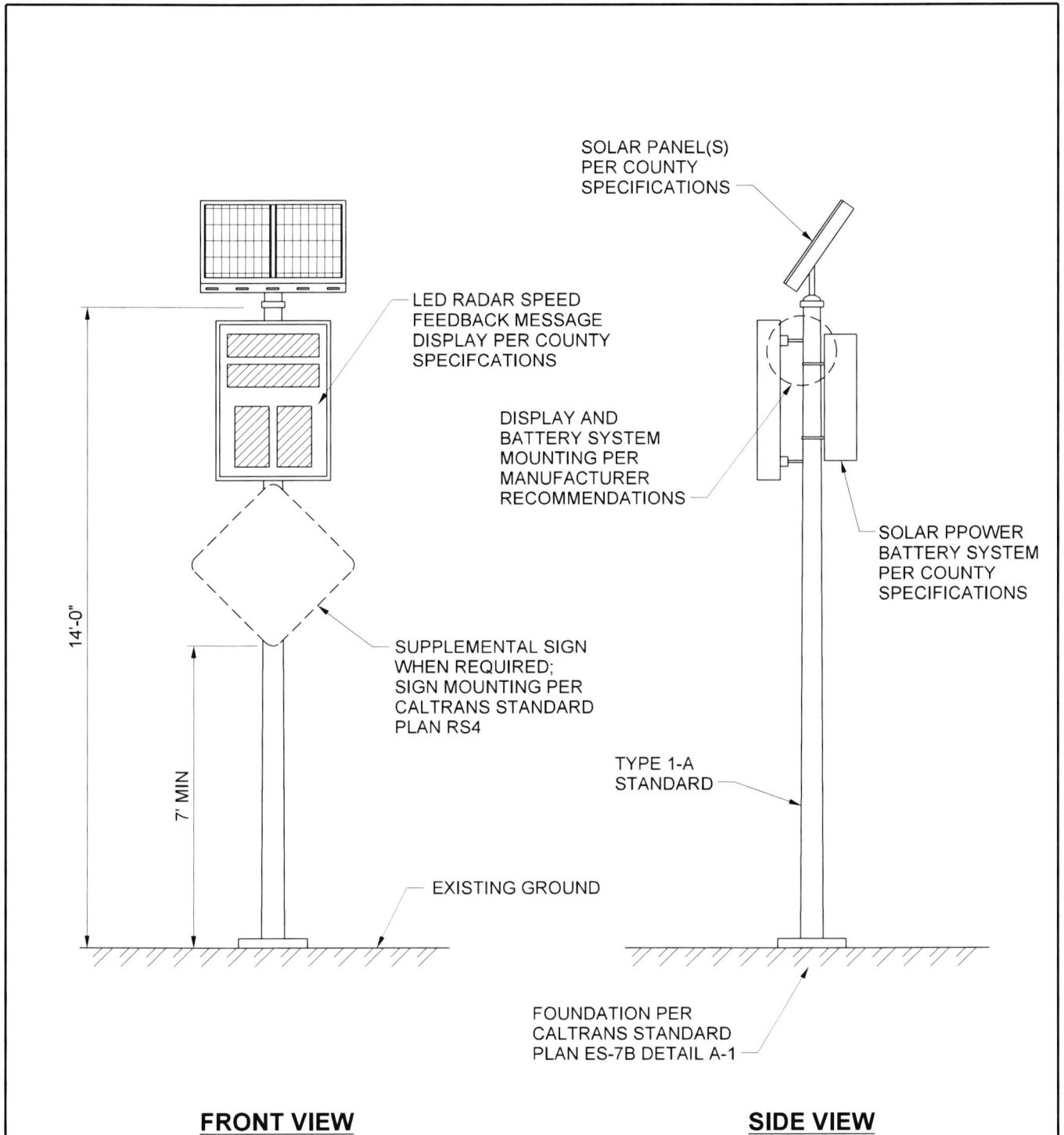

**FRONT VIEW**

**SIDE VIEW**

NOT TO SCALE

PREPARED UNDER THE SUPERVISION OF:

*Mark Lancaster*  
 DIRECTOR OF TRANSPORTATION  
 MARK LANCASTER, P.E.

11/30/22  
 DATE



COUNTY OF RIVERSIDE

**SOLAR POWERED RADAR  
 SPEED FEEDBACK SIGN**  
 - LOCAL ROAD

REVISION	DESCRIPTION	MARK	DATE	APPROVED

**STANDARD No. 1216**

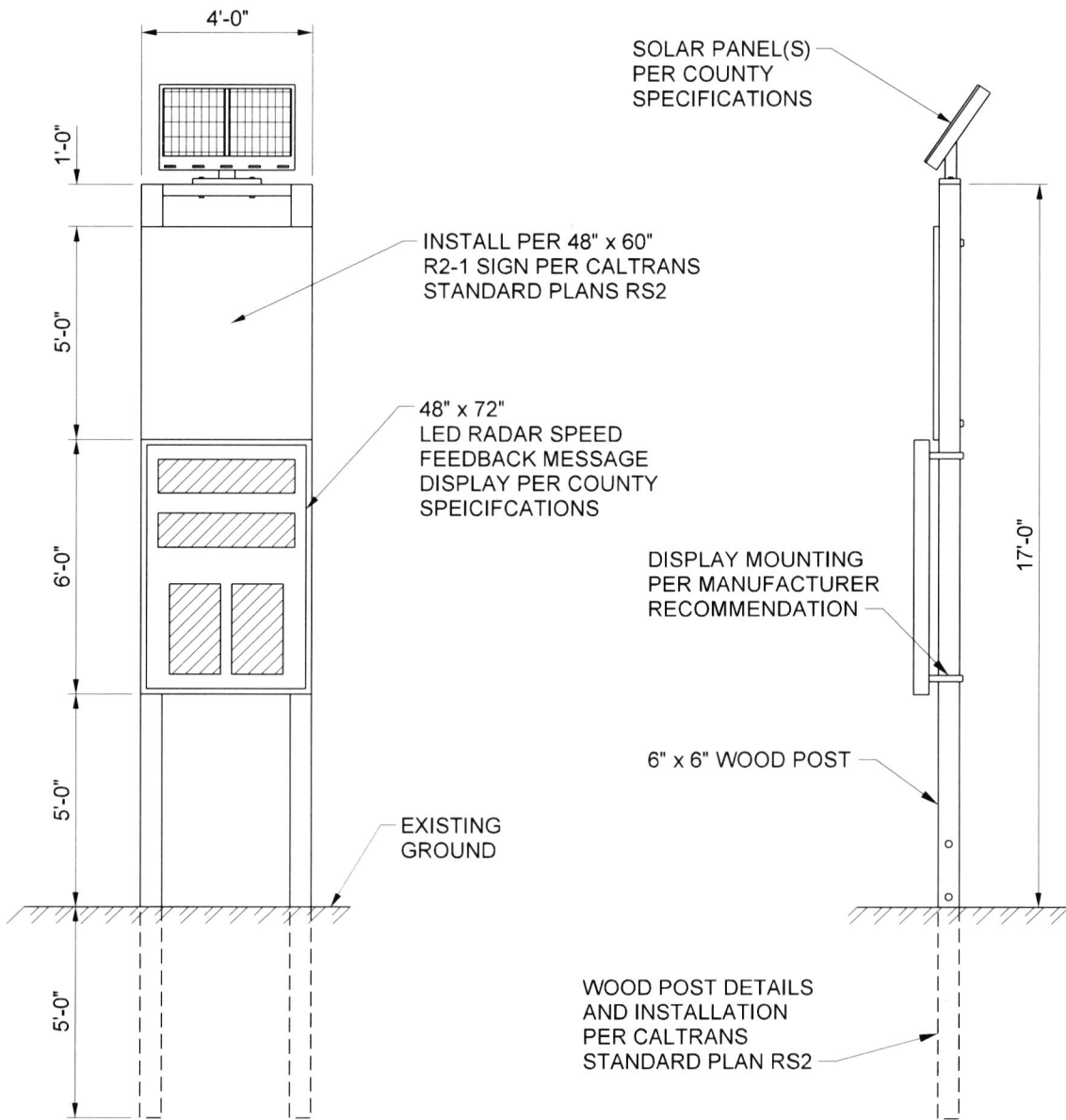

**FRONT VIEW**

**SIDE VIEW**

NOT TO SCALE

PREPARED UNDER THE SUPERVISION OF:

*Mark Lancaster*  
 DIRECTOR OF TRANSPORTATION  
 MARK LANCASTER, P.E.

11/30/22  
 DATE



COUNTY OF RIVERSIDE

**SOLAR POWERED RADAR  
 SPEED FEEDBACK SIGN**  
 - HIGHWAY

REVISION	DESCRIPTION	MARK	DATE	APPROVED

**STANDARD No. 1217**

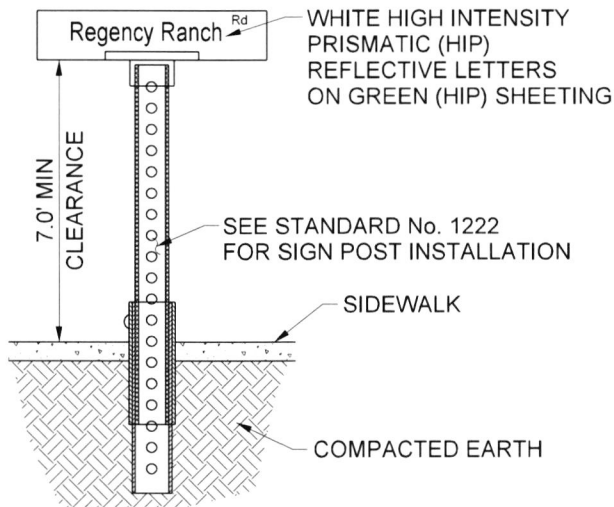

**NOTES:**

1. WHEN ONE OF THE INTERSECTING ROADWAYS HAS AN ULTIMATE PAVED WIDTH OR CURBED WIDTH GREATER THAN 60 FEET, STANDARD No. 1220 SHALL BE USED.
2. WHEN ALL INTERSECTING STREETS HAVE ULTIMATE PAVED WIDTHS OR CURBED WIDTHS OF 60 FEET OR LESS, AND THEY ARE NOT GENERAL PLAN ROADS, USE STANDARD No. 1221.
3. MORE THAN FOUR STREET NAME SIGNS MAY BE REQUIRED AT INTERSECTIONS WITH MORE THAN FOUR LEGS.

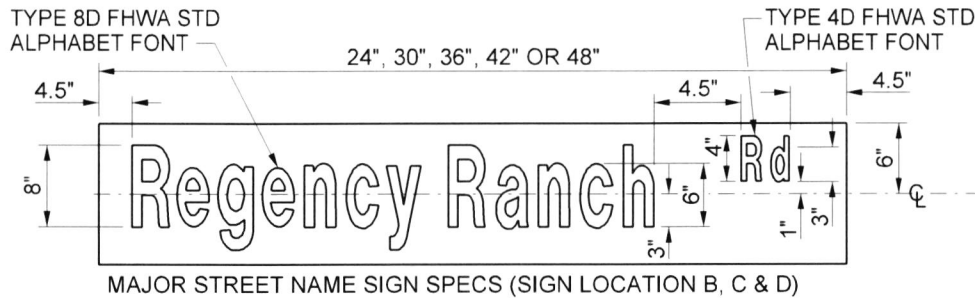
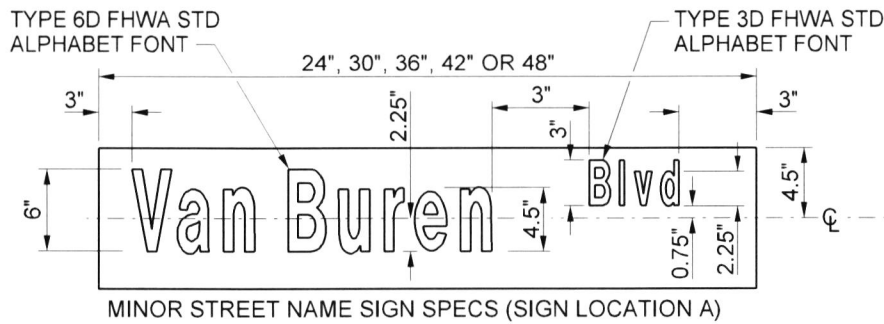

\* LETTER SIZING AND SPACING SHALL MEET FHWA SPACING GUIDELINES. MINOR VARIATIONS AS APPROVED BY ENGINEER.

**NOTES:**

- (A) SIGN PLATES (5052-H38 ALUMINUM ALLOY MATERIAL)
- (B) 2" SQ x 12" CAST ANODIZED ALUMINUM POST CAP WITH SIX 3/8" ALLEN HEAD STAINLESS STEEL SET SCREWS TO FIT 0.125" SIGN BLANK

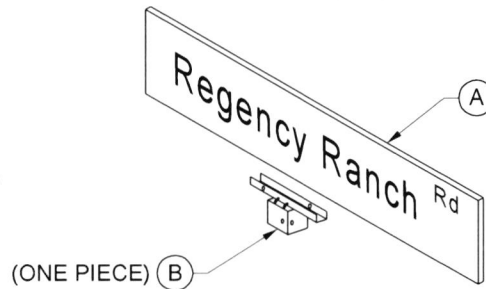

NOT TO SCALE

FOR ABBREVIATIONS SEE SHEET 2

PREPARED UNDER THE SUPERVISION OF:

*Mark Lancaster* 11/30/22  
 DIRECTOR OF TRANSPORTATION DATE  
 MARK LANCASTER, P.E.

REVISION	DESCRIPTION	MARK	DATE	APPROVED

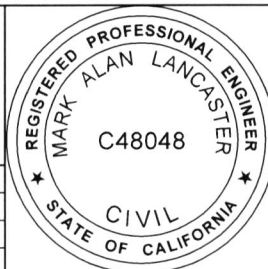

COUNTY OF RIVERSIDE

**STREET NAME SIGN  
 (CURB TO CURB WIDTH  
 GREATER THAN 60')**

**STANDARD No. 1220 (1 OF 2)**

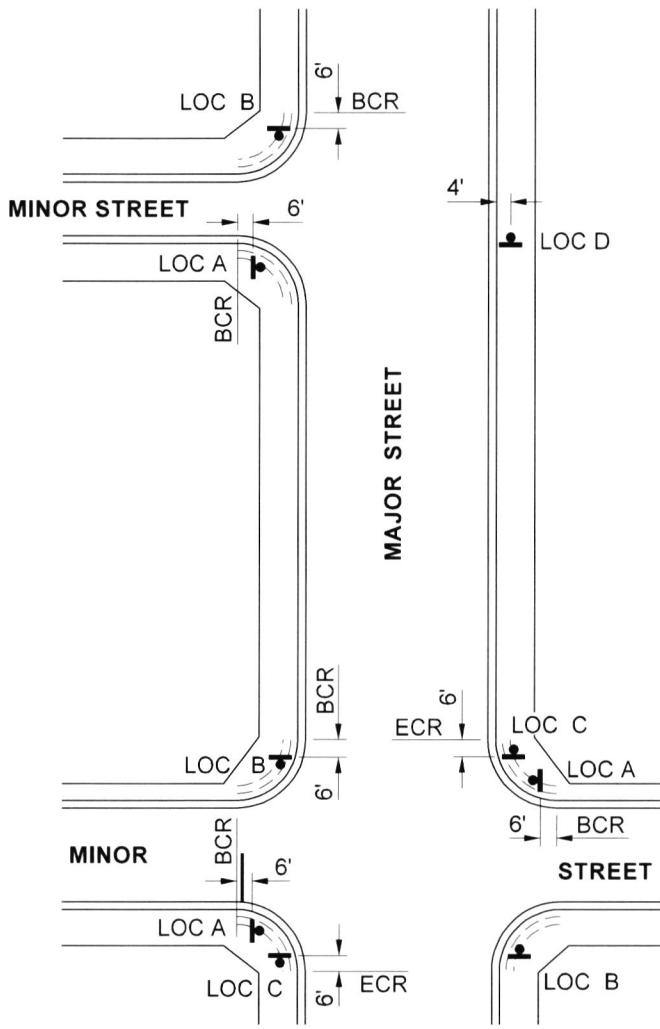

**SIGN INSTALLATION DETAILS**

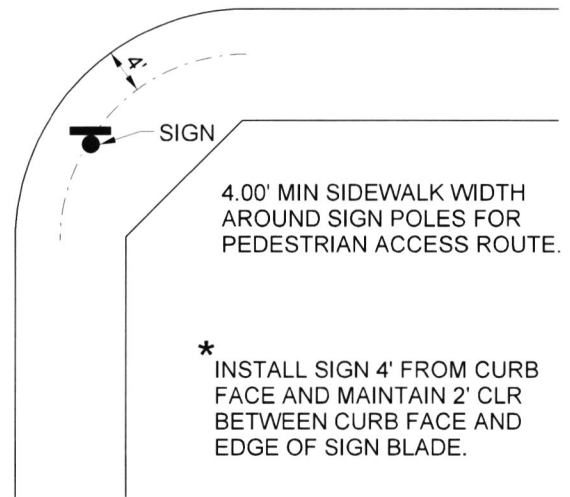

SIGNS SHALL NOT EXCEED 48". IF STREET NAME CONTAINS A SECOND WORD, SECOND WORD MAY BE ABBREVIATED AS FOLLOWS:

SUFFIX	ABBR
AVENUE	Ave
BOULEVARD	Blvd
CANYON	Cyn
CENTER	Ctr
CIRCLE	Cir
COURT	Ct
DRIVE	Dr
LANE	Ln
LOOP	Lp
PARKWAY	Pkwy
PLACE	Pl
RANCH	Rch
ROAD	Rd
SCHOOL	Sch
SPRING	Spr
STREET	St
TERRACE	Ter
TRAIL	Tr
WAY	Way

**SIGN INSTALLATION LOCATIONS**

- A. 9" BLADE, WITH MAJOR STREET NAME, PERPENDICULAR TO MINOR STREET.
- B. 12" BLADE, WITH MINOR STREET NAME, PERPENDICULAR TO MAJOR STREET.
- C. 12" BLADE, WITH MINOR STREET NAME, PERPENDICULAR TO MAJOR STREET.  
 \*(ONLY INSTALL SIGN LOC C IF SIGN LOC B DOES NOT PROVIDE GOOD SIGN VISIBILITY)

\* FINAL SIGN LOCATION TO BE DETERMINED BY ENGINEER.

NOT TO SCALE

PREPARED UNDER THE SUPERVISION OF:

*Mark Lancaster* 11/30/22  
 DIRECTOR OF TRANSPORTATION DATE  
 MARK LANCASTER, P.E.

REVISION	DESCRIPTION	MARK	DATE	APPROVED



COUNTY OF RIVERSIDE

**STREET NAME SIGN  
 (CURB TO CURB WIDTH  
 GREATER THAN 60')**

STANDARD No. 1220 (2 OF 2)

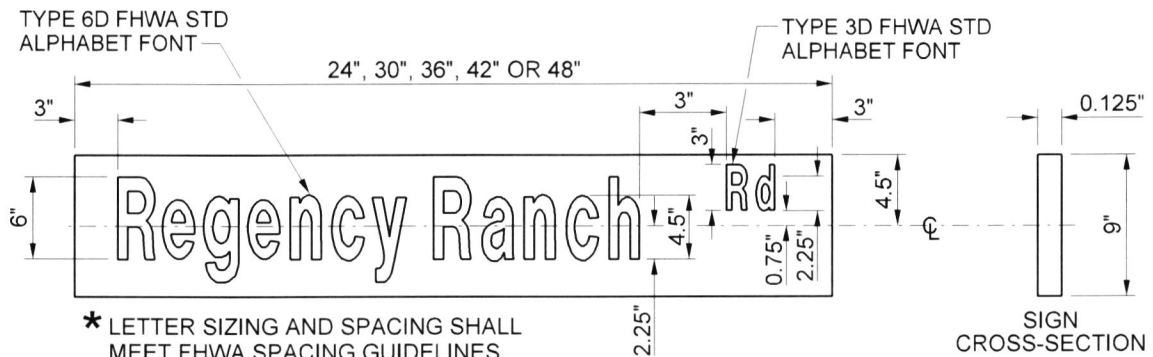
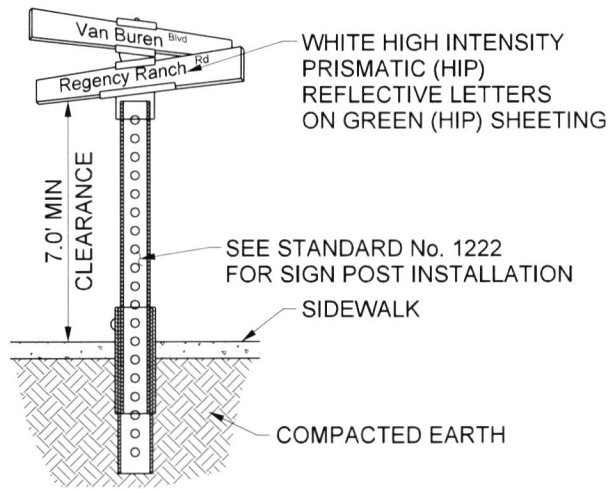

\* LETTER SIZING AND SPACING SHALL MEET FHWA SPACING GUIDELINES. MINOR VARIATIONS AS APPROVED BY ENGINEER.

**NOTES:**

- (A) SIGN PLATES (5052-H38 ALUMINUM ALLOY MATERIAL)
- (B) 2" SQ x 12" CAST ANODIZED ALUMINUM POST CAP WITH SIX 3/8" ALLEN HEAD STAINLESS STEEL SET SCREWS TO FIT 0.125" SIGN BLANK
- (C) CENTER CROSS SADDLE SHALL BE 12" ONE-PIECE CAST ANODIZED ALUMINUM WITH FOUR 3/8" STAINLESS STEEL ALLEN HEAD SET SCREWS TO FIT 0.125" SIGN BLANK

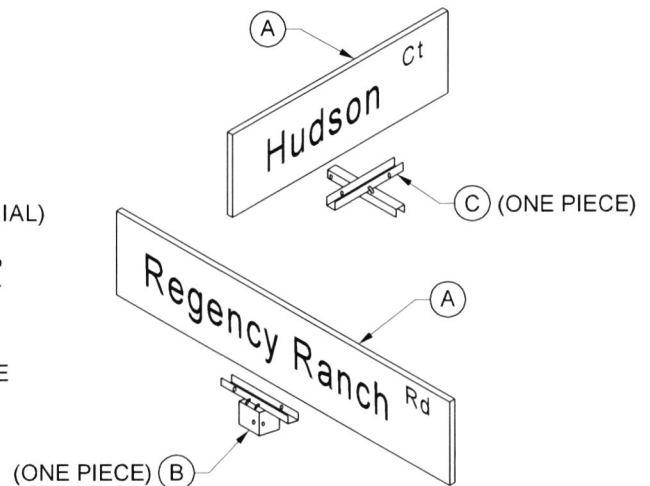

NOT TO SCALE

FOR ABBREVIATIONS SEE SHEET 2

PREPARED UNDER THE SUPERVISION OF:

*Mark Lancaster* 11/30/22  
 DIRECTOR OF TRANSPORTATION DATE  
 MARK LANCASTER, P.E.

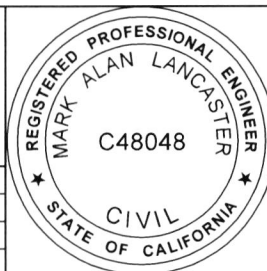

COUNTY OF RIVERSIDE

**STREET NAME SIGN  
 (CURB TO CURB WIDTH LESS  
 THAN OR EQUAL TO 60')**

STANDARD No. 1221 (1 OF 2)

REVISION	DESCRIPTION	MARK	DATE	APPROVED



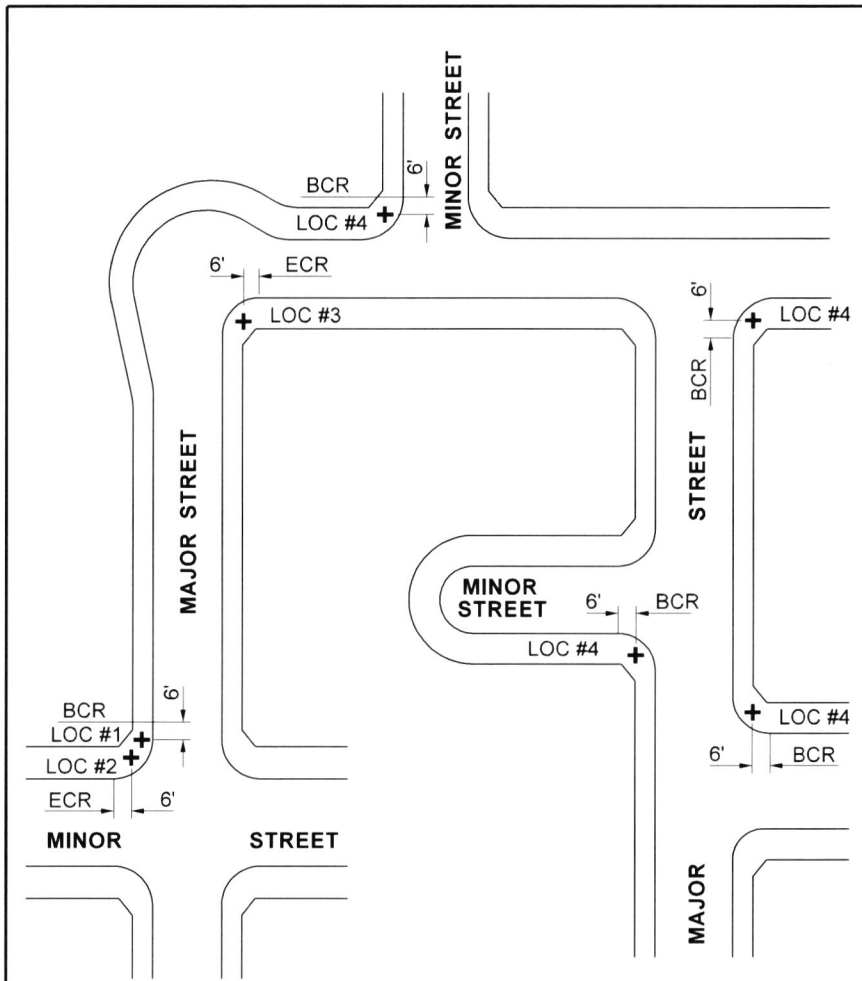

**SIGN INSTALLATION LOCATIONS**

SIGN LOC No. 1 - FOR RESIDENTIAL STREETS WITHIN A TRACT  
 SIGN LOC No. 2 - ALL OTHER STREETS THAT ARE NON-RESIDENTIAL STREETS WITHIN A TRACT FOR LOCATION THAT IS INSIDE KNUCKLES FOR T-INTERSECTION

\* FINAL SIGN LOCATION TO BE DETERMINED BY COUNTY ENGINEER

**NOTE:**  
 ONE COMPLETE NAME SIGN UNIT IS REQUIRED AT EACH INTERSECTION WHEN PAVED WIDTHS OR CURBED WIDTHS OF ALL INTERSECTING STREETS ARE 60 FEET OR LESS. AT INTERSECTIONS WITH ONE OR MORE STREETS WITH AN ULTIMATE PAVED WIDTH OR CURBED WIDTH GREATER THAN 60 FEET, USE STANDARD NO. 1220.

**SIGN INSTALLATION DETAILS**

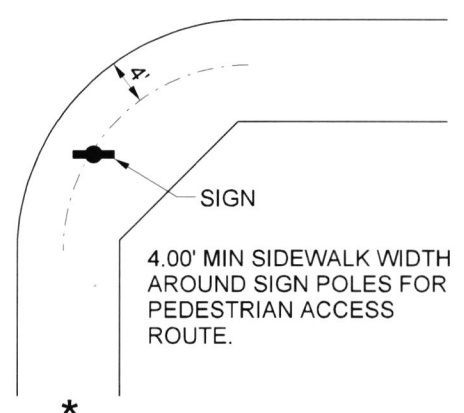

SIGNS SHALL NOT EXCEED 48". IF STREET NAME CONTAINS A SECOND WORD, SECOND WORD MAY BE ABBREVIATED AS FOLLOWS:

SUFFIX	ABBR
AVENUE	Ave
BOULEVARD	Blvd
CANYON	Cyn
CENTER	Ctr
CIRCLE	Cir
COURT	Ct
DRIVE	Dr
LANE	Ln
LOOP	Lp
PARKWAY	Pkwy
PLACE	Pl
RANCH	Rch
ROAD	Rd
SCHOOL	Sch
SPRING	Spr
STREET	St
TERRACE	Ter
TRAIL	Tr
WAY	Way

NOT TO SCALE

PREPARED UNDER THE SUPERVISION OF:

*Mark Lancaster*

11/30/22  
DATE

DIRECTOR OF TRANSPORTATION  
 MARK LANCASTER, P.E.



COUNTY OF RIVERSIDE

**STREET NAME SIGN  
 (CURB TO CURB WIDTH LESS THAN OR EQUAL TO 60')**

**STANDARD No. 1221 (2 OF 2)**

REVISION	DESCRIPTION	MARK	DATE	APPROVED

RIVET LOCATIONS  
SEE NOTE 6 ON  
SHEET 2 OF 2

DIRECTION OF  
TRAFFIC FLOW

STREET SIDE  
OF POST

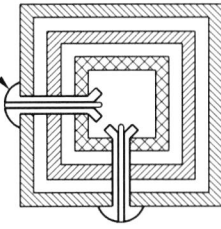

**SECTION "A-A"**

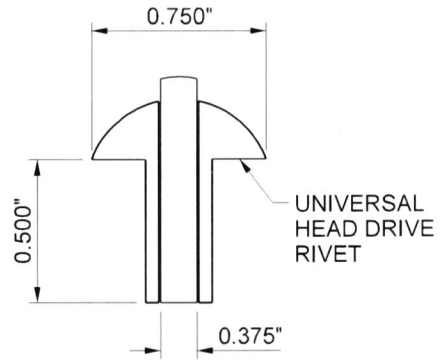

**RIVET DETAIL**

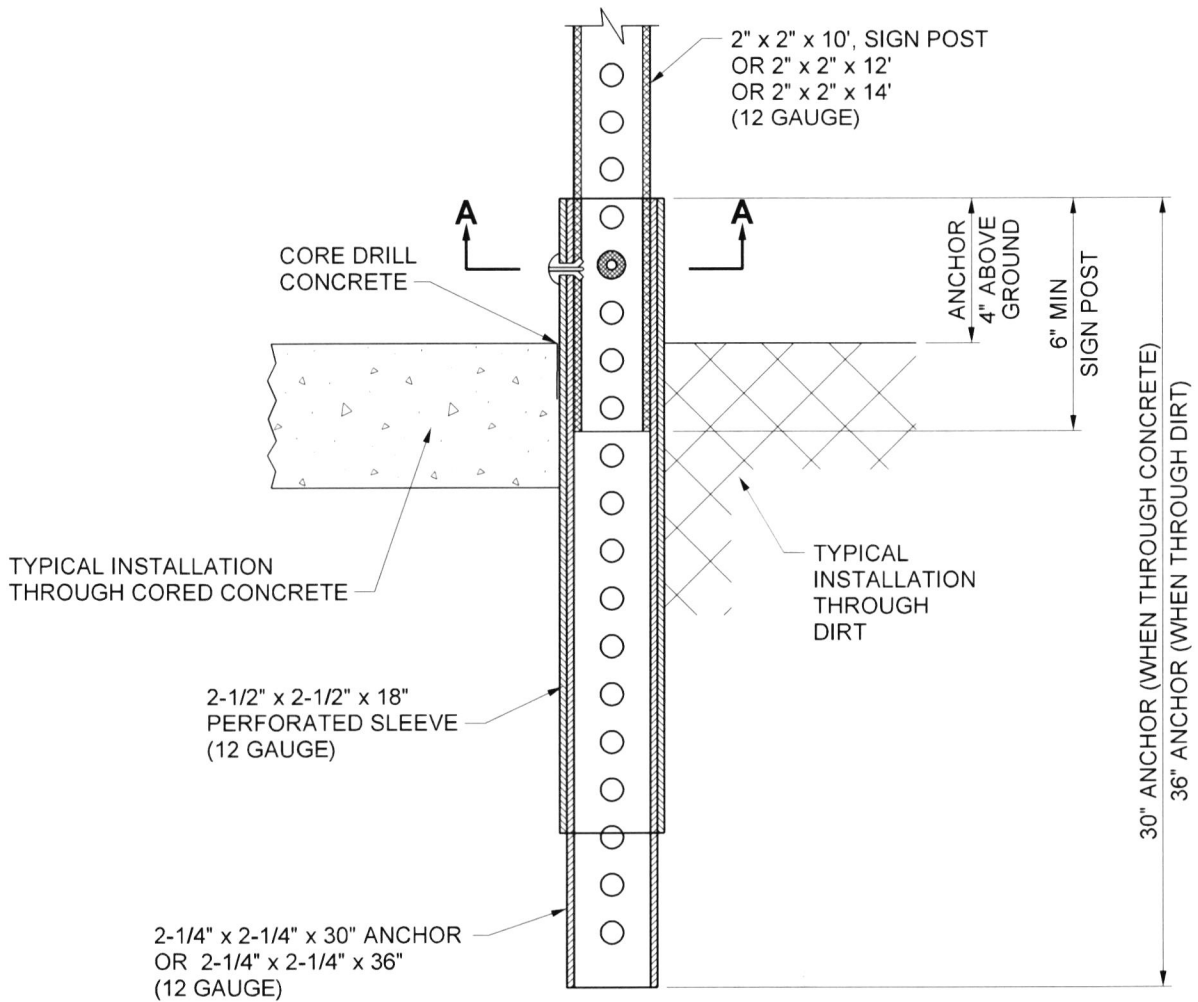

NOT TO SCALE

PREPARED UNDER THE SUPERVISION OF:

*Mark Lancaster*

11/30/22  
DATE

DIRECTOR OF TRANSPORTATION  
MARK LANCASTER, P.E.



COUNTY OF RIVERSIDE

**SIGN POST  
INSTALLATION**

**STANDARD No. 1222 (1 OF 2)**

REVISION	DESCRIPTION	MARK	DATE	APPROVED

**NOTES:**

1. SQUARE PERFORATED STEEL TUBE POST WITH TWO PIECE ANCHOR AND SLEEVE, "TELESPAR", SHALL BE USED FOR ALL TRAFFIC CONTROL AND INFORMATIONAL SIGNS WITHIN ROAD RIGHT OF WAY.
2. THE NUMBER OF POSTS REQUIRED FOR SIGN INSTALLATION SHALL BE DETERMINED BY THE AREA OF THE SIGN OR COMBINATION OF SIGNS TO BE INSTALLED. A SINGLE POST SHALL BE USED WHERE BOTH THE LENGTH AND WIDTH ARE 48" OR LESS. DOUBLE POSTS SHALL BE USED WHERE EITHER THE LENGTH OR WIDTH EXCEEDS 48".
3. THE 2 PIECE ANCHOR AND SLEEVE ASSEMBLY SHALL CONSIST OF A 2 1/4" SQUARE BY 30" (THROUGH SIDEWALK) OR 36" (THROUGH SOIL) ANCHOR WITH A 2 1/2" SQUARE BY 18" SLEEVE. ALL SLEEVES AND ANCHORS SHALL BE 12 GAUGE.
4. THE ANCHOR AND SLEEVE ASSEMBLIES SHALL BE DRIVEN SIMULTANEOUSLY UNTIL ONLY 4" REMAINS ABOVE GROUND LEVEL.
5. ALL DIRT SHALL BE REMOVED FROM THE INSIDE TOP 6" MINIMUM OF THE ANCHOR ASSEMBLY TO ALLOW FOR THE INSTALLATION OF THE SIGN POST.
6. INSTALL 2" SQUARE SIGN POST MINIMUM 6" INTO THE ANCHOR ASSEMBLY AND SECURE IN PLACE WITH TWO 3/8" DRIVE RIVETS AS SHOWN. THE RIVETS SHALL BE INSTALLED ON THE SIDE FACING TRAFFIC FLOW AND THE SIDE OF APPROACHING TRAFFIC AS SHOWN IN ORDER TO ACHIEVE THE MAXIMUM BREAK-AWAY EFFECT.
7. INSTALLATION ACCORDING TO THESE REQUIREMENTS IS ESSENTIAL TO MAINTAIN BREAKAWAY CHARACTERISTICS OF THE POST SYSTEM.
8. SEE STANDARD No's. 1220 AND 1221 FOR PLACEMENT OF SIGN POST.
9. ALL ANCHOR ASSEMBLIES SHALL BE CORE DRILLED THROUGH CONCRETE AND ASPHALT.
10. ALL SIGNS ATTACHED TO PERFORATED POSTS SHALL HAVE ZINC COATED OR STAINLESS STEEL WASHERS BEHIND THE RIVET THAT ARE LARGER THAN THE HEAD OF THE RIVET.
11. ALL REGULATORY, WARNING AND GUIDE SIGNS INSTALLED SHALL BE 0.080 INCHES IN THICKNESS.
12. ALL SIGNS 36" OR LARGER SHALL BE INSTALLED WITH BACK BRACES SPECIFICALLY DESIGNED FOR 2" SQUARE PERFORATED POSTS. (2" RISE)
13. IN SOME INSTANCES CONCRETE FOUNDATION MAY BE REQUIRED TO ENSURE PROPER STABILITY, THIS OPTION IS TO BE USED AT THE DISCRETION OF THE COUNTY ENGINEER OR DESIGNEE.

NOT TO SCALE

PREPARED UNDER THE SUPERVISION OF:

*Mark Lancaster* 11/30/22  
 DIRECTOR OF TRANSPORTATION DATE  
 MARK LANCASTER, P.E.

REVISION	DESCRIPTION	MARK	DATE	APPROVED



COUNTY OF RIVERSIDE

**SIGN POST  
 INSTALLATION**

**STANDARD No. 1222 (2 OF 2)**

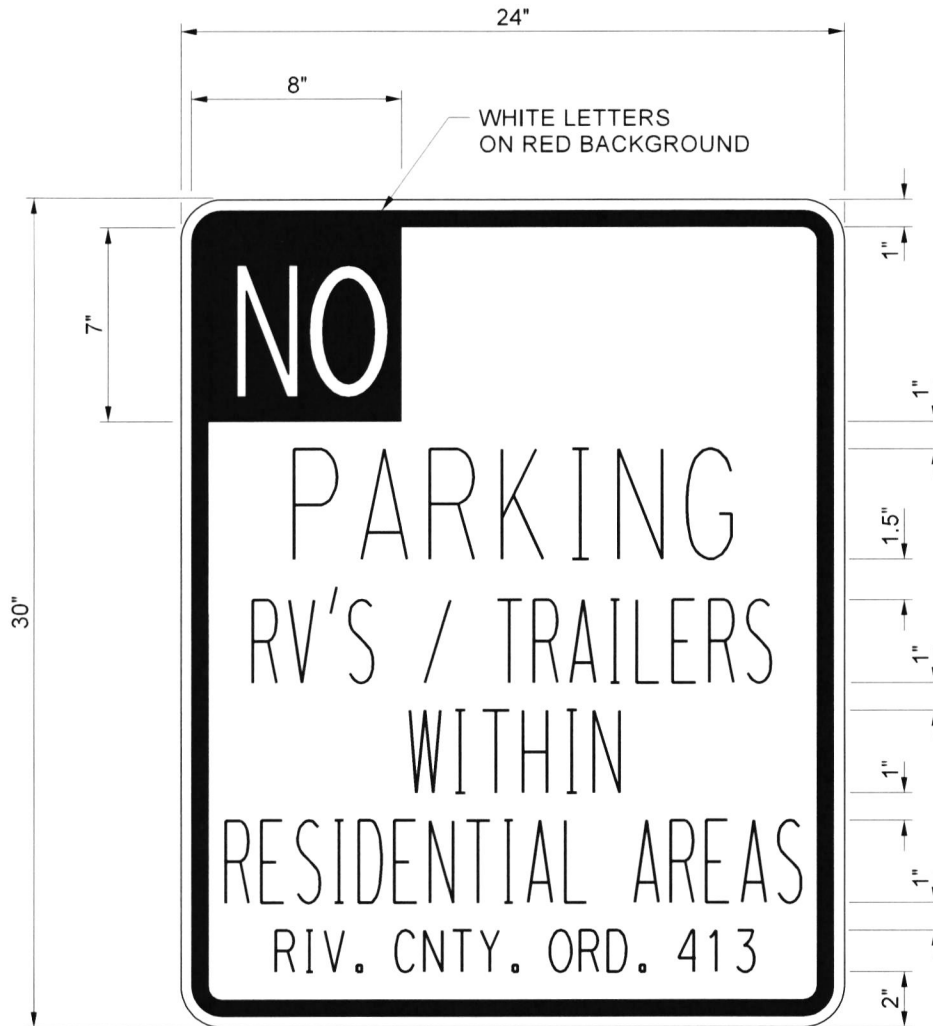

RED LETTERS ON WHITE BACKGROUND  
WITH RED BORDER

SIZE: 24" x 30"  
 C.R.: 1-1/2"  
 MARGIN: 3/8"  
 BORDER WIDTH: 5/8"  
 SINGLE FACE  
 SCREEN  
 2 HOLES, 3/8" DIA STD  
 SHEETING: SEG  
 SUBSTRATE: 0.063" ALUM  
 SCREEN ID & ANTI INK

LINE	SIZE	SERIES	COLOR	FONT	UC	LC
1	5"	B	WHT	FHWA	X	
2	4"	C	RED	FHWA	X	
3-5	3"	B	RED	FHWA	X	
6	1.5"	C	RED	FHWA	X	

NOT TO SCALE

PREPARED UNDER THE SUPERVISION OF:

  
 11/30/22  
 DIRECTOR OF TRANSPORTATION DATE  
 MARK LANCASTER, P.E.



COUNTY OF RIVERSIDE

**NO PARKING SIGN  
RV'S / TRAILERS**

STANDARD No. 1223

REVISION DESCRIPTION	MARK	DATE	APPROVED

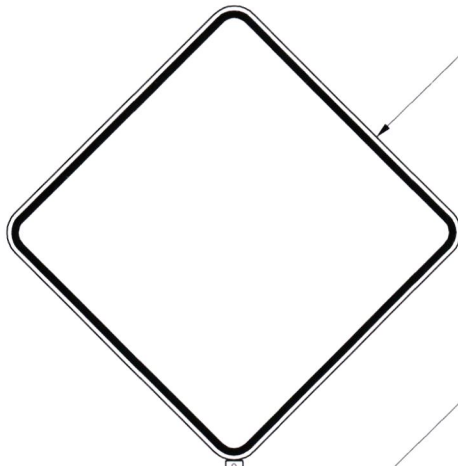

W2 SERIES OR W3 SERIES SIGN;  
36" X 36" OR SIZE AS SHOWN ON PLAN



G7-2(CA), ADVANCE STREET NAME SIGN  
8" UC / 6" LC SERIES E(M) FONTS, VAR X 24"

24"

Main St

ABBREVIATE STREET SUFFIX

VAR

14', 2"-SQUARE  
PERFORATED STEEL POST

INSTALL A SECOND 2"-SQUARE  
PERFORATED STEEL POST WHEN  
THE ADVANCE STREET NAME  
SIGN IS 60" OR WIDER, OR AS  
DIRECTED BY THE ENGINEER

PERFORATED STEEL  
POST ANCHOR PER  
COUNTY STANDARD 1222

NOT TO SCALE

PREPARED UNDER THE SUPERVISION OF:

*Mark Lancaster*  
DIRECTOR OF TRANSPORTATION  
MARK LANCASTER, P.E.

11/30/22  
DATE



COUNTY OF RIVERSIDE

**ADVANCE  
STREET NAME SIGN**

**STANDARD No. 1225**

REVISION DESCRIPTION	MARK	DATE	APPROVED

# COUNTY STANDARD SPECIFICATIONS

## TABLE OF CONTENTS

<u>SECTION</u>	<u>TITLE</u>	<u>PAGE</u>
1.	DEFINITIONS .....	1
2.	INSPECTION AND TESTING .....	2
3.	MATERIALS .....	3
4.	SCOPE OF THE WORK .....	4
5.	OBSTRUCTIONS.....	5
6.	PUBLIC SAFETY.....	5
7.	CLEARING AND GRUBBING.....	7
8.	EARTHWORK .....	7
9.	FINISHING ROADWAY .....	9
10.	BASE MATERIALS .....	9
11.	ASPHALT CONCRETE .....	11
12.	FOG SEALS AND CHIP SEALS.....	15
13.	SLURRY SEALS.....	15
14.	CONCRETE STRUCTURES .....	16
15.	CULVERT PIPE .....	17
16.	CONCRETE CURB AND GUTTER AND SIDEWALK .....	18
17.	SEWERS.....	20
18.	WATER PIPELINES .....	22
19.	UNDERGROUND UTILITY INSTALLATION .....	24
20.	STREET NAME SIGNS.....	24
21.	LAND SURVEY MONUMENTS .....	25
22.	STREET LIGHTING .....	27
23.	TRAFFIC SIGNAL AND HIGHWAY LIGHTING SYSTEM .....	28
24.	ROADWAY LANDSCAPING .....	34

The publications referred to herein are as follows:

- Standard Specifications of the California Department of Transportation, latest issue
- “Greenbook”, Standard Specifications for Public Works Construction, latest issue
- American Society for Testing Materials (ASTM), Standards and subsequent revisions
- American Association of State Highway and Transportation Officials (AASHTO), Parts I and II, latest edition
- American Water Works Association (AWWA), latest edition
- American National Standard Practice for Roadway Lighting, American National Standards Institute (ANSI)
- Department of Health Services’ publication “Criteria for the Separation of Water Mains and Sanitary Sewers, latest edition
- California Waterworks Standards, California Administrative Code
- City of Los Angeles Department of Transportation Special Provisions and Standard Drawings for the Installation and Modification of Traffic Signals “Red Book”

## 1. DEFINITIONS

- 1.01 Director of Transportation:** Shall mean the Director of Transportation of the County of Riverside, California, and any duly appointed deputies, inspectors or agents, as referred to herein.
- 1.02 County Standard Specifications:** Shall mean this document as approved by the County of Riverside Board of Supervisors by County Ordinance.
- 1.03 Caltrans Standard Specifications:** As herein referred to shall mean the Standard Specifications of the State of California, Department of Transportation, latest issue published on the Caltrans Website.
- 1.04 Caltrans Standard Plans:** As herein referred to shall mean the Standard Plans of the State of California, Department of Transportation, latest issue published on the Caltrans Website.
- 1.05 Contractor:** As herein referred to shall mean the agency or individual engaged in doing the work, and furnishing the materials herein discussed. Said Contractor shall represent the Developer insofar as the execution of the work shall be concerned, and it will be assumed that he has been so authorized by the Developer.
- 1.06 Agreement:** As herein referred to shall mean the formal Subdivision Improvement Agreements entered into with the Board of Supervisors of the County of Riverside by the Subdivider, as completed and executed by both parties. Said Agreements to set forth all requirements for improvement of the subject Subdivision, including roads, water supply systems, drainage structures, sewers, monuments or other work as set forth therein.
- 1.07 Plans:** The plans, profiles, detail sheets or other drawings or instructions as prepared by a Registered Civil Engineer in the State of California on behalf of the Developer to delineate the nature and scope of the improvement work to be done on the proposed Project. Said Plans are to be signed by the Director of Transportation as to substantial compliance with the County Road Standards and County Standard Specifications. Full responsibility for the design shown on the Plans rests with the Developer's Engineer that signed and stamped the Plans.
- 1.08 Project Specifications:** The approved project-specific specifications comprised of Caltrans Standard Specifications, County Standard Specifications, special provisions, or a combination thereof.
- 1.09 County Road Standards:** Standard drawings as prepared by the Director of Transportation and adopted by Ordinance, showing the nature of the various items of improvement work to be done and/or made a part of the Agreement.
- 1.10 Engineer:** An authorized representative of the Director of Transportation acting within the scope of his designated authority in the detailed inspection of the work.
- 1.11 Developer's Engineer:** A Registered Civil Engineer in the State of California responsible for the Plans and Project Specifications who is authorized to represent the Developer.
- 1.12 Subdivider:** Any person, firm, corporation, partnership or association who caused land to be divided into a Subdivision for himself or for others and has executed an Agreement with the County.



- 1.13 Developer:** Any person, firm, corporation, partnership or association who intends to cause improvements to be constructed within on real property and/or the public road right-of-way, including but not limited to Subdividers.
- 1.14 Acceptance:** Completion of all work in accordance with approved Plans and Project Specifications; in conformance with County of Riverside Ordinance 461, Road Improvement Standards and Specifications; and release of Securities by the Director of Transportation.
- 1.15 Laboratory:** The established Laboratory of the County of Riverside Transportation Department or other laboratories approved by the Engineer to test materials and work involved in the Agreement.
- 1.16 Terms and Definitions:** In lieu of the following terms and definitions as used in Section 1 of the Caltrans Standard Specifications, the intent and meaning shall be interpreted as follows:
- A. DEPARTMENT OF TRANSPORTATION. Shall mean the Board of Supervisors of the County of Riverside and Transportation Department, County of Riverside.
  - B. STATE or STATE OF CALIFORNIA. Shall mean the County of Riverside.

## **2. INSPECTION AND TESTING**

- 2.01 Conformity with Agreement Documents and Allowable Deviations:** Work and materials shall conform to the lines, grades, cross sections, dimensions and material requirements including tolerances, shown on the Plans or indicated in the Project Specifications. Although measurement, sampling and testing may be considered evidence as to such conformity, the Engineer shall be the sole judge as to whether the work or materials deviate from the Plans and Project Specifications, and his decision as to any allowable deviations therefrom shall be final.
- 2.02 Lines and Grades:** Such stakes or marks will be set by the Developer as the Engineer determines to be necessary to establish the lines and grades required for the completion of the work specified in Plans, County Road Standards, and Project Specifications.
- 2.03 Advance Notice:** At least forty-eight (48) hours advance notice shall be given the Director of Transportation and/or their appointed agents when requesting inspection and no paving or concrete operations will be permitted except in the presence of an inspector.
- 2.04 Inspection:** The Contractor or Developer shall at all times provide safe access for inspection of the work by the Director of Transportation and/or their appointed agents; and to any shops, plants, or areas wherein materials or portions of the work are in process.
- 2.05 Materials Testing:** Unless otherwise permitted in the Agreement, all materials tests shall be performed in accordance with the current published method as specified and used by the following agencies:
- A. American Society for Testing and Materials.
  - B. American Association of State Highway and Transportation Officials.
  - C. Published Federal Specifications (Airports, etc.) (If applicable).

- D. Test Methods as developed by Materials and Research Department - California Department of Transportation, Sacramento, California.
  - E. Should the Developer be authorized to use a private Laboratory for control of the work, and in the event that said Laboratory desires to perform the materials testing by methods not specified in County Standard Specifications, such testing methods will be submitted to the Engineer for approval together with all required data necessary to substantiate the validity of the testing results obtained by using such methods. Following a review of this proposal, the Engineer may indicate his approval of the use of such non-standard testing methods on the project.
- 2.06 Samples:** In general, all samples for testing will be taken by the Director of Transportation and/or their appointed agents from material at, or delivered to the site of the work, and such material should be available in ample time before intended use to allow for such testing. In the event that control testing for the work is performed by a private Laboratory, the Director of Transportation reserves the right to stipulate the number and location of those control tests which will relate to ultimate Acceptance of the work by the Transportation Department.
- 2.07 Removal of Rejected and Unauthorized Work:** All work which has been rejected shall be remedied or removed and replaced in an acceptable manner. Any work done beyond the lines and grades shown on the Plans or established by the Engineer, or any work done without written authority will be considered as unauthorized work. Upon order of the Engineer, work shall be remedied, removed, or replaced at no expense to the Transportation Department.
- 2.08 Equipment:** The Contractor shall provide adequate and suitable equipment to meet the above requirements, and when ordered by the Engineer shall remove unsuitable equipment from the work.
- 2.09 Final Inspection:** When the work has been completed, the Engineer will make the final inspection.

### **3. MATERIALS**

- 3.01 Quality of Materials:** In general, materials shall be new, and of a quality equal to that specified. Any material equal to that specified, in the opinion of the Director of Transportation will be approved, provided a proper request for substitution is submitted containing sufficient data or information on the article or material to permit investigation and decision. Unless such a request is made, no substitutions will be permitted. Should it be proposed to include any materials in the work not covered within County Standard Specifications, said material will, in general, be required to conform to all details of its fabrication, composition and manufacture to the applicable designation specified for the material or article in the current publications of the American Society for Testing Materials (ASTM).
- 3.02 Specified Material:** Certain materials shall be of the grades or types specified by the Director of Transportation and said materials will be so specified in the formal Agreement with the Developer or will be shown on the approved Plans of the work. Unless otherwise provided in the Agreement, all materials will be furnished by the Contractor.

**3.03 Certificate of Compliance:** The Engineer may permit the use of certain materials or assemblies prior to sampling and testing if accompanied by a Certificate of Compliance stating that the materials involved comply in all respects with the requirements of the County Standard Specifications. The certificate shall be signed by the manufacturer of the material or the manufacturer of assembled materials. A Certificate of Compliance must be furnished with each lot of material delivered to the work and the lot so certified must be clearly identified in the certificate.

All materials used on the basis of a Certificate of Compliance may be sampled and tested at any time. The fact that material is used on the basis of a Certificate of Compliance shall not relieve the Contractor of responsibility for incorporating material in the work which conforms to the requirements of the Plans and Project Specifications and any such material not conforming to such requirements will be subject to rejection whether in place or not.

The County reserves the right to refuse to permit the use of material on the basis of a Certificate of Compliance.

**3.04 Local Material:** Local material is defined as rock, sand, gravel, earth, or other mineral material obtained or produced from sources in the vicinity of the work specifically for use on the project. Local material must not be a material obtained from established commercial sources.

When requested by the Contractor or Developer in writing, the County will test materials from any local source which has not been previously tested. If the material passes the County administered tests, it is deemed satisfactory to be used in the work. The County will charge for administering the tests.

**3.05 Disposal of Excess Excavation or Materials:** Excess earth excavation or other materials resulting from construction operations shall be disposed of by the Contractor outside of the right-of-way. Material becomes Contractor's responsibility and shall be disposed at an established disposal facility or private property with valid grading/stockpiling permit. County shall have release of liability from disposal.

**3.06 Specific Brand or Trade Name and Substitution:** The Contractor or Developer may request in writing to use a product that is equal to or better than the specified brand or trade name. The request shall include substantiating data that proves the substitution causes no delay and is of equal or better quality and suitability.

#### **4. SCOPE OF THE WORK**

**4.01 General:** The scope of the work shall be set forth in the Agreement with the Developer, as shown on the Plans, County Road Standards, and as specified in the Project Specifications, or as directed by the Director of Transportation.

**4.02 Alterations in the Work:** Minor changes in the work due to unforeseen local conditions shall not be made without prior approval of the Director of Transportation. Major alterations in design or standard of work will only be permitted following execution of an amended Agreement and any work performed prior to the completion of such an amended Agreement will be performed at the owner's risk.

## **5. OBSTRUCTIONS**

- 5.01 Utility Facilities:** Any relocation of existing power, telephone poles, sewers, waterlines, gas lines, or other utility installations necessary to clear the limits of the proposed work shall be the responsibility of and paid for by the Developer, and they shall make all necessary arrangements with the owners thereof.
- 5.02 Existing Facilities:** Revisions or relocations of existing Transportation Department installations shall be shown on the Plans. In addition, the Contractor will be required to cooperate with Transportation Department personnel on the work as may be necessary to maintain proper public service. The Contractor shall protect any existing signs, culverts or other highway facilities during their operations and will be liable for any damage to same.
- 5.03 Trees:** Tree removal as shown on the Plans or as directed by the Engineer shall be the responsibility of the Developer and shall be removed to a depth of 2 feet below the finish grade, including stump grinding. An existing tree whose trunk face is located closer than eight feet from the face of the curb shall be removed unless otherwise specifically directed by the Director of Transportation. In addition, a fixed object (such as a tree) shall have clearance of eight feet minimum from the edge-of-travel-way (ETW) and four feet minimum from the edge-of-pavement (EP) in accordance with County Road Standard No. 820.

## **6. PUBLIC SAFETY**

- 6.01 Laws to be Observed:** The Contractor shall keep himself fully informed of all existing State and Federal laws and County and local ordinances and regulations which in any manner affect those engaged or employed in the work or the materials used in the work, or which in any way affect the conduct of the work. They shall at all times observe and comply with, and shall cause all of their agents and employees to observe and comply with, all such existing laws, ordinances, regulations, orders and decrees of bodies or tribunals having any jurisdiction or authority over the work; and shall protect and indemnify the County of Riverside, and all of its and their officers and agents and servants against any claim or liability arising from or based on the violation of any such law, ordinance, regulations, order or decree, whether by themselves or their employees. If any discrepancy is discovered in the Plans, County Road Standards, County Standard Specifications, or Agreement for the work in relation to any such law, ordinance, regulations, order or decree, the Contractor shall forthwith report the same to the Director of Transportation in writing.
- 6.02 Permits and Licenses:** The Contractor shall procure all permits and licenses, pay all charges and fees, and give all notices pertinent or incidental to the lawful execution of the work. The Contractor shall an encroachment permit from the Transportation Department for the various types of encroachment activities within County public right-of-way listed on County's website.  
*<http://rctlma.org/trans/Land-Development/Permits/Encroachment-Permit-Informational-Brochure-Fees>*
- 6.03 Public Convenience:** The Contractor shall so conduct their operations as to offer the least possible obstruction and inconvenience to public traffic, and they shall have under construction no greater length or amount of work than they can actively prosecute. On existing roads, unless otherwise provided in the Agreement, traffic shall be permitted to pass though the work with as

little inconvenience and delay as possible. Spillage of materials resulting from hauling operations along or across the traveled way shall be removed immediately. Spillages of hazardous materials must be promptly reported to the Engineer. Existing traffic signal and highway lighting systems shall be kept in operation for the benefit of the traveling public during progress of the work, and other forces will continue routine maintenance of existing systems. When existing traffic signal detector loops are rendered inoperable at any time during construction, the Contractor shall install and maintain temporary video detection in coordination with the Engineer and in accordance with County Standard Specifications.

Convenience of abutting owners along the road shall be provided for as far as practicable. Convenient access to driveways, houses, and buildings along the line of the work shall be maintained by the Contractor and temporary approaches to crossings or intersecting highways shall be provided and kept in good condition.

In order to expedite the passage of public traffic through or around the work, the Contractor shall install and maintain signs, lights, barricades and other facilities for the sole convenience and direction of public traffic. Such warning systems and devices shall be approved by the Director of Transportation. Also, when so directed by the Director of Transportation they shall provide and station flagmen whose sole duties shall consist of directing the movement of public traffic through or around the work.

Water or dust palliative shall be applied if ordered by the Engineer for the alleviation or prevention of dust nuisance. Applicable provisions of Section 10-5 "Dust Control", Section 14-9 "Air Quality", Section 10-6 "Watering", and Section 18 "Dust Palliative" of the Caltrans Standard Specifications; Rules no. 401, 402, 403 and 403.1 of the South Coast Air Quality Management District (AQMD); Riverside County Code, Chapter 8.52 "Fugitive Dust Reduction Program for Coachella Valley; and all other applicable Federal and State laws.

**6.04 Public Safety:** Whenever the Contractor's operations create a condition hazardous to traffic or to the public, Contractor shall furnish at their own expense such flagmen and guards as are necessary to give adequate warning to the public of any dangerous conditions to be encountered and he shall furnish, erect and maintain such fences, barricades, lights, signs and other devices as are necessary to prevent accidents, and avoid damage or injury to the public. Flagmen and guards while on duty and assigned to give warning to the public that the highway is under construction and of any dangerous conditions to be encountered as a result thereof shall be equipped in compliance with California Occupational Safety and Health Administration (Cal/OSHA) Standards. Flags, signs, lights, and other warning and safety devices shall conform to the requirements set forth in the current State of California Manual on Uniform Traffic Control Devices (CA MUTCD) and any signs furnished and erected by the Contractor shall be at his own expense.

Should the Contractor appear to be neglectful or negligent in furnishing and maintaining warning and protective measures as above provided, the Director of Transportation may direct attention to the existence of a hazard and the necessary warning and protective measure shall be furnished and installed by the Contractor at his own expense without cost to the County. Should the Director of Transportation point out the inadequacy of warning and protective measures, such action on the part of the Director of Transportation shall not relieve the Contractor from responsibility for public safety or abrogate his obligation to furnish and pay for these devices.

No material or equipment shall be stored where it will interfere with the free and safe passage of public traffic, and at the end of each day's work and at other times when construction operations are suspended for any reason, the Contractor shall remove all equipment and other obstruction from that portion of the roadway open for use by public traffic.

- 6.05 Use of Explosives:** When the use of explosives is necessary for the prosecution of the work, the Contractor shall use the utmost care not to endanger life or property. Contractor must obtain necessary local, state and/or federal permits required prior to the use of explosives.

All explosives shall be stored in accordance with the provisions of Division XI of the Health and Safety Code. Attention is called to local ordinances involving the use or storage of explosives and for excavating rock by blasting shall conform with applicable provisions of Section 19-4 of the Caltrans Standard Specifications.

- 6.06 Lane Closure:** Lane closures shall conform to the most current State of California Manual on Uniform Traffic Control Devices (CA MUTCD). Should it be necessary for the lane closure to remain in place after standard work hours, the Contractor shall provide a traffic control plan prepared and signed by a Traffic Engineer registered in the State of California. Lanes shall be opened back to Traffic after 2 weeks of no active work in the closure area. Standard work hours are from 7:00 am to 6:00 pm pursuant to Ordinance 847.

## **7. CLEARING AND GRUBBING**

- 7.01 General:** Clearing and grubbing operations shall conform with the provisions of Section 17 of the Caltrans Standard Specifications and the details shown on the Plans.

- 7.02 Concrete Removal, Structure Removal or Pavement Removal:** This construction activity shall be considered a part of the clearing operation and shall conform with the applicable provisions of Section 15-1, Section 41-11 or Section 60-2 of the Caltrans Standard Specifications. Such removed materials shall be disposed of as elsewhere provided herein or as approved by the Engineer. When portions of existing concrete or paved surfaces are to be cut back to provide for joining or widening, such surfaces shall be sawed or otherwise cut to neat lines.

## **8. EARTHWORK**

- 8.01 General:** Included under the term "Earthwork" will be all operations involved in grading roadway excavation or embankment construction required to bring the roadway section to the approved grade, and such drainage and structure excavation and backfill as may be required by the approved Plans. These operations to include the performance of all incidental work required to construct the roadway subgrade and the approaches thereto, and to maintain them in the form specified until the final Acceptance by the County.

All earthwork shall conform with the applicable provisions of Section 19 of the Caltrans Standard Specifications except as herein modified.

- 8.02** Relative compaction requirement of at least 95 percent for at least a depth of 2.5 feet below the finished grade for the width of the traveled way plus 3 feet on each side shall not be required.

This provision will not preclude the necessity of conforming to the provisions of the relative compaction requirement of Section 19-5 of the Caltrans Standard Specifications.

- 8.03 Watering:** Embankments and subgrade shall be watered or sprinkled during construction so as to obtain the specified relative compaction of the material included therein.
- 8.04 Ditches and Channels:** Drainage inlet and outlet ditches and channels shall be constructed to lines and grades shown on the approved Plans and profiles and as specified in Section 19-2 of the Caltrans Standard Specifications. Channels shall be constructed upstream and downstream of all culverts as necessary to insure proper capacity for same.
- 8.05 Structural Section Design of Roadbed:** Unless otherwise approved by the Director of Transportation, structural section design requirements for the combined thickness of asphalt concrete (AC) and aggregate base (AB) surfacing will be determined by an accepted rational system of design, employing soil testing procedures; and the necessary sampling, testing and the design of the aggregate base and asphalt concrete surface courses will be performed by the County Materials Laboratory, unless otherwise provided in the Agreement. All street structural sections are tentative. Additional soil tests will be taken after rough grading to determine the exact street structural section requirements. The structural section shall be in accordance with County Road Standards and approved by the County Materials Engineer.

The table below lists the minimum asphalt concrete thickness for each of the road types. The road type and traffic index shown are in accordance with County Road Standard No. 114.

Road Type	Traffic Index	Minimum Structural Section <sup>1,2</sup> Thickness (feet)
Access Road <sup>3</sup>	5.5	0.25' AC / 0.50' AB
Short Local Street <sup>4</sup>	5.5	0.25' AC / 0.50' AB
Exterior & Local Street <sup>4</sup>	5.5	0.25' AC / 0.50' AB
Enhanced Local Street at School or Park	6.5	0.30' AC / 0.50' AB
Collector	7.0	0.35' AC / 0.50' AB
Industrial Collector	8.0	0.40' AC / 0.50' AB
Secondary Highway	8.5	0.45' AC / 0.50' AB
Major Highway	9.0	0.45' AC / 0.50' AB
Mountain Arterial Highway	9.5	0.50' AC / 0.50' AB
Arterial Highway	9.5	0.50' AC / 0.50' AB
Urban Arterial Highway	10.0	0.55' AC / 0.50' AB
Expressway	11.0	0.60' AC / 0.50' AB

**NOTES:**

1. The minimum thickness for the Class 2 Aggregate Base is 0.50 feet.
2. The Transportation Department accepts alternate structural sections including full depth asphalt concrete or multi-layered aggregate subbase, lime or cement treated bases overlaid with Class 2 Aggregate Base. The thickness of the Class 2 Aggregate Base in these instances can be less than 0.5 feet provided the gravel equivalency of the total structural section is maintained.
3. For access roads, if the ultimate road classification is a General Plan Highway, the traffic index requirement is 7.0.

4. When the asphalt concrete section is constructed in two courses (base course and surface course), the construction of the asphalt concrete courses shall be placed as follows: (a) the bottom lift (base course) shall have a minimum thickness of 0.15 foot using 1/2-inch size aggregate or 0.20 foot using 3/4-inch size aggregate and (b) the top lift (surface course) shall be 0.15 foot using 1/2-inch size aggregate.

## **9. FINISHING ROADWAY**

- 9.01 General:** Upon completion of all construction operations, the entire street system shall be finished and cleaned in accordance with the provisions of Section 22 of the Caltrans Standard Specifications and these Special Provisions.
- 9.02 Shoulders:** Roadways shoulders shall be trimmed and shaped to conform with the requirements of the approved typical section. This will include grading on optimum slope to the property lines if so directed. Included in this portion of the work shall be additional clearing, grubbing, or removal of debris not previously completed by the Contractor.
- Concrete curbs-and-gutters, and cross-gutters shall be broomed clean and flushed with water to insure proper drainage. Any underground drainage systems or storm drain facilities shall be thoroughly flushed out to insure proper operation.
- 9.03 Appurtenances:** Street name signs, barricades and warning devices shall be completed and in place.
- 9.04 Monuments:** Unless otherwise approved by the Director of Transportation, all survey monuments located within the improved street area shall be in place and pavement cuts neatly patched.
- 9.05 Final Cleanup:** Prior to inspection and Acceptance of the completed work, all items of finish work as outline above must be completed.

## **10. BASE MATERIALS**

- 10.01 General:** Base material to be used in construction of the upper layers of the roadbed shall consist of the following material classifications for the respective Land Division Schedules as identified in County of Riverside Ordinance 460.
- A. Aggregate Base, Class 3 or Disintegrated Granite - Schedule D H & I Land Division
  - B. Aggregate Base, Class 2 - Schedule A, B, C, E, F & G Land Division
  - C. Lime Treated Base
  - D. Cement Treated Bases

NOTE: When roads are accepted for maintenance by the County, the aggregate base shall be Class 3 or higher. Disintegrated granite may be substituted for aggregate base when approved by the County Materials Engineer. When there is concrete curb and gutter, a Class 2 aggregate base shall be used.



The exact type of base material to be used on the work will be specified in the Agreement and shown on the Plans.

**10.02 Disintegrated Granite:** Disintegrated granite shall be clean and free from roots, vegetable matter and other deleterious substances, and be of such character that when wet it will compact to form a firm stable base. Disintegrated granite shall be any igneous rock, which has been weathered in place, or any sedimentary material principally derived from igneous rock. The material shall be of such sizes that the percentage composition by weight of material shall conform to the following grading at the time the material is deposited on the roadbed when determined by California Test Method (CTM) No. 202.

Sieve Size	Percentage Passing Sieve
1 inch	90 - 100
No. 4	50 - 95
No. 30	20 - 60
No. 200	3 - 15

The material shall conform to the following requirements:

Tests	CTM No.	Requirements
Resistance ("R" Value)	301	70 Min.
Sand Equivalent	217	30 Min.

**10.03 Aggregate Base, Class 3:** Aggregate Base, Class 3 shall conform to the provisions of Section 26 of the Caltrans Standard Specifications. Aggregate may include material processed from reclaimed asphalt concrete, Portland cement concrete, lean concrete base, cement treated base, or a combination of any of these materials. The amount of reclaimed material shall not exceed 50 percent of the total volume of the aggregate used.

The material shall conform to the following quality requirements:

Property	CTM No.	Requirements
Resistance (R-value)	301	60 Min.
Sand Equivalent	217	21 Min.

**10.04 Aggregate Base, Class 2:** Aggregate Base, Class 2 shall conform to the provisions of Section 26 of the Caltrans Standard Specifications and as modified herein. Section 26 shall include the following provision: Aggregate for Class 2 aggregate base shall be free from organic matter and other deleterious matter and shall be of such nature that it can be compacted readily under watering and rolling to form a firm and stable base. Aggregate may consist of broken and crushed asphalt concrete or Portland Cement Concrete and may contain crushed aggregate base (crushed rock and rock dust) or other rock materials. The material may contain no more than 3 percent brick by weight as determined by California test method 202 and as modified: Brick material retained on a No.4 sieve shall be identified visually and separated manually. Brick quantification shall be based on total weight of dry sample.

The Quality Requirements provisions contained in Section 26 for the Class 2 Aggregate Base shall be modified to read:

<b>Property</b>	<b>Compliance Requirement</b>
Resistance (R-value)	
Crushed Aggregate	80 Min.
Crushed Miscellaneous	78 Min.
Sand Equivalent	35 Min.
Durability Index	35 Min.
Percentage Wear	
100 revolutions	15 Max.
500 revolutions	52 Max.

- 10.05 Stabilized Soils:** Lime treated base shall conform to the provisions of Section 24 of the Caltrans Standard Specifications.
- 10.06 Cement Treated Base:** Cement treated base shall conform to the provisions of Section 27 of the Caltrans Standard Specifications.
- 10.07 Concrete Base:** Lean concrete or rapid strength concrete base shall conform to the provisions of Section 28 of the Caltrans Standard Specifications.

## **11. ASPHALT CONCRETE**

**11.01 General:** Asphalt concrete shall be composed of mineral aggregate and asphalt binder, mixed in a suitable central mixing plant, and placed on the roadbed in accordance with County Standard Specifications and in conformity with the lines, grades and dimensions shown on the Plans and typical cross-sections. When required by the Director of Transportation, the Developer shall provide an asphalt concrete mix design as appropriate for the designated location, prepared under the direction of the Developer's Engineer registered in the State of California competent to perform the work.

Asphalt concrete shall be placed on the prepared subgrade or base course in one or more courses to the required thicknesses, grades and cross-sections as shown on the Plans and/or specified in the Agreement. All underground utilities shall be in place prior to paving.

In advance of spreading the asphalt concrete, a prime coat of liquid asphalt or asphaltic emulsion shall be applied to the areas to be surfaced if so indicated on the Plans. Prime coat shall be applied to all roadbeds to receive surfacing, which have a gradient of ten percent or greater.

**11.02 Asphalt Concrete:** Asphalt concrete shall be hot mix asphalt (HMA) Type A, rubberized HMA, or minor HMA conforming to Section 39 of the Caltrans Standard Specifications and these Special Provisions. The grade of asphalt binder for the HMA shall be of the Performance Grade (PG)

designated below or as determined by the Engineer and shall conform to the provisions in Section 92 of the Caltrans Standard Specifications.

- A. PG 64-10 (Inland Valleys)
- B. PG 64-16 (South Mountain)
- C. PG 70-10 (Desert)

The PG designation for rubberized HMA is PG 64-16 for all regions.

The use of reclaimed asphalt pavement (RAP) in HMA production may be substituted in a quantity up to 15 percent of the aggregate blend in the base course (bottom layer) only. When proposing to use more than 15 percent RAP, the HMA mix design shall be approved by the County Materials Engineer prior to its use. RAP will not be allowed in the surface course (top layer). RAP in rubberized HMA will not be allowed unless directed. RAP will not be allowed on all repaired asphalt concrete surfaces.

A Job Mix Formula (JMF) shall be submitted for each type of HMA proposed using the County of Riverside Transportation Department Contractor Job Mix Formula Proposal form. The JMF shall be signed and stamped by a Civil Engineer registered in the State of California and shall include records of aggregate quality and mix design documentation. Records and documentation shall be dated within 12 months of the last test performed.

The HMA mix design shall comply with the Hveem mix design method using California Test 367 and laboratory procedures in combinations of aggregate gradations and asphalt binder contents to determine the optimum binder content (OBC) and HMA mixture qualities. When proposing a Superpave (SP) HMA, the SP mix design shall be approved by the County Materials Engineer prior to its use. The SP mix design method shall be used for roads with Traffic Index of 9.0 or higher or as determined by the Engineer.

Laboratories testing the mineral aggregate and HMA qualities used to prepare the mix design and JMF shall be qualified under the State of California Department of Transportation's Independent Assurance Program.

Before production of HMA, the HMA plant must have a current qualification under the State of California Department of Transportation's Materials Plant Quality Program. Laboratories testing the HMA qualities shall be qualified under the State of California Department of Transportation's Independent Assurance Program.

**11.03 Placing Asphalt Concrete:** Asphalt concrete will not be permitted to be placed upon unstable, yielding or working subgrade.

In addition to the provisions in Section 39, "Construction" and "Spreading and Compacting Equipment" of the Caltrans Standard Specifications, asphalt paving equipment shall be equipped with automatic screed controls and a sensing device(s) or ski device(s). The use of a ski device will be required for roads with traffic index of 7.5 or higher. The ski device shall be a rigid one-piece unit with a minimum length of 30 feet and the entire length shall be utilized in activating the sensor.

When placing the initial mat of asphalt concrete on existing pavement, the end of the screed nearest the centerline shall be controlled by a sensor activated by a ski device not less than 30

feet long. The end of the screed farthest from centerline shall be controlled by an automatic transverse slope device set to reproduce the cross slope designated by the Engineer, by a sensor activated by a similar ski device or as directed by the Engineer. When paving contiguously with previously placed mats, the end of the screed adjacent to the previously placed mat shall be controlled by a sensor that responds to the grade of the previously placed mat and will reproduce the grade in the new mat within a 0.12 inch tolerance. The end of the screed farthest from the previously placed mat shall be controlled in the same way it was controlled when placing the initial mat.

Should the methods and equipment used fail to produce a layer of asphalt concrete conforming to the provisions, including straightedge tolerance, under "Constructions" of Section 39-2, Construction, of the Caltrans Standard Specifications or elsewhere in these County Standard Specifications, the paving operations shall be discontinued the equipment or methods shall be modified.

Hot mix asphalt shall be spread and compacted in the number of layers of the thicknesses indicated in the following table:

<b>HMA Pavement Thickness Shown on Plans (ft)</b>	<b>No. of Layers <sup>a</sup></b>	<b>Gradation</b>
Less than 0.15	1	3/8 inch
0.15 to less than 0.20	1	1/2 inch
0.20 to less than 0.25	1 <sup>b</sup>	3/4 inch
0.25 or greater	2 or more <sup>c,d</sup>	3/4 inch or 1 inch

<sup>a</sup> Top layer shall not contain RAP in the HMA mix.

<sup>b</sup> If 1/2 inch grading is used, the HMA shall be placed in two layers.

<sup>c</sup> Bottom and all other lower layers shall contain up to 15 percent RAP in the HMA mix or as approved by the Engineer.

<sup>d</sup> One layer of 0.25 foot for the 3/4 inch may be placed as approved by the Engineer.

In addition to the straightedge provisions in Section 36-3, "Pavement Smoothness" of the Caltrans Standard Specifications, asphalt concrete pavement shall conform to the surface tolerances specified herein.

When directed by the Engineer, the uppermost layer of asphalt concrete surfacing shall be profiled in the presence of the Engineer. Profiling will not be required for the following areas of the pavement surface but shall conform to the straightedge requirements in Section 36-3, "Pavement Smoothness" of the Caltrans Standard Specifications:

- A. Roads with traffic index of 6.0 or lower.
- B. Pavement with a total thickness less than 0.24 foot.
- C. Pavement on horizontal curves with a centerline curve radius of less than 1000 feet and the pavement within the superelevation transition on those curves.
- D. Pavement placed in a single lift when required by the special provisions with a total thickness of 0.25 foot or less.
- E. Pavement with extensive grade or cross slope correction which does not receive advance leveling operations in conformance with the provisions in Section 39 under "Leveling" of the Caltrans Standard Specifications.
- F. Pavement for ramps and connectors with steep grades and high rates of superelevation, as determined by the Engineer.
- G. Shoulders and miscellaneous areas.

When using the Inertial Profiler, the profiling operation shall conform to California Test 387. The final HMA surface shall conform to the provisions of Pavement Smoothness in Section 39 of the Caltrans Standard Specifications. Pavements profiled shall conform to the following surface requirements:

- A. Surface shall have no areas of localized roughness with an International Roughness Index (IRI) greater than 160 in/mi.
- B. Surface shall comply with the Mean Roughness Index requirements as shown below for a 0.1 mile section:

<b>HMA Thickness</b>	<b>Mean Roughness Index Requirement</b>
>0.20 foot	60 in/mi or less
≤0.20 foot	75 in/mi or less

When using the California Profilograph, the profiling procedure shall conform to California Test 526, except a zero (null) blanking band shall be used for determining the Profile Index. Prior to beginning profiles, the profilograph shall be calibrated in the presence of the Engineer. Two profiles shall be obtained within each traffic lane, 3 feet from and parallel with the edges of the lane. Pavements profiled shall conform to the following Profile Index requirements:

- A. Pavement on tangent alignment and pavement on horizontal curves having a centerline curve radius of 5940 feet or more shall have a Profile Index of 0.16 foot or less for each 330 feet section profiled.
- B. Pavement on horizontal curves having a centerline curve radius of 2970 feet or more but less than 5940 feet, including the pavement within the superelevation transition of these curves, shall have a Profile Index of 0.32 foot or less for each 330 feet section profiled.
- C. Pavement within any 330 feet section, containing high point areas with deviations in excess of 0.025 foot in a length of 25 feet or less, when tested in conformance with the requirements in California Test 526, shall be corrected by the Contractor regardless of the Profile Index.

Areas of the top surface of the uppermost layer of asphalt concrete pavement that do not meet the specified surface tolerances shall be brought within tolerance by abrasive grinding. Abrasive grinding shall be performed to reduce individual deviations in excess of 0.025 foot, and to reduce the Profile Index of the pavement to be within the specified tolerance. Areas which have been subjected to abrasive grinding shall receive a seal coat. Deviations in excess of 0.025 foot which cannot be brought into specified tolerance by abrasive grinding shall be corrected by either (1) removal and replacement or (2) placing an overlay of asphalt concrete.

- 11.04 Underground Installation:** All underground facilities, including laterals, shall be in place and tested prior to paving the street section, including, but not limited to, the following: sewer, water, electric, gas, drainage, communications, cable TV, and irrigation. The Contractor shall provide written verification from the affected utilities of acceptable test results prior to proceeding with paving operations.

## **12. FOG SEALS AND CHIP SEALS**

- 12.01 General:** A fog seal shall conform to Section 37-4 of the Caltrans Standard Specifications. A chip seal shall conform to Section 37-2 of the Caltrans Standard Specifications.

- 12.02 Description:** A fog seal shall consist of an application of a diluted slow-setting or quick-setting asphaltic emulsion to an existing asphalt pavement surface. The fog seal shall be applied at a rate of 0.02 to 0.06 gallon per square yard of surfacing. The exact rate of application of the emulsion will be determined at the time of application based on the age and surface texture of the pavement.

A chip seal shall consist of an application of a polymer modified asphaltic emulsion and stone screenings applied to the asphalt pavement surface. The chip seal shall use stone screening size of 5/16 inch with a spread rate of 16 to 25 pounds per square yard. The asphaltic emulsion shall be applied at rate of 0.25 to 0.35 gallon per square yard. The exact rate of application of the emulsion and the screenings will be determined at the time of the application by the Engineer.

- 12.03 Asphaltic Emulsion:** The asphaltic emulsion shall conform to the requirements of Section 94 of the Caltrans Standard Specifications.
- 12.04 Application:** A fog seal shall be applied on pavement of less than 4 years but more than 2 years in service or after placement of the asphalt surfacing and shall be used on roads with traffic index of 6.0 or lower. Chip seal shall be applied on rural roads with low volume traffic or as directed.
- 12.05 Road/Work Acceptance:** Where applicable, a fog seal treatment shall be required for all pavement work prior to acceptance and/or issuance of a notice of completion for roads to be accepted into the County maintained road system.

## **13. SLURRY SEALS**

- 13.01 General:** A slurry seal shall conform to Section 37-3 of the Caltrans Standard Specifications.
- 13.02 Description:** A slurry seal shall consist of an application of a mixture of polymer modified asphaltic emulsion, aggregate, water, and additives to an existing asphalt pavement surface. The

slurry seal shall be applied at a rate of 8 to 10 pounds per square yard for Type I and at a rate of 12 to 15 pounds per square yard for Type II. The asphaltic emulsion for Type I shall be within 17 to 20 percent and within 14 to 18 percent for Type II. The exact percentage of the emulsion will be determined at the time of application based on an approved mix design. The polymer content shall be a minimum of 2.5 percent.

**13.03 Asphaltic Emulsion:** The asphaltic emulsion shall conform to the requirements of Section 94 of the Caltrans Standard Specifications. The polymer shall be either neoprene or butadiene and styrene copolymer.

**13.04 Application:** A slurry seal shall be applied on pavement of 4 years or more in service or after placement of the asphalt surfacing. A Type I slurry seal shall be used on roads with Traffic Index of 6.0 or lower. A Type II slurry seal shall be used on roads with Traffic Index greater than 6.0. A slurry seal shall be applied when the following conditions exist:

- A. Use of abrasive grinding on the asphalt pavement as a result of surface profiling.
- B. Excessive scarring on the asphalt pavement due to the removal of existing or conflicting traffic striping.
- C. Where multiple trenches or potholing are cut on the asphalt pavement because of a utility replacement project.
- D. Other conditions that result in significant wear or damage to the pavement surface as determined by the Engineer.

**13.05 Road/Work Acceptance:** Where applicable, a slurry seal treatment shall be required for all pavement work prior to acceptance and/or issuance of a notice of completion for roads to be accepted into the County maintained road system.

## 14. CONCRETE STRUCTURES

**14.01 Description:** Bridges, culverts, head walls, catch basins, retaining walls, and all other types of transportation structures shall be constructed to the lines and grades in accordance with the designs shown on the Plans. Each type of structure shall comply with the minimum cementitious material content shown in the table below unless shown on the Plans.

Type of Structure	Cementitious Material Content# (lb/cu yd)	County Road Standard Number
Catch Basin No. 1 Curb Inlet Combination Inlet	590	300 301
Catch Basin No. 2 Combination Inlet	590	302
Flat Outlet Drainage Structure	590	303
Dip Section	590	307
Curb Outlet Drain	590	308
Alley and Alley Apron Sections	590	500
Sewer & Manholes	590	601, 603, 604, 605, 606, 607, 610

Bus Turn Out	590	814
Slab for Backflow Prevention	505	1103
Sewer & Storm Drainage Facilities Catch Basins, Culverts, Drop Inlets, Pipe Collars, Beam Supports, Anchors, Thrust Block, Encasement	590	
Reinforced Structures Retaining walls, footings	590	
Minor Structures not specified	505	

- 14.02 Concrete Structures:** Except for minor structures, concrete structures shall conform to the provisions in Section 51 of the Caltrans Standard Specifications and these Special Provisions.
- 14.03 Reinforcement:** Bar reinforcing steel and mesh reinforcement used in construction shall conform to the provisions in Section 52 of the Caltrans Standard Specifications.
- 14.04 Air-Blown Mortar:** Air-blown mortar shall conform to the provisions in Section 53 of the Caltrans Standard Specifications.
- 14.05 Precast Concrete Structures:** Precast concrete catch basins and drop inlets shall conform to the provisions in Section 70 of the Caltrans Standard Specifications.

## 15. CULVERT PIPE

- 15.01 General:** The type, strength, classification, or gauge of drainage pipe to be furnished and installed will be designated on the Plans. Details of the materials and work will conform with Caltrans Standard Specifications and Caltrans Highway Design Manual Guidelines, latest editions.
- 15.02 Design Service Life:** All drainage facility material types shall have a minimum design service life of 50 years. All metal pipes shall be subject to the requirements of the Caltrans Chart for 50 years Maintenance Free Service Life as contained in the Caltrans Design Manual. Soil tests using Caltrans Test Method 643 shall be provided to determine the pH and resistivity levels of the native soils and imported backfill materials.
- 15.03 Alternate Materials:** When two or more materials meet the service life, the structural requirements, and the hydraulic requirements; the Plans and Project Specifications may provide for alternative pipe materials for optional selection by the Contractor. Allowable pipe materials are:
- A. Aluminum Spiral Rib
  - B. Cast-in-Place Concrete
  - C. Corrugated Aluminum
  - D. Corrugated Steel
  - E. Reinforced Concrete
  - F. Structural Aluminum Plate



G. Structural Steel Plate

H. Steel Spiral Rib

The use of aluminum pipe shall be limited to the acceptable levels for pH, resistivity, and flow velocities. The pH level of soil, backfill, and effluent shall range within 5.5 and 8.5, inclusive. The minimum resistivity of the soil, backfill, and effluent shall be 1500 ohm-cm. Flow velocities shall not exceed 20 feet per second.

When alterations or extensions of existing systems are required, the pipe material type may be selected to match the type used in the existing system.

Each pipe material type selected as an alternative must have the appropriate protection from deterioration from corrosion, abrasion, or both. Corrosion may result from active elements in the soil, the water, and the atmosphere. Abrasion depends upon the frequency, duration, and the velocity of flow, and the character and amount of bedload.

**15.04 Protective Coatings and Linings:** Protective coatings for corrugated steel pipe shall conform to Section 66 of the Caltrans Standard Specifications.

Plastic (asphalt mastic or polymeric) coatings are acceptable coatings for non-abrasive flow conditions on the inside of the pipe.

Paved invert lining shall be applied on all steel storm drain facilities. Invert lining may be required for metal pipes subject to excessive wear from abrasive flows. All lining material shall conform to the Caltrans Standard Specifications.

Extra metal thickness for aluminum pipes may be required when flow velocities exceed 5 fps.

**15.05 Strength Requirements:** The strength requirements for metal pipe fabricated under acceptable methods contained in the Caltrans Standard Specifications shall be governed by charts published by Caltrans and contained within their Highway Design Manual, latest edition. The minimum metal thickness for any pipe located within the roadway prism shall be 14 gauge.

**15.06 Reinforced Concrete Pipe (round or oval):** Reinforced Concrete Pipe shall conform to the provisions in Section 65 of the Caltrans Standard Specifications and Caltrans Standard Plans.

**15.07 Cast In Place Concrete Pipe:** Cast in place concrete pipe shall conform to the County Standard Specifications and specifications published by the Riverside County Flood Control and Water Conservation District.

## **16. CONCRETE CURB AND GUTTER AND SIDEWALK**

**16.01 Concrete Curbs and Sidewalks, etc.:** Portland Cement Concrete curbs, gutters, sidewalks, curb ramps, cross-gutters, spandrels, driveway approaches and other items listed in the table below shall conform to the provisions in Section 73 of the Caltrans Standard Specifications and County Standard Specifications. Each type of structure shall comply with the minimum cementitious material content shown in the following table.

Type of Structure	Cementitious Material Content* (lb/cu yd)	County Road Standard Number
-------------------	---	-----------------------------

Landscaped Median Maintenance Walk (and other median concrete paving)	505	113
Crossover Median	590	113A
Curb & Gutter (Type A-6, A-8, C, W)	505	200, 201, 202, 202A
Curb only (Type D-1, D)		203, 204
Curb Transition		211
Residential Drive Approach	505	206, 207, 213
Commercial Drive Approach	590	207A
Cross Gutter, Spandrel	590	209, 210
Flat Outlet Drainage Structure	505	303
PCC Dip Section	590	307
Curb Outlet Drain	505	308
Under Sidewalk Drain (Cast in Place)		309
Private Drain Through Curb		310
Gutter Depression	505	
Curb Opening		311
Grate Opening		312
Sidewalk, Fire Hydrant and Utility Pole	505	400
Sidewalk and Curb	505	401
Curb Ramp	505	403
Meandering Sidewalk	505	404
Alley and Alley Apron	590	500
Multiple Mailbox Installation (sidewalk)	505	812, 813
Bus Turnout	590	814
Minor Concrete not specified	505	

\*Higher cement content shown on plans or in these specifications shall govern

- 16.02 Joints:** Expansion joints shall be 1/2" wide and shall use a preformed expansion joint filler material.
- 16.03 Expansive Soil:** Where the soils report indicates the presence of expansive soils, or the soil indicates an R-value less than 10 and a Plasticity Index greater than 10, place a minimum of 6 inches of Class 2 Aggregate Base as directed by the Engineer under all concrete improvements and structures listed in the table in Section 16.01 .
- 16.04 High Sulfate Soil:** High Sulfate soils are damaging to Portland Cement Concrete improvements and are defined as those soils where the Water-Soluble Sulfate in soil is greater than 0.10 percent. For soils with high sulfate content, use the following table to determine actual cement content and requirements for concrete work. In those areas where the soils report indicates the Water-Soluble Sulfate is greater than 0.20 percent, provide a minimum of 6 inches of Class 2 Aggregate Base material and a layer of 6 mil plastic sheeting under and around all concrete improvements and structures listed in the table in Section 16.01, as well as street light foundations, signal pole foundations, catch basins, riprap energy dissipators, pre-cast concrete manholes, and other pre-cast concrete items. The plastic sheeting shall be placed between the aggregate base and the compacted native soil.

Degree of Sulfate Attack	Water-Soluble Sulfate (as SO <sub>4</sub> ) in Soil Samples (%)	p.p.m. Sulfate (as SO <sub>4</sub> ) in Water Samples	Cement Type	Cement Content Lbs/Cuyd	Aggregate Base Required
--------------------------	---	---	-------------	-------------------------	-------------------------

Negligible	0.00 to < 0.10	0 to 150	II	Sec 90	No
Moderate	0.10 to < 0.20	150 to 1000	II	590	No
Considerable	0.20 to 0.50	1000 to 2000	V	675	Yes* <sup>d</sup>
Severe	Over 0.50	Over 2000	V+SCM	675	Yes* <sup>d</sup>

<sup>a</sup> maximum water to cement ratio of 0.50 with Type II Portland cement.

<sup>b</sup> maximum water to cement ratio of 0.45 with Type V Portland cement.

<sup>c</sup> maximum water to cement ratio of 0.40 with Type V Portland cement and Supplementary Cementitious Materials (SCM) per Caltrans Standard Specification 90-1.02H.

<sup>d</sup> 6 mil plastic sheeting and Class 2 Aggregate Base to be placed under and around all concrete improvements and structures identified in this Section 16.04.

**16.05 Compaction:** Relative compaction of Subgrade shall be 95% minimum for concrete improvements subject to vehicle loading, including curbs, curb and gutter, driveway approaches, cross-gutters, spandrels, local depressions, median crossovers, low water crossing dip sections, alley aprons and bus turnouts. Relative compaction of Subgrade shall be 90% minimum for those concrete improvements not subject to vehicle loading, including sidewalks, curb ramps, landscaped median maintenance walks (and other median concrete paving), and undersidewalk drains.

**16.06 Multiple Mailbox Installation for New or Existing Sidewalk:** Sidewalk and mailbox foundation shall conform to County Road Standard No. 812 or No. 813, whichever applies. Specifications for mailboxes to be furnished by the Postmaster.

**16.07 Returned Plastic Concrete:** The use of Returned Plastic Concrete (RPC) may be allowed for minor concrete application and in conformance to Section 90-9 of the Caltrans Standard Specifications. If used, the quantity of RPC added to the concrete shall not exceed 15 percent.

## 17. SEWERS

**17.01 Description:** The sanitary sewers for the subdivision shall be constructed in accordance with the Plans as approved by the Director of Transportation and the Health Department. All plans shall be signed by a registered civil engineer under whose direction the Plans and Project Specifications were prepared. Approval of the operating agency or District shall also be provided.

This section is for the purpose of defining the minimum requirements for the construction of sanitary sewers and is not intended to prohibit the use of any material and methods of construction not specified herein, provided such alternate is approved by the Health Department. In those cases in which utility companies have specified construction standards pertaining to their utility, standards of the utility company shall be accepted in lieu of the County standards specified herein, excepting trench compaction and pavement restoration in County roads.

**17.02 Scope of Work:** The work under this section shall include all work required to complete the construction and testing of all facilities necessary for the satisfactory operation and protection of the system as shown on the Plans.

**17.03 Sewer Pipe:** All sizes of sewer pipe shall conform to the applicable requirements of Section 207 of the "Greenbook", Standard Specifications for Public Works Construction, latest revision. All

lining of pipe shall be in accordance with the requirements of the supervising agency and shall be approved by the Director of Transportation and the Riverside County Health Department. Plastic pipe shall conform to ASTM D-3034.

**17.04 Installation:** The installation of on-site main lines and outfalls shall be within the dedicated road right-of-way except where easements are necessary to provide a gravity flow system and shall be in accordance with requirements and standards of the County of Riverside.

**17.05 Manholes and Structures:** All manholes and structures, either precast or built up, to be installed within the roadway, shall be designed for a minimum AASHTO H-20 highway loading and shall conform to the requirements of Section 70-4 of the Caltrans Standard Specifications and Section 403-3 of the "Greenbook", Standard Specifications for Public Works Construction.

**17.06 Sewer Connections:** Unless otherwise permitted by the Director of Transportation and Health Department, sewer connections shall be laid in straight lines from the main sewers to a point beyond the curb or to the property line at the time of the laying of the mains in accordance with the approved sewer plans or Improvement Standards.

The Contractor shall place "Y" branches of the size and in the positions shown on the approved Plans, and the house connection lines shall be placed to the lines and grades shown thereon. Connections to be stubbed off shall be closed at their outer end with an approved stopper and cement grout.

**17.07 Testing of Sewers:** After completion of construction of sewers and manholes, the system shall be tested in accordance with the requirements of the sewer purveyor.

**17.08 Separation of Water Mains and Sanitary Sewers:** Water mains and sanitary sewers shall conform to the criteria as outlined and illustrated in the State of California, Department of Health Services' publication "Criteria for the Separation of Water Mains and Sanitary Sewers", latest edition; and the "California Waterworks Standards", Section 64630, Title 22, California Administrative Code.

The "California Waterworks Standards" sets forth the minimum separation requirements for water mains and sewer lines. These Standards, contained in Section 64630, Title 22, California Administrative Code, specify:

- A. Parallel Construction: The horizontal distances between pressure water mains and sewer lines shall be at least 10 feet.
- B. Perpendicular Construction (Crossing): Pressure water mains shall be at least one foot above sanitary sewer lines where these lines must cross.
- C. Separation distances specified in A and B shall be measured from the nearest edges of the facilities (i.e., dimensions are from outside of water main to outside of sewer line or manhole).
- D. Common trench: Water mains and sewer lines must not be installed in the same trench. The lack of separation between water mains and sanitary sewers results in an increased potential for contamination of the water supply. Therefore, when adequate physical separation cannot be attained, an increase in the factor of safety should be provided by increasing the structural integrity of both the pipe materials and joints required herein.

**17.09 Backfill Requirements:** Pipe backfill shall be placed in accordance with the "Greenbook", Standard Specifications for Public Works Construction Section 306-12, Backfill. The Contractor/Utility Owner shall provide a written report of trench compaction results signed by an Engineer registered in the State of California and competent in the Geotechnical Engineering field along with copies of the daily testing reports prior to paving operations taking place. Testing frequency shall be a minimum of one relative compaction test for every two feet of depth of trench per 200 lineal feet of trench. For example: 1,600 foot trench by 6 foot deep will have a minimum of 24 relative compaction tests. The testing frequency of laterals shall be one out of every two alternating between long and short.

## **18. WATER PIPELINES**

**18.01 Description:** The water supply system for the subdivision shall be constructed in accordance with the Plans as approved by the Director of Transportation and Health Department. All plans shall be signed by a registered civil engineer under whose direction the Plans and Project Specifications were prepared and shall bear evidence of approval of the operating agency or District.

This section is for the purpose of defining the minimum requirements for the construction of water supply and distribution systems and is not intended to prevent the use of any material or method of construction not specified herein, provided such alternate is approved by the Director of Transportation and Health Department. Water facilities shall be designed and constructed in accordance with applicable requirements of either the California Section of AWWA or the Public Utilities Commission. In those in which utility companies have specific construction standards pertaining to their utility, standards of the utility companies shall be accepted in lieu of the County Standards specified herein, excepting trench compaction and pavement restoration in County roads.

**18.02 Scope of Work:** The work under this section shall include all work required to complete the construction and testing of all facilities necessary for the satisfactory operation and protection of the system as shown on the Plans.

**18.03 Materials:** All materials shall be of the sizes and classes as shown on the approved Plans and shall conform to the latest revision of the following Specifications and Standards. All materials shall be new, unless specifically approved by both County agencies involved.

- A. CAST IRON PIPE. Shall conform to AWWA C102, AWWA C106, AWWA C108.
- B. CEMENT-ASBESTOS PIPE. Shall conform to AWWA C400, with the selection of Class of pipe based on AWWA Manual H2.
- C. STEEL PIPE. Shall conform to AWWA C201, AWWA C202, or Federal Specification SS-P-385.
- D. CONCRETE PIPE. Shall conform to AWWA C300, AWWA C301, or Federal Specifications SS-P-381.
- E. PLASTIC PIPE. Shall conform to AWWA C900.

F. LININGS AND COATING. Minimum protective coating shall be asphalt dipped and asphalt felt wrapped. All coal-tar and cement mortar linings and coatings so designated on the Plans or stated in the Project Specifications shall conform to AWWA C104, AWWA C203, or AWWA C205, whichever is applicable. Asphalt mastic coatings shall conform to Specifications M-2 (CS-96) of the Asphalt Institute.

G. FITTINGS AND SPECIALS. Shall conform to the applicable sections of AWWA C100, AWWA C110, AWWA C207, AWWA C208, or other approved standard or specification under which the fitting or special is made.

**18.04 Installation:** The installation of on-site pipelines shall be within the road right-of-way of County roads except where easements are necessary to provide a circulating system and shall be in accordance with the requirements and standards of the County of Riverside.

Trenching, installation, and backfilling shall be in accordance with the applicable requirements of County Standard Specifications, County Road Standards, and the recommendations of the pipe manufacturer.

**18.05 Backfill Requirements:** Pipe backfill shall be placed in accordance with the "Greenbook", Standard Specifications for Public Works Construction Section 306-12, Backfill. The Contractor/Utility Owner shall provide a written report of trench compaction results signed by an Engineer registered in the State of California and competent in the Geotechnical Engineering field along with copies of the daily testing reports prior to paving operations taking place. Testing frequency shall be a minimum of one relative compaction test for every two feet of depth of trench per 200 lineal feet of trench. For example: 1,600 foot trench by 6 foot deep will have a minimum of 24 relative compaction tests. The testing frequency of laterals shall be one out of every two alternating between long and short.

**18.06 Structures:** Any structures necessary for the completion of the water supply system shall be constructed in conformity with the Plans and in accordance with applicable provisions of these standards. Concrete structures shall be constructed of minor concrete conforming to provisions in Section 90-2 of the Caltrans Standard Specifications.

**18.07 Fire Hydrants:** Unless specifically excluded from the Agreement, all water systems shall include fire hydrants installed in conformance with the subdivision Improvement Standards and at locations shown on the Plans.

**18.08 Valve Casings:** All valve stems shall be cased and provided with removable covers in accordance with the subdivision improvements standards. When located in a paved area, cover shall be flush with surfacing. Covers are to be set to the finished surface grade at the time asphalt concrete or sealcoat is placed.

**18.09 Hydrostatic Test and Disinfection of System:** After completion of the connections, the system shall be tested by the admission of water under not less than the full working pressure of the lines. All joints, valves, connections, and fittings shall then be visually inspected for leakage, or the pipe lines backfilled and a leakage tests made to determine the rate of leakage. The allowable rate of leakage shall not exceed 25 gallons per 24 hours per inch of diameter per mile of pipe. All leaks shall be repaired to the satisfaction of the Engineer.

Disinfection of the lines may be accomplished at this time by the inclusion of the disinfection solution to the water used for the test. All lines shall be flushed and disinfected in accordance

with AWWA C601 prior to Acceptance of the system. Lines shall be thoroughly flushed after treatment with disinfectant prior to being placed in service.

## **19. UNDERGROUND UTILITY INSTALLATION**

**19.01 General:** All new and existing utility lines, including but not limited to, electrical service, communications and street lights conduits will be placed underground. The Developer shall make the necessary arrangements with the serving utilities for the installation of such facilities. Surface mounted transformers, pedestal mounted terminal boxes and meter cabinets, ducts, street lighting, signal control cabinets, and other associated equipment in an underground utility system may be placed above ground in accordance with the County Road Standards and County Standard Specifications herein and the requirements of a County Encroachment Permit.

All overhead communications conductors, and all overhead electrical distribution conductors, which exist on a road or easement to be improved by any land division and commercial development, which is subject to discretionary approval by the County of Riverside, shall be relocated to an underground location, except for overhead electrical circuits which exceed 34 Kilovolts.

The Director of Transportation may waive any of the above requirements if topographical, soil, economic, or any other conditions make such underground installations unreasonable or impractical.

**19.02 Underground Installations:** All underground facilities, including laterals, shall be in place and tested prior to backfilling and paving the street section, including, but not limited to, the following: sewer, water, electric, gas, drainage, communications, cable TV, and irrigation. The Contractor shall provide written verification from the affected utilities of acceptable test results prior to proceeding with backfilling and paving operation. If more than one cable TV company serves an area, cables for all TV companies shall be installed prior to paving of the street section or underground ducts shall be provided by the developer on all street intersections as such to provide future installation of TV cables in accordance with Standard No. 819 of the County Road Standards.

**19.03 Surface Installations:** All above ground appurtenances shall be placed so that no part of the appurtenance is less than 18 inches from curb face and must maintain a minimum 6 foot of sidewalk width per County Road Standards to meet ADA requirements. Where no curb is present, above ground appurtenances shall be placed so that no part of the appurtenance is less than 8 feet from the edge of traveled way.

## **20. STREET NAME SIGNS**

**20.01 General:** Street name sign shall conform to the latest edition of State of California Manual on Uniform Traffic Control Devices (CA MUTCD) and these Special Provisions.

The Developer or its Agent shall fund the installation of street name signs in accordance with applicable County Standard No. 1220, 1221, and 1222.

- 20.02 Street Name Sign Plates:** Sign plate size, color, material and finish, and lettering sizes shall be in accordance with applicable County Standard No. 1220 or 1221.
- 20.03 Bracket Assembly:** Sign post cap and center cross saddle's size and material shall be in accordance with applicable County Standard No. 1220 or 1221.
- 20.04 Sign Posts:** Sign post size, material and installation method shall be in accordance with County Standard No. 1222.
- 20.05 Sign Locations:** Number of complete street name sign assembly per intersection shall be in accordance with applicable County Standard No. 1220 or 1221.

## **21. LAND SURVEY MONUMENTS**

- 21.01 General Requirements:** The subdivision boundaries, lot corners, road, street, highway centerline, angle points in all lines, beginning and end of all curved lines, shall be monumented in accordance with the hereinafter described standard monuments and procedures. Any monument having characteristics other than the hereinafter described may be used only upon written approval of the County Surveyor. If an existing record and identified monument is found on the ground at the location of a subdivision corner, this monument may be used in lieu of replacement with a new monument provided the existing monument is a type considered to be durable.

*Due to fires, hot dry weather, floods, and other natural factors, the County Surveyor is no longer allowing the use of Plastic Plugs as durable monuments.*

- 21.02 Standard "A" Monuments:** This monument is to be one inch (inside diameter) iron pipe eighteen inches (18") long. A metal disc bearing the Registered Civil Engineer or Land Surveyor number shall be securely affixed to the top of the pipe. The top surface of the monument shall be flush with natural ground, flush with surface in paved streets and twelve inches (12") down in unpaved streets. See Monument Schedule and County Road Standard Drawing numbers 900, 901, and 903 for further information.
- 21.03 Standard "B" Monuments:** This monument is to be an eighteen inch (18") long copper clad steel pin, to which is secured at one end, a one and one-half inch (1-1/2") conical brass cap. The monument may be used as an alternate to the type "A" monument to mark centerline control on streets. The monument is to be driven flush with the street pavement. The Registered Civil Engineer or Land Surveyor number shall be stamped into the surface of the brass cap. Modification of the above standard may be approved by the County Surveyor. See Monument Schedule and County Road Standard drawing numbers 900, 901 and 903 for further information.
- 21.04 Standard "C" Monuments:** This monument to be of a 2" x 2" x 18" long redwood stake cut from clear heartwood firmly set in the ground. The exact point of intersection of the lines shall be marked on the top center of the stake by a suitable tack or nail, which in turn shall be used to secure to the stake the metal disk bearing the Registered Civil Engineer or Land Surveyor Number. A #5 (5/8") rebar, 18" long with appropriately stamped metal disk may be used in place of a redwood stake. The exact point of intersection of the lines shall be marked on the top center of the rebar, the Registered Civil Engineer or Land Surveyor number shall be stamped into the surface of the cap. Modification of the above standard may be approved by the County Surveyor.



See Monument Schedule and County Road Standard drawing numbers 900, 901 and 903 for further information.

**21.05 Standard "D" Monuments:** This monument to consist of a 3/4" inside diameter x 18" long galvanized iron pipe, driven to a point not to exceed 1" above the natural ground surface. The exact point of intersection of the lines shall be marked on the top center of the pipe by a suitable tack or nail, which in turn shall be used to secure to the pipe the metal disk bearing the Registered Civil Engineer or Land Surveyor Number with mark for exact point. See Monument Schedule and County Road Standard drawing numbers 900, 901 and 903 for further information.

**21.06 Standard "E" Monuments:** This monument to be of a metal identification disc bearing the Registered Civil Engineer or Land Surveyor Number that is set with a lead plug or steel pin set in concrete curb. See Monument Schedule and County Road Standard drawing numbers 900, 901 and 903 for further information.

**21.07 Monument Schedule:**

STANDARD	USE OF MONUMENT	REMARKS
"A"	Tract boundary control, street centerline control-unpaved and paved.	As specified by the County Surveyor
"B"	Street centerline control.	May be used in lieu of Type "A" monument in paved streets.
"C"	Lot corner, angle point in lot line, E. C. and B. C. lot line, and right-of-way line.	
"D"	Same as "C"	
"E"	Same as "D"	All lot corner monuments except when lot corner is coincident with boundary corner may be set in the top of the curb on the prolongation of the lot line or radial/perpendicular from the centerline at a specified distance as noted on the final map. In the event improvements in a subdivision include a block wall along the rear lot lines, a Standard "E" monument shall be set on both sides of the block wall to indicate direction of the side lot lines Such points shall be noted on the final map as "point on line". Otherwise all rear corners shall be set at the true corner location.

**21.08 Monument Ties:** Upon completion of the tract monumentation, the Registered Civil Engineer or Licensed Land Surveyor shall furnish to the County Surveyor ties to all street centerline monuments. Such ties are to be permanent physical objects, there being not less than four ties to each monument. Effort should be made to set ties with strong angular relationship, as close to

90° angles as practical. Additionally, consideration should be given to utilizing lot corner monuments as tie points.

Whenever curb-and-gutter is installed, street centerline monuments are to be tied to permanent points set in the curb, these permanent points to consist of a metal identification disc bearing the Registered Civil Engineer or Land Surveyor Number that is set with either of the following: lead and tack (L&T) or steel pin driven into the concrete. Use of a cross cut in the concrete will not be acceptable. Cross over ties are preferred when made with a total station and tape. The ties furnished to the County Surveyor are to be prepared on 8-1/2" x 11" sheets of paper. Sketch to be clear and legible and spaced to avoid confusion or misinterpretation.

## **22. STREET LIGHTING**

**22.01 General:** Street light system shall conform to the latest National Electrical Code; the Electrical Safety Orders of the Division of Industrial Safety, Department of Industrial Safety, State of California; and shall conform to approved standards and procedures of the local servicing utility, and requirements of this section.

The Developer or its Agent shall fund the installation of street lightings and service connection when conditioned by the County of Riverside Transportation Department (Engineer).

Service Agreement between the Developer and serving utility shall define the serving utility as the owner of the streets lights who is liable of maintaining the street lights.

### **22.02 Special Provisions:**

All street lighting shall conform to the following:

- A. Street lights shall be installed at intersections near the curb return at a far right approach
- B. Street lights shall be installed at a minimum of one street light for each 200-lineal feet of roadway, plus or minus 20 feet
- C. Street light luminaires shall be full cut off, light emitting diodes (LED) type with color temperature of:
  1. 4000K when the project is located outside of the 30-mile radius of Mt. Palomar Observatory
  2. 3000K color temperature if the project is located within the 30-mile radius of Mt. Palomar Observatory, or
  3. As directed by the Engineer
- D. Private lighting shall conform to County Ordinance No. 655 for private lighting regulation within 45-mile radius of Mt. Palomar Observatory and County Ordinance No. 915 for reducing outdoor light trespass
- E. Selection of street light pole height and luminaire wattage shall be in accordance with applicable County Standard No. 1000 or 1001
- F. Street light pole material shall be in accordance with the following:

1. Ornamental concrete type shall be considered as the standard street lighting pole type
  2. Other street lighting pole types or mast arm lengths may be used if mutually agreed upon by the Director of Transportation and the serving utility
- G. Street lighting shall be required on all County of Riverside expressway classification roadways in accordance with County design criteria and the following:
1. At-grade intersections
  2. Grade separations of expressways with other public roadways, railways, pedestrian walkways, and with other public or private facilities
  3. Acceleration and deceleration ramps and lanes
  4. Auxiliary lanes

The above-described requirements shall apply to County designated expressway classification roadways with access openings at spacing not less than the intersection intervals designated in County Standard No. 114. Said roadway shall be provided with physical controlled access barriers such as fences and block walls. In the absence of such physical access barriers, or if the access intervals are less than that set forth in Standard 114, the roadway shall not be considered as an expressway for purposes of street lighting, and street lighting shall therefore be installed at 200-foot spacing in accordance with the requirements of the County's Transportation Department and this section.

- H. Requests for street light layouts shall be submitted to the Transportation Department. Specific procedures and design criteria shall be in accordance with those established by the Transportation Department, the County Administrative Office and the serving utility.

### **23. TRAFFIC SIGNAL AND HIGHWAY LIGHTING SYSTEM**

**23.01 General:** Traffic signal and highway lighting system shall conform to the following:

- A. Latest edition of California Manual on Uniform Traffic Control Device (CA MUTCD)
- B. Latest edition of Caltrans Standard Plans and Caltrans Standard Specifications
- C. Latest edition of County of Riverside Transportation Department Traffic Signal Construction Specifications (County Standard Specifications)
- D. Requirements of this section

Traffic signal plan shall identify which edition of the CA MUTCD, Caltrans Standard Plans, Caltrans Standard Specification, and County Standard Specifications that the traffic signal plan conformed to.

Traffic signal plan shall be amended to conform to the latest standards/specifications when Developer or its Agent did not secure encroachment permit for the project within 18 months of County of Riverside Transportation Department (Engineer) approving the plan.

Engineer shall review and approve project specific Special Provisions, including requirements of other public agencies that have an owning interest in the planned improvements that were not covered under this section.

The Developer or its Agent shall arrange and fund the following:

- A. Relocation of all conflicting utilities
- E. Electrical service connection
- F. Furnish and install the traffic signal and highway lighting system

**23.02 Quality Assurance:** Electrical equipment shall conform to the provisions in Section 86-1.01D, "Quality Assurance", of the Caltrans Standard Specifications and conform to the County Standard Specifications.

All furnished equipment shall be new

**23.03 Warranties, Guaranties, Instruction Sheets, and Manuals:** Warranties, guaranties and instruction sheets shall conform to these Special Provisions.

Minimum manufacturer warranty period:

- A. Light Emitting Diodes (LED) modules shall have five (5) years of manufacturer warranty
- B. Battery Backup System (BBS) shall have five (5) years of manufacturer warranty. The first three (3) years shall be termed the "Advanced Replacement Program". Under this program, the manufacturer will send out a replacement within two business days of the call notifying them of an issue. The replacement unit may be either a new unit or a re-manufactured unit that is up to the latest revision. The last two years of the warranty will be factory-repair warranty for parts and labor on the BBS.
- C. Video Detection System shall have three (3) years of manufacturer warranty. During the warranty period, technical support from factory-certified personnel or factory-certified installers shall be available via telephone within four (4) hours of the time when a service call is made.
- D. Internally illuminated LED street name sign shall have two (2) year of manufacturer warranty
- E. All other equipment and systems shall have at least one (1) year of manufacturer warranty

Furnished the following documents to Engineer:

- A. Manufacturer warranty
- F. Manufacturer standard written warranty pertaining to defects in materials and workmanship for all equipment
- G. Two (2) sets of user, operation, and maintenance manuals, written in English, on all equipment and components for the traffic signal and highway lighting system shall be furnished to the Engineer

**23.04 Equipment Wiring Diagrams:** Controller cabinet assembly diagrams shall conform to these Special Provisions.

The equipment wiring diagrams shall include the wiring diagrams of the following applicable equipment/systems:

- A. Controller cabinet assembly
- B. Traffic signal controller(s)
- C. Battery backup system
- D. Video detection system
- E. Emergency vehicle preemption system
- F. Railroad preemption system
- G. Signal Interconnect
- H. Radio and Ethernet network communication system

Contractor shall furnish four (4) complete sets of equipment wiring diagrams to the Engineer. The controller cabinet assembly wiring diagram shall include an approximately 6" x 8" drawing of the project intersection with the following information, at a minimum:

- A. North arrow
- I. Street names
- J. Pavement delineation and markings
- K. Signal poles
- L. Traffic signal heads with phase designations
- M. Pedestrian signal heads with phase designations
- N. Video detection zones/loop detectors with input file designations

Contractor shall submit manufacturers' maintenance manual or combined maintenance and operation manual as an informational submittal. The manual must have a master item index that includes:

- A. Specifications
- O. Design Characteristics
- P. General Operation Theory
- Q. Function of all controls
- R. Troubleshooting Procedure
- S. Parts List, Descriptions, Stock Numbers, and Settings
- T. Block Circuit Diagram
- U. Layout of Components
- V. Schematic Diagrams

**23.05 Temporary Electrical Systems:** Temporary Electrical Systems shall conform to the provisions in Section 87-20, "Temporary Electrical Systems", of the Caltrans Standard Specifications and

these Special Provisions. Temporary wood poles shall conform to the provisions in Section 48-6, "Temporary Wood Poles" and County Standard Specifications.

A temporary electrical system consisting of the traffic signal and safety lighting system shall operate on a continuous basis using either new or used equipment that meets the latest standards /specifications.

Contractor shall obtain Engineer's authorization for the following temporary electrical systems and its installation method:

- B. Temporary signal with steel base plate and weights per City of Los Angeles Standard S-57.2C;
- A. Temporary wood poles, guyed with no signals on span cables, per Caltrans Standard Plan ES-18C, and/or guyed with signal faces on span cables, per Caltrans Standard Plan ES-18D, and
- B. Temporary overhead conductors for temporary signal operation.

**23.06 Maintaining Existing Electrical System:** Maintaining Existing Electrical System: Maintaining existing electrical systems shall conform to the provisions in Section 87-21.03B, "Maintaining Existing Electrical Systems", of the Caltrans Standard Specifications and County Standard Specifications.

Authorization and coordination from the Engineer is required for each traffic signal system shutdown. Traffic signal system shutdown shall be limited to hours between 9:00 A.M. and 3:00 P.M.

Equip existing flashing beacons with portable flashing beacons during flashing beacon shutdown. Portable flashing beacons shall conform to the provisions in Section 12-3.05, "Portable Flashing Beacons" of the Caltrans Standard Specifications or as directed by the Engineer.

If directed by the Engineer, a generator shall be furnished, connected, and maintained to keep traffic signal or flashing beacon system running in normal operation. All matters pertaining to the operation of existing traffic signal equipment shall be coordinated and cooperated with the County of Riverside traffic signal operation division.

Temporary "Stop" signs furnished and installed when traffic signal system is shutdown shall be 36 inches in size.

Temporary "Stop Ahead" signs furnished and installed when traffic signal system is shutdown shall be equipped with portable flashing beacons.

**23.07 Removing Existing Electrical Equipment:** The Contractor shall remove existing electrical systems as shown on plan(s). For any pole or cabinet that is removed, the unused foundation must also be removed.

**23.08 Foundations:** Foundations shall conform to the provisions in Section 51, "Concrete Structures", Section 56-3.01C(2), "Foundations", and Section 87-1.03E(3), "Concrete Pads, Foundations, and Pedestals", of the Caltrans Standard Specifications and County Standard Specifications.

**23.09 Standards, Poles, Steel Pedestals and Posts:** Standards, poles, steel pedestals, and posts shall conform to the provisions in Section 56-3, "Standards, Poles, Pedestals, and Posts", and

Section 87-1.03J, "Standards, Poles, Steel Pedestals and Posts", of the Standard Specifications and County Standard Specifications.

- 23.10 Conduit:** Conduit shall conform to the provisions in Section 86-1.02B, "Conduit and Accessories", and 87-1.03B, "Conduit Installation", of the Caltrans Standard Specifications and County Standard Specifications.
- 23.11 Pull Boxes:** Pull boxes shall conform to the provisions in Section 86-1.02C, "Pull Boxes", of the Caltrans Standard Specifications and County Standard Specifications.
- 23.12 Conductors and Cables:** Conductors and Cables shall conform to the provisions in Section 86-1.02F, "Conductors and Cables", of the Caltrans Standard Specifications and County Standard Specifications.
- 23.13 Signal Interconnect Cable:** Signal Interconnect Cable shall conform to the provisions in Section 86-1.02F(3)(d)(v), "Signal Interconnect Cable" of the Caltrans Standard Specifications and County Standard Specifications.
- 23.14 Fiber Optic Cable:** Fiber Optic cable shall conform to the provisions in Section 87-19.02C "Fiber Optic Cable", of the Caltrans Standard Specifications and County Standard Specifications.
- 23.15 Bonding and Grounding:** Bonding and grounding shall conform to the provisions in Section 86-1.02F(1)(c)(ii), "Bonding Jumpers and Equipment Grounding Conductors", of the Caltrans Standard Specifications and County Standard Specifications.
- 23.16 Service:** Service shall conform to the provisions in Section 86-1.02P(2), "Service Equipment Enclosures", Section 87-1.03L, "Utility Service", Section 87-1.03P, "Service Equipment Enclosures", Section 86-2.11, "Service", of the Caltrans Standard Specifications and County Standard Specifications.
- 23.17 Testing:** Testing and Field Testing shall conform to the provisions in Section 87-1.02D(2), "Quality Control", of the Caltrans Standard Specifications and County Standard Specifications.

Specific testing requirements for various systems and components shall be in accordance with the County Standard Specifications entitled to each herein.

The complete controller assembly and Battery Backup System shall be delivered to the following location or location as directed by the Engineer for testing:

Traffic Signal Shop  
Riverside County Transportation Department  
McKenzie Highway Operations Center  
2950 Washington Street  
Riverside, California 92504  
Telephone (951) 955-6894

A minimum of 15 working days for operational testing and adjustment is required. An additional 15 working days period shall be allowed for retesting should the equipment fail.

The conflict monitor unit shall be tested in the field before signal turn on.

- 23.18 Controller Assembly:** Controller assembly shall conform to the provisions in Section 86-3, "Controller Assemblies", of the Caltrans Standard Specifications and County Standard Specifications.
- 23.19 Wireless Radio System:** Wireless radio system shall conform to County Standard Specifications.
- 23.20 Vehicle Signal Assemblies:** Vehicle signal assemblies and auxiliary equipment shall conform to the provisions in Section 86-1.02R(4), "Signal Faces", of the Caltrans Standard Specifications and County Standard Specifications.
- 23.21 Pedestrian Signal Assemblies:** Pedestrian signal assemblies shall conform to the provisions in Section 86-1.02S, "Pedestrian Signal Heads", of the Caltrans Standard Specifications and County Standard Specifications.
- 23.22 Pedestrian, Bicycle and Equestrian Push Buttons:** Pedestrian, bicycle, and equestrian push buttons shall conform to the provisions in Section 86-1.02U, "Push Button Assemblies", of the Caltrans Standard Specifications and County Standard Specifications.
- 23.23 Accessible Pedestrian Signals:** Accessible Pedestrian Signals shall conform to the provisions in Section 86-1.02T, "Accessible Pedestrian Signals", of the Caltrans Standard Specifications and County Standard Specifications.
- 23.24 Detectors:** Detectors shall conform to the provisions in Section 87.103V, "Detectors", of the Caltrans Standard Specifications and County Standard Specifications.
- 23.25 LED Luminaires:** Luminaires shall conform to the provisions in Section 86-1.02K (2), "LED Luminaires", of the Caltrans Standard Specifications and County Standard Specifications.
- 23.26 Sign Illumination Systems:** Sign lighting fixtures shall conform to the provisions in Sections 87-3, "Sign Illumination Systems", of the Caltrans Standard Specifications and County Standard Specifications.
- 23.27 Internally Illuminated Street Name Sign:** Internally illuminated street name signs (IISNS) shall conform to the provisions in Section 87-4.02C, "Internally Illuminated Street Name Signs", of the Caltrans Standard Specifications and County Standard Specifications.
- 23.28 Photoelectric Controls:** Photoelectric controls shall conform to the provisions in Section 86-1.02M, "Photoelectric Controls", of the Caltrans Standard Specifications and County Standard Specifications.
- 23.29 Emergency Vehicle Preemption System:** Furnish and install complete and functioning emergency vehicle preemption (EVP) system as intended per Plans, the manufacturer, and County Standard Specifications.
- 23.30 GPS Universal Time Source:** The GPS Universal Time Source shall conform to County Standard Specifications.
- 23.31 Battery Backup System:** The battery backup system (BBS) shall conform to County Standard Specifications.
- 23.32 Solar Powered Flashing Beacon System:** Solar powered flashing beacon system shall conform to the provisions in Section 87, "Electrical Systems" of the Caltrans Standard Specifications, Chapter 4K, Flashing Beacons, of the CA MUTCD and County Standard Specifications.



**23.33 Permits and Fees:** The Developer or its agent shall obtain and pay all necessary encroachment permits, utility services and fees prior to the start of work.

## **24. ROADWAY LANDSCAPING**

### **24.1 GENERAL**

**24.1.1 Authority:** The following standards and guidelines have been developed and approved for the administration of landscape encroachments as such encroachments relate to roadway landscaping (County Ordinance No. 499 and Resolution No. 89-44).

**24.1.2 Goals and Objectives:** The standards and guidelines contained in this section have been developed to establish a minimum standard of quality associated with landscaping within the County Maintained Road rights-of-way, public rights-of-way, retained lots, and common open space areas. It is the goal of the County to facilitate the implementation of landscape improvements that are adequately designed, properly installed, and can be efficiently maintained. The following objectives should be incorporated into proposed landscapes in County rights-of-way:

- A. Landscaped improvements shall not jeopardize the public health, safety, and welfare, or interfere with the dedicated uses within the public rights-of-way.
- B. Landscaping shall be the product of functional design, aesthetic and public safety enhancements with a strong regard for maintenance and maintenance costs in perpetuity.
- C. Landscaping shall utilize water conservation practices, technology, and techniques. County Ordinance 859.X (X being latest County approved revision) shall be followed. Hardscape treatments shall be considered in combination with planting. Plants shall have low water requirements. Irrigation systems shall be designed for the efficient application of water to the plants.
- D. The facilitation of plant establishment, continued plant growth, vigor, health, and maintenance shall be part of the design process.
- E. The standardization of landscape construction and installation through the extended use of the "County of Riverside Comprehensive Landscape Guidelines and Standards" and to reduce plan check and inspection costs.
- F. Preservation of natural landscape resources, such as specimen or endangered plants, water features, land forms, etc., shall be encouraged.

#### **24.1.3 Landscape Improvement Requirements**

- A. Any landscape improvements, in conjunction with street improvements for industrial, commercial, or residential developments, involving grading, Hard scape construction (concrete walks, etc.), installation of walls, fences, lighting, planting, or irrigation systems, within the County of Riverside road rights-of-way, must be shown on plans and submitted for review by the Transportation Department.

- B. Plan submittal is not required for individual single-family residential landscaping, unless the proposed landscape work includes berm construction, excavations (other than for sprinkler lines or planting), hardscapes, walls fences, lighting, rockeries, signage, or other obstructions within the right-of-way.
- C. Encroachment permits are required for any work within the rights-of-way that requires a plan submittal.
- D. All landscape work is required to meet the standards set forth in this document.
- E. Landscape plans shall be prepared by a landscape architect registered/licensed in California.

**24.1.4 Landscape Maintenance in Perpetuity**

- A. Prior to the Transportation Department approval of any landscape plans, responsibility for the continued landscape maintenance (in perpetuity) must be established. There are two (2) forms of maintenance responsibilities, public or private.

Private landscape maintenance is typically done by the owner of a single parcel and/or their appointed representative or HOA. Public landscape maintenance involves a landscape maintenance district (such as Lighting Maintenance District 89-1-Consolidated [L&LMD 89-14-C]) typically overseen by a municipality or Special District. L&LMD 89-1-C is administered by the County of Riverside Transportation Department.

For Residential (tract) developments, ongoing landscape maintenance shall be the responsibility of a County approved (public) landscape maintenance district for all reverse frontage areas, medians, and ingress/egress parkways adjacent to fence lines (side lots). Maintenance shall pertain to all areas within a development as approved on the landscaping plan and, with the exception of walls and monuments, shall include all landscape elements in the rights-of-way, not just planting and irrigation. HOAs are not permitted to maintain reverse frontage landscapes or medians within the County Maintained Road right-of-way. Monuments shall be placed in an easement solely for the purpose of the monument and maintenance of said monument. Lighting for monuments will only be covered by the L&LMD if the lighting is on approved L&LMD plans and noted in the budget. Repeated acts of vandalism will not be covered by the L&LMD once budgeted monies are exhausted.

For commercial and industrial projects, ongoing landscape maintenance shall be the responsibility of a private entity if approved by the County of Riverside Transportation Department by an executed Landscaping Maintenance Agreement. Otherwise, ongoing landscape maintenance shall be done by a County approved landscape maintenance district. Maintenance responsibilities shall pertain to all areas within a development as approved on the landscaping plans, and shall include all landscape elements in the rights-of-way, not just planting and irrigation.

- B. Individual maintenance districts such as L&LMD 89-1-C, CSA, CFD, and Valley-Wide Recreation and Park District may have different requirements and standards in addition to those listed herein. Plans shall comply with pertinent standards and may need to be approved in conjunction with the associated maintenance district. In cases of discrepancy, the stricter requirements shall apply.

- C. Landscape areas shall be designed with respect to the maintenance mechanism utilized. Areas maintained by separate entities shall be designed so maintenance responsibilities do not overlap. Installation of a 6-inch-wide concrete header shall be required to clearly delineate maintenance boundaries.
- D. Areas maintained by separate entities shall have separate electrical and water meters, in separate enclosures/boxes. Special District Utilities shall be standalone.
- E. Parkways that have sidewalks that meander through the right-of-way area, dedicated landscape parkway easements or common areas contiguous to public rights-of-way shall be maintained by one maintenance entity for the entire area.

**24.1.5 Utility Location and Obstructions Below Ground:** Landscape designs shall consider all existing or proposed utilities, including but not limited to gas, sewer, water, storm drains, streetlights, and electrical. The locations of all known utilities shall be shown on the landscape plans. Contractor shall be responsible for having the location of all utility lines and structures verified by Underground Services Alert, or other utility locating service, so that proper precautions may be taken to avoid disruption of or damage to such improvements.

**24.1.6 Sight Distance:** The sight distance is the distance a driver approaching an intersection, whether signalized or not, or leaving a driveway should be able to see down the street for oncoming traffic. The area between the sight line and the curb is a restricted use area. No trees, plants, walls, or other obstructions higher than 18 inches from top of pavement (12" from top of curb) where ground is flat shall be placed in these restricted use areas (see County Road Standard 1101).

**24.1.7 Quality and Standards of Materials, Installation, and Guarantees**

- A. All landscape materials and installation procedures shall meet the minimum requirements as set forth in the "Greenbook", Standard Specifications for Public Works Construction, latest edition, and the County Standard Specifications contained in this document. Unacceptable materials or improper installation procedures shall be cause for rejection/removal of work.
- B. The County of Riverside Comprehensive Landscape Guidelines and Standards (referred to herein as "Guidelines") shall be used as a reference for current landscape construction within the rights of ways and adjacent landscape easements. The Guidelines are a dynamic document which is updated from time to time to reflect ever evolving Landscape Industry and Water District Regulations. When a conflict occurs between iterations of the Guidelines the stricter detail/standard/specification shall prevail. A current copy of The County of Riverside Comprehensive Landscape Guidelines and Standards may be found at: <https://rctlma.org/trans/Land-Development/Landscape-Development>
- C. All tree, shrub, and other woody plant work shall be completed in accordance with Approved American National Standard (ANSI) A300 and Z133 Standards, latest edition.
- D. Landscape maintenance districts may require additional plan check and inspection time and fees. The County may relinquish final inspection of the project to the County approved landscape maintenance district through written notification. The County will also seek written notice from the maintaining entity for their final Acceptance of the landscape improvements.

- E. Plant material shall be guaranteed for 90 days from time of landscape Acceptance by the County. Trees shall be guaranteed for one year from Acceptance date. Guarantees shall be in the form of bonds or cash deposits combined with written Agreements.
- F. Irrigation systems shall be guaranteed against material defects or improper installation methods for one year from acceptance date. Guarantees shall be in the form of bonds or cash deposits combined with written Agreements.

**24.1.8 Plant Material:** Plants shall be typical of their species or variety, have normal habits of growth, be healthy, vigorous, well rooted, but not rootbound or have girdling roots.

- A. Plants shall be free of disease, insects or pests, including their eggs or larvae.
- B. Plants with spines, thorns, or poisonous leaves, seeds, or berries, etc., are prohibited in areas adjacent to high pedestrian traffic. Plant selection shall be appropriate for the specific geographic location and climate zone in which they will be planted. Plants with thorns may be planted in areas where access is not warranted. Plant materials shall be selected from the "County of Riverside California Friendly Plant List" within The County of Riverside Comprehensive Landscape Guidelines and Standards.
- C. In order to comply with the County of Riverside objectives for attractive, low maintenance landscapes, the following characteristics shall be considered in plant selection:
  1. Appropriate growth habit and mature size for the intended planting area to avoid excess maintenance, such as frequent pruning or shearing to control growth. Minimal pruning and/or shearing for natural appearance is preferred.
  2. Drought tolerance, to minimize water usage.
  3. Fire resistance in natural fire hazard areas and fuel modification zones.
  4. Deep rooting properties.
  5. Hydrozone based design, grouping plants with similar water needs and other horticultural requirements.
- D. Trees shall be selected per the "County of Riverside California Friendly Plant List" within the County of Riverside Comprehensive Landscape Guidelines and Standards. Trees shall have straight, undamaged trunks, be well branched, well rooted without being rootbound, and have no girdling roots. Any old tree wounds shall be well healed or callused over. Minimum tree size shall be 15 gallons.
- E. Trees with aggressive roots shall be avoided. Approved root barriers (minimum 24" in depth) are required when trees are planted within certain distances from County maintained curbs, gutters, and/or sidewalks. See guidelines for specific requirements.
- F. Plants shall be non-invasive Refer to "County of Riverside California Friendly Plant List" within The County of Riverside Comprehensive Landscape Guidelines and Standards for a general listing of plants not allowed within various areas of the County.
- G. Trees shall not be topped (unless by governing utility as allowed by the PUC).

## **24.2 EROSION CONTROL AND LANDSCAPE GRADING PLANS**

**24.2.1 Erosion and Sediment Control:** Landscape designs shall comply with the County of Riverside Building and Safety Department's Grading Policy for Erosion Control Landscape Plans, Ordinance No. 457.

**24.2.2 Landscape Grading**

- A. Any grading in landscape areas shall be as shown on the grading plan.
- B. Parkway and common areas shall not drain onto private property.
- C. Medians shall be graded per County of Riverside Ordinance No. 461.
- D. Toe of slope shall not extend into any line of sight restricted use area (see County Road Standard 821).
- E. Hardscape grades shall be per County of Riverside codes and requirements. Desirable grades for landscape planting areas are indicated below.

Landscape	Minimum Slope	Maximum Slope	Comments
Shrub and Groundcover	2% (50H:1V)	50% (2H:1V)	If slope is 5:1 or steeper, the toe of slope shall be 1 foot away from any hardscape or wall.

- F. No grading shall be permitted within the drip line of existing trees indicated to remain and work shall be completed in compliance with Section 24.83.

**24.3 PARKWAY LANDSCAPING**

**24.3.1 Trees**

- A. Trees shall be selected "County of Riverside California Friendly Plant List" within County of Riverside Comprehensive Landscape Guidelines and Standards.
- B. Tree selection and design may be reviewed in relation to the species selected and the space in which it is to be planted. Factors to be considered are planting area size, proximity to utilities (above or below ground), growth rate and mature tree size, tree spacing, rooting characteristics, horticultural requirements, and maintenance needs.
- C. Trees located within the parkway shall be a minimum of 6 feet from the sidewalk edge, 6 feet or less from the sidewalk edge with a root barrier or as indicated within the County of Riverside Comprehensive Landscape Guidelines and Standards. In parkways without sidewalks, trees shall be planted a minimum of 7.5 feet from the face of curb. These conditions may vary for specific plans or special conditions approved by the Director of Transportation.
- D. The following standards shall apply in tree selection and location. Trees shall be:
  - 1. Planted on private property where feasible and street tree requirements are not required, a minimum of 2 feet from the right-of-way line on local and collector

streets. The exception shall be along the side yards (ingress/egress conditions) and backs of residential properties (reverse frontage) where a wall exists or is proposed. For all other street sections, trees shall be planted outside the rights-of-way if setback requirements can be met.

2. A minimum of 10 feet from residential driveways and 15 feet from commercial driveways (see County Road Standard 1101).
3. A minimum of 10 feet from corner cutbacks for local and collector streets, and 20 feet from corner cutbacks for secondary, major and arterial streets (see County Road Standard 1101).
4. A minimum of 3 feet from fences or the face of walls, either existing or proposed, and a minimum of 2 feet away from any wall footings.
5. A minimum of 6 feet from any underground utility line or vault, or per the particular utility, which may have further restrictions.
6. A minimum of 20 feet from street lights and 12 feet from traffic or street signs.

#### **24.3.2 Shrubs, Ground Covers, and Cactus**

- A. Shrubs, Ground Covers and Cactus shall be per "County of Riverside California Friendly Plant List" within The County of Riverside Comprehensive Landscape Guidelines and Standards.
- B. The minimum distance shrubs shall be planted from hardscape/sidewalk shall be equal to half the mature shrub's diameter. The minimum distance shrubs shall be planted from curbs shall be equal to the mature shrubs diameter. Ground cover may be planted up to the sidewalk or curb, depending on Ground cover trimming needs and suitability.
- C. Within the road right-of-way, no shrubs, ground covers, and cactus with a normal growth habit over 18 inches in height from top of pavement (12" from top of curb) may be planted within or encroach into any sight distance restricted use areas (see Standard 821).
- D. Where cactus are allowed in desert landscaping, cactus shall be placed so as not to encroach within 5' of any pedestrian or bike path areas at maturity.

#### **24.3.3 Vines**

- A. Vines shall be per "County of Riverside California Friendly Plant List" within The County of Riverside Comprehensive Landscape Guidelines and Standards.
- B. Vines shall be self-clinging or have an appropriate support system provided.
- C. A minimum of 18"-24" shall be left between any self-clinging and/or twining vines and shrubs or trees at their maturity.

#### **24.3.4 Lawn/Turf**

- A. Turf is only allowed in the right-of-way where it is contiguous with recreational park turf with no barriers present, in high pedestrian use areas such as schools, or as approved by the Transportation Director on a per case basis.
- B. Per Ordinance 859.3, turf is prohibited in the front yards of new residential tract developments prior to building permit final.

### **24.3.5 Sidewalks**

- A. Sidewalks shall be designed per Ordinance 461.
- B. Meandering sidewalks, that do not go to the curb, shall meander no closer than 3 feet to the face of the curb consistent with County Road Standard 404.
- C. Intersections with other walkways shall be designed to be located within one maintenance entity area. At the line where the walkway crosses into another maintenance area, an expansion joint shall be installed in the walkway (see Standard 400).

### **24.3.6 Mulch**

- A. All non-turf planting areas, except as noted herein, shall be mulched to retain moisture, suppress weeds, and moderate soil temperature. A granular pre-emergent shall be applied prior to mulching activities.
- B. Planting areas shall be mulched with a three inch (3") minimum layer of organic mulch. Areas of groundcover planted from flats shall be mulched with a one and one half inch (1-1/2") minimum layer of organic mulch. Organic mulch material shall be 3/8"-1/2" diameter screened fir bark or approved equal.
- C. Where maintenance districts require a different depth of mulch, the more stringent (deeper) requirement shall prevail.
- D. Color enhanced mulches shall not be used.
- E. Mulch may be omitted for native revegetation projects upon the recommendation of the project biologist.
- F. Mulch may be omitted for hydro-seeded areas.
- G. Slopes shall receive stabilizing mulch products per Ordinance 859.X (X being latest revision).
- H. Planting areas in desert regions (Sunset Climate Zones 11 and 13) shall be mulched with a two inch (2") layer of decomposed granite / gravel mulch. 1" minimum (sieve gradation/size) decomposed granite mulch shall be used.
- I. When used in lieu of mulch, cobble areas within the right-of-way shall be grouted in place unless maintained by commercial / industrial private entity.

### **24.3.7 Walls/Fences/Boulders**

- A. Walls or fences to be maintained by a maintenance district shall be designed to be located totally within the maintenance area of the maintenance district that will maintain the wall or fence. No private individual residential walls or fences, nor their footings shall be located within the County right-of-way.
- B. Walls shall be screened with vines to discourage graffiti. Vines shall be self-clinging or secured to a support. Vines should eventually provide a minimum wall screen of 80 percent coverage. Walls shall have a minimum of three (3) applications of anti-graffiti coating applied prior to any planting.

- C. Placement of Boulders within the right-of-way shall take into consideration sight distance zones, fall zones for cyclists, pedestrians, etc. A 10' clearance to pedestrian or bike path areas is recommended.

#### **24.3.8 Trail Stabilizer**

- A. Stabilizer product shall be appropriate for use by pedestrians, bicyclists and, where used for multi-purpose trails, equestrians.
- B. Subsurface for stabilized decomposed granite shall be prepared per product manufacturer specifications and warranty terms (compacted greater than 90% or Geotechnical Engineer's recommendation).
- C. Depth of stabilized decomposed granite to be a minimum of 50% of the overall trail section. The remaining section may be class 2 aggregate base as approved by the Director of Transportation.

### **24.4 MEDIAN LANDSCAPING**

**24.4.1 General:** Planting and irrigation is required for medians 5' wide or greater unless sight distance restricts planting. Median noses and transitions from turn lanes less than 24 inches shall be hardscape material. Irrigation shall be point source in nature, with 12" flexible riser with drip emitters or bubblers. Drip irrigation less than ½" pipe diameter and/or rated less than schedule 40/80 pipe is not permitted within medians.

#### **24.4.2 Median Hardscape**

- A. To reduce plant maintenance and conserve water, hardscape, rockeries, or other non-plant treatments shall be incorporated into the median design. As a general rule, a minimum of 40 percent of the median's plantable area shall receive hardscape treatment.
- B. Median hardscape shall be cobblestone river rock, 4" – 12" dia. and grouted with a min. thickness 4"; or colored concrete (with or without a stamped pattern) with a 4" min. thickness. Color shall be red, brown, sand, or tan. A gray or slate color is not permitted, since this color will not differentiate the median from the roadway.
- C. As a general rule, fixed objects such as boulders shall not be located in medians. In cases where special permission is granted, use shall be limited.
- D. Monument signs in medians may be allowed on a 'per case basis' with Transportation Department approval and will require a maintenance agreement. The Transportation Department will not be responsible for the maintenance and repairs/replacement to Monument signs.

#### **24.4.3 Median Trees**

- A. Trees shall be planted a minimum of 6 feet from the face of curb. Median must be a minimum of 12 feet wide for tree planting. Where trees are requested in a median less than 12 feet wide, root barriers are required.
- B. Trees shall be a minimum of 20 feet away from street lights and 10 feet away from traffic or street signs.



- C. Trees shall not be planted in median sight distance restricted use areas (see Standard 821)
- D. Trees planted in the median shall be from the County of Riverside California Friendly Plant List. Trees should be small diameter trunks and high canopies at full maturity.
- E. Tree 'clear trunk height' shall be 5' minimum above finish grade for viewing under foliage canopy of tree. If mature spread diameter of tree extends beyond the curb face, there shall be 14' minimum clearance above the road to the branching/foliage.
- F. Trees planting, location and size shall comply with Caltrans requirements for highways classified per County Standards 91, 92, 93 and Expressway.

**24.4.4 Median Shrubs and Ground Covers**

- A. Shrubs planted in a median shall be the low growing varieties. The shrubs normal growth habit shall not exceed 4 feet in height. Median shall be A minimum of 5 feet wide for shrub planting.
- B. Shrubs planted in the sight distance restricted use areas shall not have a growth habit exceeding 18 inches in height from top of roadway (12" from top of curb or less depending on vertical curve sight visibility restrictions). See County Road Standard 821.
- C. Shrubs and hedges shall be designed and planted the same as for parkways.
- D. Ground covers shall be designed and planted the same as for parkways.
- E. Lawns shall not be permitted in medians.

**24.5 WATER CONSERVATION AND IRRIGATION**

**24.5.1 Water Conservation**

- A. Landscapes installed in County rights-of-way and open space/common areas shall contain water conservation elements in both the planting and irrigation design.
- B. Mulch shall be used in planting areas as required herein.
- C. Plans shall conform to the requirements of the most recent version of Ordinance No. 859. Projected landscape water use shall be calculated using the water budget formula found in Ordinance No.859. Landscaping within the County Maintained Road rights-of-way shall be calculated at an ETo budget of 0.45 (or 45% ETo).
- D. Irrigation plans shall also conform to any requirements established by the local water purveyor servicing the project area.

**24.5.2 Irrigation System Design and Equipment**

- A. Irrigation design shall conform to the requirements of Ordinance No.859.X (X being latest County approved revision).
- B. Irrigation systems shall be designed according to maintenance areas. All irrigation system equipment (controllers, valves, piping, heads, etc.) shall be installed within the maintenance area. In landscape areas that include the right-of-way and a contiguous dedicated landscape easement, the irrigation system need not be separated if the entire

landscape area is being maintained by one entity. Areas maintained by different maintenance entities shall also have their own water and electrical points of connections (POC).

- C. Backflow prevention devices shall be covered with a vandal-resistant stainless steel or aluminum enclosure, powder-coated green (or tan in the Desert areas near DG), with locks.
- D. Irrigation systems, other than private individual homeowner areas, installed within road rights-of-way shall include the following:
  - 1. A wye filter or basket strainer shall be installed before backflow prevention devices (verify with local water entity). Backflow shall be painted 'Hunter Green' or Tan to deter theft (protect handles, serial numbers, and ports from paint).
  - 2. A Climate-Based smart controller (IA-SWAT tested) with access to real time EvapoTranspiration (ETo) rates shall have at least as many stations as valves indicated or per the irrigation design. Controller shall be solid state and equipped with multiple programs, water budgeting, and repeat cycles. Controller shall be enclosed in a vandal-resistant steel or aluminum enclosure.
  - 3. Irrigation systems shall be scheduled so the precipitation rate does not exceed the infiltration rate of the soil.
  - 4. Irrigation systems shall be equipped with a normally closed (NC) master valve and a flow sensor.
  - 5. Irrigation systems shall be equipped with a rain sensor which shall be located within an unobstructed natural rainfall area above the irrigation spray pattern.
  - 6. Gate valves shall be installed in pressure main lines at each valve along the system to allow shutting down portions of the system. Gate valves shall also be installed on the supply side of a main line that crosses a street.
  - 7. Remote control valves shall be installed below ground in valve boxes. Control valve wire shall be UGF wire, minimum 14 gauge. Common wire shall be UGF wire, WHITE, minimum of 12 gauge or larger. Wire shall be a continuous run from controller to valve for runs less than 2500 feet. Common wire splice shall occur at valve boxes or splice boxes. Two-wire systems shall be installed in conduit, minimum 1" size for a single two-wire cable. Conduit for wires shall be sleeved across hardscape and roadways for additional protection.
  - 8. Quick coupling valves (QCV) shall be located along pressure main line at maximum intervals of 25 feet. QCV shall be installed in a minimum 10" round valve box.
  - 9. Antidrain devices shall be installed where low head drainage may occur.
- E. High efficiency irrigation methods (for example drip, low volume rotators or rotors, micro-sprays, etc.) are encouraged.
- F. All spray heads and rotor heads shall be of the "pop-up" type with a minimum 6-inch pop up in turf areas and 12 inches in shrub areas. Medians shall be point source drip only.

- G. Where risers are necessary within the right of way, they shall be of flexible sch. 40 PVC pipe. Fixed/rigid risers are not permissible.
- H. Irrigation systems shall be designed to provide uniform coverage. The design for rotors and sprays shall be head-to-head coverage with a maximum of 60% diameter overlap. Irrigation system shall be designed to minimize and prevent spray on roadways and sidewalks.
- I. Pressure calculations shall be provided for valve with highest gpm and the farthest valve from point of connection. Slope system will require a pressure calculation for system with the greatest elevation increase.
- J. Pipe shall be sized to reduce pressure loss and as to not allow velocities to exceed 5 feet per second.
- K. If a pump is required, calculations shall be submitted for review.
- L. In areas designated to become part of the Landscaping & Lighting Maintenance District 89-1-Consolidated (L&LMD 89-1-C) or another Special District such as CFD or CSA, the County or District reserves the right to specify additional irrigation equipment that would reduce or minimize annual landscape operation costs Such features would be dependent upon the nature and extent of the proposed landscaping.

### **24.5.3 Installation**

- A. The landscape contractor shall coordinate the irrigation installation work, such as point of connections, sleeving, and utilities, with work of other trades. The irrigation installation shall be done in such a manner to avoid problems with the planting of trees and shrubs or other related work as called for on the Plans.
- B. Irrigation pressure mainlines shall be a minimum of 18 inches below finish grade. Non-pressure lateral lines shall be buried a minimum of 12 inches below finish grade. Where any pipes pass under vehicle access ways, the minimum pipe depth shall be 36 inches below finish surface and shall be installed in PVC sleeving including wire conduits.
- C. Valves and controllers shall be located in an accessible parkway or open space areas locations. Where and when possible, valves should be grouped together, utilizing a common shut-off device. Valves may be installed in medians, if necessary. Controllers shall not be placed in the median.
- D. Wiring for valves shall follow the mainline. Wiring shall be a minimum of 18 inches below finish grade. Where wiring passes under vehicle access ways, or the wiring does not follow the mainline, then the wiring shall be installed in a separate PVC conduit, minimum 1 inch size. A pull box shall be located at each end of the conduit. Two-wire systems shall be install in conduit, minimum 1" size for a single two-wire cable. Conduit for wires shall be sleeved across hardscape and roadways for additional protection.
- E. Provide an 18-inch-long expansion loop in wire run for each change in wiring direction and at valve boxes.
- F. Controller charts and reproducible as-built plans shall be provided to the County for all landscaping with the rights-of-way.

- G. Landscape architect of record shall certify that all landscaping and related irrigation was installed per plan and per these standards.

## **24.6 INSPECTION AND SUBMITTAL**

- 24.6.1 General:** All work within the County rights-of-way shall be subject to inspection to verify that work has been done according to approved Plans, County Road Standards, and per County Standard Specifications. The County Transportation Department shall be notified two working days prior to the work requiring inspection.

## **24.7 CONSTRUCTION CLEAN UP**

- 24.7.1 General:** During the course of the work, the sidewalks and street shall be left in an orderly, neat and clean condition. Equipment, supplies and materials shall be stored in a safe way and in a location so as not to interfere with other work or impair site distance. Excess equipment, material, soil, etc., shall be removed from the site.

## **24.8 STREET TREE MAINTENANCE, REMOVAL, PROTECTION, AND PRESERVATION**

### **24.8.1 Tree Maintenance**

- A. The Transportation Department provides street tree crews to perform limited tree trimming, when notified, where trees located within County rights-of-way have branches that overhang roadways or walkways and present a hazard to the traveling public, in accordance with County Resolution No. 73-142:

*TREES: Trees overhanging County roads, but whose trunks are off the County right-of-way, shall be the responsibility of the owner and made safe for traffic at their expense*

*Trees upon the County right-of-way shall be maintained by the County as to the safety and convenience of road travel. Their maintenance, or removal desired to benefit adjoining property, shall be at the expense of the adjoining property owner. Any work on trees situated on County right-of-way, performed by the adjoining property owners, shall be done under a permit issued by the Road Department (currently Transportation Department). (Resolution No. 73-142)*

Trees shall be pruned to meet the following criteria:

1. All branches overhanging roadways beyond curb face shall have 14'-0" minimum vertical clearance.
  2. All branches overhanging walkway shall be 8'-0" minimum vertical clearance.
  3. All branches overhanging trails shall be 10'-0" minimum vertical clearance.
- B. Trees covered by a landscape maintenance agreement or district shall be maintained or removed as necessary per the agreement or by the district.
- C. Utility pruning is a dangerous practice. Tree branches entangled in, or interfering with, overhead utility wires will be referred to the appropriate utility for maintenance requests.

- D. Tree Maintenance performed by County Contract, County Contractor, or hired by a private entity or individual shall be overseen by an International Society of Arboriculture (ISA) Certified Arborist. All tree work shall be completed in accordance with Approved American National Standard (ANSI) A300 and Z133 Standards, latest edition.
- E. Tree trimming operations shall be limited to those addressed within ANSI A300 and Z133 Standards, latest edition and line of sight issues. Tree Trimming for recreation purposes and commercial signage is not permitted, unless within a dedicated View Easement

#### **24.8.2 Tree Removal (On or Adjacent to County Road Rights-of-Way)**

The purpose of this standard is to establish a procedure to ensure that proper review is provided prior to the determination and ordering of work to remove trees from County maintained rights-of-way or trees located on private property which pose a public safety hazard to public-dedicated activities within County rights-of-way. Formerly Road and Survey Department Policy #26.

- A. Conditions upon which trees may be considered for removal:
  - 1. Dead or diseased.
  - 2. Danger to traffic or private property.
  - 3. Conflict with construction work or major maintenance project
  - 4. Trees creating unsafe conditions such as a sight distance restriction.
  - 5. Tree or trees located near the edge of the traveled way and are regarded as a target location of an errant vehicle.
  - 6. Removal is requested by adjacent property owners and justifiable by above stated conditions.
- B. The recommendation for such removal is to be submitted to the Deputy Director of Transportation for approval prior to commencing any removal activities. This report should provide, but is not limited to, the follow information:
  - 1. Road book map showing locations
  - 2. Accident data (at least three years).
  - 3. Contacts with the property owners.
- C. The Deputy Director of Transportation or Highway Operations Superintendent are authorized to approve such tree removal. However, any location where tree removal may be a sensitive issue in the neighborhood should be brought to the attention of the Director of Transportation who will in turn advise the County Supervisor for that Supervisorial District.
- D. The owner of trees on private property adjacent to County rights-of-way and whose trees have been designated for removal per the above shall be notified by the County to have the trees removed. Trees may be removed by the County, at the property owner's expense, if owner fails to comply with tree removal notice.
- E. Tree removals may require an ISA Certified Arborist Report outlining most of the following: existing tree characteristics, health, site conditions, target, defects, hazard rating, and abatement.

F. Tree removals shall follow the Migratory Bird Treaty Act.

### **24.8.3 Tree Protection During Construction**

Trees that have been targeted for preservation or are within the existing landscape (formal or informal), or adjacent to the County maintained right of way must be protected from any construction damage and/or construction activity around the tree. This should be kept in mind during the planning and/or permitting processes to ensure that the area around the tree is not planned to have utilities that would require trenching or otherwise affect the root zone, and that the area is not intended to be used as a staging area or even as a pass-through area where foot traffic or vehicular traffic will compact the soil.

- A. Each tree likely or near the construction area shall have a designated Tree Protection Zone (TPZ). Within this area is the Critical Root Zone (CRZ).
- B. Typically, a tree's dripline dictates the TPZ. On larger species, an estimated radius of 8-12 inches per every 1 inch of Diameter Breast Height (DBH) should be protected, depending on age and tolerance to construction damage.
- C. The TPZ shall be delineated or fenced prior to, during, and after construction operations.
- D. Construction activities which require access into the TPZ and/or CRZ or include root pruning for roots greater than 1" shall have a Tree Management Report outlining specifications for protecting said trees approved by the County.
- E. Construction activities shall minimize the following: root damage, trunk damage, soil compaction, irrigation interruption, reduction of crown by greater than 25%, exposure to the elements, grade changes.
- F. Tree Protection operations shall be limited to those addressed within ANSI A300 and Z133 Standards, latest edition.

### **24.8.4 Tree Preservation**

- A. Rapid population growth and vigorous development have resulted in the loss of a great number of trees throughout Riverside County. While new trees are being planted, the loss of specimen trees is an alarming situation. Therefore, a standard for tree preservation has been established to protect these precious resources as outlined below and also in the County Oak Tree Management Guidelines and Ordinance No. 559 pertaining to native trees above 5,000 feet in elevation.
- B. All tentative subdivision and parcel maps shall identify all trees located within proposed or existing road rights-of-way having a trunk diameter of 8 inches or more for trees 25 feet in height or greater. Trees shall be noted as to location, diameter, drip line extent, species name and common name. Trees of similar species and size which are part of a group or orchard need not be identified individually. Upon review by the Transportation Department staff, all trees identified as "specimen trees" shall be retained.
- C. Specimen trees are identified as being any tree which may possess historical value. Specimen trees shall be healthy and typical of species.

*Olea Europaea* (Olive), *Quercus agrifolia* (Coast Live Oak), *Populus fremontii* (Fremont's Cottonwood), *Plantanus racemosa* (Western Sycamore), *Salix lasiolepis* (Arroyo willow), *Salix gooddingii* (Black willow), *Salix laevigata* (Red willow), *Salix exigua* (Sandbar willow), and all Palm

species shall be retained whenever possible. When retention is not feasible, trees of these species shall be studied to be relocated.

# THE PRESS-ENTERPRISE

KEEP YOUR EYES ON THE 'PRISE

pe.com

3512 14 Street  
Riverside, California 92501  
(951) 368-9229  
neller@scng.com

County of Riverside - Clerk of the Board  
PO Box 1147  
Riverside, California 92502

<i>Account Number:</i>	5209148
<i>Ad Order Number:</i>	0011585013
<i>Customer's Reference/PO Number:</i>	
<i>Publication:</i>	The Press-Enterprise
<i>Publication Dates:</i>	02/07/2023
<i>Total Amount:</i>	\$294.62
<i>Payment Amount:</i>	\$0.00
<i>Amount Due:</i>	\$294.62
<i>Notice ID:</i>	aQBbsjdZLq1nmff4Fz41
<i>Invoice Text:</i>	BOARD OF SUPERVISORS OF THE COUNTY OF RIVERSIDE, STATE OF CALIFORNIA SUMMARY OF ORDINANCE NO. 461.11 AN ORDINANCE OF THE COUNTY OF RIVERSIDE AMENDING ORDINANCE NO.461 RELATING TO COUNTY ROAD STANDARDS AND COUNTY STANDARD SPECIFICATIONS This summary is presented pursuant to California Government Code Section 25124(b): a certified copy of the full text of Ordinance No. 461.11 may be examined at the Office of the Clerk of the Board of Supervisors of the County of Riverside, located at 4080 Lemon Street, 1st Floor, Riverside, California. In summary, Ordinance No. 461.11 amends Ordinance No. 461 in its entirety and replaces it with new language that adopts and amends the county road standards and specifications to establish proper standards, specifications, and directions for the design and construction of road improvements, or other land division improvements, required to be constructed in the unincorporated territory of the County of Riverside. These updates are necessary to ensure compliance with current applicable state and federal regulations, reflect advancements in technology, implement further public safety improvements, and clarify local requirements for the County road system. Ordinance No. 461.11 would take effect 30 days after its adoption. K. Jeffries, Chair of the Board I HEREBY CERTIFY that at a regular meeting of the Board of Supervisors of said County, held on January 31, 2023, the foregoing Ordinance was adopted by said Board by the following vote: AYES:Jeffries, Spiegel, Washington, Perez and GutierrezNAYS:NoneABSENT:None Kimberly Rector, Clerk of the Board By: Zuly Martinez, Board Assistant



# THE PRESS-ENTERPRISE

KEEP YOUR EYES ON **THE 'PRISE**

pe.com

The Press-Enterprise  
3512 14 Street  
Riverside, California 92501  
(951) 368-9229

County of Riverside - Clerk of the Board  
PO Box 1147  
Riverside, California 92502

Publication: The Press-Enterprise

PROOF OF PUBLICATION OF

Ad Desc: 0011585013

**FILE NO. 0011585013**

## PROOF OF PUBLICATION

I am a citizen of the United States. I am over the age of eighteen years and not party to or interested in the above-entitled matter. I am an authorized representative of THE PRESS-ENTERPRISE, a newspaper of general circulation, printed and published daily in the County of Riverside, and which newspaper has been adjudicated a newspaper of general circulation by the Superior Court of the County of Riverside, State of California, under date of April 25, 1952, Case Number 54446, under date of March 29, 1957, Case Number 65673, under date of August 25, 1995, Case Number 267864, and under date of September 16, 2013, Case Number RIC 1309013; that the notice, of which the annexed is a printed copy, has been published in said newspaper in accordance with the instructions of the person(s) requesting publication, and not in any supplement thereof on the following dates, to wit:

**02/07/2023**

I certify (or declare) under the penalty of perjury that the foregoing is true and correct.

Date: February 7, 2023.

At: Riverside, California



Signature

**SUMMARY OF ORDINANCE NO. 461.11**

**AN ORDINANCE OF THE COUNTY OF RIVERSIDE AMENDING ORDINANCE NO.461 RELATING TO COUNTY ROAD STANDARDS AND COUNTY STANDARD SPECIFICATIONS**

This summary is presented pursuant to California Government Code Section 25124(b) : a certified copy of the full text of Ordinance No. 461.11 may be examined at the Office of the Clerk of the Board of Supervisors of the County of Riverside, located at 4080 Lemon Street, 1st Floor, Riverside, California.

In summary, Ordinance No. 461.11 amends Ordinance No. 461 in its entirety and replaces it with new language that adopts and amends the county road standards and specifications to establish proper standards, specifications, and directions for the design and construction of road improvements, or other land division improvements, required to be constructed in the unincorporated territory of the County of Riverside. These updates are necessary to ensure compliance with current applicable state and federal regulations, reflect advancements in technology, implement further public safety improvements, and clarify local requirements for the County road system. Ordinance No. 461.11 would take effect 30 days after its adoption.

K. Jeffries, Chair of the Board

I HEREBY CERTIFY that at a regular meeting of the Board of Supervisors of said County, held on **January 31, 2023**, the foregoing Ordinance was adopted by said Board by the following vote:

AYES: Jeffries, Spiegel, Washington, Perez and Gutierrez  
NAYS: None  
ABSENT: None

Kimberly Rector, Clerk of the Board  
By: Zuly Martinez, Board Assistant  
**The Press-Enterprise**  
Published: 2/7/23