

SUBMITTAL TO THE BOARD OF SUPERVISORS  
COUNTY OF RIVERSIDE, STATE OF CALIFORNIA



ITEM: 3.37  
(ID # 22801)

MEETING DATE:  
Tuesday, September 12, 2023

FROM : TLMA-TRANSPORTATION:

SUBJECT: TRANSPORTATION AND LAND MANAGEMENT AGENCY/TRANSPORTATION:  
Approve Addendum to Plans and Specifications, Accept the Low Bid and Award the Contract for the Construction of the Johnston Avenue Resurfacing Project, in the Community of East Hemet; District 3. [\$2,938,000 Total Cost - Local Funds 100%]

RECOMMENDED MOTION: That the Board of Supervisors:

1. Approve one addendum to the plans and specifications issued prior to the July 5, 2023, bid opening;
2. Waive any and all immaterial irregularities and accept the low bid of Onyx Paving Company, Inc. (Onyx) of Anaheim, California in the amount of \$2,938,000;
3. Award the contract to Onyx and authorize the Chair of the Board to execute the contract documents; and
4. Approve the project proposed budget as shown on Attachment "A".

ACTION:Policy

  
Mark Lancaster, Director of Transportation 8/17/2023

---

MINUTES OF THE BOARD OF SUPERVISORS

On motion of Supervisor Washington, seconded by Supervisor Spiegel and duly carried by unanimous vote, IT WAS ORDERED that the above matter is approved as recommended.

Ayes: Jeffries, Spiegel, Perez, Washington, and Gutierrez  
Nays: None  
Absent: None  
Date: September 12, 2023  
xc: Trans.

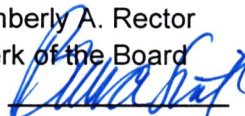
Kimberly A. Rector  
Clerk of the Board  
By:   
Deputy

**SUBMITTAL TO THE BOARD OF SUPERVISORS COUNTY OF RIVERSIDE,  
STATE OF CALIFORNIA**

<b>FINANCIAL DATA</b>	<b>Current Fiscal Year:</b>	<b>Next Fiscal Year:</b>	<b>Total Cost:</b>	<b>Ongoing Cost</b>
<b>COST</b>	\$ 2,938,000	\$ 0	\$ 2,938,000	\$ 0
<b>NET COUNTY COST</b>	\$ 0	\$ 0	\$ 0	\$ 0
<b>SOURCE OF FUNDS:</b> Gas Tax/SB-1 (99.8%) and Eastern Municipal Water District (0.2%). There are no General Funds used in this project.			<b>Budget Adjustment:</b> No	
			<b>For Fiscal Year:</b> 23/24	

**C.E.O. RECOMMENDATION:** Approve

**BACKGROUND:**

**Summary**

By Minute Order dated June 13, 2023 (Agenda Item 3.28), the County of Riverside Board of Supervisors authorized the Clerk of the Board to advertise for the construction of the Johnston Avenue Resurfacing Project. The limits on Johnston Avenue are from San Jacinto Street to 630-Foot East of Stanford Street in the community of East Hemet.

Johnston Avenue is a two-lane facility that travels in the East-West directions with a road width of 24 to 32 feet and is currently classified as a local road in the circulation element of the County of Riverside General Plan. The area in the immediate vicinity is residential with single family dwellings.

Roadway resurfacing is needed due to the deteriorated pavement conditions. Mainly, the resurfacing project will include one treatment type. The treatment consists of removing the existing asphalt concrete pavement and underlying material and placing back new Hot Mix Asphalt (HMA) pavement.

Additional improvements include reconstruction of sidewalk, curb and gutter, driveways, cross-gutter and spandrels, Americans with Disabilities Act (ADA) compliant curb ramps, safety features include placing of thermoplastic crosswalk and pavement marking, roadside signs, and other associated work.

During the advertisement period, one addendum was issued to all registered plan holders as a supplement to the plans and specifications. Bidders were required to acknowledge and take into account the issued addendum on their contractor's Bid in order to be considered for award.

The addendum was issued to clarify and make modifications to the plans and special provisions. The addendum is attached and designated as Addendum No. 1.

**SUBMITTAL TO THE BOARD OF SUPERVISORS COUNTY OF RIVERSIDE,  
STATE OF CALIFORNIA**

The Contract includes the following schedules of work:

Base Bid Schedule: Johnston Avenue Resurfacing  
Alternative Bid Schedule 1: Eastern Municipal Water District (EMWD) Manhole Adjustments

EMWD has accepted the bid prices proposed by Onyx for Alternative Bid Schedule 1 which includes adjustment to grade of five (5) manholes, and the cost for the work will be reimbursed by EMWD through reimbursement Agreement. The Director of Transportation has the authority to sign reimbursement Agreements up to \$100,000 per Minute Order dated November 19, 2019 (Agenda Item 3.25).

The contractor, Onyx, is qualified to perform the work as outlined in the bid, has executed the contract, and has provided bonds and insurance documents which meet the requirements of the contract documents.

Project No. B0-0612

**Impact on Residents and Businesses**

The purpose of this project is to replace existing deteriorated pavement with new hot mix asphalt for an approximate 1.7-mile segment of Johnston Avenue in the Community of East Hemet to provide the public with a smooth paved roadway that will improve the safety and efficiency of vehicular traffic.

The work is scheduled to begin in fall 2023. The work will be phased to keep the road open during construction as much as possible and will take approximately three months to complete.

**SUPPLEMENTAL:**

**Additional Fiscal Information**

Construction is expected to be completed in Fiscal Year 2023/2024 and will be funded with Gas Tax/SB-1 and EMWD funds.

The proposed budget as shown on Attachment "A" includes Contract award amount and other associated costs.

There are no General Funds used in this project.

**Contract History and Price Reasonableness**

A total of four bids were received on Wednesday July 5, 2023 ranging from \$2,938,000 to \$3,730,258. The basis for the selection of a contractor is the lowest responsive and responsible bid. The lowest responsive and responsible bid was submitted by Onyx in the amount of \$2,938,000 which is \$6,850 (0.2%) above the engineer's cost estimate.

**SUBMITTAL TO THE BOARD OF SUPERVISORS COUNTY OF RIVERSIDE,  
STATE OF CALIFORNIA**

The Transportation Department recommends the award of the contract to Onyx in the amount of \$2,938,000.

**ATTACHMENTS:**

Vicinity Map  
Attachment "A"  
Summary of Bids  
Addendum No. 1  
Contract/Bonds/Insurance  
Contractor's Bid Proposal

  
\_\_\_\_\_  
Jason Farin, Principal Management Analyst 9/6/2023

  
\_\_\_\_\_  
Kristine Bell-Valdez, Supervising Deputy County Counsel 9/5/2023

## Contract

THIS CONTRACT is entered into at Riverside, California as of the date set forth below is between County of Riverside hereafter called "County" and **Onyx Paving Company, Inc.**, hereafter called "Contractor".

### WITNESSETH

#### **Recitals:**

1. Contractor has submitted to County his Contractor's Proposal for the construction of County Project, **Johnston Avenue Resurfacing, San Jacinto Street to 630-Foot East of Stanford Street, Community of East Hemet, Project No. B0-0612**, in strict accordance with the Contract Documents identified below and County has accepted said Proposal.
2. Contractor states that he has reexamined his Contractor's Proposal and found it to be correct, has ascertained that his subcontractors are properly licensed and possess the requisite skill and forces, has reexamined the site and Contract Documents and is of the opinion that he can presently do the work in accordance with the Contract Documents for the money set forth in his Proposal to be paid as provided in the Contract Documents.

#### **Agreement:**

It is agreed by the parties as follows:

##### 1. Contract Documents

The entire Contract consists of the following: (a) The Construction Contract, (b) The Notice to Bidders, (c) The Instruction to Bidders, (d) The Bid, (e) The Bid Bond, (f) The Payment Bond, (g) The Performance Bond, (h) The General Conditions, (i) The Special Provisions, (j) The Standard Specifications of the State of California Department of Transportation edition of **2018** as modified in other portions of the Contract Documents and as amended by the State of California Department of Transportation, (k) The Standard Plans of the Department of Transportation identified on the plans or in the Special Provisions, (l) The Plans, (m) Addenda (**one**), (n) The Determination of Prevailing Wage Rates for Public Works, (o) Any Change Orders issued, and (p) Any additional or supplemental specifications, notice, instructions and drawings issued in accordance with the provisions of the Contract Documents. All of said Documents presently in existence are by this reference incorporated herein with like effect as if here set forth in full and upon the proper issuance of other documents they shall likewise be deemed incorporated. The Bid Bond is exonerated upon execution of this Contract and the Payment Bond and Performance Bond.

2. The Work

Contractor shall do all tasks necessary to construct the work generally described in Recital No. 1 in accordance with the Contract Documents.

3. Prosecution, Progress and Liquidated Damages

Attention is directed to the provisions in Section 8-1.04, "Start of Job Site Activities", Section 8-1.05, "Time", and in Section 8-1.10 "Liquidated Damages" of the Standard Specifications and these Special Provisions.

Standard Specification Section 8-1.04B, "Standard Start" is modified to read as follows:

The Contractor shall begin work within fifteen (15) calendar days, or as revised in the Special Provisions, of the date stated within the written "Notice to Proceed".

The Contractor shall notify the Engineer, in writing, of the Contractor's intent to begin work at least 72 hours before work is begun. If the project has more than one (1) location of work, Contractor shall submit a separate notice for each location. The notice shall be delivered to the Transportation Department's Construction Engineer and shall specify the date the Contractor intends to start at said location.

Should the Contractor begin work in advance of receiving a written "Notice to Proceed", any work performed by the Contractor in advance of the date stated in the "Notice to Proceed" shall be considered as having been done by the Contractor at his own risk and as a volunteer and subject to the following:

- A. The Contractor shall, on commencing operations, take all precautions required for public safety and shall observe all the provisions in the Specifications and the Special Provisions.
- B. All work done according to the Contract, prior to the issuance of the "Notice to Proceed", will be considered authorized work and will be paid for as provided in the contract.
- C. The Contractor shall not be entitled to any additional compensation or an extension of time for any delay, hindrance or interference caused by or attributable to commencement of work prior to the issuance of the "Notice to Proceed".

4. Compensation

Contractor shall be paid in the manner set forth in the Contract Documents the amount of his Proposal as accepted by County, the above rates, subject to additions and deductions as provided in the Contract Documents. Said Proposal is on file in the Office of the Clerk of the Board of Supervisors of County.

**Johnston Avenue Resurfacing  
San Jacinto Street to 630-Foot East of Stanford Street  
Community of East Hemet  
Project No. B0-0612**

**Contract**

ITEM No.	ITEM CODE	ITEM	UNIT	ESTIMATED QUANTITY	ITEM PRICE (IN FIGURES)	TOTAL (IN FIGURES)
<b>BASE BID SCHEDULE - Johnston Avenue Resurfacing</b>						
1	100100	DEVELOP WATER SUPPLY	LS	1	11,602.00	11,602.00
2	120100	TRAFFIC CONTROL SYSTEM	LS	1	222,000.00	222,000.00
3	130200	PREPARE WATER POLLUTION CONTROL PROGRAM	LS	1	11,000.00	11,000.00
4	170103	CLEARING AND GRUBBING	LS	1	333,000.00	333,000.00
5	066100	DUST ABATEMENT	LS	1	11,000.00	11,000.00
6	190101(F)	ROADWAY EXCAVATION	CY	5,300	55.00	291,500.00
7	013903	PLACE ASPHALT CONCRETE DIKE (CRS 212) (6")	LF	95	11.00	1,045.00
8	013904	PLACE ASPHALT CONCRETE DIKE (CRS 212) (8")	LF	95	11.00	1,045.00
9	394075	PLACE HOT MIX ASPHALT DIKE (TYPE D) [PER CALTRANS STD A87B]	LF	1,900	11.00	20,900.00
10	394075	PLACE HOT MIX ASPHALT DIKE (TYPE D) [PER CALTRANS STD A87B, MODIFIED TO 8" HEIGHT]	LF	550	11.00	6,050.00
11	394076	PLACE HOT MIX ASPHALT DIKE (TYPE E) (PER CALTRANS STD. A87B)	LF	30	11.00	330.00
12	390132	HOT MIX ASPHALT (TYPE A)	TON	11,500	111.00	1,276,500.00
13	013905	ASPHALT CONCRETE (DRIVEWAY APPROACH WITH ASPHALT CONCRETE DIKE) (CRS 206)	SQFT	180	10.00	1,800.00
14	013905	ASPHALT CONCRETE (DRIVEWAY APPROACH WITH ASPHALT CONCRETE DIKE) (CRS 206) [MODIFIED FOR MOUNTABLE DIKE]	SQFT	6,600	6.00	39,600.00
15	013908	ASPHALT CONCRETE DRIVEWAY [3.5-INCH ON NATIVE]	SQFT	18,000	5.00	90,000.00
16	710220	ADJUST UTILITY COVER TO GRADE [WATER METER, LHMWD]	EA	15	2,000.00	30,000.00

**Contract (Continued)**

ITEM No.	ITEM CODE	ITEM	UNIT	ESTIMATED QUANTITY	ITEM PRICE (IN FIGURES)	TOTAL (IN FIGURES)
<b>BASE BID SCHEDULE - Johnston Avenue Resurfacing (Continued)</b>						
17	710200	ADJUST MANHOLE [LHMWD]	EA	24	1,500.00	36,000.00
18	710192	ADJUST SEWER CLEANOUT TO GRADE [LHMWD]	EA	2	1,500.00	3,000.00
19	731516	MINOR CONCRETE (DRIVEWAY) [CRS 213]	SQFT	160	20.00	3,200.00
20	731516	MINOR CONCRETE (DRIVEWAY) [MODIFIED FOR MOUNTABLE DIKE]	SQFT	1,400	20.00	28,000.00
21	731516	MINOR CONCRETE (DRIVEWAY) [6-INCH ON NATIVE]	SQFT	950	20.00	19,000.00
22	017301	MINOR CONCRETE (DRIVEWAY APPROACH WITH ASPHALT CONCRETE DIKE) (CRS 206) [MODIFIED FOR CURB AND GUTTER]	SQFT	550	20.00	11,000.00
23	017304	MINOR CONCRETE (CURB AND GUTTER) (CRS 200)	LF	420	69.00	28,980.00
24	017315	MINOR CONCRETE (CURB RAMP) (CRS 403 - CASE A)	EA	4	8,400.00	33,600.00
25	017316	MINOR CONCRETE (CURB RAMP) (CRS 403 - CASE B) [MODIFIED PER PLAN]	EA	2	8,400.00	16,800.00
26	017317	MINOR CONCRETE (CROSS-GUTTER AND SPANDREL) (CRS 209)	SQFT	4,100	27.00	110,700.00
27	510502	MINOR CONCRETE (MINOR STRUCTURE) [CRS 308, MODIFIED FOR REVERSE FLOW INLET, WIDTH = 4']	EA	1	27,000.00	27,000.00
28	011503	UNDER SIDEWALK DRAIN CAST IN PLACE (CRS 309)	EA	1	16,880.00	16,880.00
29	731507	MINOR CONCRETE (GUTTER DEPRESSION)	EA	1	9,000.00	9,000.00
30	731521	MINOR CONCRETE (SIDEWALK) [AND 4' WALKWAYS]	SQFT	670	13.00	8,710.00
31	782110	RESET MAILBOX [OR RELOCATE MAILBOX]	EA	15	400.00	6,000.00
32	810230(F)	PAVEMENT MARKER (RETROREFLECTIVE)	EA	310	11.00	3,410.00
33	820250	REMOVE ROADSIDE SIGN [AND SALVAGE]	EA	22	111.00	2,442.00
34	820840	ROADSIDE SIGN - ONE POST	EA	22	373.00	8,206.00
35	840656(F)	PAINT TRAFFIC STRIPE (2-COAT)	LF	14,500	0.55	7,975.00



**Contract (Continued)**

ITEM No.	ITEM CODE	ITEM	UNIT	ESTIMATED QUANTITY	ITEM PRICE (IN FIGURES)	TOTAL (IN FIGURES)
----------	-----------	------	------	--------------------	-------------------------	--------------------

**BASE BID SCHEDULE - Johnston Avenue Resurfacing (Continued)**

36	840519	THERMOPLASTIC CROSSWALK AND PAVEMENT MARKING	SQFT	675	7.00	4,725.00
37	010602	MISCELLANEOUS WORK (AS DIRECTED)	FA	1	200,000.00	200,000.00

BASE BID SCHEDULE: \_\_\_\_\_ Two million, nine hundred thirty-two thousand dollars and zero cents **\$2,932,000.00**  
 ITEMS 1 - 37 "WORDS"

**ALTERNATIVE BID SCHEDULE 1 - EMWD Manhole Adjustments**

38	710200	ADJUST MANHOLE [EMWD]	EA	5	1,200.00	6,000.00
----	--------	-----------------------	----	---	----------	----------

ALT. BID SCHEDULE 1: \_\_\_\_\_ Six thousand dollars and zero cents **\$6,000.00**  
 ITEM 38 "WORDS"

**PROJECT TOTAL:** \_\_\_\_\_ **Two million, nine hundred thirty-eight thousand dollars and zero cents** **\$2,938,000.00**  
 ITEMS 1 - 38 "WORDS"

**Johnston Avenue Resurfacing  
San Jacinto Street to 630-Foot East of Stanford Street  
Community of East Hemet  
Project No. B0-0612**

IN WITNESS WHEREOF the parties hereto have executed this Contract as of the date set forth below.

**COUNTY OF RIVERSIDE**

**ONYX PAVING COMPANY, INC.**

BY:   
**KEVIN JEFFRIES**  
Chair, Board of Supervisors

BY: 

DATED: 9/12/23

TITLE: Corey Kirschner - President  
(If Corporation, affix Seal)

ATTEST:  
Kimberly A. Rector, Clerk of the Board

ATTEST: 

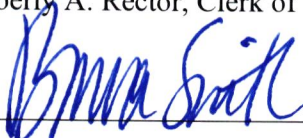
BY:   
Deputy

TITLE: Corey Kirschner - Secretary

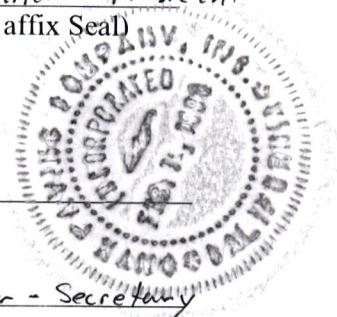

Licensed in accordance with an act providing for the registration of Contractors,

License No.: 630360

Federal Employer Identification Number:  
33-0394344

Department of Industrial Relations Registration Number:  
1000004798

FORM APPROVED COUNTY COUNSEL  
BY:   
DANIELLE D. MALAND

BY \_\_\_\_\_  
"County"

\_\_\_\_\_  
"Corporation"  
(Seal)

**CALIFORNIA ALL-PURPOSE ACKNOWLEDGMENT**

**CIVIL CODE § 1189**

A notary public or other officer completing this certificate verifies only the identity of the individual who signed the document to which this certificate is attached, and not the truthfulness, accuracy, or validity of that document.

State of California )

County of Orange )

On July 20, 2023 before me, Carly Bredal, Notary Public,  
*Date Here Insert Name and Title of the Officer*

personally appeared Corey R. Kirschner  
*Name(s) of Signer(s)*

who proved to me on the basis of satisfactory evidence to be the person(s) whose name(s) is/are subscribed to the within instrument and acknowledged to me that he/she/they executed the same in his/her/their authorized capacity(ies), and that by his/her/their signature(s) on the instrument the person(s), or the entity upon behalf of which the person(s) acted, executed the instrument.

I certify under PENALTY OF PERJURY under the laws of the State of California that the foregoing paragraph is true and correct.

WITNESS my hand and official seal.

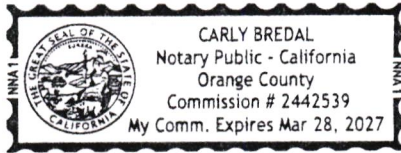

Signature *Carly Bredal*  
*Signature of Notary Public*

*Place Notary Seal Above*

**OPTIONAL**

*Though this section is optional, completing this information can deter alteration of the document or fraudulent reattachment of this form to an unintended document.*

**Description of Attached Document**

Title or Type of Document: \_\_\_\_\_ Document Date: \_\_\_\_\_  
Number of Pages: \_\_\_\_\_ Signer(s) Other Than Named Above: \_\_\_\_\_

**Capacity(ies) Claimed by Signer(s)**

Signer's Name: \_\_\_\_\_  
 Corporate Officer — Title(s): \_\_\_\_\_  
 Partner —  Limited  General  
 Individual  Attorney in Fact  
 Trustee  Guardian or Conservator  
 Other: \_\_\_\_\_  
Signer Is Representing: \_\_\_\_\_

Signer's Name: \_\_\_\_\_  
 Corporate Officer — Title(s): \_\_\_\_\_  
 Partner —  Limited  General  
 Individual  Attorney in Fact  
 Trustee  Guardian or Conservator  
 Other: \_\_\_\_\_  
Signer Is Representing: \_\_\_\_\_



**ONYX PAVING COMPANY INC**  
LICENSE # 630360 DIR # 1000004798

**UNANIMOUS WRITTEN CONSENT OF  
THE BOARD OF DIRECTORS OF  
ONYX PAVING COMPANY, INC,  
(a California corporation)**

June 17<sup>th</sup>, 2022

The undersigned director, constituting the entire board of directors (the "Board") of Onyx Paving Company, Inc., a California corporation (the "Corporation"), hereby takes the following actions, adopts the following resolutions, and transacts the following business, by written consent without a meeting, as of the date above written, pursuant to Section 307(b) of the General Corporation Law of the State of California and the Corporations Bylaws:

**Approval of Loan Transactions**

**WHEREAS**, Corey Kirschner is currently the Corporation's Chief Executive Officer, Chief Financial Officer (the "Officer") and Secretary with authority to enter into contracts on behalf of the Corporation.

**WHEREAS**, the Corporation opportunities from time to time to bid on various governmental and non-governmental projects;

**WHEREAS**, after careful consideration, the Board has determined that the terms and conditions of the proposed project in the form of the bid attached hereto as Exhibit A (the "Project") are just and equitable and fair as to the Corporation and that it is in the best interests of the Corporation and its stockholder to submit the bid and complete the Project subject to the terms agreed upon by the parties.

**NOW, THEREFORE, BE IT RESOLVED**, the Board on behalf of the Corporation hereby approves and ratifies the Project in all respects, and hereby authorize and direct the Corporation to negotiate, execute, deliver and perform the terms of all documents, required in connection with title Project, together with such changes thereto as may be approved by the Officer executing the same on behalf of the Corporation (pursuant to the authorization provided herein), such approval of the Officer to be conclusively evidenced by its execution and delivery of same.

**RESOLVED FURTHER**, that the Officer may execute and deliver any and all agreements and any and all other documents and instruments, and take such further actions as may be necessary or appropriate, for the financing of the Corporation.

**RESOLVED FURTHER**, that the Officer is hereby authorized, directed, and empowered to execute and deliver any and all agreements and any and all other documents and instruments, and take such further actions as may be necessary or appropriate, for the consummation of the Project.

**RESOLVED FURTHER**, that the Officer, in the name of the Corporation, is hereby authorized, directed, and empowered to negotiate, execute and deliver to the applicable counterparty, any and all documents with respect to the Project and other instruments as may be reasonably requested, and the Officer on behalf of the Corporation is authorized from time to time to execute extensions or other installments as may be necessary.

**RESOLVED FURTHER**, that the authority given hereunder shall be deemed retroactive and any and all acts authorized hereunder performed prior to the passage of this resolution are hereby ratified and affirmed.

The Secretary of the Corporation is directed to file the original executed copy of this Consent with the minutes of proceedings of the Corporation.

**[Signature page follows]**



**ONYX PAVING COMPANY INC**  
LICENSE # 630360 DIR # 1000004798

**IN WITNESS WHEREOF**, the undersigned has executed this Unanimous Written Consent of the Board of Directors as of the date first above written

---

Corey Kirschner

### Performance Bond

**Recitals:**

1. **Onyx Paving Company, Inc.** (Contractor) has entered into a Contract with COUNTY OF RIVERSIDE (County) for construction of public work known as **Johnston Avenue Resurfacing, San Jacinto Street to 630-Foot East of Stanford Street, Community of East Hemet, Project No. B0-0612.**
2. United Fire & Casualty Company \_\_\_\_\_, a Iowa \_\_\_\_\_ corporation (Surety), is the Surety under this Bond.

**Agreement:**

We, Contractor as Principal and Surety as Surety, jointly and severally agree, state, and are bound unto County, as obligee, as follows:

1. The amount of the obligation of this Bond is 100% of the estimated contract price for the Project of **\$2,938,000.00 (Two million, nine hundred thirty-eight thousand dollars and zero cents)** and inures to the benefit of County.
2. This Bond is exonerated by Contractor doing all things to be kept and performed by it in strict conformance with the Contract Documents for this project, otherwise it remains in full force and effect for the recovery of loss, damage and expense of County resulting from failure of Contractor to so act. All of said Contract Documents are incorporated herein.
3. This obligation is binding on our successors and assigns.
4. For value received, Surety stipulates and agrees that no change, time extension, prepayment to Contractor, alteration or addition to the terms and requirements of the Contract Documents or the work to be performed thereunder shall affect its obligations hereunder and waives notice as to such matters, except the total contract price cannot be increased by more than 10% without approval of Surety.

THIS BOND is executed as of July 17th, 2023 \_\_\_\_\_

By Onyx Paving Company, Inc. \_\_\_\_\_

By \_\_\_\_\_  
United Fire & Casualty Company

By \_\_\_\_\_

Type Name Albert Melendez \_\_\_\_\_

Title Corey Kirschner - President

Its Attorney in Fact  
"Surety"

"Contractor"

(Corporate Seal)

(Corporate Seal)



**NOTE: This Bond must be executed by both parties with corporate seal affixed. All signatures must be acknowledged.** (Attach acknowledgements).

**CALIFORNIA ALL-PURPOSE ACKNOWLEDGMENT**

**CIVIL CODE § 1189**

A notary public or other officer completing this certificate verifies only the identity of the individual who signed the document to which this certificate is attached, and not the truthfulness, accuracy, or validity of that document.

State of California )

County of Orange )

On July 17, 2023 before me, Carly Bredal, Notary Public,  
*Date Here Insert Name and Title of the Officer*

personally appeared Corey R. Kirschner  
*Name(s) of Signer(s)*

who proved to me on the basis of satisfactory evidence to be the person(s) whose name(s) is/are subscribed to the within instrument and acknowledged to me that he/she/they executed the same in his/her/their authorized capacity(ies), and that by his/her/their signature(s) on the instrument the person(s), or the entity upon behalf of which the person(s) acted, executed the instrument.

I certify under PENALTY OF PERJURY under the laws of the State of California that the foregoing paragraph is true and correct.

WITNESS my hand and official seal.



Signature Carly Bredal  
*Signature of Notary Public*

*Place Notary Seal Above*

**OPTIONAL**

*Though this section is optional, completing this information can deter alteration of the document or fraudulent reattachment of this form to an unintended document.*

**Description of Attached Document**

Title or Type of Document: \_\_\_\_\_ Document Date: \_\_\_\_\_

Number of Pages: \_\_\_\_\_ Signer(s) Other Than Named Above: \_\_\_\_\_

**Capacity(ies) Claimed by Signer(s)**

Signer's Name: \_\_\_\_\_

Corporate Officer — Title(s): \_\_\_\_\_

Partner —  Limited  General

Individual  Attorney in Fact

Trustee  Guardian or Conservator

Other: \_\_\_\_\_

Signer Is Representing: \_\_\_\_\_

Signer's Name: \_\_\_\_\_

Corporate Officer — Title(s): \_\_\_\_\_

Partner —  Limited  General

Individual  Attorney in Fact

Trustee  Guardian or Conservator

Other: \_\_\_\_\_

Signer Is Representing: \_\_\_\_\_



**CALIFORNIA ALL-PURPOSE ACKNOWLEDGMENT**

**CIVIL CODE § 1189**

A notary public or other officer completing this certificate verifies only the identity of the individual who signed the document to which this certificate is attached, and not the truthfulness, accuracy, or validity of that document.

State of California )  
County of Orange )

On JUL 17 2023 before me, Melissa A. Lopez, Notary Public  
*Date Here Insert Name and Title of the Officer*

personally appeared Albert Melendez  
*Name(s) of Signer(s)*

who proved to me on the basis of satisfactory evidence to be the person(s) whose name(s) is/~~are~~ subscribed to the within instrument and acknowledged to me that he/~~she/they~~ executed the same in his/~~her/their~~ authorized capacity(ies), and that by his/~~her/their~~ signature(s) on the instrument the person(s), or the entity upon behalf of which the person(s) acted, executed the instrument.

I certify under PENALTY OF PERJURY under the laws of the State of California that the foregoing paragraph is true and correct.

WITNESS my hand and official seal.

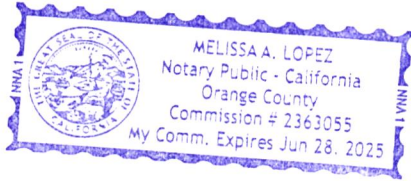

Signature *Melissa Lopez*  
*Signature of Notary Public*

*Place Notary Seal Above*

**OPTIONAL**

*Though this section is optional, completing this information can deter alteration of the document or fraudulent reattachment of this form to an unintended document.*

**Description of Attached Document**

Title or Type of Document: \_\_\_\_\_ Document Date: \_\_\_\_\_

Number of Pages: \_\_\_\_\_ Signer(s) Other Than Named Above: \_\_\_\_\_

**Capacity(ies) Claimed by Signer(s)**

Signer's Name: \_\_\_\_\_

- Corporate Officer — Title(s): \_\_\_\_\_
- Partner —  Limited  General
- Individual  Attorney in Fact
- Trustee  Guardian or Conservator
- Other: \_\_\_\_\_

Signer Is Representing: \_\_\_\_\_

Signer's Name: \_\_\_\_\_

- Corporate Officer — Title(s): \_\_\_\_\_
- Partner —  Limited  General
- Individual  Attorney in Fact
- Trustee  Guardian or Conservator
- Other: \_\_\_\_\_

Signer Is Representing: \_\_\_\_\_



UNITED FIRE & CASUALTY COMPANY, CEDAR RAPIDS, IA  
 UNITED FIRE & INDEMNITY COMPANY, WEBSTER, TX  
 FINANCIAL PACIFIC INSURANCE COMPANY, LOS ANGELES, CA  
 CERTIFIED COPY OF POWER OF ATTORNEY  
 (original on file at Home Office of Company – See Certification)

Inquiries: Surety Department  
 118 Second Ave SE  
 Cedar Rapids, IA 52401

KNOW ALL PERSONS BY THESE PRESENTS, That United Fire & Casualty Company, a corporation duly organized and existing under the laws of the State of Iowa; United Fire & Indemnity Company, a corporation duly organized and existing under the laws of the State of Texas; and Financial Pacific Insurance Company, a corporation duly organized and existing under the laws of the State of California (herein collectively called the Companies), and having their corporate headquarters in Cedar Rapids, State of Iowa, does make, constitute and appoint

ERIK JOHANSSON, JOAQUIN PEREZ, ALBERT MELENDEZ, JENNIFER ANAYA, MELISSA LOPEZ, CHRISTINA ROGERS,  
 EACH INDIVIDUALLY

their true and lawful Attorney(s)-in-Fact with power and authority hereby conferred to sign, seal and execute in its behalf all lawful bonds, undertakings and other obligatory instruments of similar nature provided that no single obligation shall exceed \$25,000,000.00 and to bind the Companies thereby as fully and to the same extent as if such instruments were signed by the duly authorized officers of the Companies and all of the acts of said Attorney, pursuant to the authority hereby given and hereby ratified and confirmed.

The Authority hereby granted shall expire the 24th day of August, 2024 unless sooner revoked by United Fire & Casualty Company, United Fire & Indemnity Company, and Financial Pacific Insurance Company.

This Power of Attorney is made and executed pursuant to and by authority of the following bylaw duly adopted by the Boards of Directors of United Fire & Casualty Company, United Fire & Indemnity Company, and Financial Pacific Insurance Company.

**“Article VI – Surety Bonds and Undertakings”**

Section 2, Appointment of Attorney-in-Fact. “The President or any Vice President, or any other officer of the Companies may, from time to time, appoint by written certificates attorneys-in-fact to act in behalf of the Companies in the execution of policies of insurance, bonds, undertakings and other obligatory instruments of like nature. The signature of any officer authorized hereby, and the Corporate seal, may be affixed by facsimile to any power of attorney or special power of attorney or certification of either authorized hereby; such signature and seal, when so used, being adopted by the Companies as the original signature of such officer and the original seal of the Companies, to be valid and binding upon the Companies with the same force and effect as though manually affixed. Such attorneys-in-fact, subject to the limitations set of forth in their respective certificates of authority shall have full power to bind the Companies by their signature and execution of any such instruments and to attach the seal the Companies thereto. The President or any Vice President, the Board of Directors or any other officer of the Companies may at any time revoke all power and authority previously given to any attorney-in-fact.

IN WITNESS WHEREOF, the COMPANIES have each caused these presents to be signed by its vice president and its corporate seal to be hereto affixed this 24th day of August, 2022



UNITED FIRE & CASUALTY COMPANY  
 UNITED FIRE & INDEMNITY COMPANY  
 FINANCIAL PACIFIC INSURANCE COMPANY

By: *Dennis J. Richmann*  
 Vice President

State of Iowa, County of Linn, ss:

On 24th day of August, 2022, before me personally came Dennis J. Richmann to me known, who being by me duly sworn, did depose and say; that he resides in Cedar Rapids, State of Iowa; that he is a Vice President of United Fire & Casualty Company, a Vice President of United Fire & Indemnity Company, and a Vice President of Financial Pacific Insurance Company the corporations described in and which executed the above instrument; that he knows the seal of said corporations; that the seal affixed to the said instrument is such corporate seal; that it was so affixed pursuant to authority given by the Board of Directors of said corporations and that he signed his name thereto pursuant to like authority, and acknowledges same to be the act and deed of said corporations.



*Judith A. Jones*  
 Notary Public  
 My commission expires: 4/23/2024

I, Mary A. Bertsch, Assistant Secretary of United Fire & Casualty Company and Assistant Secretary of United Fire & Indemnity Company, and Assistant Secretary of Financial Pacific Insurance Company, do hereby certify that I have compared the foregoing copy of the Power of Attorney and affidavit, and the copy of the Section of the bylaws and resolutions of said Corporations as set forth in said Power of Attorney, with the ORIGINALS ON FILE IN THE HOME OFFICE OF SAID CORPORATIONS, and that the same are correct transcripts thereof, and of the whole of the said originals, and that the said Power of Attorney has not been revoked and is now in full force and effect.

In testimony whereof I have hereunto subscribed my name and affixed the corporate seal of the said Corporations this 17th day of July, 2023.



By: *Mary A. Bertsch*  
 Assistant Secretary,  
 UF&C & UF&I & FPIC



United Fire & Casualty Company  
United Fire & Indemnity Company  
Financial Pacific Insurance Company

SURETY

## SURETY BOND SEAL ADDENDUM

United Fire & Casualty Company  
PO Box 73909  
Cedar Rapids, Iowa 52407

United Fire & Casualty Company has authorized its Attorneys-in-Fact to affix United Fire & Casualty Company corporate seal to any bond executed on behalf of United Fire & Casualty Company by any such Attorney-in-Fact by attaching this Addendum to said bond.

To the extent this Addendum is attached to a bond that is executed on behalf of United Fire & Casualty Company by its Attorney-in-Fact, United Fire & Casualty Company hereby agrees that the seal below shall be deemed affixed to said bond to the same extent as if its raised corporate seal was physically affixed to the face of the bond.

Dated this 17th day of July, 2023.

United Fire & Casualty Company

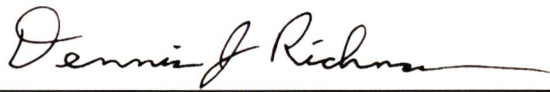

By:   
Dennis J. Richmann, Vice President

**Payment Bond**

(Public Works - Civil Code §9550 et seq.)

The makers of this Bond are **Onyx Paving Company, Inc.** as Principal and Original Contractor and United Fire & Casualty Company, a corporation, authorized to issue Surety Bonds in California, as Surety, and this Bond is issued in conjunction with that certain public works contract to be executed between Principal and COUNTY OF RIVERSIDE a public entity, as Owner, for **\$2,938,000.00 (Two million, nine hundred thirty-eight thousand dollars and zero cents)** the total amount payable. The amount of this bond is one hundred percent (100%) of said sum. Said contract is for public work generally consisting of **Johnston Avenue Resurfacing, San Jacinto Street to 630-Foot East of Stanford Street, Community of East Hemet, Project No. B0-0612.**

The beneficiaries of this Bond are as is stated in 9554 of the Civil Code and requirements and conditions of this Bond are as is set forth in 9554, 9558, 9560 and 9564 of said code. Without notice, Surety consents to extension of time for performance, change in requirements, amount of compensation, or prepayment under said contract.

Dated: July 17th, 2023

Onyx Paving Company, Inc.  
Original Contractor – Principal

United Fire & Casualty Company  
Surety

By [Signature]

By [Signature]

Title Corey Kirschner - President

Albert Melendez, Its Attorney In Fact

(If corporation, affix seal)

(Corporate Seal)

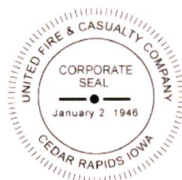

(Corporate Seal)

STATE \_\_\_\_\_  
OF \_\_\_\_\_  
COUNTY \_\_\_\_\_  
OF \_\_\_\_\_

} ss. SURETY'S ACKNOWLEDGEMENT

On \_\_\_\_\_ before me, \_\_\_\_\_ personally appeared, \_\_\_\_\_, known to me, or proved to me on the basis of satisfactory evidence, to be the person whose name is subscribed to the within instrument and acknowledged to me that he executed the same in his authorized capacities, and that by his signature on the instrument the person, or the entity upon behalf of which the person acted, executed the instrument.

WITNESS my hand and official seal.

\_\_\_\_\_  
Signature of Notary Public

Notary Public (Seal)

**NOTE: This Bond must be executed by both parties with corporate seal affixed. All signatures must be acknowledged.** (Attach acknowledgements).

**CALIFORNIA ALL-PURPOSE ACKNOWLEDGMENT**

**CIVIL CODE § 1189**

A notary public or other officer completing this certificate verifies only the identity of the individual who signed the document to which this certificate is attached, and not the truthfulness, accuracy, or validity of that document.

State of California )  
County of Orange )

On July 17, 2023 before me, Carly Bredal, Notary Public,  
*Date Here Insert Name and Title of the Officer*

personally appeared Corey R. Kirschner  
*Name(s) of Signer(s)*

who proved to me on the basis of satisfactory evidence to be the person(x) whose name(x) is/~~are~~ subscribed to the within instrument and acknowledged to me that he/~~she~~/~~they~~ executed the same in his/~~her~~/~~their~~ authorized capacity(ies), and that by his/~~her~~/~~their~~ signature(x) on the instrument the person(x), or the entity upon behalf of which the person(x) acted, executed the instrument.

I certify under PENALTY OF PERJURY under the laws of the State of California that the foregoing paragraph is true and correct.

WITNESS my hand and official seal.



Signature Carly Bredal  
*Signature of Notary Public*

Place Notary Seal Above

**OPTIONAL**

Though this section is optional, completing this information can deter alteration of the document or fraudulent reattachment of this form to an unintended document.

**Description of Attached Document**

Title or Type of Document: \_\_\_\_\_ Document Date: \_\_\_\_\_  
Number of Pages: \_\_\_\_\_ Signer(s) Other Than Named Above: \_\_\_\_\_

**Capacity(ies) Claimed by Signer(s)**

Signer's Name: \_\_\_\_\_  
 Corporate Officer — Title(s): \_\_\_\_\_  
 Partner —  Limited  General  
 Individual  Attorney in Fact  
 Trustee  Guardian or Conservator  
 Other: \_\_\_\_\_  
Signer Is Representing: \_\_\_\_\_

Signer's Name: \_\_\_\_\_  
 Corporate Officer — Title(s): \_\_\_\_\_  
 Partner —  Limited  General  
 Individual  Attorney in Fact  
 Trustee  Guardian or Conservator  
 Other: \_\_\_\_\_  
Signer Is Representing: \_\_\_\_\_

**CALIFORNIA ALL-PURPOSE ACKNOWLEDGMENT**

**CIVIL CODE § 1189**

A notary public or other officer completing this certificate verifies only the identity of the individual who signed the document to which this certificate is attached, and not the truthfulness, accuracy, or validity of that document.

State of California )  
County of Orange )  
On JUL 17 2023 before me, Melissa A. Lopez, Notary Public  
Date Here Insert Name and Title of the Officer  
personally appeared Albert Melendez  
Name(s) of Signer(s)

who proved to me on the basis of satisfactory evidence to be the person(s) whose name(s) is/are subscribed to the within instrument and acknowledged to me that he/~~she/they~~ executed the same in his/~~her/their~~ authorized capacity(ies), and that by his/~~her/their~~ signature(s) on the instrument the person(s), or the entity upon behalf of which the person(s) acted, executed the instrument.

I certify under PENALTY OF PERJURY under the laws of the State of California that the foregoing paragraph is true and correct.

WITNESS my hand and official seal.

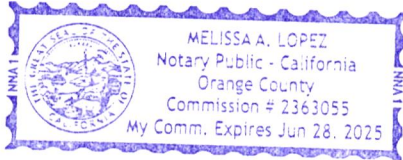

Signature [Handwritten Signature]  
Signature of Notary Public

Place Notary Seal Above

**OPTIONAL**

Though this section is optional, completing this information can deter alteration of the document or fraudulent reattachment of this form to an unintended document.

**Description of Attached Document**

Title or Type of Document: \_\_\_\_\_ Document Date: \_\_\_\_\_

Number of Pages: \_\_\_\_\_ Signer(s) Other Than Named Above: \_\_\_\_\_

**Capacity(ies) Claimed by Signer(s)**

Signer's Name: \_\_\_\_\_

Corporate Officer — Title(s): \_\_\_\_\_

Partner —  Limited  General

Individual  Attorney in Fact

Trustee  Guardian or Conservator

Other: \_\_\_\_\_

Signer Is Representing: \_\_\_\_\_

Signer's Name: \_\_\_\_\_

Corporate Officer — Title(s): \_\_\_\_\_

Partner —  Limited  General

Individual  Attorney in Fact

Trustee  Guardian or Conservator

Other: \_\_\_\_\_

Signer Is Representing: \_\_\_\_\_



UNITED FIRE & CASUALTY COMPANY, CEDAR RAPIDS, IA  
 UNITED FIRE & INDEMNITY COMPANY, WEBSTER, TX  
 FINANCIAL PACIFIC INSURANCE COMPANY, LOS ANGELES, CA  
 CERTIFIED COPY OF POWER OF ATTORNEY  
 (original on file at Home Office of Company – See Certification)

Inquiries: Surety Department  
 118 Second Ave SE  
 Cedar Rapids, IA 52401

KNOW ALL PERSONS BY THESE PRESENTS, That United Fire & Casualty Company, a corporation duly organized and existing under the laws of the State of Iowa; United Fire & Indemnity Company, a corporation duly organized and existing under the laws of the State of Texas; and Financial Pacific Insurance Company, a corporation duly organized and existing under the laws of the State of California (herein collectively called the Companies), and having their corporate headquarters in Cedar Rapids, State of Iowa, does make, constitute and appoint

ERIK JOHANSSON, JOAQUIN PEREZ, ALBERT MELENDEZ, JENNIFER ANAYA, MELISSA LOPEZ, CHRISTINA ROGERS,  
 EACH INDIVIDUALLY

their true and lawful Attorney(s)-in-Fact with power and authority hereby conferred to sign, seal and execute in its behalf all lawful bonds, undertakings and other obligatory instruments of similar nature provided that no single obligation shall exceed \$25,000,000.00 and to bind the Companies thereby as fully and to the same extent as if such instruments were signed by the duly authorized officers of the Companies and all of the acts of said Attorney, pursuant to the authority hereby given and hereby ratified and confirmed.

The Authority hereby granted shall expire the 24th day of August, 2024 unless sooner revoked by United Fire & Casualty Company, United Fire & Indemnity Company, and Financial Pacific Insurance Company.

This Power of Attorney is made and executed pursuant to and by authority of the following bylaw duly adopted by the Boards of Directors of United Fire & Casualty Company, United Fire & Indemnity Company, and Financial Pacific Insurance Company.

**“Article VI – Surety Bonds and Undertakings”**

Section 2, Appointment of Attorney-in-Fact. “The President or any Vice President, or any other officer of the Companies may, from time to time, appoint by written certificates attorneys-in-fact to act in behalf of the Companies in the execution of policies of insurance, bonds, undertakings and other obligatory instruments of like nature. The signature of any officer authorized hereby, and the Corporate seal, may be affixed by facsimile to any power of attorney or special power of attorney or certification of either authorized hereby; such signature and seal, when so used, being adopted by the Companies as the original signature of such officer and the original seal of the Companies, to be valid and binding upon the Companies with the same force and effect as though manually affixed. Such attorneys-in-fact, subject to the limitations set of forth in their respective certificates of authority shall have full power to bind the Companies by their signature and execution of any such instruments and to attach the seal the Companies thereto. The President or any Vice President, the Board of Directors or any other officer of the Companies may at any time revoke all power and authority previously given to any attorney-in-fact.

IN WITNESS WHEREOF, the COMPANIES have each caused these presents to be signed by its vice president and its corporate seal to be hereto affixed this 24th day of August, 2022



UNITED FIRE & CASUALTY COMPANY  
 UNITED FIRE & INDEMNITY COMPANY  
 FINANCIAL PACIFIC INSURANCE COMPANY

By: *Dennis J. Richmann*  
 Vice President

State of Iowa, County of Linn, ss:

On 24th day of August, 2022, before me personally came Dennis J. Richmann to me known, who being by me duly sworn, did depose and say; that he resides in Cedar Rapids, State of Iowa; that he is a Vice President of United Fire & Casualty Company, a Vice President of United Fire & Indemnity Company, and a Vice President of Financial Pacific Insurance Company the corporations described in and which executed the above instrument; that he knows the seal of said corporations; that the seal affixed to the said instrument is such corporate seal; that it was so affixed pursuant to authority given by the Board of Directors of said corporations and that he signed his name thereto pursuant to like authority, and acknowledges same to be the act and deed of said corporations.



*Judith A. Jones*  
 Notary Public  
 My commission expires: 4/23/2024

I, Mary A. Bertsch, Assistant Secretary of United Fire & Casualty Company and Assistant Secretary of United Fire & Indemnity Company, and Assistant Secretary of Financial Pacific Insurance Company, do hereby certify that I have compared the foregoing copy of the Power of Attorney and affidavit, and the copy of the Section of the bylaws and resolutions of said Corporations as set forth in said Power of Attorney, with the ORIGINALS ON FILE IN THE HOME OFFICE OF SAID CORPORATIONS, and that the same are correct transcripts thereof, and of the whole of the said originals, and that the said Power of Attorney has not been revoked and is now in full force and effect.

In testimony whereof I have hereunto subscribed my name and affixed the corporate seal of the said Corporations this 17th day of July, 2023.



By: *Mary A. Bertsch*  
 Assistant Secretary,  
 UF&C & UF&I & FPIC



United Fire & Casualty Company  
United Fire & Indemnity Company  
Financial Pacific Insurance Company

SURETY

## SURETY BOND SEAL ADDENDUM

United Fire & Casualty Company  
PO Box 73909  
Cedar Rapids, Iowa 52407

United Fire & Casualty Company has authorized its Attorneys-in-Fact to affix United Fire & Casualty Company corporate seal to any bond executed on behalf of United Fire & Casualty Company by any such Attorney-in-Fact by attaching this Addendum to said bond.

To the extent this Addendum is attached to a bond that is executed on behalf of United Fire & Casualty Company by its Attorney-in-Fact, United Fire & Casualty Company hereby agrees that the seal below shall be deemed affixed to said bond to the same extent as if its raised corporate seal was physically affixed to the face of the bond.

Dated this 17th day of July, 2023.

United Fire & Casualty Company



By: *Dennis J. Richmann*  
Dennis J. Richmann, Vice President



**Performance Bond**

**Recitals:**

1. **Onyx Paving Company, Inc.** (Contractor) has entered into a Contract with COUNTY OF RIVERSIDE (County) for construction of public work known as **Johnston Avenue Resurfacing, San Jacinto Street to 630-Foot East of Stanford Street, Community of East Hemet, Project No. B0-0612.**
2. \_\_\_\_\_, a \_\_\_\_\_ corporation (Surety), is the Surety under this Bond.

**Agreement:**

We, Contractor as Principal and Surety as Surety, jointly and severally agree, state, and are bound unto County, as obligee, as follows:

1. The amount of the obligation of this Bond is 100% of the estimated contract price for the Project of **\$2,938,000.00 (Two million, nine hundred thirty-eight thousand dollars and zero cents)** and inures to the benefit of County.
2. This Bond is exonerated by Contractor doing all things to be kept and performed by it in strict conformance with the Contract Documents for this project, otherwise it remains in full force and effect for the recovery of loss, damage and expense of County resulting from failure of Contractor to so act. All of said Contract Documents are incorporated herein.
3. This obligation is binding on our successors and assigns.
4. For value received, Surety stipulates and agrees that no change, time extension, prepayment to Contractor, alteration or addition to the terms and requirements of the Contract Documents or the work to be performed thereunder shall affect its obligations hereunder and waives notice as to such matters, except the total contract price cannot be increased by more than 10% without approval of Surety.

THIS BOND is executed as of \_\_\_\_\_.

By \_\_\_\_\_

By \_\_\_\_\_

By \_\_\_\_\_

Type Name \_\_\_\_\_

Its Attorney in Fact  
"Surety"

Title \_\_\_\_\_

"Contractor"

(Corporate Seal)

(Corporate Seal)

**NOTE: This Bond must be executed by both parties with corporate seal affixed. All signatures must be acknowledged.** (Attach acknowledgements).

**Payment Bond**

(Public Works - Civil Code §9550 et seq.)

The makers of this Bond are **Onyx Paving Company, Inc.** as Principal and Original Contractor and \_\_\_\_\_, a corporation, authorized to issue Surety Bonds in California, as Surety, and this Bond is issued in conjunction with that certain public works contract to be executed between Principal and COUNTY OF RIVERSIDE a public entity, as Owner, for **\$2,938,000.00 (Two million, nine hundred thirty-eight thousand dollars and zero cents)** the total amount payable. The amount of this bond is one hundred percent (100%) of said sum. Said contract is for public work generally consisting of **Johnston Avenue Resurfacing, San Jacinto Street to 630-Foot East of Stanford Street, Community of East Hemet, Project No. B0-0612.**

The beneficiaries of this Bond are as is stated in 9554 of the Civil Code and requirements and conditions of this Bond are as is set forth in 9554, 9558, 9560 and 9564 of said code. Without notice, Surety consents to extension of time for performance, change in requirements, amount of compensation, or prepayment under said contract.

Dated: \_\_\_\_\_

\_\_\_\_\_  
Original Contractor – Principal

\_\_\_\_\_  
Surety

By \_\_\_\_\_

By \_\_\_\_\_

Its Attorney In Fact

Title \_\_\_\_\_

(If corporation, affix seal)

(Corporate Seal)

(Corporate Seal)

STATE  
OF \_\_\_\_\_  
COUNTY  
OF \_\_\_\_\_

} ss. SURETY'S ACKNOWLEDGEMENT

On \_\_\_\_\_ before me, \_\_\_\_\_ personally appeared, \_\_\_\_\_, known to me, or proved to me on the basis of satisfactory evidence, to be the person whose name is subscribed to the within instrument and acknowledged to me that he executed the same in his authorized capacities, and that by his signature on the instrument the person, or the entity upon behalf of which the person acted, executed the instrument.

WITNESS my hand and official seal.

\_\_\_\_\_  
Signature of Notary Public

Notary Public (Seal)

**NOTE: This Bond must be executed by both parties with corporate seal affixed. All signatures must be acknowledged. (Attach acknowledgements).**



# CERTIFICATE OF LIABILITY INSURANCE

DATE (MM/DD/YYYY)

8/23/2023

THIS CERTIFICATE IS ISSUED AS A MATTER OF INFORMATION ONLY AND CONFERS NO RIGHTS UPON THE CERTIFICATE HOLDER. THIS CERTIFICATE DOES NOT AFFIRMATIVELY OR NEGATIVELY AMEND, EXTEND OR ALTER THE COVERAGE AFFORDED BY THE POLICIES BELOW. THIS CERTIFICATE OF INSURANCE DOES NOT CONSTITUTE A CONTRACT BETWEEN THE ISSUING INSURER(S), AUTHORIZED REPRESENTATIVE OR PRODUCER, AND THE CERTIFICATE HOLDER.

**IMPORTANT:** If the certificate holder is an ADDITIONAL INSURED, the policy(ies) must have ADDITIONAL INSURED provisions or be endorsed. If SUBROGATION IS WAIVED, subject to the terms and conditions of the policy, certain policies may require an endorsement. A statement on this certificate does not confer rights to the certificate holder in lieu of such endorsement(s).

<b>PRODUCER</b> Burnham WGB Insurance Solutions CA Insurance License 0F69771 15901 Red Hill Avenue Tustin CA 92780  License#: 0F69771	<b>CONTACT NAME:</b> Michael Tran <b>PHONE (A/C, No, Ext):</b> 714-824-8384 <b>FAX (A/C, No):</b> 714-573-1770 <b>E-MAIL ADDRESS:</b> michael.tran@wgbib.com	
	<b>INSURER(S) AFFORDING COVERAGE</b>	
<b>INSURED</b> Onyx Paving Company, Inc. 2890 E. La Cresta Avenue Anaheim CA 92806-1816  License#: ONYXPAV-01	<b>INSURER A :</b> Zurich American Insurance Comp <b>NAIC #</b> 16535	
	<b>INSURER B :</b> American Zurich Insurance Comp <b>NAIC #</b> 40142	
	<b>INSURER C :</b> Scottsdale Insurance Company <b>NAIC #</b> 41297	
	<b>INSURER D :</b>	
	<b>INSURER E :</b>	
	<b>INSURER F :</b>	

**COVERAGES****CERTIFICATE NUMBER:** 2084335818**REVISION NUMBER:**

THIS IS TO CERTIFY THAT THE POLICIES OF INSURANCE LISTED BELOW HAVE BEEN ISSUED TO THE INSURED NAMED ABOVE FOR THE POLICY PERIOD INDICATED. NOTWITHSTANDING ANY REQUIREMENT, TERM OR CONDITION OF ANY CONTRACT OR OTHER DOCUMENT WITH RESPECT TO WHICH THIS CERTIFICATE MAY BE ISSUED OR MAY PERTAIN, THE INSURANCE AFFORDED BY THE POLICIES DESCRIBED HEREIN IS SUBJECT TO ALL THE TERMS, EXCLUSIONS AND CONDITIONS OF SUCH POLICIES. LIMITS SHOWN MAY HAVE BEEN REDUCED BY PAID CLAIMS.

INSR LTR	TYPE OF INSURANCE	ADDL SUBR INSD WVD	POLICY NUMBER	POLICY EFF (MM/DD/YYYY)	POLICY EXP (MM/DD/YYYY)	LIMITS
C	<b>COMMERCIAL GENERAL LIABILITY</b> <input type="checkbox"/> CLAIMS-MADE <input checked="" type="checkbox"/> OCCUR  GEN'L AGGREGATE LIMIT APPLIES PER: <input type="checkbox"/> POLICY <input checked="" type="checkbox"/> PROJECT <input type="checkbox"/> LOC OTHER:		BCS2000426	3/14/2023	3/14/2024	EACH OCCURRENCE \$ 2,000,000 DAMAGE TO RENTED PREMISES (Ea occurrence) \$ 100,000 MED EXP (Any one person) \$ Excluded PERSONAL & ADV INJURY \$ 2,000,000 GENERAL AGGREGATE \$ 4,000,000 PRODUCTS - COMP/OP AGG \$ 4,000,000 \$
B	<b>AUTOMOBILE LIABILITY</b> <input checked="" type="checkbox"/> ANY AUTO <input type="checkbox"/> OWNED AUTOS ONLY <input type="checkbox"/> SCHEDULED AUTOS NON-OWNED AUTOS ONLY <input checked="" type="checkbox"/> HIRED AUTOS ONLY		BAP106300604	10/1/2022	10/1/2023	COMBINED SINGLE LIMIT (Ea accident) \$ 2,000,000 BODILY INJURY (Per person) \$ BODILY INJURY (Per accident) \$ PROPERTY DAMAGE (Per accident) \$ \$
	<b>UMBRELLA LIAB</b> <input type="checkbox"/> OCCUR <b>EXCESS LIAB</b> <input type="checkbox"/> CLAIMS-MADE DED RETENTION \$					EACH OCCURRENCE \$ AGGREGATE \$ \$
A	<b>WORKERS COMPENSATION AND EMPLOYERS' LIABILITY</b> ANY PROPRIETOR/PARTNER/EXECUTIVE OFFICER/MEMBER EXCLUDED? (Mandatory in NH) If yes, describe under DESCRIPTION OF OPERATIONS below	Y/N <input checked="" type="checkbox"/> Y <input type="checkbox"/> N/A	WC106300504	10/1/2022	10/1/2023	<input checked="" type="checkbox"/> PER STATUTE <input type="checkbox"/> OTHER E.L. EACH ACCIDENT \$ 1,000,000 E.L. DISEASE - EA EMPLOYEE \$ 1,000,000 E.L. DISEASE - POLICY LIMIT \$ 1,000,000

**DESCRIPTION OF OPERATIONS / LOCATIONS / VEHICLES (ACORD 101, Additional Remarks Schedule, may be attached if more space is required)**  
 Certificate holder(s) is/are named as additional insured per the attached endorsements as required by written contract subject to the terms & conditions of the policy:

GL Additional Insured Form #CG 20 10 12 19 and CG 20 37 12 19  
 GL Additional Insured State-Permits Form #CG 20 12 12 19  
 GL Primary and Non-Contributory Form #CG 20 01 12 19  
 GL Waiver of Subrogation Form #CG 24 04 12 19  
 GL Per Project Form #GLS-332s 01 12  
 See Attached...

**CERTIFICATE HOLDER**

County of Riverside  
 Transportation Department  
 Attn: Contracts/Bidding Unit  
 3525 14th Street  
 Riverside CA 92501

**CANCELLATION**

SHOULD ANY OF THE ABOVE DESCRIBED POLICIES BE CANCELLED BEFORE THE EXPIRATION DATE THEREOF, NOTICE WILL BE DELIVERED IN ACCORDANCE WITH THE POLICY PROVISIONS.

AUTHORIZED REPRESENTATIVE

© 1988-2015 ACORD CORPORATION. All rights reserved.



**ADDITIONAL REMARKS SCHEDULE**

AGENCY Burnham WGB Insurance Solutions		NAMED INSURED Onyx Paving Company, Inc. 2890 E. La Cresta Avenue Anaheim CA 92806-1816	
POLICY NUMBER		EFFECTIVE DATE:	
CARRIER	NAIC CODE		

**ADDITIONAL REMARKS**

**THIS ADDITIONAL REMARKS FORM IS A SCHEDULE TO ACORD FORM,**  
**FORM NUMBER:** 25 **FORM TITLE:** CERTIFICATE OF LIABILITY INSURANCE

Auto Additional Insured, Primary & Non-Contributory, and Waiver of Subrogation Form #U-CA-424-F CW 04 14  
 WC Waiver of Subrogation Form #WC 04 03 06  
 RE: Job #23-079. Johnston Avenue Resurfacing

Certificate Holder Vesting:  
 County of Riverside, its Agencies, Special Districts and Departments, their respective director, officers, Board of Supervisors, elected and appointed officials, employees, agents, and representatives; Lake Hemet Municipal Water District, their elected or appointed officials, directors, employees, and agents; Eastern Municipal Water District, their elected or appointed officials, directors, employees, and agents

**THIS ENDORSEMENT CHANGES THE POLICY. PLEASE READ IT CAREFULLY.**

**ADDITIONAL INSURED – OWNERS, LESSEES OR  
CONTRACTORS – SCHEDULED PERSON OR  
ORGANIZATION**

This endorsement modifies insurance provided under the following:

COMMERCIAL GENERAL LIABILITY COVERAGE PART

**SCHEDULE**

Name Of Additional Insured Person(s) Or Organization(s)	Location(s) Of Covered Operations
ANY PERSON OR ORGANIZATION WHEN REQUIRED BY WRITTEN CONTRACT OR AGREEMENT, EXECUTED PRIOR TO THE OCCURRENCE TO WHICH THIS INSURANCE APPLIES, THAT SUCH PERSON OR ORGANIZATION BE ADDED AS AN ADDITIONAL INSURED ON YOUR POLICY.	ALL LOCATIONS
Information required to complete this Schedule, if not shown above, will be shown in the Declarations.	

**A. Section II – Who Is An Insured** is amended to include as an additional insured the person(s) or organization(s) shown in the Schedule, but only with respect to liability for "bodily injury", "property damage" or "personal and advertising injury" caused, in whole or in part, by:

1. Your acts or omissions; or
2. The acts or omissions of those acting on your behalf;

in the performance of your ongoing operations for the additional insured(s) at the location(s) designated above.

However:

1. The insurance afforded to such additional insured only applies to the extent permitted by law; and
2. If coverage provided to the additional insured is required by a contract or agreement, the insurance afforded to such additional insured will not be broader than that which you are required by the contract or agreement to provide for such additional insured.

**B.** With respect to the insurance afforded to these additional insureds, the following additional exclusions apply:

This insurance does not apply to "bodily injury" or "property damage" occurring after:

1. All work, including materials, parts or equipment furnished in connection with such work, on the project (other than service, maintenance or repairs) to be performed by or on behalf of the additional insured(s) at the location of the covered operations has been completed; or
2. That portion of "your work" out of which the injury or damage arises has been put to its intended use by any person or organization other than another contractor or subcontractor engaged in performing operations for a principal as a part of the same project.

C. With respect to the insurance afforded to these additional insureds, the following is added to **Section III – Limits Of Insurance:**

If coverage provided to the additional insured is required by a contract or agreement, the most we will pay on behalf of the additional insured is the amount of insurance:

1. Required by the contract or agreement; or

2. Available under the applicable limits of insurance;

whichever is less.

This endorsement shall not increase the applicable limits of insurance.

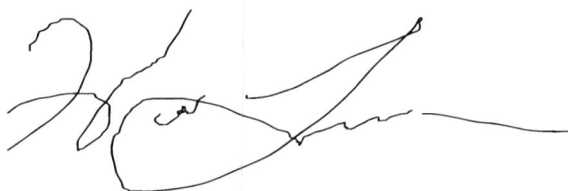

Wade Lupe  
Broker Representative

**THIS ENDORSEMENT CHANGES THE POLICY. PLEASE READ IT CAREFULLY.**

**ADDITIONAL INSURED – OWNERS, LESSEES OR CONTRACTORS – COMPLETED OPERATIONS**

This endorsement modifies insurance provided under the following:

COMMERCIAL GENERAL LIABILITY COVERAGE PART  
PRODUCTS/COMPLETED OPERATIONS LIABILITY COVERAGE PART

**SCHEDULE**

Name Of Additional Insured Person(s) Or Organization(s)	Location And Description Of Completed Operations
ANY PERSON OR ORGANIZATION WHEN REQUIRED BY WRITTEN CONTRACT OR AGREEMENT, EXECUTED PRIOR TO THE OCCURRENCE TO WHICH THIS INSURANCE	ALL LOCATIONS
APPLIES, THAT SUCH PERSON OR ORGANIZATION BE ADDED AS AN ADDITIONAL INSURED ON YOUR POLICY.	
Information required to complete this Schedule, if not shown above, will be shown in the Declarations.	

**A. Section II – Who Is An Insured** is amended to include as an additional insured the person(s) or organization(s) shown in the Schedule, but only with respect to liability for "bodily injury" or "property damage" caused, in whole or in part, by "your work" at the location designated and described in the Schedule of this endorsement performed for that additional insured and included in the "products-completed operations hazard".

However:

1. The insurance afforded to such additional insured only applies to the extent permitted by law; and
2. If coverage provided to the additional insured is required by a contract or agreement, the insurance afforded to such additional insured will not be broader than that which you are required by the contract or agreement to provide for such additional insured.

**B. With respect to the insurance afforded to these additional insureds, the following is added to Section III – Limits Of Insurance:**

If coverage provided to the additional insured is required by a contract or agreement, the most we will pay on behalf of the additional insured is the amount of insurance:

1. Required by the contract or agreement; or
2. Available under the applicable limits of insurance;

whichever is less.

This endorsement shall not increase the applicable limits of insurance.



Wade Lupe - Broker Representative

THIS ENDORSEMENT CHANGES THE POLICY. PLEASE READ IT CAREFULLY.

**ADDITIONAL INSURED – STATE OR GOVERNMENTAL  
AGENCY OR SUBDIVISION OR POLITICAL  
SUBDIVISION – PERMITS OR AUTHORIZATIONS**

This endorsement modifies insurance provided under the following:

COMMERCIAL GENERAL LIABILITY COVERAGE PART

**SCHEDULE**

**State Or Governmental Agency Or Subdivision Or Political Subdivision:**

ANY PERSON OR ORGANIZATION WHEN REQUIRED BY WRITTEN CONTRACT OR AGREEMENT, EXECUTED PRIOR TO THE OCCURRENCE TO WHICH THIS INSURANCE APPLIES, THAT SUCH PERSON OR ORGANIZATION BE ADDED AS AN ADDITIONAL INSURED ON YOUR POLICY.

Information required to complete this Schedule, if not shown above, will be shown in the Declarations.

**A. Section II – Who Is An Insured** is amended to include as an additional insured any state or governmental agency or subdivision or political subdivision shown in the Schedule, subject to the following provisions:

- 1. This insurance applies only with respect to operations performed by you or on your behalf for which the state or governmental agency or subdivision or political subdivision has issued a permit or authorization.

However:

- a. The insurance afforded to such additional insured only applies to the extent permitted by law; and
- b. If coverage provided to the additional insured is required by a contract or agreement, the insurance afforded to such additional insured will not be broader than that which you are required by the contract or agreement to provide for such additional insured.



Wade Lupe - Broker  
Representative

2. This insurance does not apply to:

- a. "Bodily injury", "property damage" or "personal and advertising injury" arising out of operations performed for the federal government, state or municipality; or
- b. "Bodily injury" or "property damage" included within the "products-completed operations hazard".

**B. With respect to the insurance afforded to these additional insureds, the following is added to Section III – Limits Of Insurance:**

If coverage provided to the additional insured is required by a contract or agreement, the most we will pay on behalf of the additional insured is the amount of insurance:

- 1. Required by the contract or agreement; or
- 2. Available under the applicable limits of insurance;

whichever is less.

This endorsement shall not increase the applicable limits of insurance.



**THIS ENDORSEMENT CHANGES THE POLICY. PLEASE READ IT CAREFULLY.**

**PRIMARY AND NONCONTRIBUTORY –  
OTHER INSURANCE CONDITION**

This endorsement modifies insurance provided under the following:

COMMERCIAL GENERAL LIABILITY COVERAGE PART  
LIQUOR LIABILITY COVERAGE PART  
PRODUCTS/COMPLETED OPERATIONS LIABILITY COVERAGE PART

The following is added to the **Other Insurance** Condition and supersedes any provision to the contrary:

**Primary And Noncontributory Insurance**

This insurance is primary to and will not seek contribution from any other insurance available to an additional insured under your policy provided that:

- (1) The additional insured is a Named Insured under such other insurance; and

- (2) You have agreed in writing in a contract or agreement that this insurance would be primary and would not seek contribution from any other insurance available to the additional insured.

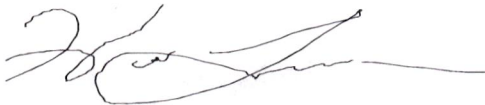

Wade Lupe - Broker  
Representative

**THIS ENDORSEMENT CHANGES THE POLICY. PLEASE READ IT CAREFULLY.**

**WAIVER OF TRANSFER OF RIGHTS OF RECOVERY  
AGAINST OTHERS TO US (WAIVER OF SUBROGATION)**

This endorsement modifies insurance provided under the following:

- COMMERCIAL GENERAL LIABILITY COVERAGE PART
- ELECTRONIC DATA LIABILITY COVERAGE PART
- LIQUOR LIABILITY COVERAGE PART
- POLLUTION LIABILITY COVERAGE PART DESIGNATED SITES
- POLLUTION LIABILITY LIMITED COVERAGE PART DESIGNATED SITES
- PRODUCTS/COMPLETED OPERATIONS LIABILITY COVERAGE PART
- RAILROAD PROTECTIVE LIABILITY COVERAGE PART
- UNDERGROUND STORAGE TANK POLICY DESIGNATED TANKS

**SCHEDULE**

<p><b>Name Of Person(s) Or Organization(s):</b></p> <p>ANY PERSON OR ORGANIZATION FOR WHOM THE INSURED HAS AGREED TO WAIVE RIGHTS OF RECOVERY, PROVIDED SUCH AGREEMENT IS MADE IN WRITING AND PRIOR TO THE LOSS.</p>
<p>Information required to complete this Schedule, if not shown above, will be shown in the Declarations.</p>

The following is added to Paragraph 8. **Transfer Of Rights Of Recovery Against Others To Us** of Section IV – Conditions:

We waive any right of recovery against the person(s) or organization(s) shown in the Schedule above because of payments we make under this Coverage Part. Such waiver by us applies only to the extent that the insured has waived its right of recovery against such person(s) or organization(s) prior to loss. This endorsement applies only to the person(s) or organization(s) shown in the Schedule above.

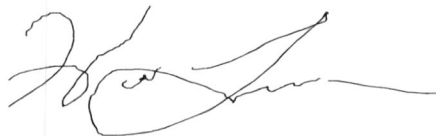

Wade Lupe - Broker  
Representative



ATTACHED TO AND FORMING A PART OF POLICY NUMBER	ENDORSEMENT EFFECTIVE DATE (12:01 A.M. STANDARD TIME)	NAMED INSURED	AGENT NO.
BCS2000426	03/14/2023	ONYX PAVING COMPANY, INC.	047BY

THIS ENDORSEMENT CHANGES THE POLICY. PLEASE READ IT CAREFULLY.

**DESIGNATED CONSTRUCTION PROJECT(S) AGGREGATE LIMIT  
SUBJECT TO AN ALL PROJECTS LIMIT**

This endorsement modifies insurance provided under the following:

**COMMERCIAL GENERAL LIABILITY COVERAGE PART**

**SCHEDULE**

**Designated Construction Project(s):** ALL PROJECTS

Information required to complete this Schedule, if not shown above, will be shown in the Declarations.

- A.** For all sums which the insured becomes legally obligated to pay as damages caused by "occurrences" under Section I—Coverage A, and for all medical expenses caused by accidents under Section I—Coverage C, which can be attributed only to ongoing operations at a single designated construction project shown in the Schedule above:
1. A separate Designated Per Project Aggregate Limit equal to the General Aggregate Limit shown in the Declarations shall apply to each Designated Construction Project.  
  
However, the most we will pay under the insurance provided by this endorsement for all Designated Construction Projects shown in the Schedule above is \$5,000,000, unless otherwise stated below:  
  
\$
  2. The separate Designated Per Project Aggregate Limit provided in A.1. above is the most we will pay for the sum of all damages under Coverage A, except damages because of "bodily injury" or "property damage" included in the "products-completed operations hazard," and for medical expenses under Coverage C regardless of the number of:
    - a. Insureds;
    - b. Claims made or "suits" brought; or
    - c. Persons or organizations making claims or bringing "suits."
  3. Any payments made under Coverage A for damages or under Coverage C for medical expenses shall reduce the separate Designated Per Project Aggregate Limit provided in A.1. for that particular Designated Construction Project. Such payments

shall not reduce the General Aggregate Limit shown in the Declarations, nor shall they reduce the insurance provided by this endorsement for any other Designated Construction Project.

4. The limits shown in the Declarations for Each Occurrence, Damage To Premises Rented To You and Medical Expense continue to apply. However, instead of being subject to the General Aggregate Limit shown in the Declarations, such limits will be subject to the applicable separate Designated Per Project Aggregate Limit provided in A.1. for each Designated Construction Project.
- B.** For all sums which the insured becomes legally obligated to pay as damages caused by "occurrence" under Section I—Coverage A, and for all medical expenses caused by accidents under Section I—Coverage C, which cannot be attributed only to ongoing operations at a single designated construction project shown in the Schedule above:
1. Any payments made under Coverage A for damages or under Coverage C for medical expenses shall reduce the amount available under the General Aggregate Limit or the Products-Completed

Operations Aggregate Limit, whichever is applicable; and

2. Such payments shall not reduce any separate Designated Per Project Aggregate Limit provided in A.1.
- C.** When coverage for liability arising out of the "products-completed operations hazard" is provided, any payments for damages because of "bodily injury" or "property damage" included in the "products-completed operations hazard" will reduce the Products-Completed Operations Aggregate Limit, and not reduce the General Aggregate Limit nor any separate Designated Per Project Aggregate Limit provided in A.1.
- D.** If the applicable designated construction project has been abandoned, delayed, or abandoned and then restarted, or if the authorized contracting parties deviate from plans, blueprints, designs, specifications or timetables, the project will still be deemed to be the same construction project.
- E.** The provisions of Section III—Limits Of Insurance not otherwise modified by this endorsement shall continue to apply as stipulated.



Wade Lupe - Broker Representative

\_\_\_\_\_  
AUTHORIZED REPRESENTATIVE

\_\_\_\_\_  
DATE

Includes copyrighted material of ISO Properties, Inc., with its permission.  
Copyright, ISO Properties, Inc., 2008



# Coverage Extension Endorsement

Policy No.	Eff. Date of Pol.	Exp. Date of Pol.	Eff. Date of End.	Producer No.	Add'l. Prem	Return Prem.
BAP 1063006-04	10/01/2022	10/01/2023		39774000	<b>INCL</b>	

**THIS ENDORSEMENT CHANGES THE POLICY. PLEASE READ IT CAREFULLY.**

This endorsement modifies insurance provided under the:

**Business Auto Coverage Form  
Motor Carrier Coverage Form**

## A. Amended Who Is An Insured

1. The following is added to the **Who Is An Insured** Provision in **Section II – Covered Autos Liability Coverage**:

The following are also "insureds":

- a. Any "employee" of yours is an "insured" while using a covered "auto" you don't own, hire or borrow for acts performed within the scope of employment by you. Any "employee" of yours is also an "insured" while operating an "auto" hired or rented under a contract or agreement in an "employee's" name, with your permission, while performing duties related to the conduct of your business.
  - b. Anyone volunteering services to you is an "insured" while using a covered "auto" you don't own, hire or borrow to transport your clients or other persons in activities necessary to your business.
  - c. Anyone else who furnishes an "auto" referenced in Paragraphs **A.1.a.** and **A.1.b.** in this endorsement.
  - d. Where and to the extent permitted by law, any person(s) or organization(s) where required by written contract or written agreement with you executed prior to any "accident", including those person(s) or organization(s) directing your work pursuant to such written contract or written agreement with you, provided the "accident" arises out of operations governed by such contract or agreement and only up to the limits required in the written contract or written agreement, or the Limits of Insurance shown in the Declarations, whichever is less.
2. The following is added to the **Other Insurance** Condition in the Business Auto Coverage Form and the **Other Insurance – Primary and Excess Insurance Provisions Condition** in the Motor Carrier Coverage Form:

Coverage for any person(s) or organization(s), where required by written contract or written agreement with you executed prior to any "accident", will apply on a primary and non-contributory basis and any insurance maintained by the additional "insured" will apply on an excess basis. However, in no event will this coverage extend beyond the terms and conditions of the Coverage Form.

## B. Amendment – Supplementary Payments

Paragraphs **a.(2)** and **a.(4)** of the **Coverage Extensions** Provision in **Section II – Covered Autos Liability Coverage** are replaced by the following:

- (2) Up to \$5,000 for the cost of bail bonds (including bonds for related traffic law violations) required because of an "accident" we cover. We do not have to furnish these bonds.
- (4) All reasonable expenses incurred by the "insured" at our request, including actual loss of earnings up to \$500 a day because of time off from work.

**C. Fellow Employee Coverage**

The **Fellow Employee** Exclusion contained in **Section II – Covered Autos Liability Coverage** does not apply.

**D. Driver Safety Program Liability and Physical Damage Coverage**

1. The following is added to the **Racing** Exclusion in **Section II – Covered Autos Liability Coverage**:

This exclusion does not apply to covered "autos" participating in a driver safety program event, such as, but not limited to, auto or truck rodeos and other auto or truck agility demonstrations.

2. The following is added to Paragraph 2. in the **Exclusions** of **Section III – Physical Damage Coverage** of the Business Auto Coverage Form and Paragraph 2.b. in the **Exclusions** of **Section IV – Physical Damage Coverage** of the Motor Carrier Coverage Form:

This exclusion does not apply to covered "autos" participating in a driver safety program event, such as, but not limited to, auto or truck rodeos and other auto or truck agility demonstrations.

**E. Lease or Loan Gap Coverage**

The following is added to the **Coverage** Provision of the **Physical Damage Coverage** Section:

**Lease Or Loan Gap Coverage**

In the event of a total "loss" to a covered "auto", we will pay any unpaid amount due on the lease or loan for a covered "auto", less:

- a. Any amount paid under the **Physical Damage Coverage** Section of the Coverage Form; and
- b. Any:
  - (1) Overdue lease or loan payments at the time of the "loss";
  - (2) Financial penalties imposed under a lease for excessive use, abnormal wear and tear or high mileage;
  - (3) Security deposits not returned by the lessor;
  - (4) Costs for extended warranties, credit life insurance, health, accident or disability insurance purchased with the loan or lease; and
  - (5) Carry-over balances from previous leases or loans.

**F. Towing and Labor**

Paragraph **A.2.** of the **Physical Damage Coverage** Section is replaced by the following:

We will pay up to \$75 for towing and labor costs incurred each time a covered "auto" of the private passenger type is disabled. However, the labor must be performed at the place of disablement.

**G. Extended Glass Coverage**

The following is added to Paragraph **A.3.a.** of the **Physical Damage Coverage** Section:

If glass must be replaced, the deductible shown in the Declarations will apply. However, if glass can be repaired and is actually repaired rather than replaced, the deductible will be waived. You have the option of having the glass repaired rather than replaced.

**H. Hired Auto Physical Damage – Increased Loss of Use Expenses**

The **Coverage Extension** for **Loss Of Use Expenses** in the **Physical Damage Coverage** Section is replaced by the following:

**Loss Of Use Expenses**

For Hired Auto Physical Damage, we will pay expenses for which an "insured" becomes legally responsible to pay for loss of use of a vehicle rented or hired without a driver under a written rental contract or written rental agreement. We will pay for loss of use expenses if caused by:

- (1) Other than collision only if the Declarations indicate that Comprehensive Coverage is provided for any covered "auto";
  - (2) Specified Causes Of Loss only if the Declarations indicate that Specified Causes Of Loss Coverage is provided for any covered "auto"; or
  - (3) Collision only if the Declarations indicate that Collision Coverage is provided for any covered "auto".
- However, the most we will pay for any expenses for loss of use is \$100 per day, to a maximum of \$3000.

**I. Personal Effects Coverage**

The following is added to the **Coverage** Provision of the **Physical Damage Coverage** Section:

**Personal Effects Coverage**

- a. We will pay up to \$750 for "loss" to personal effects which are:
  - (1) Personal property owned by an "insured"; and
  - (2) In or on a covered "auto".
- b. Subject to Paragraph a. above, the amount to be paid for "loss" to personal effects will be based on the lesser of:
  - (1) The reasonable cost to replace; or
  - (2) The actual cash value.
- c. The coverage provided in Paragraphs a. and b. above, only applies in the event of a total theft of a covered "auto". No deductible applies to this coverage. However, we will not pay for "loss" to personal effects of any of the following:
  - (1) Accounts, bills, currency, deeds, evidence of debt, money, notes, securities, or commercial paper or other documents of value.
  - (2) Bullion, gold, silver, platinum, or other precious alloys or metals; furs or fur garments; jewelry, watches, precious or semi-precious stones.
  - (3) Paintings, statuary and other works of art.
  - (4) Contraband or property in the course of illegal transportation or trade.
  - (5) Tapes, records, discs or other similar devices used with audio, visual or data electronic equipment.

Any coverage provided by this Provision is excess over any other insurance coverage available for the same "loss".

**J. Tapes, Records and Discs Coverage**

1. The Exclusion in Paragraph **B.4.a.** of **Section III – Physical Damage Coverage** in the Business Auto Coverage Form and the Exclusion in Paragraph **B.2.c.** of **Section IV – Physical Damage Coverage** in the Motor Carrier Coverage Form does not apply.
2. The following is added to Paragraph **1.a. Comprehensive Coverage** under the **Coverage** Provision of the **Physical Damage Coverage** Section:

We will pay for "loss" to tapes, records, discs or other similar devices used with audio, visual or data electronic equipment. We will pay only if the tapes, records, discs or other similar audio, visual or data electronic devices:

- (a) Are the property of an "insured"; and
- (b) Are in a covered "auto" at the time of "loss".

The most we will pay for such "loss" to tapes, records, discs or other similar devices is \$500. The **Physical Damage Coverage Deductible** Provision does not apply to such "loss".

#### **K. Airbag Coverage**

The Exclusion in Paragraph **B.3.a.** of **Section III – Physical Damage Coverage** in the Business Auto Coverage Form and the Exclusion in Paragraph **B.4.a.** of **Section IV – Physical Damage Coverage** in the Motor Carrier Coverage Form does not apply to the accidental discharge of an airbag.

#### **L. Two or More Deductibles**

The following is added to the **Deductible** Provision of the **Physical Damage Coverage** Section:

If an accident is covered both by this policy or Coverage Form and by another policy or Coverage Form issued to you by us, the following applies for each covered "auto" on a per vehicle basis:

1. If the deductible on this policy or Coverage Form is the smaller (or smallest) deductible, it will be waived; or
2. If the deductible on this policy or Coverage Form is not the smaller (or smallest) deductible, it will be reduced by the amount of the smaller (or smallest) deductible.

#### **M. Physical Damage – Comprehensive Coverage – Deductible**

The following is added to the **Deductible** Provision of the **Physical Damage Coverage** Section:

Regardless of the number of covered "autos" damaged or stolen, the maximum deductible that will be applied to Comprehensive Coverage for all "loss" from any one cause is \$5,000 or the deductible shown in the Declarations, whichever is greater.

#### **N. Temporary Substitute Autos – Physical Damage**

1. The following is added to **Section I – Covered Autos**:

##### **Temporary Substitute Autos – Physical Damage**

If Physical Damage Coverage is provided by this Coverage Form on your owned covered "autos", the following types of vehicles are also covered "autos" for Physical Damage Coverage:

Any "auto" you do not own when used with the permission of its owner as a temporary substitute for a covered "auto" you do own but is out of service because of its:

1. Breakdown;
  2. Repair;
  3. Servicing;
  4. "Loss"; or
  5. Destruction.
2. The following is added to the Paragraph **A. Coverage** Provision of the **Physical Damage Coverage** Section:

##### **Temporary Substitute Autos – Physical Damage**

We will pay the owner for "loss" to the temporary substitute "auto" unless the "loss" results from fraudulent acts or omissions on your part. If we make any payment to the owner, we will obtain the owner's rights against any other party.

The deductible for the temporary substitute "auto" will be the same as the deductible for the covered "auto" it replaces.

#### **O. Amended Duties In The Event Of Accident, Claim, Suit Or Loss**

Paragraph **a.** of the **Duties In The Event Of Accident, Claim, Suit Or Loss** Condition is replaced by the following:

- a. In the event of "accident", claim, "suit" or "loss", you must give us or our authorized representative prompt notice of the "accident", claim, "suit" or "loss". However, these duties only apply when the "accident", claim, "suit" or "loss" is known to you (if you are an individual), a partner (if you are a partnership), a member (if you are a limited liability company) or an executive officer or insurance manager (if you are a corporation). The failure of any



agent, servant or employee of the "insured" to notify us of any "accident", claim, "suit" or "loss" shall not invalidate the insurance afforded by this policy.

Include, as soon as practicable:

- (1) How, when and where the "accident" or "loss" occurred and if a claim is made or "suit" is brought, written notice of the claim or "suit" including, but not limited to, the date and details of such claim or "suit";
- (2) The "insured's" name and address; and
- (3) To the extent possible, the names and addresses of any injured persons and witnesses.

If you report an "accident", claim, "suit" or "loss" to another insurer when you should have reported to us, your failure to report to us will not be seen as a violation of these amended duties provided you give us notice as soon as practicable after the fact of the delay becomes known to you.

**P. Waiver of Transfer Of Rights Of Recovery Against Others To Us**

The following is added to the **Transfer Of Rights Of Recovery Against Others To Us** Condition:

This Condition does not apply to the extent required of you by a written contract, executed prior to any "accident" or "loss", provided that the "accident" or "loss" arises out of operations contemplated by such contract. This waiver only applies to the person or organization designated in the contract.

**Q. Employee Hired Autos – Physical Damage**

Paragraph **b.** of the **Other Insurance** Condition in the Business Auto Coverage Form and Paragraph **f.** of the **Other Insurance – Primary and Excess Insurance Provisions** Condition in the Motor Carrier Coverage Form are replaced by the following:

For Hired Auto Physical Damage Coverage, the following are deemed to be covered "autos" you own:

- (1) Any covered "auto" you lease, hire, rent or borrow; and
- (2) Any covered "auto" hired or rented under a written contract or written agreement entered into by an "employee" or elected or appointed official with your permission while being operated within the course and scope of that "employee's" employment by you or that elected or appointed official's duties as respect their obligations to you.

However, any "auto" that is leased, hired, rented or borrowed with a driver is not a covered "auto".

**R. Unintentional Failure to Disclose Hazards**

The following is added to the **Concealment, Misrepresentation Or Fraud** Condition:

However, we will not deny coverage under this Coverage Form if you unintentionally:

- (1) Fail to disclose any hazards existing at the inception date of this Coverage Form; or
- (2) Make an error, omission, improper description of "autos" or other misstatement of information.

You must notify us as soon as possible after the discovery of any hazards or any other information that was not provided to us prior to the acceptance of this policy.

**S. Hired Auto – World Wide Coverage**

Paragraph **7a.(5)** of the **Policy Period, Coverage Territory** Condition is replaced by the following:

- (5) Anywhere in the world if a covered "auto" is leased, hired, rented or borrowed for a period of 60 days or less,

**T. Bodily Injury Redefined**

The definition of "bodily injury" in the **Definitions** Section is replaced by the following:

"Bodily injury" means bodily injury, sickness or disease, sustained by a person including death or mental anguish, resulting from any of these at any time. Mental anguish means any type of mental or emotional illness or disease.

**U. Expected Or Intended Injury**

The **Expected Or Intended Injury** Exclusion in Paragraph **B. Exclusions** under **Section II – Covered Auto Liability Coverage** is replaced by the following:

**Expected Or Intended Injury**

"Bodily injury" or "property damage" expected or intended from the standpoint of the "insured". This exclusion does not apply to "bodily injury" or "property damage" resulting from the use of reasonable force to protect persons or property.

**V. Physical Damage – Additional Temporary Transportation Expense Coverage**

Paragraph **A.4.a.** of **Section III – Physical Damage Coverage** is replaced by the following:

**4. Coverage Extensions**

**a. Transportation Expenses**

We will pay up to \$50 per day to a maximum of \$1,000 for temporary transportation expense incurred by you because of the total theft of a covered "auto" of the private passenger type. We will pay only for those covered "autos" for which you carry either Comprehensive or Specified Causes of Loss Coverage. We will pay for temporary transportation expenses incurred during the period beginning 48 hours after the theft and ending, regardless of the policy's expiration, when the covered "auto" is returned to use or we pay for its "loss".

**W. Replacement of a Private Passenger Auto with a Hybrid or Alternative Fuel Source Auto**

The following is added to Paragraph **A. Coverage** of the **Physical Damage Coverage** Section:

In the event of a total "loss" to a covered "auto" of the private passenger type that is replaced with a hybrid "auto" or "auto" powered by an alternative fuel source of the private passenger type, we will pay an additional 10% of the cost of the replacement "auto", excluding tax, title, license, other fees and any aftermarket vehicle upgrades, up to a maximum of \$2500. The covered "auto" must be replaced by a hybrid "auto" or an "auto" powered by an alternative fuel source within 60 calendar days of the payment of the "loss" and evidenced by a bill of sale or new vehicle lease agreement.

To qualify as a hybrid "auto", the "auto" must be powered by a conventional gasoline engine and another source of propulsion power. The other source of propulsion power must be electric, hydrogen, propane, solar or natural gas, either compressed or liquefied. To qualify as an "auto" powered by an alternative fuel source, the "auto" must be powered by a source of propulsion power other than a conventional gasoline engine. An "auto" solely propelled by biofuel, gasoline or diesel fuel or any blend thereof is not an "auto" powered by an alternative fuel source.

**X. Return of Stolen Automobile**

The following is added to the **Coverage Extension** Provision of the **Physical Damage Coverage** Section:

If a covered "auto" is stolen and recovered, we will pay the cost of transport to return the "auto" to you. We will pay only for those covered "autos" for which you carry either Comprehensive or Specified Causes of Loss Coverage.

All other terms, conditions, provisions and exclusions of this policy remain the same.



Authorized Broker

## WAIVER OF OUR RIGHT TO RECOVER FROM OTHERS ENDORSEMENT— CALIFORNIA

We have the right to recover our payments from anyone liable for an injury covered by this policy. We will not enforce our right against the person or organization named in the Schedule. (This agreement applies only to the extent that you perform work under a written contract that requires you to obtain this agreement from us.)

You must maintain payroll records accurately segregating the remuneration of your employees while engaged in the work described in the Schedule.

The additional premium for this endorsement shall be 0 % of the California workers' compensation premium otherwise due on such remuneration.

### Schedule

#### Person or Organization

#### Job Description

ALL PERSONS AND/OR ORGANIZATIONS THAT ARE REQUIRED BY WRITTEN CONTRACT OR AGREEMENT WITH THE INSURED, EXECUTED PRIOR TO THE ACCIDENT OR LOSS, THAT WAIVER OF SUBROGATION BE PROVIDED UNDER THIS POLICY FOR WORK PERFORMED BY YOU FOR THAT PERSON AND/OR ORGANIZATION.



Authorized Broker

- Company Profile
- Company Search
- Company Search Results
- Company Information
- Old Company Names
- Agent for Service
- Reference Information
- NAIC Group List
- Lines of Business
- Workers' Compensation Complaint and Request for Action/Appeals Contact Information
- Financial Statements PDF's
  - Annual Statements
  - Quarterly Statements
- Company Complaint
- Company Performance & Comparison Data
- Company Enforcement Action
- Composite Complaints Studies
- Additional Info
  - Find A Company Representative In Your Area
  - View Financial Disclaimer

**COMPANY PROFILE**

**Company Information**

**AMERICAN ZURICH INSURANCE COMPANY**

**1299 ZURICH WAY  
SCHAUMBURG, IL 60196  
800-987-3373**

**Old Company Names**

**Effective Date**

**Agent For Service**

Melissa DeKoven  
2710 Gateway Oaks Drive, Suite 150N  
Sacramento CA 95833-3505

**Reference Information**

NAIC #:	40142
California Company ID #:	2931-4
Date Authorized in California:	11/16/1983
License Status:	UNLIMITED-NORMAL
Company Type:	Property & Casualty
State of Domicile:	ILLINOIS

[back to top](#)

**NAIC Group List**

NAIC Group #: **0212** ZURICH INS GRP

**Lines Of Business**

The company is authorized to transact business within these lines of insurance. For an explanation of any of these terms, please refer to the [glossary](#).

- AUTOMOBILE
- BOILER AND MACHINERY
- BURGLARY
- COMMON CARRIER LIABILITY
- DISABILITY
- FIRE
- LIABILITY
- MARINE
- MISCELLANEOUS
- PLATE GLASS
- SPRINKLER
- TEAM AND VEHICLE
- WORKERS' COMPENSATION

[back to top](#)



- Company Profile
- Company Search
- Company Search Results
- Company Information
- Old Company Names
- Agent for Service Reference Information
- NAIC Group List
- Lines of Business
- Workers' Compensation Complaint and Request for Action/Appeals Contact Information
- Financial Statements PDF's
  - Annual Statements
  - Quarterly Statements
- Company Complaint
  - Company Performance & Comparison Data
  - Company Enforcement Action
  - Composite Complaints Studies
- Additional Info
  - Find A Company Representative In Your Area
  - View Financial Disclaimer

**COMPANY PROFILE**

**Company Information**

**ZURICH AMERICAN INSURANCE COMPANY**  
**1299 ZURICH WAY**  
**SCHAUMBURG, IL 60196**  
**800-936-5873**

**Old Company Names**

**Effective Date**

**Agent For Service**

Melissa DeKoven  
 2710 Gateway Oaks Drive, Suite 150N  
 Sacramento CA 95833-3505

**Reference Information**

NAIC #:	16535
California Company ID #:	4581-5
Date Authorized in California:	01/01/1999
License Status:	UNLIMITED-NORMAL
Company Type:	Property & Casualty
State of Domicile:	NEW YORK

[back to top](#)

**NAIC Group List**

NAIC Group #: **0212** ZURICH INS GRP

**Lines Of Business**

The company is authorized to transact business within these lines of insurance. For an explanation of any of these terms, please refer to the [glossary](#).

- AIRCRAFT
- AUTOMOBILE
- BOILER AND MACHINERY
- BURGLARY
- COMMON CARRIER LIABILITY
- CREDIT
- DISABILITY
- FIRE
- LIABILITY
- MARINE
- MISCELLANEOUS
- PLATE GLASS
- SPRINKLER
- SURETY
- TEAM AND VEHICLE
- WORKERS' COMPENSATION

[back to top](#)

ProAssurance Specialty Insurance Company (Vermont) 09/01/1995 (Name changed from Noetic Specialty Insurance Company (Vermont) effective 12/31/2021) (Domicile changed from Illinois to Vermont effective 01/18/2011) (Name changed from Coregis Indemnity Company effective 11/07/2001)	09/01/1995
Professional Security Insurance Company (Arizona)	06/03/2022
Protective Specialty Insurance Company (Indiana)	06/01/2010

[Back to Top](#)

## Q - Z

<b>Insurer</b>	<b>Date Approved</b>
QBE Specialty Insurance Company (North Dakota)	08/01/2003
QBE Europe SA/NV (Belgium)	06/03/2022
QBE UK Limited (U.K.) (Name changed from QBE Insurance (Europe) Limited effective 12/31/2018) (Name changed from QBE International Insurance Limited effective 09/30/2005)	01/06/1999
Republic-Vanguard Insurance Company (Arizona)	03/18/2022
Rockingham Insurance Company (Virginia)	2/27/2017
Scottsdale Insurance Company (Ohio)	06/30/1995
Seneca Specialty Insurance Company (Delaware) (Domicile changed from Arizona to Delaware, effective 11/25/2014)	02/02/2004
Shelter Reinsurance Company (Missouri)	10/18/2007
SiriusPoint International Insurance Corporation (Sweden) (Name changed from Sirius International Insurance Corporation effective 06/07/2021)	02/08/1999
Spinnaker Specialty Insurance Company (Texas)	06/14/2023
St. Paul Surplus Lines Insurance Company (Delaware)	07/06/1995
Starr Surplus Lines Insurance Company (Texas) (Domicile changed from Illinois to Texas effective 01/01/2018)	11/16/2010
StarStone Specialty Insurance Company (Delaware)(Name changed from Torus Specialty Insurance Company effective 09/21/2015. Name changed from Praetorian Specialty Insurance Company effective 03/02/2009. Name changed from Alea North America Specialty Insurance Company effective 10/02/2006.)	12/22/2004
Steadfast Insurance Company (Illinois) (Domicile changed from Delaware to Illinois effective 12/31/2018)	07/18/1995
Superior Specialty Insurance Company (Delaware) (Domicile changed from Missouri to Delaware and name changed from Savers Property and Casualty Insurance Company effective 1/31/2019)	6/30/1995
Swiss RE Corporate Solutions Capacity (Missouri) 02/01/1995 (Name changed from First Specialty Insurance Corporation (Missouri) effective 08/01/2022)	02/01/1995

## Bid

Date: 06/30/2023

To: County of Riverside, hereafter called "County";

Bidder: ONYX PAVING COMPANY, INC.  
(hereafter called "Contractor")

The undersigned, Contractor, having carefully examined the site and the Contract Documents for the construction of **Johnston Avenue Resurfacing, San Jacinto Street to 630-Foot East of Stanford Street, Community of East Hemet, Project No. B0-0612** hereby proposes to construct the work in accordance with the Contract Documents, including **Addenda Number(s)** 1 (Fill in addenda numbers if addenda have been issued.) for the amount stated in this Bid.

By submitting this Bid, Contractor agrees with County:

1. That unless withdrawn in person by Contractor or some person authorized in writing by Contractor (not by telephone or facsimile) before the time specified in the Notice Inviting Bids for the public opening of bids, this Bid constitutes an irrevocable offer for 90 calendar days after that date.
2. County has the right to reject any or all Bids and to waive any irregularities or informalities contained in a Bid.
3. To execute the Contract and deliver the Performance Bond, Payment Bond and Insurance Certificate with endorsements, that comply with the requirements set forth in the Instruction to Bidders and General Conditions, within ten (10) business days of the date of the Notice of Acceptance of Bid and Intent to Award as issued by the County.
4. That the contract shall be awarded upon a resolution or minute order to that effect duly adopted by the governing body of County; and that execution of the Contract shall constitute a written memorial thereof.
5. To submit to the County such information as County may require determining whether a particular Bid is the lowest responsible bid submitted.
6. That the accompanying Bid Bond, certified check or cashier's check is in an amount not less than 10% of the total bid submitted and constitutes a guarantee that if awarded the contract, Contractor will execute the Contract and deliver the required bonds within ten (10) business days after notice of award. If Contractor fails to execute and deliver said documents, the bond or check is to be charged with the costs of the resultant damages to the County, including but not limited to: publication costs, the difference in money between the amount bid and the amount in excess of the bid which it costs County to do or cause to be done for the work involved, lease and rental costs, additional salaries and overhead, increased interest and costs of funding the project, attorney expense, additional engineering and architectural expense and cost of maintaining or constructing alternate facilities occasioned by the failure to execute and deliver said documents.
7. By signing this Bid the Contractor certifies that the representations made therein are made under penalty of perjury.

**Johnston Avenue Resurfacing  
San Jacinto Street to 630-Foot East of Stanford Street  
Community of East Hemet  
Project No. B0-0612**

**REVISED PROPOSAL**

ITEM No.	ITEM CODE	ITEM	UNIT	ESTIMATED QUANTITY	ITEM PRICE (IN FIGURES)	TOTAL (IN FIGURES)
<b>BASE BID SCHEDULE - Johnston Avenue Resurfacing</b>						
1	100100	DEVELOP WATER SUPPLY	LS	1	\$11,602	\$11,602
2	120100	TRAFFIC CONTROL SYSTEM	LS	1	\$222,000	\$222,000
3	130200	PREPARE WATER POLLUTION CONTROL PROGRAM	LS	1	\$11,000	\$11,000
4	170103	CLEARING AND GRUBBING	LS	1	\$333,000	\$333,000
5	066100	DUST ABATEMENT	LS	1	\$11,000	\$11,000
6	190101(F)	ROADWAY EXCAVATION	CY	5,300	\$55	\$291,500
7	013903	PLACE ASPHALT CONCRETE DIKE (CRS 212) (6")	LF	95	\$11	\$1,045
8	013904	PLACE ASPHALT CONCRETE DIKE (CRS 212) (8")	LF	95	\$11	\$1,045
9	394075	PLACE HOT MIX ASPHALT DIKE (TYPE D) [PER CALTRANS STD A87B]	LF	1,900	\$11	\$20,900
10	394075	PLACE HOT MIX ASPHALT DIKE (TYPE D) [PER CALTRANS STD A87B, MODIFIED TO 8" HEIGHT]	LF	550	\$11	\$6,050
11	394076	PLACE HOT MIX ASPHALT DIKE (TYPE E) (PER CALTRANS STD. A87B)	LF	30	\$11	\$330
12	390132	HOT MIX ASPHALT (TYPE A)	TON	11,500	\$111	\$1,276,500
13	013905	ASPHALT CONCRETE (DRIVEWAY APPROACH WITH ASPHALT CONCRETE DIKE) (CRS 206)	SQFT	180	\$10	\$1,800
14	013905	ASPHALT CONCRETE (DRIVEWAY APPROACH WITH ASPHALT CONCRETE DIKE) (CRS 206) [MODIFIED FOR MOUNTABLE DIKE]	SQFT	6,600	\$6	\$39,600
15	013908	ASPHALT CONCRETE DRIVEWAY [3.5-INCH ON NATIVE]	SQFT	18,000	\$5	\$90,000
16	710220	ADJUST UTILITY COVER TO GRADE [WATER METER, LHMWD]	EA	15	\$2,000	\$30,000
17	710200	ADJUST MANHOLE [LHMWD]	EA	24	\$1,500	\$36,000
18	710192	ADJUST SEWER CLEANOUT TO GRADE [LHMWD]	EA	2	\$1,500	\$3,000
19	731516	MINOR CONCRETE (DRIVEWAY) [CRS 213]	SQFT	160	\$20	\$3,200



**REVISED PROPOSAL**

ITEM No.	ITEM CODE	ITEM	UNIT	ESTIMATED QUANTITY	ITEM PRICE (IN FIGURES)	TOTAL (IN FIGURES)
<b>BASE BID SCHEDULE - Johnston Avenue Resurfacing (Continued)</b>						
20	731516	MINOR CONCRETE (DRIVEWAY) [MODIFIED FOR MOUNTABLE DIKE]	SQFT	1,400	\$20	\$28,000
21	731516	MINOR CONCRETE (DRIVEWAY) [6-INCH ON NATIVE]	SQFT	950	\$20	\$19,000
22	017301	MINOR CONCRETE (DRIVEWAY APPROACH WITH ASPHALT CONCRETE DIKE) (CRS 206) [MODIFIED FOR CURB AND GUTTER]	SQFT	550	\$20	\$11,000
23	017304	MINOR CONCRETE (CURB AND GUTTER) (CRS 200)	LF	420	\$69	\$28,980
24	017315	MINOR CONCRETE (CURB RAMP) (CRS 403 - CASE A)	EA	4	\$8,400	\$33,600
25	017316	MINOR CONCRETE (CURB RAMP) (CRS 403 - CASE B) [MODIFIED PER PLAN]	EA	2	\$8,400	\$16,800
26	017317	MINOR CONCRETE (CROSS-GUTTER AND SPANDREL) (CRS 209)	SQFT	4,100	\$27	\$110,700
27	510502	MINOR CONCRETE (MINOR STRUCTURE) [CRS 308, MODIFIED FOR REVERSE FLOW INLET, WIDTH = 4']	EA	1	\$27,000	\$27,000
28	011503	UNDER SIDEWALK DRAIN CAST IN PLACE (CRS 309)	EA	1	\$16,880	\$16,880
29	731507	MINOR CONCRETE (GUTTER DEPRESSION)	EA	1	\$9,000	\$9,000
30	731521	MINOR CONCRETE (SIDEWALK) [AND 4' WALKWAYS]	SQFT	670	\$13	\$8,710
31	782110	RESET MAILBOX [OR RELOCATE MAILBOX]	EA	15	\$400	\$6,000
32	810230(F)	PAVEMENT MARKER (RETROREFLECTIVE)	EA	310	\$11	\$3,410
33	820250	REMOVE ROADSIDE SIGN [AND SALVAGE]	EA	22	\$111	\$2,442
34	820840	ROADSIDE SIGN - ONE POST	EA	22	\$373	\$8,206
35	840656(F)	PAINT TRAFFIC STRIPE (2-COAT)	LF	14,500	\$0.55	\$7,975
36	840519	THERMOPLASTIC CROSSWALK AND PAVEMENT MARKING	SQFT	675	\$7	\$4,725
37	010602	MISCELLANEOUS WORK (AS DIRECTED)	FA	1	200,000.00	200,000.00

BASE BID SCH.

TOTAL: Two million nine hundred and thirty two thousand dollars even

ITEMS 1-37

"WORDS"

\$ ~~2,821,000.00~~ (CK)  
\$2,932,000.00

**REVISED PROPOSAL**

ITEM No.	ITEM CODE	ITEM	UNIT	ESTIMATED QUANTITY	ITEM PRICE (IN FIGURES)	TOTAL (IN FIGURES)
----------	-----------	------	------	--------------------	-------------------------	--------------------

**ALTERNATIVE BID SCHEDULE 1 - EMWD Manhole Adjustments**

38	710200	ADJUST MANHOLE [EMWD]	EA	5	\$1,200	\$6,000
----	--------	-----------------------	----	---	---------	---------

ALT. BID SCH. 1

TOTAL: Six thousand dollars even \$ 6,000

ITEM 38 "WORDS"

**BASE BID SCH. + ALT. BID SCH. 1**

PROJECT

TOTAL: Two million nine hundred and thirty eight thousand dollars even \$ 2,938,000.00

ITEMS 1 - 38 "WORDS"

## Bidder Data and Signature

Name of Bidder: ONYX PAVING COMPANY, INC.

Type of organization: CORPORATION

Person(s) authorized to sign for Bidder: \_\_\_\_\_

COREY R. KIRSCHNER - CEO, PRES, VP, SEC, TREA.

Note:

If Bidder is a **Corporation**, state legal name of Corporation and also names of the president, vice-president, secretary, treasurer and manager thereof.

If Bidder is a **Co-Partnership**, state true name of firm and also names of all individual co-partners composing firm.

If Bidder is a sole proprietorship or an **Individual**, state first and last name(s) in full.

If Bid is signed by an agent other than an owner, partner or corporate officer, Bid shall be accompanied by a power-of-attorney.

Business Street Address: 2890 E. LA CRESTA AVE.  
(Please include business address even if P.O. Box is used.)

Business City, State, Zip Code: ANAHEIM, CA 92806

P.O. Box- Number: N/A

P.O. Box- City, State, Zip Code: N/A

Phone: ( ) 714-632-6699

Facsimile: ( ) 714-632-1883

E-mail: BIDS@ONYXPAVING.NET

Contractor's license number: 630360

License Classification(s): A, C12

Expiration date: 10/31/2023

Department of Industrial Relations Registration Number: 1000004798

**Bidder Data and Signature (continued)**

Accompanying this Bid is a certified check, cashier check or bid bond in an amount equal to at least ten (10) percent of the total bid for:

**Johnston Avenue Resurfacing  
San Jacinto Street to 630-Foot East of Stanford Street  
Community of East Hemet  
Project No. B0-0612**

By my signature on this Bid, I certify, under penalty of perjury under the laws of the State of California, that all the information on this form is true and correct.

IN WITNESS WHERE OF Bidder/Contractor executed this Bid as of the date set forth on page **B1** of this Bid.



**Signature:**

---

Name (printed):

**COREY R. KIRSCHNER -  
CEO, PRES, VP, SEC, TREA.**

---

Title:

**ONYX PAVING COMPANY, INC.**

---

“Contractor”



## Subcontractor List

Bidder/Contractor submits the following complete list of each Subcontractor who will perform work, labor or render service in or about the construction in an amount in excess of 1/2 of 1% of the total bid or \$10,000 whichever is greater.

Check box on right side of row if any construction item, for the listed Subcontractor, is partial work. If partial work is to be performed within a certain construction item or trade, the Bidder/Contractor shall specify the portion(s) of the work to be performed by the different subcontractors or Bidder/Contractor will be subject to provisions of Public Contract Code Section 4106.

Name of Bidder (Prime/General Contractor): ONYX PAVING COMPANY, INC.

	Subcontractor Name	License Number	DIR Registration Number	Business Address (City, State)	Construction Item(s) [Item Number and Description]	Check if Partial Work
1.	Cat Tracking Inc.	991122	1000011780	Riverside, CA	Items 32-36 Striping	<input checked="" type="checkbox"/>
2.	A.C. Dike Co.	407417	1000005929	Lincoln, CA	Items 7-11 Dike	<input checked="" type="checkbox"/>
3.	O'Duffy Construction	647025	1000006692	Romoland, CA	Items 27-29 Underground Work	<input checked="" type="checkbox"/>
4.	EB5 Utilities Adjusting Inc.	932798	1000004286	Corona, CA	Items 17-19 Utilities Adjusting	<input checked="" type="checkbox"/>
5.						<input type="checkbox"/>
6.						<input type="checkbox"/>

Additional Subcontractor List(s) may be attached to the Bid.  
(A copy of this form may be attached with additional Subcontractor information.)

Percent of work to be performed by Subcontractors: \_\_\_\_\_ %

Note: A minimum of 50% of the work is required to be performed by the prime/general Contractor.

## Subcontractor List

Bidder/Contractor submits the following complete list of each Subcontractor who will perform work, labor or render service in or about the construction in an amount in excess of 1/2 of 1% of the total bid or \$10,000 whichever is greater.

Check box on right side of row if any construction item, for the listed Subcontractor, is partial work. If partial work is to be performed within a certain construction item or trade, the Bidder/Contractor shall specify the portion(s) of the work to be performed by the different subcontractors or Bidder/Contractor will be subject to provisions of Public Contract Code Section 4106.

Name of Bidder (Prime/General Contractor): ONYX PAVING COMPANY, INC.

	Subcontractor Name	License Number	DIR Registration Number	Business Address (City, State)	Construction Item(s) [Item Number and Description]	Check if Partial Work
1.						<input type="checkbox"/>
2.						<input type="checkbox"/>
3.						<input type="checkbox"/>
4.						<input type="checkbox"/>
5.						<input type="checkbox"/>
6.						<input type="checkbox"/>

Additional Subcontractor List(s) may be attached to the Bid.  
(A copy of this form may be attached with additional Subcontractor information.)

**Percent of work to be performed by Subcontractors:** \_\_\_\_\_ %

Note: A minimum of 50% of the work is required to be performed by the prime/general Contractor.

## Non-Collusion Declaration

To be executed by bidder and submitted with bid.  
(Title 23 United States Code Section 112 and Public Contract Code Section 7106)

The undersigned declares:

I am the CEO, PRES, VP, SEC, TREA. (Title) of ONYX PAVING COMPANY, INC. (Company),  
the party making the foregoing bid.

The bid is not made in the interest of, or on behalf of, any undisclosed person, partnership, company, association, organization, or corporation. The bid is genuine and not collusive or sham. The bidder has not directly or indirectly induced or solicited any other bidder to put in a false or sham bid. The bidder has not directly or indirectly colluded, conspired, connived, or agreed with any bidder or anyone else to put in a sham bid, or that anyone shall refrain from bidding. The bidder has not in any manner, directly or indirectly, sought by agreement, communication, or conference with anyone to fix the bid price of the bidder or any other bidder, or to fix any overhead, profit, or cost element of the bid price, or of that of any other bidder.

All statements contained in the bid are true. The bidder has not, directly or indirectly, submitted his or her bid price of any breakdown thereof, or the contents thereof, or divulged information or data relative thereto, to any corporation, partnership, company, association, organization, bid depository, or to any member or agent thereof to effectuate a collusive or sham bid, and has not paid, and will not pay, any person or entity for such purpose.

Any person executing this declaration on behalf of a bidder that is a corporation, partnership, joint venture, limited liability company, limited liability partnership, or any other entity, hereby represents that he or she has full power to execute, and does execute, this declaration on behalf of the bidder.

I declare under penalty of perjury under the applicable laws that the foregoing is true and correct and that this declaration is executed on

JUNE (Month) 30th (Day) of 2023 (Year),

at ANAHEIM (City), CALIFORNIA (State).

Signature of Declarant: \_\_\_\_\_

Printed name of Declarant: COREY R. KIRSCHNER

Name of Bidder (Company): ONYX PAVING COMPANY, INC.

Title or Office: CEO, PRES, VP, SEC, TREA.

Note: Notarization of signature required.  
 Check box if attachment is included.



**CALIFORNIA ALL-PURPOSE ACKNOWLEDGMENT**

**CIVIL CODE § 1189**

A notary public or other officer completing this certificate verifies only the identity of the individual who signed the document to which this certificate is attached, and not the truthfulness, accuracy, or validity of that document.

State of California )  
County of Orange )

On June 30, 2023 before me, Carly Bredal, Notary Public,  
*Date Here Insert Name and Title of the Officer*

personally appeared Corey R. Kirschner  
*Name(s) of Signer(s)*

who proved to me on the basis of satisfactory evidence to be the person(s) whose name(s) is/are subscribed to the within instrument and acknowledged to me that he/she/they executed the same in his/her/their authorized capacity(ies), and that by his/her/their signature(s) on the instrument the person(s), or the entity upon behalf of which the person(s) acted, executed the instrument.

I certify under PENALTY OF PERJURY under the laws of the State of California that the foregoing paragraph is true and correct.

WITNESS my hand and official seal.



Signature Carly Bredal  
*Signature of Notary Public*

*Place Notary Seal Above*

**OPTIONAL**

*Though this section is optional, completing this information can deter alteration of the document or fraudulent reattachment of this form to an unintended document.*

**Description of Attached Document**

Title or Type of Document: \_\_\_\_\_ Document Date: \_\_\_\_\_  
Number of Pages: \_\_\_\_\_ Signer(s) Other Than Named Above: \_\_\_\_\_

**Capacity(ies) Claimed by Signer(s)**

Signer's Name: \_\_\_\_\_  
 Corporate Officer — Title(s): \_\_\_\_\_  
 Partner —  Limited  General  
 Individual  Attorney in Fact  
 Trustee  Guardian or Conservator  
 Other: \_\_\_\_\_  
Signer Is Representing: \_\_\_\_\_

Signer's Name: \_\_\_\_\_  
 Corporate Officer — Title(s): \_\_\_\_\_  
 Partner —  Limited  General  
 Individual  Attorney in Fact  
 Trustee  Guardian or Conservator  
 Other: \_\_\_\_\_  
Signer Is Representing: \_\_\_\_\_



## Iran Contracting Act

(Public Contract Code sections 2200-2208)

Prior to bidding on, submitting a proposal or executing a contract or renewal for a County of Riverside contract for goods or services of **\$1,000,000 or more**, a Contractor must either:

- a) Certify it is not on the current list of persons engaged in investment activities in Iran created by the California Department of General Services (“DGS”) pursuant to Public Contract Code section 2203(b) and is not a financial institution extending twenty million dollars (\$20,000,000) or more in credit to another person, for 45 days or more, if that other person will use the credit to provide goods or services in the energy sector in Iran and is identified on the current list of persons engaged in investment activities in Iran created by DGS; or
- b) Demonstrate it has been exempted from the certification requirement for that solicitation or contract pursuant to Public Contract Code section 2203(c) or (d).

To comply with this requirement, please insert your Contractor or financial institution name and Federal ID Number (if available) and complete one of the options below. Please note: California law establishes penalties for providing false certifications, including civil penalties equal to the greater of \$250,000 or twice the amount of the contract for which the false certification was made; contract termination; and three-year ineligibility to bid on contracts. (Public Contract Code section 2205.)

### **Option #1 – Certification**

I, the official named below, certify I am duly authorized to execute this certification on behalf of the vendor/financial institution identified below, and the vendor/financial institution identified below is **not** on the current list of persons engaged in investment activities in Iran created by DGS and is not a financial institution extending twenty million dollars (\$20,000,000) or more in credit to another person/vendor, for 45 days or more, if that other person/vendor will use the credit to provide goods or services in the energy sector in Iran and is identified on the current list of persons engaged in investment activities in Iran created by DGS.

<i>Contractor Name/Financial Institution (Printed)</i> <b>ONYX PAVING COMPANY, INC.</b>		<i>Federal ID Number (or n/a)</i> <b>33-0394344</b>
<i>By (Authorized Signature)</i>		
<i>Printed Name and Title of Person Signing</i> <b>COREY R. KIRSCHNER - CEO, PRES, VP, SEC, TREA.</b>		
<i>Date Executed</i> <b>06/30/2023</b>	<i>Executed in</i> <b>ANAHEIM, CA</b>	

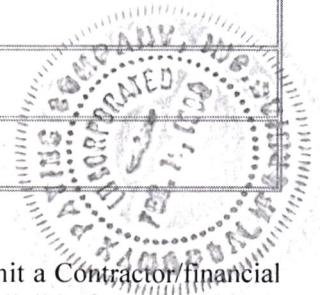

### **Option #2 – Exemption**

Pursuant to Public Contract Code sections 2203(c) and (d), a public entity may permit a Contractor/financial institution engaged in investment activities in Iran, on a case-by-case basis, to be eligible for, or to bid on, submit a proposal for, or enters into or renews, a contract for goods and services.

**If you have obtained an exemption** from the certification requirement under the Iran Contracting Act, please fill out the information below, and **attach documentation demonstrating the exemption approval.**

<i>Contractor Name/Financial Institution (Printed)</i> <b>N/A</b>		<i>Federal ID Number (or n/a)</i> <b>N/A</b>
<i>By (Authorized Signature)</i> <b>N/A</b>		
<i>Printed Name and Title of Person Signing</i> <b>N/A</b>		
<i>Date Executed</i> <b>N/A</b>	<i>Executed in</i> <b>N/A</b>	

N/A

**Opt Out of Payment Adjustments for Price Index Fluctuations**

**Johnston Avenue Resurfacing  
San Jacinto Street to 630-Foot East of Stanford Street  
Community of East Hemet  
Project No. B0-0612**

To opt out of the payment adjustments for price index fluctuations, as specified in Standard Specifications Section 9-1.07 "Payment Adjustments for Price Index Fluctuations," completely fill in, date, sign, and submit this form with the Bid documents.

By signing and submitting this form, our company hereby opts out of the payment adjustments for price index fluctuations for the above-named project.

Date: \_\_\_\_\_

Company Name (Bidder): \_\_\_\_\_

Signature: \_\_\_\_\_

(Signature of Company's authorized officer or designated representative)

Name (printed): \_\_\_\_\_

Title: \_\_\_\_\_

**Bid Bond**

**Recitals:**

1. Onyx Paving Company, Inc. "Contractor", has submitted his/her Contractor's Proposal to County of Riverside, "County", for the construction of public work for Johnston Avenue Resurfacing, San Jacinto Street to 630-Foot East of Stanford Street, Community of East Hemet, Project No. B0-0612 in accordance with a Notice Inviting Bids from the County.
2. United Fire & Casualty Company an Iowa corporation, hereafter called "Surety", is the surety of this bond.

**Agreement:**

We, Contractor as Principal and Surety as Surety, jointly and severally agree and state as follows:

1. The amount of the obligation of this bond is 10% of the amount of the Contractor's Proposal, including bid alternates, and inures to the benefit of County.
2. This Bond is exonerated by (1) County rejecting said Proposal or, in the alternate, (2) if said Proposal is accepted, Contractor executes the Contract and furnishes the Bonds as agreed to in its Proposal, otherwise it remains in full force and effect for the recovery of loss, damage and expense of County resulting from failure of Contractor to act as agreed to in its Proposal. Some types of possible loss, damage and expense are specified in the Contractor's Proposal.
3. Surety, for value received, stipulates and agrees that its obligations hereunder shall in no way be impaired or affected by any extension of time within which County may accept the Proposal and waives notice of any such extension.
4. This Bond is binding on our heirs, executors, administrators, successors and assigns.

Dated: June 30th, 2023

Signatures:

United Fire & Casualty Company

By:

*Christina Rogers*

Title:

Christina Rogers,  
Attorney in Fact  
"Surety"



Onyx Paving Company, Inc.

By:

*[Signature]*

Title:

Corey R. Kirschner - CEO, Pres.  
"Contractor"



STATE OF \_\_\_\_\_  
COUNTY \_\_\_\_\_  
OF \_\_\_\_\_

} ss. SURETY'S ACKNOWLEDGEMENT

On \_\_\_\_\_ before me, \_\_\_\_\_ personally appeared, \_\_\_\_\_ known to me, or proved to me on the basis of satisfactory evidence, to be the person whose name is subscribed to the within instrument and acknowledged to me that he/she executed the same in his/her authorized capacities, and that by his/her signature on the instrument the person, or the entity upon behalf of which the person acted, executed the instrument.

WITNESS my hand and official seal.

\*See Attached Required California All-Purpose Acknowledgment\*

Signature of Notary Public

Notary Public (Seal)

**Note: This Bond must be executed by both Contractor and Surety with corporate seal affixed. All signatures must be notarized. (Attach acknowledgements).**

**CALIFORNIA ALL-PURPOSE ACKNOWLEDGMENT**

**CIVIL CODE § 1189**

A notary public or other officer completing this certificate verifies only the identity of the individual who signed the document to which this certificate is attached, and not the truthfulness, accuracy, or validity of that document.

State of California )  
County of Orange )

On June 30, 2023 before me, Carly Bredal, Notary Public  
Date Here Insert Name and Title of the Officer

personally appeared Corey R. Kirschner  
Name(s) of Signer(s)

who proved to me on the basis of satisfactory evidence to be the person(x) whose name(s) is/are subscribed to the within instrument and acknowledged to me that he/she/they executed the same in his/her/their authorized capacity(ies), and that by his/her/their signature(s) on the instrument the person(s), or the entity upon behalf of which the person(s) acted, executed the instrument.

I certify under PENALTY OF PERJURY under the laws of the State of California that the foregoing paragraph is true and correct.

WITNESS my hand and official seal.



Signature Carly Bredal  
Signature of Notary Public

Place Notary Seal Above

**OPTIONAL**

Though this section is optional, completing this information can deter alteration of the document or fraudulent reattachment of this form to an unintended document.

**Description of Attached Document**

Title or Type of Document: \_\_\_\_\_ Document Date: \_\_\_\_\_  
Number of Pages: \_\_\_\_\_ Signer(s) Other Than Named Above: \_\_\_\_\_

**Capacity(ies) Claimed by Signer(s)**

Signer's Name: \_\_\_\_\_  
 Corporate Officer — Title(s): \_\_\_\_\_  
 Partner —  Limited  General  
 Individual  Attorney in Fact  
 Trustee  Guardian or Conservator  
 Other: \_\_\_\_\_  
Signer Is Representing: \_\_\_\_\_

Signer's Name: \_\_\_\_\_  
 Corporate Officer — Title(s): \_\_\_\_\_  
 Partner —  Limited  General  
 Individual  Attorney in Fact  
 Trustee  Guardian or Conservator  
 Other: \_\_\_\_\_  
Signer Is Representing: \_\_\_\_\_

CALIFORNIA ALL-PURPOSE ACKNOWLEDGEMENT

A Notary Public or other officer completing this certificate verifies only the identity of the individual who signed the document to which this certificate is attached, and not the truthfulness, accuracy, or validity of that document.

State of California }  
County of Orange }

On JUN 3 0 2023, before me, Albert Melendez, Notary Public,  
personally appeared Christina Rogers

who proved to me on the basis of satisfactory evidence to be the person(x) whose name(x) is/~~are~~  
subscribed to the within instrument and acknowledged to me that ~~he~~/she/~~they~~ executed the same  
in ~~his~~/her/~~their~~ authorized capacity(~~ies~~), and that by ~~his~~/her/~~their~~ signature(~~s~~) on the instrument  
the person(x), or the entity upon behalf of which the person(x) acted, executed the instrument.

I certify under PENALTY OF PERJURY under the laws of State of California that the foregoing  
paragraph is true and correct.

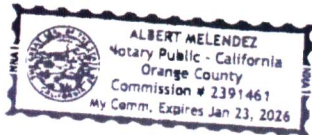

WITNESS my hand and official seal.

SIGNATURE 

PLACE NOTARY SEAL ABOVE

Though the information below is not required by law, it may prove valuable to persons relying on the document  
and could prevent fraudulent removal and reattachment of this form to another document.

**Description of attached document**

Title or type of document: \_\_\_\_\_

\_\_\_\_\_  
\_\_\_\_\_

Document Date: \_\_\_\_\_ Number of Pages: \_\_\_\_\_

Signer(s) Other than Named Above: \_\_\_\_\_



UNITED FIRE & CASUALTY COMPANY, CEDAR RAPIDS, IA  
 UNITED FIRE & INDEMNITY COMPANY, WEBSTER, TX  
 FINANCIAL PACIFIC INSURANCE COMPANY, LOS ANGELES, CA  
 CERTIFIED COPY OF POWER OF ATTORNEY  
 (original on file at Home Office of Company – See Certification)

Inquiries: Surety Department  
 118 Second Ave SE  
 Cedar Rapids, IA 52401

KNOW ALL PERSONS BY THESE PRESENTS, That United Fire & Casualty Company, a corporation duly organized and existing under the laws of the State of Iowa; United Fire & Indemnity Company, a corporation duly organized and existing under the laws of the State of Texas; and Financial Pacific Insurance Company, a corporation duly organized and existing under the laws of the State of California (herein collectively called the Companies), and having their corporate headquarters in Cedar Rapids, State of Iowa, does make, constitute and appoint

ERIK JOHANSSON, JOAQUIN PEREZ, ALBERT MELENDEZ, JENNIFER ANAYA, MELISSA LOPEZ, CHRISTINA ROGERS,  
 EACH INDIVIDUALLY

their true and lawful Attorney(s)-in-Fact with power and authority hereby conferred to sign, seal and execute in its behalf all lawful bonds, undertakings and other obligatory instruments of similar nature provided that no single obligation shall exceed \$25,000,000.00 and to bind the Companies thereby as fully and to the same extent as if such instruments were signed by the duly authorized officers of the Companies and all of the acts of said Attorney, pursuant to the authority hereby given and hereby ratified and confirmed.

The Authority hereby granted shall expire the 24th day of August, 2024 unless sooner revoked by United Fire & Casualty Company, United Fire & Indemnity Company, and Financial Pacific Insurance Company.

This Power of Attorney is made and executed pursuant to and by authority of the following bylaw duly adopted by the Boards of Directors of United Fire & Casualty Company, United Fire & Indemnity Company, and Financial Pacific Insurance Company.

**“Article VI – Surety Bonds and Undertakings”**

Section 2, Appointment of Attorney-in-Fact. “The President or any Vice President, or any other officer of the Companies may, from time to time, appoint by written certificates attorneys-in-fact to act in behalf of the Companies in the execution of policies of insurance, bonds, undertakings and other obligatory instruments of like nature. The signature of any officer authorized hereby, and the Corporate seal, may be affixed by facsimile to any power of attorney or special power of attorney or certification of either authorized hereby: such signature and seal, when so used, being adopted by the Companies as the original signature of such officer and the original seal of the Companies, to be valid and binding upon the Companies with the same force and effect as though manually affixed. Such attorneys-in-fact, subject to the limitations set of forth in their respective certificates of authority shall have full power to bind the Companies by their signature and execution of any such instruments and to attach the seal the Companies thereto. The President or any Vice President, the Board of Directors or any other officer of the Companies may at any time revoke all power and authority previously given to any attorney-in-fact.

IN WITNESS WHEREOF, the COMPANIES have each caused these presents to be signed by its vice president and its corporate seal to be hereto affixed this

24th day of August, 2022



UNITED FIRE & CASUALTY COMPANY  
 UNITED FIRE & INDEMNITY COMPANY  
 FINANCIAL PACIFIC INSURANCE COMPANY

By: *Dennis J. Richmann*  
 Vice President

State of Iowa, County of Linn, ss:

On 24th day of August, 2022, before me personally came Dennis J. Richmann

to me known, who being by me duly sworn, did depose and say; that he resides in Cedar Rapids, State of Iowa; that he is a Vice President of United Fire & Casualty Company, a Vice President of United Fire & Indemnity Company, and a Vice President of Financial Pacific Insurance Company the corporations described in and which executed the above instrument; that he knows the seal of said corporations; that the seal affixed to the said instrument is such corporate seal; that it was so affixed pursuant to authority given by the Board of Directors of said corporations and that he signed his name thereto pursuant to like authority, and acknowledges same to be the act and deed of said corporations.

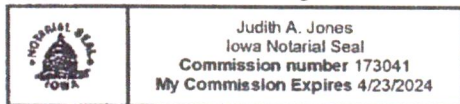

*Judith A. Jones*  
 Notary Public  
 My commission expires: 4/23/2024

I, Mary A. Bertsch, Assistant Secretary of United Fire & Casualty Company and Assistant Secretary of United Fire & Indemnity Company, and Assistant Secretary of Financial Pacific Insurance Company, do hereby certify that I have compared the foregoing copy of the Power of Attorney and affidavit, and the copy of the Section of the bylaws and resolutions of said Corporations as set forth in said Power of Attorney, with the ORIGINALS ON FILE IN THE HOME OFFICE OF SAID CORPORATIONS, and that the same are correct transcripts thereof, and of the whole of the said originals, and that the said Power of Attorney has not been revoked and is now in full force and effect.

In testimony whereof I have hereunto subscribed my name and affixed the corporate seal of the said Corporations  
 this 30th day of June, 2023.



By: *Mary A. Bertsch*  
 Assistant Secretary,  
 UF&C & UF&I & FPIC

- Company Profile
- Company Search
- Company Search Results
- Company Information
- Old Company Names
- Agent for Service Reference Information
- NAIC Group List
- Lines of Business
- Workers' Compensation Complaint and Request for Action/Appeals Contact Information
- Financial Statements PDF's
- Annual Statements
- Quarterly Statements
- Company Complaint
- Company Performance & Comparison Data
- Company Enforcement Action
- Composite Complaints Studies
- Additional Info
- Find A Company Representative In Your Area
- View Financial Disclaimer

**COMPANY PROFILE**

**Company Information**

**UNITED FIRE & CASUALTY COMPANY**  
**PO BOX 73909**  
**CEDAR RAPIDS, IA 52407-3909**

**Old Company Names**

**Effective Date**

**Agent For Service**

AMANDA GARCIA  
 330 N Brand Blvd Ste 700  
 Glendale CA 91203

**Reference Information**

NAIC #:	13021
California Company ID #:	2416-6
Date Authorized in California:	02/11/1981
License Status:	UNLIMITED-NORMAL
Company Type:	Property & Casualty
State of Domicile:	IOWA

[back to top](#)

**NAIC Group List**

NAIC Group #: **0248** UNITED FIRE & CAS GRP

**Lines Of Business**

The company is authorized to transact business within these lines of insurance. For an explanation of any of these terms, please refer to the [glossary](#).

- AUTOMOBILE
- BOILER AND MACHINERY
- BURGLARY
- COMMON CARRIER LIABILITY
- FIRE
- LIABILITY
- MARINE
- MISCELLANEOUS
- PLATE GLASS
- SPRINKLER
- SURETY
- TEAM AND VEHICLE
- WORKERS' COMPENSATION



United Fire & Casualty Company  
United Fire & Indemnity Company  
Financial Pacific Insurance Company

SURETY

## SURETY BOND SEAL ADDENDUM

United Fire & Casualty Company  
PO Box 73909  
Cedar Rapids, Iowa 52407

United Fire & Casualty Company has authorized its Attorneys-in-Fact to affix United Fire & Casualty Company corporate seal to any bond executed on behalf of United Fire & Casualty Company by any such Attorney-in-Fact by attaching this Addendum to said bond.

To the extent this Addendum is attached to a bond that is executed on behalf of United Fire & Casualty Company by its Attorney-in-Fact, United Fire & Casualty Company hereby agrees that the seal below shall be deemed affixed to said bond to the same extent as if its raised corporate seal was physically affixed to the face of the bond.

Dated this 30th day of June, 2023.

United Fire & Casualty Company



By: *Dennis J. Richmann*  
Dennis J. Richmann, Vice President



STATE OF CALIFORNIA  
DEPARTMENT OF INSURANCE  
SAN FRANCISCO

Amended  
**Certificate of Authority**

THIS IS TO CERTIFY that, pursuant to the Insurance Code of the State of California,

**United Fire & Casualty Company**

of Iowa, organized under the laws of Iowa, subject to its Articles of Incorporation or other fundamental organizational documents, is hereby authorized to transact within this State, subject to all provisions of this Certificate, the following classes of insurance:

**Fire, Marine, Surety, Plate Glass, Liability, Workers' Compensation,  
Common Carrier Liability, Boiler and Machinery, Burglary,  
Sprinkler, Team and Vehicle, Automobile, and Miscellaneous**

as such classes are now or may hereafter be defined in the Insurance Laws of the State of California.

THIS CERTIFICATE is expressly conditioned upon the holder hereof now and hereafter being in full compliance with all, and not in violation of any, of the applicable laws and lawful requirements made under authority of the laws of the State of California as long as such laws or requirements are in effect and applicable, and as such laws and requirements now are, or may hereafter be changed or amended.

IN WITNESS WHEREOF, effective as of the 16<sup>th</sup> day of July, 2014,  
I have hereunto set my hand and caused my official seal to be affixed  
this 16<sup>th</sup> day of July, 2014.



Dave Jones  
Insurance Commissioner

By

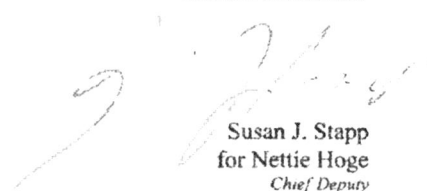
  
Susan J. Stapp  
for Nettie Hoge  
Chief Deputy

**NOTICE:**

Qualification with the Secretary of State must be accomplished as required by the California Corporations Code promptly after issuance of this Certificate of Authority. Failure to do so will be a violation of Insurance Code section 701 and will be grounds for revoking this Certificate of Authority pursuant to the covenants made in the application therefor and the conditions contained herein.



### REFERENCES

**PROJECT NAME:** CITYWIDE ASPHALT REPAIRS PROJECT FY 21/22

**PROJECT DESCRIPTION:** CITYWIDE STREET IMPROVEMENTS

**APPROXIMATE CONSTRUCTION DATES:** FEB 2022 - NOV 2022

**CONSULTING COMPANY:** CITY OF DANA POINT - 33282 GOLDEN LANTERN, DANA POINT, CA 92629

**CONTACT PERSON:** SCOTT FISHER 760-814-7226

**ORIGINAL CONTRACT AMOUNT:** \$1,595,000.00

**FINAL CONTRACT AMOUNT:** \$1,314,878.59

**IF FINAL AMOUNT IS DIFFERENT FROM ORIGINAL AMOUNT, PLEASE EXPLAIN:** FIELD QUANTITIES DIFFERED FROM BID SCHEDULE QUANTITIES

**DID THE AGENCY FILE ANY CLAIMS AGAINST YOU?** NO

**PROJECT NAME:** PALISADES PAVEMENT REPAIR, CC-07

**PROJECT DESCRIPTION:** PAVEMENT REPAIR

**APPROXIMATE CONSTRUCTION DATES:** SEP 2022

**AGENCY:** CITY OF LAGUNA NIGUEL - 30111 CROWN VALLEY PARKWAY, LAGUNA NIGUEL, CA 92677

**CONTACT PERSON:** JEFF METZ 949-362-4344

**ORIGINAL CONTRACT AMOUNT:** \$292,000.00

**FINAL CONTRACT AMOUNT:** \$199,999.65

**IF FINAL AMOUNT IS DIFFERENT FROM ORIGINAL AMOUNT, PLEASE EXPLAIN:** FIELD QUANTITIES DIFFERED FROM BID SCHEDULE QUANTITIES.

**DID THE AGENCY FILE ANY CLAIMS AGAINST YOU?** NO

**PROJECT NAME:** 2021-2022 PAVEMENT REHABILITATION PROJECT

**PROJECT DESCRIPTION:** VARIOUS PAVEMENT REHABILITATION & CONCRETE IMPROVEMENTS

**APPROXIMATE CONSTRUCTION DATES:** NOV 2022 - MARCH 2023

**AGENCY:** CITY OF ARCADIA -240 W. HUNTINGTON DR, ARCADIA, CA 91007

**CONTACT PERSON:** JAN BALANAY 626-254-2726

**ORIGINAL CONTRACT AMOUNT:** \$1,727,000.00

**FINAL CONTRACT AMOUNT:** \$1,899,698.72

**IF FINAL AMOUNT IS DIFFERENT FROM ORIGINAL AMOUNT, PLEASE EXPLAIN:** AGENCY HAD ADDITIONAL SCOPES OF WORK.

**DID THE AGENCY FILE ANY CLAIMS AGAINST YOU?** NO

ONYX PAVING COMPANY, INC.  
2890 EAST LA CRESTA AVE, ANAHEIM, CA 92806 -- TEL (714) 632-6699 --FAX (714) 632-1883



**PROJECT NAME:** 2020 RESIDENTIAL STREET REHABILITATION PROJECT

**PROJECT DESCRIPTION:** CITYWIDE STREET IMPROVEMENTS

**APPROXIMATE CONSTRUCTION DATES:** JULY 2021 - NOV 2021

**AGENCY:** CITY OF SOUTH EL MONTE - 1415 SANTA ANITA AVE, SOUTH EL MONTE, CA 91733

**CONTACT PERSON:** OKAN DEMIRCI - 714-319-6137

**ORIGINAL CONTRACT AMOUNT:** \$614,000.00

**FINAL CONTRACT AMOUNT:** \$706,010.03

**IF FINAL AMOUNT IS DIFFERENT FROM ORIGINAL AMOUNT, PLEASE EXPLAIN:** SCOPES OF WORK ADDED BY

AGENCY

**DID THE AGENCY FILE ANY CLAIMS AGAINST YOU?** NO

**PROJECT NAME:** RESIDENTIAL STREET PAVEMENT REHABILITATION PROJECT, AREA 8

**PROJECT DESCRIPTION:** STREET IMPROVEMENTS

**APPROXIMATE CONSTRUCTION DATES:** JULY 2022 – OCT 2022

**AGENCY:** CITY OF DOWNEY – 11111 BROOKSHIRE AVE, DOWNEY, CA 90241

**CONTACT PERSON:** DESI GUTIERREZ 562-622-3468

**ORIGINAL CONTRACT AMOUNT:** \$3,227,00.00

**FINAL CONTRACT AMOUNT:** \$3,553,442.43

**IF FINAL AMOUNT IS DIFFERENT FROM ORIGINAL AMOUNT, PLEASE EXPLAIN:** FIELD QUANTITIES DIFFERED FROM

BID SCHEDULE QUANTITIES

**DID THE AGENCY FILE ANY CLAIMS AGAINST YOU?** NO

**PROJECT NAME:** SOBOBA STREET RESURFACING PROJECT

**PROJECT DESCRIPTION:** STREET REHABILITATION AND RECONSTRUCTION

**APPROXIMATE CONSTRUCTION DATES:** AUG 2022 – OCT 2022

**AGENCY:** RIVERSIDE COUNTY TRANSPORTATION DEPARTMENT – 3525 14<sup>TH</sup> STREET, RIVERSIDE, CA 92507 CONTACT

**PERSON:** TRAI NGUYEN 951-961-5363

**ORIGINAL CONTRACT AMOUNT:** \$ 1,272,000.00

**FINAL CONTRACT AMOUNT:** \$1,160,284.10

**IF FINAL AMOUNT IS DIFFERENT FROM ORIGINAL AMOUNT, PLEASE EXPLAIN:** FIELD QUANTITIES DIFFERED FROM

BID SCHEDULE QUANTITIES

**DID THE AGENCY FILE ANY CLAIMS AGAINST YOU?** NO

ONYX PAVING COMPANY, INC.  
2890 EAST LA CRESTA AVE, ANAHEIM, CA 92806 – TEL (714) 632-6699 – FAX (714) 632-1883



**PROJECT NAME:** 2019/20 ARTERIAL AND MINOR STREETS MAINTENANCE PHASE 2

**PROJECT DESCRIPTION:** CITYWIDE STREET IMPROVEMENTS

**APPROXIMATE CONSTRUCTION DATES:** DEC 2021 – NOV 2022

**AGENCY:** CITY OF RIVERSIDE – 3900 MAIN ST, RIVERSIDE, CA 92501

**CONTACT PERSON:** STEVEN HOWARD 951-826-5311

**ORIGINAL CONTRACT AMOUNT:** \$4,585,000.00

**FINAL CONTRACT AMOUNT:** \$4,558,151.40

**IF FINAL AMOUNT IS DIFFERENT FROM ORIGINAL AMOUNT, PLEASE EXPLAIN:** FIELD QUANTITIES DIFFERED FROM BID

**SCHEDULE QUANTITIES**

**DID THE AGENCY FILE ANY CLAIMS AGAINST YOU?** NO

**PROJECT NAME:** FY 2021-22 ANNUAL ROADWAY REHABILITATION AND SIDEWALK REPAIR

**PROJECT DESCRIPTION:** VARIOUS STREET IMPROVEMENTS

**APPROXIMATE CONSTRUCTION DATES:** JUNE 2022 - SEP 2022

**AGENCY:** CITY OF TUSTIN - 300 CENTENNIAL WAY, TUSTIN, CA 92780

**CONTACT PERSON:** JOANN WU 714-573-3157

**ORIGINAL CONTRACT AMOUNT:** \$2,442,000.00

**FINAL CONTRACT AMOUNT:** \$2,413,734.93

**IF FINAL AMOUNT IS DIFFERENT FROM ORIGINAL AMOUNT, PLEASE EXPLAIN:** FIELD QUANTITIES DIFFERED FROM

**BID SCHEDULE QUANTITIES.**

**DID THE AGENCY FILE ANY CLAIMS AGAINST YOU?** NO



ONYX PAVING COMPANY, INC.  
2890 EAST LA CRESTA AVE, ANAHEIM, CA 92806 – TEL (714) 632-6699 – FAX (714) 632-1883



**LARGE PROJECT REFERENCES**

**PROJECT NAME: CULVER DRIVE IMPROVEMENTS FROM WALNUT AVENUE TO I-5 FREEWAY**

**PROJECT DESCRIPTION: STREET IMPROVEMENTS**

**APPROXIMATE CONSTRUCTION DATES: SEPT 2022 – JAN 2023**

**CONSULTING COMPANY: CITY OF IRVINE - 6427 OAK CANYON, IRVINE, CA 92618**

**CONTACT PERSON: FARHAD BOLOURCHI 949-724-6689**

**ORIGINAL CONTRACT AMOUNT: \$1,677,000.00**

**FINAL CONTRACT AMOUNT: \$1,704,308.59**

**IF FINAL AMOUNT IS DIFFERENT FROM ORIGINAL AMOUNT, PLEASE EXPLAIN: FIELD QUANTITIES DIFFERED FROM BID SCHEDULE QUANTITIES**

**DID THE AGENCY FILE ANY CLAIMS AGAINST YOU? NO**

**PROJECT NAME: PHASING 6A - RESIDENTIAL STREET REHABILITATION**

**PROJECT DESCRIPTION: STREET IMPROVEMENTS**

**APPROXIMATE CONSTRUCTION DATES:**

**CONSULTING COMPANY: CITY OF LA MIRADA - 15515 PHOEBE AVE, LA MIRADA, CA 90638**

**CONTACT PERSON: ERIC VILLAGRACIA 562-902-2373**

**ORIGINAL CONTRACT AMOUNT: \$4,242,000.00**

**FINAL CONTRACT AMOUNT: \$4,524,646.67**

**IF FINAL AMOUNT IS DIFFERENT FROM ORIGINAL AMOUNT, PLEASE EXPLAIN: SCOPES OF WORK CHANGED BY AGENCY**

**DID THE AGENCY FILE ANY CLAIMS AGAINST YOU? NO**

**PROJECT NAME: ROCHESTER AVENUE PAVEMENT REHABILITATION**

**PROJECT DESCRIPTION: STREET IMPROVEMENTS**

**APPROXIMATE CONSTRUCTION DATES: MARCH 2022-AUG 2022**

**AGENCY: CITY OF RANCHO CUCAMONGA - 10500 CIVIC CENTER DRIVE, RANCHO CUCAMONGA, CA 91730**

**CONTACT PERSON: ROMEO DAVID 909-774-4070**

**ORIGINAL CONTRACT AMOUNT: \$1,727,000.00**

**FINAL CONTRACT AMOUNT: \$1,714,733.75**

**IF FINAL AMOUNT IS DIFFERENT FROM ORIGINAL AMOUNT, PLEASE EXPLAIN: FIELD QUANTITIES DIFFERED FROM BID SCHEDULE QUANTITIES**

**DID THE AGENCY FILE ANY CLAIMS AGAINST YOU? NO**

**ONYX PAVING COMPANY, INC.  
2890 EAST LA CRESTA AVE, ANAHEIM, CA 92806 – TEL (714) 632-6699 – FAX (714) 632-1883**



### REFERENCES

<u>GENERAL CONTRACTORS:</u>	<u>JOBS PERFORMED:</u>	<u>LOCATION:</u>	<u>AMOUNT:</u>
<b>Fullmer Construction</b>	<b>Centerpointe</b>	Moreno Valley	\$3,187,914.00
1725 S. Grove Ave.	<b>Sycamore Bus. Park</b>	Riverside	\$999,708.00
Ontario, CA 91761	<b>Hillwood Hofer Ranch</b>	Ontario	\$603,600.00
Ph: 909-947-9467	<b>Interchange A-E</b>	San Bernardino	\$1,288,615.00
Fax: 909-947-2970	<b>San Michelle Logistics</b>	Moreno Valley	\$670,674.00
Contact: Casey Jones	<b>Terra Francesco</b>	Ontario	\$524,216.00
<b>KCS West, Inc.</b>	<b>BP Refinery Maintenance Shop</b>	Carson	\$896,357.00
901 Corporate Ctr, Dr, 3 <sup>rd</sup> flr			
Monterey Park, CA 9174			
Ph: 323-269-0020			
Fx: 323-263-4576			
Contact: Matthew Vawter			
<b>GMC Engineering, Inc.</b>	<b>Edison</b>	Romoland	\$1,623,480.00
1401 Warner Ave			
Tustin, CA 92780			
Ph: 760-744-133			
Fx: 714-247-1041			
Contact: Gennady			
<b>Lusardi Construction</b>	<b>FEDEX – Otay Mesa</b>	San Diego	\$1,335,530.00
1570 Linda Vista Dr.	<b>Team Nissan</b>	Oxnard	\$669,075.00
San Marcos, CA 92064	<b>Edge at Campus</b>	El Segundo	\$541,385.00
Ph: 760-744-3133	<b>Carmax</b>	Oxnard	\$606,443.00
Fax: 760-744-9064	<b>Seabridge</b>	Oxnard	\$329,460.00
Contact Scott Staley			

ONYX PAVING COMPANY, INC.

2890 EAST LA CRESTA AVE, ANAHEIM, CA 92806 – TEL (714) 632-6699 – FAX (714) 632-1883



<b>Haagen Company, LLC</b> 12302 Exposition Blvd Los Angeles, CA 90064 Ph: 310-820-1200 Fx: 310-820-1225 Contact: Chris Fahey	<b>Empire Polo Club</b>	Indio	\$1,036,745.00
<b>ARCO National Construction Co.</b> 900 N. Rock Hill Rd St. Louis, MO 63119 Ph: 314-963-0715 Fx: 314-963-7114 Contact: Chris Wilson	<b>Scannell FEDEX</b>	Burbank	\$1,125,958.00
<b>Grant General Contractors</b> 5051 Avenida Encinas Carlsbad, CA 92008 Ph: 760-438-7500 Fx: 760-438-3056 Contact: Pete Burrows	<b>Whittier Area Community Church</b> <b>Crevler BMW</b>	Whittier  Santa Ana	\$625,920.00  \$30,600.00



**ASPHALT RUBBER HOT MIX REFERENCES:**

<u>GENERAL CONTRACTORS:</u>	<u>JOBS PERFORMED:</u>	<u>LOCATION:</u>	<u>AMOUNT:</u>
<b>GMC ENGINEERING, INC.</b> 1401 Warner Ave, Ste B. Tustin, CA 92780 Ph: 714-247-1040 Fx: 714-247-1041 Contact: Gennady Chizik	<b>Katella Ave. St. Improv</b> Various Projects	Los Alamitos	\$120,000.00
<b>R.D OLSON CONSTRUCITON, INC.</b> 2955 Main Street, 3 <sup>rd</sup> Floor Irvine, CA 92614 Ph: 949-474-2001 Fx: 949-474-1534 Contact: Jeremy Dunn	<b>Lido House Hotel</b>	Newport Beach	\$193,105.00

*IF YOU HAVE ANY QUESTIONS, PLEASE FEEL FREE TO CONTACT COREY KIRSCHNER AT 714-632-6699 OR VIA EMAIL AT [COREY@ONYXPAVING.NET](mailto:COREY@ONYXPAVING.NET)*





## CREDIT REFERENCES

### **ONYX PAVING COMPANY, INC**

2890 E. LA CRESTA AVE  
ANAHEIM, CA 92806

PHONE: (714) 632-6699

DATE ESTABLISHED 1/4/90

CORP. TAX ID. # 33-0394344

FAX: (714) 632-1883

TYPE OF WORK - ASPHALT PAVING

CONTRACTORS LIC. # 630360-A

PRESIDENT: COREY R. KIRSCHNER

14029 SPRINGWATER LN. EASTVALE, CA 92880

BANK: BANK OF THE WEST

4501 E. LA PALMA AVENUE, ANAHEIM, CA 92807

PHONE: (714) 777-9620 BRYAN PLOESSEL

INSURANCE AGENT: WOOD GUTMANN & BOGART

15901 RED HILL AVE., STE. 100, TUSTIN, CA 92780

PHONE: (714) 824-8384 MICHAEL TRAN

SURETY AGENT:

TURNER SURETY AND INSURANCE BROKERAGE, INC.

5 HUTTON CENTRE, STE. 730, SANTA ANA, CA 92707

PHONE: (714) 915-4032 JEREMY PENDERGAST

### CREDIT REFERENCES:

MATICH CORP.	P.O. BOX 10, HIGHLAND, CA 92346	(909) 382-7400 Steve Matich
ALL AMERICAN	P.O. BOX 2229, CORONA, CA 92878	(951) 736-7600 Carl
KELTERITE CORP.	12231 PANGBORN AVE. DOWNEY, CA	(562) 401-0011 Gladys
VULCAN MATERIALS CO.	16013 E. FOOTHILL BLVD, IRWINDALE, CA 91702	(858) 530-9414 Debble

### GENERAL CONTRACTOR REFERENCES:

FULLMER CONSTRUCTION	1725 S. GROVE AVE., ONTARIO, CA 91761	(909) 947-9467 Casey Jones
BYROM-DAVEY, INC.	13220 EVENING CREEK DR. SOUTH #103, SAN DIEGO	(858) 513-7199 Steve Davey
PACIFIC CONST. GROUP	17895 SKY PARK CIR., IRVINE, CA 92614	(949) 748-1500 Mark Bundy
ERICKSON-HALL CONST. CO.	500 CORPORATE DR., ESCONDIDO, CA 92069	(760) 796-7700 Justin Sinnott

ONYX PAVING COMPANY, INC.  
2890 EAST LA CRESTA AVE, ANAHEIM, CA 92806 – TEL (714) 632-6699 – FAX (714) 632-1883



ERICKSON-HALL CONST. CO.

500 CORPORATE DR., ESCONDIDO, CA 92069

(760) 796-7700 **Justin Sinnott**

## **RESUME**

Corey Kirschner has over 20 years of experience both as an estimator and CEO. Corey is an experienced estimator and lead a majority of those years being the Chief Estimator before becoming CEO and President of Onyx Paving Company, Inc. Over the short period of time here at Onyx Paving, Corey has completed over 3,000 paving projects, allowing the company to gross over \$50 million dollars in the previous year.

Jay Kirschner, Senior Project Manager, holds a Bachelor's Degree from Chapman University and has 7 years of experience upholding the maintenance supervisor and lead estimator position for Onyx Paving. He leads our team, with the project managers under his direct supervision, in managing our productions and coordinating our field mobilizations for all projects.

Tyler Henry, Field Superintendent, serves as the core of all field related matters. He has over 20 years of paving experience performing jobs that stretches from San Diego County to Ventura County. Tyler has been with Onyx in completing all of our Public Works projects. Overseeing the on-site laborers, cement masons, and operating engineers is one of his many responsibilities.

### **BACKLOG ALLOCATION:**

Corey Kirschner, Jay Kirschner, and Tyler Henry oversee 100% of all current project in attached backlog.

**ONYX PAVING COMPANY, INC.**

2890 EAST LA CRESTA AVE, ANAHEIM, CA 92806 – TEL (714) 632-6699 – FAX (714) 632-1883

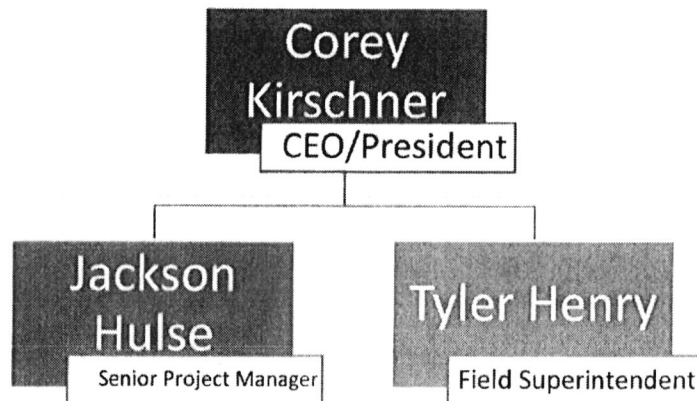

### **Key Individual Responsibilities:**

#### Corey Kirschner

- Manage overall operations and resources of company
- Decision maker of corporation

#### Jackson Hulse

- Lead project management team with organization
- Overseeing overall project scheduling, budgeting, and dispatching on all projects
- Main point of communications between company and agencies

#### Tyler Henry

- Lead and manage on-site labors and operators
- Coordinate daily operations and project production
- Ensuring project quality expectations are met

STATE OF CALIFORNIA



# CONTRACTORS STATE LICENSE BOARD

Pursuant to Chapter 9 of Division 3 of the Business and Professions Code  
and the Rules and Regulations of the Contractors State License Board,  
the Registrar of Contractors does hereby issue this license to:

**ONYX PAVING COMPANY INC**

**License Number 630360**

to engage in the business or act in the capacity of a contractor in the following classifications:

A- GENERAL ENGINEERING CONTRACTOR  
C12 - EARTHWORK AND PAVING

Witness my hand and seal this day,

January 4, 2019

**Issued October 9, 1991**

  
Marlo Richardson, Board Chair

This license is the property of the Registrar of Contractors,  
is not transferable, and shall be returned to the Registrar  
upon demand when suspended, revoked, or invalidated  
for any reason. It becomes void if not renewed.

  
David R. Fogt, Registrar of Contractors



CONTRACTORS  
STATE LICENSE BOARD  
ACTIVE LICENSE



License Number **630360**

Entity CORP

Business Name ONYX PAVING COMPANY INC

Classifications A C12

Expiration Date 10/31/2023

[www.cslb.ca.gov](http://www.cslb.ca.gov)



Contractor Information

**Legal Entity Name**  
 ONYX PAVING COMPANY, INC.  
**Legal Entity Type**  
 Corporation  
**Status**  
 Active  
**Registration Number**  
 1000004798  
**Registration effective date**  
 7/1/2022  
**Registration expiration date**  
 6/30/2023  
**Mailing Address**  
 2890 E. LA CRESTA AVENUE ANAHEIM 92806 CA United States of America  
**Physical Address**  
 2890 E. LA CRESTA AVENUE ANAHEIM 92806 CA United States of America  
**Email Address**  
**Trade Name/DBA**  
**License Number(s)**  
 CSLB.630360

Registration History

Effective Date	Expiration Date
6/25/2018	6/30/2019
5/8/2017	6/30/2018
5/25/2016	6/30/2017
6/10/2015	6/30/2016
1/6/2015	6/30/2015
7/1/2019	6/30/2022
7/1/2022	6/30/2023

Legal Entity Information

**Corporation Number:**  
**Federal Employment Identification Number:**  
**President Name:** Corey Kirschner  
**Vice President Name:**  
**Treasurer Name:**  
**Secretary Name:**  
**CEO Name:**  
**Agent of Service Name:** Corey Kirschner  
**Agent of Service Mailing Address:** 2890 E La Cresta Ave. Anaheim 92806 CA United States of America

Workers Compensation

Do you lease employees through Professional Employer Organization (PEO)? No  
 Please provide your current workers compensation insurance information below:

PEO InformationName	PEO Phone	PEO Email

**Insured by Carrier**  
**Policy Holder Name:** ONYX PAVING COMPANY, INC.  
**Insurance Carrier:** ZURICH AMERICAN INSURANCE COMPANY  
**Policy Number:** WC106300503  
**Inception date:** 10/1/2021  
**Expiration Date:** 10/1/2022



ONYX PAVING COMPANY, INC.  
License # 630360 -- DIR # 1000004798

**UNANIMOUS WRITTEN CONSENT OF  
THE BOARD OF DIRECTORS OF  
ONYX PAVING COMPANY, INC.  
(a California corporation)**

October 28, 2020

The undersigned director, constituting the entire board of directors (the "Board") of Onyx Paving Company, Inc., a California corporation (the "Corporation"), hereby takes the following actions, adopts the following resolutions, and transacts the following business, by written consent without a meeting, as of the date above written, pursuant to Section 307(b) of the General Corporation Law of the State of California and the Corporation's Bylaws:

**Approval of Loan Transaction**

WHEREAS, Corey Kirschner is currently the Corporation's Chief Executive Officer, and Chief Financial Officer (the "Officer") with authority to enter into contracts on behalf of the Corporation.

WHEREAS, the Corporation opportunities from time to time to bid on various governmental and non-governmental projects;

WHEREAS, after careful consideration, the Board has determined that the terms and conditions of the proposed project in the form of the bid attached hereto as Exhibit A (the "Project") are just and equitable and fair as to the Corporation and that it is in the best interests of the Corporation and its stockholder to submit the bid and complete the Project subject to the terms agreed upon by the parties.

NOW, THEREFORE, BE IT RESOLVED, the Board on behalf of the Corporation hereby approves and ratifies the Project in all respects, and hereby authorize and direct the Corporation to negotiate, execute, deliver and perform the terms of all documents, required in connection with the Project, together with such changes thereto as may be approved by the Officer executing the same on behalf of the Corporation (pursuant to the authorization provided herein), such approval of the Officer to be conclusively evidenced by its execution and delivery of same.

RESOLVED FURTHER, that the Officer may execute and deliver any and all agreements and any and all other documents and instruments, and take such further actions as may be necessary or appropriate, for the financing of the Corporation.

RESOLVED FURTHER, that the Officer is hereby authorized, directed, and empowered to execute and deliver any and all agreements and any and all other documents and instruments, and take such further actions as may be necessary or appropriate, for the consummation of the Project.

**RESOLVED FURTHER**, that the Officer, in the name of the Corporation, is hereby authorized, directed, and empowered to negotiate, execute and deliver to the applicable counterparty, any and all documents with respect to the Project and other instruments as may be reasonably requested, and the Officer on behalf of the Corporation is authorized from time to time to execute renewals or extensions or other instruments as may be necessary.

**RESOLVED FURTHER**, that the authority given hereunder shall be deemed retroactive and any and all acts authorized hereunder performed prior to the passage of this resolution are hereby ratified and affirmed.

The Secretary of the Corporation is directed to file the original executed copy of this Consent with the minutes of proceedings of the Corporation.

[Signature page follows]





**ONYX PAVING COMPANY, INC.**  
License # 630360 - DIR. # 1000004798

**IN WITNESS WHEREOF, the undersigned has executed this Unanimous Written  
Consent of the Board of Directors as of the date first above written.**

  
\_\_\_\_\_

Corey Kirschner

# Request for Taxpayer Identification Number and Certification

Give Form to the requester. Do not send to the IRS.

Go to [www.irs.gov/FormW9](http://www.irs.gov/FormW9) for instructions and the latest information.

1 Name (as shown on your income tax return). Name is required on this line; do not leave this line blank.  
**ONYXPAVING COMPANY INC**

2 Business name/disregarded entity name, if different from above

3 Check appropriate box for federal tax classification of the person whose name is entered on line 1. Check only one of the following seven boxes.

Individual sole proprietor or single-member LLC  
 C Corporation  
 S Corporation  
 Partnership  
 Trust/estate  
 Limited liability company. Enter the tax classification (C=C corporation, S=S corporation, P=Partnership) \_\_\_\_\_  
Notes: Check the appropriate box in the line above for the tax classification of the single-member owner. Do not check LO if the LLC is classified as a single-member LLC that is disregarded from the owner unless the owner of the LLC is another LLC that is not disregarded from the owner for U.S. federal tax purposes. Otherwise, a single-member LLC that is disregarded from the owner should check the appropriate box for the tax classification of its owner.  
 Other (see instructions) \_\_\_\_\_

4 Exemptions (codes apply only to certain entities, not individuals; see instructions on page 3):  
Disrupt payee code (if any) \_\_\_\_\_  
Exemption from FATCA reporting code (if any) \_\_\_\_\_  
Payee is account established outside the U.S.

5 Address (number, street, and apt. or suite no.) See instructions.  
**2800 EAST LACRESTA AVE**

6 City, state, and ZIP code  
**ANAHEIM, CA 92806**

7 List account number(s) here (optional)

8 Requester's name and address (optional)

**Part III Taxpayer Identification Number (TIN)**

Enter your TIN in the appropriate box. The TIN provided must match the name given on line 1 to avoid backup withholding. For individuals, this is generally your social security number (SSN). However, for a resident alien, sole proprietor, or disregarded entity, see the instructions for Part I, later. For other entities, it is your employer identification number (EIN). If you do not have a number, see *How to get a TIN*, later.

Note: If the account is in more than one name, see the instructions for line 1. Also see *What Name and Number To Give the Requester* for guidelines on whose number to enter.

Social security number  
[ ][ ] - [ ][ ] - [ ][ ][ ][ ]

OR  
Employer identification number  
[ ][ ] - [ ][ ][ ][ ] - [ ][ ][ ][ ]

**Part IV Certification**

Under penalties of perjury, I certify that:

- The number shown on this form is my correct taxpayer identification number (or I am waiting for a number to be issued to me); and
- I am not subject to backup withholding because: (a) I am exempt from backup withholding, or (b) I have not been notified by the Internal Revenue Service (IRS) that I am subject to backup withholding as a result of a failure to report all interest or dividends, or (c) the IRS has notified me that I am no longer subject to backup withholding; and
- I am a U.S. citizen or other U.S. person (defined below); and
- The FATCA code(s) entered on this form (if any) indicating that I am exempt from FATCA reporting is correct.

**Certification instructions.** You must cross out item 2 above if you have been notified by the IRS that you are currently subject to backup withholding because you have failed to report all interest and dividends on your tax return. For real estate transactions, item 2 does not apply. For mortgage interest paid, acquisition or abandonment of secured property, cancellation of debt, contributions to an individual retirement arrangement (IRA), and generally, payments other than interest and dividends, you are not required to sign the certification, but you must provide your correct TIN. See the instructions for Part IV, later.

Sign Here Signature of U.S. person **ANA RAYSON** Date **3/22/2021**

**General Instructions**

Section references are to the Internal Revenue Code unless otherwise noted.

**Future developments.** For the latest information about developments related to Form W-9 and its instructions, such as legislation enacted after they were published, go to [www.irs.gov/FormW9](http://www.irs.gov/FormW9).

**Purpose of Form**

An individual or entity (Form W-9 requester) who is required to file an information return with the IRS must obtain your correct taxpayer identification number (TIN) which may be your social security number (SSN), individual taxpayer identification number (ITIN), adoption taxpayer identification number (ATIN), or employer identification number (EIN), to report on an information return the amount paid to you, or other amount reportable on an information return. Examples of information returns include, but are not limited to, the following:

- Form 1099-INT (interest earned or paid)
- Form 1099-DIV (dividends, including those from stocks or mutual funds)
- Form 1099-MISC (various types of income, prizes, awards, or gross proceeds)
- Form 1099-B (stock or mutual fund sales and certain other transactions by brokers)
- Form 1099-S (proceeds from real estate transactions)
- Form 1099-K (merchant card and third party network transactions)
- Form 1098 (home mortgage interest), 1098-E (student loan interest), 1098-T (tuition)
- Form 1099-C (canceled debt)
- Form 1099-A (acquisition or abandonment of secured property)

Use Form W-9 only if you are a U.S. person (including a resident alien), to provide your correct TIN.

If you do not return Form W-9 to the requester with a TIN, you might be subject to backup withholding. See *What is backup withholding*, later.



# CERTIFICATE OF LIABILITY INSURANCE

DATE (MM/DD/YYYY)  
3/12/2021

THIS CERTIFICATE IS ISSUED AS A MATTER OF INFORMATION ONLY AND CONFERS NO RIGHTS UPON THE CERTIFICATE HOLDER. THIS CERTIFICATE DOES NOT AFFIRMATIVELY OR NEGATIVELY AMEND, EXTEND OR ALTER THE COVERAGE AFFORDED BY THE POLICIES BELOW. THIS CERTIFICATE OF INSURANCE DOES NOT CONSTITUTE A CONTRACT BETWEEN THE ISSUING INSURER(S), AUTHORIZED REPRESENTATIVE OR PRODUCER, AND THE CERTIFICATE HOLDER.

IMPORTANT: If the certificate holder is an ADDITIONAL INSURED, the policy(ies) must be endorsed. If SUBROGATION IS WAIVED, subject to the terms and conditions of the policy, certain policies may require an endorsement. A statement on this certificate does not confer rights to the certificate holder in lieu of such endorsement(s).

PRODUCER  
Wood Gutmann & Bogert  
15901 Red Hill Ave., Suite 100  
Tustin CA 92780

CONTACT: Michael Tran  
TEL No: 714-824-8384 FAX No: 714-873-1770  
ADDRESS: mtran@wgbib.com

INSURED  
Onyx Paving Company, Inc.  
2880 E. La Cuesta Avenue  
Anaheim CA 92808-1818

License# 0679286  
ONYX-P-1

INSURER	NAIC#
INSURER A: West American Ins Co	44393
INSURER B: Zurich American Insurance Co.	18836
INSURER C: AMERICAN ZURICH INS CO	40142
INSURER D:	
INSURER E:	
INSURER F:	

COVERAGES CERTIFICATE NUMBER: 1512732609 REVISION NUMBER:

THIS IS TO CERTIFY THAT THE POLICIES OF INSURANCE LISTED BELOW HAVE BEEN ISSUED TO THIS INSURED NAMED ABOVE FOR THE POLICY PERIOD INDICATED. NOTWITHSTANDING ANY REQUIREMENT, TERM OR CONDITION OF ANY CONTRACT OR OTHER DOCUMENT WITH RESPECT TO WHICH THIS CERTIFICATE MAY BE ISSUED OR MAY PERTAIN, THE INSURANCE AFFORDED BY THE POLICIES DESCRIBED HEREIN IS SUBJECT TO ALL THE TERMS, EXCLUSIONS AND CONDITIONS OF SUCH POLICIES. LIMITS SHOWN MAY HAVE BEEN REDUCED BY PAID CLAIMS.

TYPE OF INSURANCE	APPLICABLE TO (Y/N)	POLICY NUMBER	START DATE (MM/DD/YYYY)	EXPIRES (MM/DD/YYYY)	LIMITS
<input checked="" type="checkbox"/> COMMERCIAL GENERAL LIABILITY <input type="checkbox"/> CLAIMS-MADE <input checked="" type="checkbox"/> OCCUR  GEN'L AGGREGATE LIMIT APPLIES PER: <input type="checkbox"/> POLICY <input checked="" type="checkbox"/> PRO-JECT <input type="checkbox"/> LOC <input type="checkbox"/> OTHER		ERN506227044	3/14/2021	3/14/2022	EACH OCCURRENCE \$2,000,000 DAMAGE TO RENTED PREMISES (Per occurrence) \$100,000 AUTO EXP (Any one person) \$10,000 PERSONAL & ADY INJURY \$2,000,000 GENERAL AGGREGATE \$4,000,000 PRODUCTS - COMP/CP AGG \$4,000,000
<input checked="" type="checkbox"/> AUTOMOBILE LIABILITY <input checked="" type="checkbox"/> ANY AUTO <input type="checkbox"/> ALL OWNED AUTOS <input type="checkbox"/> SCHEDULED AUTOS <input type="checkbox"/> NON-OWNED AUTOS <input type="checkbox"/> HIRED AUTOS		BAP106100E02	10/1/2020	10/1/2021	OWNED AND NON-OWNED LIMIT (Per person) \$2,000,000 BODILY INJURY (Per person) \$ BODILY INJURY (Per accident) \$ PROPERTY DAMAGE (Per occurrence) \$ (Per occurrence) \$
<input type="checkbox"/> UMBRELLA LIAB <input type="checkbox"/> EXCESS LIAB <input type="checkbox"/> OCCUR <input type="checkbox"/> CLAIMS-MADE <input type="checkbox"/> RETENTION \$					EACH OCCURRENCE \$ AGGREGATE \$ \$
<input checked="" type="checkbox"/> WORKERS COMPENSATION AND EMPLOYERS' LIABILITY ANY PROPRIETOR/PARTNER/EXECUTIVE OFFICER/OWNER EXCLUDED? (Mandatory Initial) If yes, state the order DESCRIPTION OF OPERATIONS below	Y/N N/A	WC106300D32	10/1/2020	12/31/2021	<input checked="" type="checkbox"/> PER STARVE <input type="checkbox"/> OFF-ICE EL EACH ACCIDENT \$1,000,000 EL DISEASE - EA EMPLOYEE \$1,000,000 EL DISEASE - POLICY LIMIT \$1,000,000

DESCRIPTION OF OPERATIONS / LOCATIONS / VEHICLES (ACORD 101, Additional Remarks Schedule, may be attached if more space is required)  
Certificate holder(s) is/are named as additional insured per the attached endorsements as required by written contract subject to the terms & conditions of the policy.

- GL Additional Insured Form #CG 20 10 04 13 and CG 20 87 04 13
  - GL Additional Insured State-Permits Form #CG 20 13 04 13
  - GL Primary and Non-Contributory Form #CG 20 01 04 13
  - GL Waiver of Subrogation Form #CG 88 10 04 13
  - GL Per Project Form #CG 88 70 12 08
- See Attached...

### CERTIFICATE HOLDER

Onyx Paving Company, Inc.  
2880 E. La Cuesta Ave.  
Anaheim CA 92808

### CANCELLATION

SHOULD ANY OF THE ABOVE DESCRIBED POLICIES BE CANCELLED BEFORE THE EXPIRATION DATE THEREOF, NOTICE WILL BE DELIVERED IN ACCORDANCE WITH THE POLICY PROVISIONS.

AUTHORIZED REPRESENTATIVE

© 1988-2014 ACORD CORPORATION. All rights reserved.



**State of California  
Secretary of State**

8

**Statement of Information  
(Domestic Stock and Agricultural Cooperative Corporations)**

**FEES (Filing and Disclosure): \$25.00.**

If this is an amendment, see instructions.

**IMPORTANT -- READ INSTRUCTIONS BEFORE COMPLETING THIS FORM**

G076477

**FILED**

In the office of the Secretary of State  
of the State of California

OCT-01 2018

**1. CORPORATE NAME**

ONYX PAVING COMPANY, INC.

**2. CALIFORNIA CORPORATE NUMBER**

C1659076

Title Space for Filing Use Only

**No Change Statement (Not applicable if agent address of record is a P.O. Box address. See instructions.)**

2. If there have been any changes to the information contained in the last Statement of Information filed with the California Secretary of State, or no statement of information has been previously filed, this form must be completed in its entirety.  
 If there has been no change in any of the information contained in the last Statement of Information filed with the California Secretary of State, check the box and proceed to Item 17.

**Complete Addresses for the Following (Do not abbreviate the name of the city. Items 4 and 6 cannot be P.O. Boxes.)**

	CITY	STATE	ZIP CODE
4. STREET ADDRESS OF PRINCIPAL EXECUTIVE OFFICE 2890 E. LA CRESTA AVE., ANAHEIM, CA 92808			
5. STREET ADDRESS OF PRINCIPAL BUSINESS OFFICE IN CALIFORNIA, IF ANY 2890 E. LA CRESTA AVE., ANAHEIM, CA 92808			
6. MAILING ADDRESS OF CORPORATION, IF DIFFERENT THAN ITEM 4			

**Names and Complete Addresses of the Following Officers (The corporation must list these three officers. A comparable title for the specific officer may be added; however, the preprinted titles on this form must not be altered.)**

	ADDRESS	CITY	STATE	ZIP CODE
7. CHIEF EXECUTIVE OFFICER/ COREY KIRSCHNER	2890 E. LA CRESTA AVE., ANAHEIM, CA 92808			
8. SECRETARY COREY KIRSCHNER	2890 E. LA CRESTA AVE., ANAHEIM, CA 92808			
9. CHIEF FINANCIAL OFFICER/ COREY KIRSCHNER	2890 E. LA CRESTA AVE., ANAHEIM, CA 92808			

**Names and Complete Addresses of All Directors, Including Directors Who are Also Officers (The corporation must have at least one director. Attach additional pages, if necessary.)**

	ADDRESS	CITY	STATE	ZIP CODE
10. NAME COREY KIRSCHNER	2890 E. LA CRESTA AVE., ANAHEIM, CA 92808			
11. NAME	ADDRESS	CITY	STATE	ZIP CODE
12. NAME	ADDRESS	CITY	STATE	ZIP CODE

**13. NUMBER OF VACANCIES ON THE BOARD OF DIRECTORS, IF ANY:**

**Agent for Service of Process** If the agent is an individual, the agent must reside in California and Item 15 must be completed with a California street address, a P.O. Box address is not acceptable. If the agent is another corporation, the agent must have on file with the California Secretary of State a certificate pursuant to California Corporations Code section 1805 and Item 15 must be left blank.

**14. NAME OF AGENT FOR SERVICE OF PROCESS**

COREY KIRSCHNER

	CITY	STATE	ZIP CODE
15. STREET ADDRESS OF AGENT FOR SERVICE OF PROCESS IN CALIFORNIA, IF AN INDIVIDUAL 2890 E. LA CRESTA AVE., ANAHEIM, CA 92808			

**Type of Business**

16. DESCRIBE THE TYPE OF BUSINESS OF THE CORPORATION  
ASPHALT PAVING SERVICES

17. BY SUBMITTING THIS STATEMENT OF INFORMATION TO THE CALIFORNIA SECRETARY OF STATE, THE CORPORATION CERTIFIES THE INFORMATION CONTAINED HEREIN, INCLUDING ANY ATTACHMENTS, IS TRUE AND CORRECT.

10/01/2018 AFSHIN HAKIM ATTORNEY  
DATE TYPEPRINT NAME OF PERSON COMPLETING FORM TITLE SIGNATURE



**State of California**  
**Secretary of State**

**9**

**Statement of Information**

(Domestic Stock and Agricultural Cooperative Corporations)

**FEE\$ (Filing and Disclosure): \$25.00.**

If this is an amendment, see Instructions.

**IMPORTANT - READ INSTRUCTIONS BEFORE COMPLETING THIS FORM**

**GB88157**

**FILED**

In the office of the Secretary of State  
of the State of California

**JAN-03 2020**

1. CORPORATE NAME  
ONYX PAVING COMPANY, INC.

2. CALIFORNIA CORPORATE NUMBER  
C1659076

This Space for Filing Use Only

No Change Statement (Not applicable if agent address of record is a P.O. Box address. See Instructions.)  
3. If there have been any changes to the information contained in the last Statement of Information filed with the California Secretary of State, or no statement of information has been previously filed, this form must be completed in its entirety.  
 If there has been no change in any of the information contained in the last Statement of Information filed with the California Secretary of State, check the box and proceed to Item 17.

Complete Addresses for the Following (Do not abbreviate the name of the city. Items 4 and 5 cannot be P.O. Boxes.)

4. STREET ADDRESS OF PRINCIPAL EXECUTIVE OFFICE	CITY	STATE	ZIP CODE
5. STREET ADDRESS OF PRINCIPAL BUSINESS OFFICE IN CALIFORNIA, IF ANY	CITY	STATE	ZIP CODE
6. MAILING ADDRESS OF CORPORATION, IF DIFFERENT THAN ITEM 4	CITY	STATE	ZIP CODE

Names and Complete Addresses of the Following Officers (The corporation must list these three officers. A comparable title for the specific officer may be added; however, the preprinted titles on this form must not be altered.)

7. CHIEF EXECUTIVE OFFICER	ADDRESS	CITY	STATE	ZIP CODE
8. SECRETARY	ADDRESS	CITY	STATE	ZIP CODE
9. CHIEF FINANCIAL OFFICER	ADDRESS	CITY	STATE	ZIP CODE

Names and Complete Addresses of All Directors, Including Directors Who are Also Officers (The corporation must have at least one director. Attach additional pages, if necessary.)

10. NAME	ADDRESS	CITY	STATE	ZIP CODE
11. NAME	ADDRESS	CITY	STATE	ZIP CODE
12. NAME	ADDRESS	CITY	STATE	ZIP CODE

13. NUMBER OF VACANCIES ON THE BOARD OF DIRECTORS, IF ANY:  
Agent for Service of Process If the agent is an individual, the agent must reside in California and item 15 must be completed with a California street address, a P.O. Box address is not acceptable. If the agent is another corporation, the agent must have on file with the California Secretary of State a certificate pursuant to California Corporations Code section 1606 and item 15 must be left blank.

14. NAME OF AGENT FOR SERVICE OF PROCESS

15. STREET ADDRESS OF AGENT FOR SERVICE OF PROCESS IN CALIFORNIA, IF AN INDIVIDUAL CITY STATE ZIP CODE

Type of Business  
16. DESCRIBE THE TYPE OF BUSINESS OF THE CORPORATION

17. BY SUBMITTING THIS STATEMENT OF INFORMATION TO THE CALIFORNIA SECRETARY OF STATE, THE CORPORATION CERTIFIES THE INFORMATION CONTAINED HEREIN, INCLUDING ANY ATTACHMENTS, IS TRUE AND CORRECT.

01/03/2020 ANA BARBRA RAYPON OFFICE MANAGER/CONTROLLER

DATE TYPE/PRINT NAME OF PERSON COMPLETING FORM TITLE SIGNATURE



# APPLICATION FOR PUBLIC WORKS CONTRACTOR REGISTRATION

## Registration Information

---

Type: Public Works  
Period: 07/01/2023 06/30/2024

## Contractor Information

---

Contractor Name: ONYX PAVING COMPANY, INC.  
Trade Name:  
License Type Number: 1000004798

## Contractor Physical Address

---

Physical Business Country: United States of America	Physical Business City/ ANAHEIM Province:
Physical Business Address: 2890 E. LA CRESTA AVENUE	Physical Business State: CA
	Physical Business Postal 92806 Code:

## Contractor Mailing Address

---

Mailing Country: United States of America	Mailing City /Province: ANAHEIM
Mailing Address: 2890 E. LA CRESTA AVENUE	Mailing State: CA
	Mailing Postal Code: 92806

## Contact Info

---

Daytime Phone:	Daytime Phone Ext.:
Mobile Phone:	Business Email: davidw@onyxpaving.com
	Applicant's Email: davidw@onyxpaving.net

# Workers' Compensation

---

## Professional Employer Organization (PEO)

---

Do you lease employees through Professional Employer Organization? No

## Workers' Compensation Overview

---

Carrier: ZURICH AMERICAN INSURANCE  
COMPANY

Inception Date: 10/01/2022

Policyholder Name: Onyx Paving Company Inc

Expiration Date: October 12, 2023

Policy Number: WC106300504

## Certification

---

Yes I certify that I do not have any delinquent liability to an employee or the state for any assessment of back wages or related damages, interest, fines, or penalties pursuant to any final judgment, order, or determination by a court or any federal, state, or local administrative agency, including a confirmed arbitration award

Yes I certify that the contractor is not currently debarred under Section 1777.1 or under any other federal or state law providing for the debarment of contractors from public works.

Yes I certify that one of the following is true: (1) I am licensed by the Contractors State License Board (CSLB) in accordance with Chapter 9 (commencing with Section 7000) of the Business and Professions Code; or (2) my business or trade is not subject to licensing by the CSLB.

I understand refunds are not authorized

I, David Wiltfong, the undersigned, am , ONYX PAVING COMPANY, INC. with the authority to act for and on behalf of the above named contractor. I certify under penalty of perjury that all of the above information provided is true and correct. I further acknowledge that any untruthful information provided in this application could result in the certification being canceled.

I certify this on: 10:00 AM

## Legal Entity Information

---

### Legal Entity Type: Corporation

Name: ONYX PAVING COMPANY, INC.



Mark Lancaster, P.E.  
Director of Transportation

# COUNTY OF RIVERSIDE

## TRANSPORTATION AND LAND MANAGEMENT AGENCY

Mojahed Salama, P.E.  
Deputy for Transportation  
Capital Projects

Russell Williams  
Deputy for Transportation  
Planning and Development

### Transportation Department

#### ADDENDUM NUMBER 1

Dated June 28, 2023

to the  
Specifications and Contract Documents  
for the construction of

Johnston Avenue Resurfacing  
San Jacinto Street to 630-Foot East of Stanford Street  
Community of East Hemet  
Project No. B0-0612

**Bids Due: Wednesday, July 5, 2023; 2:00 p.m.**  
14<sup>th</sup> Street Transportation Annex  
3525 14<sup>th</sup> Street; Riverside, CA 92501  
(951) 955-6780

This Addendum is issued pursuant to the Instructions to Bidders, Item No. 8, of the Contract Documents for the reference project. This Addendum is issued as a supplement to the specification and special provisions for the referenced project. The revisions to the specifications shall become a part of the Contract Documents, and each bidder shall acknowledge receipt thereof on the Bid (Proposal). Bidders are directed to sign this addendum as acknowledged and attach the signed addendum to the contractor's submitted proposal.

Note: During the advertisement period of this project, this document and attachments (if any) are available upon request at the office of the Transportation Department, and are available as a free download at the Transportation Department's website:

<https://trans.rctlma.org/notices-inviting-bids>

#### MODIFICATIONS / CLARIFICATIONS TO SPECIAL PROVISIONS:

**Item 1: Revised Proposal**

Refer to "Proposal" pages B2-B4. Delete and replace "Proposal" (pages B2-B4) with "Proposal (Revised)" attached herewith as **Attachment "A"**.

**Note: Revisions made to the proposal by Addendum No. 1 are written with blue font/numbers in Attachment "A".**

- a. Item description and quantity has been revised for the following item:  
Item 16, ADJUST UTILITY COVER TO GRADE [WATER METER, LHMWD]



**Item 2: Adjust Existing Water Meter Boxes To Grade.**

Refer to Section 71-8, "Adjust Existing Water Meter Boxes To Grade (Including Installing Traffic Rated Cover)," on pages 50 and 51 of the special provisions. Delete Section 71-8 and replace it with the following:

**71-8 ADJUST EXISTING WATER METER BOXES TO GRADE**

**71-8.01 GENERAL**

**71-8.01A General**

**71-8.01(1) Summary**

Section 71-8 includes specifications for adjusting existing Lake Hemet Municipal Water District (LHMWD) water meter boxes to grade.

Contractor shall comply with the applicable LHMWD special provisions and standard plans.

**71-8.02 Materials**

Existing water meter boxes shall be adjusted to finished grade with materials similar in quality to those in the original structure in accordance with these Special Provisions.

Water meter boxes must comply with all requirements of LHMWD standard specifications and plans and as directed by Engineer.

Contractor must provide coordination with LHMWD for all work associated with their facilities.

**71-8.03 Construction**

All work shall be performed by a Licensed and qualified plumber.

The Contractor shall furnish and install all required materials and equipment needed to complete the work specified herein.

The contractor will make all connections to existing water line.

Attention is directed to Section 00-1.10, Cooperation, of these Special Provisions for fully cooperation with LHMWD. The contractor must cooperate with LHMWD in performing the work required to make the connection to the existing water line including but not limited to providing materials, excavation, traffic control, and backfill, in conformance with the Standard Specifications, these Special Provisions and as directed by the Engineer.

**71-8.04 Payment**

The contract unit bid price paid per each for Adjust Utility Cover To Grade [Water Meter, LHMWD] shall include full compensation for furnishing all labor, materials, tools, equipment, and incidentals, for doing all the work involved and no additional compensation will be allowed therefor.

**MODIFICATIONS / CLARIFICATIONS TO THE PLANS:**

**Item 3: Plan sheet revisions.**

Refer to plans for Johnston Avenue Resurfacing, San Jacinto Street to 630-Foot East of Stanford Street, Community of East Hemet, Project No. B0-0612. The following plans modifications are reflected on the revised construction plans attached herewith as **Attachment "B"**.

- **Construction Note 16.** Refer to plans sheets 3, 4, 6 and 7 of 17. Original construction note 16, "ADJUST WATER METER TO GRADE AND INSTALL TRAFFIC RATED COVER PER LHMWD STANDARDS" is deleted and replaced with:

**16 ADJUST WATER METER TOR GRADE PER LHMWD STANDARDS**

- **Replace callout note 16 at various locations.** Refer to plans sheets 4, 5 and 7 of 17. Original callout notes No. 16 found at the following approximate locations on Johnston Avenue are replaced with callout notes No. 1 for "PROTECT"

**On Sheet 4 of 17, L-1**

<u>At approximately station</u>	<u>Side</u>
27+90	North
37+40	South

**On Sheet 5 of 17, L-2**

<u>At approximately station</u>	<u>Side</u>	<u>At approximately station</u>	<u>Side</u>
38+05	South	44+05	North
38+35	North	44+45	North
39+40	North	44+65	South
40+05	North	45+10	North
40+30	South	45+75	North
40+70	North	46+50	North
41+15	South	46+70	South
41+20	North	47+45	North
41+90	North	47+80	South
42+60	North	48+30	North
43+40	North	50+55	South
43+95	South	51+30	South

**On Sheet 7 of 17, L-4**

<u>At approximately station</u>	<u>Side</u>	<u>At approximately station</u>	<u>Side</u>
78+50	South	81+50	North
79+00	North	81+60	South
79+30	South	82+30	South
79+60	North	82+55	North
79+90	South	82+65	North
80+65	South	84+75	North

• **Delete and replace** the following five (5) plans sheets from the set:

1. Plan sheet 3 of 17, X-1
2. Plan sheet 4 of 17, L-1
3. Plan sheet 5 of 17, L-2
4. Plan sheet 6 of 17, L-3
5. Plan sheet 7 of 17, L-4

Note: Revised plan sheet(s) is (are) posted on the County website and available for download during the advertisement period.

<https://trans.rctlma.org/notices-inviting-bids>

**ATTACHMENTS**

**A – Revised Proposal (3 sheets)**

**B – Revised Plan Sheets (5 sheets)**

This addendum has been prepared under the direction of the following registered Civil Engineer(s):

**Recommended by:**

*Mike Heath*

Mike Heath, PE  
Sr. Civil Engineer



**Concurrence:**

*Khalid Nasim*

Khalid Nasim, PE  
Engineering Division Manager

**Acknowledged:**

A blue ink signature of Corey R. Kirschner.

COREY R. KIRSCHNER -  
CEO, PRES, VP, SEC, TREA. Date: 06/29/2023

(Contractor)

JRJ:jrj:jr

Note: Refer to Instruction to Bidders Item No. 8, "Addenda". Submission of all addendum pages and non-bidding document attachments of addendum are not necessary for Bid submittal. Submittal of this acknowledgement page is adequate for Bid reception. Bidders are reminded to list addendum number(s) received on the first page of the Bid form (Proposal).

**SPECIFICATIONS and CONTRACT DOCUMENTS**  
**for the**  
**CONSTRUCTION**  
**of**

Johnston Avenue Resurfacing  
San Jacinto Street to 630-Foot East of Stanford Street  
Community of East Hemet  
Project No. B0-0612



**TRANSPORTATION DEPARTMENT**

## General

### Table of Contents

<u>Description</u>	<u>Page</u>
Vicinity Map	i
Specifications and Contract Documents Approvals	ii – iv
Notice To Bidders	v
Instruction to Bidders*	A1 – A13
Bidding Documents	
Bid	B1
Bid Items	B2 – B4
Bidder Data and Signature	B5 – B6
Subcontractor List	B7
Non-Collusion Declaration	B8
Iran Contacting Act, Certification or Exemption	B9
Opt Out of Payment Adjustments for Price Index Fluctuations	B10
Bid Bond	B11
Contract and other Bonds	
Contract	C1 – C4
Performance Bond	C5
Payment Bond	C6

\* **Note:** See the first page of this document description for a detailed Table of Contents.

## General

### Table of Contents (continued)

General Conditions*	GC1 – GC33
Special Provisions*	1 – 58
Appendices	
AQMD Recommendations*	Appendix A
Reference Drawings	Appendix B
Attachment “C” for Risk Level 1 Requirements	Appendix C
County of Riverside Transportation Department Contractor Job Mix Formula Proposal	Appendix D

\* **Note:** See the first page of this document description for a detailed Table of Contents.

COUNTY OF RIVERSIDE  
**TRANSPORTATION DEPARTMENT**

**JOHNSTON AVENUE RESURFACING**

SAN JACINTO STREET TO 630-FEET EAST OF STANFORD STREET

COMMUNITY OF EAST HEMET

PROJECT No. B0-0612

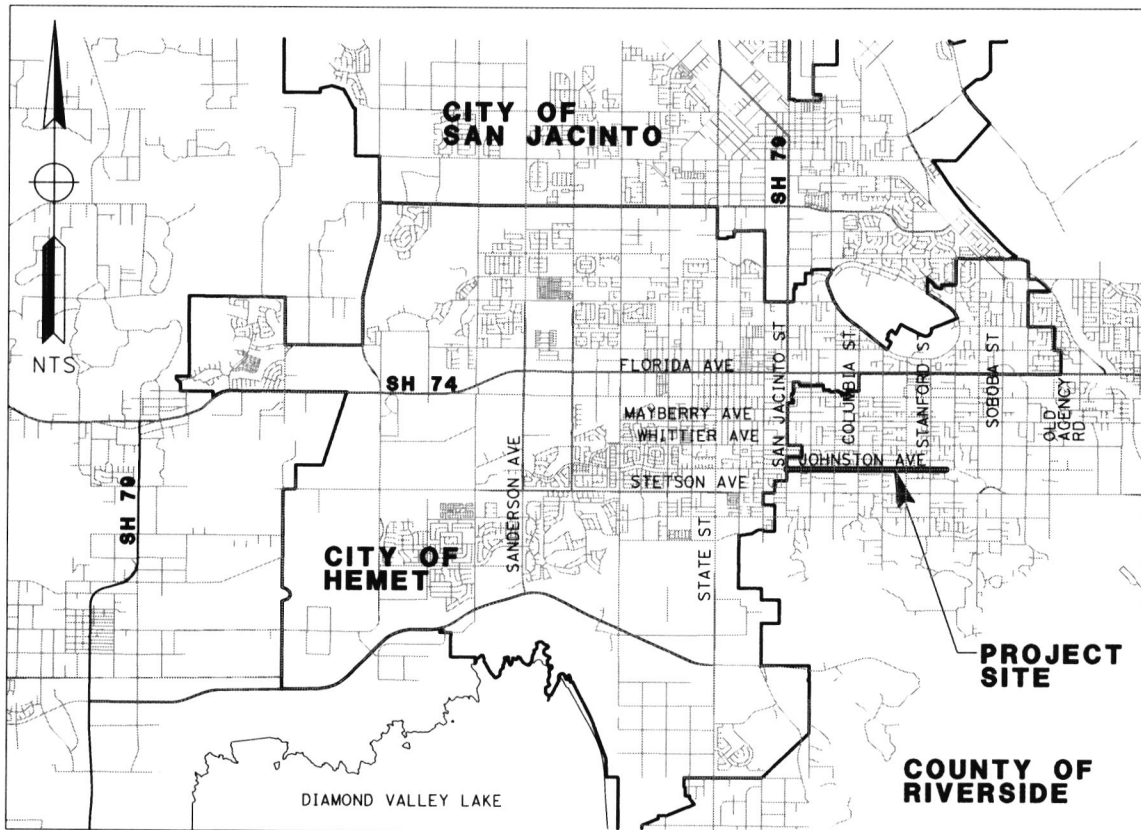
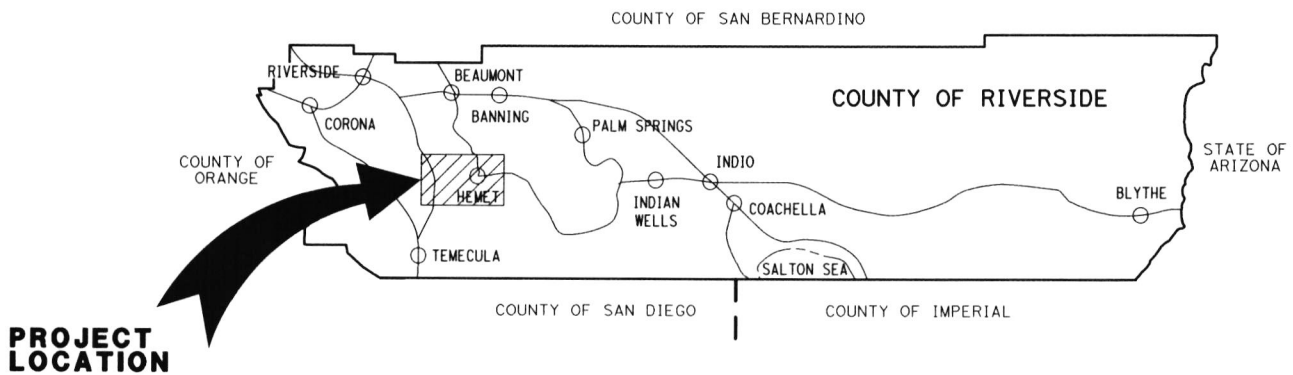

**VICINITY MAP**



**Specifications and Contract Documents**  
for the construction of

**Johnston Avenue Resurfacing**  
**San Jacinto Street to 630-Foot East of Stanford Street**  
**Community of East Hemet**  
**Project No. B0-0612**

**Contract Approval(s)**

**Approval:**

*Khalid Nasim*

5/11/2023

Khalid Nasim, PE  
Engineering Division Manager

Date

**Engineering Certification(s)**

These specifications, special provisions, and estimates have been prepared by or under the direction of the following Registered Civil Engineer(s):

*Mike Heath*

Mike Heath, PE

05/09/2023

Date



**Specifications and Contract Documents**  
for the construction of

**Johnston Avenue Resurfacing**  
**San Jacinto Street to 630-Feet East of Stanford Street**  
**Community of East Hemet**  
**Project No. B0-0612**

**Water Pollution Control – Specifications and Special Provisions**

**Reviewed and Recommended by:**

  
\_\_\_\_\_

Jan Bulinski  
Environmental Project Manager/NPDES  
Coordinator

5/10/23  
\_\_\_\_\_

Date

**Specifications and Contract Documents**  
for the construction of

**Johnston Avenue Resurfacing  
San Jacinto Street to 630-Feet East of Stanford Street  
Community of East Hemet  
Project No. B0-0612**

**Transportation Department Management Review and Recommendation**

<p><b>Traffic Engineering</b></p> <p> _____ Dennis Acuna Engineering Division Manager</p> <p align="right">5/11/2023 _____ Date</p>	<p><b>Highway Operations</b></p> <p> _____ Paul Russell Highway Operations Superintendent</p> <p align="right">5/10/23 _____ Date</p>
<p><b>Environmental</b></p> <p> _____ Jan Bulinski Environmental Project Manager</p> <p align="right">5/10/23 _____ Date</p>	<p><b>Construction / Inspection</b></p> <p> _____ Cindi Wachi Engineering Division Manager</p> <p align="right">05/11/2023 _____ Date</p>
<p><b>Project Development</b></p> <p> _____ Khalid Nasim Engineering Division Manager</p> <p align="right">5/11/2023 _____ Date</p>	<p><b>Engineering/ Planning</b></p> <p> _____ Mojahed Salama Deputy Director</p> <p align="right">5/11/2023 _____ Date</p>

## Notice to Bidders

County of Riverside, herein called Owner, invites sealed proposals for:

**Johnston Avenue Resurfacing  
San Jacinto Street to 630-Foot East of Stanford Street  
Community of East Hemet  
Project No. B0-0612**

Bid shall be delivered to the County of Riverside Transportation Department, 14<sup>th</sup> Street Annex, 3525 14<sup>th</sup> Street, Riverside, California 92501, telephone (951) 955-6780 not later than 2:00 p.m., on Wednesday, **July 5, 2023**, to be promptly opened in public at said address. Each bid shall be in accordance with plans, specifications and other contract documents, dated **May 2023**, and prepared by County of Riverside, whose address is same as the above, from whom a digital set of documents (bid book and plans) may be obtained upon request, at no cost, or a printed set of bidding documents with 22" x 34" size plans may be obtained upon request for a nonrefundable fee of **\$40.00** per set, plus mailing costs. Email request of bidding documents, with company and contact information, to **Bids-Contracts@rivco.org** and reference this project (or contact the address or telephone number above).

Pursuant to Labor Code section 1771.1, any Contractor bidding, or subcontractor to be listed on a bid proposal subject to Public Contract Code section 4104, shall not be qualified to bid after March 1, 2015, unless currently registered and qualified to perform public works pursuant to Labor Code section 1725.5. No Contractor or subcontractor may be awarded a contract or perform work on any contract for public work, after April 1, 2015, without proof of current registration with the Department of Industrial Relations pursuant to Labor Code section 1725.5 to perform public works.

The County of Riverside, in accordance with Title VI of the Civil Rights Act of 1964 (78 Stat. 252) and the Regulations of the Department of Commerce (15 C.F.R., Part 8) and related statutes, issued pursuant to such Act, hereby notifies all bidders that minority businesses will be afforded full opportunity to submit bids, and it will affirmatively insure that the contract entered into pursuant to this advertisement will be awarded to the lowest responsible bidder without discrimination on the grounds of race, color, sex, national origin, religion, age, or disability.

The Contractor is required to have a Class "A" license at the time of bid submission.

Engineering Estimate:	\$ 2,650,000 - \$ 3,100,000	(Base Bid Schedule)
	\$ 11,000 - \$ 13,000	(Alternative Bid Schedule 1)

Bid Bond	10 %
Performance Bond	100 %
Payment Bond	100 %
Working Days	60

Website: <http://rctlma.org/trans/Contractors-Corner/Notices-Inviting-Bids>

## Instructions to Bidders

### Table of Contents

1.	Inspection of Site .....	A 2
2.	Bidder's Bid Form .....	A 2
3.	Bid Bond .....	A 3
4.	Non-Collusion Declaration .....	A 3
5.	Additional Bidding Forms .....	A 3
	A. Iran Contracting Act, Certification or Exemption .....	A 3
	B. Opt Out of Payment Adjustments for Price Index Fluctuations .....	A 3
6.	Interpretation of Documents .....	A 4
7.	Quantities .....	A 4
8.	Addenda .....	A 5
9.	License .....	A 5
10.	Contract Participation .....	A 5
11.	Subletting, Subcontracting, and Subcontractor List .....	A 5
12.	Registration with the Department of Industrial Relations (DIR).....	A 7
13.	Hours of Work .....	A 7
14.	Alternate Bid Schedules.....	A 7
15.	Bids .....	A 8
16.	Like Bid Items.....	A 9
17.	Contract Documents.....	A 10
18.	Submission of Bidder's Bid .....	A 10
19.	Qualifications of Bidders .....	A 10
20.	Award of Contract.....	A 10
21.	Payment and Performance Bonds .....	A 12
22.	Return of Bid Guarantee .....	A 13
23.	Submission of Insurance Certificate and Endorsements.....	A 13

## **Instructions to Bidders**

The Bidder's attention is directed to the provisions in Standard Specifications Section 2, "Bidding" and the Contract Documents, including the Plans and the Special Provisions, for the requirements and conditions which the Bidder must observe in the preparation of and the submission of the Bid.

In compliance with the Americans with Disabilities Act, persons with disabilities may request for assistance and reasonable accommodations (including auxiliary aids and services at no cost) to participate in the pre-bid meeting (if scheduled and as designated in the Notice to Bidders) or bid opening meeting (as scheduled in the Notice to Bidders). The physical location of the pre-bid meeting and bid opening is accessible to persons with disabilities. If assistance is needed, please contact the Project Development Division at 951-955-6780 or [rrjimenez@rivco.org](mailto:rrjimenez@rivco.org) at least 3 business days before the scheduled event.

In compliance with Title II of the Americans with Disabilities Act (ADA), the County of Riverside does not discriminate on the basis of disability in admission to, access to, or operations of its programs, services or activities. It is committed to ensuring that its programs, services and activities are fully accessible to and usable by people with disabilities.

To accommodate persons with disabilities, documents in this Bid Book are available in alternate formats upon request.

### 1. Inspection of Site

Bidder's attention is directed to Standard Specifications Section 2-1.07, "Job Site and Document Examination." Bidders must examine the site and acquaint themselves with all conditions affecting the work. By making and submitting a bid, a Bidder warrants that he has made such site examination as the Bidder deems necessary for the condition of the site, its accessibility for materials, workmen and utilities, and for the ability to protect existing surface and subsurface improvements. No claim for allowances, time or money, will be allowed as to such matters.

### 2. Bidder's Bid Form

The Bid must be made on the Bid forms, which are included in the Contract Documents, and must be completely filled in, dated and signed. Signature(s) provided by the Bidder must be from an authorized officer or agent (see Bidder Data and Signature sheets).

If provision is made for alternate bid schedule(s), all bid schedules must be bid, unless otherwise instructed in the Special Provisions.

All Bid forms shall be obtained from the Riverside County Transportation Department, 3525 14<sup>th</sup> Street, Riverside, California 92501.

3. Bid Bond

All Bidders are required to use the bond form found in the Bid Book's "B" pages; the form is titled "Bid Bond."

The Bid must be accompanied by a 10% Bid Bond using the form provided in the Bid Book, or a certified check, or cashier's check payable to the order of "County of Riverside," in an amount not less than 10% of the bid amount, inclusive of alternate bid schedule(s). Submitted Bid Bond form must be completely filled in, sealed, dated and signed. Signatures on the Bid Bond must be notarized. Bond shall be provided with an executed Power of Attorney issued by the surety.

4. Non-Collusion Declaration

In conformance with Public Contract Code §7106, a Non-Collusion Declaration is included in the Bid. Bidder Declaration must be submitted using the form provided in the Bid Book and it must be completely filled in, dated and signed. Signatures on the Non-Collusion Declaration must be notarized.

5. Additional Bidding Forms

A. Iran Contracting Act, Certification or Exemption

The Department of General Services has published a list of companies who are prohibited from contracting with public entities in California as required by Public Contract Code §2200 through §2208.

The Iran Contracting Act Certification/Exemption form is included in the Bid Book. For projects estimated or Bid, in the amount of \$1,000,000 or more, Bidder must completely fill in, date, sign and submit this form with the Bid documents.

B. Opt Out of Payment Adjustments for Price Index Fluctuations

Bidder's attention is directed to Standard Specifications Section 2-1.31, "Opt Out of Payment Adjustments for Price Index Fluctuations."

To "Opt Out" the "Opt Out of Payment Adjustment for Price Index Fluctuations" form provided in the Bid Book must be completely filled in, dated, signed, and submitted with the Bid documents. If this form is not submitted with the Bid documents, or if this form is not completely filled in, dated, signed, and submitted when the Bid documents are due, Bidder shall be subject to the Payment Adjustments for Price Index Fluctuations set forth in Standard Specifications Section 9-1.07 "Payment Adjustments for Price Index Fluctuations."

6. Interpretation of Documents

Discrepancies, errors, omissions, ambiguities, requirements likely to cause disputes between trades and similar matters must be promptly brought to the attention of the County in writing. When appropriate, addenda will be issued by the County.

If the Bidder requires clarification or interpretation of the bidding Contract Documents, the Bidder must make a written request to the County by a Request for Information (RFI). All RFIs must be submitted in writing between the hours of 8:00 a.m. and 5:00 p.m. , Monday through Friday (except County-overserved holidays), up to, including and no later than the fifth (5<sup>th</sup>) business day prior to the bid closing deadline, by hand delivery, mail, fax or electronic mail. The County will not respond to RFIs submitted after that time, unless the County determines at its sole discretion that it is in the best interest of the public and the County to do so. RFIs should be addressed and sent to:

County of Riverside  
Transportation Department  
Attention: Contracts/Bidding Unit  
3525 14<sup>th</sup> Street  
Riverside, CA 92501

Facsimile: (951) 955-3164  
Electronic mail: [jrjimenez@rivco.org](mailto:jrjimenez@rivco.org)  
and/or  
[Bids-Contracts@rivco.org](mailto:Bids-Contracts@rivco.org)

Any communication by anyone as to RFIs and other project document inquiries, except by Addenda, does not affect the meaning or requirements of the Contract Documents.

7. Quantities

The amount of work to be done and/or materials to be furnished under the Contract, as shown in the Bid form, are merely estimates and are not to be taken as an expressed or implied statement that the actual amount of work or materials will correspond to the estimate.

County reserves the right to increase, decrease or entirely eliminate any items from the work and/or materials to be furnished.

Bidders are cautioned against the unbalancing of their bid by prorating project overhead costs only into one, two, or few items when there are various items listed in the bid schedule(s).



8. Addenda

County reserves the right to issue Addenda to the Contract Documents at any time prior to the scheduled bid opening date and time. Each potential Bidder must provide the County his company name, contact name, phone number, facsimile number, electronic mail address and company address for the purpose of receiving Addenda.

To be considered responsive, the Bid must list and take into account all issued Addenda.

In addition to listing the acknowledged addenda (if any) on the Bid, Bidders should submit each addendum's acknowledgement signature page and attach each one to the Bid. Attaching all addenda pages and attachments (if any) to the Bid submittal is not necessary for Bid submittal. All Addenda is a component of the Contract Documents.

9. License

To be considered for award of the Contract, a Bidder must have the necessary license(s) required under provisions of the California Business and Professions Code for the scope of work covered in the Contract Documents at the time of bid submission. This includes Joint Ventures.

Each item of work will be performed by a Contractor that is qualified and properly licensed for that work.

Pursuant to California Labor Code §3099, certification is required for all persons who perform work as electricians for Contractors licensed as Class C10 "Electrical Contractor." Proof of certification must be provided to the County before the start of construction.

10. Contract Participation

County encourages general and prime Contractors to solicit competitive subcontracting, trucking and supplier opportunities to minority, women, disabled veteran, and small business firms where possible, in their contracting and procurement activities with the County.

Section 3-1.08, "Small Business Participation Report," of the Standard Specifications is deleted.

11. Subletting, Subcontracting, and Subcontractor List

General

Attention is directed to General Conditions Section 12, "Subcontracting."

Pursuant to Public Contract Code § 4100 et seq., “Subletting and Subcontracting Fair Practices Act,” Bidders are required to list each subcontractor who will perform work, provide labor, or render services in or about the construction of work or improvement or a subcontractor who specifically fabricates and installs a portion of the work or improvement according to the details contained in the Plans and Specifications. The Subletting and Subcontracting Fair Practice Act applies to all phases of the work.

Subcontractor List

The Bidder must submit a Subcontractor List when subcontracting is utilized. Subcontractor List must be on the form contained in the Bid Book.

Section 2-1.10, “Subcontractor List” of the Standard Specifications is deleted and replaced with the following:

Bidder must list each subcontractor to perform work, labor or render service in or about the construction in an amount in excess of 1/2 of 1 percent of the total bid or \$10,000, whichever is greater (Public Contract Code § 4100 et seq.).

Pursuant to Public Contract Code § 6109 et seq., the Contractor shall not perform work on a project with a subcontractor who is ineligible to perform work on the project pursuant to Labor Code § 1777.1 or 1777.7.

The Subcontractor List must show the business name, business address, license number, DIR registration number and work portions to be performed by each subcontractor listed. Work portions must be identified by bid item number and description for each subcontractor listed. The percentage of work to be performed by all listed subcontractors must be written on the bottom of the Subcontractor List form.

An inadvertent error in listing the license number will be processed as required by Public Contract Code § 4104 (a) (2). If partial work is to be performed within a certain construction item or trade, the Bidder/Contractor shall specify the portions of the work to be performed by the different subcontractors or the directive under Public Contract Code § 4106 shall apply.

Each designated item of work will be performed by a Contractor who is qualified and properly licensed for that listed item of work.

Omission or failure to list a subcontractor for a portion of the work means that the prime Contractor will do that portion of the work (Public Contract Code § 4106).

The County may request additional information to verify submitted Subcontractor List information and for total and/or individual subcontracted percentage amounts. Bidder must provide this information within three (3) business days after the bid opening date.

Penalties

The Bidder's attention is directed to other provisions of the Subletting and Subcontracting Fair Practices Act related to the imposition of penalties for failure to observe its provisions by utilizing unauthorized subcontractors or by making unauthorized substitutions.

Clerical error

After the Bid Opening, inadvertent subcontractor designation clerical error(s) will be processed as required by Public Contract Code § 4107.5 and as required by Labor Code §1771.1 (c) for subcontractors who are not registered with the DIR.

12. Registration with the Department of Industrial Relations (DIR)

Attention is directed to:

- Notice to Bidder's regarding Labor Code requirements
- General Conditions Section 8, "Labor Code"

No Contractor may submit a bid nor a subcontractor be listed on a bid (submitted on or after March 1, 2015) unless registered with the Department of Industrial Relations pursuant to Labor Code § 1725.5 or excepted from this requirement for bid purposes only under Labor Code § 1771.1(a).

No Contractor or subcontractor may be awarded a Contract (awarded on or after April 1, 2015) or perform work on any contract for public work unless registered with the Department of Industrial Relations pursuant to Labor Code Section 1725.5.

This project is subject to compliance monitoring and enforcement by the DIR.

13. Hours of Work

Attention is directed to Section 8-1.05, "Time" and Section 7-1.02K(5), "Working Hours" of the Standard Specifications.

Daily working hours will be between the hours of **7:00 a.m. and 6:00 p.m.**, Monday through Friday, except County-overserved holidays, or as revised in the Special Provisions, and as approved by the Engineer. Exceptions and specific work schedules must be submitted in writing to the Engineer for consideration.

14. Alternate Bid Schedules

If the Bid includes bid items listed under a Base Bid Schedule and one or more Alternate Bid Schedules, the following will apply:

The County may award only the items of work listed on the Base Bid Schedule, or may choose to award some or all of the Alternate Bid Schedules in addition to the Base Bid Schedule. Unless otherwise specified, the basis of the selection of the lowest bid will be the lowest responsive and responsible bid for the sum of all Bid Schedules.

If the Bid includes bid items listed under two or more Alternate Bid Schedules with no Base Bid Schedule, the following will apply:

This project contains Alternate Bid Schedules that may or may not be mutually exclusive, as described elsewhere in the bid documents. The County may award the items of work listed on one or more of the Alternate Bid Schedules. In the case of mutually exclusive Alternate Bid Schedules, only one of the Alternate Bid Schedules will be selected for award. Unless otherwise specified, the basis of the selection of the lowest bid will be the lowest responsive and responsible bid for the sum of all Bid Schedules.

The County reserves the right to reject all bids received.

#### 15. Bids

No Bidder may withdraw their bid for a period of ninety (90) calendar days after the bid opening.

The County publicly opens and reads bids at the time and place shown on the Notice to Bidders.

Bids are required for the entire work, including all alternate bid schedules, if applicable, unless otherwise explicitly allowed in the bid documents. The amount of the bid, for comparison purposes, will be the total of all items. The total of unit basis items will be determined by extension of the item price bid on the basis of the estimated quantity set forth for the item.

The Bidder must set forth for each item of work in clearly legible figures, an item price and a total for the item in the respective spaces provided for this purpose. In the case of unit basis items, the amount set forth under the "Total" column will be the extension of the item price bid on the basis of the estimated quantity for the item.

In the case of a discrepancy between the unit price and the total set forth for a unit basis item, the unit price will prevail, in (1) or (2), as follows:

1. If the amount set forth as a unit price is unreadable or otherwise unclear, or is omitted, or is the same as the amount as the entry in the item "Total" column, then the amount set forth in the item "Total" column for the item shall be divided by the estimated quantity for the item and the price thus obtained will be the unit price.
2. (Decimal Errors) If the product of the entered unit price and the estimated quantity is exactly off by a factor of ten, one hundred, etc., or one-tenth, or one-hundredth, etc.

from the entered total, the discrepancy will be resolved by using the entered unit price or item total, whichever most closely approximates percentage-wise the unit price or item total in the County's final estimate of cost.

If both the unit price and the item total are unreadable or otherwise unclear, or are omitted, the bid may be deemed irregular. Likewise if the item total for a Lump Sum item is unreadable or otherwise unclear, or is omitted, the bid may be deemed irregular unless the project being bid has only a single item and a clear, readable total bid amount is provided.

Symbols such as commas and dollar signs will be ignored and have no mathematical significance in establishing any unit price or item total or Lump Sums. Written unit prices, item totals and Lump Sums will be interpreted according to the number of digits and, if applicable, decimal placement. Cents symbols also have no significance in establishing any unit price or item total since all figures are assumed to be expressed in dollars and/or decimal fractions of a dollar.

Bids on Lump Sum items shall be item totals only; if any unit price for a Lump Sum item is included in a bid and it differs from the item total, the items total shall prevail.

The foregoing provisions for the resolution of specific irregularities cannot be so comprehensive as to cover every omission, inconsistency, error or other irregularity which may occur in a bid. Any situation not specifically provided for will be determined in the discretion of the County, and that discretion will be exercised in the manner deemed by the County to best protect the public interest in the prompt and economical completion of the work. The decision of the County respecting the amount of a bid, or the existence or treatment of an irregularity in a bid, including determination of non-responsiveness, shall be final.

The County hereby reserves the right to reject any and all bids, to waive any irregularity, and to award the Contract to other than the lowest Bidder.

#### 16. Like Bid Items

The Bidder is advised that the items of work may be grouped into bid schedules, and that certain bid items may be listed in more than one bid schedule, and listed with different bid item numbers, and the following will apply thereto:

The Bidder is directed to submit the same bid amount for all bid items that are listed with the same item code and item description. Said bid items are referred to herein as "Like Bid Items."

"Like Bid Items" will be considered a single bid item for purposes of calculating increased and decreased quantities, and as otherwise applicable in Section 4-1.05, "Changes and Extra Work" of the Standard Specifications.

The following are not subject to this bidding requirement:

1. Bid items with the same item code but different item descriptions.
2. Bid items that are measured as “Lump Sum” or “Force Account.”
3. Alternate Bid Schedules.

In the event that a Bidder submits different unit bid amounts for “Like Bid Items,” as described above, the bid will be corrected by applying the lowest of the unit bid amounts to all the respective “Like Bid Items.”

#### 17. Contract Documents

The complete Contract Documents are identified in the Contract. Potential Bidders are cautioned that the successful Bidder incurs duties and obligations under all of the Contract Documents and that they should not merely skim and hastily review the Plans and Specifications in making their bid.

#### 18. Submission of Bidder’s Bid

A Bidder’s Bid must be submitted in a sealed opaque envelope that clearly identifies the Bidder’s name and the project name. Bids must be received before the scheduled date and time at the location set forth in the Notice to Bidders and may be withdrawn only as stated in the Bid. Bids must be completed in ink.

#### 19. Qualifications of Bidders

No award will be made to any Bidder who cannot give satisfactory assurance to the Board of Supervisors as to his own ability to carry out the Contract, both from his financial standing and by reason of his previous experience as a Contractor on work of the nature contemplated in the Contract. The Bidder may be required to submit his record of work of similar nature to that proposed under these specifications and unfamiliarity with the type of work may be sufficient cause for rejection of bid.

#### 20. Award of Contract

The Bidder's attention is directed to the provisions in these Instructions to Bidders for the requirements and conditions concerning award and execution of Contract.

Section 3-1.04, “Contract Award” of the Standard Specifications is deleted.

Section 3-1.02B, “Tied Bids” introduction sentence, “The Department breaks a tied bid with a coin toss except:” is deleted and replaced with:

“The County may select one of any number of tied bids by its desired choice (Public Contract Code § 22038.b) and:”

The award of the Contract, if it be awarded, will be to the lowest responsible Bidder whose bid complies with all the requirements prescribed.

The County reserves the right to reject all bids received.

Acceptance, by the governing body of the County by resolution or minute order at a meeting regularly called and held, of a Bid constitutes an award of the Contract and the execution of the Contract is a written memorial thereof.

The County will submit the Contract Documents to the low responsive and responsible Bidder for execution prior to award utilizing the following procedures and requirements:

- A. A Bidder whose Bid is accepted must execute the formal construction Contract with the County, similar to the form attached hereto as a sample, and must return said Contract, together with approved Performance Bond and Payment Bond and with complete evidence of insurance as required elsewhere herein, including executed additional insured endorsements and waivers of subrogation, within ten (10) business days from the date of the Notice of Acceptance of Bid and Intent to Award as issued by the Transportation Department. All submittals must meet the requirements of the bid documents. Corrections, if required, must be made and the revised documents must be resubmitted within two (2) business days of Contractor's receipt of review comments.
- B. The bonds and insurance documentation must be submitted in accordance with the Contract Document requirements prior to submission to the County of Riverside Board of Supervisors for award by the Transportation Department and prior to the performance of any work under the Contract.
- C. If a Bidder to whom a Notice of Acceptance of Bid and Intent to Award has been issued, fails or refuses to sign a construction Contract, or to furnish the bonds or insurance certificates and endorsements as required within the prescribed period of time as described above, the County may, at its sole discretion, rescind the Notice of Acceptance, and the bid guarantee submitted by that Bidder will become the property of the County as prescribed in the bid documents and as allowed by law.
- D. If it is in the best interest of the County, the County reserves the right to award the Contract prior to execution by the Contractor. Thereafter, County will mail or deliver the County signed Contract to the awarded Contractor for execution and return.

Bid Protest

Any Bidder submitting a bid to County may file a protest of the County's proposed Award of the Contract provided that each and all of the following are complied with:

1. The bid protest is in writing.
2. The bid protest is filed with and received by County of Riverside Transportation and Land Management Agency at the following address:

County of Riverside  
Transportation Department  
Attention: Contracts/Bidding Unit  
3525 14th Street  
Riverside, CA 92501

Facsimile: (951) 955-3164  
Electronic mail: [jrjimenez@rivco.org](mailto:jrjimenez@rivco.org)

3. The bid protest is filed with and received not more than five (5) calendar days following the date of issuance of the Notice of Intent to Award. Notice of Intent to Award letter is posted on the County of Riverside Transportation Department website along with the project bid summary. URL for this webpage is <http://rctlma.org/trans/Contractors-Corner/Bid-Summaries>. Failure to timely file and serve the bid protest as aforesaid shall constitute grounds for the County's denial of the bid protest without consideration of the grounds stated therein.
4. The written bid protest sets forth, in detail, all grounds for the bid protest, including without limitation all facts, supporting documentation, legal authorities and argument in support of the grounds for the bid protest. Any grounds not set forth in the bid protest shall be deemed waived. All factual contentions must be supported by competent, admissible and credible evidence. Any bid protest not conforming to the foregoing shall be rejected as invalid.
5. Provided that a bid protest is filed in conformity with the foregoing, the Director of TLMA, or such individual(s) as may be designated by the Director in his discretion, shall review and evaluate the basis of the bid protest, and shall provide a written decision to the Bidder submitting the bid protest, either concurring with or denying the bid protest. The written decision of the Director or his designee shall be final, unless overturned by the Board of Supervisors.

21. Payment and Performance Bonds

The County requires a 100% Payment Bond and 100% Performance Bond from the successful Bidder. All bonds must be on County's forms contained in the Bid Book.



The bonds must be underwritten by a Surety Company, which is admitted to transact the business of insurance in the State of California, and which carries a rating in the current issue of Best's Insurance Guide of "A" or better with a financial size of at least "VIII". The bond forms included in the Bid Book must be used. All signatures on the bonds must be notarized. Bonds must be provided with an executed Power of Attorney issued by the Surety.

22. Return of Bid Guarantee

Standard Specification Section 3-1.19, "Bidder's Securities" is deleted.

Bid bonds will not be returned unless specifically requested by the Bidder in writing. Any submitted negotiable securities of unsuccessful Bidders will be returned by mail within 30 days of the award of a contract to the successful Bidder. Any submitted negotiable security of the successful Bidder will be returned by mail within 30 calendar days of acceptable receipt of executed Contract, certificate of insurance, Performance Bond and Payment Bond.

23. Submission of Insurance Certificate and Endorsements

Attention is directed General Conditions Section 4, "Insurance and Hold Harmless."

Within ten (10) working days of the date of the Notice of Acceptance of Bid and Intent to Award issued by the County, the successful Contractor must submit a certificate of insurance, including required endorsements, which provides evidence that the bidding Contractor has insurance coverage that meets the requirements of General Conditions "Insurance and Hold Harmless" section. Failure to have complete insurance coverage in place and to provide all required certificates and endorsements within the specified ten (10) business day period will be grounds to declare the Bidder as non-compliant with the bid documents, rescinding the Notice of Acceptance, making a claim against the bid bond, and awarding to the second low Bidder, at the sole discretion of the County.



Mark Lancaster, P.E.  
Director of Transportation

# COUNTY OF RIVERSIDE

## TRANSPORTATION AND LAND MANAGEMENT AGENCY

Mojahed Salama, P.E.  
Deputy for Transportation/  
Capital Projects

Russell Williams  
Deputy for Transportation/  
Planning and Development

### Transportation Department

#### ADDENDUM NUMBER 1

Dated June 28, 2023

to the  
Specifications and Contract Documents  
for the construction of

Johnston Avenue Resurfacing  
San Jacinto Street to 630-Foot East of Stanford Street  
Community of East Hemet  
Project No. B0-0612

**Bids Due: Wednesday, July 5, 2023; 2:00 p.m.**  
14<sup>th</sup> Street Transportation Annex  
3525 14<sup>th</sup> Street; Riverside, CA 92501  
(951) 955-6780

This Addendum is issued pursuant to the Instructions to Bidders, Item No. 8, of the Contract Documents for the reference project. This Addendum is issued as a supplement to the specification and special provisions for the referenced project. The revisions to the specifications shall become a part of the Contract Documents, and each bidder shall acknowledge receipt thereof on the Bid (Proposal). Bidders are directed to sign this addendum as acknowledged and attach the signed addendum to the contractor's submitted proposal.

Note: During the advertisement period of this project, this document and attachments (if any) are available upon request at the office of the Transportation Department, and are available as a free download at the Transportation Department's website:

<https://trans.rctlma.org/notices-inviting-bids>

#### MODIFICATIONS / CLARIFICATIONS TO SPECIAL PROVISIONS:

**Item 1: Revised Proposal**

Refer to "Proposal" pages B2-B4. Delete and replace "Proposal" (pages B2-B4) with "Proposal (Revised)" attached herewith as **Attachment "A"**.

**Note: Revisions made to the proposal by Addendum No. 1 are written with blue font/numbers in Attachment "A".**

- a. Item description and quantity has been revised for the following item:  
Item 16, ADJUST UTILITY COVER TO GRADE [WATER METER, LHMWD]

**Item 2: Adjust Existing Water Meter Boxes To Grade.**

Refer to Section 71-8, "Adjust Existing Water Meter Boxes To Grade (Including Installing Traffic Rated Cover)," on pages 50 and 51 of the special provisions. Delete Section 71-8 and replace it with the following:

**71-8 ADJUST EXISTING WATER METER BOXES TO GRADE**

**71-8.01 GENERAL**

**71-8.01A General**

**71-8.01(1) Summary**

Section 71-8 includes specifications for adjusting existing Lake Hemet Municipal Water District (LHMWD) water meter boxes to grade.

Contractor shall comply with the applicable LHMWD special provisions and standard plans.

**71-8.02 Materials**

Existing water meter boxes shall be adjusted to finished grade with materials similar in quality to those in the original structure in accordance with these Special Provisions.

Water meter boxes must comply with all requirements of LHMWD standard specifications and plans and as directed by Engineer.

Contractor must provide coordination with LHMWD for all work associated with their facilities.

**71-8.03 Construction**

All work shall be performed by a Licensed and qualified plumber.

The Contractor shall furnish and install all required materials and equipment needed to complete the work specified herein.

The contractor will make all connections to existing water line.

Attention is directed to Section 00-1.10, Cooperation, of these Special Provisions for fully cooperation with LHMWD. The contractor must cooperate with LHMWD in performing the work required to make the connection to the existing water line including but not limited to providing materials, excavation, traffic control, and backfill, in conformance with the Standard Specifications, these Special Provisions and as directed by the Engineer.

**71-8.04 Payment**

The contract unit bid price paid per each for Adjust Utility Cover To Grade [Water Meter, LHMWD] shall include full compensation for furnishing all labor, materials, tools, equipment, and incidentals, for doing all the work involved and no additional compensation will be allowed therefor.

**MODIFICATIONS / CLARIFICATIONS TO THE PLANS:**

**Item 3: Plan sheet revisions.**

Refer to plans for Johnston Avenue Resurfacing, San Jacinto Street to 630-Feet East of Stanford Street, Community of East Hemet, Project No. B0-0612. The following plans modifications are reflected on the revised construction plans attached herewith as **Attachment "B"**.

- **Construction Note 16.** Refer to plans sheets 3, 4, 6 and 7 of 17. Original construction note 16, "ADJUST WATER METER TO GRADE AND INSTALL TRAFFIC RATED COVER PER LHMWD STANDARDS" is deleted and replaced with:

**16 ADJUST WATER METER TOR GRADE PER LHMWD STANDARDS**

- **Replace callout note 16 at various locations.** Refer to plans sheets 4, 5 and 7 of 17. Original callout notes No. 16 found at the following approximate locations on Johnston Avenue are replaced with callout notes No. 1 for "PROTECT"

**On Sheet 4 of 17, L-1**

<u>At approximately station</u>	<u>Side</u>
27+90	North
37+40	South

**On Sheet 5 of 17, L-2**

<u>At approximately station</u>	<u>Side</u>	<u>At approximately station</u>	<u>Side</u>
38+05	South	44+05	North
38+35	North	44+45	North
39+40	North	44+65	South
40+05	North	45+10	North
40+30	South	45+75	North
40+70	North	46+50	North
41+15	South	46+70	South
41+20	North	47+45	North
41+90	North	47+80	South
42+60	North	48+30	North
43+40	North	50+55	South
43+95	South	51+30	South

**On Sheet 7 of 17, L-4**

<u>At approximately station</u>	<u>Side</u>	<u>At approximately station</u>	<u>Side</u>
78+50	South	81+50	North
79+00	North	81+60	South
79+30	South	82+30	South
79+60	North	82+55	North
79+90	South	82+65	North
80+65	South	84+75	North

• **Delete and replace** the following five (5) plans sheets from the set:

1. Plan sheet 3 of 17, X-1
2. Plan sheet 4 of 17, L-1
3. Plan sheet 5 of 17, L-2
4. Plan sheet 6 of 17, L-3
5. Plan sheet 7 of 17, L-4

Note: Revised plan sheet(s) is (are) posted on the County website and available for download during the advertisement period.

<https://trans.rctlma.org/notices-inviting-bids>

**ATTACHMENTS**

**A – Revised Proposal (3 sheets)**

**B – Revised Plan Sheets (5 sheets)**

Addendum No. 1  
Johnston Avenue Resurfacing  
San Jacinto Street to 630-Feet East of Stanford Street  
Community of East Hemet  
Project No. B0-0612  
June 28, 2023  
Page 5 of 5

---

This addendum has been prepared under the direction of the following registered Civil Engineer(s):

**Recommended by:**

*Mike Heath*

\_\_\_\_\_  
Mike Heath, PE  
Sr. Civil Engineer



**Concurrence:**

*Khalid Nasim*

\_\_\_\_\_  
Khalid Nasim, PE  
Engineering Division Manager

**Acknowledged:** \_\_\_\_\_ **Date:** \_\_\_\_\_  
(Contractor)

JRJ:jrj:jr

Note: Refer to Instruction to Bidders Item No. 8, "Addenda". Submission of all addendum pages and non-bidding document attachments of addendum are not necessary for Bid submittal. Submittal of this acknowledgement page is adequate for Bid reception. Bidders are reminded to list addendum number(s) received on the first page of the Bid form (Proposal).

**Johnston Avenue Resurfacing  
San Jacinto Street to 630-Foot East of Stanford Street  
Community of East Hemet  
Project No. B0-0612**

REVISED PROPOSAL

ITEM No.	ITEM CODE	ITEM	UNIT	ESTIMATED QUANTITY	ITEM PRICE (IN FIGURES)	TOTAL (IN FIGURES)
<b>BASE BID SCHEDULE - Johnston Avenue Resurfacing</b>						
1	100100	DEVELOP WATER SUPPLY	LS	1		
2	120100	TRAFFIC CONTROL SYSTEM	LS	1		
3	130200	PREPARE WATER POLLUTION CONTROL PROGRAM	LS	1		
4	170103	CLEARING AND GRUBBING	LS	1		
5	066100	DUST ABATEMENT	LS	1		
6	190101(F)	ROADWAY EXCAVATION	CY	5,300		
7	013903	PLACE ASPHALT CONCRETE DIKE (CRS 212) (6")	LF	95		
8	013904	PLACE ASPHALT CONCRETE DIKE (CRS 212) (8")	LF	95		
9	394075	PLACE HOT MIX ASPHALT DIKE (TYPE D) [PER CALTRANS STD A87B]	LF	1,900		
10	394075	PLACE HOT MIX ASPHALT DIKE (TYPE D) [PER CALTRANS STD A87B, MODIFIED TO 8" HEIGHT]	LF	550		
11	394076	PLACE HOT MIX ASPHALT DIKE (TYPE E) (PER CALTRANS STD. A87B)	LF	30		
12	390132	HOT MIX ASPHALT (TYPE A)	TON	11,500		
13	013905	ASPHALT CONCRETE (DRIVEWAY APPROACH WITH ASPHALT CONCRETE DIKE) (CRS 206)	SQFT	180		
14	013905	ASPHALT CONCRETE (DRIVEWAY APPROACH WITH ASPHALT CONCRETE DIKE) (CRS 206) [MODIFIED FOR MOUNTABLE DIKE]	SQFT	6,600		
15	013908	ASPHALT CONCRETE DRIVEWAY [3.5-INCH ON NATIVE]	SQFT	18,000		
16	710220	<b>ADJUST UTILITY COVER TO GRADE [WATER METER, LHMWD]</b>	EA	<b>15</b>		
17	710200	ADJUST MANHOLE [LHMWD]	EA	24		
18	710192	ADJUST SEWER CLEANOUT TO GRADE [LHMWD]	EA	2		
19	731516	MINOR CONCRETE (DRIVEWAY) [CRS 213]	SQFT	160		

Addendum No. 1, Page 6 of 13

**REVISED PROPOSAL**

ITEM No.	ITEM CODE	ITEM	UNIT	ESTIMATED QUANTITY	ITEM PRICE (IN FIGURES)	TOTAL (IN FIGURES)
<b>BASE BID SCHEDULE - Johnston Avenue Resurfacing (Continued)</b>						
20	731516	MINOR CONCRETE (DRIVEWAY) [MODIFIED FOR MOUNTABLE DIKE]	SQFT	1,400		
21	731516	MINOR CONCRETE (DRIVEWAY) [6-INCH ON NATIVE]	SQFT	950		
22	017301	MINOR CONCRETE (DRIVEWAY APPROACH WITH ASPHALT CONCRETE DIKE) (CRS 206) [MODIFIED FOR CURB AND GUTTER]	SQFT	550		
23	017304	MINOR CONCRETE (CURB AND GUTTER) (CRS 200)	LF	420		
24	017315	MINOR CONCRETE (CURB RAMP) (CRS 403 - CASE A)	EA	4		
25	017316	MINOR CONCRETE (CURB RAMP) (CRS 403 - CASE B) [MODIFIED PER PLAN]	EA	2		
26	017317	MINOR CONCRETE (CROSS-GUTTER AND SPANDREL) (CRS 209)	SQFT	4,100		
27	510502	MINOR CONCRETE (MINOR STRUCTURE) [CRS 308, MODIFIED FOR REVERSE FLOW INLET, WIDTH = 4']	EA	1		
28	011503	UNDER SIDEWALK DRAIN CAST IN PLACE (CRS 309)	EA	1		
29	731507	MINOR CONCRETE (GUTTER DEPRESSION)	EA	1		
30	731521	MINOR CONCRETE (SIDEWALK) [AND 4' WALKWAYS]	SQFT	670		
31	782110	RESET MAILBOX [OR RELOCATE MAILBOX]	EA	15		
32	810230(F)	PAVEMENT MARKER (RETROREFLECTIVE)	EA	310		
33	820250	REMOVE ROADSIDE SIGN [AND SALVAGE]	EA	22		
34	820840	ROADSIDE SIGN - ONE POST	EA	22		
35	840656(F)	PAINT TRAFFIC STRIPE (2-COAT)	LF	14,500		
36	840519	THERMOPLASTIC CROSSWALK AND PAVEMENT MARKING	SQFT	675		
37	010602	MISCELLANEOUS WORK (AS DIRECTED)	FA	1	<b>200,000.00</b>	<b>200,000.00</b>

Addendum No. 1, Page 7 of 13

BASE BID SCH.

TOTAL: \_\_\_\_\_

ITEMS 1-37

"WORDS" \_\_\_\_\_

\$ \_\_\_\_\_



**REVISED PROPOSAL**

ITEM No.	ITEM CODE	ITEM	UNIT	ESTIMATED QUANTITY	ITEM PRICE (IN FIGURES)	TOTAL (IN FIGURES)
----------	-----------	------	------	--------------------	-------------------------	--------------------

**ALTERNATIVE BID SCHEDULE 1 - EMWD Manhole Adjustments**

38	710200	ADJUST MANHOLE [EMWD]	EA	5		
----	--------	-----------------------	----	---	--	--

ALT. BID SCH. 1

TOTAL: \_\_\_\_\_ \$ \_\_\_\_\_  
ITEM 38 "WORDS"

**BASE BID SCH. + ALT. BID SCH. 1**

PROJECT  
TOTAL: \_\_\_\_\_ \$ \_\_\_\_\_  
ITEMS 1 - 38 "WORDS"

Addendum No. 1, Page 8 of 13

**CONSTRUCTION NOTES:**

- 1 PROTECT R/W
- 2 MATCH EXISTING
- 3 SAWCUT
- 4 REMOVE EXISTING AC BERM AND/OR DIKE
- 5 REMOVE AND RECONSTRUCT CURB AND GUTTER PER COUNTY OF RIVERSIDE STD NO. 200, TYPE A-6
- 6 ADJUST GAS VALVE TO GRADE BY CONTRACTOR
- 7 ADJUST SEWER CLEANOUT TO GRADE BY CONTRACTOR PER LHMD STANDARDS
- 8 ADJUST SEWER MANHOLE TO GRADE BY CONTRACTOR PER LHMD STANDARDS
- 9 ADJUST SEWER MANHOLE TO GRADE BY EMD
- 10 CONSTRUCT 6" ASPHALT CONCRETE DIKE PER COUNTY OF RIVERSIDE STD NO. 212, TYPE 6"
- 11 CONSTRUCT 8" ASPHALT CONCRETE MOUNTABLE DIKE PER CALTRANS STD NO. 487B, TYPE D
- 12 CONSTRUCT ASPHALT CONCRETE MOUNTABLE DIKE PER COUNTY OF RIVERSIDE STD NO. 212, TYPE 6"
- 13 CONSTRUCT ASPHALT CONCRETE MOUNTABLE DIKE PER COUNTY OF RIVERSIDE STD NO. 212, TYPE 6" HEIGHT PER "MODIFIED 8" MOUNTABLE DIKE DETAIL" ON SHEET C-1
- 14 REMOVE AND RECONSTRUCT ASPHALT CONCRETE DRIVEWAY PER COUNTY OF RIVERSIDE STD NO. 206 (ON NATIVE)
- 15 REMOVE AND RECONSTRUCT ASPHALT CONCRETE DRIVEWAY PER COUNTY OF RIVERSIDE STD NO. 213
- 16 REMOVE AND RECONSTRUCT ASPHALT CONCRETE DRIVEWAY PER COUNTY OF RIVERSIDE STD NO. 209
- 17 REMOVE 0.45' OF EXISTING ASPHALT CONCRETE AND BASE
- 18 CONSTRUCT 0.20" HMA TYPE "A" PG 64-10 3/4" MIX OVER 0.25" HMA TYPE "A" PG 64-10 1" MIX
- 19 REMOVE AND RECONSTRUCT CURB RAMP PER COUNTY OF RIVERSIDE STD NO. 403, CASE A
- 20 REMOVE AND RECONSTRUCT UNDER SIDEWALK DRAIN PER COUNTY OF RIVERSIDE STD NO. 309
- 21 CONSTRUCT CURB AND GUTTER PER COUNTY OF RIVERSIDE STD NO. 200, TYPE A-6
- 22 REMOVE AND RECONSTRUCT CONCRETE SIDEWALK PER COUNTY OF RIVERSIDE STD NO. 401
- 23 CONSTRUCT 4" ASPHALT CONCRETE DIKE PER CALTRANS STD NO. 487B, TYPE E
- 24 RELOCATE/RESET EXISTING MAILBOX PER PLAN
- 25 CONSTRUCT CONCRETE DRIVEWAY PER COUNTY OF RIVERSIDE STD NO. 206 (ON NATIVE AND MODIFIED FOR MOUNTABLE DIKE) (SEE DETAIL ON C-1 FOR SWALE CONDITION)
- 26 CONSTRUCT CONCRETE DRIVEWAY PER COUNTY OF RIVERSIDE STD NO. 206 (ON NATIVE AND MODIFIED FOR MOUNTABLE DIKE)
- 27 PLACE SAFETY EDGE PER "SAFETY EDGE" DETAIL ON SHEET C-1
- 28 CONSTRUCT 10" AC DIKE TO AC MOUNTABLE DIKE TRANSITION PER AC DIKE TO AC MOUNTABLE DIKE TRANSITION DETAIL" ON SHEET C-1
- 29 REMOVE AND RECONSTRUCT ASPHALT CONCRETE DRIVEWAY PER COUNTY OF RIVERSIDE STD NO. 206, MODIFIED FOR "MOUNTABLE DIKE DRIVEWAY DETAIL" ON SHEET C-1
- 30 REMOVE AND RECONSTRUCT CONCRETE DRIVEWAY PER COUNTY OF RIVERSIDE STD NO. 206, MODIFIED PER "MOUNTABLE DIKE DRIVEWAY DETAIL" ON SHEET C-1
- 31 REMOVE AND RECONSTRUCT 4" WIDE CONCRETE WALKWAY (4" THICK)
- 32 REMOVE AND RECONSTRUCT CURB INLET STRUCTURE PER COUNTY OF RIVERSIDE STD NO. 308 (MODIFIED FOR REVERSE FLOW INLET AND PER DETAIL ON C-1, WIDTH = 4')
- 33 CONSTRUCT GUTTER DEPRESSION PER COUNTY OF RIVERSIDE STD NO. 311 (CASE C)
- 34 RE-ESTABLISH TREE WELL IN DRIVEWAY
- 35 CONSTRUCT CURB RAMP PER COUNTY OF RIVERSIDE STD NO. 403, CASE B (MODIFIED PER PLAN)
- 36 REMOVE AND RECONSTRUCT ASPHALT CONCRETE DRIVEWAY PER COUNTY OF RIVERSIDE STD NO. 206 (MODIFIED FOR MOUNTABLE DIKE)
- 37 REMOVE AND RECONSTRUCT ASPHALT CONCRETE DRIVEWAY (3.5" THICK ON NATIVE) (SEE DETAIL ON C-1 FOR SWALE CONDITION)
- 38 REMOVE AND RECONSTRUCT CONCRETE DRIVEWAY PER COUNTY OF RIVERSIDE STD NO. 206 (MODIFIED FOR MOUNTABLE DIKE)
- 39 REMOVE AND RECONSTRUCT CONCRETE DRIVEWAY (6" THICK ON NATIVE) (SEE DETAIL ON C-1 FOR SWALE CONDITION)
- 40 CONSTRUCT ASPHALT CONCRETE DRIVEWAY (3.5" ON NATIVE) (SEE DETAIL ON C-1 FOR SWALE CONDITION)
- 41 REMOVE AND RECONSTRUCT DRIVEWAY PER COUNTY OF RIVERSIDE STD NO. 206 (MODIFIED FOR CURB AND GUTTER)
- 42 CONSTRUCT DIRT SWALE PER DETAIL ON C-1

DATE PLOTTED: 08-14-20  
 TIME PLOTTED: 10:02 AM  
 PLOTTER: HP  
 SHEET: 3 OF 17

ISSUED BY ADDENDUM NO. 1, ATTACHMENT B

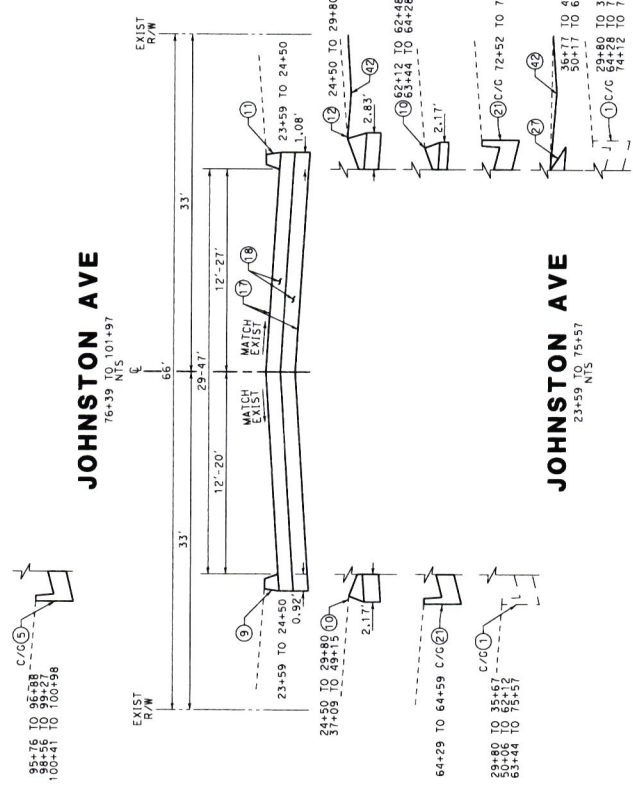
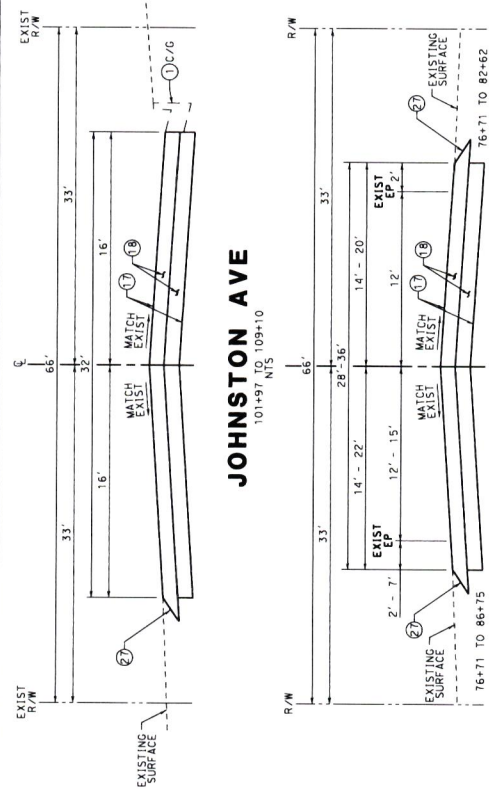

**HOR ENGINEERING, INC.**  
 PREPARED UNDER THE SUPERVISION OF:  
  
 CHARLES CHRISTOPOLIS  
 REGISTERED PROFESSIONAL ENGINEER  
 HIGHWAY PROJECT MANAGER  
 DATE

THE PRIVATE ENGINEER SIGNING THESE PLANS IS RESPONSIBLE FOR ASSURING THE ACCURACY AND CREDIBILITY OF THE DESIGN HEREON. IN THE EVENT OF DISCREPANCIES ARISING AFTER CONTRACT AWARD, THE CONTRACTOR SHALL BE RESPONSIBLE FOR VERIFYING THE DIMENSIONS AND FOR DETERMINING AN ACCEPTABLE SOLUTION AND REVISING THE PLANS FOR APPROVAL BY THE COUNTY.

**TYPICAL CROSS SECTIONS**  
**JOHNSTON AVENUE**  
**RESURFACING**  
 NO SCALE

**SHEET No. X-1**  
 SHEET 3 OF 17

USERNAME: WJESR  
 DON FILE: WJESR  
 COUNTY FILE NO. 973-A  
 NO. 80-0612

BORDER LAST REVISED 09/2017

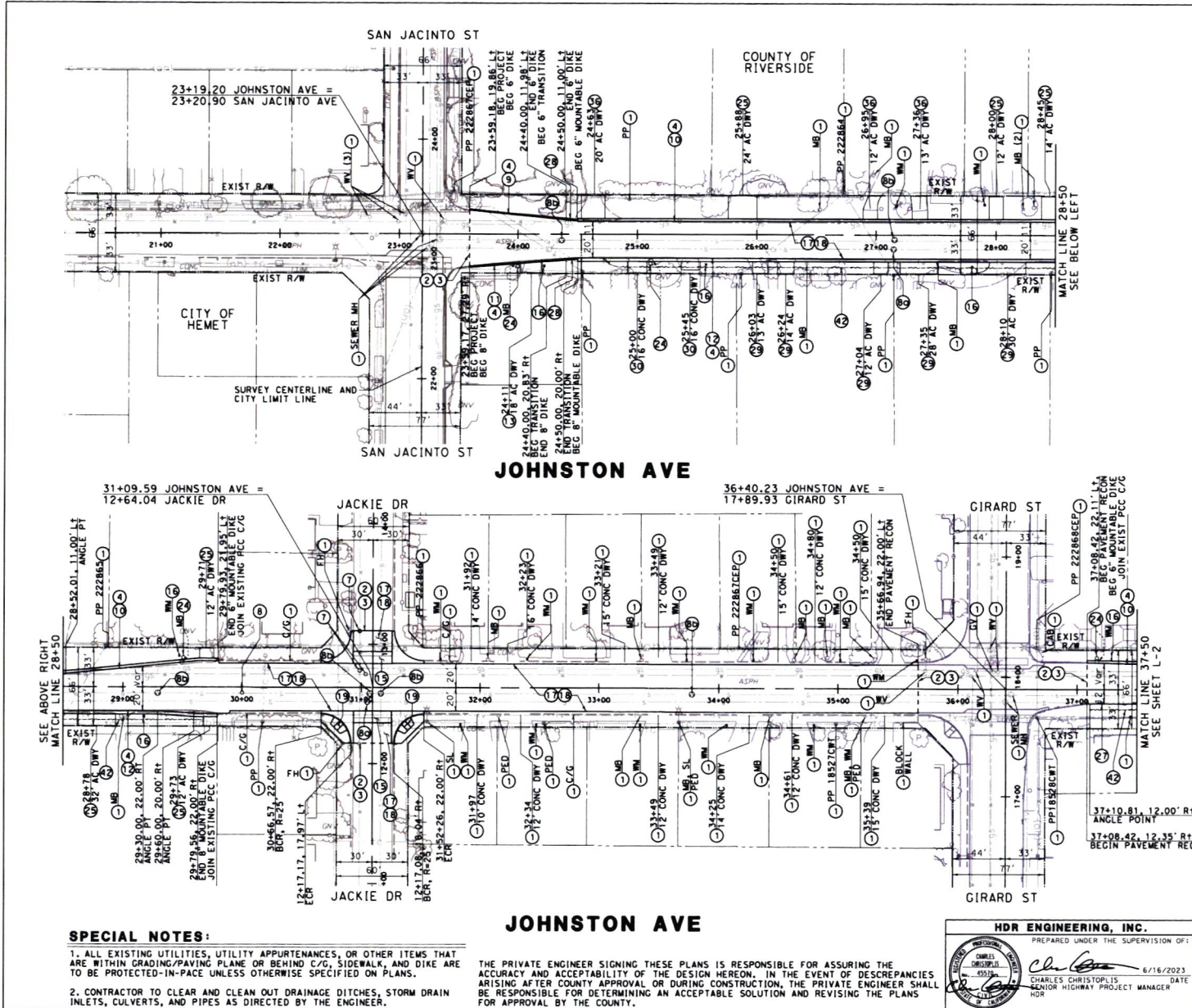

- CONSTRUCTION NOTES:**
- 1 PROTECT
  - 2 MATCH EXISTING
  - 3 SAWCUT
  - 4 REMOVE EXISTING AC BERM AND/OR DIKE
  - 5 ADJUST WATER VALVE TO GRADE BY CONTRACTOR PER LHMWD STANDARDS
  - 6 ADJUST SEWER CLEANOUT TO GRADE BY CONTRACTOR PER LHMWD STANDARDS
  - 7 ADJUST SEWER MANHOLE TO GRADE BY EMMWD
  - 8 ADJUST SEWER MANHOLE TO GRADE BY CONTRACTOR PER LHMWD STANDARDS
  - 9 CONSTRUCT 6" ASPHALT CONCRETE DIKE PER COUNTY OF RIVERSIDE STD No. 212, TYPE 6"
  - 10 CONSTRUCT 6" ASPHALT CONCRETE MOUNTABLE DIKE PER CALTRANS STD No. A87B, TYPE D
  - 11 CONSTRUCT 8" ASPHALT CONCRETE DIKE PER COUNTY OF RIVERSIDE STD No. 212, TYPE 8"
  - 12 CONSTRUCT ASPHALT CONCRETE MOUNTABLE DIKE PER CALTRANS STD No. A87B, TYPE D MODIFIED TO 8" HEIGHT PER "MODIFIED 8" MOUNTABLE DIKE DETAIL" ON SHEET C-1
  - 13 REMOVE AND RECONSTRUCT ASPHALT CONCRETE DRIVEWAY PER COUNTY OF RIVERSIDE STD No. 206 (ON NATIVE)
  - 14 REMOVE AND RECONSTRUCT CROSS GUTTER AND SPANDREL PER COUNTY OF RIVERSIDE STD No. 209
  - 15 ADJUST WATER METER TO GRADE PER LHMWD STANDARDS
  - 16 REMOVE 0.45' OF EXISTING ASPHALT CONCRETE AND BASE
  - 17 CONSTRUCT 0.20" HMA TYPE "A" PG 64-10 3/4" MIX OVER 0.25" HMA TYPE "A" PG 64-10 1" MIX
  - 18 REMOVE AND RECONSTRUCT CURB RAMP PER COUNTY OF RIVERSIDE STD No. 403, CASE A
  - 19 RELOCATE/RESET EXISTING MAILBOX PER PLAN
  - 20 CONSTRUCT ASPHALT CONCRETE DRIVEWAY PER COUNTY OF RIVERSIDE STD No. 206 (ON NATIVE AND MODIFIED FOR MOUNTABLE DIKE) [SEE DETAIL ON C-1 FOR SMALE CONDITION]
  - 21 PLACE SAFETY EDGE PER "SAFETY EDGE" DETAIL ON SHEET C-1
  - 22 CONSTRUCT 10' AC DIKE TO AC MOUNTABLE DIKE TRANSITION PER "AC DIKE TO AC MOUNTABLE DIKE TRANSITION DETAIL" ON SHEET C-1
  - 23 REMOVE AND RECONSTRUCT ASPHALT CONCRETE DRIVEWAY PER COUNTY OF RIVERSIDE STD No. 206, MODIFIED PER "MOUNTABLE DIKE DRIVEWAY DETAIL" ON SHEET C-1
  - 24 REMOVE AND RECONSTRUCT CONCRETE DRIVEWAY PER COUNTY OF RIVERSIDE STD No. 206, MODIFIED PER "MOUNTABLE DIKE DRIVEWAY DETAIL" ON SHEET C-1
  - 25 REMOVE AND RECONSTRUCT ASPHALT CONCRETE DRIVEWAY PER COUNTY OF RIVERSIDE STD No. 206 (MODIFIED FOR MOUNTABLE DIKE)
  - 26 CONSTRUCT DIRT SWALE PER DETAIL ON C-1

- SPECIAL NOTES:**
1. ALL EXISTING UTILITIES, UTILITY APPURTENANCES, OR OTHER ITEMS THAT ARE WITHIN GRADING/PAVING PLANE OR BEHIND C/G, SIDEWALK, AND DIKE ARE TO BE PROTECTED-IN-PLACE UNLESS OTHERWISE SPECIFIED ON PLANS.
  2. CONTRACTOR TO CLEAR AND CLEAN OUT DRAINAGE DITCHES, STORM DRAIN INLETS, CULVERTS, AND PIPES AS DIRECTED BY THE ENGINEER.

THE PRIVATE ENGINEER SIGNING THESE PLANS IS RESPONSIBLE FOR ASSURING THE ACCURACY AND ACCEPTABILITY OF THE DESIGN HEREON. IN THE EVENT OF DESCAPANCIES ARISING AFTER COUNTY APPROVAL OR DURING CONSTRUCTION, THE PRIVATE ENGINEER SHALL BE RESPONSIBLE FOR DETERMINING AN ACCEPTABLE SOLUTION AND REVISING THE PLANS FOR APPROVAL BY THE COUNTY.

<p>HDR ENGINEERING, INC.          PREPARED UNDER THE SUPERVISION OF:            CHARLES CHRISTOPOLIS          SENIOR HIGHWAY PROJECT MANAGER</p>	LAYOUT	SHEET No.
	<p><b>JOHNSTON AVENUE</b>          RESURFACING          23+59 TO 37+50</p>	<p><b>L-1</b>          SHEET 4 OF 17</p>

DATE PLOTTED => DATE  
 TIME PLOTTED => TIME  
 USERNAME => #USER  
 DON FILE => #REQUEST  
 WO B0-0612  
 COUNTY FILE No. **973-A**

ISSUED BY ADDENDUM NO. 1, ATTACHMENT "B"

BORDER LAST REVISED 09/20/17

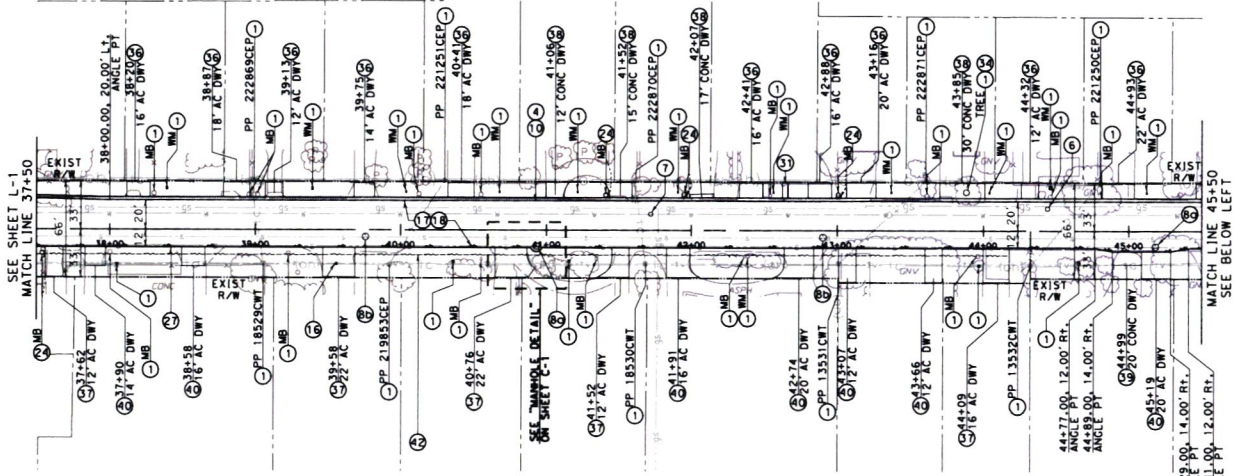

**JOHNSTON AVE**

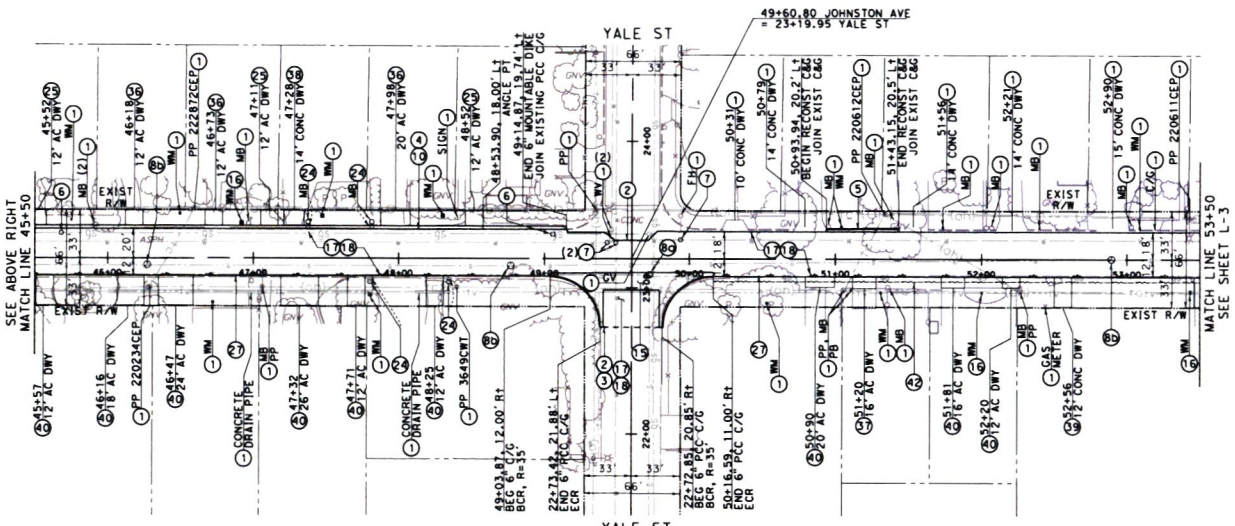

**JOHNSTON AVE**

- CONSTRUCTION NOTES:**
- 1 PROTECT
  - 2 MATCH EXISTING
  - 3 SAWCUT
  - 4 REMOVE EXISTING AC BERM AND/OR DIKE
  - 5 REMOVE AND RECONSTRUCT CURB AND GUTTER PER COUNTY OF RIVERSIDE STD NO. 200, TYPE A-6
  - 6 ADJUST GAS VALVE TO GRADE BY CONTRACTOR
  - 7 ADJUST WATER VALVE TO GRADE BY CONTRACTOR PER LHMMD STANDARDS
  - 8 ADJUST SEWER MANHOLE TO GRADE BY EMD
  - 9 ADJUST SEWER MANHOLE TO GRADE BY CONTRACTOR PER LHMMD STANDARDS
  - 10 CONSTRUCT 6" ASPHALT CONCRETE MOUNTABLE DIKE PER CALTRANS STD NO. A87B, TYPE D
  - 11 REMOVE AND RECONSTRUCT CROSS GUTTER AND SPANDREL PER COUNTY OF RIVERSIDE STD NO. 209
  - 12 ADJUST WATER METER TO GRADE PER LHMMD STANDARDS
  - 13 REMOVE 0.45' OF EXISTING ASPHALT CONCRETE AND BASE
  - 14 CONSTRUCT 0.20' HMA TYPE "A" PG 64-10 3/4" MIX OVER 0.25' HMA TYPE "A" PG 64-10 1" MIX
  - 15 RELOCATE/RESET EXISTING MAILBOX PER PLAN
  - 16 CONSTRUCT ASPHALT CONCRETE DRIVEWAY PER COUNTY OF RIVERSIDE STD NO. 206 (ON NATIVE AND MODIFIED FOR MOUNTABLE DIKE)
  - 17 PLACE SAFETY EDGE PER "SAFETY EDGE" DETAIL ON SHEET C-1
  - 18 REMOVE AND RECONSTRUCT 4" WIDE CONCRETE WALKWAY (4" THICK)
  - 19 RE-ESTABLISH TREE WELL IN DRIVEWAY
  - 20 REMOVE AND RECONSTRUCT ASPHALT CONCRETE DRIVEWAY PER COUNTY OF RIVERSIDE STD NO. 206 (MODIFIED FOR MOUNTABLE DIKE)
  - 21 REMOVE AND RECONSTRUCT ASPHALT CONCRETE DRIVEWAY (3.5" THICK ON NATIVE) (SEE DETAIL ON C-1 FOR SWALE CONDITION)
  - 22 REMOVE AND RECONSTRUCT CONCRETE DRIVEWAY PER COUNTY OF RIVERSIDE STD NO. 206 (MODIFIED FOR MOUNTABLE DIKE)
  - 23 REMOVE AND RECONSTRUCT CONCRETE DRIVEWAY (6" THICK ON NATIVE) [SEE DETAIL ON C-1 FOR SWALE CONDITION]
  - 24 CONSTRUCT ASPHALT CONCRETE DRIVEWAY (3.5" ON NATIVE) [SEE DETAIL ON C-1 FOR SWALE CONDITION]
  - 25 CONSTRUCT DIRT SWALE PER DETAIL ON C-1

- SPECIAL NOTES:**
1. ALL EXISTING UTILITIES, UTILITY APPURTENANCES, OR OTHER ITEMS THAT ARE WITHIN GRADING/PAVING PLANE OR BEHIND C/G, SIDEWALK, AND DIKE ARE TO BE PROTECTED-IN-PLACE UNLESS OTHERWISE SPECIFIED ON PLANS.
  2. CONTRACTOR TO CLEAR AND CLEAN OUT DRAINAGE DITCHES, STORM DRAIN INLETS, CULVERTS, AND PIPES AS DIRECTED BY THE ENGINEER.

THE PRIVATE ENGINEER SIGNING THESE PLANS IS RESPONSIBLE FOR ASSURING THE ACCURACY AND ACCEPTABILITY OF THE DESIGN HEREON. IN THE EVENT OF DISCREPANCIES ARISING AFTER COUNTY APPROVAL OR DURING CONSTRUCTION THE PRIVATE ENGINEER SHALL BE RESPONSIBLE FOR DETERMINING AN ACCEPTABLE SOLUTION AND REVISING THE PLANS FOR APPROVAL BY THE COUNTY.

BORDER LAST REVISED 09/2017

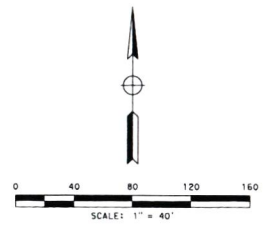

<p><b>HDR ENGINEERING, INC.</b> PREPARED UNDER THE SUPERVISION OF: <i>Charles Christopolis</i> 6/16/2023 CHARLES CHRISTOPLIS SENIOR HIGHWAY PROJECT MANAGER</p>	<p><b>LAYOUT</b></p> <p><b>JOHNSTON AVENUE</b> RESURFACING</p> <p>37+50 TO 53+50</p>	<p><b>SHEET No.</b></p> <p><b>L-2</b></p> <p>SHEET 5 OF 17</p>
	<p>USERNAME =&gt; BUSER DGN FILE =&gt; BREQUEST</p>	<p>WO B0-0612</p>

ISSUED BY ADDENDUM NO. 1, ATTACHMENT "B"

DATE PLOTTED => DATE TIME PLOTTED => 8/16/2023 10:00:00 AM

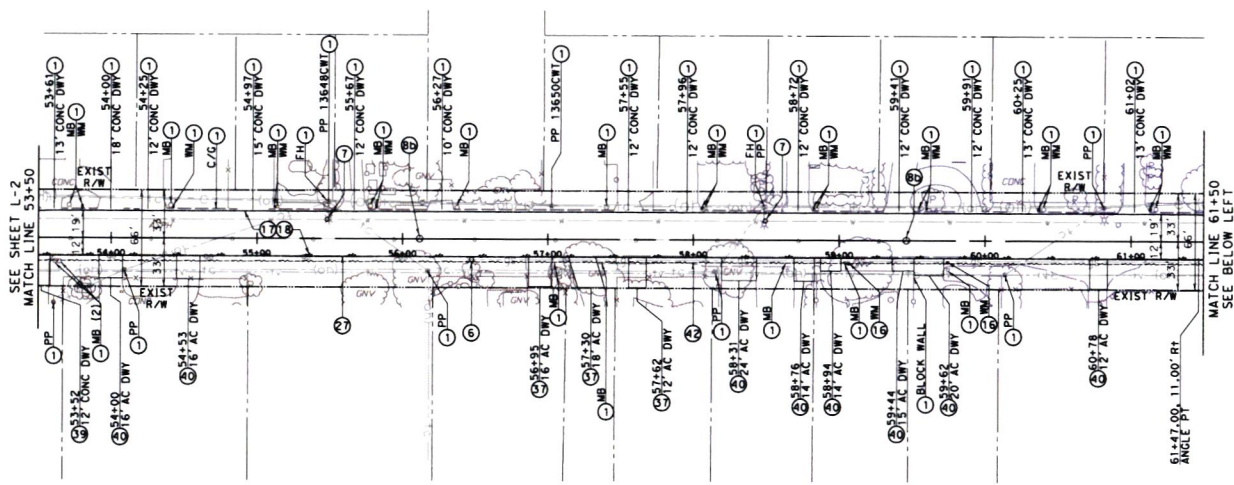

**JOHNSTON AVE**

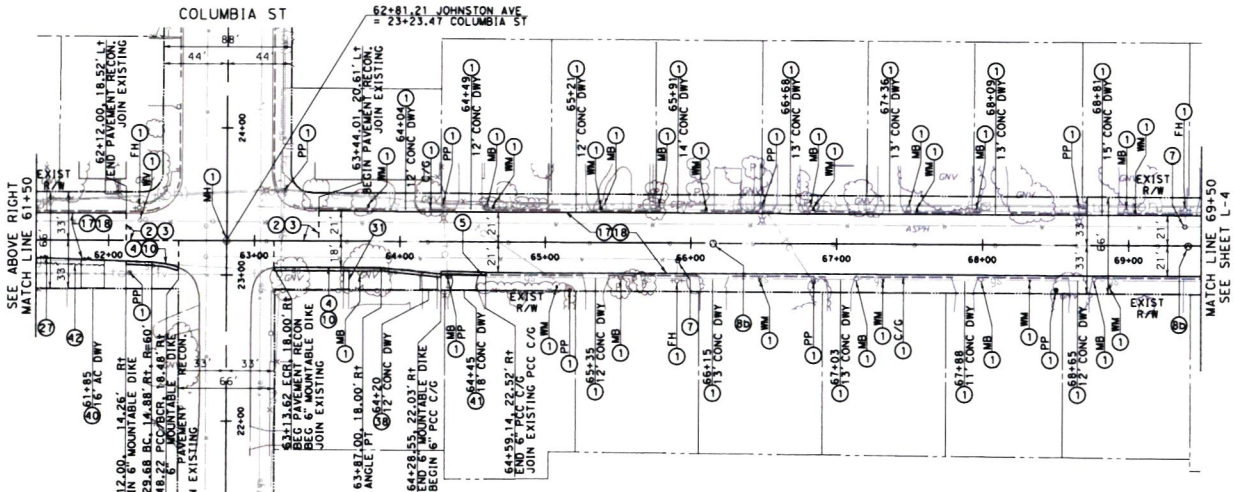

**JOHNSTON AVE**

**SPECIAL NOTES:**

1. ALL EXISTING UTILITIES, UTILITY APPURTENANCES, OR OTHER ITEMS THAT ARE WITHIN GRADING/PAVING PLANE OR BEHIND C/G, SIDEWALK, AND DIKE ARE TO BE PROTECTED-IN-PLACE UNLESS OTHERWISE SPECIFIED ON PLANS.

2. CONTRACTOR TO CLEAR AND CLEAN OUT DRAINAGE DITCHES, STORM DRAIN INLETS, CULVERTS, AND PIPES AS DIRECTED BY THE ENGINEER.

THE PRIVATE ENGINEER SIGNING THESE PLANS IS RESPONSIBLE FOR ASSURING THE ACCURACY AND ACCEPTABILITY OF THE DESIGN HEREOF. IN THE EVENT OF DISCREPANCIES ARISING AFTER COUNTY APPROVAL OR DURING CONSTRUCTION, THE PRIVATE ENGINEER SHALL BE RESPONSIBLE FOR DETERMINING AN ACCEPTABLE SOLUTION AND REVISING THE PLANS FOR APPROVAL BY THE COUNTY.

BORDER LAST REVISED 09/2017

**CONSTRUCTION NOTES:**

- 1 PROTECT
- 2 MATCH EXISTING
- 3 SAWCUT
- 4 REMOVE EXISTING AC BERM AND/OR DIKE
- 5 REMOVE AND RECONSTRUCT CURB AND GUTTER PER COUNTY OF RIVERSIDE STD NO. 200, TYPE A-6
- 6 ADJUST GAS VALVE TO GRADE BY CONTRACTOR
- 7 ADJUST WATER VALVE TO GRADE BY CONTRACTOR PER LHMWD STANDARDS
- 8 ADJUST SEWER MANHOLE TO GRADE BY CONTRACTOR PER LHMWD STANDARDS
- 9 CONSTRUCT 6" ASPHALT CONCRETE MOUNTABLE DIKE PER CALTRANS STD NO. AB7B, TYPE D
- 10 ADJUST WATER METER TO GRADE PER LHMWD STANDARDS
- 11 REMOVE 0.45' OF EXISTING ASPHALT CONCRETE AND BASE
- 12 CONSTRUCT 0.20' HMA TYPE "A" PG 64-10 3/4" MIX OVER 0.25' HMA TYPE "A" PG 64-10 1" MIX
- 13 PLACE SAFETY EDGE PER "SAFETY EDGE" DETAIL ON SHEET C-1
- 14 REMOVE AND RECONSTRUCT 4' WIDE CONCRETE WALKWAY (4" THICK)
- 15 REMOVE AND RECONSTRUCT ASPHALT CONCRETE DRIVEWAY (3.5" THICK ON NATIVE) [SEE DETAIL ON C-1 FOR SWALE CONDITION]
- 16 REMOVE AND RECONSTRUCT CONCRETE DRIVEWAY PER COUNTY OF RIVERSIDE STD NO. 206 (MODIFIED FOR MOUNTABLE DIKE)
- 17 REMOVE AND RECONSTRUCT CONCRETE DRIVEWAY (6" THICK ON NATIVE) [SEE DETAIL ON C-1 FOR SWALE CONDITION]
- 18 CONSTRUCT ASPHALT CONCRETE DRIVEWAY (3.5" ON NATIVE) [SEE DETAIL ON C-1 FOR SWALE CONDITION]
- 19 REMOVE AND RECONSTRUCT DRIVEWAY PER COUNTY OF RIVERSIDE STD NO. 206 (MODIFIED FOR CURB AND GUTTER)
- 20 CONSTRUCT DIRT SWALE PER DETAIL ON C-1

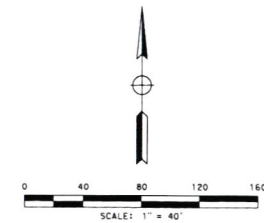

	<p>HDR ENGINEERING, INC.</p> <p>PREPARED UNDER THE SUPERVISION OF:</p> <p><i>Charles Christopoulos</i> 6/16/2023 DATE</p> <p>CHARLES CHRISTOPOULOS SENIOR HIGHWAY PROJECT MANAGER HDR</p>	<p>LAYOUT</p> <p><b>JOHNSTON AVENUE</b></p> <p>RESURFACING</p> <p>63+50 TO 69+50</p>	<p>SHEET No.</p> <p><b>L-3</b></p> <p>SHEET 6 OF 17</p>
	<p>USERNAME =&gt; #USER DON FILE =&gt; #REQUEST</p>	<p>WO B0-0612</p>	<p>COUNTY FILE No. <b>973-A</b></p>

ISSUED BY ADDENDUM No. 1, ATTACHMENT "B"

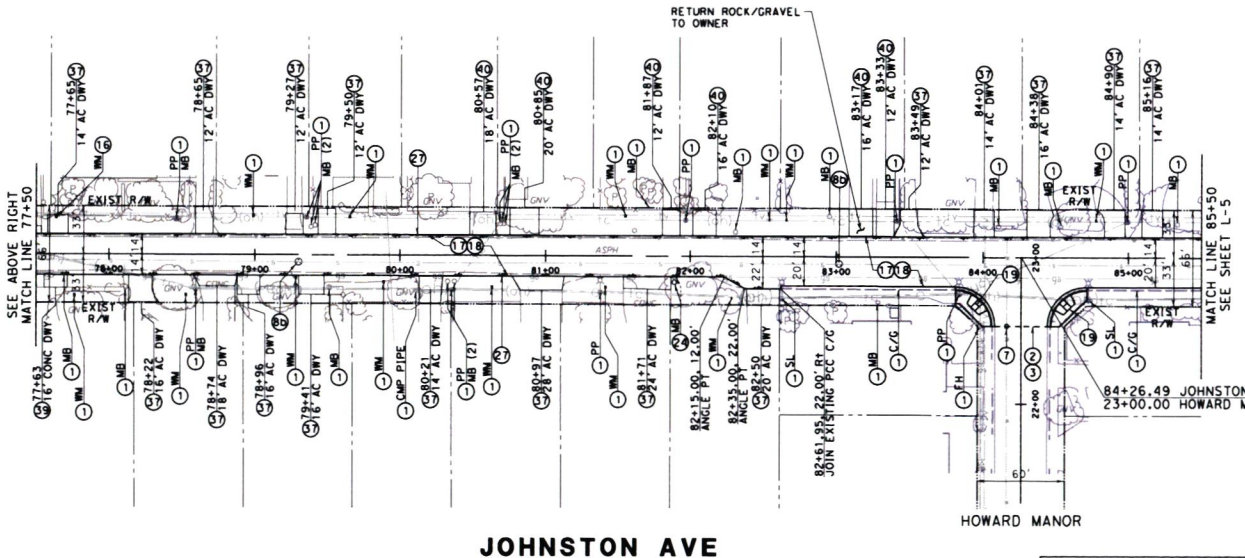
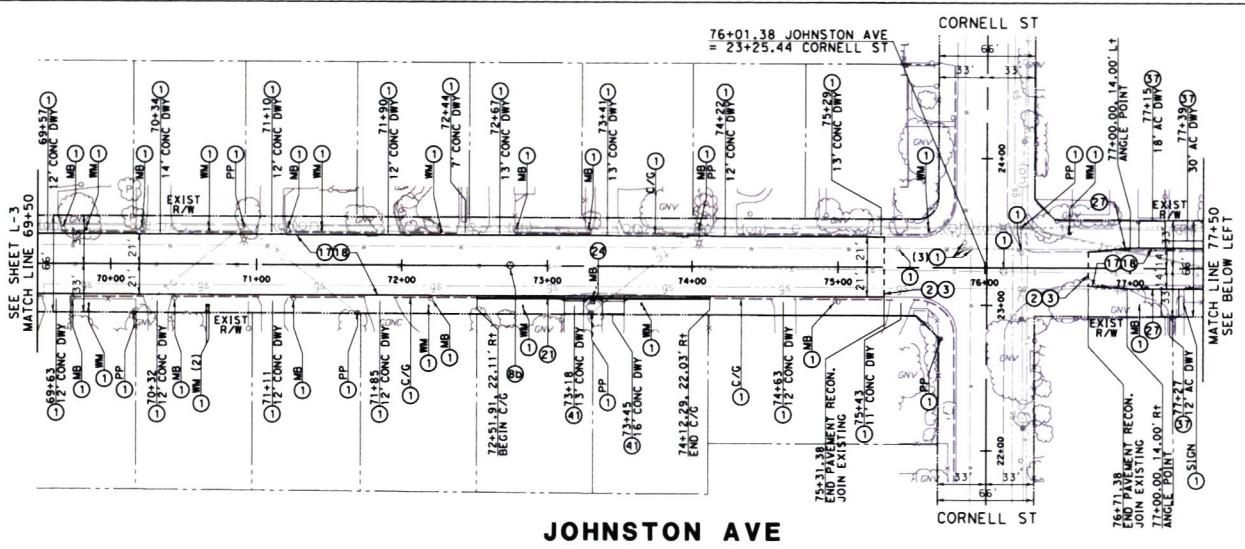

- CONSTRUCTION NOTES:**
- 1 PROTECT
  - 2 MATCH EXISTING
  - 3 SAWCUT
  - 4 ADJUST GAS VALVE TO GRADE BY CONTRACTOR
  - 5 ADJUST WATER VALVE TO GRADE BY CONTRACTOR PER LHMWD STANDARDS
  - 6 ADJUST SEWER MANHOLE TO GRADE BY CONTRACTOR PER LHMWD STANDARDS
  - 7 ADJUST WATER METER TO GRADE PER LHMWD STANDARDS
  - 8 REMOVE 0.45' OF EXISTING ASPHALT CONCRETE AND BASE
  - 9 CONSTRUCT 0.20" HMA TYPE "A" PG 64-10 3/4" MIX OVER 0.25" HMA TYPE "A" PG 64-10 1" MIX
  - 10 REMOVE AND RECONSTRUCT CURB RAMP PER COUNTY OF RIVERSIDE STD NO. 403, CASE A
  - 11 CONSTRUCT CURB AND GUTTER PER COUNTY OF RIVERSIDE STD NO. 200, TYPE A-6
  - 12 RELOCATE/RESET EXISTING MAILBOX PER PLAN
  - 13 PLACE SAFETY EDGE PER "SAFETY EDGE" DETAIL ON SHEET C-1
  - 14 REMOVE AND RECONSTRUCT ASPHALT CONCRETE DRIVEWAY (3.5" THICK ON NATIVE)
  - 15 REMOVE AND RECONSTRUCT CONCRETE DRIVEWAY (6" THICK ON NATIVE)
  - 16 CONSTRUCT ASPHALT CONCRETE DRIVEWAY (3.5" ON NATIVE)
  - 17 REMOVE AND RECONSTRUCT DRIVEWAY PER COUNTY OF RIVERSIDE STD NO. 206 (MODIFIED FOR CURB AND GUTTER)

- SPECIAL NOTES:**
1. ALL EXISTING UTILITIES, UTILITY APPURTENANCES, OR OTHER ITEMS THAT ARE WITHIN GRADING/PAVING PLANE OR BEHIND C/G, SIDEWALK, AND DIKE ARE TO BE PROTECTED-IN-PLACE UNLESS OTHERWISE SPECIFIED ON PLANS.
  2. CONTRACTOR TO CLEAR AND CLEAN OUT DRAINAGE DITCHES, STORM DRAIN INLETS, CULVERTS, AND PIPES AS DIRECTED BY THE ENGINEER.

THE PRIVATE ENGINEER SIGNING THESE PLANS IS RESPONSIBLE FOR ASSURING THE ACCURACY AND ACCEPTABILITY OF THE DESIGN HEREON. IN THE EVENT OF DESCREANCIES ARISING AFTER COUNTY APPROVAL OR DURING CONSTRUCTION, THE PRIVATE ENGINEER SHALL BE RESPONSIBLE FOR DETERMINING AN ACCEPTABLE SOLUTION AND REVISING THE PLANS FOR APPROVAL BY THE COUNTY.

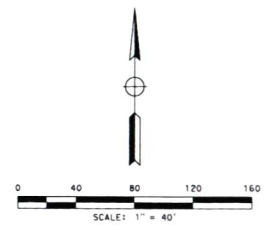

BORDER LAST REVISED 09/2017

	<p>HDR ENGINEERING, INC. PREPARED UNDER THE SUPERVISION OF:</p>	<p>LAYOUT</p>	<p>SHEET No.</p>
	<p>CHARLES CHRISTOPHER 6/16/2023 DATE SENIOR HIGHWAY PROJECT MANAGER</p>	<p><b>JOHNSTON AVENUE</b> RESURFACING 69+50 TO 85+50</p>	<p><b>L-4</b> SHEET 7 OF 17</p>

USERNAME => JUSER  
DCN FILE => REQUEST  
WO 80-0612  
COUNTY FILE No. **973-A**

ISSUED BY ADDENDUM No. 1, ATTACHMENT "B"

**Riverside County Transportation Department  
Summary of Bids**

**PROJECT:** Johnston Avenue Resurfacing  
San Jacinto Street to 630-Foot East of Stanford Street  
Community of East Hemet

Advertised: June 13, 2023 (Agenda Item: 3.28)

Addenda: 1 (6/28/23)

Bids Open: 2 pm Date: Wednesday, July 5, 2023

Project No. B0-0612

Company Name	BASE BID SCHEDULE Johnston Avenue Resurfacing	ALTERNATIVE BID SCHEDULE 1 EMWD Manhole Adjustments	Project Total
COUNTY'S ESTIMATE	2,918,650.00	12,500.00	\$2,931,150.00
<b>1 Onyx Paving Company, Inc.</b>	2,932,000.00	6,000.00	<b>\$2,938,000.00</b>
<b>2 All American Asphalt</b>	3,249,889.50	10,000.00	<b>\$3,259,889.50</b>
<b>3 Hardy &amp; Harper, Inc.</b>	3,321,051.00	17,500.00	<b>\$3,338,551.00</b>
<b>4 Hillcrest Contracting, LLC</b>	3,724,457.50	5,800.00	<b>\$3,730,257.50</b>
<i>Average Bid Prices</i>	<b>\$3,306,849.50</b>	<b>\$9,825.00</b>	<b>\$3,316,674.50</b>

**Riverside County Transportation Department  
Summary of Bids**

**PROJECT: Johnston Avenue Resurfacing  
San Jacinto Street to 630-Foot East of Stanford Street  
Community of East Hemet  
Project No. B0-0612**

Advertised: June13, 2023 (Agenda Item: 3.28)

Addenda: 1 (6/28/23)

Bids Open: 2 pm Date: Wednesday, July 5, 2023

BASE BID SCHEDULE - Johnston Avenue Resurfacing					COUNTY'S ESTIMATE		1 Onyx Paving Company, Inc. Anaheim, CA 92806	
ITEM NO.	ITEM CODE	CONTRACT ITEM	UNITS	QUANTITY	UNIT PRICE	ENG ESTIMATE	BID UNIT PRICE	BID ESTIMATE
1	100100	DEVELOP WATER SUPPLY	LS	1	10,000.00	10,000.00	11,602.00	11,602.00
2	120100	TRAFFIC CONTROL SYSTEM	LS	1	200,000.00	200,000.00	222,000.00	222,000.00
3	130200	PREPARE WATER POLLUTION CONTROL PROGRAM	LS	1	10,000.00	10,000.00	11,000.00	11,000.00
4	170103	CLEARING AND GRUBBING	LS	1	75,000.00	75,000.00	333,000.00	333,000.00
5	066100	DUST ABATEMENT	LS	1	15,000.00	15,000.00	11,000.00	11,000.00
6	190101(F)	ROADWAY EXCAVATION	CY	5,300	55.00	291,500.00	55.00	291,500.00
7	013903	PLACE ASPHALT CONCRETE DIKE (CRS 212) (6")	LF	95	10.00	950.00	11.00	1,045.00
8	013904	PLACE ASPHALT CONCRETE DIKE (CRS 212) (8")	LF	95	10.00	950.00	11.00	1,045.00
9	394075	PLACE HOT MIX ASPHALT DIKE (TYPE D) [PER CALTRANS STD A87B]	LF	1,900	10.00	19,000.00	11.00	20,900.00
10	394075	PLACE HOT MIX ASPHALT DIKE (TYPE D) [PER CALTRANS STD A87B, MODIFIED TO 8" HEIGHT]	LF	550	10.00	5,500.00	11.00	6,050.00
11	394076	PLACE HOT MIX ASPHALT DIKE (TYPE E) (PER CALTRANS STD. A87B)	LF	30	75.00	2,250.00	11.00	330.00
12	390132	HOT MIX ASPHALT (TYPE A)	TON	11,500	120.00	1,380,000.00	111.00	1,276,500.00
13	013905	ASPHALT CONCRETE (DRIVEWAY APPROACH WITH ASPHALT CONCRETE DIKE) (CRS 206)	SQFT	180	10.00	1,800.00	10.00	1,800.00
14	013905	ASPHALT CONCRETE (DRIVEWAY APPROACH WITH ASPHALT CONCRETE DIKE) (CRS 206) [MODIFIED FOR ASPHALT CONCRETE DRIVEWAY	SQFT	6,600	10.00	66,000.00	6.00	39,600.00
15	013908	[3.5-INCH ON NATIVE]	SQFT	18,000	10.00	180,000.00	5.00	90,000.00
16	710220	ADJUST UTILITY COVER TO GRADE [WATER METER, LHMWD]	EA	15	1,000.00	15,000.00	2,000.00	30,000.00
17	710200	ADJUST MANHOLE [LHMWD]	EA	24	2,500.00	60,000.00	1,500.00	36,000.00
18	710192	ADJUST SEWER CLEANOUT TO GRADE [LHMWD]	EA	2	500.00	1,000.00	1,500.00	3,000.00
19	731516	MINOR CONCRETE (DRIVEWAY) [CRS 213]	SQFT	160	20.00	3,200.00	20.00	3,200.00
20	731516	MINOR CONCRETE (DRIVEWAY) [MODIFIED FOR MOUNTABLE DIKE]	SQFT	1,400	20.00	28,000.00	20.00	28,000.00
21	731516	MINOR CONCRETE (DRIVEWAY) [6-INCH ON NATIVE]	SQFT	950	20.00	19,000.00	20.00	19,000.00



**Riverside County Transportation Department  
Summary of Bids**

**PROJECT: Johnston Avenue Resurfacing  
San Jacinto Street to 630-Foot East of Stanford Street  
Community of East Hemet  
Project No. B0-0612**

Advertised: June13, 2023 (Agenda Item: 3.28)

Addenda: 1 (6/28/23)

Bids Open: 2 pm Date: Wednesday, July 5, 2023

BASE BID SCHEDULE - Johnston Avenue Resurfacing (Continued)					COUNTY'S ESTIMATE		1 Onyx Paving Company, Inc. Anaheim, CA 92806	
ITEM NO.	ITEM CODE	CONTRACT ITEM	UNITS	QUANTITY	UNIT PRICE	ENG ESTIMATE	BID UNIT PRICE	BID ESTIMATE
22	017301	MINOR CONCRETE (DRIVEWAY APPROACH WITH ASPHALT CONCRETE DIKE) (CRS 206) [MODIFIED FOR CURB AND GUTTER]	SQFT	550	20.00	11,000.00	20.00	11,000.00
23	017304	MINOR CONCRETE (CURB AND GUTTER) (CRS 200)	LF	420	80.00	33,600.00	69.00	28,980.00
24	017315	MINOR CONCRETE (CURB RAMP) (CRS 403 - CASE A)	EA	4	10,000.00	40,000.00	8,400.00	33,600.00
25	017316	MINOR CONCRETE (CURB RAMP) (CRS 403 - CASE B) [MODIFIED PER PLAN]	EA	2	10,000.00	20,000.00	8,400.00	16,800.00
26	017317	MINOR CONCRETE (CROSS-GUTTER AND SPANDREL) (CRS 209)	SQFT	4,100	40.00	164,000.00	27.00	110,700.00
27	510502	MINOR CONCRETE (MINOR STRUCTURE) [CRS 308, MODIFIED FOR REVERSE FLOW INLET, WIDTH = 4']	EA	1	12,500.00	12,500.00	27,000.00	27,000.00
28	011503	UNDER SIDEWALK DRAIN CAST IN PLACE (CRS 309)	EA	1	6,500.00	6,500.00	16,880.00	16,880.00
29	731507	MINOR CONCRETE (GUTTER DEPRESSION)	EA	1	1,500.00	1,500.00	9,000.00	9,000.00
30	731521	MINOR CONCRETE (SIDEWALK) [AND 4' WALKWAYS]	SQFT	670	15.00	10,050.00	13.00	8,710.00
31	782110	RESET MAILBOX [OR RELOCATE MAILBOX]	EA	15	750.00	11,250.00	400.00	6,000.00
32	810230(F)	PAVEMENT MARKER (RETROREFLECTIVE)	EA	310	5.00	1,550.00	11.00	3,410.00
33	820250	REMOVE ROADSIDE SIGN [AND SALVAGE]	EA	22	100.00	2,200.00	111.00	2,442.00
34	820840	ROADSIDE SIGN - ONE POST	EA	22	350.00	7,700.00	373.00	8,206.00
35	840656(F)	PAINT TRAFFIC STRIPE (2-COAT)	LF	14,500	0.50	7,250.00	0.55	7,975.00
36	840519	THERMOPLASTIC CROSSWALK AND PAVEMENT MARKING	SQFT	675	8.00	5,400.00	7.00	4,725.00
37	010602	MISCELLANEOUS WORK (AS DIRECTED)	FA	1	200,000.00	200,000.00	200,000.00	200,000.00
<b>BASE BID SCH - SUB-TOTAL ITEMS 1 - 37</b>						<b>2,918,650.00</b>		<b>2,932,000.00</b>

**Riverside County Transportation Department  
Summary of Bids**

**PROJECT: Johnston Avenue Resurfacing  
San Jacinto Street to 630-Foot East of Stanford Street  
Community of East Hemet  
Project No. B0-0612**

Advertised: June 13, 2023 (Agenda Item: 3.28)

Addenda: 1 (6/28/23)

Bids Open: 2 pm Date: Wednesday, July 5, 2023

ALTERNATIVE BID SCHEDULE 1 - EMWD Manhole Adjustments					COUNTY'S ESTIMATE		1 Onyx Paving Company, Inc. Anaheim, CA 92806	
ITEM NO.	ITEM CODE	CONTRACT ITEM	UNITS	QUANTITY	UNIT PRICE	ENG ESTIMATE	BID UNIT PRICE	BID ESTIMATE
38	710200	ADJUST MANHOLE [EMWD]	EA	5	2,500.00	12,500.00	1,200.00	6,000.00
		<b>ALT BID SCH 1 - SUB-TOTAL ITEM 38</b>				<b>12,500.00</b>		<b>6,000.00</b>

<b>PROJECT TOTAL ITEMS 1 - 38</b>					<b>2,931,150.00</b>		<b>2,938,000.00</b>	
---------------------------------------	--	--	--	--	---------------------	--	---------------------	--

**Riverside County Transportation Department  
Summary of Bids**

**PROJECT: Johnston Avenue Resurfacing  
San Jacinto Street to 630-Foot East of Stanford Street  
Community of East Hemet  
Project No. B0-0612**

Advertised: June 13, 2023 (Agenda Item: 3.28)

Addenda: 1 (6/28/23)

Bids Open: 2 pm Date: Wednesday, July 5, 2023

BASE BID SCHEDULE - Johnston Avenue Resurfacing					2 All American Asphalt Corona, CA 92878		3 Hardy & Harper, Inc. Lake Forest, CA 92630	
ITEM NO.	ITEM CODE	CONTRACT ITEM	UNITS	QUANTITY	BID UNIT PRICE	BID ESTIMATE	BID UNIT PRICE	BID ESTIMATE
1	100100	DEVELOP WATER SUPPLY	LS	1	10,000.00	10,000.00	5,350.00	5,350.00
2	120100	TRAFFIC CONTROL SYSTEM	LS	1	414,000.00	414,000.00	208,650.00	208,650.00
3	130200	PREPARE WATER POLLUTION CONTROL PROGRAM	LS	1	20,000.00	20,000.00	10,200.00	10,200.00
4	170103	CLEARING AND GRUBBING	LS	1	90,000.00	90,000.00	180,800.00	180,800.00
5	066100	DUST ABATEMENT	LS	1	10,000.00	10,000.00	8,100.00	8,100.00
6	190101(F)	ROADWAY EXCAVATION	CY	5,300	89.00	471,700.00	92.00	487,600.00
7	013903	PLACE ASPHALT CONCRETE DIKE (CRS 212) (6")	LF	95	8.00	760.00	10.00	950.00
8	013904	PLACE ASPHALT CONCRETE DIKE (CRS 212) (8")	LF	95	8.00	760.00	20.00	1,900.00
9	394075	PLACE HOT MIX ASPHALT DIKE (TYPE D) [PER CALTRANS STD. A87B]	LF	1,900	8.00	15,200.00	17.30	32,870.00
10	394075	PLACE HOT MIX ASPHALT DIKE (TYPE D) [PER CALTRANS STD A87B, MODIFIED TO 8" HEIGHT]	LF	550	8.00	4,400.00	28.00	15,400.00
11	394076	PLACE HOT MIX ASPHALT DIKE (TYPE E) (PER CALTRANS STD. A87B)	LF	30	8.00	240.00	46.00	1,380.00
12	390132	HOT MIX ASPHALT (TYPE A)	TON	11,500	111.00	1,276,500.00	116.00	1,334,000.00
13	013905	ASPHALT CONCRETE (DRIVEWAY APPROACH WITH ASPHALT CONCRETE DIKE) (CRS 206)	SQFT	180	12.00	2,160.00	8.40	1,512.00
14	013905	ASPHALT CONCRETE (DRIVEWAY APPROACH WITH ASPHALT CONCRETE DIKE) (CRS 206) [MODIFIED FOR ASPHALT CONCRETE DRIVEWAY	SQFT	6,600	12.00	79,200.00	8.35	55,110.00
15	013908	[3.5-INCH ON NATIVE]	SQFT	18,000	12.00	216,000.00	8.35	150,300.00
16	710220	ADJUST UTILITY COVER TO GRADE [WATER METER, LHMWD]	EA	15	1,850.00	27,750.00	1,350.00	20,250.00
17	710200	ADJUST MANHOLE [LHMWD]	EA	24	2,000.00	48,000.00	1,350.00	32,400.00
18	710192	ADJUST SEWER CLEANOUT TO GRADE [LHMWD]	EA	2	2,000.00	4,000.00	1,350.00	2,700.00
19	731516	MINOR CONCRETE (DRIVEWAY) [CRS 213]	SQFT	160	23.00	3,680.00	36.00	5,760.00
20	731516	MINOR CONCRETE (DRIVEWAY) [MODIFIED FOR MOUNTABLE DIKE]	SQFT	1,400	22.00	30,800.00	36.00	50,400.00
21	731516	MINOR CONCRETE (DRIVEWAY) [6-INCH ON NATIVE]	SQFT	950	22.00	20,900.00	36.00	34,200.00

**Riverside County Transportation Department  
Summary of Bids**

**PROJECT: Johnston Avenue Resurfacing  
San Jacinto Street to 630-Feet East of Stanford Street  
Community of East Hemet  
Project No. B0-0612**

Advertised: June13, 2023 (Agenda Item: 3.28)

Addenda: 1 (6/28/23)

Bids Open: 2 pm Date: Wednesday, July 5, 2023

BASE BID SCHEDULE - Johnston Avenue Resurfacing (Continued)					2 All American Asphalt Corona, CA 92878		3 Hardy & Harper, Inc. Lake Forest, CA 92630	
ITEM NO.	ITEM CODE	CONTRACT ITEM	UNITS	QUANTITY	BID UNIT PRICE	BID ESTIMATE	BID UNIT PRICE	BID ESTIMATE
22	017301	MINOR CONCRETE (DRIVEWAY APPROACH WITH ASPHALT CONCRETE DIKE) (CRS 206) [MODIFIED FOR CURB AND GUTTER]	SQFT	550	23.00	12,650.00	31.00	17,050.00
23	017304	MINOR CONCRETE (CURB AND GUTTER) (CRS 200)	LF	420	73.00	30,660.00	150.00	63,000.00
24	017315	MINOR CONCRETE (CURB RAMP) (CRS 403 - CASE A)	EA	4	12,000.00	48,000.00	16,700.00	66,800.00
25	017316	MINOR CONCRETE (CURB RAMP) (CRS 403 - CASE B) [MODIFIED PER PLAN]	EA	2	12,000.00	24,000.00	16,700.00	33,400.00
26	017317	MINOR CONCRETE (CROSS-GUTTER AND SPANDREL) (CRS 209)	SQFT	4,100	29.00	118,900.00	46.00	188,600.00
27	510502	MINOR CONCRETE (MINOR STRUCTURE) [CRS 308, MODIFIED FOR REVERSE FLOW INLET, WIDTH = 4']	EA	1	9,700.00	9,700.00	27,300.00	27,300.00
28	011503	UNDER SIDEWALK DRAIN CAST IN PLACE (CRS 309)	EA	1	12,000.00	12,000.00	23,600.00	23,600.00
29	731507	MINOR CONCRETE (GUTTER DEPRESSION)	EA	1	4,200.00	4,200.00	7,300.00	7,300.00
30	731521	MINOR CONCRETE (SIDEWALK) [AND 4' WALKWAYS]	SQFT	670	15.00	10,050.00	26.00	17,420.00
31	782110	RESET MAILBOX [OR RELOCATE MAILBOX]	EA	15	670.00	10,050.00	800.00	12,000.00
32	810230(F)	PAVEMENT MARKER (RETROREFLECTIVE)	EA	310	8.00	2,480.00	8.00	2,480.00
33	820250	REMOVE ROADSIDE SIGN [AND SALVAGE]	EA	22	81.00	1,782.00	81.00	1,782.00
34	820840	ROADSIDE SIGN - ONE POST	EA	22	325.00	7,150.00	321.00	7,062.00
35	840656(F)	PAINT TRAFFIC STRIPE (2-COAT)	LF	14,500	0.54	7,830.00	0.60	8,700.00
36	840519	THERMOPLASTIC CROSSWALK AND PAVEMENT MARKING	SQFT	675	6.50	4,387.50	7.00	4,725.00
37	010602	MISCELLANEOUS WORK (AS DIRECTED)	FA	1	200,000.00	200,000.00	200,000.00	200,000.00
<b>BASE BID SCH - SUB-TOTAL ITEMS 1 - 37</b>						<b>3,249,889.50</b>		<b>3,321,051.00</b>

**Riverside County Transportation Department  
Summary of Bids**

**PROJECT: Johnston Avenue Resurfacing  
San Jacinto Street to 630-Foot East of Stanford Street  
Community of East Hemet  
Project No. B0-0612**

Advertised: June 13, 2023 (Agenda Item: 3.28)

Addenda: 1 (6/28/23)

Bids Open: 2 pm Date: Wednesday, July 5, 2023

ALTERNATIVE BID SCHEDULE 1 - EMWD Manhole Adjustments					2 All American Asphalt Corona, CA 92878		3 Hardy & Harper, Inc. Lake Forest, CA 92630	
ITEM NO.	ITEM CODE	CONTRACT ITEM	UNITS	QUANTITY	BID UNIT PRICE	BID ESTIMATE	BID UNIT PRICE	BID ESTIMATE
38	710200	ADJUST MANHOLE [EMWD]	EA	5	2,000.00	10,000.00	3,500.00	17,500.00
		<b>ALT BID SCH 1 - SUB-TOTAL ITEM 38</b>				<b>10,000.00</b>		<b>17,500.00</b>

<b>PROJECT TOTAL ITEMS 1 - 38</b>					<b>3,259,889.50</b>		<b>3,338,551.00</b>	
---------------------------------------	--	--	--	--	---------------------	--	---------------------	--

**Riverside County Transportation Department**  
**Summary of Bids**

**PROJECT: Johnston Avenue Resurfacing**  
**San Jacinto Street to 630-Foot East of Stanford Street**  
**Community of East Hemet**  
**Project No. B0-0612**

Advertised: June13, 2023 (Agenda Item: 3.28)

Addenda: 1 (6/28/23)

Bids Open: 2 pm Date: Wednesday, July 5, 2023

BASE BID SCHEDULE - Johnston Avenue Resurfacing					4 Hillcrest Contracting, LLC Corona, CA 92879			
ITEM NO.	ITEM CODE	CONTRACT ITEM	UNITS	QUANTITY	BID UNIT PRICE	BID ESTIMATE		
1	100100	DEVELOP WATER SUPPLY	LS	1	168,000.00	168,000.00		
2	120100	TRAFFIC CONTROL SYSTEM	LS	1	197,000.00	197,000.00		
3	130200	PREPARE WATER POLLUTION CONTROL PROGRAM	LS	1	27,000.00	27,000.00		
4	170103	CLEARING AND GRUBBING	LS	1	212,000.00	212,000.00		
5	066100	DUST ABATEMENT	LS	1	27,600.00	27,600.00		
6	190101(F)	ROADWAY EXCAVATION	CY	5,300	83.00	439,900.00		
7	013903	PLACE ASPHALT CONCRETE DIKE (CRS 212) (6")	LF	95	8.80	836.00		
8	013904	PLACE ASPHALT CONCRETE DIKE (CRS 212) (8")	LF	95	17.30	1,643.50		
9	394075	PLACE HOT MIX ASPHALT DIKE (TYPE D) [PER CALTRANS STD A87B]	LF	1,900	15.00	28,500.00		
10	394075	PLACE HOT MIX ASPHALT DIKE (TYPE D) [PER CALTRANS STD A87B, MODIFIED TO 8" HEIGHT]	LF	550	20.70	11,385.00		
11	394076	PLACE HOT MIX ASPHALT DIKE (TYPE E) (PER CALTRANS STD. A87B)	LF	30	15.00	450.00		
12	390132	HOT MIX ASPHALT (TYPE A)	TON	11,500	140.00	1,610,000.00		
13	013905	ASPHALT CONCRETE (DRIVEWAY APPROACH WITH ASPHALT CONCRETE DIKE) (CRS 206)	SQFT	180	13.50	2,430.00		
14	013905	ASPHALT CONCRETE (DRIVEWAY APPROACH WITH ASPHALT CONCRETE DIKE) (CRS 206) [MODIFIED FOR ASPHALT CONCRETE DRIVEWAY	SQFT	6,600	12.00	79,200.00		
15	013908	[3.5-INCH ON NATIVE]	SQFT	18,000	11.90	214,200.00		
16	710220	ADJUST UTILITY COVER TO GRADE [WATER METER, LHMWD]	EA	15	2,100.00	31,500.00		
17	710200	ADJUST MANHOLE [LHMWD]	EA	24	1,160.00	27,840.00		
18	710192	ADJUST SEWER CLEANOUT TO GRADE [LHMWD]	EA	2	1,020.00	2,040.00		
19	731516	MINOR CONCRETE (DRIVEWAY) [CRS 213]	SQFT	160	22.70	3,632.00		
20	731516	MINOR CONCRETE (DRIVEWAY) [MODIFIED FOR MOUNTABLE DIKE]	SQFT	1,400	15.60	21,840.00		
21	731516	MINOR CONCRETE (DRIVEWAY) [6-INCH ON NATIVE]	SQFT	950	19.00	18,050.00		

**Riverside County Transportation Department  
Summary of Bids**

**PROJECT: Johnston Avenue Resurfacing  
San Jacinto Street to 630-Foot East of Stanford Street  
Community of East Hemet  
Project No. B0-0612**

Advertised: June 13, 2023 (Agenda Item: 3.28)

Addenda: 1 (6/28/23)

Bids Open: 2 pm Date: Wednesday, July 5, 2023

BASE BID SCHEDULE - Johnston Avenue Resurfacing (Continued)					4 Hillcrest Contracting, LLC Corona, CA 92879			
ITEM NO.	ITEM CODE	CONTRACT ITEM	UNITS	QUANTITY	BID UNIT PRICE	BID ESTIMATE		
22	017301	MINOR CONCRETE (DRIVEWAY APPROACH WITH ASPHALT CONCRETE DIKE) (CRS 206) [MODIFIED FOR CURB AND GUTTER]	SQFT	550	15.00	8,250.00		
23	017304	MINOR CONCRETE (CURB AND GUTTER) (CRS 200)	LF	420	102.00	42,840.00		
24	017315	MINOR CONCRETE (CURB RAMP) (CRS 403 - CASE A)	EA	4	8,300.00	33,200.00		
25	017316	MINOR CONCRETE (CURB RAMP) (CRS 403 - CASE B) [MODIFIED PER PLAN]	EA	2	9,600.00	19,200.00		
26	017317	MINOR CONCRETE (CROSS-GUTTER AND SPANDREL) (CRS 209)	SQFT	4,100	51.00	209,100.00		
27	510502	MINOR CONCRETE (MINOR STRUCTURE) [CRS 308, MODIFIED FOR REVERSE FLOW INLET, WIDTH = 4']	EA	1	21,000.00	21,000.00		
28	011503	UNDER SIDEWALK DRAIN CAST IN PLACE (CRS 309)	EA	1	15,200.00	15,200.00		
29	731507	MINOR CONCRETE (GUTTER DEPRESSION)	EA	1	2,640.00	2,640.00		
30	731521	MINOR CONCRETE (SIDEWALK) [AND 4' WALKWAYS]	SQFT	670	15.60	10,452.00		
31	782110	RESET MAILBOX [OR RELOCATE MAILBOX]	EA	15	620.00	9,300.00		
32	810230(F)	PAVEMENT MARKER (RETROREFLECTIVE)	EA	310	11.20	3,472.00		
33	820250	REMOVE ROADSIDE SIGN [AND SALVAGE]	EA	22	66.00	1,452.00		
34	820840	ROADSIDE SIGN - ONE POST	EA	22	390.00	8,580.00		
35	840656(F)	PAINT TRAFFIC STRIPE (2-COAT)	LF	14,500	0.55	7,975.00		
36	840519	THERMOPLASTIC CROSSWALK AND PAVEMENT MARKING	SQFT	675	10.00	6,750.00		
37	010602	MISCELLANEOUS WORK (AS DIRECTED)	FA	1	200,000.00	200,000.00		
		<b>BASE BID SCH - SUB-TOTAL ITEMS 1 - 37</b>				<b>3,724,457.50</b>		

**Riverside County Transportation Department  
Summary of Bids**

**PROJECT: Johnston Avenue Resurfacing  
San Jacinto Street to 630-Foot East of Stanford Street  
Community of East Hemet  
Project No. B0-0612**

Advertised: June 13, 2023 (Agenda Item: 3.28)

Addenda: 1 (6/28/23)

Bids Open: 2 pm Date: Wednesday, July 5, 2023

<b>ALTERNATIVE BID SCHEDULE 1 - EMWD Manhole Adjustments</b>					4 Hillcrest Contracting, LLC Corona, CA 92879			
ITEM NO.	ITEM CODE	CONTRACT ITEM	UNITS	QUANTITY	BID UNIT PRICE	BID ESTIMATE		
38	710200	ADJUST MANHOLE [EMWD]	EA	5	1,160.00	5,800.00		
		<b>ALT BID SCH 1 - SUB-TOTAL ITEM 38</b>				<b>5,800.00</b>		

<b>PROJECT TOTAL ITEMS 1 - 38</b>	<b>3,730,257.50</b>	
---------------------------------------	---------------------	--



COUNTY OF RIVERSIDE  
**TRANSPORTATION DEPARTMENT**

**JOHNSTON AVENUE RESURFACING**

SAN JACINTO STREET TO 630-FEET EAST OF STANFORD STREET

COMMUNITY OF EAST HEMET

PROJECT No. B0-0612

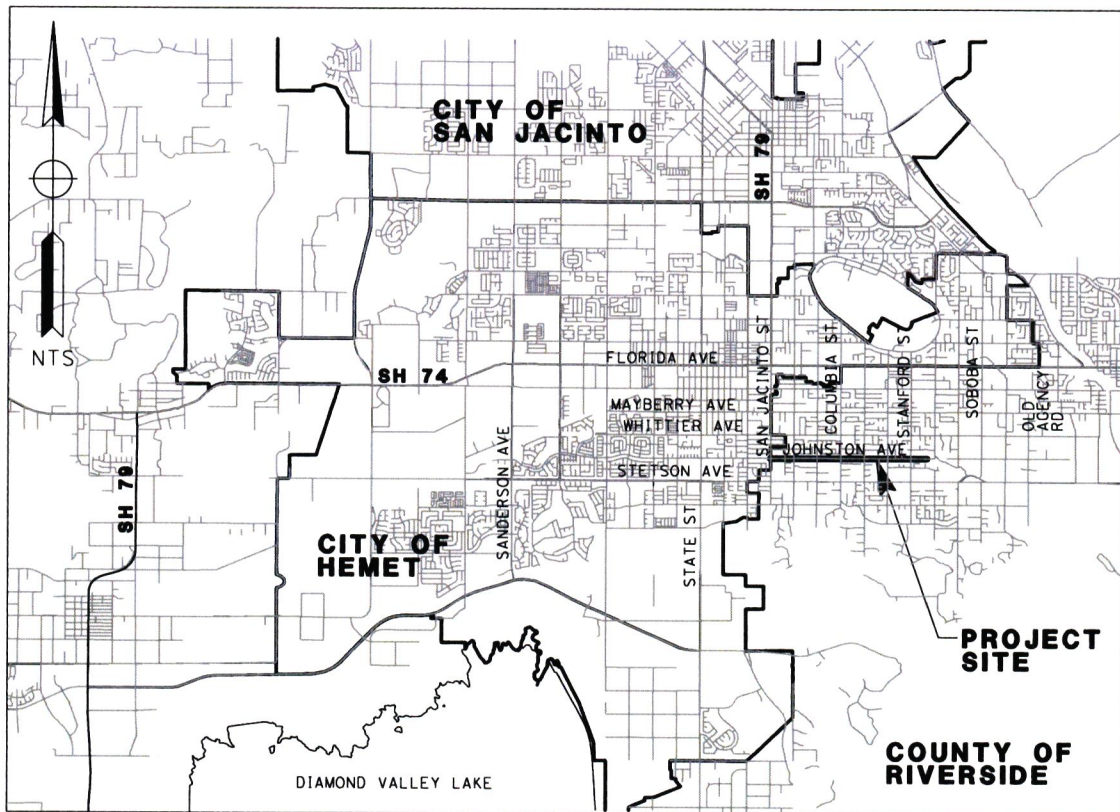
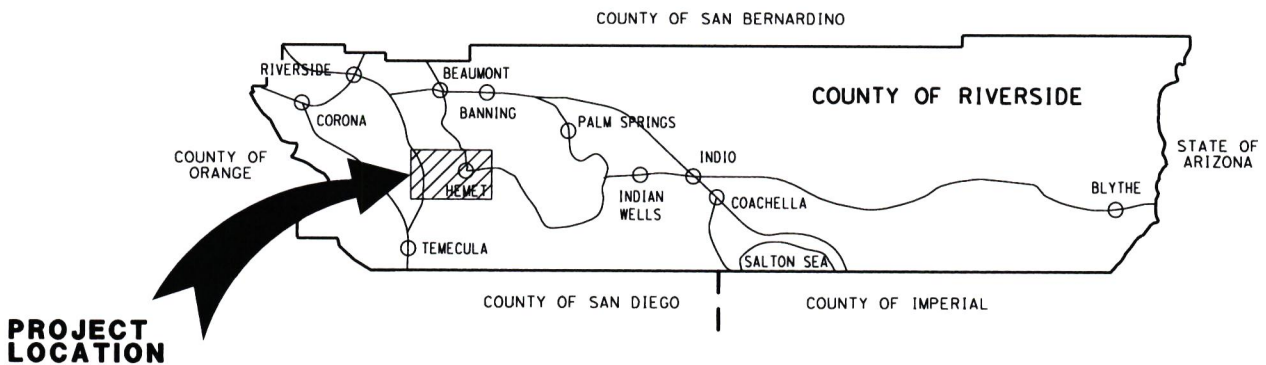

**VICINITY MAP**

# Attachment "A"

County of Riverside - Transportation Department

Expenses as of 7/28/2023

Project: **Johnston Avenue Resurfacing**

Project No.: **B0-0612**

## Project Costs and Budget

Activity	Incurred Costs	Projected Costs	Total Costs	Existing Budget	Proposed Budget
Preliminary Survey	54,736		55,000	100,000	55,000
Environmental				5,000	
Design	195,340	29,000	224,000	199,000	224,000
Right-of-way					
Utilities					
Construction		2,938,000			
Construction Contingency	10%	293,800	3,232,000	1,800,000	3,232,000
Construction Engineering & Inspection	15%	3,371	436,629	250,000	440,000
Construction Survey	5%	397	144,603	80,000	145,000
<b>Totals:</b>		<b>253,844</b>	<b>3,842,032</b>	<b>4,096,000</b>	<b>2,434,000</b>

## Project Funding

Code	Name	Existing Budget	Proposed Budget
223	Gas Tax/SB1	2,434,000	4,088,000
839	Eastern Muncipal Water District		8,000
<b>Totals</b>		<b>2,434,000</b>	<b>4,096,000</b>

## Comments