

**SUBMITTAL TO THE BOARD OF COMMISSIONERS
HOUSING AUTHORITY
COUNTY OF RIVERSIDE, STATE OF CALIFORNIA**



**ITEM: 10.1
(ID # 22827)**

MEETING DATE:
Tuesday, September 26, 2023

FROM : HOUSING AUTHORITY:

SUBJECT: HOUSING AUTHORITY: Approve the Form of the Section 8 Project-Based Voucher Program Agreement to Enter into a Housing Assistance Payments (AHAP) Contract for New Construction and Approve the Form of the Consent to Assignment of AHAP and HAP Contract as Security for Financing (PBV) for the Crossings at Palm Desert Project, Located in the City of Palm Desert, By and Between A0358 Monterey, L.P. and the Housing Authority of the County of Riverside; District 4. [\$0]

RECOMMENDED MOTION: That the Board of Commissioners:

1. Approve the form of the attached Section 8 Project-Based Voucher Program Agreement to Enter into a Housing Assistance Payments Contract for New Construction by and between A0358 Monterey, L.P., a California limited partnership, and the Housing Authority of the County of Riverside (AHAP Contract) for the Crossings at Palm Desert located in the City of Palm Desert;

Continued on Page 2

ACTION:Policy

Heidi Mays Hall, Director of Housing, Homelessness Prevention

9/9/2023

MINUTES OF THE BOARD OF COMMISSIONERS

On motion of Commissioner Gutierrez, seconded by Commissioner Washington and duly carried by unanimous vote, IT WAS ORDERED that the above matter is approved as recommended.

Ayes: Jeffries, Spiegel, Washington, Perez and Gutierrez
Nays: None
Absent: None
Date: September 26, 2023
xc: Housing Authority

Kimberly A. Rector
Clerk of the Board

By:
Deputy

**SUBMITTAL TO THE BOARD OF COMMISSIONERS HOUSING AUTHORITY
COUNTY OF RIVERSIDE, STATE OF CALIFORNIA**

RECOMMENDED MOTION: That the Board of Commissioners:

2. Approve the form of the Section 8 Project-Based Voucher Program Housing Assistance Payments Contract - New Construction or Rehabilitation Part 1 of HAP Contract (HAP Contract);
3. Approve the form of the Consent to Assignment of AHAP Contract and HAP Contract as Security for Financing (PBV) (Consent to Assignment); and
4. Authorize the Executive Director of the Housing Authority of the County of Riverside, or designee, to execute a form of the attached AHAP Contract, a form of the attached HAP Contract, and a form of the attached Consent to Assignment, each substantially conforming in form and substance to the attached AHAP Contract, HAP Contract, and Consent to Assignment, subject to approval as to form by County Counsel; and to take all necessary steps to implement the AHAP Contract, HAP Contract, and the Consent to Assignment including, but not limited to, signing subsequent necessary and relevant documents, subject to approval as to form by County Counsel.

FINANCIAL DATA	Current Fiscal Year:	Next Fiscal Year:	Total Cost:	Ongoing Cost
COST	\$ 0	\$ 0	\$ 0	\$ 0
NET COUNTY COST	\$ 0	\$ 0	\$ 0	\$ 0
SOURCE OF FUNDS: N/A			Budget Adjustment:	No
			For Fiscal Year:	23/24

C.E.O. RECOMMENDATION: Approve

BACKGROUND:

Summary

Urban Housing Communities LLC, a California limited liability company and affordable housing developer (Developer), was selected to receive a total of 87 Housing Choice Voucher Program (HCVP or Section 8) Project-Based Vouchers (PBVs). The PBVs were awarded in response to two competitive requests for proposals released on March 22, 2022 and October 18, 2022 by the Housing Authority of the County of Riverside (HACR) pursuant to Section 21.3 of the HACR's Administrative Plan for the HCVP and in compliance with 24 CFR 983.51 for Crossings at Palm Desert. The Project is proposed as a 176-unit affordable housing development, including permanent supportive housing units, on approximately 11.7 acres located at the northwest corner of Dick Kelly Drive and Gateway Avenue in the City of Palm Desert, identified as Assessor's Parcel Numbers 694-130-017, 694-130-018, 694-130-019 and 694-130-020 (Project). The Developer has formed a limited partnership known as A0358 Monterey, L.P., a California limited partnership (Partnership), for the purpose of owning, developing, and financing new construction of the Project.

**SUBMITTAL TO THE BOARD OF COMMISSIONERS HOUSING AUTHORITY
COUNTY OF RIVERSIDE, STATE OF CALIFORNIA**

The Project will consist of 44 one-bedroom units, 80 two-bedroom units, and 52 three-bedroom units within nine residential buildings. The PBVs will serve as a rental subsidy for 87 units (43 two-bedroom units and 44 three-bedroom units) reserved for households whose income do not exceed 30% of the area median income for clients on the HACR's HCVP waiting list. The two-bedroom units will be approximately 944 square feet and the three-bedroom units will be approximately 1,082 square feet. The Project will have a centralized community center that will feature a lounge, management office, computer room, central laundry room, a patio overlooking a play area with a tot lot, and swimming pool. The Project will be landscaped such that each residential building will have a small lawn area and open space for use by tenants to increase the livability of the Project. Supportive services will be determined by a thorough needs assessment of the residents; services will be provided by Ikaika Ohana and the Family YMCA of the Desert including caseworkers to coordinate and implement supportive services.

Pursuant to the National Environmental Policy Act (NEPA), on August 29, 2023 (Minute Order 3.33) the Board of Commissioners adopted the Environmental Assessment prepared by the County of Riverside Housing and Workforce Solutions (HWS) as the Responsible Entity which found that the proposed project would not have a significant effect on the environment.

Impact on Residents and Businesses

The rental assistance that the PBVs are providing the project will have a positive impact on the residents to stabilize housing and operation of the new construction housing complex in addition to providing affordable housing to the community.

SUPPLEMENTAL:

Additional Fiscal Information

No impact upon the County's General Fund. The Housing Authority's contribution to the project includes Housing Choice Voucher Program Project-Based Vouchers which are fully funded from the United States Department of Housing and Urban Development.

Attachments:

- Form of Agreement to Enter Into Housing Assistance Payments Contract, including all exhibits
- Form of Housing Assistance Payment Contract
- Form of Consent to Assignment

Brianna Lontajo, Principal Management Analyst 9/20/2023

Aaron Gettis, Deputy County Counsel 9/15/2023

**U.S. Department of Housing and Urban Development
Office of Public and Indian Housing**

SECTION 8 PROJECT-BASED VOUCHER PROGRAM

**AGREEMENT TO ENTER INTO A
HOUSING ASSISTANCE PAYMENTS CONTRACT**

NEW CONSTRUCTION OR REHABILITATION

PART I

OMB Burden Statement. The public reporting burden for this collection of information is estimated to average 0.25 hours, including the time for collecting, reviewing and reporting the data. The information is required to establish terms between the PHA and the owner prior to execution of a HAP contract for PBV assistance as provided in §983.152. Assurances of confidentiality are not provided under this collection. Send comments regarding this burden estimate or any other aspect of this collection of information, including suggestions to reduce this burden, to the Office of Public and Indian Housing, US Department of Housing and Urban Development, Washington, DC 20410. HUD may not conduct and sponsor, and a person is not required to respond to, a collection of information unless the collection displays a valid control number.

Privacy Notice. The Department of Housing and Urban Development (HUD) is authorized to collect the information required on this form by 24 CFR § 983.152. The information is being collected to establish the agreement between the PHA and owner prior to execution of a HAP contract for PBV assistance as provided in §983.153. The Personally Identifiable Information (PII) data collected on this form are not stored or retrieved within a system of record.

1.1 Parties

This Agreement to Enter into Housing Assistance Payments Contract (“Agreement”) is between:

Housing Authority of the County of Riverside (“PHA”) and
A0358 Monterey, L.P. (“owner”).

1.2 Purpose

The owner agrees to develop the Housing Assistance Payments Contract (“HAP Contract”) units to in accordance with Exhibit B and to comply with Housing Quality Standards (“HQS”), and the PHA agrees that, upon timely completion of such development in accordance with the terms of the Agreement, the PHA will enter into a HAP Contract with the owner of the Contract units.

1.3 Contents of Agreement

This Agreement consists of Part I, Part II, and the following Exhibits:

EXHIBIT A: The approved owner's PBV proposal. (Selection of proposals must be in accordance with 24 CFR 983.51.)

EXHIBIT B: Description of work to be performed under this Agreement, including:

- if the Agreement is for rehabilitation of units, this exhibit must include the rehabilitation work write-up and, where the PHA has determined necessary, specifications and plans.
- if the Agreement is for new construction of units, the work description must include the working drawings and specifications.
- any additional requirements beyond HQS relating to quality, design and architecture that the PHA requires.
- work items resulting from compliance with the design and construction requirements of the Fair Housing Act and implementing regulations at 24 CFR 100.205, the accessibility requirements under section 504 of the Rehabilitation Act of 1973 and implementing regulations at 24 CFR 8.22 and 8.23, and accessibility requirements under Titles II and III of the Americans with Disabilities Act at 28 CFR parts 35 and 36, as applicable.

EXHIBIT C: Description of housing, including:

- project site.
- total number of units in project covered by this Agreement.
- locations of contract units on site.
- number of contract units by area (size) and number of bedrooms and bathrooms.
- services, maintenance, or equipment to be supplied by the owner without charges in addition to the rent to owner.
- utilities available to the contract units, including a specification of utility services to be paid by the owner (without charges in addition to rent) and utility services to be paid by the tenant.
- estimated initial rent to owner for the contract units.

EXHIBIT D: The HAP contract.

1.4 Significant Dates

- A. Effective Date of the Agreement: The Agreement must be executed promptly after PHA notice of proposal selection to the owner has been given. The PHA may not enter this Agreement with the owner until a subsidy layering review has been performed and an environmental review has been satisfactorily completed in accordance with HUD requirements.

- B. A project may either be a single-stage or multi-stage project. A single-stage project will have the same Agreement effective date for all contract units. A multi-stage project will separate effective dates for each stage.

Single-stage project

- i. Effective Date for all contract units: 10/2/2023

- ii. Date of Commencement of the Work: The date for commencement of work is not later than 60 calendar days after the effective date of this Agreement.

- iii. Time for Completion of Work: The date for completion of the work is not later than 637 calendar days after the effective date of this Agreement.

Multi-Stage Project

Enter the information for each stage upon execution of the Agreement for the corresponding stage.

STAGE	NUMBER OF UNITS	EFFECTIVE DATE	DATE OF COMMENCEMENT OF WORK	TIME FOR COMPLETION OF WORK

1.5 Nature of the Work

- This Agreement is for **New Construction** of units to be assisted by the project-based Voucher program.
- This Agreement is for **Rehabilitation** of units to be assisted by the project-based Voucher program.

1.6 Schedule of Completion

- A. **Timely Performance of Work:** The owner agrees to begin work no later than the date for commencement of work as stated in Section 1.4. In the event the work is not commenced, diligently continued and completed as required under this Agreement, the PHA may terminate this Agreement or take other appropriate action. The owner agrees to report promptly to the PHA the date work is commenced and furnish the PHA with progress reports as required by the PHA.
- B. **Time for Completion:** All work must be completed no later than the end of the period stated in Section 1.4. Where completion in stages is provided for, work related to units included in each stage shall be completed by the stage completion date and all work on all stages must be completed no later than the end of the period stated in Section 1.4.
- C. **Delays:** If there is a delay in the completion due to unforeseen factors beyond the owner’s control as determined by the PHA, the PHA agrees to extend the time for completion for an appropriate period as determined by the PHA in accordance with HUD requirements.

1.7 Changes in Work

- A. The owner must obtain prior PHA approval for any change from the work specific in Exhibit B which would alter the design or quality of the rehabilitation or construction. The PHA is not required to approve any changes requested by the owner. PHA approval of any change may be conditioned on establishment of a lower initial rent to owner at the amounts determined by PHA.

- B. If the owner makes any changes in the work without prior PHA approval, the PHA may establish lower initial rents to owner at the amounts determined by PHA in accordance with HUD requirements.
- C. The PHA (or HUD in the case of insured or coinsured mortgages) may inspect the work during rehabilitation or construction to ensure that work is proceeding on schedule, is being accomplished in accordance with the terms of the Agreement, meets the level of material described in Exhibit B and meets typical levels of workmanship for the area.

1.8 Work completion

- A. Conformance with Exhibit B: The work must be completed in accordance with Exhibit B. The owner is solely responsible for completion of the work.
- B. Evidence of Completion: When the work is completed, the owner must provide the PHA with the following:
 - 1. A certification by the owner that the work has been completed in accordance with the HQS and all requirements of this Agreement.
 - 2. A certification by the owner that the owner has complied with labor standards and equal opportunity requirements in the development of the housing. (See 24 CFR 983.155(b)(1)(ii).)
 - 3. Additional Evidence of Completion: At the discretion of the PHA, or as required by HUD, this Agreement may specify additional documentation that must be submitted by owner as evidence of completion of the housing. Check the following that apply:
 - A certificate of occupancy or other evidence that the contract units comply with local requirements.
 - An architect's or developer's certification that the housing complies with:
 - the HQS;
 - State, local, or other building codes;
 - Zoning;

The rehabilitation work write-up for rehabilitated housing;

The work description for newly constructed housing; or

Any additional design or quality requirements pursuant to this Agreement.

1.9 Inspection and Acceptance by the PHA of Completed Contract Units

- A. Completion of Contract Units: Upon receipt of owner notice of completion of Contract units, the PHA shall take the following steps:
1. Review all evidence of completion submitted by owner.
 2. Inspect the units to determine if the housing has been completed in accordance with this Agreement, including compliance with the HQS and any additional requirements imposed by the PHA under this Agreement.
- B. Non-Acceptance: If the PHA determines the work has not been completed in accordance with this Agreement, including non-compliance with the HQS, the PHA shall promptly notify the owner of this decision and the reasons for the non-acceptance. The parties must not enter into the HAP contract.
- C. Acceptance: If the PHA determines housing has been completed in accordance with this Agreement, and that the owner has submitted all required evidence of completion, the PHA must submit the HAP contract for execution by the owner and must then execute the HAP contract.

1.10 Acceptance where defects or deficiencies are reported:

- A. If other defects or deficiencies exist, the PHA shall determine whether and to what extent the defects or deficiencies are correctable, whether the units will be accepted after correction of defects or deficiencies, and the requirements and procedures for such correction and acceptance.
- B. Completion in Stages: Where completion in stages is provided for, the procedures of this paragraph shall apply to each stage.

1.11. Execution of HAP Contract

- A. Time and Execution: Upon acceptance of the units by the PHA, the owner and the PHA execute the HAP contract.
- B. Completion in Stages: Where completion in stages is provided for the number and types of units in each stage, and the initial rents to owner for such units, shall be separately shown in Exhibit C of the contract for each stage. Upon acceptance of the first stage, the owner shall execute the contract and the signature block provided in the contract for that stage. Upon acceptance of each subsequent stage, the owner shall execute the signature block provided in the contract for such stage.
- C. Form of Contract: The terms of the contract shall be provided in Exhibit D of this Agreement. There shall be no change in the terms of the contract unless such change is approved by HUD headquarters. Prior to execution by the owner, all blank spaces in the contract shall be completed by the PHA.
- D. Survival of owner Obligations: Even after execution of the contract, the owner shall continue to be bound by all owner obligations under the Agreement.

1.12 Initial determination of rents

- A. The estimated amount of initial rent to owner shall be established in Exhibit C of this Agreement.
- B. The initial amount of rent to owner is established at the beginning of the HAP contract term.
- C. The estimated and initial contract rent for each units may in no event exceed the amount authorized in accordance with HUD regulations and requirements. Where the estimated initial rent to owner exceeds the amount authorized in accordance with HUD regulations, the PHA shall establish a lower initial rent tow owner, in accordance with HUD regulations and requirements.

1.13 Uniform Relocation Act

- A. A displaced person must be provided relocation assistance at the levels described in and in accordance with the requirements of the Uniform Relocation Assistance and Real Property Acquisition Policies Act of 1970

(URA) (42 U.S.C. 4201-4655) and implementing regulations at 49 CFR part 24.

- B. The cost of required relocation assistance may be paid with funds provided by the owner, or with local public funds, or with funds available from other sources. Payment of relocation assistance must be paid in accordance with HUD requirements.
- C. The acquisition of real property for a project to be assisted under the program is subject to the URA and 49 CFR part 24, subpart B.
- D. The PHA must require the owner to comply with the URA and 49 CFR part 24.
- E. In computing a replacement housing payment to a residential tenant displaced as a direct result of privately undertaken rehabilitation or demolition of the real property, the term “initiation of negotiations” means the execution of the Agreement between the owner and the PHA.

1.14 Protection of In-Place Families

- A. In order to minimize displacement of in-place families, if a unit to be placed under Contract is occupied by an eligible family on the proposal selection date, the in-place family must be placed on the PHA’s waiting list (if they are not already on the list) and, once their continued eligibility is determined, given an absolute selection preference and referred to the project owner for an appropriately sized unit in the project.
- B. This protection does not apply to families that are not eligible to participate in the program on the proposal selection date.
- C. The term “in-place family” means an eligible family residing in a proposed contract unit on the proposal selection date.
- D. Assistance to in-place families may only be provided in accordance with the program regulations and other HUD requirements.

1.15 Termination of Agreement and Contract

The Agreement or HAP contract may be terminated upon at least 30 days notice to the owner by the PHA or HUD if the PHA or HUD determines that the contract units were not eligible for selection in conformity with HUD requirements.

1.16 Rights of HUD if PHA Defaults Under Agreement

If HUD determines that the PHA has failed to comply with this Agreement or has failed to take appropriate action to HUD's satisfaction or as directed by HUD, for enforcement of the PHA's rights under this Agreement, HUD may assume the PHA's rights and obligations under the Agreement, and may perform the obligations and enforce the rights of the PHA under the Agreement. HUD will, if it determines that the owner is not in default, pay Annual Contributions for the purpose of providing housing assistance payments with respect to the dwelling unit(s) under this Agreement for the duration of the HAP contract.

1.17 Owner Default and PHA Remedies

A. Owner Default

Any of the following is a default by the owner under the Agreement:

1. The owner has failed to comply with any obligation under the Agreement.
2. The owner has violated any obligation under any other housing assistance payments contract under Section 8 of the United States Housing Act of 1937 (42 U.S.C. 1437f).
3. The owner has committed any fraud or made any false statement to the PHA or HUD in connection with the Agreement.
4. The owner has committed fraud, bribery, or any other corrupt or criminal act in connection with any Federal housing assistance program.
5. If the property where the contract units are located is subject to a lien or security interest securing a HUD loan or mortgage insured by HUD and:
 - a. The owner has failed to comply with the regulations for the applicable HUD loan or mortgage insurance program, with the mortgage or mortgage note, or with the regulatory agreement; or
 - b. The owner has committed fraud, bribery, or any other corrupt or criminal act in connection with the HUD loan or HUD-insured mortgage.

6. The owner has engaged in any drug-related criminal activity or any violent criminal activity.

B. PHA Remedies

1. If the PHA determines that a breach has occurred, the PHA may exercise any of its rights or remedies under the Agreement.
2. The PHA must notify the owner in writing of such determination. The notice by the PHA to the owner may require the owner to take corrective action (as verified by the PHA) by a time prescribed in the notice.
3. The PHA's rights and remedies under the Agreement include but are not limited to: (i) terminating the Agreement; and (ii) declining to execute the HAP contract for some or all of the units.

C. PHA Remedy is not Waived

The PHA's exercise or non-exercise of any remedy for owner breach of the Agreement is not a waiver of the right to exercise that remedy or any other right or remedy at any time.

1.18 PHA and Owner Relation to Third Parties

A. Selection and Performance of Contractor

1. The PHA has not assumed any responsibility or liability to the owner, or any other party for performance of any contractor, subcontractor or supplier, whether or not listed by the PHA as a qualified contractor or supplier under the program. The selection of a contractor, subcontractor or supplier is the sole responsibility of the owner and the PHA is not involved in any relationship between the owner and any contractor, subcontractor or supplier.
2. The owner must select a competent contractor to undertake rehabilitation or construction. The owner agrees to require from each prospective contractor a certification that neither the contractor nor its principals is presently debarred, suspended, proposed for debarment, declared ineligible, or voluntarily excluded from participation in contract by the Comptroller General or any federal Department or agency. The owner agrees not to award contracts to, otherwise engage in the service of, or fund any contractor that does not provide this certification.

- B. **Injury Resulting from Work under the Agreement:** The PHA has not assumed any responsibility for or liability to any person, including a worker or a resident of the unit undergoing work pursuant to this Agreement, injured as a result of the work or as a result of any other action or failure to act by the owner, or any contractor, subcontractor or supplier.
- C. **Legal Relationship:** The owner is not the agent of the PHA and this Agreement does not create or affect any relationship between the PHA and any lender to the owner or any suppliers, employees, contractor or subcontractors used by the owner in the implementation of the Agreement.
- D. **Exclusion of Third Party Claims:** Nothing in this Agreement shall be construed as creating any right of any third party (other than HUD) to enforce any provision of this Agreement or the Contract, or to assert any claim against HUD, the PHA or the owner under the Agreement or the Contract.
- E. **Exclusion of owner Claims against HUD:** Nothing in this Agreement shall be construed as creating any right of the owner to assert any claim against HUD.

1.19 PHA-Owned Units

Notwithstanding Section 1.18 of this Agreement, a PHA may own units assisted under the project-based voucher program, subject to the special requirements in 24 CFR 983.59 regarding PHA-owned units.

1.20 Conflict of Interest

- A. **Interest of Members, Officers, or Employees of PHA, Members of Local Governing Body, or Other Public Officials**
 - 1. No present or former member or officer of the PHA (except tenant-commissioners), no employee of the PHA who formulates policy or influences decisions with respect to the housing choice voucher program or project-based voucher program, and no public official or member of a governing body or State or local legislator who exercises functions or responsibilities with respect to these programs, shall have any direct or indirect interest, during his or her tenure or for one year thereafter, in the Agreement or HAP contract.
 - 2. HUD may waive this provision for good cause.

B. Disclosure

The owner has disclosed to the PHA any interest that would be a violation of the Agreement or HAP contract. The owner must fully and promptly update such disclosures.

1.21 Interest of Member or Delegate to Congress

No member of or delegate to the Congress of the United States of America or resident-commissioner shall be admitted to any share or part of the Agreement or HAP contract or to any benefits arising from the Agreement of HAP contract.

1.22 Transfer of the Agreement, HAP Contract, or Property

A. PHA Consent to Transfer

The owner agrees that the owner has not made and will not make any transfer in any form, including any sale or assignment, of the Agreement, HAP contract, or the property without the prior written consent of the PHA. A change in ownership in the owner, such as a stock transfer or transfer of the interest of a limited partner, is not subject to the provisions of this section. Transfer of the interest of a general partner is subject to the provisions of this section.

B. Procedure for PHA Acceptance of Transferee

Where the owner requests the consent of the PHA for a transfer in any form, including any sale or assignment, of the Agreement, the HAP contract, or the property, the PHA must consent to a transfer of the Agreement or HAP contract if the transferee agrees in writing (in a form acceptable to the PHA) to comply with all the terms of the Agreement and HAP contract, if the transferee is acceptable to the PHA. The PHA's criteria for acceptance of the transferee must be in accordance with HUD requirements.

C. When Transfer is Prohibited

The PHA will not consent to the transfer if any transferee, or any principal or interested party, is debarred, suspended, subject to a limited denial of participation, or otherwise excluded under 2 CFR part 2424, or is listed on the U.S. General Services Administration list of parties excluded from Federal procurement or nonprocurement programs.

1.23 Exclusion from Federal Programs

A. Federal Requirements

The owner must comply with and is subject to requirements of 2 CFR part 2424.

B. Disclosure

The owner certifies that:

1. The owner has disclosed to the PHA the identity of the owner and any principal or interested party.
2. Neither the owner nor any principal or interested party is listed on the U.S. General Services Administration list of parties excluded from Federal procurement and nonprocurement programs; and none of such parties are debarred, suspended, subject to a limited denial of participation, or otherwise excluded under 2 CFR part 2424.

1.24 Lobbying Certifications

A. The owner certifies, to the best of the owner's knowledge and belief, that:

1. No Federally appropriated funds have been paid or will be paid, by or on behalf of the owner, to any person for influencing or attempting to influence an officer or employee of any agency, a Member of Congress, an officer or employee of Congress, or an employee of a Member of Congress in connection with the awarding of the Agreement or HAP contract, or the extension, continuation, renewal, amendment, or modification of the HAP contract.
2. If any funds other than Federally appropriated funds have been paid or will be paid to any person for influencing or attempting to influence an officer or employee of any agency, a Member of Congress, an officer or employee of Congress, or an employee of a Member of Congress in connection with the Agreement or HAP contract, the owner must complete and submit Standard Form-LLL, "Disclosure Form to Report Lobbying," in accordance with its instructions.

- B. This certification by the owner is a prerequisite for making or entering into this transaction imposed by 31 U.S.C. 1352.

1.25 Subsidy Layering

- A. Owner Disclosure

The owner must disclose to the PHA, in accordance with HUD requirements, information regarding any related assistance from the Federal government, a State, or a unit of general local government, or any agency or instrumentality thereof, that is made available or is expected to be made available with respect to the contract units. Such related assistance includes, but is not limited to, any loan, grant, guarantee, insurance, payment, rebate, subsidy, credit, tax benefit, or any other form of direct or indirect assistance.

- B. Limit of Payments

Housing assistance payments under the HAP contract must not be more than is necessary, as determined in accordance with HUD requirements, to provide affordable housing after taking account of such related assistance. The PHA will adjust in accordance with HUD requirements the amount of the housing assistance payments to the owner to compensate in whole or in part for such related assistance.

1.26 Prohibition of Discrimination

- A. The owner may not refuse to lease contract units to, or otherwise discriminate against, any person or family in leasing of a contract unit, because of race, color, religion, sex (including sexual orientation and gender identity), national origin, disability, age, or familial status.
- B. The owner must comply with the following requirements:
 - 1. The Fair Housing Act (42 U.S.C. 3601–19) and implementing regulations at 24 CFR part 100 *et seq.*;
 - 2. Executive Order 11063, as amended by Executive Order 12259 (3 CFR 1959–1963 Comp., p. 652, and 3 CFR, 1980 Comp., p. 307) (Equal Opportunity in Housing Programs) and implementing regulations at 24 CFR part 107;

3. Title VI of the Civil Rights Act of 1964 (42 U.S.C. 2000d–2000d–4) (Nondiscrimination in Federally Assisted Programs) and implementing regulations at 24 CFR part 1;
4. The Age Discrimination Act of 1975 (42 U.S.C. 6101–6107) and implementing regulations at 24 CFR part 146;
5. Section 504 of the Rehabilitation Act of 1973 (29 U.S.C. 794) and implementing regulations at 24 CFR part 8;
6. Title II of the Americans with Disabilities Act, 42 U.S.C. 12101 *et seq.*; 28 CFR part 35
7. Executive Order 11246, as amended by Executive Orders 11375, 11478, 12086, and 12107 (3 CFR, 1964–1965 Comp., p. 339; 3 CFR, 1966–1970 Comp., p. 684; 3 CFR, 1966–1970 Comp., p. 803; 3 CFR, 1978 Comp., p. 230; and 3 CFR, 1978 Comp., p. 264, respectively) (Equal Employment Opportunity Programs) and implementing regulations at 41 CFR chapter 60;
8. Executive Order 11625, as amended by Executive Order 12007 (3 CFR, 1971–1975 Comp., p. 616 and 3 CFR, 1977 Comp., p. 139) (Minority Business Enterprise Development); and
9. Executive Order 12138, as amended by Executive Order 12608 (3 CFR, 1977 Comp., p. 393, and 3 CFR, 1987 Comp., p. 245) (Women’s Business Enterprise).
10. HUD’s Equal Access Rule at 24 CFR 5.105.

The PHA and the owner must cooperate with HUD in the conducting of compliance reviews and complaint investigations pursuant to all applicable civil rights statutes, Executive Orders, and all related rules and regulations.

1.27 Owner Duty to Provide Information and Access to HUD and PHA

- A. The owner must furnish any information pertinent to this Agreement as may be reasonably required from time to time by the PHA or HUD. The owner shall furnish such information in the form and manner required by the PHA or HUD.
- B. The owner must permit the PHA or HUD or any of their authorized representatives to have access to the premises during normal business hours and, for the purpose of audit and examination, to have access to any books, documents, papers, and records of the owner to the extent necessary to determine compliance with this Agreement.

1.28 Notices and Owner Certifications

- A. Where the owner is required to give any notice to the PHA pursuant to this Agreement, such notice shall be in writing and shall be given in the manner designated by the PHA.
- B. Any certification or warranty by the owner pursuant to the Agreement shall be deemed a material representation of fact upon which reliance was placed when this transaction was entered into.

1.29 HUD Requirements

- A. The Agreement and the HAP contract shall be interpreted and implemented in accordance with all statutory requirements, and will all HUD requirements, including amendments or changes in HUD requirements. The owner agrees to comply with all such laws and HUD requirements.
- B. HUD requirements are requirements that apply to the project-based voucher program. HUD requirements are issued by HUD Headquarters as regulations, *Federal Register* notices, or other binding program directives.

1.30 Applicability of Part II Provisions — Check All that Apply

Equal Employment Opportunity

Section 2.1 applies only to construction contracts of more than \$10,000.

Labor Standards Requirements

Sections 2.3, 2.7, and 2.9 apply only when this Agreement covers nine or more units.

Flood Insurance

Section 2.10 applies if units are located in areas having special flood hazards and in which flood insurance is available under the National Flood Insurance Program.

EXECUTION OF THE AGREEMENT

I/We, the undersigned, certify under penalty of perjury that the information provided above is true and correct. **WARNING:** Anyone who knowingly submits a false claim or makes a false statement is subject to criminal and/or civil penalties, including confinement for up to 5 years, fines, and civil and administrative penalties. (18 U.S.C. §§ 287, 1001, 1010, 1012; 31 U.S.C. §3729, 3802).

FORM APPROVED COUNTY COUNSEL
BY APB 9/15/2023 DATE
AMRIT P. DHILLON

PUBLIC HOUSING AGENCY (PHA) Name of PHA (Print)
By:
Signature of authorized representative
Housing Authority of the County of Riverside
Name and official title (Print)
Heidi Marshall, Executive Director
Date
OWNER Name of Owner (Print) A0358 Monterey, L.P. A California limited partnership
By:
Signature of authorized representative
See attached
Name and official title (Print)
Date

Exhibit A of AHAP



HOUSING AUTHORITY of the County of Riverside

Main Office
5555 Arlington Avenue
Riverside, CA 92504-2506
(951) 351-0700
Admin FAX (951) 688-6873
Housing FAX (951) 354-6324
TDD (951) 351-9844

January 31, 2023

Mark Bigley
A0357 Palm Desert, L.P.
2000 E. Fourth Street, Suite 205
Santa Ana, CA 92705

Indio Office
44-199 Monroe, Suite B
P.O. Box 1747
Indio, CA 92201-1747
(760) 863-2828
(760) 863-2838 FAX
TDD (760) 863-2830

RE: Crossings at Palm Desert, Palm Desert, CA

Website: harivco.org

Dear Mark Bigley:

The Housing Authority of the County of Riverside (HACR) is pleased to inform you that the above referenced project proposal was selected to receive Project Based Vouchers (PBVs) pursuant to the Request for Proposal (RFP) released by the HACR on March 22, 2022, and RFP 2022-201 on October 27, 2022. The HACR is reserving funding for eighty-seven (87) PBVs for a twenty (20) year contract term for the project that will consist of a total of 176 units.

Term and Proposed Amount of Subsidy:

Unit Size	Units	Subsidy Amount	Monthly	Months/Year	Annual	Term Years	AHAP Term 20 Years
2-Bedroom	43	\$1,900.00	\$81,700.00	12	\$980,400.00	20	\$19,608,000.00
3-Bedroom	44	\$ 2,584.00	\$113,696.00	12	\$1,364,352.00	20	\$27,287,040.00
Total Annual:					\$2,344,752.00	Total:	\$46,895,040.00

Final commitment of the Project Based Vouchers is subject to the following items:

- Project's receipt of all necessary capital funding for the construction of the project, including but not limited to a tax credit allocation.
- Subsidy layering requirements as defined by the U.S. Department of Housing and Urban Development (HUD).
- National Environmental Policy Act Clearance.
- Approval of an Agreement to Enter into Housing Assistance Payments (AHAP) Contract by the HACR's Board of Commissioners.

This commitment is also contingent on continued funding from HUD. In the event of a budget decrease, HACR reserves the right to rescind the commitment up until the execution of an AHAP contract. This letter of commitment is valid until December 31, 2023, all financing must be secured by this deadline. Requests for extensions will not be considered. Therefore, all evidence of secured financing must be provided on or before December 31, 2023. If you have any questions, please feel free to contact Nicole Sanchez at (760) 863-2825 or via e-mail at NiSanchez@rivco.org

Thank you,

A handwritten signature in blue ink, appearing to read "Michael Walsh", with a long horizontal flourish extending to the right.

Michael Walsh
Deputy Director
Housing Authority of the County of Riverside

Exhibit B of AHAP

Crossings at Palm Desert

DESCRIPTION

The Crossings at Palm Desert is new construction of 176 low-income housing units for large families. The unit mix will be one-bedroom/one-bath units, two-bedroom/two-bath units and three-bedroom/two bath units. Two 2-bedroom/2 bath unit will be utilized as a management unit. Affordability will be at or below 80% of the area median income with the average AMI at 46.4%. There are no market rate units.

Type	Units
One-bedroom, one bath	44
Two-bedroom, two baths	78
Three-bedroom, two baths	52
two 2BR/2BA Mgmt Units	2
Total	176

The rectangular site is an approximate gross area of 11.8 acres. The gated and fenced site will have access points from Gateway Drive on the west and Dick Kelly Drive on the north. A pedestrian gate will be added on the eastern side along Cortesia Way when the future elementary school of the Palm Desert School District along with a park adjacent on the south of the site are developed.

The one-bedroom units average 583 sf. The two-bedroom units are either 820 sf or 944 sf. The three-bedroom units are 1,082 sf.

The project will consist of five two-story, and four three-story, garden style walk-up buildings containing 16 units or 24 units each (8 units per floor). The community room is approximately 4,414 sf and is a one-story structure. The community room will have a full kitchen, computer lab, on-site leasing office/manager office, media room and service provider office. There will be an outdoor barbeque/picnic/open turf area/tot lot area, and swimming pool. There will be three laundry rooms, one in the Community Center and two standalone laundry buildings. There will be a minimum of 18 washers and 18 dryers.

The project will have 352 parking spaces, of which 176 will be carport covered spaces and 176 uncovered spaces.

Apartment amenities include a patio/balcony, dishwasher, refrigerator, range, garbage disposal, ceiling fan, and are wired for cable television. All appliances will be Energy Star rated.

The grounds including the courtyard, patio, walkways, community garden, recreational and perimeter areas, will be natively landscaped, which requires less maintenance and lower costs, while enhancing the beauty of the neighborhood.

Sustainable design is applied to active and inactive open space, providing a park-like setting with natural vegetation and drought tolerant plants for all residents to enjoy, improves storm water drainage and treatment.



Sheet Index

ARCHITECTURE:

- A0.1 Cover Sheet
- A1.0 Site Plan
- A2.1 Building Elevations - Building A
- A2.2 Building Elevations - Building B
- A2.3 Building Elevations - Leasing and Amenity Building
- A3.1 Building Plans - Building A
- A3.2 Building Plans - Building B
- A3.3 Building Plans - Leasing and Amenity Building
- A4.0 Building Sections
- A5.0 Unit Plans
- A6.1 Renderings - Building A
- A6.2 Renderings - Building A
- A6.3 Renderings - Building B
- A6.4 Renderings - Building B
- A6.5 Renderings - Leasing and Amenity Building
- A7.0 Trash Enclosure & Laundry Building Exhibit
- A7.1 Material Board
- A7.2 Building Code Analysis
- A7.3 Building Code Analysis
- A7.4 Building Code Analysis

CIVIL:

- GP-01 Preliminary Grading & Drainage Plan
- SP-01 Preliminary Site Plan
- UP-01 Preliminary Utility Plan

LANDSCAPE:

- L1 Preliminary Landscape Plan
- L2 Preliminary Landscape Plan
- L3 Preliminary Landscape Plan
- L4 Preliminary Landscape Plan
- L5 Preliminary Landscape Plan
- L6 Plant Board
- L7 Plant Board

ELECTRICAL:

- E1 Electrical Photometric Plan
- E2 Electrical Photometric Plan

Project Location



Vicinity Map

Project Team:

Owner/ Developer

Urban Housing Communities
2000 E. Fourth Street, Suite 205
Santa Ana, CA 92705
Contact: Mark Bigley

Architecture

KTGY Group, Inc.
17911 Von Karman Ave, Ste 200
Irvine, CA 92614
Contact: Keith Labus

Civil

The Altum Group
44-600 Village Court, Suite 100
Palm Desert, CA 92260
Contact: James Bazua

Landscape

Hermann Design Group
77-899 Wolf Road, Suite 102
Palm Desert, CA 92211
Contact: Ivan Ortiz



Architecture + Planning
958 455-5849
ktgy.com

Urban Housing Communities
2000 E. Fourth Street, Suite 205
Santa Ana, CA 92705

CROSSINGS AT PALM DESERT
PALM DESERT, CA # 2021-0835

CONCEPTUAL DESIGN
MARCH 30TH, 2022

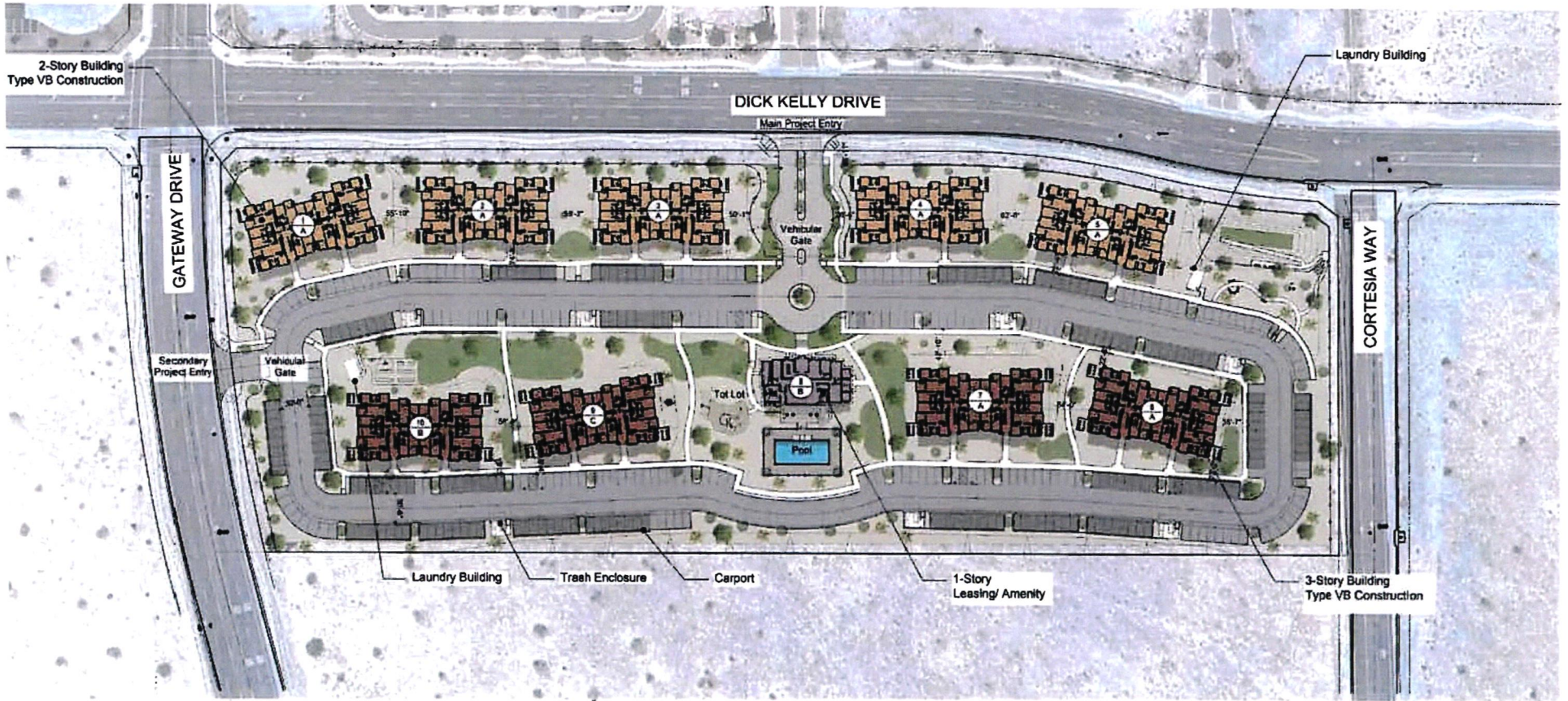

SITE SUMMARY

Site Area	11.8 AC
Total Units	176 DU
Density	14.9 DU/AC

PLAN SUMMARY

Building Type A		Building Type B	
Type	Units	Type	Units
1 Bed	4	1 Bed	6
2 Bed	8	2 Bed	10
3 Bed	4	3 Bed	8
Total	16	Total	24
Buildings	5	Buildings	4

Type	Units	%
1 Bed	44	25.0%
2 Bed	80	45.5%
3 Bed	52	29.5%
Total	176	100.0%

PARKING SUMMARY

Required Parking Per Zoning				Required Parking Per State Density Bonus				Provided Parking	
Type	Units	Ratio	Spaces	Type	Units	Ratio	Spaces	Type	Spaces
1 Bed	44	2.0	88	1 Bed	44	1.0	44	Open	176
2 Bed	80	2.0	160	2 Bed	80	1.5	120	Carpools	176
3 Bed	52	2.0	104	3 Bed	52	1.5	78	Total	362
Total	176		362	Total	176		242		



Architecture + Planning
888.456.5646
ktgy.com

Urban Housing Communities
2000 E. Fourth Street, Suite 205
Santa Ana, CA 92705

CROSSINGS AT PALM DESERT
PALM DESERT, CA # 2021-0635

CONCEPTUAL DESIGN
MARCH 30TH, 2022



SITE PLAN

A1.0

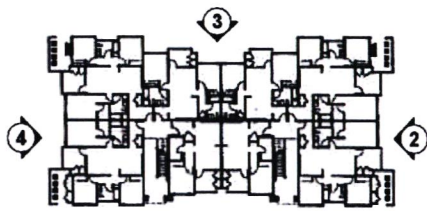

Building Key Plan N.T.S.

Material Legend

- 1. Concrete Shingle Roofing
- 2. Stucco
- 3. Cementitious Siding
- 4. Stone Veneer
- 5. Vinyl Window
- 6. Decorative Light Fixture



1. FRONT ELEVATION



2. RIGHT ELEVATION



3. REAR ELEVATION



4. LEFT ELEVATION



Architecture • Planning
888 456 5849
ktgy.com

Urban Housing Communities
2000 E. Fourth Street, Suite 205
Santa Ana, CA 92705

CROSSINGS AT PALM DESERT
PALM DESERT, CA # 2021-0835

CONCEPTUAL DESIGN
MARCH 30TH, 2022



BUILDING ELEVATIONS
BUILDING TYPE A

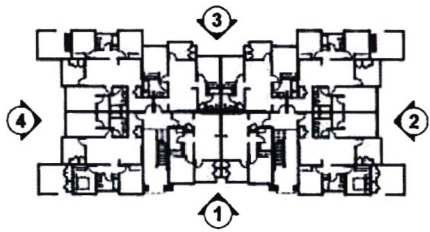

Building Key Plan N.T.S.

Material Legend

- 1. Concrete Shingle Roofing
- 2. Stucco
- 3. Cementitious Siding
- 4. Stone Veneer
- 5. Vinyl Window
- 6. Decorative Light Fixture



1. FRONT ELEVATION



2. RIGHT ELEVATION



3. REAR ELEVATION



4. LEFT ELEVATION



Architecture + Planning
888 458 5848
ktgy.com

Urban Housing Communities
2000 E. Fourth Street, Suite 205
Garden Area, CA 92705

CROSSINGS AT PALM DESERT
PALM DESERT, CA # 2021-0835

CONCEPTUAL DESIGN
MARCH 30TH, 2022

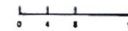

BUILDING ELEVATIONS
BUILDING TYPE B

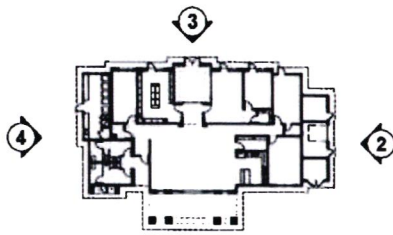

- Material Legend**
- 1. Concrete Shingle Roofing
 - 2. Stucco
 - 3. Cementitious Siding
 - 4. Stone Vener
 - 5. Vinyl Window
 - 6. Decorative Light Fixture

Building Key Plan N.T.S. **1**

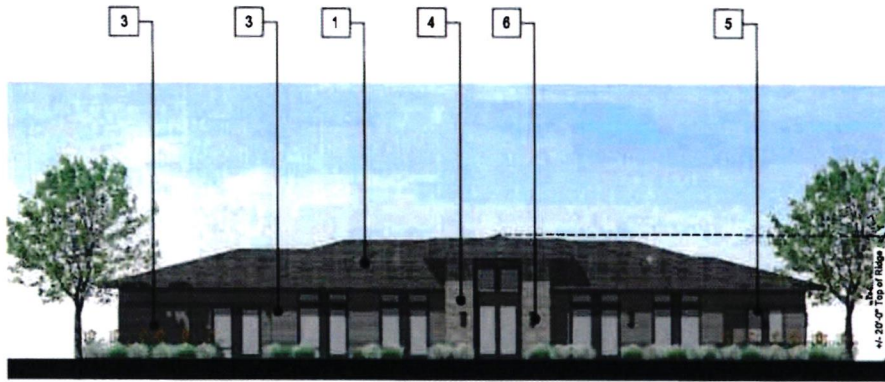

1. FRONT ELEVATION



2. RIGHT ELEVATION



3. REAR ELEVATION

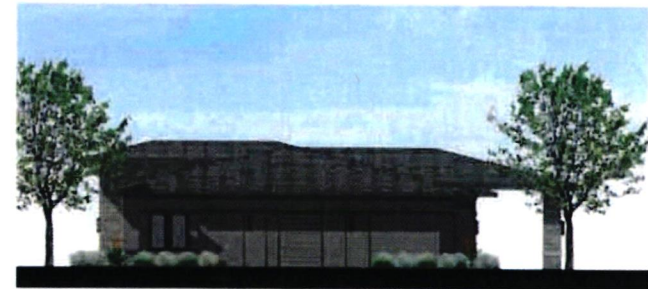

4. LEFT ELEVATION



Architecture + Planning
888.456.5849
kitgy.com

Urban Housing Communities
2000 E. Fourth Street, Suite 205
Santa Ana, CA 92705

CROSSINGS AT PALM DESERT
PALM DESERT, CA # 2021-0835

CONCEPTUAL DESIGN
MARCH 30TH, 2022



BUILDING ELEVATIONS
LEASING & AMENITY BUILDING

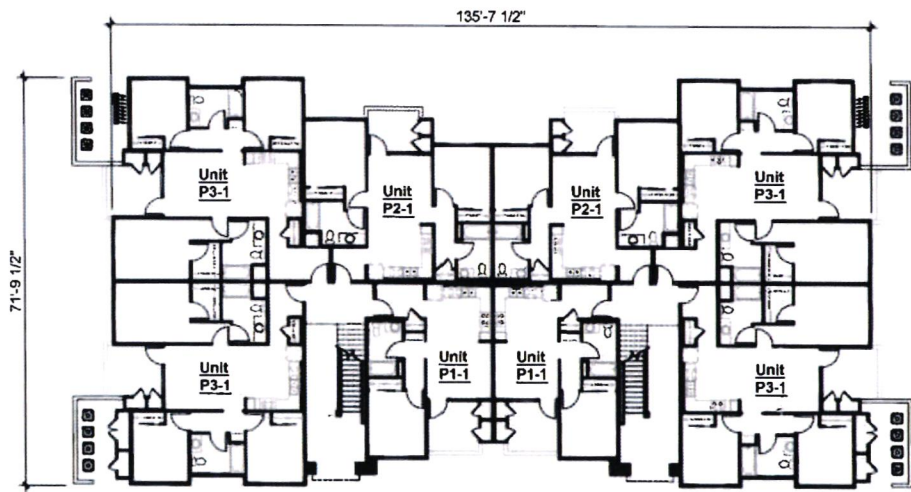

1st Floor

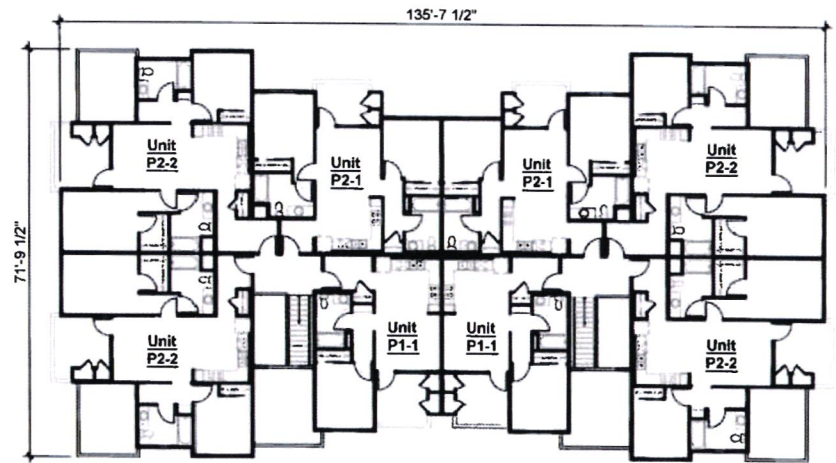

2nd Floor

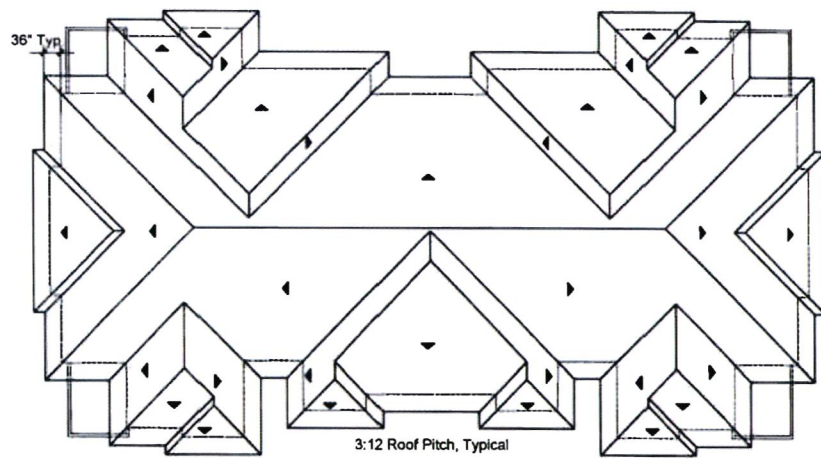

Roof Plan



Architecture + Planning
888.458.5849
kitgy.com

Urban Housing Communities
2000 E. Fourth Street, Suite 205
Santa Ana, CA 92705

CROSSINGS AT PALM DESERT
PALM DESERT, CA # 2021-0835

CONCEPTUAL DESIGN
MARCH 30TH, 2022

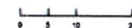

BUILDING PLANS
BUILDING TYPE A

A3.1

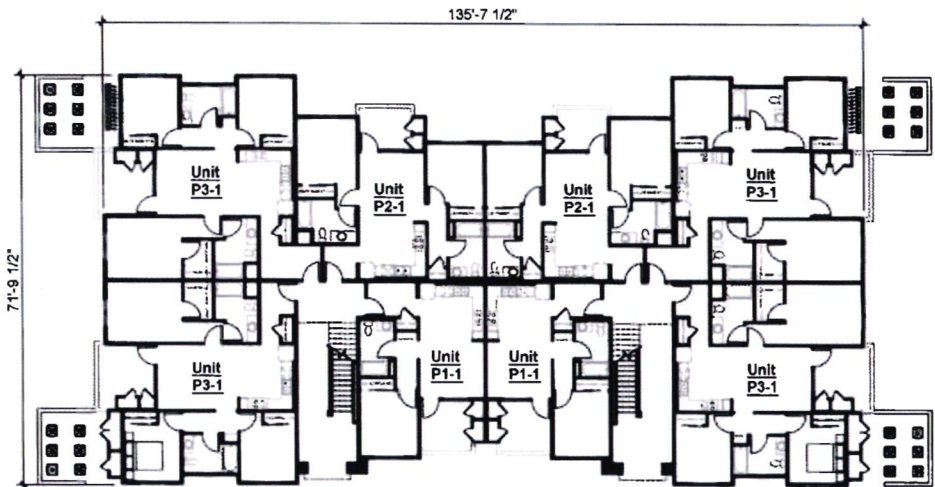

1st Floor

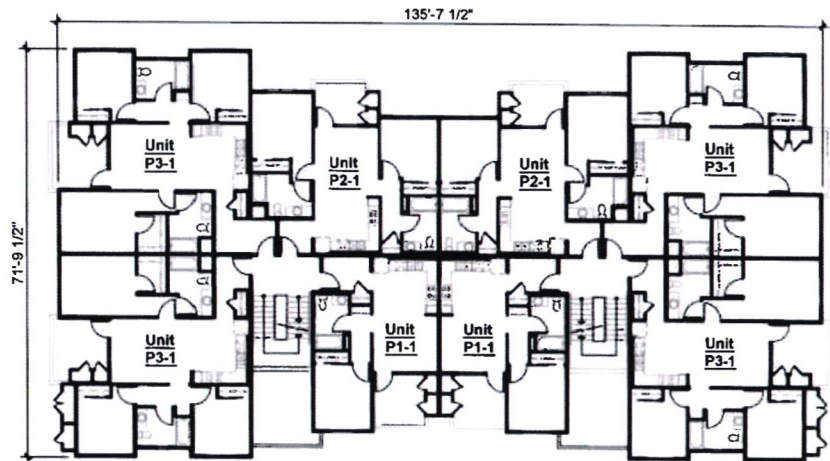

2nd Floor

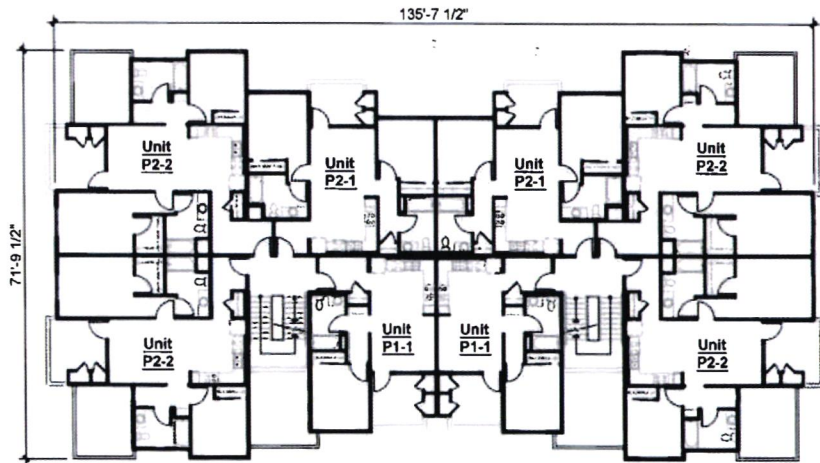

3rd Floor

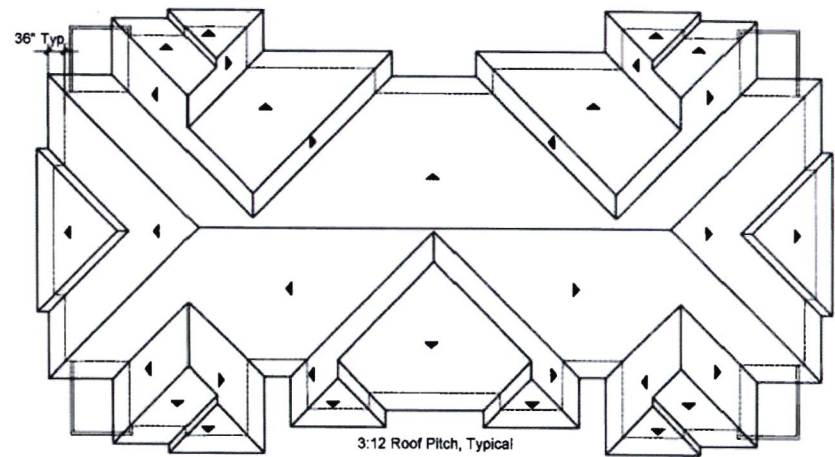

Roof Plan



Architecture + Planning
888.456.5849
ktgy.com

Urban Housing Communities
2000 E. Fourth Street, Suite 205
Santa Ana, CA 92705

CROSSINGS AT PALM DESERT
PALM DESERT, CA # 2021-0835

CONCEPTUAL DESIGN
MARCH 30TH, 2022

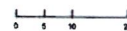

BUILDING PLANS
BUILDING TYPE B

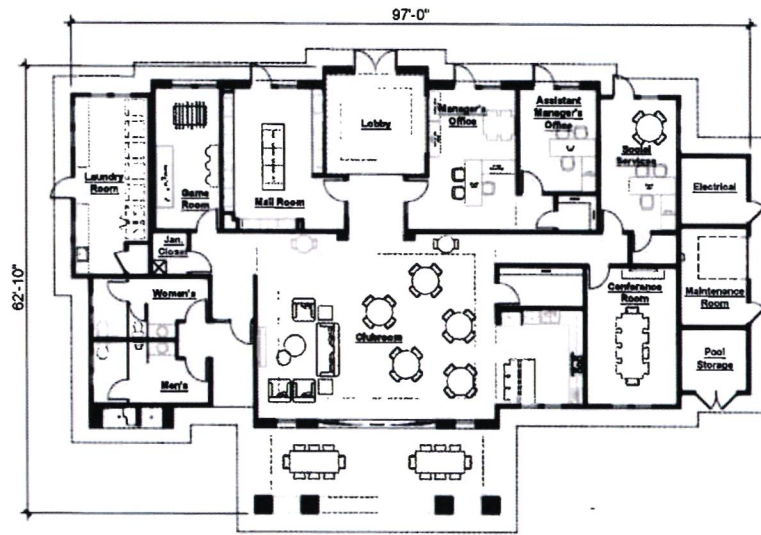

1st Floor

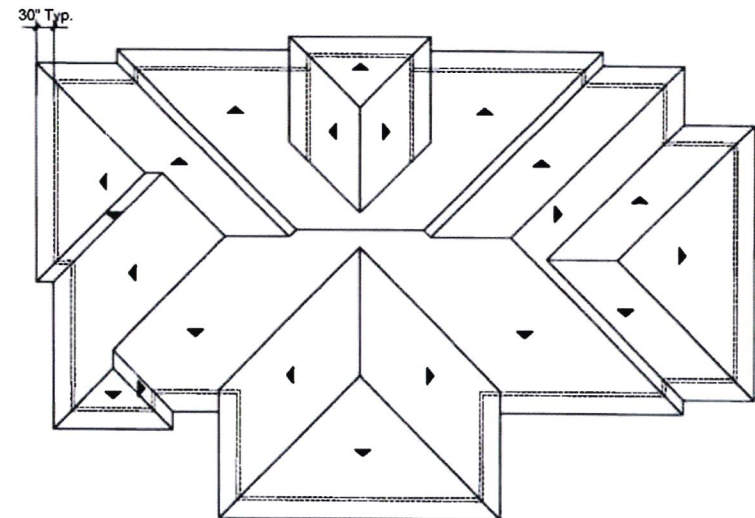

Roof Plan



Architecture + Planning
888.458.5848
ktgy.com

Urban Housing Communities
2000 E. Fourth Street, Suite 205
Santa Ana, CA 92705

CROSSINGS AT PALM DESERT
PALM DESERT, CA # 2021-0835

CONCEPTUAL DESIGN
MARCH 30TH, 2022



BUILDING PLANS
LEASING & AMENITY BUILDING

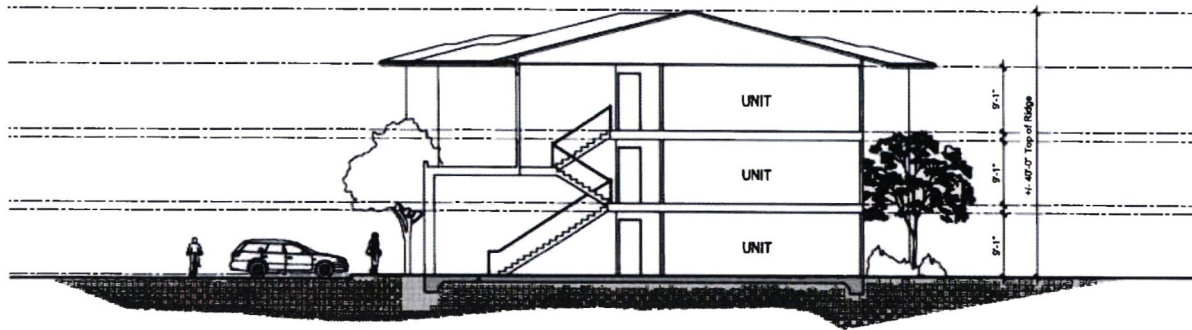
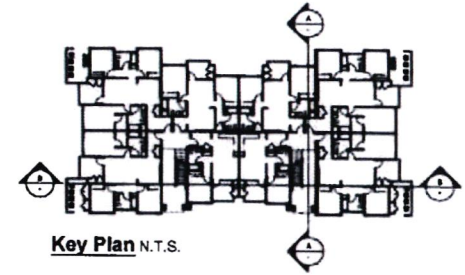

Section A

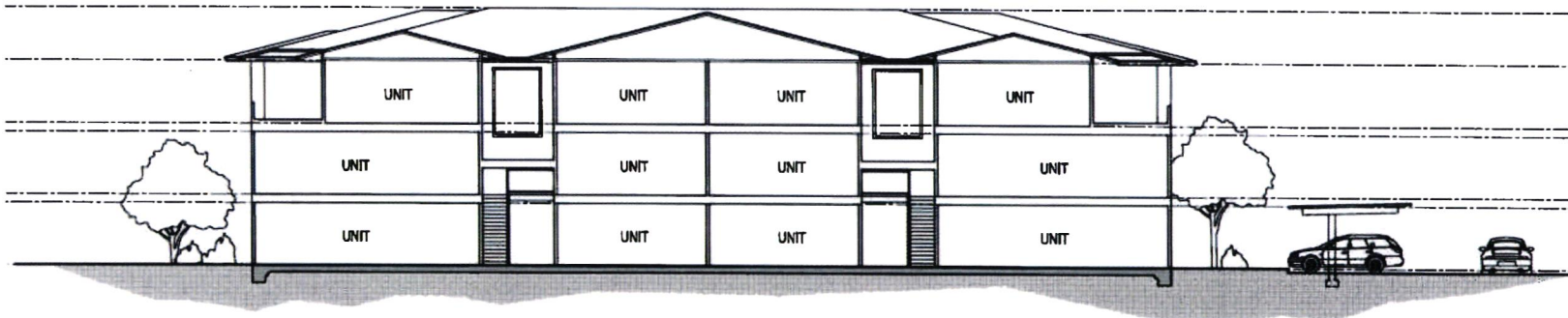

Section B



Architecture + Planning
 888.436.5849
 kitgy.com

Urban Housing Communities
 2000 E. Fourth Street, Suite 205
 Santa Ana, CA 92705

CROSSINGS AT PALM DESERT
 PALM DESERT, CA # 2021-0835

CONCEPTUAL DESIGN
 MARCH 30TH, 2022

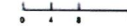

BUILDING SECTIONS
 BUILDING A

A4.0

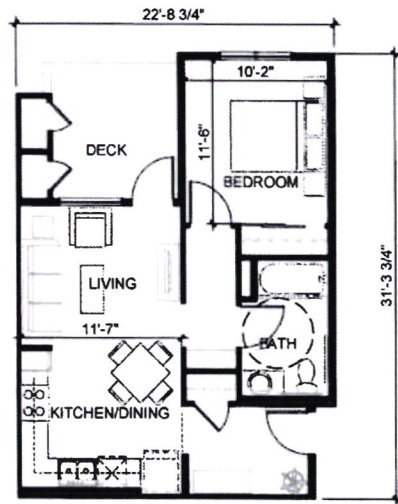

Unit Type 1-1
 1 Bedroom/ 1 Bathroom
 Net Area: 539 SQ. FT.
 Gross Area: 583 SQ. FT.

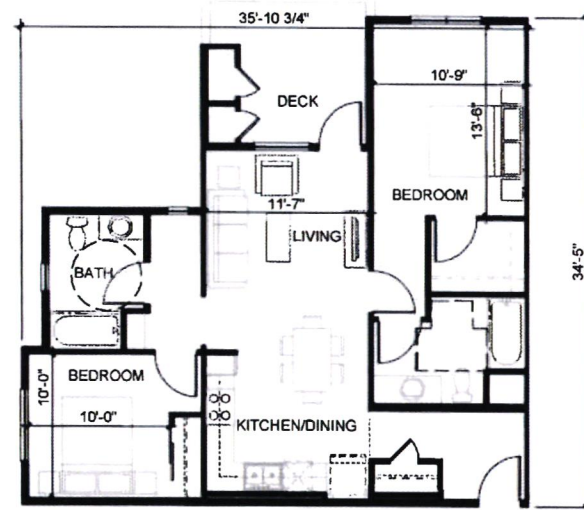

Unit Type 2-2
 2 Bedrooms/ 2 Bathrooms
 Net Area: 882 SQ. FT.
 Gross Area: 944 SQ. FT.

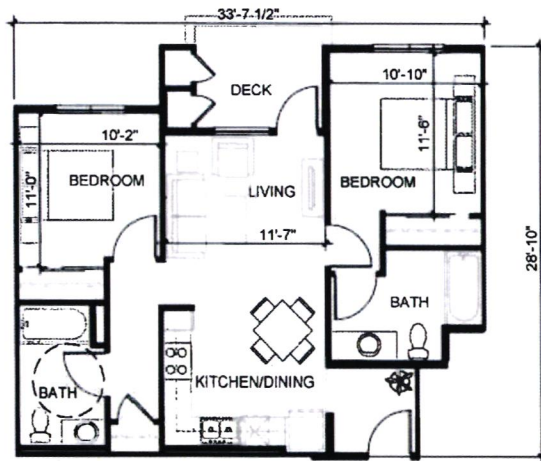

Unit Type 2-1
 2 Bedrooms/ 2 Bathrooms
 Net Area: 772 SQ. FT.
 Gross Area: 820 SQ. FT.

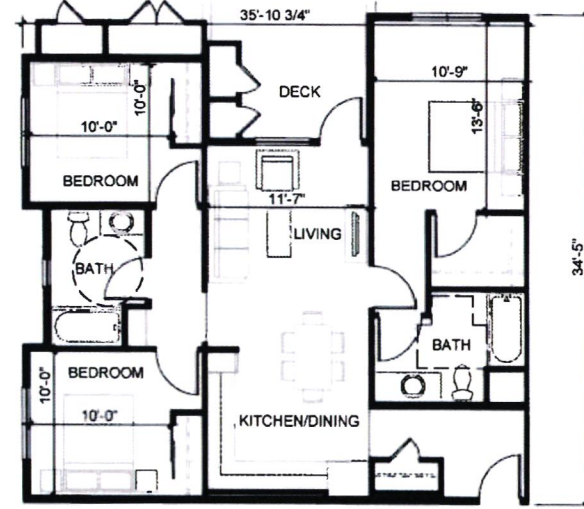

Unit Type 3-1
 3 Bedrooms/ 2 Bathrooms
 Net Area: 1012 SQ. FT.
 Gross Area: 1082 SQ. FT.



Architecture + Planning
 888 450 5849
 kitgy.com

Urban Housing Communities
 2000 E. Fourth Street, Suite 205
 Santa Ana, CA 92705

CROSSINGS AT PALM DESERT
 PALM DESERT, CA # 2021-0835

CONCEPTUAL DESIGN
 MARCH 30TH, 2022



ENLARGED BUILDING PLANS
 UNIT PLANS

A5.0



Note: Conceptual renderings are intended to illustrate the project's architectural elevations. For information on grading and landscape design, see civil and landscape architecture sheets, respectively.



Architecture & Planning
866.453.5414
ktgy.com

Urban Health Communities
2000 E. Fourth Street, Suite 205
Santa Ana, CA 92705

CROSSINGS AT PALM DESERT
PALM DESERT, CA # 201-0635

CONCEPTUAL DESIGN
MARCH 30TH, 2022

RENDERINGS
BUILDING TYPE A - FRONT ELEVATION

A6.1



Note: Conceptual renderings are intended to illustrate the project's architectural elevations. For information on grading and landscape design, see civil and landscape architecture sheets, respectively.



Architecture + Planning
888.456.5848
ktgy.com

Urban Housing Communities
2000 E. Fourth Street, Suite 205
Santa Ana, CA 92705

CROSSINGS AT PALM DESERT
PALM DESERT, CA # 2021-0835

CONCEPTUAL DESIGN
MARCH 30TH, 2022

RENDERINGS
BUILDING TYPE A - REAR ELEVATION

A6.2



Note: Conceptual renderings are intended to illustrate the project's architectural elevations. For information on grading and landscape design, see civil and landscape architecture sheets, respectively.



Architecture + Planning
888.456.5849
ktgy.com

Urban Housing Communities
2000 E. Fourth Street, Suite 205
Santa Ana, CA 92705

CROSSINGS AT PALM DESERT
PALM DESERT, CA # 2021-0635

CONCEPTUAL DESIGN
MARCH 30TH, 2022

RENDERINGS
BUILDING TYPE B - FRONT ELEVATION

A6.3



Note: Conceptual renderings are intended to illustrate the project's architectural elevations. For information on grading and landscape design, see civil and landscape architecture sheets, respectively.



Architecture + Planning
888.456.5849
kitgy.com

Urban Housing Communities
2000 E. Fourth Street, Suite 205
Santa Ana, CA 92705

CROSSINGS AT PALM DESERT
PALM DESERT, CA # 2021-0835

CONCEPTUAL DESIGN
MARCH 30TH, 2022

RENDERINGS
BUILDING TYPE B - REAR ELEVATION



Note: Conceptual renderings are intended to illustrate the project's architectural elevations. For information on grading and landscape design, see civil and landscape architecture sheets, respectively.



Architecture • Planning
888.456.5849
ktgy.com

Urban Housing Committee
2000 E. Fourth Street, Suite 205
Santa Ana, CA 92705

CROSSINGS AT PALM DESERT
PALM DESERT, CA # 2021-0835

CONCEPTUAL DESIGN
MARCH 30TH, 2022

RENDERINGS
LEASING & AMENITIES BUILDING

A6.5

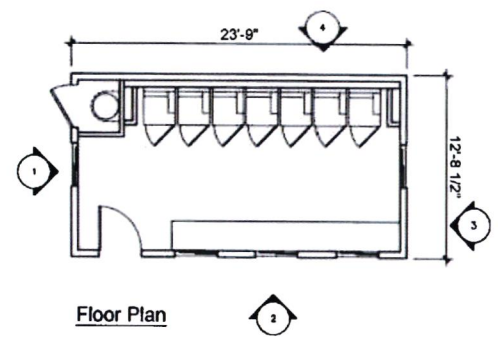
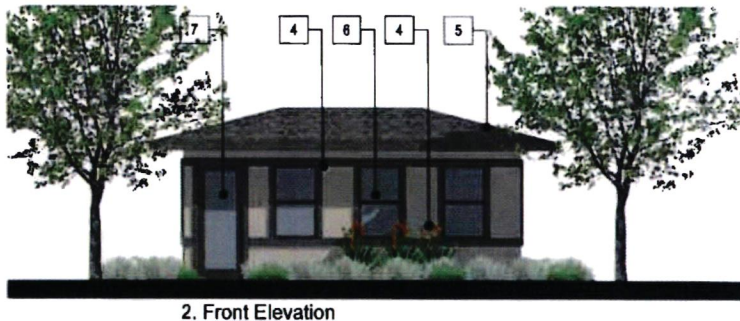
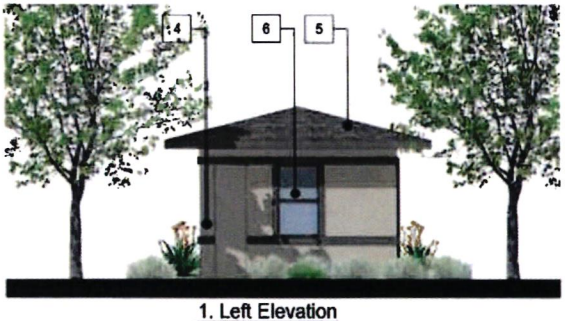
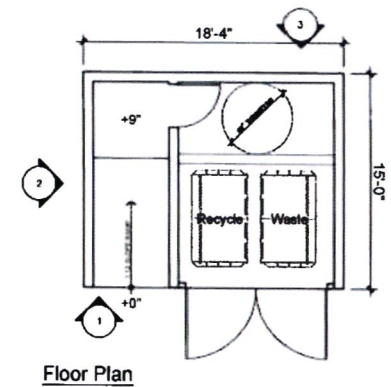
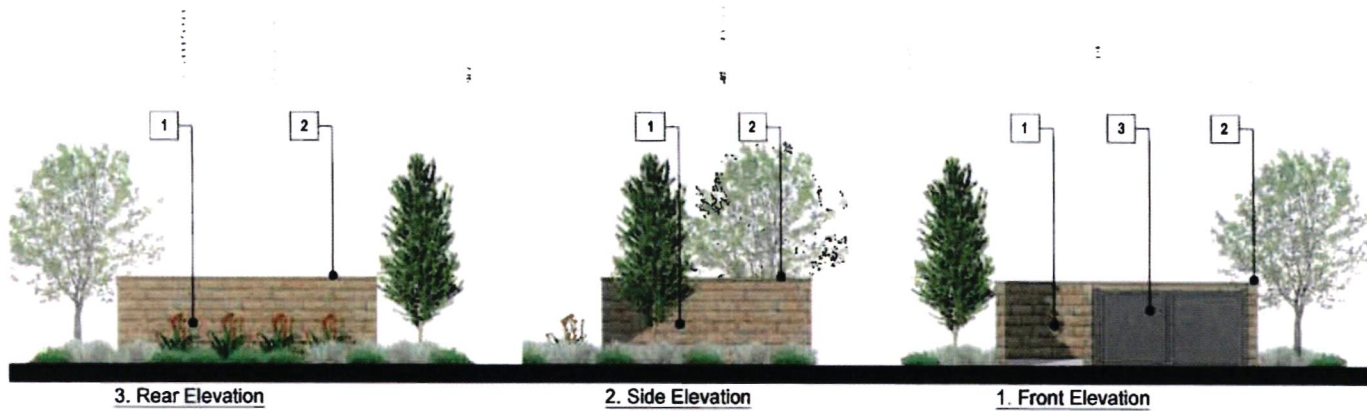

- Material Legend**
1. Tan Split Face CMU
 2. Split Paver Cap
 3. Painted Metal Door with Metal Posts
 4. Stucco
 5. Asphalt Shingles
 6. Vinyl Windows
 7. French Doors



Architecture • Planning
665.456.5249
ktgy.com

Urban Housing Communities
2000 E. Fourth Street, Suite 205
Santa Ana, CA 92705

CROSSINGS AT PALM DESERT
PALM DESERT, CA # 2021-0835

CONCEPTUAL DESIGN
MARCH 30TH, 2022

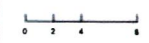

**TRASH ENCLOSURE &
LAUNDRY BUILDING EXHIBIT**
FLOOR PLANS & ELEVATIONS

A7.0

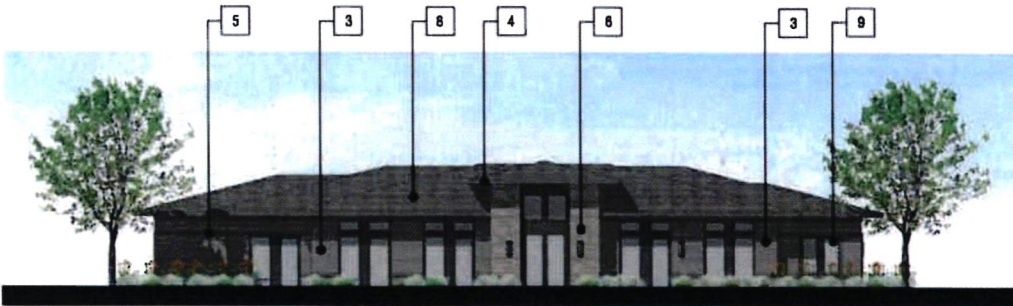

LEASING & AMENITY BUILDING

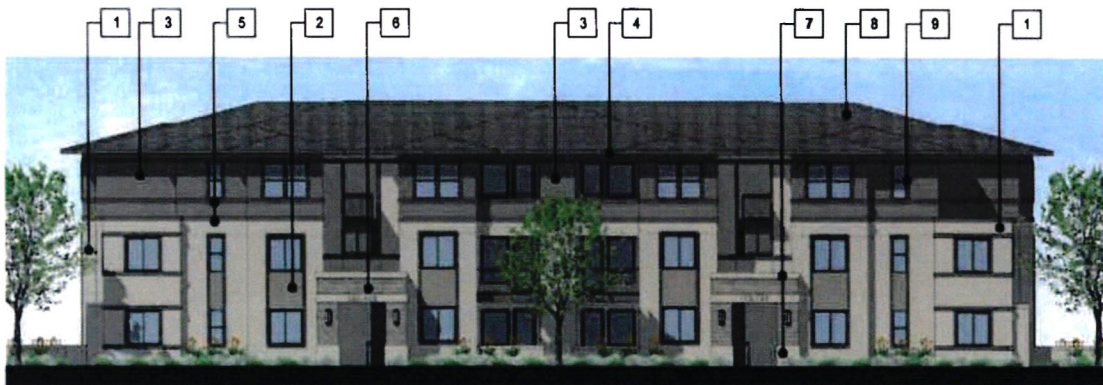

BUILDING B FRONT ELEVATION

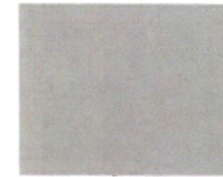

1. BODY 1 (STUCCO)



2. BODY 2 (STUCCO) / TRIM 3



3. CEMENTITIOUS SIDING



4. TRIM 1 (FASCIA)



5. TRIM 2 (BANDING)



6. STONE VENEER
MANUFACTURER: CORONADO
PROFILE: PRAIRIE STONE
COLORWAY: MOCHA GRANITE

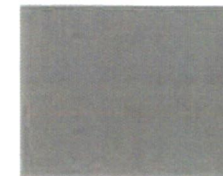

7. TRIM AT STONE VENEER



8. ROOFING
MANUFACTURER: EAGLE ROOFING
PROFILE: BEL AIR - CALIFORNIA
COLORWAY: 4689 - BROWN RANGE



9. VINYL WINDOW
ESPRESSO



Architecture • Planning
888.456.5849
kitgy.com

Urban Housing Communities
2000 E. Fourth Street, Suite 205
Santa Ana, CA 92705

CROSSINGS AT PALM DESERT
PALM DESERT, CA # 2021-0835

CONCEPTUAL DESIGN
MARCH 30TH, 2022

MATERIAL BOARD

A7.1

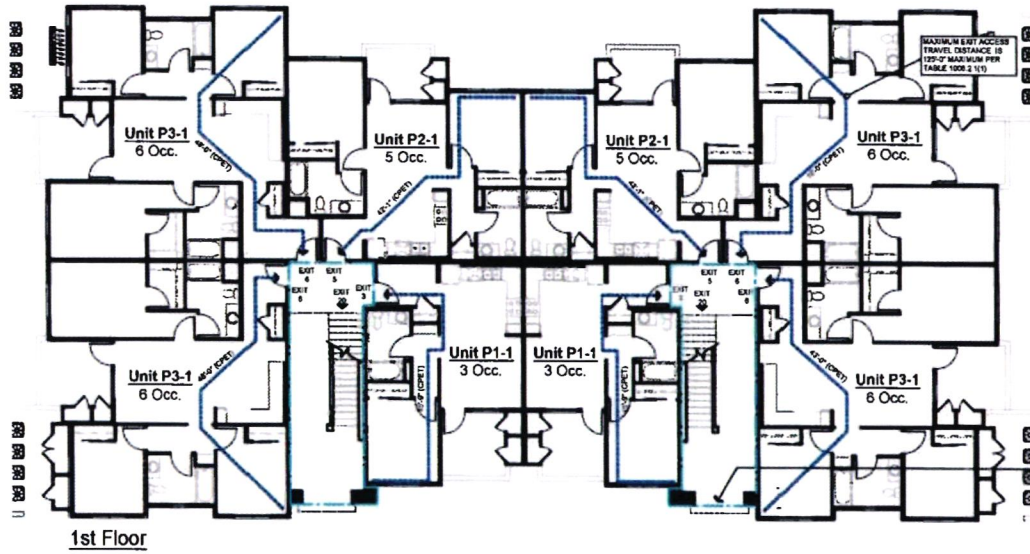

Exit Stairs serving the project shall comply with CBC Table 1006.3.2(1) and requirements for R-2 occupancies served by one exit. All components of the egress system shall be sized adequately for the occupant load of the building.

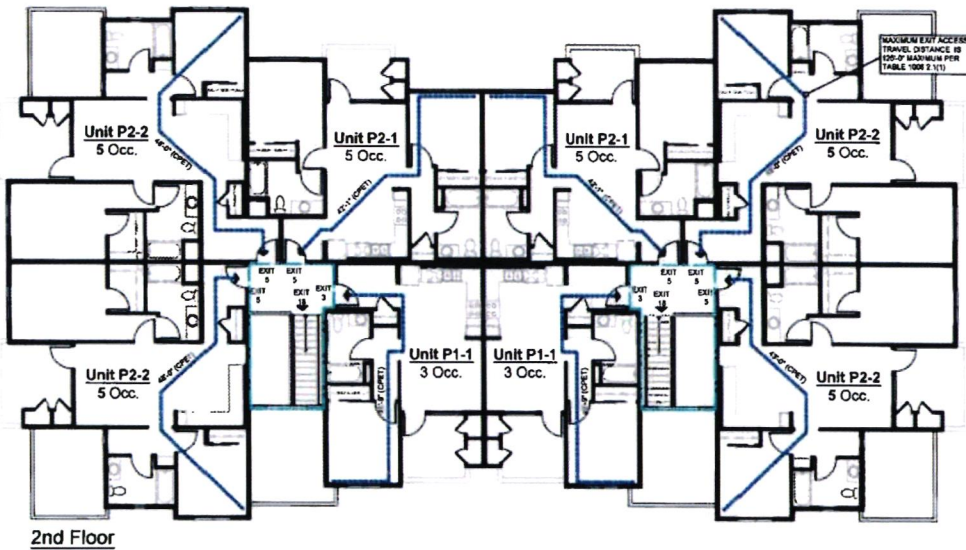

Building Code Analysis	
Construction Type	VB
Occupancy Type	R-2
Sprinkler System	NFPA 13
Building Height Analysis:	
Allowed Building Height (without area increase)	3 Stories 60 feet
Proposed Building Height	2 Stories
Building Area Analysis:	
Single-Occupancy, Multistory Building	
Allowed Building Area Per Floor	9,100sf (assuming an area factor increase of 0.3)
Allowed Building Area	18,200sf (assuming an area factor increase of 0.3)
Proposed Building Area	
1st Floor	8,540sf
2nd Floor	7,740sf
Total	16,280sf



Architecture + Planning
888.456.5849
ktgy.com

Urban Housing Communities
2000 E. Fourth Street, Suite 205
Santa Ana, CA 92705

CROSSINGS AT PALM DESERT
PALM DESERT, CA # 2021-0835

CONCEPTUAL DESIGN
MARCH 30TH, 2022

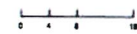

BUILDING CODE ANALYSIS
BUILDING TYPE A

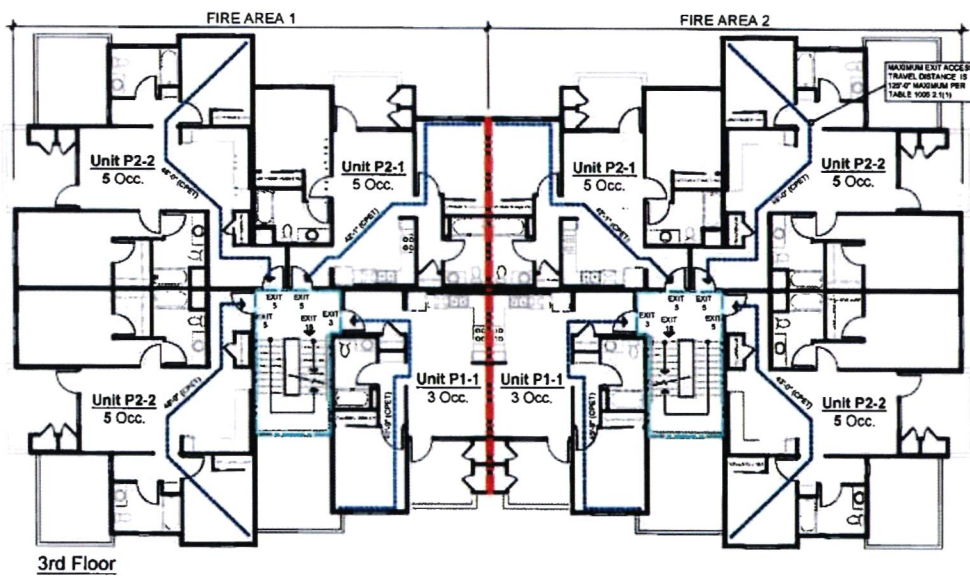
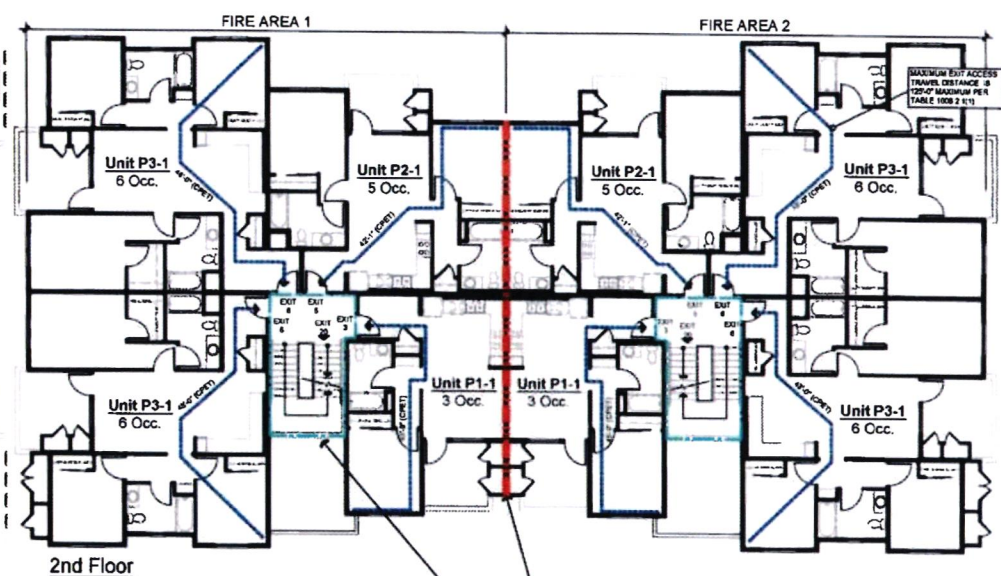
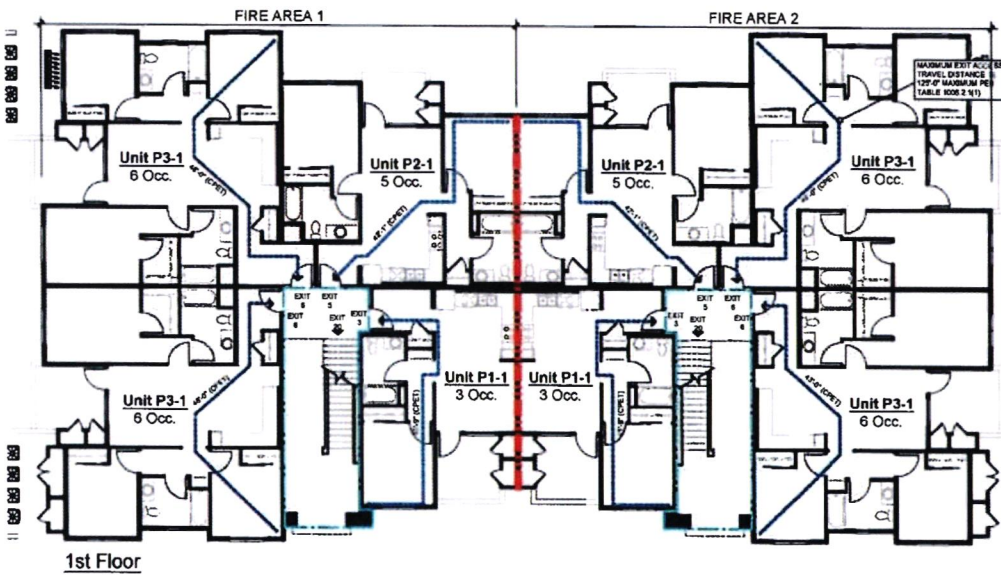

2-Hour Fire Wall

Exit Stairs serving the project shall comply with CBC Table 1006.3.2(1) and requirements for R-2 occupancies served by one exit. All components of the egress system shall be sized adequately for the occupant load of the building.

Building Code Analysis

Construction Type	VB
Occupancy Type	R-2
Sprinkler System	NEPA 13

Building Height Analysis:

Allowed Building Height (without area increase)	3 Stories
Proposed Building Height	60 feet
	3 Stories

Building Area Analysis:

Single-Occupancy, Multistory Building

Allowed Building Area Per Floor	7,000 sf
Allowed Building Area	14,000 sf

Proposed Building Area

	FIRE AREA 1	FIRE AREA 2
1st Floor	4,270 sf	4,270 sf
2nd Floor	4,135 sf	4,135 sf
3rd Floor	3,870 sf	3,870 sf
Total	12,275 sf	12,275 sf



Architecture + Planning
866.458.5949
ktgy.com

Urban Housing Communities
2000 E. Fourth Street, Suite 206
Santa Ana, CA 92705

CROSSINGS AT PALM DESERT
PALM DESERT, CA # 2021-0635

CONCEPTUAL DESIGN
MARCH 30TH, 2022

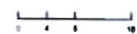

BUILDING CODE ANALYSIS
BUILDING TYPE B

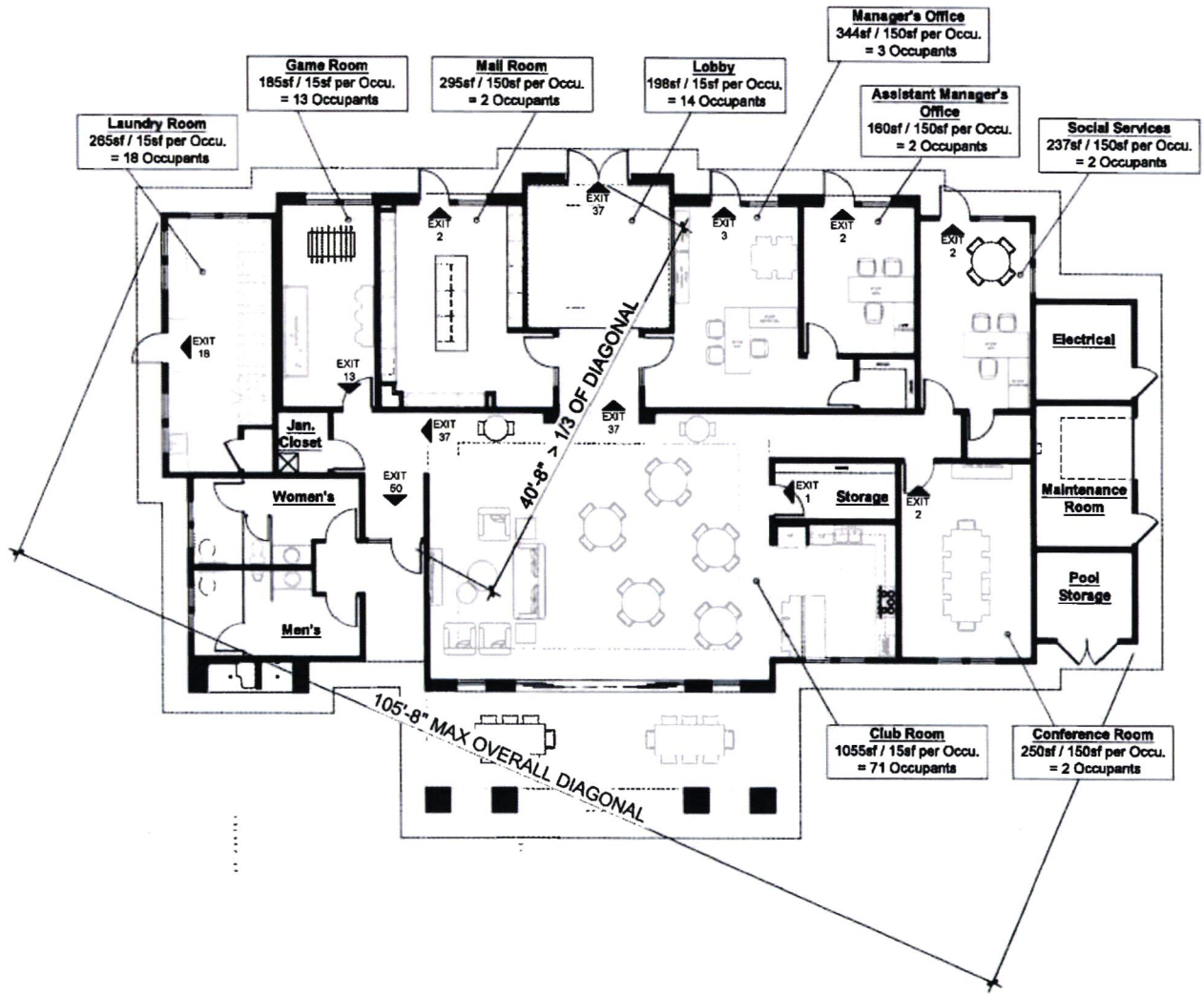

Building Code Analysis
 Construction Type VB
 Occupancy Type A-3, B
 Sprinkler System NFPA 13R

Building Height Analysis:
 Allowed Building Height 2 Story*
 (without area increase) 70 feet*
 Proposed Building Height 1 Story

Building Area Analysis:
 Mixed-Occupancy, One-Story Building
 Allowed Building Area 24,000 sf
 Proposed Building Area 4,414 sf
 1st Floor 4,414 sf
 Total 4,414 sf

Note:* Allowed Building Height and Building Area are based on most strict occupancy group (A-3).



Architecture + Planning
 888.406.5848
 kgy.com

Urban Housing Communities
 2000 E. Fourth Street, Suite 200
 Santa Ana, CA 92705

CROSSINGS AT PALM DESERT
 PALM DESERT, CA © 2021-0835

CONCEPTUAL DESIGN
 MARCH 30TH, 2022



BUILDING CODE ANALYSIS
 LEASING & AMENITY BUILDING

A7.4

Exhibit C of AHAP

EXHIBIT C

Project Name: Crossings at Palm Desert

73500 Dick Kelly Drive

Palm Desert, California 92211

APN: 694-130-017; 694-130-018; 694-130-019; 694-130-020

Total Number of Project Based Voucher (PBV) Units in Project Covered by HAP Contract: 87

Total Number Units in the Project: 176

Description and Quantity in Project:

Unit Mix Summary

1 -bedroom units	44
2-bedroom units	78
3-bedroom units	52
Manager's units	2 (2-bedroom unit)

Project Based Section 8 Voucher: *Accessible with mobility feature **Accessible with communication feature

Project Based Voucher: *Accessible with mobility feature **Accessible with communication feature

Bedroom/Bathroom	AMI	Quantity	Unit #s and Accessible Features
Two Bedroom/ Two Bathroom	30%	36	1-102; 1-200; 1-202; 1-206; 2-102*; 2-200; 2-202; 2-206; 3-102; 3-200; 3-202**; 3-206; 4-102*; 4-200; 4-202; 4-206; 5-102*; 5-200; 5-202; 5-206; 6-102*; 6-202; 6-301; 6-302; 6-307; 7-202; 7-301; 7-305; 7-307; 9-105; 9-202; 9-301; 9-307; 10-202; 10-301; 10-307
Three Bedroom/ Two Bathroom	30%	51	1-100*; 1-101; 1-106**; 1-107; 2-100*; 2-101; 2-106; 2-107; 3-100*; 3-101; 3-106**; 3-107; 4-100; 4-101; 4-106*; 4-107**; 5-100; 5-101; 5-106*; 5-107; 6-100; 6-101; 6-106; 6-107**; 6-200; 6-201; 6-206; 6-207; 7-100; 7-101**; 7-106; 7-107*; 7-200; 7-201; 7-206; 7-207; 9-101; 9-106**; 9-107*; 9-200; 9-201; 9-206; 9-207; 10-100; 10-101; 10-106; 10-107*; 10-200; 10-201; 10-206; 10-207
	Total	87 Units	

Initial Rent to Owner for Contract Units (net of HACR utility allowance):

- Contract rent for
 - 2br \$2,211 - \$142 (Utility Allowance) = \$2,069 Contract Rent
 - 3br \$2,977 - \$183 (Utility Allowance) = \$2,794 Contract Rent

Services, Maintenance, and Equipment to be Provided by the Owner Without Charges in Addition to Rent to Owner:

Building

- Maintenance of building exterior, interior, and site areas
- Common area recreational space, interior and exterior
- On-site surface parking
- Swimming pool

Laundry

- Common laundry machines – machines purchased and maintained by Owner; Residents pay per use

Kitchen Appliances

- Stove/Oven
- Garbage Disposal
- Refrigerator
- Dishwasher

Services

- 1 full time case manager
- Adult education, health and wellness, or skill building classes. Includes but is not limited to financial literacy, computer training, home-buyer education, GED, resume building, ESL, nutrition, exercise, health information/awareness, art, parenting, on-site food cultivation and preparation, and smoking cessation classes. Minimum of 84 hours of instruction per year
- After School Childcare. This includes but is not limited to: homework assistance, organized group activities, supervised open play, etc. Minimum of 15 hours of instruction each week during the school year.

Utilities

- Sewer
- Electric (heating/cooling, cooking, water heating)
- Water
- Trash
- Telephone/Cable
- Internet

Utilities paid by Owner:

water, sewer, trash

Utilities paid by Residents:

Electricity, Telephone/cable, internet

Exhibit D of AHAP

**U.S. Department of Housing and Urban Development
Office of Public and Indian Housing**

**SECTION 8 PROJECT-BASED VOUCHER PROGRAM
HOUSING ASSISTANCE PAYMENTS CONTRACT**

NEW CONSTRUCTION OR REHABILITATION

PART 1 OF HAP CONTRACT

OMB Burden Statement. The public reporting burden for this collection of information is estimated to average 1 hour, including the time for collecting, reviewing and reporting the data. This form is required to establish terms between a PHA and owner to provide housing assistance. This contract allows a PHA to enter into a HAP contract with the owner to provide housing assistance payments for eligible families. Assurances of confidentiality are not provided under this collection. Send comments regarding this burden estimate or any other aspect of this collection of information, including suggestions to reduce this burden, to the Office of Public and Indian Housing, US. Department of Housing and Urban Development, Washington, DC 20410. HUD may not conduct and sponsor, and a person is not required to respond to, a collection of information unless the collection displays a valid control number.

Privacy Notice. The Department of Housing and Urban Development (HUD) is authorized to collect the information required on this form by 24 CFR § 983.202. The information sets forth the PHA and owner's agreement to provide housing under the project-based component of the Housing Choice Voucher Program. The Personally Identifiable Information (PII) data collected on this form are not stored or retrieved within a system of record.

1. CONTRACT INFORMATION

a. Parties

This housing assistance payments (HAP) contract is entered into between:

Housing Authority of the County of Riverside (PHA) and

A0358 Monterey, L.P. (owner).

b. Contents of contract

The HAP contract consists of Part 1, Part 2, and the contract exhibits listed in paragraph c.

c. Contract exhibits

The HAP contract includes the following exhibits:

**Project-Based Voucher Program
HAP Contract for New Construction/Rehab**

Previous editions are obsolete

**HUD 52530A Page - 1 of Part 1
(04/2023)**

- EXHIBIT A:** TOTAL NUMBER OF UNITS IN PROJECT COVERED BY THIS HAP CONTRACT; INITIAL RENT TO OWNER; AND DESCRIPTION OF THE CONTRACT UNITS. (See 24 CFR 983.203 for required items.) If this is a multi-stage project, this exhibit must include a description of the units in each completed phase.
- EXHIBIT B:** SERVICES, MAINTENANCE AND EQUIPMENT TO BE PROVIDED BY THE OWNER WITHOUT CHARGES IN ADDITION TO RENT TO OWNER
- EXHIBIT C:** UTILITIES AVAILABLE IN THE CONTRACT UNITS, INCLUDING A LISTING OF UTILITY SERVICES TO BE PAID BY THE OWNER (WITHOUT CHARGES IN ADDITION TO RENT TO OWNER) AND UTILITIES TO BE PAID BY THE TENANTS
- EXHIBIT D:** FEATURES PROVIDED TO COMPLY WITH PROGRAM ACCESSIBILITY FEATURES OF SECTION 504 OF THE REHABILITATION ACT OF 1973 AND IMPLEMENTING REGULATIONS AT 24 CFR PART 8

ADDITIONAL EXHIBITS

- d. Single-Stage and Multi-Stage Contracts (place a check mark in front of the applicable project description).**

Single-Stage Project

This is a single-stage project. For all contract units, the effective date of the HAP contract is:

_____.

Multi-Stage Project

This is a multi-stage project. The units in each completed stage are designated in Exhibit A.

The PHA enters the effective date for each stage after completion and PHA acceptance of all units in that stage. The PHA enters the effective date for each stage in the "Execution of HAP contract for contract units completed and accepted in stages" (starting on page 9).

The annual anniversary date of the HAP contract for all contract units in this multi-stage project is the anniversary of the effective date of the HAP contract for the contract units included in the first stage. The expiration date of the HAP contract for all of the contract units completed in stages must be concurrent with the end of the HAP contract term for the units included in the first stage (see 24 CFR 983.207(c)).

e. Term of the HAP contract

1. Beginning of term

The PHA may not enter into a HAP contract for any contract unit until the PHA (or an independent entity, as applicable) has determined that the unit meets PBV inspection requirements. The term of the HAP contract for any unit begins on the effective date of the HAP contract.

2. Length of initial term

a. Subject to paragraph 2.b, the initial term of the HAP contract for any contract units is:

20 years

b. The initial term of the HAP contract for any unit may not be less than one year, nor more than twenty years.

3. Extension of term

The PHA and owner may agree to enter into an extension of the HAP contract at the time of initial HAP contract execution, or any time prior to expiration of the contract. Any extension, including the term of such extension, must be in accordance with HUD requirements. A PHA must determine that any extension is appropriate to achieve long-term affordability of the housing or expand housing opportunities.

4. Requirement for sufficient appropriated funding

a. The length of the initial term and any extension term shall be subject to availability, as determined by HUD, or by the PHA in accordance with HUD requirements, of sufficient appropriated funding (budget authority), as provided in appropriations acts and in the PHA's annual contributions contract (ACC) with HUD, to make full payment of housing assistance payments due to the

owner for any contract year in accordance with the HAP contract.

- b. The availability of sufficient funding must be determined by HUD or by the PHA in accordance with HUD requirements. If it is determined that there may not be sufficient funding to continue housing assistance payments for all contract units and for the full term of the HAP contract, the PHA has the right to terminate the HAP contract by notice to the owner for all or any of the contract units. Such action by the PHA shall be implemented in accordance with HUD requirements.

f. Occupancy and payment

1. Payment for occupied unit

During the term of the HAP contract, the PHA shall make housing assistance payments to the owner for the months during which a contract unit is leased to and occupied by an eligible family. If an assisted family moves out of a contract unit, the owner may keep the housing assistance payment for the calendar month when the family moves out (“move-out month”). However, the owner may not keep the payment if the PHA determines that the vacancy is the owner’s fault.

2. Vacancy payment

THE PHA HAS DISCRETION WHETHER TO INCLUDE THE VACANCY PAYMENT PROVISION (PARAGRAPH f.2), OR TO STRIKE THIS PROVISION FROM THE HAP CONTRACT FORM.

- a. If an assisted family moves out of a contract unit, the PHA may provide vacancy payments to the owner for a PHA-determined vacancy period extending from the beginning of the first calendar month after the move-out month for a period not exceeding two full months following the move-out month.
- b. The vacancy payment to the owner for each month of the maximum two-month period will be determined by the PHA, and cannot exceed the monthly rent to owner under the assisted lease, minus any portion of the rental payment received by the owner (including amounts available from the tenant’s security deposit). Any vacancy payment may cover only the period the unit remains vacant.

- c. The PHA may make vacancy payments to the owner only if:
 - 1. The owner gives the PHA prompt, written notice certifying that the family has vacated the unit and the date when the family moved out (to the best of the owner's knowledge and belief);
 - 2. The owner certifies that the vacancy is not the fault of the owner and that the unit was vacant during the period for which payment is claimed;
 - 3. The owner certifies that it has taken every reasonable action to minimize the likelihood and length of vacancy; and
 - 4. The owner provides any additional information required and requested by the PHA to verify that the owner is entitled to the vacancy payment.
- d. The PHA must take every reasonable action to minimize the likelihood and length of vacancy.
- e. The owner may refer families to the PHA for placement on the PBV waiting list.
- f. The owner must submit a request for vacancy payments in the form and manner required by the PHA and must provide any information or substantiation required by the PHA to determine the amount of any vacancy payments.

3. PHA is not responsible for family damage or debt to owner

Except as provided in this paragraph f (Occupancy and Payment), the PHA will not make any other payment to the owner under the HAP contract. The PHA will not make any payment to the owner for any damages to the unit, or for any other amounts owed by a family under the family's lease.

g. Income-mixing requirement

- 1. Except as provided in paragraphs g.2 through g.5 below, the PHA will not make housing assistance payments under the HAP contract for more than

the greater of 25 units or 25 percent of the total number of dwelling units (assisted or unassisted) in any project. The term “project” means a single building, multiple contiguous buildings, or multiple buildings on contiguous parcels of land assisted under this HAP contract.

2. The limitation in paragraph g.1 does not apply to single-family buildings.
3. In referring eligible families to the owner for admission to the number of contract units in any project exceeding the 25 unit or 25 percent limitation under paragraph g.1, the PHA shall give preference to the applicable families as listed in g.8 below, for the number of contract units exclusively made available for occupancy by such families. The owner shall rent that number of contract units to such families referred by the PHA from the PHA waiting list.
4. Up to the greater of 25 units or 40 percent of units (instead of the greater of 25 units or 25 percent of units) in a project may be project-based if the project is located in a census tract with a poverty rate of 20 percent or less.
5. Units that were previously subject to certain federal rent restrictions or receiving another type of long-term housing subsidy provided by HUD do not count toward the income-mixing requirement if, in the five years prior to issuance of the Request for Proposal or notice of owner selection (for projects selected based on a prior competition or without competition), the unit received one of the forms of HUD assistance or was under a federal rent restriction as described in g.6 and g.7, below.
6. The following specifies the number of contract units (if any) that received one of the following forms of HUD assistance:
 - Public Housing or Operating Funds;
 - Project-Based Rental Assistance (including Mod Rehab and Mod Rehab Single-Room Occupancy);
 - Housing for the Elderly (Section 202 or the Housing Act of 1959);
 - Housing for Persons with Disabilities (Section 811 of the Cranston-Gonzalez Affordable Housing Act);
 - Rent Supplement Program;
 - Rental Assistance Program;

**Project-Based Voucher Program
HAP Contract for New Construction/Rehab**

Previous editions are obsolete

Flexible Subsidy Program.

Place a check mark in front of the form of assistance received by any of the contract units. The following total number of contract units received a form of HUD assistance listed above:

_____.

If all of the units in the project received such assistance, then skip number g.8, below.

7. The following specifies the number of contract units (if any) that were under any of the following federal rent restrictions:

- Section 236;
- Section 221(d)(3) or (d)(4) BMIR (below-market interest rate);
- Housing for the Elderly (Section 202 or the Housing Act of 1959);
- Housing for Persons with Disabilities (Section 811 of the Cranston-Gonzalez Affordable Housing Act);
- Flexible Subsidy Program.

Place a check mark in front of the type of federal rent restriction that applied to any of the contract units. The following total number of contract units were subject to a federal rent restriction listed above:

_____.

If all of the units in the project were subject to a federal rent restriction, then skip number g.8, below.

8. The following specifies the number of contract units (if any) exclusively made available to elderly families, families eligible for supportive services, or eligible youth receiving Family Unification Program or Foster Youth to Independence (FUP/FYI) assistance:

- a Place a check mark here if any contract units are exclusively made available for occupancy by elderly families; The following number of contract units shall be rented to elderly families:

_____.

- b. Place a check mark here if any contract units are exclusively made available for occupancy by families eligible for supportive services. The following number of contract units shall be rented to families eligible for supportive services:
- _____.
- c. Place a check mark here if any contract units are exclusively made available for occupancy by eligible youth receiving FUP/FYI assistance. The following number of contract units shall be rented to eligible youth receiving FUP/FYI assistance:
- _____.
9. The PHA and owner must comply with all HUD requirements regarding income mixing.

EXECUTION OF HAP CONTRACT FOR SINGLE-STAGE PROJECT

I/We, the undersigned, certify under penalty of perjury that the information provided above is true and correct.
WARNING: Anyone who knowingly submits a false claim or makes a false statement is subject to criminal and/or civil penalties, including confinement for up to 5 years, fines, and civil and administrative penalties. (18 U.S.C. §§ 287, 1001, 1010, 1012; 31 U.S.C. §3729, 3802).

FORM APPROVED COUNTY COUNSEL
BY: AMRIT P. DHILLON DATE: 9/15/2023

PUBLIC HOUSING AGENCY (PHA) Name of PHA (Print) Housing Authority of the County of Riverside
By: Signature of authorized representative
Name and official title (Print) Heidi Marshal, Executive Director
Date
OWNER Name of Owner (Print) A0358 Monterey, L.P. A California limited partnership
By: Signature of authorized representative
See attached
Name and official title (Print)
Date

Previous editions are obsolete

**Project-Based Voucher Program
HAP Contract for New Construction/Rehab**

**HUD 52530A Page - 9 of Part 1
(04/2023)**

**EXECUTION OF HAP CONTRACT FOR CONTRACT UNITS COMPLETED
AND ACCEPTED IN STAGES**

(For multi-stage projects, at acceptance of each stage, the PHA and the owner sign the HAP contract execution for the completed stage.)

I/We, the undersigned, certify under penalty of perjury that the information provided above is true and correct.
WARNING: Anyone who knowingly submits a false claim or makes a false statement is subject to criminal and/or civil penalties, including confinement for up to 5 years, fines, and civil and administrative penalties. (18 U.S.C. §§ 287, 1001, 1010, 1012; 31 U.S.C. §3729, 3802).

STAGE NO. 1: The Contract is hereby executed for the contract units in this stage.
STAGE EFFECTIVE DATE: The effective date of the Contract for this stage is:
Date
PUBLIC HOUSING AGENCY (PHA) Name of PHA (Print)
By:
Signature of authorized representative
Name and official title (Print)
Date
OWNER Name of Owner (Print)
By:
Signature of authorized representative
Name and official title (Print)
Date

Previous editions are obsolete

**Project-Based Voucher Program
HAP Contract for New Construction/Rehab**

**HUD 52530A Page - 10 of Part 1
(04/2023)**

STAGE NO. 2: The Contract is hereby executed for the contract units in this stage. STAGE EFFECTIVE DATE: The effective date of the Contract for this stage is:
Date
PUBLIC HOUSING AGENCY (PHA) Name of PHA (Print)
By: Signature of authorized representative
Name and official title (Print)
Date
OWNER Name of Owner (Print)
By: Signature of authorized representative
Name and official title (Print)
Date

STAGE NO. 3: The Contract is hereby executed for the contract units in this stage. STAGE EFFECTIVE DATE: The effective date of the Contract for this stage is:
Date
PUBLIC HOUSING AGENCY (PHA) Name of PHA (Print)
By:
Signature of authorized representative
Name and official title (Print)
Date
OWNER Name of Owner (Print)
By:
Signature of authorized representative
Name and official title (Print)
Date

STAGE NO. __: The Contract is hereby executed for the contract units in this stage. STAGE EFFECTIVE DATE: The effective date of the Contract for this stage is:
Date
PUBLIC HOUSING AGENCY (PHA) Name of PHA (Print)
By:
Signature of authorized representative
Name and official title (Print)
Date
OWNER Name of Owner (Print)
By:
Signature of authorized representative
Name and official title (Print)
Date

Exhibit A of HAP

EXHIBIT A

Project Name: Crossings at Palm Desert

73500 Dick Kelly Drive

Palm Desert, California 92211

APN: 694-130-017; 694-130-018; 694-130-019; 694-130-020

Total Number of Project Based Voucher (PBV) Units in Project Covered by HAP Contract: 87

Total Number Units in the Project: 176

Description and Quantity in Project:

Unit Mix Summary

1 -bedroom units	44
2-bedroom units	78
3-bedroom units	52
Manager's units	2 (2-bedroom unit)

Project Based Section 8 Voucher: *Accessible with mobility feature **Accessible with communication feature

Project Based Voucher: *Accessible with mobility feature **Accessible with communication feature

Bedroom/Bathroom	AMI	Quantity	Unit #s and Accessible Features
Two Bedroom/ Two Bathroom	30%	36	1-102; 1-200; 1-202; 1-206; 2-102*; 2-200; 2-202; 2-206; 3-102; 3-200; 3-202**; 3-206; 4-102*; 4-200; 4-202; 4-206; 5-102*; 5-200; 5-202; 5-206; 6-102*; 6-202; 6-301; 6-302; 6-307; 7-202; 7-301; 7-305; 7-307; 9-105; 9-202; 9-301; 9-307; 10-202; 10-301; 10-307
Three Bedroom/ Two Bathroom	30%	51	1-100*; 1-101; 1-106**; 1-107; 2-100*; 2-101; 2-106; 2-107; 3-100*; 3-101; 3-106**; 3-107; 4-100; 4-101; 4-106*; 4-107**; 5-100; 5-101; 5-106*; 5-107; 6-100; 6-101; 6-106; 6-107**; 6-200; 6-201; 6-206; 6-207; 7-100; 7-101**; 7-106; 7-107*; 7-200; 7-201; 7-206; 7-207; 9-101; 9-106**; 9-107*; 9-200; 9-201; 9-206; 9-207; 10-100; 10-101; 10-106; 10-107*; 10-200; 10-201; 10-206; 10-207
	Total	87 Units	

Initial Rent to Owner for Contract Units (net of HACR utility allowance):

- Contract rent for
 - 2br \$2,211 - \$142 (Utility Allowance) = \$2,069 Contract Rent
 - 3br \$2,977 - \$183 (Utility Allowance) = \$2,794 Contract Rent

Exhibit B of HAP

HAP EXHIBIT B

Services, Maintenance, and Equipment to be Provided by the Owner Without Charges in Addition to Rent to Owner:

Building

- Maintenance of building exterior, interior, and site areas
- Common area recreational space, interior and exterior
- On-site surface parking
- Swimming pool

Laundry

- Common laundry machines – machines purchased and maintained by Owner; Residents pay per use

Kitchen Appliances

- Stove/Oven
- Garbage Disposal
- Refrigerator
- Dishwasher

Services

- 1 full time case manager
- Adult education, health and wellness, or skill building classes. Includes but is not limited to financial literacy, computer training, home-buyer education, GED, resume building, ESL, nutrition, exercise, health information/awareness, art, parenting, on-site food cultivation and preparation, and smoking cessation classes. Minimum of 84 hours of instruction per year
- After School Childcare. This includes but is not limited to: homework assistance, organized group activities, supervised open play, etc. Minimum of 15 hours of instruction each week during the school year.

Exhibit C of HAP

HAP EXHIBIT C

Utilities

- Sewer
- Electric (heating/cooling, cooking, water heating)
- Water
- Trash
- Telephone/Cable
- Internet

Utilities paid by Owner:

water, sewer, trash

Utilities paid by Residents:

Electricity, Telephone/cable, internet

Exhibit D of HAP

HAP EXHIBIT D

Features Provided to Comply with Program Accessibility Features of Section 504 of the Rehabilitation Act of 1973

At Section 504 Accessible Units

Building 1: Unit 1-100

Building 2: Unit 2-100; 2-102;

Building 3: Unit 3-100

Building 4: Unit 4-102; 4-106

Building 5: Unit 5-102; 5-106

Building 6: Unit 6-102

Building 7: Unit 1-107

Building 9: Unit 9-107

Building 10: Unit 10-107

Units:

- Ground floor units
- Accessible path to unit entrance
- Accessible path within the unit to all rooms
- Kitchens - countertops at 34" height
- Kitchens - upper cabinets at 46" max to lower shelf
- Kitchens – 30" long accessible work counter space
- Kitchens - Adaptable cabinets (removable base and doors)
- Kitchens - sink depth 6" or less
- Bathrooms - appropriate toilet clearances, grab bars; vanity height and faucet clearances; grab bars as required
- Bathrooms – appropriate tub/shower clearances

At Units for Visually or Hearing Impaired

Building 1: Unit 1-106

Building 3: Unit 3-106; 3-202

Building 6: Unit 6-107

Building 7-107

Building 9: 9-106

Units:

- Visual/flashing doorbell
- Additional audible/visual fire alarms

**U.S. Department of Housing and Urban Development
Office of Public and Indian Housing**

SECTION 8 PROJECT-BASED VOUCHER PROGRAM

**HOUSING ASSISTANCE PAYMENTS CONTRACT
NEW CONSTRUCTION OR REHABILITATION**

PART 2 OF HAP CONTRACT

OMB Burden Statement. The public reporting burden for this collection of information is estimated to average 1 hour. This form is required to establish terms between a PHA and owner to provide housing assistance. This contract allows a PHA to enter into a HAP contract with the owner to provide housing assistance payments for eligible families. Assurances of confidentiality are not provided under this collection. Send comments regarding this burden estimate or any other aspect of this collection of information, including suggestions to reduce this burden, to the Office of Public and Indian Housing, US. Department of Housing and Urban Development, Washington, DC 20410. HUD may not conduct and sponsor, and a person is not required to respond to, a collection of information unless the collection displays a valid control number.

2. DEFINITIONS

Agreement. Agreement to enter into HAP Contract between the owner and the PHA. The HAP contract was entered into following new construction or rehabilitation of the contract units by the owner pursuant to an Agreement.

Contract units. The housing units covered by this HAP contract. The contract units are described in Exhibit A.

Controlling interest. In the context of PHA-owned units (see definition below), controlling interest means:

- (a) Holding more than 50 percent of the stock of any corporation; or
- (b) Having the power to appoint more than 50 percent of the members of the board of directors of a non-stock corporation (such as a non-profit corporation); or
- (c) Where more than 50 percent of the members of the board of directors of any corporation also serve as directors, officers, or employees of the PHA; or
- (d) Holding more than 50 percent of all managing member interests in an LLC; or
- (e) Holding more than 50 percent of all general partner interests in a partnership;
or

**Project-Based Voucher Program
HAP Contract for New Construction/Rehab**

Previous editions are obsolete

**HUD 52530A Page - 1 of Part 2
(04/2023)**

(f) Having equivalent levels of control in other ownership structures.

Family. The persons approved by the PHA to reside in a contract unit with assistance under the program.

HAP contract. This housing assistance payments contract between the PHA and the owner. The contract consists of Part 1, Part 2, and the contract exhibits (listed in section 1.c of the HAP contract).

Household. The family and any PHA-approved live-in aide.

Housing assistance payment. The monthly assistance payment by the PHA for a contract unit, which includes: (1) a payment to the owner for rent to the owner under the family's lease minus the tenant rent; and (2) an additional payment to or on behalf of the family if the utility allowance exceeds total tenant payment.

Housing quality standards (HQS). The HUD minimum quality standards for dwelling units occupied by families receiving project-based voucher program assistance.

HUD. U.S. Department of Housing and Urban Development.

HUD requirements. HUD requirements which apply to the project-based voucher program. HUD requirements are issued by HUD headquarters, as regulations, Federal Register notices or other binding program directives.

Newly constructed housing. Housing units that do not exist on the proposal selection date and are developed after the date of selection pursuant to an Agreement between the PHA and owner for use under the project-based voucher program.

Owner. Any person or entity who has the legal right to lease or sublease a unit to a participant.

PHA. Public Housing Agency. The agency that has entered into the HAP contract with the owner. The agency is a public housing agency as defined in the United States Housing Act of 1937 (42 U.S.C. 1437a(b)(6)).

PHA-owned units. A unit is "owned by a PHA" if the unit is in a project that is:

(a) Owned by the PHA (which includes a PHA having a "controlling interest" in the entity that owns the unit; see definition above);

(b) Owned by an entity wholly controlled by the PHA; or

(c) Owned by a limited liability company (LLC) or limited partnership in which the PHA (or an entity wholly controlled by the PHA) holds a controlling interest in the managing member or general partner.

Premises. The building or complex in which a contract unit is located, including common areas or grounds.

Principal or interested party. This term includes a management agent and other persons or entities participating in project management, and the officers and principal members, shareholders, investors, and other parties having a substantial interest in the HAP contract, or in any proceeds or benefits arising from the HAP contract.

Program. The project-based voucher program (see authorization for project-based assistance at 42 U.S.C. 1437f(o)(13)).

Proposal selection date. The date the PHA gives written notice of proposal selection to the owner whose proposal is selected in accordance with the criteria established in the PHA's administrative plan.

Rehabilitated housing. Housing units that exist on the proposal selection date but do not substantially comply with the HQS on that date and are developed pursuant to an Agreement between the PHA and owner for use under the project-based voucher program.

Rent to owner. The total monthly rent payable to the owner under the lease for a contract unit. Rent to owner includes payment for any housing services, maintenance and utilities to be provided by the owner in accordance with the lease.

Tenant. The person or persons (other than a live-in aide) who executes the lease as a lessee of the dwelling unit.

Tenant rent. The portion of the rent to owner payable by the family, as determined by the PHA in accordance with HUD requirements. The PHA is not responsible for paying any part of the tenant rent.

3. **PURPOSE**

- a. This is a HAP contract between the PHA and the owner.
 - b. The purpose of the HAP contract is to provide housing assistance payments for eligible families who lease contract units that comply with
-

**Project-Based Voucher Program
HAP Contract for New Construction/Rehab**

Previous editions are obsolete

**HUD 52530A Page - 3 of Part 2
(04/2023)**

the HUD HQS from the owner.

- c. The PHA must make housing assistance payments to the owner in accordance with the HAP contract for contract units leased and occupied by eligible families during the HAP contract term. HUD provides funds to the PHA to make housing assistance payments to owners for eligible families.

4. RENT TO OWNER; HOUSING ASSISTANCE PAYMENTS

a. Amount of initial rent to owner

The initial rent to owner for each contract unit is stated in Exhibit A, which is attached to and made a part of the HAP contract. At the beginning of the HAP contract term, and until rent to owner is adjusted in accordance with section 5 of the HAP contract, the rent to owner for each bedroom size (number of bedrooms) shall be the initial rent to owner amount listed in Exhibit A.

Place a check mark here if the PHA has elected not to reduce rents below the initial rent to owner.

b. HUD rent requirements

Notwithstanding any other provision of the HAP contract, the rent to owner may in no event exceed the amount authorized in accordance with HUD requirements. The PHA has the right to reduce the rent to owner, at any time, to correct any errors in establishing or adjusting the rent to owner in accordance with HUD requirements. The PHA may recover any overpayment from the owner.

c. PHA payment to owner

1. Each month the PHA must make a housing assistance payment to the owner for a unit under lease to and occupied by an eligible family in accordance with the HAP contract.
2. The monthly housing assistance payment to the owner for a contract unit is equal to the amount by which the rent to owner exceeds the tenant rent.
3. Payment of the tenant rent is the responsibility of the family. The PHA is not responsible for paying any part of the tenant rent, or for paying any other claim by the owner against a family. The PHA is responsible only for making housing assistance payments to the

owner on behalf of a family in accordance with the HAP contract.

4. The owner will be paid the housing assistance payment under the HAP contract on or about the first day of the month for which payment is due, unless the owner and the PHA agree on a later date.
5. To receive housing assistance payments in accordance with the HAP contract, the owner must comply with all the provisions of the HAP contract. Unless the owner complies with all the provisions of the HAP contract, the owner does not have a right to receive housing assistance payments.
6. If the PHA determines that the owner is not entitled to the payment or any part of it, the PHA, in addition to other remedies, may deduct the amount of the overpayment from any amounts due the owner, including amounts due under any other housing assistance payments contract.
7. The owner will notify the PHA promptly of any change of circumstances that would affect the amount of the monthly housing assistance payment, and will return any payment that does not conform to the changed circumstances.

d. Termination of assistance for family

The PHA may terminate housing assistance for a family under the HAP contract in accordance with HUD requirements. The PHA must notify the owner in writing of its decision to terminate housing assistance for the family in such case.

5. ADJUSTMENT OF RENT TO OWNER

a. PHA determination of adjusted rent

1. At each annual anniversary during the term of the HAP contract, the PHA shall adjust the amount of rent to owner, upon request to the PHA by the owner, in accordance with law and HUD requirements. In addition, the PHA shall adjust the rent to owner when there is a ten percent decrease in the published, applicable Fair Market Rent in accordance with 24 CFR 983.302. However, if the PHA has elected within the HAP contract not to reduce rents

below the initial rent to owner, the rent to owner shall not be reduced below the initial rent to owner except in those cases described in 24 CFR 983.302(c)(2).

2. The adjustment of rent to owner shall always be determined in accordance with all HUD requirements. The amount of the rent to owner may be adjusted up or down, in the amount defined by the PHA in accordance with HUD requirements.

b. Reasonable rent

The rent to owner for each contract unit, as adjusted by the PHA in accordance with 24 CFR 983.303, may at no time exceed the reasonable rent charged for comparable units in the private unassisted market, except in cases where the PHA has elected within the HAP contract not to reduce rents below the initial rent to owner. The reasonable rent shall be determined by the PHA in accordance with HUD requirements.

c. No special adjustments

The PHA will not make any special adjustments of the rent to owner.

d. Owner compliance with HAP contract

The PHA shall not approve, and the owner shall not receive, any increase of rent to owner unless all contract units are in accordance with the HQS, and the owner has complied with the terms of the assisted leases and the HAP contract.

e. Notice of rent adjustment

Rent to owner shall be adjusted by written notice by the PHA to the owner in accordance with this section. Such notice constitutes an amendment of the rents specified in Exhibit A.

6. OWNER RESPONSIBILITY

The owner is responsible for:

- a. Performing all management and rental functions for the contract units.
- b. Maintaining the units in accordance with HQS.
- c. Complying with equal opportunity requirements.

- d. Enforcing tenant obligations under the lease.
- e. Paying for utilities and housing services (unless paid by the family under the lease).
- f. Collecting from the tenant:
 - 1. Any security deposit;
 - 2. The tenant rent; and
 - 3. Any charge for unit damage by the family.

7. **OWNER CERTIFICATION**

The owner certifies that at all times during the term of the HAP contract:

- a. All contract units are in good and tenantable condition. The owner is maintaining the premises and all contract units in accordance with the HQS.
- b. The owner is providing all the services, maintenance and utilities as agreed to under the HAP contract and the leases with assisted families.
- c. Each contract unit for which the owner is receiving housing assistance payments is leased to an eligible family referred by the PHA, and the lease is in accordance with the HAP contract and HUD requirements.
- d. To the best of the owner's knowledge, the members of the family reside in each contract unit for which the owner is receiving housing assistance payments, and the unit is the family's only residence.
- e. The owner (including a principal or other interested party) is not the parent, child, grandparent, grandchild, sister, or brother of any member of a family residing in a contract unit unless the PHA has determined that approving leasing of the unit would provide a reasonable accommodation for a family member who is a person with disabilities.
- f. The amount of the housing assistance payment is the correct amount due under the HAP contract.
- g. The rent to owner for each contract unit does not exceed rents charged by the owner for other comparable unassisted units.
- h. Except for the housing assistance payment and the tenant rent as provided

under the HAP contract, the owner has not received and will not receive any payments or other consideration (from the family, the PHA, HUD, or any other public or private source) for rental of the contract unit.

- i. The family does not own, or have any interest in the contract unit. If the owner is a cooperative, the family may be a member of the cooperative.

8. CONDITION OF UNITS

a. Owner maintenance and operation

The owner must maintain and operate the contract units and premises to provide decent, safe and sanitary housing in accordance with the HQS, including performance of ordinary and extraordinary maintenance. The owner must provide all the services, maintenance and utilities set forth in Exhibits B and C, and in the lease with each assisted family.

b. PHA inspections

1. The PHA must inspect each contract unit before execution of the HAP contract. The PHA may not enter into a HAP contract covering a unit until the unit fully complies with the HQS.
2. Before providing assistance to a new family in a contract unit, the PHA must inspect the unit. The PHA may not provide assistance on behalf of the family until the unit fully complies with the HQS.
3. At least biennially during the term of the HAP contract, the PHA must inspect a random sample, consisting of at least 20 percent of the contract units in each building, to determine if the contract units and the premises are maintained in accordance with the HQS. Turnover inspections pursuant to paragraph 2 of this section are not counted toward meeting this biennial inspection requirement.
4. If more than 20 percent of the sample of inspected contract units in a building fail the initial inspection, the PHA must reinspect 100 percent of the contract units in the building.
5. The PHA must inspect contract units whenever needed to determine that the contract units comply with the HQS and that the owner is providing maintenance, utilities, and other services in accordance with the HAP contract. The PHA must take into account complaints and any other information that comes to its attention in scheduling inspections.

c. Violation of the housing quality standards

1. If the PHA determines a contract unit is not in accordance with the HQS, the PHA may exercise any of its remedies under the HAP contract for all or any contract units. Such remedies include termination, suspension or reduction of housing assistance payments, and termination of the HAP contract.
2. The PHA may exercise any such contractual remedy respecting a contract unit even if the family continues to occupy the unit.
3. The PHA shall not make any housing assistance for a dwelling unit that fails to meet the HQS, unless the owner corrects the defect within the period specified by the PHA and the PHA verifies the correction. If a defect is life threatening, the owner must correct the defect within no more than 24 hours. For other defects, the owner must correct the defect within no more than 30 calendar days (or any PHA-approved extension).

d. Maintenance and replacement—owner's standard practice

Maintenance and replacement (including redecoration) must be in accordance with the standard practice for the building concerned as established by the owner.

9. LEASING CONTRACT UNITS

a. Selection of tenants

1. During the term of the HAP contract, the owner must lease all contract units to eligible families selected and referred by the PHA from the PHA waiting list. (See 24 CFR 983.251.)
2. The owner is responsible for adopting written tenant selection procedures that are consistent with the purpose of improving housing opportunities for very low-income families and reasonably related to program eligibility and an applicant's ability to perform the lease obligations.
3. Consistent with HUD requirements, and Federal civil rights and fair housing requirements, the owner may apply its own nondiscriminatory tenant selection procedures in determining whether to admit a family referred by the PHA for occupancy of a

**Project-Based Voucher Program
HAP Contract for New Construction/Rehab**

Previous editions are obsolete

**HUD 52530A Page - 9 of Part 2
(04/2023)**

contract unit. The owner may refer families to the PHA for placement on the PBV waiting list.

4. The owner must promptly notify in writing any rejected applicant of the grounds for rejection.
5. The PHA must determine family eligibility in accordance with HUD requirements.
6. The contract unit leased to each family must be appropriate for the size of the family under the PHA's subsidy standards.
7. If a contract unit was occupied by an eligible family at the time the unit was selected by the PHA, or is so occupied on the effective date of the HAP contract, the owner must offer the family the opportunity to lease the same or another appropriately-sized contract unit with assistance under the HAP contract.
8. The owner is responsible for screening and selecting tenants from the families referred by the PHA from its waiting list.

b. Vacancies

1. The owner must promptly notify the PHA of any vacancy in a contract unit. After receiving the owner notice, the PHA shall make every reasonable effort to refer a sufficient number of families for owner to fill the vacancy..
2. The owner must rent vacant contract units to eligible families on the PHA waiting list referred by the PHA.
3. The PHA and the owner must make reasonable, good faith efforts to minimize the likelihood and length of any vacancy.
4. If any contract units have been vacant for a period of 120 or more days since owner notice of vacancy (and notwithstanding the reasonable good faith efforts of the PHA to fill such vacancies), the PHA may give notice to the owner amending the HAP contract to reduce the number of contract units by subtracting the number of contract units (by number of bedrooms) that have been vacant for such period.

10. TENANCY

a. Lease

The lease between the owner and each assisted family must be in accordance with HUD requirements. In all cases, the lease must include the HUD-required tenancy addendum. The tenancy addendum must include, word-for-word, all provisions required by HUD.

b. Termination of tenancy

1. The owner may only terminate the tenancy in accordance with the lease and HUD requirements.
2. The owner must give the PHA a copy of any owner eviction notice to the tenant at the same time that the owner gives notice to the tenant. Owner eviction notice means a notice to vacate, or a complaint or other initial pleading used to commence an eviction action under State or local law.

c. Family payment

1. The portion of the monthly rent to owner payable by the family (“tenant rent”) will be determined by the PHA in accordance with HUD requirements. The amount of the tenant rent is subject to change during the term of the HAP contract. Any changes in the amount of the tenant rent will be effective on the date stated in a notice by the PHA to the family and the owner.
2. The amount of the tenant rent as determined by the PHA is the maximum amount the owner may charge the family for rent of a contract unit, including all housing services, maintenance and utilities to be provided by the owner in accordance with the HAP contract and the lease.
3. The owner may not demand or accept any rent payment from the tenant in excess of the tenant rent as determined by the PHA. The owner must immediately return any excess rent payment to the tenant.
4. The family is not responsible for payment of the portion of the contract rent covered by the housing assistance payment under the HAP contract. The owner may not terminate the tenancy of an

assisted family for nonpayment of the PHA housing assistance payment.

5. The PHA is responsible only for making the housing assistance payments to the owner on behalf of the family in accordance with the HAP contract. The PHA is not responsible for paying the tenant rent, or any other claim by the owner.

d. Other owner charges

1. Except as provided in paragraph 2, the owner may not require the tenant or family members to pay charges for meals or supportive services. Nonpayment of such charges is not grounds for termination of tenancy.
2. In assisted living developments receiving project-based voucher assistance, owners may charge tenants, family members, or both for meals or supportive services. These charges may not be included in the rent to owner, nor may the value of meals and supportive services be included in the calculation of reasonable rent. Non-payment of such charges is grounds for termination of the lease by the owner in an assisted living development.
3. The owner may not charge the tenant or family members extra amounts for items customarily included in rent in the locality or provided at no additional cost to the unsubsidized tenant in the premises.

e. Security deposit

1. The owner may collect a security deposit from the family.
2. The owner must comply with HUD and PHA requirements, which may change from time to time, regarding security deposits from a tenant.
3. The PHA may prohibit security deposits in excess of private market practice, or in excess of amounts charged by the owner to unassisted families.
4. When the family moves out of the contract unit, the owner, subject to State and local law, may use the security deposit, including any interest on the deposit, in accordance with the lease, as reimbursement for any unpaid tenant rent, damages to the unit or

other amounts which the family owes under the lease. The owner must give the family a written list of all items charged against the security deposit and the amount of each item. After deducting the amount used as reimbursement to the owner, the owner must promptly refund the full amount of the balance to the family.

5. If the security deposit is not sufficient to cover amounts the family owes under the lease, the owner may seek to collect the balance from the family. However, the PHA has no liability or responsibility for payment of any amount owed by the family to the owner.

11. FAMILY RIGHT TO MOVE

- a. The family may terminate its lease at any time after the first year of occupancy. The family must give the owner advance written notice of intent to vacate (with a copy to the PHA) in accordance with the lease. If the family has elected to terminate the lease in this manner, the PHA must offer the family the opportunity for tenant-based rental assistance in accordance with HUD requirements.
- b. Before providing notice to terminate the lease under paragraph a, the family must first contact the PHA to request tenant-based rental assistance if the family wishes to move with continued assistance. If tenant-based rental assistance is not immediately available upon lease termination, the PHA shall give the family priority to receive the next available opportunity for tenant-based rental assistance.

12. OVERCROWDED, UNDER-OCCUPIED, AND ACCESSIBLE UNITS

The PHA subsidy standards determine the appropriate unit size for the family size and composition. The PHA and owner must comply with the requirements in 24 CFR 983.260. If the PHA determines that a family is occupying a wrong-size unit, or a unit with accessibility features that the family does not require, and the unit is needed by a family that requires the accessibility features, the PHA must promptly notify the family and the owner of this determination, and of the PHA's offer of continued assistance in another unit. 24 CFR 983.260(a).

13. PROHIBITION OF DISCRIMINATION

- a. The owner may not refuse to lease contract units to, or otherwise discriminate against any person or family in leasing of a contract unit, because of race, color, religion, sex (including sexual orientation and gender identity), national origin, disability, age or familial status.

- b. The owner must comply with the following requirements: The Fair Housing Act (42 U.S.C. 3601-19) and implementing regulations at 24 CFR part 100 *et seq.*; Executive Order 11063, as amended by Executive Order 12259 (3 CFR, 1959-1963 Comp., p. 652 and 3 CFR, 1980 Comp., p. 307) (Equal Opportunity in Housing Programs) and implementing regulations at 24 CFR part 107; title VI of the Civil Rights Act of 1964 (42 U.S.C. 2000d-2000d-4) (Nondiscrimination in Federally Assisted Programs) and implementing regulations at 24 CFR part 1; the Age Discrimination Act of 1975 (42 U.S.C. 6101-6107) and implementing regulations at 24 CFR part 146; section 504 of the Rehabilitation Act of 1973 (29 U.S.C. 794) and implementing regulations at 24 CFR part 8; title II of the Americans with Disabilities Act, 42 U.S.C. 12101 *et seq.*; 28 CFR part 35; Executive Order 11246, as amended by Executive Orders 11375, 11478, 12086, and 12107 (3 CFR, 1964-1965 Comp., p. 339; 3 CFR, 1966-1970 Comp., p. 684; 3 CFR, 1966-1970 Comp., p. 803; 3 CFR, 1978 Comp., p. 230; and 3 CFR, 1978 Comp., p. 264, respectively) (Equal Employment Opportunity Programs) and implementing regulations at 41 CFR chapter 60; Executive Order 11625, as amended by Executive Order 12007 (3 CFR, 1971-1975 Comp., p. 616 and 3 CFR, 1977 Comp., p. 139) (Minority Business Enterprises); Executive Order 12432 (3 CFR, 1983 Comp., p. 198) (Minority Business Enterprise Development); and Executive Order 12138, as amended by Executive Order 12608 (3 CFR, 1977 Comp., p. 393 and 3 CFR, 1987 Comp., p. 245) (Women's Business Enterprise).
- c. The owner must comply with HUD's Equal Access to HUD-assisted or -insured housing rule (24 CFR 5.105(a)(2)).
- d. The owner must comply with the Violence Against Women Act, as amended, and HUD's implementing regulation at 24 CFR part 5, Subpart L, and program regulations.
- e. The PHA and the owner must cooperate with HUD in the conducting of compliance reviews and complaint investigations pursuant to all applicable civil rights statutes, Executive Orders, and all related rules and regulations.

14. PHA DEFAULT AND HUD REMEDIES

If HUD determines that the PHA has failed to comply with the HAP contract, or has failed to take appropriate action to HUD's satisfaction or as directed by HUD, for enforcement of the PHA's rights under the HAP contract, HUD may assume

the PHA's rights and obligations under the HAP contract, and may perform the obligations and enforce the rights of the PHA under the HAP contract.

15. OWNER DEFAULT AND PHA REMEDIES

a. Owner default

Any of the following is a default by the owner under the HAP contract:

1. The owner has failed to comply with any obligation under the HAP contract, including the owner's obligations to maintain all contract units in accordance with the housing quality standards.
2. The owner has violated any obligation under any other housing assistance payments contract under Section 8 of the United States Housing Act of 1937 (42 U.S.C. 1437f).
3. The owner has committed any fraud or made any false statement to the PHA or HUD in connection with the HAP contract.
4. The owner has committed fraud, bribery or any other corrupt or criminal act in connection with any Federal housing assistance program.
5. If the property where the contract units are located is subject to a lien or security interest securing a HUD loan or a mortgage insured by HUD and:
 - i. The owner has failed to comply with the regulations for the applicable mortgage insurance or loan program, with the mortgage or mortgage note, or with the regulatory agreement; or
 - ii. The owner has committed fraud, bribery or any other corrupt or criminal act in connection with the HUD loan or HUD-insured mortgage.
6. The owner has engaged in any drug-related criminal activity or any violent criminal activity.

b. PHA remedies

1. If the PHA determines that a breach has occurred, the PHA may exercise any of its rights or remedies under the HAP contract.

2. The PHA must notify the owner in writing of such determination. The notice by the PHA to the owner may require the owner to take corrective action (as verified by the PHA) by a time prescribed in the notice.
3. The PHA's rights and remedies under the HAP contract include recovery of overpayments, termination or reduction of housing assistance payments, and termination of the HAP contract.

c. PHA remedy is not waived

The PHA's exercise or non-exercise of any remedy for owner breach of the HAP contract is not a waiver of the right to exercise that remedy or any other right or remedy at any time.

16. OWNER DUTY TO PROVIDE INFORMATION AND ACCESS REQUIRED BY HUD OR PHA

a. Required information

The owner must prepare and furnish any information pertinent to the HAP contract as may reasonably be required from time to time by the PHA or HUD. The owner shall furnish such information in the form and manner required by the PHA or HUD.

b. PHA and HUD access to premises

The owner must permit the PHA or HUD or any of their authorized representatives to have access to the premises during normal business hours and, for the purpose of audit and examination, to have access to any books, documents, papers and records of the owner to the extent necessary to determine compliance with the HAP contract, including the verification of information pertinent to the housing assistance payments or the HAP contract.

17. PHA AND OWNER RELATION TO THIRD PARTIES

a. Injury because of owner action or failure to act

The PHA has no responsibility for or liability to any person injured as a result of the owner's action or failure to act in connection with the implementation of the HAP contract, or as a result of any other action or failure to act by the owner.

b. Legal relationship

The owner is not the agent of the PHA. The HAP contract does not create or affect any relationship between the PHA and any lender to the owner or any suppliers, employees, contractors or subcontractors used by the owner in connection with the implementation of the HAP contract.

c. Exclusion of third-party claims

Nothing in the HAP contract shall be construed as creating any right of a family or other third party (other than HUD) to enforce any provision of the HAP contract, or to assert any claim against HUD, the PHA or the owner under the HAP contract.

d. Exclusion of owner claims against HUD

Nothing in the HAP contract shall be construed as creating any right of the owner to assert any claim against HUD.

18. PHA-OWNED UNITS

Notwithstanding Section 17 of this HAP contract, a PHA may own units assisted under the project-based voucher program, subject to the special requirements in 24 CFR 983.59 regarding PHA-owned units.

19. CONFLICT OF INTEREST

a. Interest of members, officers, or employees of PHA, members of local governing body, or other public officials

1. No present or former member or officer of the PHA (except tenant-commissioners), no employee of the PHA who formulates policy or influences decisions with respect to the housing choice voucher program or project-based voucher program, and no public official or member of a governing body or State or local legislator who exercises functions or responsibilities with respect to these programs, shall have any direct or indirect interest, during his or her tenure or for one year thereafter, in the HAP contract.
2. HUD may waive this provision for good cause.

b. Disclosure

The owner has disclosed to the PHA any interest that would be a violation of the HAP contract. The owner must fully and promptly update such

disclosures.

c. Interest of member of or delegate to Congress

No member of or delegate to the Congress of the United States of America or resident-commissioner shall be admitted to any share or part of this HAP Contract or to any benefits arising from the contract.

20. EXCLUSION FROM FEDERAL PROGRAMS

a. Federal requirements

The owner must comply with and is subject to requirements of 2 CFR part 2424.

b. Disclosure

The owner certifies that:

1. The owner has disclosed to the PHA the identity of the owner and any principal or interested party.
2. Neither the owner nor any principal or interested party is listed on the U.S. General Services Administration list of parties excluded from Federal procurement and nonprocurement programs; and none of such parties are debarred, suspended, subject to a limited denial of participation or otherwise excluded under 2 CFR part 2424.

21. TRANSFER OF THE CONTRACT OR PROPERTY

a. When consent is required

1. The owner agrees that neither the HAP contract nor the property may be transferred without the advance written consent of the PHA in accordance with HUD requirements.
2. "Transfer" includes:
 - a. Any sale or assignment or other transfer of ownership, in any form, of the HAP contract or the property;
 - b. The transfer of any right to receive housing assistance payments that may be payable pursuant to the HAP contract;

- c. The creation of a security interest in the HAP contract or the property;
 - d. Foreclosure or other execution on a security interest; or
 - e. A creditor's lien, or transfer in bankruptcy.
3. If the owner is a corporation, partnership, trust or joint venture, the owner is not required to obtain advance consent of the PHA pursuant to paragraph a for transfer of a passive and non-controlling interest in the ownership entity (such as a stock transfer or transfer of the interest of a limited partner), if any interests so transferred cumulatively represent less than half the beneficial interest in the HAP contract or the property. The owner must obtain advance consent pursuant to paragraph a for transfer of any interest of a general partner.

b. Transferee assumption of HAP contract

No transferee (including the holder of a security interest, the security holder's transferee or successor in interest, or the transferee upon exercise of a security interest) shall have any right to receive any payment of housing assistance payments pursuant to the HAP contract, or to exercise any rights or remedies under the HAP contract, unless the PHA has consented in advance, in writing to such transfer, and the transferee has agreed in writing, in a form acceptable to the PHA in accordance with HUD requirements, to assume the obligations of the owner under the HAP contract, and to comply with all the terms of the HAP contract.

c. Effect of consent to transfer

1. The creation or transfer of any security interest in the HAP contract is limited to amounts payable under the HAP contract in accordance with the terms of the HAP contract.
2. The PHA's consent to transfer of the HAP contract or the property does not change the terms of the HAP contract in any way, and does not change the rights or obligations of the PHA or the owner under the HAP contract.
3. The PHA's consent to transfer of the HAP contract or the property to any transferee does not constitute consent to any further transfers of the HAP contract or the property, including further transfers to any successors or assigns of an approved transferee.

d. When transfer is prohibited

The PHA will not consent to the transfer if any transferee, or any principal or interested party is debarred, suspended subject to a limited denial of participation, or otherwise excluded under 2 CFR part 2424, or is listed on the U.S. General Services Administration list of parties excluded from Federal procurement or nonprocurement programs.

22. SUBSIDY LAYERING

a. Owner disclosure

The owner must disclose to the PHA, in accordance with HUD requirements, information regarding any related assistance from the Federal Government, a State, or a unit of general local government, or any agency or instrumentality thereof, that is made available or is expected to be made available with respect to the contract units. Such related assistance includes, but is not limited to, any loan, grant, guarantee, insurance, payment, rebate, subsidy, credit, tax benefit, or any other form of direct or indirect assistance.

b. Limit of payments

Housing assistance payments under the HAP contract must be no more than is necessary, as determined in accordance with HUD requirements, to provide affordable housing after taking account of such related assistance. The PHA will adjust in accordance with HUD requirements the amount of the housing assistance payments to the owner to compensate in whole or in part for such related assistance.

23. OWNER LOBBYING CERTIFICATIONS

- a. The owner certifies, to the best of owner's knowledge and belief, that:
1. No Federally appropriated funds have been paid or will be paid, by or on behalf of the owner, to any person for influencing or attempting to influence an officer or employee of any agency, a Member of Congress, an officer or employee of Congress, or an employee of a Member of Congress in connection with the awarding of the HAP contract, or the extension, continuation, renewal, amendment, or modification of the HAP contract.
 2. If any funds other than Federally appropriated funds have been paid or will be paid to any person for influencing or attempting to

influence an officer or employee of any agency, a Member of Congress, an officer or employee of Congress, or an employee of a Member of Congress in connection with the HAP contract, the owner must complete and submit Standard Form-LLL, "Disclosure Form to Report Lobbying," in accordance with its instructions.

- b. This certification by the owner is a prerequisite for making or entering into this transaction imposed by 31 U.S.C. 1352.

24. TERMINATION OF HAP CONTRACT FOR WRONGFUL SELECTION OF CONTRACT UNITS

The HAP contract may be terminated upon at least 30 days notice to the owner by the PHA or HUD if the PHA or HUD determines that the contract units were not eligible for selection in conformity with HUD requirements.

25. NOTICES AND OWNER CERTIFICATIONS

- a. Where the owner is required to give any notice to the PHA pursuant to the HAP contract or any other provision of law, such notice must be in writing and must be given in the form and manner required by the PHA.
- b. Any certification or warranty by the owner pursuant to the HAP contract shall be deemed a material representation of fact upon which reliance was placed when this transaction was made or entered into.

26. NOTICE OF TERMINATION OR EXPIRATION WITHOUT EXTENSION

- a. An owner must provide notice to the PHA, and to the affected tenants, not less than 1 year prior to the termination or expiration without extension of a HAP contract.
- b. An owner who fails to provide such notice must permit tenants to remain in their units for the required notice period with no increase in the tenant portion of the rent. During this time period, an owner may not evict a tenant as a result of the owner's inability to collect an increased tenant portion of rent. With PHA agreement, an owner may extend the terminating contract for a period of time sufficient to give tenants 1 years's advance notice.

27. FAMILY'S RIGHT TO REMAIN

Upon termination or expiration of the contract without extension, each family assisted under the contract may elect to use its assistance to remain in the project

if the family's unit complies with the inspection requirements under section 8(o)(8) (42 U.S.C. 1437f(o)(8) of the U.S. Housing Act of 1937 ("the 1937 Act")), the rent for the unit is reasonable as required by section 8(o)(10)(A) of the 1937 Act, and the family pays its required share of the rent and the amount, if any, by which the unit rent (including the amount allowed for tenant-paid utilities) exceeds the applicable payment standard.

28. ENTIRE AGREEMENT; INTERPRETATION

- a. The HAP contract, including the exhibits, is the entire agreement between the PHA and the owner.
- b. The HAP contract must be interpreted and implemented in accordance with all statutory requirements, and with all HUD requirements, including amendments or changes in HUD requirements during the term of the HAP contract. The owner agrees to comply with all such laws and HUD requirements. Any regulatory citation specifically included in this HAP contract is subject to any subsequent revision of such citation.

**U.S. Department of Housing and Urban Development
Office of Public and Indian Housing**

SECTION 8 PROJECT-BASED VOUCHER PROGRAM

**AGREEMENT TO ENTER INTO A
HOUSING ASSISTANCE PAYMENTS CONTRACT**

NEW CONSTRUCTION OR REHABILITATION

PART II

OMB Burden Statement. The public reporting burden for this collection of information is estimated to average 0.25 hours, including the time for collecting, reviewing and reporting the data. This form is required to establish terms between a PHA and owner to provide housing assistance. Assurances of confidentiality are not provided under this collection. Send comments regarding this burden estimate or any other aspect of this collection of information, including suggestions to reduce this burden, to the Office of Public and Indian Housing, US. Department of Housing and Urban Development, Washington, DC 20410. HUD may not conduct and sponsor, and a person is not required to respond to, a collection of information unless the collection displays a valid control number.

2.1 Equal Employment Opportunity

- A. The owner shall incorporate or cause to be incorporated into any contract in excess of \$10,000 for construction work, or modification thereof, as defined in the regulations of the Secretary of Labor at 41 CFR chapter 60, which is to be performed pursuant to this Agreement, the following nondiscrimination clause:

During the performance of this contract, the contractor agrees as follows:

1. The contractor will not discriminate against any employee or applicant for employment because of race, color, creed, religion, sex, or national origin. The contractor will take affirmative action to ensure that applicants are employed, and that employees are treated during employment, without regard to their race, color, religion, creed, sex, or national origin. Such action shall include, but not be limited to, the following: employment, upgrading, demotion, or transfer; recruitment or recruitment advertising; layoffs or termination; rates of pay or other forms of compensation; and selection for training, including apprenticeship. The contractor agrees to post in conspicuous places, available to employees and applicants for employment, notices to be provided

by the contracting officer setting forth the provisions of this nondiscrimination clause.

2. The contractor will, in all solicitations or advertisements for employees placed by or on behalf of the contractor, state that all qualified applicants will receive consideration for employment without regard to race, color, religion, creed, sex, or national origin.
3. The contractor will send to each labor union or representative of workers with which the contractor has a collective bargaining agreement or other contract or understanding, a notice to be provided by or at the direction of the Government advising the labor union or workers representative of the contractor's commitments under this section and shall post copies of the notice in conspicuous places available to employees and applicants for employment.
4. The contractor will comply with all provisions of Executive Order No. 11246 of September 24, 1965, and with the rules, regulations, and relevant orders of the Secretary of Labor.
5. The contractor will furnish all information and reports required by Executive Order No. 11246 of September 24, 1965, and by the rules, regulations, and orders of the Secretary of Labor, or pursuant thereto, and will permit access to its books, records, and accounts by HUD and the Secretary of Labor for purposes of investigation to ascertain compliance with such rules, regulations and orders.
6. **In the event of the contractor's noncompliance with the nondiscrimination clauses of this contract or with any of the rules, regulations, or orders, the contract may be canceled, terminated, or suspended in whole or in part and the contractor may be declared ineligible for further contracts in accordance with procedures authorized in Executive Order No. 11246 of September 24, 1965, and such other sanctions as may be imposed and remedies invoked as provided in Executive Order No. 11246 of September 24, 1965, or by rule, regulation, or order of the Secretary of Labor or as otherwise provided by law.**
7. The contractor will include the provisions of paragraphs (1) through (7) in every subcontract or purchase order unless exempted by the rules, regulations, or orders of the Secretary of Labor issued pursuant to section 204 of Executive Order No. 11246 of September 24, 1965, so that such provisions will be binding upon each subcontractor or vendor. The contractor will take such action with respect to any subcontract or purchase order

as the Government may direct as a means of enforcing such provisions including sanctions for noncompliance; provided, however, that in the event a contractor becomes involved in, or is threatened with, litigation with a subcontractor or vendor as a result of such direction by the Government, the contractor may request the United States to enter into such litigation to protect the interest of the United States.

- B. The owner agrees to be bound by the above nondiscrimination clause with respect to his or her own employment practices when participating in federally assisted construction work.
- C. The owner agrees to assist and cooperate actively with HUD and the Secretary of Labor in obtaining the compliance of contractors and subcontractors with the nondiscrimination clause and the rules, regulations, and relevant orders of the Secretary of Labor, to furnish HUD and the Secretary of Labor such information as they may require for the supervision of such compliance, and to otherwise assist HUD in the discharge of HUD's primary responsibility for securing compliance.
- D. The owner further agrees to refrain from entering into any contract or contract modification subject to Executive Order No. 11246 of September 24, 1965, with a contractor debarred from, or who has not demonstrated eligibility for, Government contracts and federally assisted construction contracts pursuant to the Executive Order and will carry out such sanctions and penalties for violation of the nondiscrimination clause as may be imposed upon contractors and subcontractors by HUD or the Secretary of Labor pursuant to the Executive Order. In addition, if the owner fails or refuses to comply with these undertakings, HUD may take any or all of the following actions; cancel, terminate, or suspend in whole or in part this Agreement; refrain from extending any further assistance to the owner under the program with respect to which the failure or refusal occurred until satisfactory assurance of future compliance has been received from the owner, and refer the case to the Department of Justice for appropriate legal proceedings.

2.2 Reserved

2.3 HUD—Federal Labor Standards Provisions

The owner is responsible for inserting the entire text of section 2.3 of this Agreement in all construction contracts and, if the owner performs any rehabilitation work on the project, the owner must comply with all provisions of section 2.3. (Note: Sections 2.3(b) and (c) apply only when the amount of the prime contract exceeds \$100,000.)

(a)(1) Minimum Wages. (i) All laborers and mechanics employed or working upon the site of the work (or under the United States Housing Act of 1937 or under the Housing Act of 1949 in the construction or development of the project) will be paid unconditionally and not less often than once a week, and without subsequent deduction or rebate on any account (except such payroll deductions as are permitted by regulations issued by the Secretary of Labor under the Copeland Act (29 CFR part 3)), the full amount of wages and bona fide fringe benefits (or cash equivalents thereof) due at time of payment computed at rates not less than those contained in the wage determination of the Secretary of Labor which is attached hereto and made part hereof regardless of any contractual relationship which may be alleged to exist between the contractor and such laborers and mechanics. Contributions made or costs reasonably anticipated for bona fide fringe benefits under section 1(b)(2) of the Davis-Bacon Act on behalf of laborers or mechanics are considered wages paid to such laborers or mechanics, subject to the provisions of 29 CFR 5.5(a)(1)(iv); also, regular contributions made or costs incurred for more than a weekly period (but not less often than quarterly) under plans, funds, or programs, which cover the particular weekly period, are deemed to be constructively made or incurred during such weekly period.

*Such laborers and mechanics shall be paid the appropriate wage rate and fringe benefits on the wage determination for the classification of work actually performed, without regard to skill, except as provided in 29 CFR 5.5(a)(4). Laborers or mechanics performing work in more than one classification may be compensated at the rate specified for each classification for the time actually worked therein: **Provided, That the employer's payroll records accurately set forth the time spent in each classification in which work is performed. The wage determination (including any additional classification and wage rates conformed under 29 CFR 5.5(a)(1)(ii) and the Davis-Bacon poster (WH-1321)) shall be posted at all times by the contractor and its subcontractors at the site of the work in a prominent and accessible place where it can be easily seen by the workers.***

(ii)(A) Any class of laborers or mechanics, including helpers, which is not listed in the wage determination and which is to be employed under the contract shall be classified in conformance with the wage determination. HUD shall approve an additional classification and wage rate and fringe benefits therefore only when the following criteria have been met:

(1) The work to be performed by the classification requested is not performed by a classification in the wage determination;

(2) The classification is utilized in the area by the construction industry; and

(3) The proposed wage rate, including any bona fide fringe benefits, bears a reasonable relationship to the wage rates contained in the wage determination.

(B) If the contractor and the laborers and mechanics to be employed in the classification (if known), or their representatives, and HUD or its designee agree on the classification and wage rate (including the amount designated for fringe benefits where appropriate), a report of the action taken shall be sent by HUD or its designee to the Administrator of the Wage and Hour Division, U.S. Department of Labor, Washington, D. C. 20210. The Administrator, or an authorized representative, will approve, modify, or disapprove every additional classification action within 30 days of receipt and so advise HUD or its designee or will notify HUD or its designee within the 30-day period that additional time is necessary.

(C) In the event the contractor, the laborers or mechanics to be employed in the classification or their representatives, and HUD or its designee do not agree on the proposed classification and wage rate (including the amount designated for fringe benefits, where appropriate), HUD or its designee shall refer the questions, including the views of all interested parties and the recommendation of HUD or its designee, to the Administrator for determination. The Administrator, or an authorized representative, will issue a determination within 30 days of receipt and so advise HUD or its designee or will notify HUD or its designee within the 30-day period that additional time is necessary.

(D) The wage rate (including fringe benefits where appropriate) determined pursuant to subparagraphs (1)(B) or (C) of this paragraph, shall be paid to all workers performing work in the classification under this contract from the first day on which work is performed in the classification.

(iii) Whenever the minimum wage rate prescribed in the contract for a class of laborers or mechanics includes a fringe benefit which is not expressed as an hourly rate, the contractor shall either pay the benefit as stated in the wage determinations or shall pay another bona fide fringe benefit or an hourly cash equivalent thereof.

(iv) If the contractor does not make payments to a trustee or other third person, the contractor may consider as part of the wages of any laborer or mechanic the amount of any costs reasonably anticipated in providing bona fide fringe benefits under a plan or program: Provided, That the Secretary of Labor has found, upon the written request of the contractor, that the applicable standards of the Davis-Bacon Act have been met. The Secretary of Labor may require the contractor to set aside in a separate account assets for the meeting of obligations under the plan or program.

(2) Withholding. HUD or its designee shall upon its own action or upon written request of an authorized representative of the Department of Labor withhold or cause to be withheld from the contractors under this contract or any other Federal contract with the same prime contractor, or any other Federally-assisted contract subject to Davis-Bacon prevailing wage requirements, which is held by the same prime contractor so much of the accrued payments or advances as may be considered necessary to pay laborers and mechanics, including apprentices, trainees and helpers, employed by the contractor or any subcontractor the full amount of wages required by the contract. In the event of failure to pay any laborer or mechanic, including any apprentice, trainee or helper, employed or working on the site of the work (or under the United States Housing Act of 1937 or under the Housing Act of 1949 in the construction or development of the project), all or part of the wages required by the contract, HUD or its designee may, after written notice to the contractor, sponsor, applicant, or owner, take such action as may be necessary to cause the suspension of any further payment, advance, or guarantee of funds until such violations have ceased. HUD or its designee may, after written notice to the contractor, disburse such amounts withheld for and on account of the contractor or subcontractor to the respective employees to whom they are due.

(3)(i) Payrolls and Basic Records. Payrolls and basic records relating thereto shall be maintained by the contractor during the course of the work and preserved for a period of three years thereafter for all laborers and mechanics working at the site of the work (or under the United States Housing Act of 1937, or under the Housing Act of 1949, in the construction or development of the project). Such records shall contain the name, address, and social security number of each such worker, his or her correct classification, hourly rates of wages paid (including rates of contributions or costs anticipated for bona fide fringe benefits or cash equivalents thereof of the types described in section 1(b)(2)(B) of the Davis-Bacon Act), daily and weekly number of hours worked, deductions made and actual wages paid. Whenever the

Secretary of Labor has found under 29 CFR 5.5 (a)(1)(iv) that the wages of any laborer or mechanic include the amount of any costs reasonably anticipated in providing benefits under a plan or program described in section 1(b)(2)(B) of the Davis-Bacon Act, the contractor shall maintain records which show that the commitment to provide such benefits is enforceable, that the plan or program is financially responsible, and that the plan or program has been communicated in writing to the laborers or mechanics affected, and records which show the costs anticipated or the actual cost incurred in providing such benefits. Contractors employing apprentices or trainees under approved programs shall maintain written evidence of the registration of apprenticeship programs and certification of trainee programs, the registration of the apprentices and trainees, and the ratios and wage rates prescribed in the applicable programs.

(ii)(A) The contractor shall submit weekly for each week in which any contract work is performed a copy of all payrolls to HUD the PHA. The payrolls submitted shall set out accurately and completely all of the information required to be maintained under 29 CFR 5.5(a)(3)(i), except that full social security numbers and home addresses shall not be included in weekly transmittals. Instead the payrolls shall only need to include an individually identifying number for each employee (e.g. the last four digits of the employee's social security number). The required weekly payroll information may be submitted in any form desired. Optional Form WH-347 is available for this purpose from the Wage and Hour Division Web site at: <http://www.dol.gov/esa/whd/forms/wh347instr.htm> or its successor site. The prime contractor is responsible for the submission of copies of payrolls by all subcontractors. Contractors and subcontractors shall maintain the full social security number and current address of each covered worker, and shall provide them upon request to HUD or its designee if the agency is a party to the contract, but if the agency is not such a party, the contractor will submit them to the applicant, sponsor, or owner, as the case may be, for transmission to HUD, the contractor, or the Wage and Hour Division of the Department of Labor for purposes of an investigation or audit of compliance with prevailing wage requirements. It is not a violation of this section for a prime contractor to require a subcontractor to provide addresses and social security numbers to the prime contractor for its own records, without weekly submission to the sponsoring government agency (or the applicant, sponsor, or owner).

(B) Each payroll submitted shall be accompanied by a "Statement of Compliance," signed by the contractor or subcontractor or his

or her agent who pays or supervises the payment of the persons employed under the contract and shall certify the following:

(1) That the payroll for the payroll period contains the information required to be provided under 29 CFR 5.5(a)(3)(ii), the appropriate information is being maintained under 29 CFR 5.5(a)(3)(i) and that such information is correct and complete;

(2) That each laborer or mechanic (including each helper, apprentice, and trainee) employed on the contract during the payroll period has been paid the full weekly wages earned, without rebate, either directly or indirectly, and that no deductions have been made either directly or indirectly from the full wages earned, other than permissible deductions as set forth in 29 CFR part 3;

(3) That each laborer or mechanic has been paid not less than the applicable wage rates and fringe benefits or cash equivalents for the classification of work performed, as specified in the applicable wage determination incorporated into the contract.

(C) The weekly submission of a properly executed certification set forth on the reverse side of Optional Form WH-347 shall satisfy the requirement for submission of the "Statement of Compliance" required by paragraph (a)(3)(ii)(B) of this section.

(D) The falsification of any of the above certifications may subject the contractor or subcontractor to civil or criminal prosecution under section 1001 of Title 18 and section 231 of Title 31 of the United States Code.

(iii) The contractor or subcontractor shall make the records required under paragraph (a)(3)(i) of this section available for inspection, copying, or transcription by authorized representatives of HUD or its designee or the Department of Labor, and shall permit such representatives to interview employees during working hours on the job. If the contractor or subcontractor fails to submit the required records or to make them available, HUD or its designee may, after written notice to the contractor, sponsor, applicant, or owner, take such action as may be necessary to cause the suspension of any further payment, advance, or guarantee of funds. Furthermore, failure to submit the required records upon request or to make such records available may be grounds for debarment action pursuant to 29 CFR 5.12.

(4) Apprentices and Trainees. (i) Apprentices. Apprentices will be permitted to work at less than the predetermined rate for the work they performed when they are employed pursuant to and

individually registered in a bona fide apprenticeship program registered with the U.S. Department of Labor, Employment and Training Administration, Office of Apprenticeship Training, Employer and Labor Services, or with a State Apprenticeship Agency recognized by the Office, or if a person is employed in his or her first 90 days of probationary employment as an apprentice in such an apprenticeship program, who is not individually registered in the program, but who has been certified by the Office of Apprenticeship Training, Employer and Labor Services, or a State Apprenticeship Agency (where appropriate) to be eligible for probationary employment as an apprentice. The allowable ratio of apprentices to journeymen on the job site in any craft classification shall not be greater than the ratio permitted to the contractor as to the entire work force under the registered program. Any worker listed on a payroll at an apprentice wage rate, who is not registered or otherwise employed as stated above, shall be paid not less than the applicable wage rate on the wage determination for the classification of work actually performed. In addition, any apprentice performing work on the job site in excess of the ratio permitted under the registered program shall be paid not less than the applicable wage rate on the wage determination for the work actually performed. Where a contractor is performing construction on a project in a locality other than that in which its program is registered, the ratios and wage rates (expressed in percentages of the journeyman's hourly rate) specified in the contractor's or subcontractor's registered program shall be observed. Every apprentice must be paid at not less than the rate specified in the registered program for the apprentice's level of progress, expressed as a percentage of the journeymen hourly rate specified in the applicable wage determination. Apprentices shall be paid fringe benefits in accordance with the provisions of the apprenticeship program. If the apprenticeship program does not specify fringe benefits, apprentices must be paid the full amount of fringe benefits listed on the wage determination for the applicable classification. If the Administrator determines that a different practice prevails for the applicable apprentice classification, fringes shall be paid in accordance with that determination. In the event the Office of Apprenticeship Training, Employee and Labor Services, or a State Apprenticeship Agency recognized by the Office, withdraws approval of an apprenticeship program, the contractor will no longer be permitted to utilize apprentices at less than the applicable predetermined rate for the work performed until an acceptable program is approved.

(ii) Trainees. Except as provided in 29 CFR 5.16, trainees will not be permitted to work at less than the predetermined rate for the work performed unless they are employed pursuant to and

individually registered in a program which has received prior approval, evidenced by formal certification by the U.S. Department of Labor, Employment and Training Administration. The ratio of trainees to journeymen on the job site shall not be greater than permitted under the plan approved by the Employment and Training Administration. Every trainee must be paid at not less than the rate specified in the approved program for the trainee's level of progress, expressed as a percentage of the journeyman hourly rate specified in the applicable wage determination. Trainees shall be paid fringe benefits in accordance with the provisions of the trainee program. If the trainee program does not mention fringe benefits, trainees shall be paid the full amount of fringe benefits listed on the wage determination unless the Administrator of the Wage and Hour Division determines that there is an apprenticeship program associated with the corresponding journeyman wage rate on the wage determination which provides for less than full fringe benefits for apprentices. Any employee listed on the payroll at a trainee rate who is not registered and participating in a training plan approved by the Employment and Training Administration shall be paid not less than the applicable wage rate on the wage determination for the classification of work actually performed. In addition, any trainee performing work on the job site in excess of the ratio permitted under the registered program shall be paid not less than the applicable wage rate on the wage determination for the work actually performed. In the event the Employment and Training Administration withdraws approval of a training program, the contractor will no longer be permitted to utilize trainees at less than the applicable predetermined rate for the work performed until an acceptable program is approved.

(iii) Equal Employment Opportunity. The utilization of apprentices, trainees and journeymen under this part shall be in conformity with the equal employment opportunity requirements of Executive Order 11246, as amended, and 29 CFR part 30.

(5) Compliance with Copeland Act Requirements. The contractor shall comply with the requirements of 29 CFR part 3 which are incorporated by reference in this Agreement.

(6) Subcontracts. The contractor or subcontractor will insert in any subcontracts the clauses contained in section 2.3(a)(1) through (11) and such other clauses as HUD or its designee may by appropriate instructions require, and also a clause requiring the subcontractors to include these clauses in any lower tier subcontracts. The prime contractor shall be responsible for the

compliance by any subcontractor or lower tier subcontractor with all the contract clauses in this section 2.3(a).

(7) Contract Terminations; Debarment. A breach of the contract clauses in 29 CFR 5.5 may be grounds for termination of the contract, and for debarment as a contractor and a subcontractor as provided in 29 CFR 5.12.

(8) Compliance with Davis-Bacon and Related Act Requirements. All rulings and interpretations of the Davis-Bacon and related Acts contained in 29 CFR parts 1, 3, and 5 are herein incorporated by reference in this contract.

(9) Disputes Concerning Labor Standards. Disputes arising out of the labor standards provisions of this contract shall not be subject to the general disputes clause of this contract. Such disputes shall be resolved in accordance with the procedures of the Department of Labor set forth in 29 CFR parts 5, 6, and 7. Disputes within the meaning of this clause include disputes between the contractor (or any of its subcontractors) and the PHA, HUD, the U. S. Department of Labor, or the employees or their representatives.

(10) Certification of Eligibility. (i) By entering into this Agreement, the contractor certifies that neither it (nor he or she) nor any person or firm who has an interest in the contractor's firm is a person or firm ineligible to be awarded Government contracts by virtue of section 3(a) of the Davis-Bacon Act or 29 CFR 5.12(a)(1) or to be awarded HUD contracts or participate in HUD programs pursuant to 24 CFR part 24.

(ii) No part of this Agreement shall be subcontracted to any person or firm ineligible for award of a Government contract by virtue of section 3(a) of the Davis-Bacon Act or 29 CFR 5.12(a)(1) or to be awarded HUD contracts or participate in HUD programs pursuant to 24 CFR part 24.

(iii) The penalty for making false statements is prescribed in the U.S. Criminal Code, 18 U.S.C. 1001. Additionally, U.S. Criminal Code, section 1010, Title 18, U.S.C., "Federal Housing Administration transactions, provides in part: "Whoever, for the purpose of ...influencing in any way the action of such Administration...makes, utters or publishes any statement, knowing the same to be false... shall be fined not more than \$5,000 or imprisoned not more than two years, or both."

11. Complaints, Proceedings, or Testimony by Employees. No laborer or mechanic to whom the wage, salary, or other labor

standards provisions of this Agreement are applicable shall be discharged or in any other manner discriminated against by the Contractor or any subcontractor because such employee has filed any complaint or instituted or caused to be instituted any proceeding or has testified or is about to testify in any proceeding under or relating to the labor standards applicable under this Agreement to his employer.

(b) Contract Work Hours and Safety Standards Act. The provisions of this paragraph (b) are applicable only where the amount of the prime contract exceeds \$100,000. As used in this paragraph, the terms "laborers" and "mechanics" include watchmen and guards.

(1) Overtime Requirements. No contractor or subcontractor contracting for any part of the contract work which may require or involve the employment of laborers or mechanics shall require or permit any such laborer or mechanic in any workweek in which he or she is employed on such work to work in excess of forty hours in such workweek unless such laborer or mechanic receives compensation at a rate not less than one and one-half times the basic rate of pay for all hours worked in excess of forty hours in such workweek.

(2) Violation; Liability for Unpaid Wages; Liquidated Damages. In the event of any violation of the clause set forth in subparagraph (1) of this paragraph, the contractor and any subcontractor responsible therefore shall be liable for the unpaid wages. In addition, such contractor and subcontractor shall be liable to the United States (in the case of work done under contract for the District of Columbia or a territory, to such District or to such territory), for liquidated damages. Such liquidated damages shall be computed with respect to each individual laborer or mechanic, including watchmen and guards, employed in violation of the clause set forth in subparagraph (1) of this paragraph, in the sum of \$25 for each calendar day on which such individual was required or permitted to work in excess of the standard workweek of forty hours without payment of the overtime wages required by the clause set forth in subparagraph (1) of this paragraph.

(3) Withholding for Unpaid Wages and Liquidated Damages. HUD or its designee shall upon its own action or upon written request of an authorized representative of the Department of Labor withhold or cause to be withheld, from any monies payable on account of work performed by the contractor or subcontractor under any such contract or any other Federal contract with the same prime contractor, or any other Federally-assisted contract subject to the Contract Work Hours and Safety Standards Act, which is held by

the same prime contractor such sums as may be determined to be necessary to satisfy any liabilities of such contractor or subcontractor for unpaid wages and liquidated damages as provided in the clause set forth in subparagraph (2) of this paragraph.

(4) Subcontractors. The contractor or subcontractor shall insert in any subcontracts the clauses set forth in subparagraph (1) through (4) of this paragraph and also a clause requiring the subcontractors to include these clauses in any lower tier subcontracts. The prime contractor shall be responsible for compliance by any subcontractor or lower tier subcontractor with the clauses set forth in subparagraphs (1) through (4) of this paragraph.

(c) Health and Safety. The provisions of this paragraph (c) are applicable only where the amount of the prime contract exceeds \$100,000.

(1) No laborer or mechanic shall be required to work in surroundings or under working conditions which are unsanitary, hazardous or dangerous to his health and safety as established under construction safety and health standards promulgated by the Secretary of Labor by regulation.

(2) The contractor shall comply with all regulations issue by the Secretary of Labor pursuant to Title 29 part 1926 and failure to comply may result in imposition of sanctions pursuant to the Contract Work Hours and Safety Standards Act, 40 USC 3701 et seq.

(3) The contractor shall include the provisions of this paragraph in every subcontract so that such provisions will be binding on each subcontractor. The contractor shall take such action with respect to any subcontract as the Secretary of Housing and Urban Development or the Secretary of Labor shall direct as a means of enforcing such provisions.

2.4 Reserved

2.5 Reserved

2.6 Reserved

2.7 Wage and Claims Adjustments

The owner shall be responsible for the correction of all violations under section 2.3, including violations committed by other contractors. In cases where there is evidence of underpayment of salaries or wages to any laborers or mechanics (including apprentices and trainees) by the owner or other contractor or a failure by the owner or other contractor to submit payrolls and related reports, the owner shall be required to place an amount in escrow, as determined by HUD sufficient to pay persons employed on the work covered by the Agreement the difference between the salaries or wages actually paid such employees for the total number of hours worked and the full amount of wages required under this Agreement, as well as an amount determined by HUD to be sufficient to satisfy any liability of the owner or other contractor for liquidated damages pursuant to section 2.3. The amounts withheld may be disbursed by HUD for and on account of the owner or other contractor to the respective employees to whom they are due, and to the Federal Government in satisfaction of liquidated damages under section 2.3.

2.8 Reserved

2.9 Evidence of Unit(s) Completion; Escrow

- A. The owner shall evidence the completion of the unit(s) by furnishing the PHA, in addition to the requirements listed in Part I of this Agreement, a certification of compliance with the provisions of sections 2.3 and 2.7 of this Agreement, and that to the best of the owner's knowledge and belief there are no claims of underpayment to laborers or mechanics in alleged violation of these provisions of the Agreement. In the event there are any such pending claims to the knowledge of the owner, the PHA, or HUD, the owner will place a sufficient amount in escrow, as directed by the PHA or HUD, to assure such payments.
- B. The escrows required under this section and section 2.7 of shall be paid to HUD, as escrowee, or to an escrowee designated by HUD, and the conditions and manner of releasing such escrows shall be designated and approved by HUD.

2.10 Flood Insurance

If the project is located in an area that has been identified by the Federal Emergency Management Agency as an area having special flood hazards and if

the sale of flood insurance has been made available under the National Flood Insurance Program, the owner agrees that: (1) the project will be covered, during the life of the property, by flood insurance in an amount at least equal to its development or project cost (less estimated land cost) or to the limit of coverage made available with respect to the particular type of property under the National Flood Insurance Act of 1968, whichever is less; and (2) that it will advise any prospective purchaser or transferee of the property in writing of the continuing statutory requirement to maintain such flood insurance during the life of the property.

**U.S. Department of Housing and Urban Development (HUD) Project-based
Section 8 Contract Administration**

**CONSENT TO ASSIGNMENT OF
AHAP AND HAP CONTRACT
AS SECURITY FOR FINANCING (PBV)**

OMB Control #2577-0169

"Public reporting burden for this collection of information is estimated to average 1 hour. This includes the time for collecting, reviewing and reporting the data. The information is being collected for obtaining a signature on legal binding documents and will be used to enforce contractual obligations. Response to this request for information is required in order to receive the benefits to be derived. This agency may not collect this information, and you are not required to complete this form unless it displays a currently valid OMB control number. No confidentiality is assured."

Privacy Act Notice: The United States Department of Housing and Urban Development, Federal Housing Administration, is authorized to solicit the information requested in the form by virtue of Title 12, United States Code, Section 1701 et seq., and regulations promulgated thereunder at Title 12, Code of Federal Regulations. While no assurance of confidentiality is pledged to respondents, HUD generally discloses this data only in response to a Freedom of Information Act request.

I. IDENTIFICATION OF ACC AND HAP CONTRACT

Annual Contributions Contract Number: _____

Section 8 HAP Contract Number: _____

Project Name: Crossings at Palm Desert

Project Location: Dick Kelly Drive and Gateway Avenue
Palm Desert, California 92211

Assessor's Parcel Number 694-130-017, 694-
130-018, 694-130-019 and 694-130-020

II. NAMES

Contract Administrator (PHA): Housing Authority of the County of Riverside

Contract Administrator (PHA) address:

Housing Authority of the County of Riverside
5555 Arlington Avenue
Riverside, California 92504-2506

Owner: A0358 Monterey, L.P.

Owner address:

Urban Housing Communities
2000 East Fourth Street, Suite 205
Santa Ana, California 92705

Lender: Citibank, N.A.

Lender address:

388 Greenwich Street, Trading 4th Floor
New York, New York 10013
Attention: Transaction and Asset Management Group
Deal ID: 50009621

II. DEFINITIONS

ACC. Annual Contributions Contract.

AHAP CONTRACT. The Agreement to Enter Into Housing Assistance Payments Contract (the "AHAP") for the project pursuant to which PHA agrees to enter into a HAP Contract pursuant to the terms and conditions set forth therein.

ASSIGNMENT AS SECURITY. The creation of a security interest in the owner's interest pursuant to the AHAP Contract and HAP Contract, and a transfer of such security interest to an assignee secured party.

CONTRACT ADMINISTRATOR. HUD or a PHA acting as contract administrator under an ACC with HUD.

FULL ASSIGNMENT. An assignment of the AHAP Contract or the HAP Contract other than an assignment as security. "Full Assignment" includes a sale, conveyance or other transfer of the AHAP Contract or the HAP Contract, voluntary or involuntary, to a successor in interest.

HAP CONTRACT. The Housing Assistance Payments Contract for units in the project. The HAP Contract shall be entered between the owner and the contract administrator pursuant to Section 8 of the United States Housing Act of 1937 (42 U.S.C. 1437f) and the terms and conditions set forth in the AHAP Contract.

PHA. Public Housing Agency.

PROJECT. The project identified in section I of the consent to assignment.

SECURED PARTY. A party that holds a security interest in the owner's interest pursuant to the AHAP Contract or the HAP Contract, including the lender, and assignees of the lender's security interest.

SUCCESSOR. The term "successor" includes an assignee.

IV. BACKGROUND

Pursuant to the terms of the AHAP Contract, neither the AHAP nor the HAP Contract (including any interest in the HAP Contract or any payments under the HAP Contract) may be assigned without the prior written consent of the contract administrator.

The owner has advised the contract administrator that the owner wants to grant the lender a security interest in the AHAP Contract and the HAP Contract, as security for a loan by the lender to the owner with respect to the project.

V. CONSENT TO ASSIGNMENT AS SECURITY

By execution of this consent to assignment as security, the contract administrator consents to the assignment as security of the AHAP Contract and the HAP Contract, once executed, by the owner to the lender as security for a loan by the lender to the owner with respect to the project.

The contract administrator consents to transfer of the lender's security interest to successor secured parties.

VI. EFFECT OF CONSENT TO ASSIGNMENT

The contract administrator is not a party to the loan or the loan documents, nor to any assignment of the AHAP Contract or the HAP Contract by the owner to the lender as security for the loan, nor to any transfer of the AHAP Contract or the HAP Contract or the loan by the lender. Issuance of the consent to assignment does not signify that HUD or the contract administrator has reviewed, approved or agreed to the terms of any financing or refinancing; to any term of the loan documents; or to the terms of any assignment of the AHAP Contract or the HAP Contract by the owner to the lender as security for the loan, or by the lender to any transferee of the loan.

The consent to assignment of the AHAP Contract and the HAP Contract as security for the loan does not change the terms of the AHAP Contract in any way, and does not change the rights or obligations of HUD, the contract administrator or the owner under the AHAP Contract and the HAP Contract.

VII. EXERCISE OF SECURITY INTEREST – ASSIGNEE ASSUMPTION OF HAP CONTRACT OBLIGATIONS

Notwithstanding the contract administrator's grant of consent to assignment by the owner of a security interest in the AHAP Contract and the HAP Contract to the lender as security for the loan, and to further transfer of such security interest to successor secured parties, the contract administrator's execution of this consent does not constitute consent to a full assignment of the AHAP contract to any entity, including the lender or any successor secured party.

A secured party may not exercise any rights or remedies against the contract administrator or HUD under the AHAP Contract or the HAP Contract, and shall not have any right to receive housing assistance payments that may be payable to the owner under the HAP Contract, until and unless:

- The contract administrator has approved the secured party as successor to the owner pursuant to the AHAP contract, and
- The secured party seeking to exercise such rights or remedies, or to receive such payments, has executed and delivered, in a form acceptable to the contract administrator in accordance with HUD requirements, an agreement by the assignee to comply with all the terms of the AHAP Contract and the HAP Contract, and to assume all obligations of the owner under the AHAP Contract and the HAP Contract.

VIII. PAYMENT TO SECURED PARTY

When a secured party notifies the contract administrator, in writing, that housing assistance payments payable pursuant to the HAP Contract

should be directed to the secured party (in accordance with paragraph VII above), the contract administrator may make such payments to the secured party instead of the owner. In making such payments, the contract administrator is not required to consider or make any inquiry as to the existence of a default under the loan documents, but may rely on notice by the secured party; and any payments by the contract administrator to the secured party shall be credited against amounts payable by the contract administrator to the owner pursuant to the HAP Contract.

IX. WHEN ASSIGNMENT IS PROHIBITED

The consent to assignment as security shall be void ab initio if HUD determines that any assignee, or any principal or interested party of the assignee, is debarred, suspended or subject to a limited denial of participation under 24 CFR part 24, or is listed on the U.S. General Services Administration list of parties excluded from Federal procurement or non-procurement programs.

CONTRACT ADMINISTRATOR (PHA)

Name of Contract Administrator (Print)

Housing Authority of the County of Riverside

By: _____

Signature of authorized representative

Heidi Marshall, Executive Director

Name and official title (Print)

Date _____

FORM APPROVED COUNTY COUNSEL

BY: APD

AMRIT P. DHILLON

9/15/2023

DATE

OWNER AGREEMENT TO ASSIGNMENT AS SECURITY

The owner has read the terms of the contract administrator's consent to assignment by the owner of a security interest in the AHAP Contract and the HAP Contract to the lender as security for the loan, and to further transfer of such security interest to successor secured parties. In consideration for the contract administrator's grant of such consent to assignment, the owner agrees to all the terms of the consent to assignment, and agrees that any assignment by the owner is subject to all such terms.

OWNER

A0358 Monterey, L.P.
A California limited partnership

By: A0358 Monterey Admin Holdings LLC
A California limited liability company

Its: Administrative General Partner

By: John F. Bigley
Its: Manager

By: A0358 Monterey Holdings LLC
A California limited liability company

Its: Managing General Partner

By: John F. Bigley
Its: Manager

Date: _____