

SUBMITTAL TO THE BOARD OF SUPERVISORS
COUNTY OF RIVERSIDE, STATE OF CALIFORNIA



ITEM: 3.21
(ID # 22863)

MEETING DATE:
Tuesday, January 09, 2024

FROM : FACILITIES MANAGEMENT AND RIVERSIDE UNIVERSITY HEALTH SYSTEM :

SUBJECT: FACILITIES MANAGEMENT (FM) AND RIVERSIDE UNIVERSITY HEALTH SYSTEM: Riverside University Health System Medical Center Kitchen Dishwasher Equipment and Flooring Replacement Project - Approval of Revised Project Budget, Ratify and Approve Change Order No. 1 and Approve Notice of Completion for Horizons Construction Company International, Inc.; District 5. [\$84,508 - 100% RUHS Enterprise Fund 40050] (Clerk to Record Notice of Completion) (4/5 Vote Required)

RECOMMENDED MOTION: That the Board of Supervisors:

1. Approve an increase to the project budget in the not to exceed amount of \$84,508 for a revised project budget of \$482,412 for the Riverside University Health System Medical Center Kitchen Dishwasher Equipment and Flooring Replacement (RUHS-MC Kitchen Dishwasher and Flooring Replacement) Project located at 26520 Cactus Avenue in Moreno Valley, California;

Continued on Page 2

ACTION:Policy, CIP, 4/5 Vote Required

Jennifer Cruikshank, Chief Executive Officer - Health System

12/13/2023

Rose Salgado, Director of Facilities Management

12/13/2023

MINUTES OF THE BOARD OF SUPERVISORS

On motion of Supervisor Perez, seconded by Supervisor Jeffries and duly carried by unanimous vote, IT WAS ORDERED that the above matter is approved as recommended.

Ayes: Jeffries, Spiegel, Washington, Perez and Gutierrez
Nays: None
Absent: None
Date: January 9, 2024
xc: FM, RUHS, Recorder

Kimberly A. Rector
Clerk of the Board

By: 
Deputy

**SUBMITTAL TO THE BOARD OF SUPERVISORS COUNTY OF RIVERSIDE,
STATE OF CALIFORNIA**

RECOMMENDED MOTION: That the Board of Supervisors:

2. Authorize the use of RUHS Enterprise Fund 40050 in the not to exceed additional amount of \$84,508 for the Project, including reimbursement to Facilities Management (FM) for incurred project related expenses;
3. Ratify and Approve Change Order No. 1 for Horizons Construction Company International, Inc. (Horizons) of Orange, California, in the amount of \$137,998 to account for additional costs and work which were required to expedite work; find that the work was integral to the Project and that competitive bidding would not produce an advantage and is impractical for the work;
4. Authorize the Chairman of the Board (Chairman) to execute Change Order No. 1 for Horizons on behalf of the County;
5. Accept the RUHS-MC Kitchen Dishwasher and Flooring Replacement Project constructed by Horizons as complete and authorize the Chairman to execute the Notice of Completion;
6. Direct the Clerk of the Board to record the attached Notice of Completion; and
7. Authorize the release of undisputed retained funds in the amount of \$14,659 to Horizons in accordance with the contract terms and applicable law, per the General Conditions of the contract.

FINANCIAL DATA	Current Fiscal Year:	Next Fiscal Year:	Total Cost:	Ongoing Cost
COST	\$ 84,508	\$ 0	\$ 84,508	\$ 0
NET COUNTY COST	\$ 0	\$ 0	\$ 0	\$ 0
SOURCE OF FUNDS: RUHS Enterprise Fund 40050 – 100%			Budget Adjustment: No	
			For Fiscal Year: 23/24	

C.E.O. RECOMMENDATION: Approve

BACKGROUND:

Summary

On November 2, 2021, Item 3.11, the Board of Supervisors (Board) approved in-principle, a preliminary project budget in the amount of \$397,904 and the Construction Contract with Horizons in the amount of \$155,176 for the RUHS-MC Kitchen Dishwasher and Flooring Replacement Project located in Moreno Valley, CA 92555. The scope of work to the Project was

**SUBMITTAL TO THE BOARD OF SUPERVISORS COUNTY OF RIVERSIDE,
STATE OF CALIFORNIA**

to replace the dishwasher equipment and flooring in the kitchen due to water damage caused by a water leak in the ceiling of the kitchen.

During construction, one change order was required for additional plumbing relocation, additional fire sprinklers and alarm, and an upgraded dishwasher system. Bidding of this work would have been impractical to expediently perform the work required. Change Order No. 1 exceeds the 10% contingency allowance; therefore, Facilities Management (FM) is seeking Board approval to compensate Horizons in the not to exceed amount of \$137,998, for a new contract value of \$293,174.

Horizons has completed the work and the Project has been inspected and found to comply with the contract and safety requirements. This Board action will release the undisputed contract retention funds in the amount of \$14,659 to Horizons after the Notice of Completion has been recorded and the 35-day lien period has expired, per the contract terms and applicable law.

Facilities Management is requesting the Board approve a project budget increase of \$84,508, from \$397,904 to \$482,412 to complete the construction portion and cover other remaining project related obligations to successfully complete the Project.

Impact on Residents and Businesses

The RUHS-MC Kitchen Dishwasher and Flooring Replacement Project will help to ensure the health and sanitation of food preparation in the Medical Center for the patients and staff.

Additional Fiscal Information

The approximate allocation of the project budget adjustment is as follows:

BUDGET LINE ITEMS	BUDGET AMOUNT	PROJECT BUDGET ADJUSTMENT	REVISED PROJECT BUDGET
DESIGN PROFESSIONAL OF RECORD	37,845	21,738	59,583
SPECIALTY CONSULTANTS	23,000	(23,000)	0
REGULATORY PERMITTING	11,100	(6,800)	4,300
CONSTRUCTION CONTRACT	155,176	137,998	293,174
CONSTRUCTION OTHER	111,390	(27,255)	84,135
COUNTY ADMINISTRATION	23,220	18,000	41,220
PROJECT CONTINGENCY	36,173	(36,173)	0
REVISED PROJECT BUDGET	\$ 397,904	\$84,508	\$482,412

The Board previously approved a preliminary project budget in the amount of \$397,904 on November 2, 2021, (Item 3.11) and is 100% funded by RUHS Enterprise Fund 40050. This Board action will increase the project budget by \$84,508, from \$397,904 to \$482,412.

**SUBMITTAL TO THE BOARD OF SUPERVISORS COUNTY OF RIVERSIDE,
STATE OF CALIFORNIA**

All costs associated with this Board action will be 100% funded by RUHS Enterprise Fund 40050 and will be expended in FY 23/24.

Attachments:

- Change Order No. 1 for Horizons Construction Company International, Inc.
- Notice of Completion for Horizons Construction Company International, Inc.

RS:VB:RM:NS:SC:TV

FM05430009579

MT Item #22863

G:\Project Management Office\FORM 11'S\FORM 11's_In Process\22863_D3 - 009579 - RUHS-MC Kitchen Dishwashr & Flooring-
RevProjBudg,CO No.1 & NOC Horizons_121223.doc

Veronica Santillan, Principal Management Analyst 1/3/2024

Aaron Gettis, Deputy County Counsel 12/19/2023

PLEASE COMPLETE THIS INFORMATION
RECORDING REQUESTED BY:

KIMBERLY RECTOR, CLERK OF THE BOARD
4080 LEMON STREET, 1ST FLOOR CAC
P O BOX 1147 – RIVERSIDE, CA 92502

MAIL STOP # 1010

AND WHEN RECORDED MAIL TO:

RETURN TO: STOP #1010
RIVERSIDE COUNTY CLERK OF THE BOARD
P. O. BOX 1147 – RIVERSIDE, CA 92502

2024-0009316

01/10/2024 11:46 AM Fee: \$ 0.00

Page 1 of 2

Recorded in Official Records
County of Riverside
Peter Aldana
Assessor-County Clerk-Recorder



6080

THIS SPACE FOR RECORDERS USE ONLY

NOTICE OF COMPLETION
(California Civil Code §§ 8100-8118, 9200-9208)

To be recorded with County Recorder within 15 days after completion.

Notice is hereby given by the undersigned owner, a public entity of the State of California, that a public work of improvement has been completed, as follows:

Project title or description of work: Riverside University Health System Medical Center Kitchen Dishwasher Equipment and Flooring Replacement Project (FM05430009579)

Date of Completion: Date Hereof

Nature of owner: Public Entity

Interest or estate of owner: In Fee

Address of owner: Clerk of the Board of Supervisors, County Administrative Center,
4080 Lemon St., Riverside, CA 92501

Name/address of direct contractor: Horizons Construction Company International, Inc.
432 W. Meats Avenue, Orange CA 92865

Street or legal description of site: 26520 Cactus Avenue, Moreno Valley, CA 92555

Dated: 01-09-2024

Owner: County of Riverside
(Name of Public Entity)

By: *Chuck Washington*
Chuck Washington Chairman, Board of Supervisors

STATE OF CALIFORNIA)

COUNTY OF RIVERSIDE)

I am the Chairman of the governing board of the County of Riverside, the public entity which executed the foregoing notice and on whose behalf I make this verification; I have read this notice, know its contents, and the same is true. I certify under penalty of perjury that the foregoing is true and correct.

ATTEST: Kimberly Rector, Clerk

By: *Kimberly Rector*
Deputy

Executed at Riverside, California on 01/9/2024

Chuck Washington
Chuck Washington Chairman, Board of Supervisors

FORM APPROVED COUNTY COUNSEL

BY: *Lisa Sanchez* 12/14/2023
LISA SANCHEZ DATE

Updated 12/2022

PETER ALDANA
COUNTY OF RIVERSIDE
ASSESSOR-COUNTY CLERK-RECORDER

Recorder
P.O. Box 751
Riverside, CA 92502-0751
(951) 486-7000

www.riversideacr.com

CERTIFICATION

Pursuant to the provisions of Government Code 27361.7, I certify under the penalty of perjury that the following is a true copy of illegible wording found in the attached document:

(Print or type the page number(s) and wording below):

CLARIFICATION FOR SEAL for the Riverside County Board of Supervisors
(EMBOSSSED ON DOCUMENT)



Date: 01/09/2024

Signature: _____

Breanna Smith

Print Name: Breanna Smith, Clerk of the Board Assistant

COUNTY OF RIVERSIDE FACILITIES MANAGEMENT

CHANGE ORDER NO. 1

Date: 5/24/2023

Project Name: Kitchen Dishwasher & Flooring Replacement

To Contractor:
Horizons Construction Co.Int'l, Inc.
432 W. Meats Ave.
Orange, CA 92865

PeopleSoft Project No: FM 05430009579

Distribution:
 (1) Project Manager (4) Construction Manager
 (2) Contractor (5) Inspector
 (3) Fiscal (6) Architect/Engineer

You are directed to make the following changes. Changes shall include labor, material and equipment; each item to include all charges or indirect arising out of this work:

DESCRIPTION OF CHANGE	REASON FOR CHANGE ORDER	COR#	TYPE	AMOUNT
1) Furnish & Install Hobart Sink, Dishwasher System	Owner Requested	1	ADD	\$137,998.69
2)				
3)				
4)				
5)				
6)				
7)				
8)				
9)				
10)				
TOTAL				\$137,998.69

The specifications, where pertinent, shall apply to these changes.

This Change Order provides for a time extension of

Original Contract Duration (calendar days):	0	calendar days
Prior Authorized Time Extension (calendar days):	120	
Revised Construction Duration (calendar days):	0	
Original Contract Completion Date:	483	
Revised Contract Completion Date:	4/4/2022	
	7/31/2023	

NOTE: This change order is not effective until ALL signatures below are obtained, and if applicable, signature authority approval by Form 11 as indicated per Change Order Guidelines.

The undersigned contractor has given careful consideration to the change proposed, including its effect on other work already contracted for, and hereby agrees, if this change order is approved, that he will provide all equipment, furnish all materials, except as may otherwise be noted above, and perform all services necessary for the work above specified, and will accept as full payment for all costs related in any way thereto the prices shown above. Contractor expressly waives any contract right to pursue any further claim related to this change order work.

1) [Signature] 05/25/2023
 Contractor (Signature) Date

Original Contract \$ 155,175.75
 Prior Authorized ADD DEDUCT \$ 0.00
 Total Contract Prior to this Change \$ 155,175.75

Kinan Kotrash
 Contractor's Printed Name

Authorized Changes on this Change Order: \$ 137,998.69

2) [Signature] 6/14/23
 Assistant Director (Signature) Date

Amount of Contract Authorized Including this Change Order \$ 293,174.44

CHUCK WASHINGTON
 Chairman of the Board Printed Name

Pursuant to: Board Policy B-11
 M.O. and Date

3) [Signature] 6/6/23
 Architect (Signature) Date

Joe Rogowicz, P.E.
 Architect's Printed Name

4) [Signature] 6/8/23
 Project Manager (Signature) Date

Nahid N. Selbe
 Project Manager's Printed Name

ATTEST:
KIMBERLY A. RECTOR, Clerk
 By [Signature]
 DEPUTY
 JAN 9 2024 3.21

Work Order Signature Document

EZIQC Contract No.: CA-CR-GB01-062718-HCC	
<input type="checkbox"/> New Work Order	<input checked="" type="checkbox"/> Modify an Existing Work Order
Work Order #: ezIQC-HCC-FM05430009579.01	Work Order Date: <u>05/23/2023</u>
Work Order Title: Supplemental #01 - RUHS MC Kitchen Dishwasher & Flooring Replacement	
Owner Name: <u>County of Riverside</u>	Contractor Name: <u>Horizons Construction Co. Int'l, Inc.</u>
Contact: <u>Nahid Selbe</u>	Contact:
Phone: <u>(951) 955-4728</u>	Phone:
Work to be Performed	
Work to be performed as per the Final Detailed Scope of Work Attached and as per the terms and conditions of Sourcewell EZIQC Contract No CA-CR-GB01-062718-HCC.	
<u>Brief Work Order Description:</u>	
Replace existing kitchen dishwasher. Provide electrical and plumbing to new dishwasher. Provide anchorage. Provide new exhaust.	
Time of Performance	Estimated Start Date: <u>09/09/2022</u>
	Estimated Completion Date: _____
Liquidated Damages	Will apply: <input checked="" type="checkbox"/> Will Not apply: <input type="checkbox"/>
Work Order Firm Fixed Price: \$137,998.69	

Detailed Scope of Work

<p>To: Kinan Kotrash Horizons Construction Co. Int'l, Inc. 432 W. Meats Ave. Orange, CA 92865 (714) 626-0000</p>	<p>From: Nahid Selbe County of Riverside 3403 Tenth St. Riverside, CA 92501 (951) 955-4728</p>
---	---

Date Printed: May 23, 2023
Work Order #: ezIQC-HCC-FM05430009579.01
Work Order Title: Supplemental #01 - RUHS MC Kitchen Dishwasher & Flooring Replacement
Brief Scope: Replace existing kitchen dishwasher. Provide electrical and plumbing to new dishwasher. Provide anchorage. Provide new exhaust.

Preliminary Revised Final

The following items detail the scope of work as discussed at the site. All requirements necessary to accomplish the items set forth below shall be considered part of this scope of work.

ezIQC-HCC-FM05430009579.01-RUHS MC Kitchen Dishwasher & Flooring Replacement Supplemental Detailed scope of work

- 3 new 21" x 15" x 10" Stainless Steel Kitchen Sink, Single Bowl, 18 Gauge (Elkay ELU211510) With Strainer (Elkay LK99)
- New 62" Wide, 3 Station Stainless Steel Multi-Station Wash Sink (Bradley 6951)
- Stainless steel duct price increase
- HVAC equipment (exhaust fans, sheet metal jacket, and louvers) reconfigure of Ducting and
- Electrical Relocating of Existing Conduit and Junction Boxes
- Flooring changes from VCT to new epoxy stonkote ht
- 4 two-component
- Relocate Cold and Hot Water Plumbing Line Above the Ceiling
- Relocate electrical pipes and a junction box
- Furnish and Install Hobart Sinks and Disposer
- Furnish and Install stainless steel backsplash
- Furnish and Install Salvajor Disposal System
- Demo 1 Spinkler Head and Relocate
- Add 3 new Sprinkler heads
- Run New Conduits and wire for 3 horn and Strobe
- Install new 3 Horn and Strobe.

Price Break Down

General Requirements

WorkBond and Inurance \$3029.70

General Building Investigation & Electrical / Mechanical Equipment Scanning \$7,848.39

Flooring Scope of Work

Credit for VCT from Original Proposal \$(7,224.86)

Epoxy Flooring \$20,655.73

Labor Cost to Install Disposal System and Backsplash and Table \$1,946.82

Detailed Scope of Work Continued..

Work Order #: ezIQC-HCC-FM05430009579.01
Work Order Title: Supplemental #01 - RUHS MC Kitchen Dishwasher & Flooring Replacement

- Plumber Cost to Install Hobart Kitchen Dishwasher Equipment \$12,614.84
- Furnish and Install Hobart Sink, Dishwasher System, and Stainless Steel Backsplash \$20,698.90
- Fire Sprinkler Work
 - Relocate Existing Fire Sprinkler and Drain and Refill Lines \$1,245.04
 - Install New Fire Sprinkler and Piping \$1,676.61
- Plumbing Work
 - Install (2) 3" Cleanout Tees \$665.34
 - Remove and Replace (430 LF) of 1" Dia Copper Piping (excluding Material) \$12,830.72
- Furnish and Install (1) 3 Station Stainless Steel Multi-Station Wash Sink \$3,251.41
- Heating Ventilation and Air Conditioning Work
 - HVAC Repairs and Modifications for Ventilation Hood \$23,421.98
- Electrical Work
 - Conduit and Wire \$18,310.25
 - Light Fixture Retrofitting \$426.50
 - Junction Boxes and Panel Upgrades \$9,412.75
- Electronic Safety and Security Work
 - Fire Alarm Testing and Certification and Programing into Existing System \$1,093.87

Approvals

As per Associated Standard form of Construction Contract

Signatures below acknowledge review..



Contractor Kinan Kotrash, Vice President

05/25/2023
Date

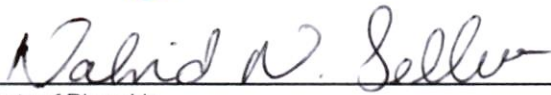

County of Riverside

5/18/23
Date

Contractor's Price Proposal - Summary

Date: May 23, 2023

Re: IQC Master Contract #: CA-CR-GB01-062718-HCC
Work Order Number: eziQC-HCC-FM05430009579.01
NJPA Number: eziQC-HCC-FM05430009579.01
Title: Supplemental #01 - RUHS MC Kitchen Dishwasher & Flooring Replacement
Contractor: Horizons Construction Co. Int'l, Inc.
Proposal Value: \$137,998.69

01 - General Requirements	\$25,380.67
09 - Finishes	\$13,430.87
11 - Equipment	\$26,852.68
21 - Fire Suppression	\$2,921.65
22 - Plumbing	\$16,747.47
23 - Heating, Ventilating, And Air-Conditioning (HVAC)	\$23,421.98
26 - Electrical	\$28,149.50
28 - Electronic Safety And Security	\$1,093.87

Proposal Total **\$137,998.69**

This total represents the correct total for the proposal. Any discrepancy between line totals, sub-totals and the proposal total is due to rounding.

The Percentage of NPP on this Proposal: **19.46%**

Contractor's Price Proposal - Detail

Date: May 23, 2023

Re: IQC Master Contract #: CA-CR-GB01-062718-HCC
 Work Order Number: ezIQC-HCC-FM05430009579.01
 NJPA Number: ezIQC-HCC-FM05430009579.01
 Title: Supplemental #01 - RUHS MC Kitchen Dishwasher & Flooring Replacement
 Contractor: Horizons Construction Co. Int'l, Inc.
 Proposal Value: \$137,998.69

Sect.	Item	Mod.	UOM	Description	Line Total																
Labor	Equip.	Material	(Excludes)																		
01 - General Requirements																					
1	01 22 16 00-0002		EA	Reimbursable Fees Reimbursable Fees will be paid to the contractor for eligible costs. The base cost of the Reimbursable Fee is \$1.00. Insert the appropriate quantity to adjust the base cost to the actual Reimbursable Fee (e.g. quantity of 125 = \$125.00 Reimbursable Fee). If there are multiple Reimbursable Fees, list each one separately and add a comment in the "note" block to identify the Reimbursable Fee (e.g. sidewalk closure, road cut, various permits, extended warrantee, expedited shipping costs, etc.). A copy of each receipt shall be submitted with the Price Proposal.	\$2,970.62																
				<table> <tr> <td>Installation</td> <td>Quantity</td> <td></td> <td>Unit Price</td> <td></td> <td>Factor</td> <td>=</td> <td>Total</td> </tr> <tr> <td></td> <td>2,700.56</td> <td>x</td> <td>1.00</td> <td>x</td> <td>1.1000</td> <td>=</td> <td>2,970.62</td> </tr> </table>	Installation	Quantity		Unit Price		Factor	=	Total		2,700.56	x	1.00	x	1.1000	=	2,970.62	
Installation	Quantity		Unit Price		Factor	=	Total														
	2,700.56	x	1.00	x	1.1000	=	2,970.62														
				User Note: Bond and Insurance 2%																	
				\$135,028.07 x 0.02 = 2700.56																	
2	01 22 20 00-0039		HR	Laborer For tasks not included in the Construction Task Catalog® and as directed by owner only.	\$1,946.82																
				<table> <tr> <td>Installation</td> <td>Quantity</td> <td></td> <td>Unit Price</td> <td></td> <td>Factor</td> <td>=</td> <td>Total</td> </tr> <tr> <td></td> <td>24.00</td> <td>x</td> <td>72.53</td> <td>x</td> <td>1.1184</td> <td>=</td> <td>1,946.82</td> </tr> </table>	Installation	Quantity		Unit Price		Factor	=	Total		24.00	x	72.53	x	1.1184	=	1,946.82	
Installation	Quantity		Unit Price		Factor	=	Total														
	24.00	x	72.53	x	1.1184	=	1,946.82														
				User Note: 2 laborer for 1 day working night shift installing sinks, disposal system and backsplash																	
3	01 22 20 00-0049		HR	Plumber For tasks not included in the Construction Task Catalog® and as directed by owner only.	\$12,614.84																
				<table> <tr> <td>Installation</td> <td>Quantity</td> <td></td> <td>Unit Price</td> <td></td> <td>Factor</td> <td>=</td> <td>Total</td> </tr> <tr> <td></td> <td>128.00</td> <td>x</td> <td>88.12</td> <td>x</td> <td>1.1184</td> <td>=</td> <td>12,614.84</td> </tr> </table>	Installation	Quantity		Unit Price		Factor	=	Total		128.00	x	88.12	x	1.1184	=	12,614.84	
Installation	Quantity		Unit Price		Factor	=	Total														
	128.00	x	88.12	x	1.1184	=	12,614.84														
				User Note: Installation of Hobart Kitchen Dishwasher Equipment																	
4	01 45 23 00-0164		EA	General Building Investigation Using Infrared Thermography , Mobilization Charge	\$2,180.88																
				<table> <tr> <td>Installation</td> <td>Quantity</td> <td></td> <td>Unit Price</td> <td></td> <td>Factor</td> <td>=</td> <td>Total</td> </tr> <tr> <td></td> <td>1.00</td> <td>x</td> <td>1,950.00</td> <td>x</td> <td>1.1184</td> <td>=</td> <td>2,180.88</td> </tr> </table>	Installation	Quantity		Unit Price		Factor	=	Total		1.00	x	1,950.00	x	1.1184	=	2,180.88	
Installation	Quantity		Unit Price		Factor	=	Total														
	1.00	x	1,950.00	x	1.1184	=	2,180.88														
				User Note: General Building Investigation of Piping and Mechanical Area inside of Kitchen Walls																	
5	01 45 23 00-0166		CSF	>1,000 To 5,000 SF, General Building Investigation Using Infrared Thermography	\$3,914.40																
				<table> <tr> <td>Installation</td> <td>Quantity</td> <td></td> <td>Unit Price</td> <td></td> <td>Factor</td> <td>=</td> <td>Total</td> </tr> <tr> <td></td> <td>1,750.00</td> <td>x</td> <td>2.00</td> <td>x</td> <td>1.1184</td> <td>=</td> <td>3,914.40</td> </tr> </table>	Installation	Quantity		Unit Price		Factor	=	Total		1,750.00	x	2.00	x	1.1184	=	3,914.40	
Installation	Quantity		Unit Price		Factor	=	Total														
	1,750.00	x	2.00	x	1.1184	=	3,914.40														
				User Note: General Building Investigation																	
6	01 45 23 00-0169		EA	Electrical /Mechanical Equipment Scanning Using Infrared Thermography , Mobilization Charge	\$1,062.48																
				<table> <tr> <td>Installation</td> <td>Quantity</td> <td></td> <td>Unit Price</td> <td></td> <td>Factor</td> <td>=</td> <td>Total</td> </tr> <tr> <td></td> <td>1.00</td> <td>x</td> <td>950.00</td> <td>x</td> <td>1.1184</td> <td>=</td> <td>1,062.48</td> </tr> </table>	Installation	Quantity		Unit Price		Factor	=	Total		1.00	x	950.00	x	1.1184	=	1,062.48	
Installation	Quantity		Unit Price		Factor	=	Total														
	1.00	x	950.00	x	1.1184	=	1,062.48														
				User Note: Mobilization of Electrical and Mechanical Equipment Investigation.																	
7	01 45 23 00-0170		HR	Electrical /Mechanical Equipment Scanning Using Infrared Thermography	\$690.63																
				<table> <tr> <td>Installation</td> <td>Quantity</td> <td></td> <td>Unit Price</td> <td></td> <td>Factor</td> <td>=</td> <td>Total</td> </tr> <tr> <td></td> <td>4.00</td> <td>x</td> <td>154.38</td> <td>x</td> <td>1.1184</td> <td>=</td> <td>690.63</td> </tr> </table>	Installation	Quantity		Unit Price		Factor	=	Total		4.00	x	154.38	x	1.1184	=	690.63	
Installation	Quantity		Unit Price		Factor	=	Total														
	4.00	x	154.38	x	1.1184	=	690.63														
				User Note: 4 hour of Equipment Electrical and Mechanical investigation.																	
Subtotal for 01 - General Requirements					\$25,380.67																
09 - Finishes																					

Contractor's Price Proposal - Detail Continued..

Work Order #: ezIQC-HCC-FM05430009579.01
 Work Order Title: Supplemental #01 - RUHS MC Kitchen Dishwasher & Flooring Replacement

21 - Fire Suppression											
18	21 13 13 00-0004	0004	MOD	For Up To 5, Add						\$218.08	
				Installation	Quantity	Unit Price	Factor	=	Total		
					1.00	194.99	1.1184		218.08		
					x	x					
				User Note:							
19	21 13 41 00-0006		LF	1-1/2" Schedule 40 Chlorinated Polyvinyl Chloride (CPVC) Fire Sprinkler Pipe						\$949.24	
				Installation	Quantity	Unit Price	Factor	=	Total		
					125.00	6.79	1.1184		949.24		
					x	x					
				User Note: Furnish and Install New Sprinkler Piping for New Sprinkler Head.							

Subtotal for 21 - Fire Suppression \$2,921.65

22 - Plumbing											
20	22 05 76 00-0039		EA	3" Cleanout Tee With Bronze Screw Plug And Round Polished Bronze Cover						\$577.32	
				Installation	Quantity	Unit Price	Factor	=	Total		
					2.00	258.10	1.1184		577.32		
					x	x					
				User Note: Furnish and Install (2) 3" Cleanout Tees.							
21	22 05 76 00-0039	0016	MOD	For Galvanized Cast Iron Parts, Add						\$66.21	
				Installation	Quantity	Unit Price	Factor	=	Total		
					1.00	59.20	1.1184		66.21		
					x	x					
				User Note:							
22	22 05 76 00-0039	0224	MOD	For Vandal Proof Screws, Add						\$21.81	
				Installation	Quantity	Unit Price	Factor	=	Total		
					1.00	19.50	1.1184		21.81		
					x	x					
				User Note:							
23	22 11 16 00-0879		LF	1" Inside Diameter Copper Pipe/Tubing Type L Assembly/Includes all hangers and couplings, elbow, tee, reducer fittings. All hangers are complete assemblies. Not for use where detail is available.						\$9,762.51	
				Installation	Quantity	Unit Price	Factor	=	Total		
					430.00	16.49	1.1184		7,930.24		
					x	x					
				Demolition	Quantity	Unit Price	Factor	=	Total		
					430.00	3.81	1.1184		1,832.27		
					x	x					
				User Note: Remove and Relocate Existing Hot and Cold Water line above Ceiling to reconfigure the layout to make it work with new Duct Work in the Way.							
24	22 11 16 00-0879	0130	MOD	For Type K Tubing Instead Of Type L, Add						\$687.70	
				Installation	Quantity	Unit Price	Factor	=	Total		
					430.00	1.43	1.1184		687.70		
					x	x					
				User Note:							
25	22 11 16 00-0879	0134	MOD	For Work In Restricted Working Space, Add						\$2,380.51	
				Installation	Quantity	Unit Price	Factor	=	Total		
					430.00	4.95	1.1184		2,380.51		
					x	x					
				User Note:							
26	22 42 16 16-0032		EA	62" Wide, 3 Station Stainless Steel Multi-Station Wash Sink (Bradley 6951)Excludes faucets.						\$3,251.41	
				Installation	Quantity	Unit Price	Factor	=	Total		
					1.00	2,907.20	1.1184		3,251.41		
					x	x					
				User Note: Furnish and Install (1) Hand Sink additional to the original Proposal							

Subtotal for 22 - Plumbing \$16,747.47

23 - Heating, Ventilating, And Air-Conditioning (HVAC)											
27	23 01 50 61-0010		SF	Sheet Metal Jacket Patch						\$2,577.46	
				Installation	Quantity	Unit Price	Factor	=	Total		
					230.00	10.02	1.1184		2,577.46		
					x	x					
				User Note: Additional Sheet metal Jack Patching Work							

Contractor's Price Proposal - Detail Continued..

Work Order #: ezIQC-HCC-FM05430009579.01
 Work Order Title: Supplemental #01 - RUHS MC Kitchen Dishwasher & Flooring Replacement

23 - Heating, Ventilating, And Air-Conditioning (HVAC)

28	23 01 60 71-0003	LB	Recovery And Recharging Of RefrigerantIncludes cleaning refrigerant gas prior to recharging.						\$3,502.83
			Installation	Quantity	Unit Price	Factor	=	Total	
				240.00	13.05	1.1184		3,502.83	
				x	x				
			User Note: New Anti-Freeze for piping						
29	23 31 13 23-0003	LB	Galvanized Steel Welded Duct						\$14,037.82
			Installation	Quantity	Unit Price	Factor	=	Total	
				645.00	19.46	1.1184		14,037.82	
				x	x				
			User Note: Additional Galvanize Steel Welded Duct work for installation of Ducting						
30	23 31 13 23-0003	0102	MOD	For Work In Restricted Working Space, Add					\$3,303.87
			Installation	Quantity	Unit Price	Factor	=	Total	
				645.00	4.58	1.1184		3,303.87	
				x	x				
			User Note:						

Subtotal for 23 - Heating, Ventilating, And Air-Conditioning (HVAC) \$23,421.98

26 - Electrical

31	26 01 50 52-0627	EA	4,800 Lumens, 2' x 4', LED Volumetric Lighting Retrofit For Existing Lensed Or Parabolic Recessed Lay-In/Troffer Fixtures (Lithonia 2VTL4R/RT)						\$426.50
			Installation	Quantity	Unit Price	Factor	=	Total	
				1.00	381.35	1.1184		426.50	
				x	x				
			User Note: install 1 additional lithonia light						
32	26 05 19 16-0066	MLF	4/c #8 AWG Cable - XLP (XHHW), 600 Volt Copper, Stranded, Placed In Conduit						\$5,024.80
			Installation	Quantity	Unit Price	Factor	=	Total	
				1.20	3,744.04	1.1184		5,024.80	
				x	x				
			User Note: run new 4c #8 awg cable as shown on e 3.2						
33	26 05 19 16-0072	MLF	4/c #4 AWG Cable - XLP (XHHW), 600 Volt Copper, Stranded, Placed In Conduit						\$8,774.60
			Installation	Quantity	Unit Price	Factor	=	Total	
				1.20	6,538.06	1.1184		8,774.60	
				x	x				
			User Note: run new 4c #4 awg cable as shown on e3.2						
34	26 05 33 13-0579	LF	1-1/4" Electrical Metallic Tubing (EMT) Conduit						\$4,072.21
			Installation	Quantity	Unit Price	Factor	=	Total	
				530.00	4.91	1.1184		2,910.41	
				x	x				
				530.00	1.96	1.1184		1,161.79	
				x	x				
			User Note: Remove and Relocate Existing Conduit Piping and Install at New Location						
35	26 05 33 13-0579	0026	MOD	For Installation Above 14', Add					\$438.64
			Installation	Quantity	Unit Price	Factor	=	Total	
				530.00	0.74	1.1184		438.64	
				x	x				
			User Note:						
36	26 05 33 16-0090	EA	4 Device, 2-1/2" Depth, 4-1/2" Steel Gang Box						\$468.65
			Installation	Quantity	Unit Price	Factor	=	Total	
				6.00	56.83	1.1184		381.35	
				x	x				
			Demolition	Quantity	Unit Price	Factor	=	Total	
				6.00	13.01	1.1184		87.30	
				x	x				
			User Note: Remove and Install New Junction Boxes for Conduit Runs						
37	26 24 13 00-0280	EA	225 Amp, 3 Phase, 480 Volt Switchboard Branch Breaker						\$4,879.00
			Installation	Quantity	Unit Price	Factor	=	Total	
				3.00	1,454.16	1.1184		4,879.00	
				x	x				
			User Note: Furnish and Install (3) 480 V breakers for the following						
			- Sink 1						
			- Sink 2						
			- Scrapper Disposal						

Contractor's Price Proposal - Detail Continued..

Work Order #: eziQC-HCC-FM05430009579.01
 Work Order Title: Supplemental #01 - RUHS MC Kitchen Dishwasher & Flooring Replacement

26 - Electrical

38	26 24 19 00-0802	EA	30 Amp Switch Rating, Fusible Disconnect Switch With 30 Amp Fuse Clips					\$1,473.51	
			Installation	Quantity	Unit Price	Factor	=	Total	
				2.00	658.76	1.1184		1,473.51	
			User Note: furnish and install 2 30 amp switch disconnect switches						
39	26 24 19 00-0803	EA	60 Amp Switch Rating, Fusible Disconnect Switch With 60 Amp Fuse Clips					\$2,591.59	
			Installation	Quantity	Unit Price	Factor	=	Total	
				3.00	772.41	1.1184		2,591.59	
			User Note: furnish and install 3 60 amp disconnect switches						

Subtotal for 26 - Electrical **\$28,149.50**

28 - Electronic Safety And Security

40	28 46 21 33-2265	DAY	Test And Certification For Tie Into Existing Systems					\$773.43	
			Installation	Quantity	Unit Price	Factor	=	Total	
				1.00	691.55	1.1184		773.43	
			User Note: Testing and Certification of Programing into system.						
41	28 46 21 33-2266	HR	Test And Certification Of Fire Alarm SystemGCC Programming and Engineering; Programming of the Fire Alarm System.					\$320.44	
			Installation	Quantity	Unit Price	Factor	=	Total	
				2.00	143.26	1.1184		320.44	
			User Note: Programming Existing Smoke Detector into existing System.						

Subtotal for 28 - Electronic Safety And Security **\$1,093.87**

Proposal Total **\$137,998.69**

This total represents the correct total for the proposal. Any discrepancy between line totals, sub-totals and the proposal total is due to rounding.

The Percentage of NPP on this Proposal: **19.46%**

Subcontractor Listing

Date Printed: 5/23/2023

Work Order Number: ezIQC-HCC-FM05430009579.01

Work Order Title: Supplemental #01 - RUHS MC Kitchen Dishwasher & Flooring Replacement

Amount: \$137,998.69

Name of Contractor	Duties	Contractors License #	State DIR #	Amount	%
No Subcontractors have been selected for this Work Order				\$0.00	0.00

**Job Order Contract
Contractor's Non-Prepriced Worksheet**

Date: 05/23/2023

Re: 094940.01 - RUHS MC Kitchen Dishwasher & Flooring Replacement
Supplemental

SECTION	ITEM	UOM	DESCRIPTION
11 00 00			Material Cost for Disposal System and Stainless Steel Backsplash

Factor: 1.00	Unit Price: \$20,698.90
Quantity 1 EA	Line Item Total: \$20,698.90
Proposal Total: \$138,057.77	% of Work Order Total: 15%

Contractor Duties:

A. \$ _____	Direct Labor Costs (Attach Schedule of Crew and Payroll Records)
B. \$ 20,698.90	Direct Material Costs (Attach 3 Quotes)
C. \$ _____	Direct Equipment Costs (Attach 3 Quotes)
D. \$ _____	Allowable Overhead Cost (55%) = A x .55
E. \$ _____	Allowable Profit (10%) = (A+B+C) x .10

Subcontractor Duties:

F. \$ _____	Cost of Subcontractor to Contractor (Attach 3 Quotes)
G. \$ _____	Contractor Allowance (5%) = F x .05
H. \$ _____	Contractor's Overhead for Subcontractor Costs F x 0% for NPP tasks < 10% of Work Order Total F x 7% for NPP tasks 10-20% of Work Order Total F x 10% for NPP tasks > 20% of Work Order Total
\$ 20,698.90	Total Installed Price = (A+B+C+D+E+F+G+H)

Convert to Unit Price

Quotes

(Attached quotes from listed suppliers/subcontractors. A Justification Letter must be attached if 3 quotes are not furnished.)

1	Terra Universal	\$ 3,873.66
2	Frontier Food Service	\$ 16,825.24
3		\$

Order Confirmation 303418

Please inspect this confirmation and report discrepancies immediately to Customer Service.

800 S. Raymond Ave., Fullerton, CA 92831 USA **Tel +1 714 578-6100 * Fax +1 714-578-6020**

PO/Request ID	Ordered	Released	Needed	Est. Ship	Payment Terms	TUI Ref #
verbal order	9/27/2022	9/29/2022		11/3/2022	Prepaid on Credit Card	303418

Order Manager	Partner	Sales Team Leader	Sales Manager
Kenny Tranluu, B.S. Biology Phone: +1 714-578-6113 Kenny@TerraUniversal.com	Andre Vignau, B.S. BioChemistry Phone: +1 714-578-6114 Fax: +1 714-578-3114 andre@terrauniversal.com	Evan Messenger, B.S. Microbiology Phone: +1 714-578-6124 Cell: +1 714-872-6891 Fax: +1 714-578-3105 Evan@TerraUniversal.com	Rod Behnia, BS, MS EE Phone: +1 714-578-6108 Cell: +1 949-690-4899 Fax: +1 714-578-3108 Rod@TerraUniversal.com

Local Sales & Support Representative	Industry	Trans ID
TUI Direct Support - T000, Fullerton CA	Construction/Builder	

Requested By	End User	Invoice to	Client # 302674
Mike Ortega Horizon Construction 1173 N. Patt Street Anaheim, CA 92801 W 714-626-0000 mike@horizonscci.com horizonscci.com		Accounts Payable Horizon Construction 1173 N. Patt Street Anaheim, CA 92801 Tel Main: 714-626-0000 ATTN: Account Payable	

Ship To (See Term 2)	Shipping Terms (See Term 4)	Order Summary																		
Horizon Construction 432 West Meats Ave Orange, CA 92865 UNITED STATES ATTN: Michael Ortega	F.O.B.: Destination Freight & Handling: Bill Line Item Partial Ship OK? Yes Shipped Via: Unspecified Surface Ship Acct # Tracking #	<table border="0"> <tr><td>Products & services list</td><td></td></tr> <tr><td>Special Promotional</td><td>\$3,106.00</td></tr> <tr><td>Discount For Prompt Payment</td><td>-\$205.00</td></tr> <tr><td>Products & Services Net</td><td>\$2,901.00</td></tr> <tr><td>Shipping & handling</td><td>\$721.02</td></tr> <tr><td>Estimated Tax 7.75%</td><td>\$251.64</td></tr> <tr><td>Order total</td><td>\$3,873.66</td></tr> <tr><td>Deposits Charged (Applied)</td><td>(\$3,873.66)</td></tr> <tr><td>Net Due Before Due Date*</td><td>\$0.00</td></tr> </table>	Products & services list		Special Promotional	\$3,106.00	Discount For Prompt Payment	-\$205.00	Products & Services Net	\$2,901.00	Shipping & handling	\$721.02	Estimated Tax 7.75%	\$251.64	Order total	\$3,873.66	Deposits Charged (Applied)	(\$3,873.66)	Net Due Before Due Date*	\$0.00
Products & services list																				
Special Promotional	\$3,106.00																			
Discount For Prompt Payment	-\$205.00																			
Products & Services Net	\$2,901.00																			
Shipping & handling	\$721.02																			
Estimated Tax 7.75%	\$251.64																			
Order total	\$3,873.66																			
Deposits Charged (Applied)	(\$3,873.66)																			
Net Due Before Due Date*	\$0.00																			

Critical Notes
 CriticalNoteText

*sales tax, shipping and handling charges, if applicable, will be added. Late charges will apply if paid late (see Term #1)

Pay to Terra Universal, address above

[Terra Universal User Account Access](#)

Browse Terra's selection of cleanroom and laboratory seating

Learn More

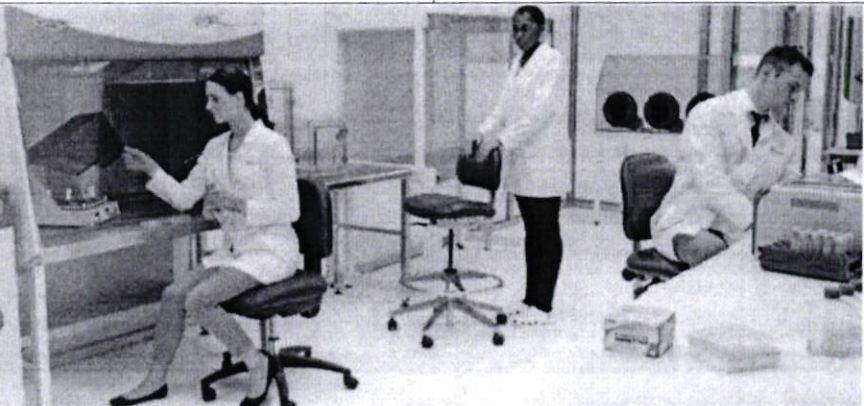

Detailed list of products, services, specifications and costs follows

Order Confirmation 303418

Please inspect this confirmation and report discrepancies immediately to Customer Service.

800 S. Raymond Ave., Fullerton, CA 92831 USA Tel +1 714 578-6100 * Fax +1 714-578-6020

PO/Request ID verbal order Ordered 9/27/2022 Est. Ship 11/3/2022

#	Part Number	Qty Ord	Units Of Count	Unit	Unit Price	Unit Disc	Extended
1	7900-EA-SUP-3020757 *	1	EA	EA	\$2,922.00	\$205.00	\$2,717.00 T

Worktables: Backsplash, Stainless Steel, 36" x 60"

• Description: 36" x 60" 14 gauge 300 series stainless steel top worktable; backsplash, stainless steel legs and undershelf

Country of Origin: USA

[Click here to view this product on our web site](#)



<p>Worktables: Backsplash, Stainless Steel, 36" x 60"</p> <p>• Description: 36" x 60" 14 gauge 300 series stainless steel top worktable; backsplash, stainless steel legs and undershelf</p> <p>Country of Origin: USA</p> <p>Click here to view this product on our web site</p>							
---	--	--	--	--	--	--	--

2	9999-FrtDest	1			\$721.02	\$0.00	\$721.02 T
---	--------------	---	--	--	----------	--------	------------

Shipping Costs - FOB Destination

- Terra's sole shipping terms are FOB destination, Bill Line Item
- This line item covers Terra's costs of freight, handling and declared value coverage (DVC), with FOB Destination
- Terra assumes full responsibility to cover shipping losses and replaces or repairs damaged goods, if needed, eliminating third-party claim disputes and customer's need to file freight claims in the event of damage during transit
- Terra shipping prevents storage charges: Terra ships promptly upon product completion, eliminating storage charge of 1% of order total per day that applies after standard holding period of 3 days after order completion. Storage fees must be paid in full before order is released for shipping
- All shipping costs are only ESTIMATES and are subject to revision if actual freight costs change
- Freight quotes are for reference only and are subject to change at any given time, shipping rates constantly change and Terra may need to re-quote the shipment before delivery

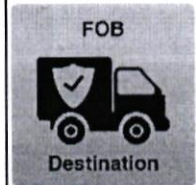

<p>Shipping Costs - FOB Destination</p> <ul style="list-style-type: none"> • Terra's sole shipping terms are FOB destination, Bill Line Item • This line item covers Terra's costs of freight, handling and declared value coverage (DVC), with FOB Destination • Terra assumes full responsibility to cover shipping losses and replaces or repairs damaged goods, if needed, eliminating third-party claim disputes and customer's need to file freight claims in the event of damage during transit • Terra shipping prevents storage charges: Terra ships promptly upon product completion, eliminating storage charge of 1% of order total per day that applies after standard holding period of 3 days after order completion. Storage fees must be paid in full before order is released for shipping • All shipping costs are only ESTIMATES and are subject to revision if actual freight costs change • Freight quotes are for reference only and are subject to change at any given time, shipping rates constantly change and Terra may need to re-quote the shipment before delivery 							
---	--	--	--	--	--	--	--

3	9999-CreditCard	1	\$\$ of 1	\$\$	\$184.00	\$0.00	\$184.00 T
---	-----------------	---	-----------	------	----------	--------	------------

Credit Card Convenience Fee

- Credit card processing charges (the fees banks charge Terra) have increased, especially on so-called "mileage cards."
- Raising list prices to cover these costs would be unfair to the majority of customers who pay directly, without using a credit card.
- A credit card convenience fee is charged on all credit card orders to offset costs charged by banks.
- Credit card convenience fee rate is 5%



<p>Credit Card Convenience Fee</p> <ul style="list-style-type: none"> • Credit card processing charges (the fees banks charge Terra) have increased, especially on so-called "mileage cards." • Raising list prices to cover these costs would be unfair to the majority of customers who pay directly, without using a credit card. • A credit card convenience fee is charged on all credit card orders to offset costs charged by banks. • Credit card convenience fee rate is 5% 							
--	--	--	--	--	--	--	--

Continued from previous page

Order Confirmation 303418

Please inspect this confirmation and report discrepancies immediately to Customer Service.

800 S. Raymond Ave., Fullerton, CA 92831 USA **Tel +1 714 578-6100 * Fax +1 714-578-6020**

PO/Request ID verbal order **Ordered** 9/27/2022 **Est. Ship** 11/3/2022

#	Part Number	Qty Ord	Units Of Count	Unit	Unit Price	Unit Disc	Extended
4	9999X-PaidByCrdtCrd	1	EA	EA	(\$3,873.66)	\$0.00	(\$3,873.66)

Do NOT Pay, Order Paid By Credit Card -- Thank You!
 • Order paid by credit card -- no balance due on this invoice.



Continued from previous page

Please inspect this confirmation and report discrepancies immediately to Customer Service.

800 S. Raymond Ave., Fullerton, CA 92831 USA

Tel +1 714 578-6100 * Fax +1 714-578-6020

PO/Request ID	verbal order	Ordered	9/27/2022	Est. Ship	11/3/2022
---------------	--------------	---------	-----------	-----------	-----------

Terms of sale:

Thank you for placing your order with Terra under the terms presented below. Terra does not guarantee the suitability of Terra-supplied equipment for your specific application, only that it will perform to the specifications documented above, not including oral instructions or other requirements not listed. Terra is not responsible for any consequential damages or loss of revenue resulting from performance issues or delays in manufacturing or installation. Terra provisionally accepts this order subject to Terra's acceptance of customer-approved drawings, receipt of the initial payments and any other required documents & export license, credit approval and to the terms and conditions shown below. Unless specified on the sales order, Terra's terms and conditions supersede any conflicting terms in your PO or RFP/RFQ. Any terms on your PO that conflict with Terra's terms are not accepted unless approved in writing by an authorized Terra employee and documented by returning a signed copy of your PO. Summarized, Terra's terms are:

NOTE: Freight, handling, DVC & taxes, if applicable, will be added to the order confirmation unless separately listed. Orders are not accepted, released for production, or shipped until Terra reviews and accepts the PO, payment terms, credit reports, pricing, and receipt of any required documents such as drawing approvals and advance payments. Due to price fluctuations and current market conditions, pricing and specifications may expire/change (written notice given to customer). Pricing may subject to change upon receipt of purchase order. In the unlikely event that prices and specifications must be changed, written notice will be given to customer.

1. Payment terms are shown on the order confirmation. A late charge is invoiced on products & services unpaid 15 days after their due dates and must be paid to restore open account status. The late charge is determined based on whichever of these is greater:

(a) 10% of the products and services invoiced on, or (b) the discount granted (if any). Invoice due date is based on invoice date.

2. This order may not be accepted without receipt of Terra's order confirmation. This order has been accepted with the understanding that the "Ship To" addressee and location provided by you are the final destination of these products for purposes of (DOC) U.S. Dept. of Commerce export regulations and that you will notify Terra immediately if these change. The DOC prohibits Terra, and all U.S.-based companies, from engaging in business activities with organizations located within countries subject to permanent trade embargoes or targeted comprehensive sanctions pursuant to the Export Administration Regulations (EAR). Export, or re-export, of select products to countries subject to limited trade sanctions may require the purchase of an export license. If an export license is required, a processing charge is due with the order. Time required to process export licenses by the DOC is undeterminable, therefore orders requiring export licenses are not accepted or released for production until the licenses are approved and received.

3. Since many products are manufactured or purchased to order and depend on workloads at the time the order is ready for manufacturing and/or vendor availability, it is impossible to guarantee delivery dates. All Terra's shipping/delivery dates are estimates and Terra's failure to ship on time is never grounds for cancellation or termination of an order, or an excuse to withhold payment. Terra does not accept orders with terms, penalties or payment conditioned on meeting guaranteed shipping/delivery dates. This order will be accepted with the understanding that shipping/delivery date is a nonguaranteed estimate and not grounds for cancellation, termination or withholding payment. Terra offers guaranteed ship dates; inquire about optional FasTrak coverage.

4. FOB point is stated on the order confirmation. Terra handles shipments based on its shipping policy. FOB "Destination" orders ship "prepaid" or "prepaid and add" with freight cost plus handling and DVC charges added to each shipment. FOB Destination means that risk of loss transfers to the customer when the shipment is delivered. Terra directly handles losses and damages on FOB Destination shipments. In rare occasions or for some international shipments, other FOB terms may be used and shown on order confirmations. Each will have its own meanings and special responsibilities. For more information please contact your account manager. To reduce costs and expedite delivery, it may be necessary to ship from different factories and in partial shipments.

5. Orders accepted, released and processed by Terra cannot be cancelled or returned except with prior written Terra approval and on terms that compensate Terra for work performed and expenses incurred. If cancellation is approved by Terra, cancellation fees may apply. Custom items, specialty items or items not purchased from Terra, and items modified or damaged by improper use, repairs, application of labels or nameplates are not returnable nor cancellable.

6. Terra holds items at no charge for a maximum of 3 business days after notification of order completion. After 3 days, a storage fee of 1% of the product purchase price will be applied daily. If the cumulative storage fee exceeds the purchase price, the items will be considered abandoned and returned to stock. No refund will be given.

7. All returns must be approved by Terra in writing in advance and may be assessed restocking and handling charges. No returns will be accepted without an RMA. All items accepted by Terra must be in original condition, in original shipping containers, and returned FOB Terra freight prepaid. Terra may elect to issue store credit against future orders rather than cash refunds. Store credits expire in 60 days, unless a waiver is applied and approved by Terra.

8. Terra's warranty is as shown on <https://www.terrauniversal.com/warranty/>.

9. **Arbitration:** Any controversy or claim arising out of or relating to this contract, or the breach thereof, shall be settled by arbitration administered by the American Arbitration Association in accordance with its Commercial Arbitration Rules, and judgment on the award rendered by the arbitrator(s) may be entered in any court having jurisdiction thereof. Arbitration shall be the exclusive forum to resolve any such claims or controversies and, except for the entry of judgment upon any arbitration award, the parties hereto expressly waive their respective right to seek relief in any state or federal court. Further, this agreement shall be governed by the laws of the State of California and any arbitration hearing shall be conducted in Orange County, California.

⚠ WARNING: Cancer and Reproductive Harm - www.P65Warnings.ca.gov

UL-Approved Cleanroom Control Systems

- Streamlines cleanroom permitting and certification
- Simple plug-and-play design optimizes installation
- Integrates with an unlimited number of fan filter units, lights and duplex outlets
- Scalable, flexible, designed for modular and stick-built rooms
- Completely eliminates hard wiring

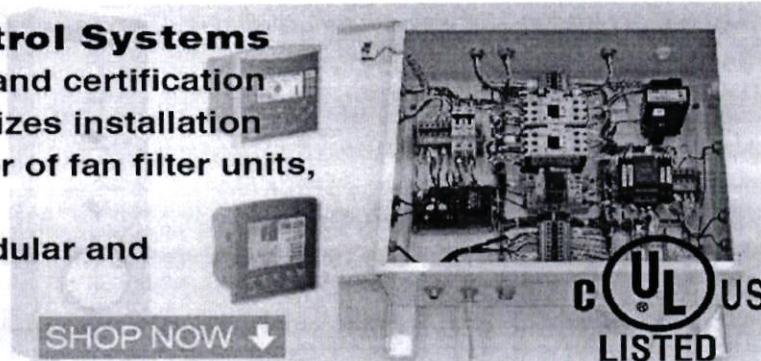

Thanks for letting us quote!

Totals on Page 1

Last Page

Please inspect this confirmation and report discrepancies immediately to Customer Service.

800 S. Raymond Ave., Fullerton, CA 92831 USA Tel +1 714 578-6100 * Fax +1 714-578-6020

PO/Request ID	verbal order	Ordered	9/27/2022	Est. Ship	11/3/2022
---------------	--------------	---------	-----------	-----------	-----------

Door and Windows

Terra's BioSafe Windows and Doors are simple to install and easy to clean!

[SHOP NOW](#) ↓

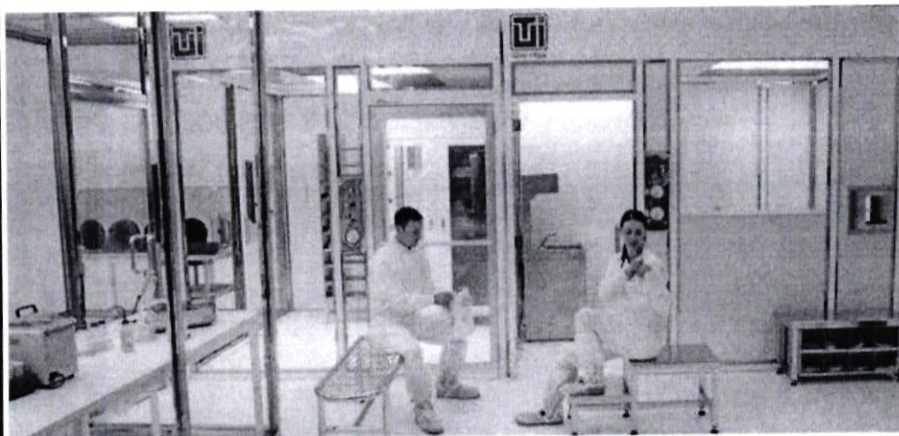
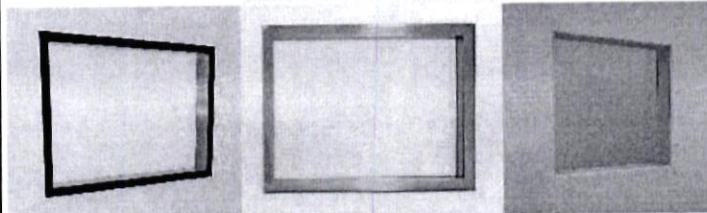
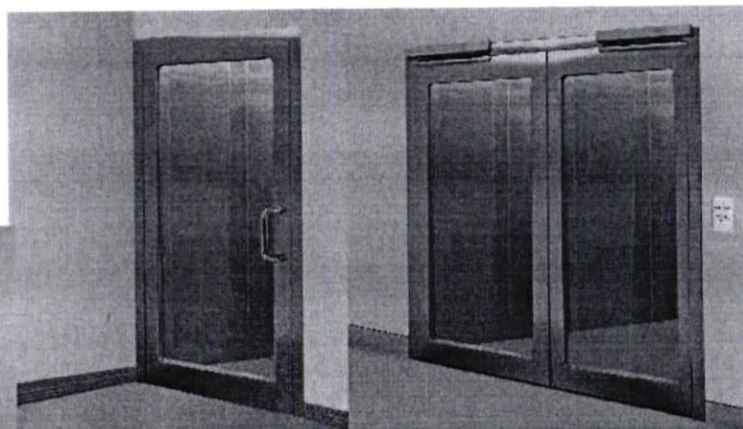

Furnish your cleanroom with Terra's complete line of in-stock equipment

[Shop Now](#)



Quote

09/30/2022

Project:
RUHS

From:
Frontier Foodservice
Ray Abbey
Tustin
Orange County, CA 92780
909-894-8560
714-721-4997 (Contact)

*****Disposers are outlawed in most of California, please verify with municipality that they will be accepted at installation location. These are not returnable.*****

If for resale, please supply reseller license or tax added

Item	Qty	Description	Sell	Sell Total
1	1 ea	DISPOSAL SYSTEM Salvajor Model No. 500-PSM Pot/Pan ScrapMaster, scrapping, pre-flushing & disposing system with water recirculation, large top opening to accommodate pots & pans, 5 HP disposer, salvage basin & silverware trap, stainless steel construction, with NEMA 4 HYDROLOGIC® control panel with patented operator sensor, water saving mode, safety line disconnect & LCD readout, UL, CSA, CE, NSF	\$13,382.88	\$13,382.88
	1 ea	Domestic factory authorized start up within 75 mile radius of an authorized service agency, standard		
	1 ea	Domestic factory authorized demo, standard		
	1 ea	460/480v/60/3-ph, 8.13 amps		
	1 ea	RSS Remote start/stop switch for all controls (HydroLogic control with operator sensor comes standard mounted to SM/PSM models. ONLY add if additional on/off control is required)	\$441.28	\$441.28
	1 ea	980104 Mounting bracket for RSS, MSS, MSS-LD, MRSS, MRSS-LD	\$197.12	\$197.12
	1 ea	980211 Seismic Flange for Support Leg (5 included)	\$305.76	\$305.76
		ITEM TOTAL:		\$14,327.04
2	1 ea	SET IN PLACE Custom Receive, Coordinate Delivery, Assemble, Set in Place, Remove and Dispose of Packaging. No Anchoring or Final Connections.	\$1,500.00	\$1,500.00
		ITEM TOTAL:		\$1,500.00

Frontier Foodservice

09/30/2022

Merchandise	\$15,827.04
Freight	\$998.20
Installation	
Total	\$16,825.24

Acceptance: _____ Date: 10/04/2022

Printed Name: Michael Ortega

Project Grand Total: \$16,825.24

SALVAJOR ScrapMaster®

Job: _____ Item No.: _____

Model SM

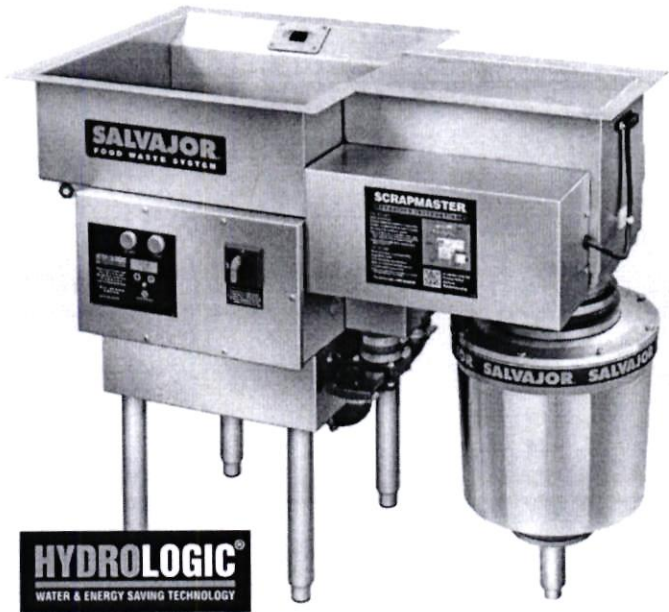

A Scrapping, Pre-Flushing and Disposing System with:

- Standard Scrap Basin, Model SM
- Pot/Pan Scrap Basin, Model PSM

Recirculated Water used by the system for pre-flushing will reduce water and sewer cost by thousands of dollars per year. The ScrapMaster consumes only 7 gallons of new water per minute while the heavy pre-flushing plume recirculates at a 30 gallon rate.

Scrapping Speed is more than doubled by a single operator as both hands are used for scrapping. The ScrapMaster's powerful plume of water takes the place of a less productive pre-rinse spray.

Problem Dishes, Trays and Cookware with dried or baked-on food need much less hand work as they can be soaking in the scrap basin while the scrapping process continues.

Design Flexibility of the ScrapMaster allows the pre-flushing and scrapping of all types of soiled tableware and cookware. The standard scrap basin accepts all soiled tableware as well as school trays. The pot/pan scrap basin accommodates dishes, school trays, pots, pans and even 26 inch sheet pans.

Less Splashing occurs with the ScrapMaster water plume compared to a pre-rinse spray.

📶 **HydroLogic Control Panel** saves water and energy. Includes patented operator sensing technology with water saving mode.

U.S. Pat. No. 7,815,134

Job: _____ Item No.: _____

Model PSM



TYPICAL INSTALLATIONS

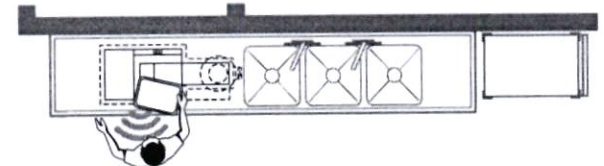
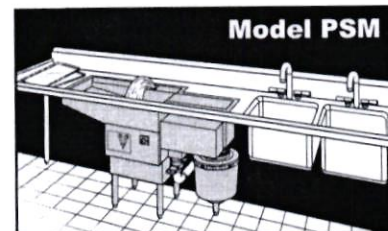
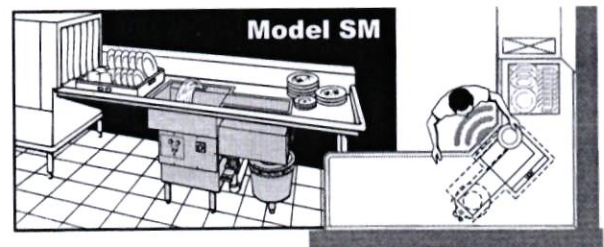

ScrapMaster® Model SM

Model SM Drain Piping

2" tank reservoir drain can be run separately or be tied in with 2"-3" disposer drain.

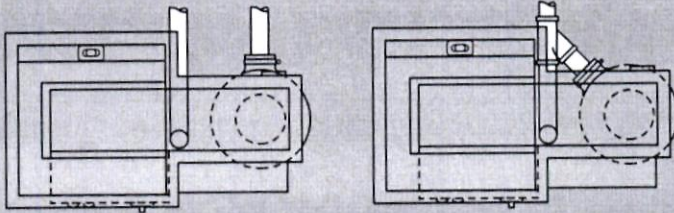

All connections are to be made by qualified personnel who will observe all local and national codes.

SM & PSM Legend

- A** Disposer outlet can be rotated at most any angle by rotating disposer. Rubber drain accepts 2" piping or 3" piping by removing drain insert.
- B** Tank reservoir drain – Plumb 2" piping from valve to floor drain or connect to disposer drain piping ahead of P trap.
- C** Disposer electrical connection.
- D** Disposer to control connection.
- E** Incoming electrical connection.
- F** Hot and cold water connection. 1/2" NPT
- G** Recirculating water valve.

NOTE: Dimensions in parenthesis are in centimeters

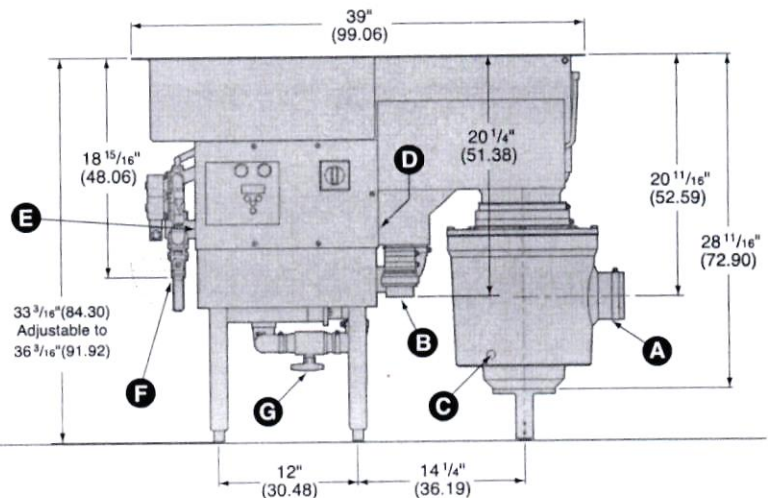
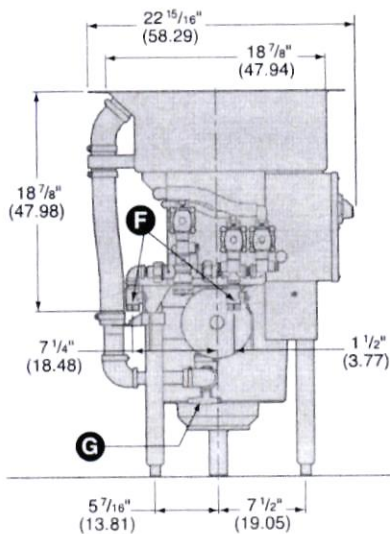
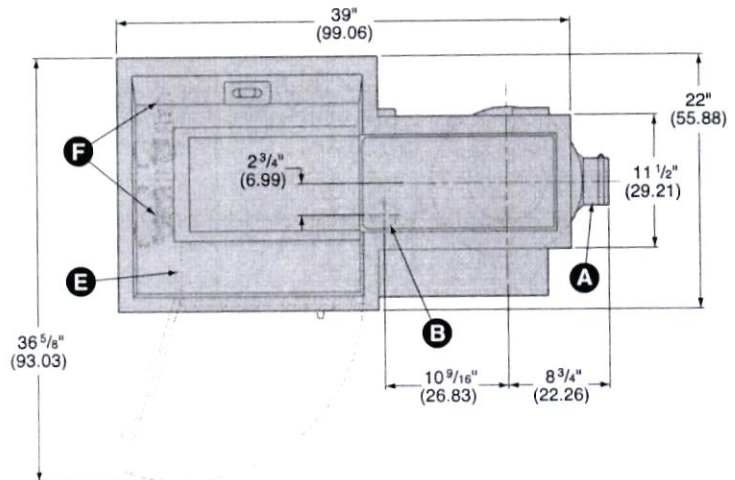
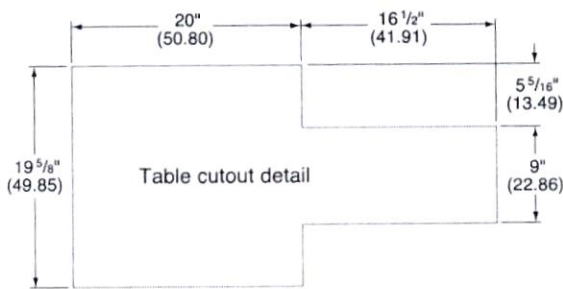

Pot/Pan ScrapMaster® Model PSM

Design Tips

- Leave a 24" space between the ScrapMaster and dishwasher. Note: If dishwasher orientation is right of the ScrapMaster, the dish rack can sit on top of the disposer access cover (16"). In this case, only 4" is needed between the ScrapMaster and dishwasher.
- Do not direct connect ScrapMaster with inline trap or interceptor.
- Unit is multi-directional. No need to specify left or right hand version.
- Optional bracket available for remote start/stop only.

Model PSM Drain Piping

2" tank reservoir drain can be run separately or be tied in with 2"-3" disposer drain.

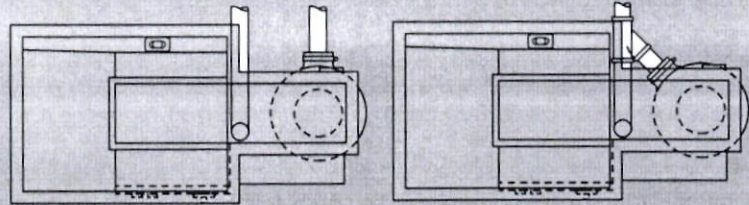

All connections are to be made by qualified personnel who will observe all local and national codes.

NOTE: Dimensions in parenthesis are in centimeters

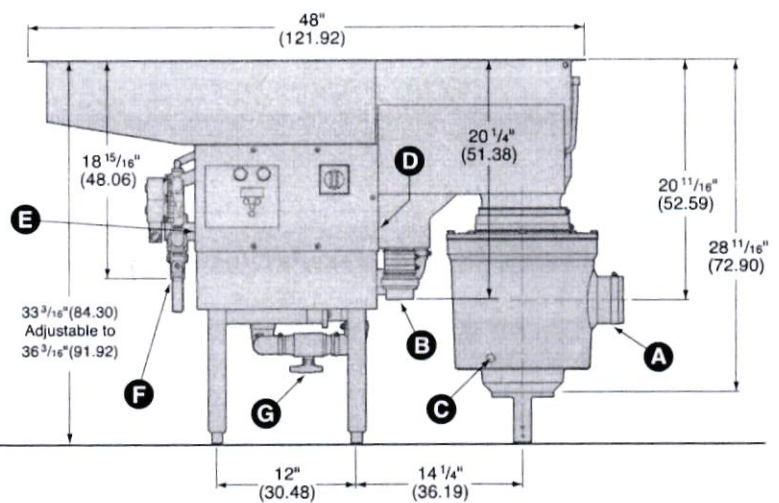
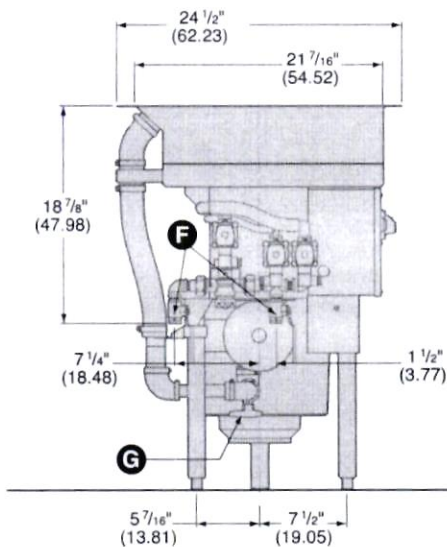
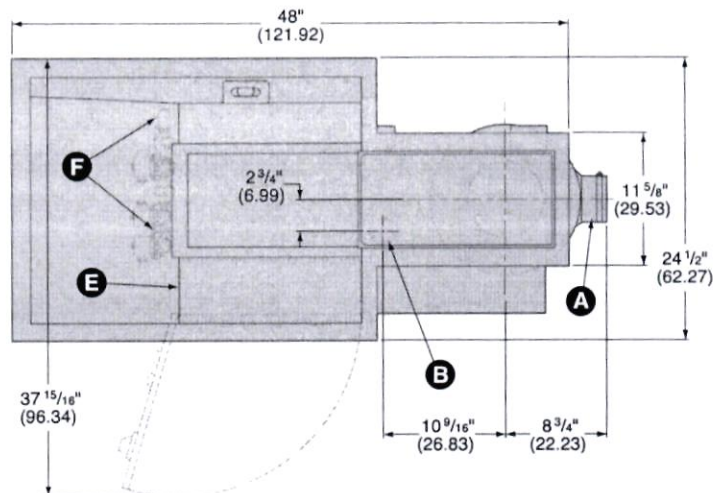
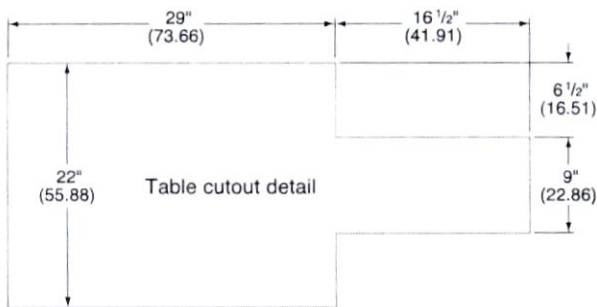

ScrapMaster System

Model SM & Model PSM Specifications

CONSTRUCTION

- Stainless Steel Components
- Salvage Basin
- Disposer Safety Cover
- Adjustable Legs
- Control Panel

ELECTRICAL

- Pre-wired NEMA 4 Panel
- Patented Operator Sensor
- Watertight Conduit/Fittings
- Separate Component Grounding
- Thermally Protected Motors
- Totally Enclosed Motors
- Line Voltage Disconnect
- Disposer Safety Switch
- 24 Volt Safety Circuitry

PLUMBING

- Corrosion Resistant Components
- Automatic Water Blender
- Solenoid Valves
- Unions
- Check Valves
- Incoming Water Valves
- Non-clogging Pump Design
- Backflow Prevention Device
- Quick Opening Drain Valve

SAMPLE SPECIFICATIONS

Unit shall be a ScrapMaster (or Pot/Pan ScrapMaster) pre-flushing scrapping and food waste disposing system with recirculating water as manufactured by Salvajor.

Model ___ SM (or PSM), ___ Volts, ___ Hz, ___ Phase.

Furnished with a pre-wired HydroLogic control panel, sensor and stainless steel NEMA 4 watertight enclosure.

SALVAJOR.

Manufacturers of Commercial Food Waste Solutions - Since 1944

4530 East 75th Terrace Kansas City, MO 64132-2081, USA

816.363.1030 | Toll Free: 1.800.725.8256 | Service: 1.888.725.8256 | Fax: 1.800.832.9373

sales@salvajor.com | service@salvajor.com | www.salvajor.com

MODELS AVAILABLE

Model	Model	Disposer
<input type="checkbox"/> 300 SM	<input type="checkbox"/> 300 PSM	3 HP
<input type="checkbox"/> 500 SM	<input type="checkbox"/> 500 PSM	5 HP

ACCESSORIES

- Remote Start-Stop Button
- Remote Mounting Bracket
- Correctional Package
- Stainless Steel Dejamming Prong

VOLTAGES AVAILABLE

(SPECIFY EXACT OPERATING VOLTAGE)

<input type="checkbox"/> 208V	<input type="checkbox"/> 230V	<input type="checkbox"/> 460V, 60 Cycle, 3 Phase
Disposer	3-5 HP	208-230-460V
Pump	3/4 HP	208-230-460V
Separator	1/6 HP	208-230-460V

FULL LOAD AMPS

MODEL	TOTAL FULL LOAD AMPS			THREE PHASE
	208V	230V	460/480V	Total HP
300-SM/PSM	12.7	11.7	5.9	4
500-SM/PSM	17.7	16.2	8.2	6

UTILITIES REQUIRED

208, 230 or 460 Volt, 60 cycle, 3 phase electric service, 3/4" hot and cold water supply and reduce to 1/2" at connection. 2" or 3" waste line, 2" tank reservoir drain.

(Specifications subject to change without notice.)





U.S. Pat. No. 7,815,134



Disposer
not included
in listing.

SALVAJOR® Pre-Wired Control Panels

For Food Waste Disposer Models 100 - 200 - 300 - 500

<p>MSS</p> 	<p>NON-REVERSING</p> <p>1-PHASE 115V, 208V, 230V</p> <p>3-PHASE 208V, 230V, 460V</p> <p><i>For use in small to medium kitchens, vegetable prep areas, pot sink and soiled dish tables.</i></p>	<p>SPECIFICATIONS:</p> <ul style="list-style-type: none"> • NEMA 4 Stainless Steel Corrosion-Resistant Enclosure • Magnetic Contactor • START/STOP Push Buttons • Terminal Strip Connections 	<p>ACCESSORIES:</p> <ul style="list-style-type: none"> • Safety Line Disconnect (LD) • P - Mounted Solenoid Valve and Flow Control • PP - Mounted Solenoid Valve, Flow Control and Pressure Switch • #980104 - Mounting Bracket
<p>MRSS</p> 	<p>MANUAL REVERSING</p> <p>1-PHASE 115V, 208V, 230V</p> <p>3-PHASE 208V, 230V, 460V</p> <p><i>For use in small to medium kitchens, vegetable prep areas, pot sink and soiled dish tables.</i></p>	<p>SPECIFICATIONS:</p> <ul style="list-style-type: none"> • NEMA 4 Stainless Steel Corrosion-Resistant Enclosure • Manual Reversing Magnetic Contactors • START/STOP Push Buttons • Forward/Reverse Switch 	<p>ACCESSORIES:</p> <ul style="list-style-type: none"> • Safety Line Disconnect (LD) • P - Mounted Solenoid Valve and Flow Control • PP - Mounted Solenoid Valve, Flow Control and Pressure Switch • #980104 Mounting Bracket
<p>ARSS-2</p> 	<p>AUTOMATIC REVERSING</p> <p>1-PHASE 115V, 208V, 230V</p> <p>3-PHASE 208V, 230V, 460V</p> <p><i>For use in medium to large kitchens, all prep areas and soiled dish tables.</i></p>	<p>SPECIFICATIONS:</p> <ul style="list-style-type: none"> • NEMA 4 Stainless Steel Watertight Enclosure • 24 Volt Safety Circuitry • Automatic Reversing Magnetic Contactors • Terminal Strip Connections • START/STOP Push Buttons 	<p>ACCESSORIES:</p> <ul style="list-style-type: none"> • P - Mounted Solenoid Valve and Flow Control • PP - Mounted Solenoid Valve, Flow Control and Pressure Switch • #980105 Mounting Bracket
<p>ARSS</p> 	<p>AUTOMATIC REVERSING</p> <p>1-PHASE 115V, 208V, 230V</p> <p>3-PHASE 208V, 230V, 460V</p> <p><i>For use in medium to large kitchens, all prep areas and soiled dish tables.</i></p>	<p>SPECIFICATIONS:</p> <ul style="list-style-type: none"> • NEMA 4 Stainless Steel Watertight Enclosure • Solid State Control Circuit • 24 Volt Safety Circuitry • 20 Second Drain Flush • Automatic Reversing Magnetic Contactors • Terminal Strip Connections • START/STOP Push Buttons • Energy/Water-Saving Mode • 3 Second Reversing Safety Delay • User Adjustable Run Time • LCD Status Readout • Operator Sensor Capable 	<p>ACCESSORIES:</p> <ul style="list-style-type: none"> • Safety Line Disconnect (LD) • P - Mounted Solenoid Valve and Flow Control • PP - Mounted Solenoid Valve, Flow Control and Pressure Switch • #980105 Mounting Bracket • #980609 Operator Sensor Includes Low Flow Solenoid Valve <p> Product configurations protected by U.S. Pat. No. 7,815,134 when used with sensor</p>

SAFETY FEATURE:

All Salvajor Controls include an operator safety feature that prevents automatic starting of the disposer after a power interruption.

ALL SALVAJOR CONTROLS ARE:



Disposer Controls

DETAILS AND DIMENSIONS

Typical Installation of a Salvajor Disposer with: MSS, MRSS, ARSS-2 or ARSS Control

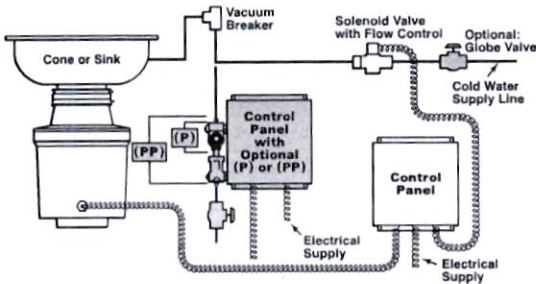

980104 Optional Mounting Bracket

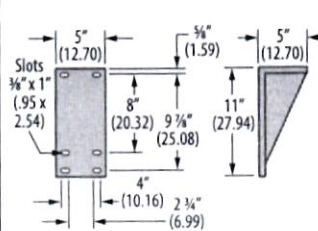

980105 Optional Mounting Bracket

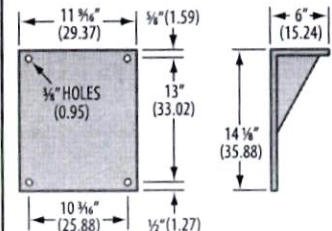

ITEM NUMBERS FOR ORDERING

CONTROL MODEL	VOLTS	PHASE	ITEM NO.
MSS	115	1	MSS4
	208-230	1	MSS5
	208-230	3	MSS7
	460	3	MSS9
MSS-LD	115	1	MSSLD4
	208-230	1	MSSLD5
	208-230	3	MSSLD7
	460	3	MSSLD9
MRSS	115	1	MRSS4
	208-230	1	MRSS5
	208-230	3	MRSS7
	460	3	MRSS9
MRSS-LD	115	1	MRSSLD4
	208-230	1	MRSSLD5
	208-230	3	MRSSLD7
	460	3	MRSSLD9
ARSS-2	115	1	ARSS24
	208-230	1	ARSS25
	208-230	3	ARSS27
	460	3	ARSS29
ARSS	115	1	ARSS4
	208-230	1	ARSS5
	208-230	3	ARSS7
	460	3	ARSS9
ARSS-LD	115	1	ARSSLD4
	208-230	1	ARSSLD5
	208-230	3	ARSSLD7
	460	3	ARSSLD9

DIMENSIONS

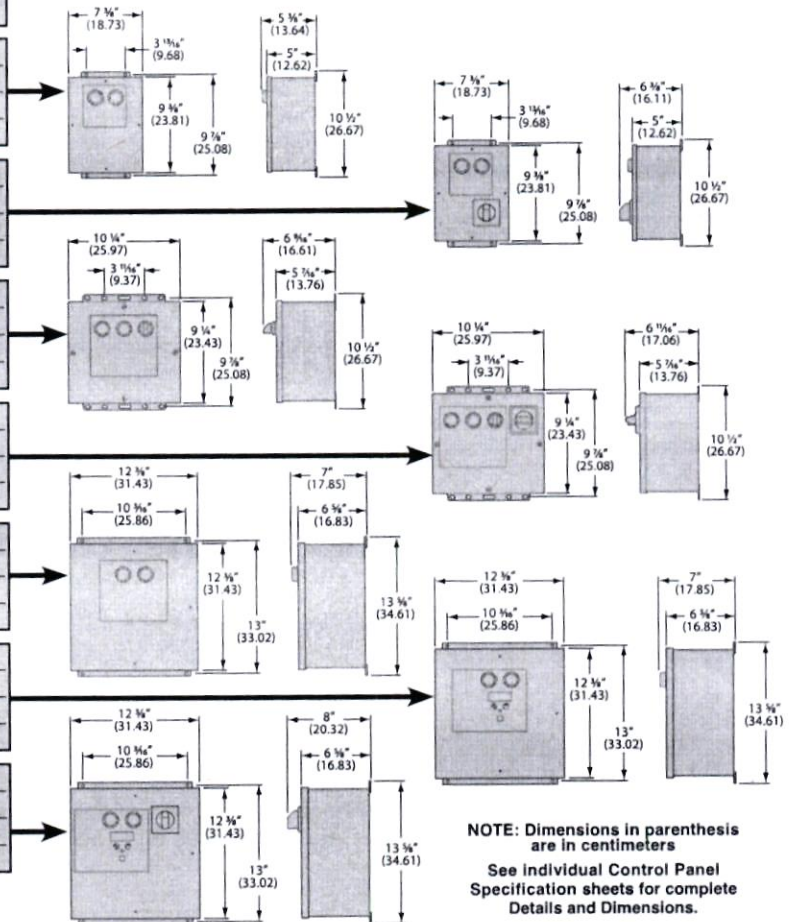

NOTE: Dimensions in parenthesis are in centimeters

See individual Control Panel Specification sheets for complete Details and Dimensions.

(Specifications subject to change without notice)

Current specification details may be found online at www.salvajor.com

◆ SPECIFY EXACT OPERATING VOLTAGE ◆

SALVAJOR.

Manufacturers of Commercial Food Waste Solutions - Since 1944

4530 East 75th Terrace Kansas City, MO 64132-2081, USA

816.363.1030 | Toll Free: 1.800.725.8256 | Service: 1.888.725.8256 | Fax: 1.800.832.9373

sales@salvajor.com | service@salvajor.com | www.salvajor.com

Printed in USA
Form No. CCP (05-18)

EZIQC SPECIFICATIONS AND CONTRACT DOCUMENTS

FOR

EZIQC-HCC-FM05430009579.00

RIVERSIDE UNIVERSITY HEALTH SYSTEM MEDICAL CENTER
KITCHEN DISHWASHER AND FLOORING REPLACEMENT PROJECT



PREPARED BY
COUNTY OF RIVERSIDE
FACILITIES MANAGEMENT
PROJECT MANAGEMENT OFFICE

TABLE OF CONTENTS

	Number of Pages
NJPA Membership Agreement	<u>1</u>
NJPA Indefinite Quantity Construction Agreement	<u>6</u>
EZIQC Work Order Signature Document	<u>3</u>
EZIQC Work Order Construction Contract - County & Contractor	<u>7</u>
Payment Bond	<u>5</u>
Performance Bond	<u>6</u>
Workers' Compensation Certificate	<u>1</u>
Certificate of Liability Insurance	<u>10</u>
Declaration of Sufficiency of Funds	<u>3</u>
Supplemental General Conditions of the Standard Form NJPA IQC-Work Order Contract (EZIQC) between County & Contractor (Includes Table of contents - 15 pages)	<u>129</u>
Plans and Specifications by Neyra Architect, Inc.	<u>SET</u>
Construction Task Catalog & Technical Specifications (CD)	<u>ON FILE WITH FM</u>

**MEMBERSHIP AGREEMENT
PARTICIPATING MEMBER**



This Agreement, made and entered into this 1 day of September, 2011,
by and between National Joint Powers Alliance®, hereinafter referred to as "NJPA" and
County of Riverside, CA hereinafter referred to as the "Applicant".

Witnesseth:

That for a good and valuable consideration of the premises, mutual terms, covenants, provisions, and conditions hereafter set forth, it is agreed by and between the parties as follows:

Whereas, the NJPA is created by Minnesota Statute §123A.21 (with membership further defined in M.S. §471.59) to serve cities, counties, towns, public or private schools, political subdivisions of Minnesota or another state, another state, any agency of the State of Minnesota or the United States including instrumentalities of a governmental unit and all non-profits; and

Whereas, NJPA's purpose as defined in M.S. §123A.21 is to assist in meeting specific needs of clients which could be better provided by NJPA than by the members themselves; and

Whereas, the NJPA Board of Directors has established the ability for an "Applicant" desiring to participate in NJPA contracts and procurement programs to become a Participating Member; and

Whereas, the NJPA Board of Directors has determined that Participating Members will have no financial or organizational liability to NJPA or to its organizational activities;

Now Therefore, it is hereby stipulated and agreed that the "Applicant" Agency desires to be a Participating Member of NJPA with contract purchasing benefits, in accordance with terms and conditions of the applicable contract(s), and that NJPA hereby grants said Membership to said "Applicant."

Term:

This continuing agreement shall remain in force or until either party elects to dissolve the Agreement by written notice.

THEREFORE, IN WITNESS THEREOF,

the parties hereto have executed this Agreement the day and year written above.

ECIA HARPER-IHEM, Clerk
3v
DEPUTY

Member Name:

By Bob Buster
AUTHORIZED SIGNATURE
BOB BUSTER
CHAIRMAN, BOARD OF SUPERVISORS
TITLE
OCT 18 2011
DATE

National Joint Powers Alliance®
200 1st Street NE, Suite 1
Staples, MN 56479

[Signature]
AUTHORIZED SIGNATURE
EXECUTIVE DIRECTOR
TITLE
9/1/11
DATE

FORM APPROVED COUNTY COUNSEL
BY [Signature]
NEAL R. KIPNIS
DATE 10/22/11

09/21/2010

OCT 18 2011 3:13



INDEFINITE QUANTITY CONSTRUCTION AGREEMENT

IFB NUMBER: CA-CR-GB01-062718

GEOGRAPHIC AREA: Region 8 – County of Riverside, California

This Agreement dated July 10, 2018, by and between Sourcewell (Formerly NJPA) and Horizons Construction Co. Int'l Inc. at the following address, 432 W. Meats Ave. Orange, CA 92865 hereinafter referred to as the CONTRACTOR.

WITNESSETH: Sourcewell and CONTRACTOR for the consideration hereafter agree as follows:

ARTICLE 1. CONTRACT DOCUMENTS

- A. Contract Documents: This Agreement; the IFB Documents; (Book 1 - Project Information, Instructions to Bidders and Execution Documents; Book 2 - IQCC Standard Terms and Conditions and General Conditions; Book 3 - Construction Task Catalog (CTC), Book 4 - Technical Specifications) and Addenda thereto, all payment and performance bonds (if any), material and workmanship bonds (if any); wage rate decisions and certified payroll records (if any); Notice of Award; all modifications issued thereto, including Supplemental Purchase Orders/Change Orders and written interpretations and all Purchase Orders and accompanying documents (Requests for Proposals, Detailed Scopes of Work, Purchase Order Proposals, etc.) issued hereunder.
- B. The terms and conditions of a Purchase Order issued by a Sourcewell Member in connection with any Project, including supplemental technical specifications referenced therein, shall govern.
- C. The Contractor shall, within two (2) business days of receipt of a Purchase Order from a Sourcewell Member, provide notification to Sourcewell or their designated representative of each Purchase Order by forwarding a copy of the Purchase Order via email to PO@EZIQC.com or via facsimile to (864) 233-9100.
- D. The Contractor shall, within two (2) business days of sending an Invoice to a Sourcewell Member, provide notification to Sourcewell or their designated representative of each Invoice by forwarding a copy of the Invoice via email to Invoice@EZIQC.com or via facsimile to (864) 233-9100.

ARTICLE 2. SCOPE OF WORK

- A. The Contractor shall provide the services required to develop each Purchase Order in accordance with the procedures for developing Purchase Orders set forth in the IQCC Standard Terms and Conditions and the Contract Documents.
- B. Each Purchase Order developed in accordance with this Agreement will be issued by an individual Sourcewell Member. The Purchase Order will require the Contractor to perform the Detailed Scope of Work within the Purchase Order Completion Time for the Purchase Order Price.
- C. It is anticipated that the Contractor will perform Work primarily in the Geographic Area set forth above. However, the parties may agree that the Contractor can perform Work in a different Geographic Area at its current Adjustment Factors.



ARTICLE 3. THE AGREEMENT PRICE

- A. This Agreement is an indefinite-quantity contract for construction work and services. The Estimated Annual Value of this Agreement is \$2,000,000. This is only an estimate and may increase or decrease at the discretion of Sourcewell.
- B. The Contractor shall perform any or all Tasks in the Construction Task Catalog for the Unit Price appearing therein multiplied by the following Adjustment Factors:

TO BE ENTERED BY SOURCEWELL:

- a. Normal Working Hours: Work performed from 7:00am until 4:00pm Monday to Friday, except holidays. Contractor shall perform Tasks during Normal Working Hours for the Unit Price set forth in the CTC multiplied by the Adjustment Factor of:

1.0162

(Specify to four (4) decimal places)

- b. Other Than Normal Working Hours: Work performed from 4:00pm to 7:00am Monday to Friday, and any time Saturday, Sunday and Holidays. Contractor shall perform Tasks during Other Than Normal Working Hours for the Unit Price set forth in the CTC multiplied by the Adjustment Factor of:

1.0486

(Specify to four (4) decimal places)

- c. Normal Working Hours OSHPD and Secured Areas: Work performed from 7:00am until 4:00pm Monday to Friday, except holidays. Contractor shall perform Tasks during Normal Working Hours for the Unit Price set forth in the CTC multiplied by the Adjustment Factor of:

1.0703

(Specify to four (4) decimal places)

- d. Other Than Normal Working Hours OSHPD and Secured Areas: Work performed from 4:00pm to 7:00am Monday to Friday, and any time Saturday, Sunday and Holidays. Contractor shall perform Tasks during Other Than Normal Working Hours for the Unit Price set forth in the CTC multiplied by the Adjustment Factor of:

1.1243

(Specify to four (4) decimal places)

- e. Non Pre-priced Adjustment Factor: To be applied to Work deemed not to be included in the CTC but within the general scope of the work:

1.2973

(Specify to four (4) decimal places)

ARTICLE 4. TERM OF THE AGREEMENT

- A. This Agreement has an initial term of one (1) year and a bilateral option provision for three (3) additional terms. The total term of the Agreement cannot exceed four (4) years. One additional one-year renewal-extension may be offered by Sourcewell to Contractor beyond the original three-year term if Sourcewell deems such action to be in the best interests of Sourcewell and its Members. The Contractor may withdraw from the Agreement on each anniversary of the award, provided that the Contractor gives 60 Days written notice of its intent to withdraw. Sourcewell may, for any reason, terminate this Agreement at any time.
- B. All Purchase Orders issued during a term of this Agreement shall be valid and in effect notwithstanding that the Detailed Scope of Work may be performed, payments may be made, and the guarantee period may continue, after such term has expired. All terms and conditions of the Agreement apply to each Purchase Order.

ARTICLE 5. SOFTWARE LICENSING

- A. Sourcewell selected The Gordian Group's (Gordian) software, data and services (IQCC System) for their IQCC program. The system includes Gordian's proprietary ezIQCC, eGordian and Bid Safe IQCC applications (IQCC Applications) and construction cost data (Construction Task Catalog), which shall be used by the Contractor to prepare and submit Price Proposals, subcontractor lists, and other requirements specified by Sourcewell and Sourcewell Members. The Contractor's use, in whole or in part, of Gordian's IQCC Applications and Construction Task Catalog and other proprietary materials provided by Gordian for any purpose other than to execute work under this Agreement for Sourcewell and Sourcewell Members is strictly prohibited unless otherwise stated in writing by Gordian. The Contractor hereby agrees to abide by the terms of the following IQCC System License:

ARTICLE 6. IQCC SYSTEM LICENSE

- A. Gordian hereby grants to the Contractor, and the Contractor hereby accepts from Gordian for the term of this Agreement or Gordian's contract with Sourcewell, whichever is shorter, a non-exclusive right, privilege, and license to Gordian's proprietary IQCC System and related proprietary materials (collectively referred to as "Proprietary Information") to be used for the sole purpose of executing Contractor's responsibilities to Sourcewell and Sourcewell Members under this Agreement ("Limited Purpose"). The Contractor hereby agrees that Proprietary Information shall include, but is not limited to, Gordian's IQCC Applications and support documentation, Construction Task Catalog, training materials, marketing materials and any other proprietary materials provided to Contractor by Gordian. In the event this Agreement expires or terminates as provided herein, or the Gordian's contract with Sourcewell expires or terminates, this IQCC System License shall terminate and the Contractor shall return all Proprietary Information in its possession to Gordian.
- B. Contractor acknowledges that Gordian shall retain exclusive ownership of all proprietary rights to the Proprietary Information, including all U.S. and international intellectual property and other rights such as patents, trademarks, copyrights and trade secrets. Contractor shall have no right or interest in any portion of the Proprietary Information except the right to use the Proprietary Information for the Limited Purpose set forth herein. Except in furtherance of the



Limited Purpose, Contractor shall not distribute, disclose, copy, reproduce, display, publish, transmit, assign, sublicense, transfer, provide access to, use or sell, directly or indirectly (including in electronic form), any portion of the Proprietary Information.

- C. Contractor acknowledges and agrees to respect the copyrights, trademarks, trade secrets, and other proprietary rights of Gordian in the Proprietary Information during and after the term of this Agreement, and shall at all times maintain complete confidentiality with regard to the Proprietary Information provided to Contractor, subject to federal, state and local laws related to public disclosure. Contractor further acknowledges that a breach of any of the terms of this Agreement by Contractor will result in irreparable harm to Gordian for which monetary damages would be an inadequate remedy, and Gordian shall be entitled to injunctive relief (without the necessity of posting a bond) as well as all other monetary remedies available at law or in equity. In the event that it becomes necessary for either party to this IQCC System License to enforce the provisions of this Agreement or to obtain redress for the breach or violation of any of its provisions, whether by litigation, arbitration or other proceedings, the prevailing party shall be entitled to recover from the other party all costs and expenses associated with such proceedings, including reasonable attorney's fees.
- D. In the event of a conflict in terms and conditions between this IQCC System License and any other terms and conditions of this Agreement or any Purchase Order, Order or similar purchasing document (Purchase Order) issued by Sourcewell or a Sourcewell Member, this IQCC System License shall take precedence.

IN WITNESS WHEREOF, the parties hereto have executed this Agreement the day and year first above written.

By:

Sourcewell

DocuSigned by:

 76144D620E084E3...
 Authorized Signature

Jeremy Schwartz, Director of Operations &
Procurement/CPO
 Print Name

Contractor – Horizons Construction Co. Int'l Inc.

DocuSigned by:

 441BA91F6DAD4E0...
 Authorized Signature

Kinan Kotrash, V. President
 Print Name

Contract Number: CA-CR-GB01-062718-HCC (assigned by Sourcewell)

ANNUAL RENEWAL AND MODIFICATION OF AGREEMENT
made by and between

Horizons Construction Co. Int'l, Inc.
432 W. Meats Ave.
Orange, CA 92865

and

Sourcewell
202 12th Street NE
PO Box 219
Staples, MN 56479
Phone: (218) 894-1930 or (888) 894-1930

Whereas: "Vendor" and "Sourcewell" have entered into 1) an "Acceptance of Bid and IFB CA-CR-GB01-062718-HCC" with an effective date of July 10, 2018, a maturity date of July 9, 2022, and which are subject to annual renewals at the option of both parties.

MODIFICATION: FIRST RENEWAL OPTION PERIOD

Pursuant to the agreement between the parties, the following are the Adjustment Factors for the next option period:

Base Year		
	Date	Index
1	June 2017	10707.81
2	July 2017	10789.26
3	August 2017	10841.56
4	September 2017	10822.82
5	October 2017	10817.11
6	November 2017	10870.06
7	December 2017	10873.56
8	January 2018	10878.01
9	February 2018	10889.17
10	March 2018	10958.79
11	April 2018	10971.91
12	May 2018	11012.77

Base Average
10869.4025

Option Year		
	Date	Index
1	June 2018	11067.00
2	July 2018	11116.07
3	August 2018	11124.49
4	September 2018	11169.87
5	October 2018	11169.68
6	November 2018	11183.93
7	December 2018	11185.44
8	January 2019	11205.73
9	February 2019	11217.90
10	March 2019	11227.88
11	April 2019	11228.07
12	May 2019	11229.99

Option Average
11177.1708

Price Adjustment: **First Year Index Average** = $\frac{11177.1708}{10869.4025}$ = **1.0283**
Base Year Index Average

	AWARD MULTIPLIER	x	PRICE ADJUSTMENT	=	OPTION MULTIPLIER
# CA-CR-GB01-062718-HCC					
Non Pre-Priced	1.2973		1.0000		1.2973
Normal Working Hours	1.0162		1.0283		1.0450
Normal Working Hours OSHPD and Secured Areas	1.0703		1.0283		1.1006
Other Than Normal Working Hours	1.0486		1.0283		1.0783
Other Than Normal Working Hours OSHPD and Secured Areas	1.1243		1.0283		1.1561

Now therefore:

"Vendor" and "Sourcewell" hereby desire and agree to extend and renew the above defined contracts and with the above identified modifications for the period of July 10, 2019 through July 9, 2020.

Sourcewell

By:  , Its: Director of Cooperative Contracts and Procurement/CPO
 Name printed or typed: Jeremy Schwartz
 Date: 5/22/2019 | 9:38 PM CDT

Horizons Construction Co. Int'l, Inc. - #CA-CR-GB01-062718-HCC

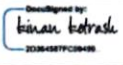
By:  , Its: V. President
 Name printed or typed: Kinan Kotrash
 Date: 5/22/2019 | 5:37 PM CDT

 If you do not want to extend contract, please sign below and return this agreement.
Discontinue: We desire to discontinue the contract.

Signature: _____, Date: _____

Work Order Signature Document

EZIQC Contract No.: CA-CR-GB01-062718-HCC	
<input checked="" type="checkbox"/> New Work Order	<input type="checkbox"/> Modify an Existing Work Order
Work Order Number.: ezIQC-HCC-FM05430009579.00	Work Order Date: <u>08/09/2021</u>
Work Order Title: <u>RUHS MC Kitchen Dishwasher & Flooring Replacement</u>	
Owner Name: <u>County of Riverside Facilities Mgmt.</u>	Contractor Name: <u>Horizons Construction Co. Int'l, Inc.</u>
Contact: <u>Nahid Selbe</u>	Contact: <u>Kinan Kotrash</u>
Phone: <u>(951) 955-4728</u>	Phone: <u>(714) 626-0000</u>
Work to be Performed	
Work to be performed as per the Final Detailed Scope of Work Attached and as per the terms and conditions of Sourcewell EZIQC Contract No CA-CR-GB01-062718-HCC.	
<u>Brief Work Order Description:</u>	
Replace existing kitchen dishwasher. Provide electrical and plumbing to new dishwasher. Provide anchorage. Provide new exhaust.	
Time of Performance	Estimated Start Date: 09/22/2021 Estimated Completion Date: 12/29/2021
Liquidated Damages	Will apply: <input checked="" type="checkbox"/> Will not apply: <input type="checkbox"/>
Work Order Firm Fixed Price: \$155,175.75	
Owner Purchase Order Number: ezIQC-HCC-FM05430009579.00	

Approvals

Nahid N. Selbe 8/11/2021
County of Riverside Facilities Mgmt. Date

 08/12/2021
Contractor Kinan Kotrash, V. President Date

Detailed Scope of Work

To: Kinan Kotrash
Horizons Construction Co. Int'l, Inc.
432 W. Meats Ave.
Orange, CA 92865
(714) 626-0000

From: Nahid Selbe
County of Riverside Facilities Mgmt.
3133 Mission Inn Avenue
Riverside, CA 92507
(951) 955-4728

Date Printed: August 09, 2021

Work Order Number: ezIQC-HCC-FM05430009579.00

Work Order Title: RUHS MC Kitchen Dishwasher & Flooring Replacement

Brief Scope: Replace existing kitchen dishwasher. Provide electrical and plumbing to new dishwasher. Provide anchorage. Provide new exhaust.

Preliminary

Revised

Final

The following items detail the scope of work as discussed at the site. All requirements necessary to accomplish the items set forth below shall be considered part of this scope of work.

094940.00 – RUHS Medical Center – Dishwasher Replacement

Detailed Scope of Work

- Replace Existing Kitchen Dishwasher
- Furnish and Install (1) Single Kitchen Sink and (1) Three Compartment Sink
- Provide and Electrical and Plumbing to new Dishwasher.
- Provide anchorage for New Dishwasher Units.
- Provide new Duct work as shown on M2.2
- Furnish and Install New Duct Insulation as shown on Mechacial Specifications.
- Furnish and Install new Hangers as shown on plans.
- Provide new exhaust fans and new fan coil unit.
- Demo Existing Flooring and Replace flooring as shown on A2.0
- Demo Existing Ceiling and Replace as shown on A2.0
- Provide and Install New Electrical Cabling and Conduits as shown on E3.2
- Provide all Piping and Supports as shown on P2.2

Subject to the terms and conditions of JOC Contract CA-CR-GB01-062718-HCC.



Contractor Kinan Kotrash, V. President

08/12/2021
Date

Nahid N. Selbe

County of Riverside Facilities Mgmt.

8/12/2021
Date

Contractor's Price Proposal - Summary

Date: August 09, 2021

Re: IQC Master Contract #: CA-CR-GB01-062718-HCC
Work Order #: ezIQC-HCC-FM05430009579.00
Owner PO #: ezIQC-HCC-FM05430009579.00
Title: RUHS MC Kitchen Dishwasher & Flooring Replacement
Contractor: Horizons Construction Co. Int'l, Inc.
Proposal Value: \$155,175.75

Electrical	\$26,250.91
Finishes	\$24,625.31
General	\$15,969.84
Mechanical	\$63,465.52
Plumbing	\$24,864.17
Proposal Total	\$155,175.75

This total represents the correct total for the proposal. Any discrepancy between line totals, sub-totals and the proposal total is due to rounding.

The Percentage of NPP on this Proposal: %



**EZIQC WORK ORDER
CONSTRUCTION CONTRACT
BETWEEN COUNTY AND CONTRACTOR**

by and between

HORIZONS CONSTRUCTION COMPANY INTERNATIONAL, INC.

(the "Contractor")

And

THE COUNTY OF RIVERSIDE

(the "County")

FOR:

**RIVERSIDE UNIVERSITY HEALTH SYSTEM MEDICAL CENTER
KITCHEN DISHWASHER AND FLOORING REPLACEMENT PROJECT
EZIQC-HCC-FM05430009579**

LOCATED AT:

26520 CACTUS AVENUE, MORENO VALLEY, CA 92555

EZIQC WORK ORDER CONSTRUCTION CONTRACT FOR EZIQC
BETWEEN COUNTY AND CONTRACTOR

THIS EZIQC WORK ORDER CONSTRUCTION CONTRACT BETWEEN COUNTY AND CONTRACTOR ("Work Order Agreement") is entered into as of the date of the last signature on the signature page of this contract, by and between THE COUNTY OF RIVERSIDE, a political subdivision of the State of California ("County") and HORIZONS CONSTRUCTION COMPANY INTERNATIONAL, INC., a CALIFORNIA CORPORATION ("Contractor"), whose principal place of business is located at 432 West Meats Avenue, Orange, CA 92865.

ARTICLE 1
DEFINITIONS

Capitalized terms used in the Contract Documents shall have the meanings assigned to them in the Supplementary General Conditions. If not defined in the Supplementary General Conditions, they shall have the meanings assigned to them elsewhere in the Contract Documents. If not defined in the Supplementary General Conditions or elsewhere, they shall have the meanings reasonably understood to apply to them by the context in which they are used.

ARTICLE 2
PERFORMANCE OF WORK

2.1 SCOPE OF WORK

Contractor shall execute the entire Work called for by the Contract Documents, except to the extent specifically indicated in the Contract Documents to be the responsibility of others.

2.2 STANDARD OF PERFORMANCE

In addition to and without limiting Contractor's other obligations under the Contract Documents, Contractor shall at all times in its performance of its obligations under the Contract Documents conform to the following general standards of performance:

2.2.1 the requirements of the Contract Documents;

2.2.2 the requirements and conditions of Applicable Laws;

2.2.3 the standard of care applicable to those who provide construction of the type called for by this Construction Contract for projects of a scope and complexity comparable to the Project;

2.2.4 Contractor shall furnish efficient business administration of the Work, utilizing sufficient senior level management and other qualified personnel to manage the Work; and

2.2.5 Contractor shall apply its best and highest skill and attention to completing the Work in an expeditious and economical manner, consistent with the expressed best interests of the County and within the limitations of the Contract Price and Contract Time.

**ARTICLE 3
CONTRACT TIME**

3.1 CONTRACT TIME

3.1.1 Substantial Completion. Subject to Contract Adjustments permitted by the Contract Documents, Contractor shall achieve Substantial Completion of the entire Work not later than Ninety (90) Days after the Date of Commencement.

3.1.2 Final Completion. Subject to Contract Adjustments permitted by the Contract Documents, Contractor shall achieve Final Completion of the Work not later than Thirty (30) Calendar Days after the actual occurrence of Substantial Completion.

3.1.3 Contract Adjustments. The Contract Time shall be extended or shortened only in accordance with the provisions of the Contract Documents governing Contract Adjustments to the Contract Time.

3.2 LIQUIDATED DAMAGES TO COUNTY

3.2.1 County's Right. County and Contractor acknowledge that if Contractor fails to Substantially Complete the Work within the Contract Time for Substantial Completion, County will suffer substantial Losses, which would be both extremely difficult and impracticable to ascertain. On that basis they agree, as a reasonable estimate of those Losses and not a penalty, to the assessment and recovery by County of liquidated damages under this Section 3.2.

3.2.2 Per Diem Rate. If Contractor fails to actually achieve Substantial Completion of the entire Work within the Contract Time for Substantial Completion, Contractor shall pay to County as liquidated damages the amount of One Thousand Dollars (\$1,000) per Day for each Day occurring after the expiration of the Contract Time for Substantial Completion until Contractor achieves Substantial Completion of the entire Work.

3.2.3 Adjustment for Extensions of Time. Subject to the provisions of Paragraph 8.2.8 of the Supplementary General Conditions dealing with concurrency of Delays, liquidated damages shall not be charged to Contractor for a period of time for which the Contractor is entitled under the Contract Documents to a Contract Adjustment to the Contract Time for Substantial Completion.

3.2.4 Partial Completion. The liquidated damages provided for under this Section 3.2 shall not be reduced or apportioned: (1) for Substantial Completion of portions of the Work prior to Substantial Completion of the entirety of the Work; or (2) if portions of the Work are deleted pursuant to (a) the County's right to order Deleted Work; or (b) a termination by County of a portion of the Construction Contract or a deletion of portion of Work for the convenience of the County or due to an Event of Contractor Default.

3.2.5 Remedies. County may deduct any liquidated damages payable under this Section 3.2 from money due or to become due to Contractor under the Contract Documents, or pursue any other legal remedy to collect such liquidated damages from Contractor and/or its Surety.

3.2.6 Not a Limitation. County's rights under this Section 3.2 shall not be interpreted as precluding or limiting: (1) any right or remedy of County arising from an Event of Contractor Default other than a failure to achieve Substantial Completion of the Work within the Contract Time for Substantial Completion; or (2) County's right to order an acceleration, at Contractor's Own Expense, of performance of the Work to overcome Delay, including, without limitation, a Delay for which County has the right to assess liquidated damages under this Section 3.2.

3.3 LIQUIDATED DAMAGES TO CONTRACTOR

3.3.1 Contractor's Right. County and Contractor acknowledge and agree that if Contractor is unable due to Compensable Delay to actually achieve Substantial Completion of the Work within the Contract Time for Substantial Completion, Contractor and its affected Subcontractors will suffer Losses that would be both extremely difficult and

impracticable to ascertain. On that basis they agree, as a reasonable estimate of those Losses and not a penalty, to the payment by County to Contractor of liquidated damages under this Section 3.3.

3.3.2 Daily Rate. Subject to the provisions of Paragraph 8.2.8 of the Supplementary General Conditions dealing with concurrency of Delays, the Contract Price shall be increased by Change Order or Unilateral Change Order in the amount of Five Hundred Dollars (\$500) per Day as liquidated damages for each Day for which Contractor is entitled under the Contract Documents to a Contract Adjustment extending the Contract Time for Substantial Completion due to Compensable Delay, with no additional amount added thereto or calculated thereon for Allowable Markup or any other markup for overhead or profit to Contractor or any Subcontractor, of any Tier.

3.3.3 Payment by County. A Change Order or Unilateral Change Order setting forth a Contract Adjustment to the Contract Price for liquidated damages permitted by this Section 3.3 shall be executed following, and not before, actual Substantial Completion and prior to or contemporaneously with Final Completion. Notwithstanding any other provision of the Contract Documents to the contrary and without limitation to the County's rights of withholding payment to Contractor as permitted elsewhere in the Contract Documents or under Applicable Laws, any amounts due to the Contractor under this Section 3.3 shall be payable as part of, and not prior to the due date for payment of, Final Payment to Contractor.

3.3.4 Deleted Work. A Contract Adjustment shall be made pursuant to Subparagraph 8.2.6.2 of the Supplementary General Conditions reducing the Contract Price and Contract Time in the event that the Contract Time is shortened due to (1) Deleted Work; or (2) a termination by County of a portion of the Construction Contract for convenience or due to an Event of Contractor Default.

3.3.5 Termination. County shall have no liability to Contractor to pay any liquidated damages under this Section 3.3, nor shall County have any other liability to Contractor or any Subcontractor for any Loss due to Delay (including, without limitation, Compensable Delay) in the event the Construction Contract is wholly terminated (whether such termination is a termination for cause by County or Contractor or a termination for convenience by County) at any time prior to expiration of the Contract Time for Substantial Completion set forth in Paragraph 3.1.1, above.

3.3.6 Exclusive Remedy. Liquidated damages payable by County under this Section 3.3 constitute the Contractor's sole and exclusive right and remedy for recovery from County of Losses to Contractor and its Subcontractors, of every Tier, that are attributable to Compensable Delay, regardless of the cause, duration or timing of the Compensable Delay and no other Contract Adjustment, or other form of compensation or reimbursement, of any kind, shall be made to Contractor or any Subcontractor, of any Tier, for any Loss resulting, directly or indirectly, from, or attributable to, any of the following: (1) Unexcused Delay or acceleration to overcome Unexcused Delay; (2) Excusable Delay or any acceleration not authorized by County in writing to overcome Excusable Delay; or (3) concurrency of a Compensable Delay with any different type or class of Unexcused Delay or Excusable Delay, whether such concurrency is a concurrency in cause or in effect.

3.3.7 WAIVER BY CONTRACTOR.

CONTRACTOR WAIVES THE RIGHT TO FURTHER RECOURSE OR RECOVERY OF COSTS OR DAMAGES BY REASON OF OR RELATED TO ANY DELAY (INCLUDING, WITHOUT LIMITATION, COMPENSABLE DELAY) THAT IS IN EXCESS OF OR NOT RECOVERED BY CONTRACTOR AS PART OF THE LIQUIDATED DAMAGES PAYABLE TO CONTRACTOR UNDER THIS SECTION 3.3.

**ARTICLE 4
CONTRACTOR COMPENSATION**

4.1 CONTRACT PRICE

4.1.1 Contract Price. County shall pay the Contractor in current funds for the Contractor's performance of the Work in accordance with the Contract Documents the Contract Price, exclusive of Contract Adjustments, of **One Hundred Fifty-Five Thousand One Hundred Seventy-Six Dollars (\$155,176)**.

4.1.2 Basis. The Contract Price set forth in Paragraph 4.1.1, above, is based on the Work Order submitted by Contractor and accepted by County as set forth in Section 4.2, below. This Work Order Agreement is the Purchase Order issued by an NJPA member as referenced in the Indefinite Quantity Construction Agreement between the Contractor and

NJPA; and, as that document states, any Purchase Order issued by an NJPA member including terms and conditions and supplemental specs shall govern.

4.1.3 Adjustments. The Contract Price is only subject to adjustment as permitted by the Supplementary General Conditions for Contract Adjustments due to Compensable Changes, Deleted Work or Compensable Delay.

4.1.4 All-Inclusive Price. The Contract Price as adjusted for Contract Adjustment permitted by the Contract Documents is the total amount payable by County to Contractor for performance of the Work under the Contract Documents and is deemed to cover all Losses, foreseeable or unforeseeable, arising out of or related to past, present or future circumstances within or outside the control of the Contractor or its Subcontractors affecting the time or cost of performing the Work, including, without limitation, the effects of natural elements upon the Work, unforeseen difficulties or obstructions affecting the performance of the Work (including, without limitation, unforeseen conditions at the Site that do not constitute Differing Site Conditions) and unforeseen fluctuations in market conditions and price escalations (whether occurring locally, nationally or internationally).

4.2 WORK ORDER

The Contract Price includes the following Work Order, which are described in the Contract Documents and are hereby accepted by County:

Number	Description	Dollar Amount
ezIQC-(HHC-M05430009579.00)	RUHS-MC Kitchen Dishwasher & Flooring Replacement Project	\$155,176

4.3 UNIT PRICES

Unit prices agreed to by County and Contractor are as follows:

Description	Measurement Unit	Dollar Amount
N/A	N/A	N/A

**ARTICLE 5
ENUMERATION OF CONTRACT DOCUMENTS**

5.1 LIST OF CONTRACT DOCUMENTS

The Contract Documents include, without limitation, the following:

5.1.1 Construction Contract. The Contract Documents include this executed EZIQC Work Order Construction Contract Between County and Contractor.

5.1.2 General Conditions. The Contract Documents include the NJPA IQCC Standard Terms and Conditions and Contract General Conditions (Book 2), Supplementary General Conditions of the Standard Form of Construction Contract for EZIQC Between County and Contractor (Long Form) or Supplementary General Conditions of the Work Order Construction Contract Between County and Contractor (Short Form).

5.1.3 Specifications. The Contract Documents include the following Specifications:

Title	Date	Divisions
N/A	date	text

5.1.4 Drawings. The Contract Documents include the following Drawings dated April 8, 2021, unless a different date is shown below:

Sheet Number	Title	Date	Pages
All Sheets	Kitchen Dishwasher Replacement	04/08/2021	38

5.1.5 Also incorporated herein are:

- 5.1.5.1. NJPA Membership Agreement (executed)
- 5.1.5.2. NJPA Indefinite Quantity Construction Agreement
- 5.1.5.3. EZIQC Work Order Signature Document

**ARTICLE 6
SPECIAL REQUIREMENTS**

6.1 LABOR CODE SECTION 1861 CERTIFICATION

By signing below, Contractor certifies that he/she/it is aware of the provisions of Section 3700 of the California Labor Code which require every employer to be insured against liability for Worker's Compensation or to undertake self-insurance in accordance with the provisions of the California Labor Code, and that he/she/it will comply with such provisions before commencing the performance of the Work.

CONTRACTORS ARE REQUIRED BY LAW TO BE LICENSED AND REGULATED BY THE CONTRACTORS' STATE LICENSE BOARD WHICH HAS JURISDICTION TO INVESTIGATE COMPLAINTS AGAINST CONTRACTORS IF A COMPLAINT REGARDING A PATENT ACT OR OMISSION IS FILED WITHIN FOUR YEARS OF THE DATE OF THE ALLEGED VIOLATION. A COMPLAINT REGARDING A LATENT ACT OR OMISSION PERTAINING TO STRUCTURAL DEFECTS MUST BE FILED WITHIN 10 YEARS OF THE DATE OF THE ALLEGED VIOLATION. ANY QUESTIONS CONCERNING A CONTRACTOR MAY BE REFERRED TO THE REGISTRAR, CONTRACTORS' STATE LICENSE BOARD, P.O. BOX 26000, SACRAMENTO, CALIFORNIA, 95826.

IN WITNESS WHEREOF, the parties hereto have made and executed three (3) originals of this Construction Contract, on _____ [to be filled in by Clerk of the Board].

[SIGNATURES ON FOLLOWING PAGE

"COUNTY"

COUNTY OF RIVERSIDE

By: Karen S. Spiegel Dated _____
Chair, Board of Supervisors

ATTEST:

KECIA R. HARPER
Clerk of the Board

By: [Signature] Dated 11/2/2021
Deputy

(SEAL)

APPROVED AS TO FORM:

GREGORY P. PRIAMOS
County Counsel

By: [Signature] Dated 9/21/2021
K. Bell Valdez
Deputy County Counsel

"CONTRACTOR"

Horizons Construction Company International, Inc.

(sign on line above)

By: Kinan Kotrash
(type name)

Title: V. President & Secretary

The following information must be provided concerning the Contractor:

State whether Contractor is corporation, individual, partnership, joint venture or other: Corporation

If "other", enter legal form of business: _____

Enter address: 432 W. Meats Ave.
Orange, CA 92865

Telephone: 714-626-0000
Facsimile: 714-626-0006
Email: kinan@horizonscci.com

Employer State _____
Tax ID #: 14-1865687

State Contractor License #: 825022

DIR Registration #: 1000011017

If Contractor is not an individual or corporation, list names of 4 representatives who have authority to contractually bind Contractor:

If Contractor is a corporation, state:
Name of President: Hatem Ibrahim
Name of Secretary: Kinan Kotrash
State of Incorporation: CA

CALIFORNIA ALL-PURPOSE ACKNOWLEDGMENT

A notary public or other offices completing this certificate verifies only the identity of the Individual who signed the document to which this certificate is attached, and not the truthfulness, accuracy, or validity of that document.

State of CALIFORNIA

County of ORANGE

On August 30, 2021 before me YAZMIN BARRERA VALDES, NOTARY PUBLIC

Personally appeared KINAN KOTRASH

who proved to me on the basis of satisfactory evidence to be the person(s) whose name(s) is/are subscribed to the within instrument and acknowledged to me that he/~~she~~/they executed the same in his/~~her~~/their authorized capacity (ies), and that by his/~~her~~/their signature(s) on the instrument the person(s), or the entity upon behalf of which the person(s) acted, executed the instrument.

I certify under PENALTY OF PERJURY under the laws of the State of California that the foregoing paragraph is true and correct.

WITNESS my hand and official seal.

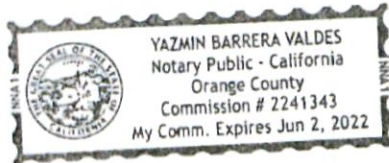

Yazmin Barrera Valdes
Signature of Notary

OPTIONAL

Though the data below is not required by law, it may prove valuable to persons relying on the document and could prevent fraudulent reattachment of this form.

CAPACITY CLAIMED BY SIGNER	DESCRIPTION OF ATTACHED DOCUMENT
<input type="checkbox"/> INDIVIDUAL	EZIQC-HCC-FM05430009575
<input checked="" type="checkbox"/> CORPORATE OFFICER	Contract
<input type="checkbox"/> LIMITED	
<input type="checkbox"/> PARTNER(S)	
<input type="checkbox"/> ATTORNEY-IN-FACT	
<input type="checkbox"/> TRUSTEE(S)	
<input type="checkbox"/> GUARDIAN/CONSERVATOR	
<input type="checkbox"/> OTHER: _____	
SIGNER IS REPRESENTING:	Horizons Construction Co. Int'l, Inc.
NAME OF PERSON(S) OR ENTITY (IES)	

Bond No.: WCN 5951504

*** In Triplicate ***

Bond No. EZIQC-HHC-FM05430009579.00

PAYMENT BOND

(Public Work - Civil Code Sections 9550 et seq.)

KNOW ALL PERSONS BY THESE PRESENTS:

THAT WHEREAS, the County of Riverside ("County") by action of the Board of Supervisors has awarded Construction Contract Number EZIQC-HHC-FM05430009579.00 ("Contract") to **HORIZONS CONSTRUCTION COMPANY INTERNATIONAL, INC.** as Principal ("Principal") to perform the work ("Work") for the **Kitchen Dishwasher and Flooring Replacement project**;

AND, WHEREAS, said Principal is required by the Contract and/or by Division 3, Part IV, Title XV, Chapter 7 (commencing at Section 9550) of the California Civil Code to furnish a payment bond in connection with the Contract;

Old Republic

NOW THEREFORE, we, the Principal and Old Republic Surety Company ("Surety"), an admitted surety insurer pursuant to Code of Civil Procedure, Section 995.120, are held and firmly bound unto County in the penal sum of One Hundred Fifty-Five Thousand, One Hundred Seventy-Six and 00/100 Dollars (\$155,176.00), this amount being not less than one hundred percent (100%) of the total sum payable by County under the Contract at the time the Contract is awarded by County to the Principal, lawful money of the United States of America, for the payment of which sum well and truly to be made, we, Principal and Surety, bind ourselves, our heirs, executors, administrators, successors and assigns, jointly and severally, firmly by these presents.

THE CONDITION OF THIS OBLIGATION IS SUCH that if Principal, its heirs, executors, administrators, successors, or assigns approved by County, or its subcontractors, of any contracting tier, shall fail to pay any person or persons named in California Civil Code, Section 9554, then Surety will pay for the same, in or to an amount not exceeding the penal amount hereinabove set forth, and also will pay to the prevailing party if suit is brought upon this bond, reasonable attorney's fees as provided in California Civil Code, Section 9564.

Surety, for value received, agrees that no change, extension of time, alteration or addition to the terms of the Contract, or to the Work to be performed thereunder, nor any rescission or attempted rescission of the Contract or this bond, nor any conditions precedent or subsequent in the bond or Contract attempting to limit the right of recovery of any claimant otherwise entitled to recover under the Contract or this bond shall in any way impair or affect Surety's obligation under this bond, and Surety does hereby waive notice of any such changes, extensions of time, alterations or additions.

Surety is not released from liability to those for whose benefit this bond has been given, by reason of

any breach of the Contract by County or Principal.

Surety's obligations hereunder are independent of the obligations of any other surety for the performance of the Contract, and suit may be brought against Surety and such other sureties, joint and severally, or against any one or more of them or against less than all of them, without impairing County's rights against the others.

Horizons Construction Company International, Inc.
(Firm Name – Principal)

Affix Seal if Corporation

432 Meats Avenue
Orange, CA 92865

(Business Address)

By 

(Original Signature)

V. President / Secretary
(Title)

Old Republic Surety Company
(Corporation Name – Surety)

Affix Corporate Seal

14728 Pipeline Avenue, Suite E
Chino Hills, CA 91709

(Business Address)

By 

(Signature – Attached Notary's Acknowledgment)

Randy Spohn

ATTORNEY-IN-FACT

(Title-Attach Power of Attorney)

Note: Notary acknowledgment of signatures of Contractor and Surety, and Surety's Power of Attorney, must be included or attached



OLD REPUBLIC SURETY COMPANY

POWER OF ATTORNEY

KNOW ALL MEN BY THESE PRESENTS: That OLD REPUBLIC SURETY COMPANY, a Wisconsin stock insurance corporation, does make, constitute and appoint:

Randy Spohn, Matthew R. Dobyns, Ashley M. Spohn of Santa Ana, CA

its true and lawful Attorney(s)-in-Fact, with full power and authority for and on behalf of the company as surety, to execute and deliver and affix the seal of the company thereto (if a seal is required), bonds, undertakings, recognizances or other written obligations in the nature thereof, (other than bail bonds, bank depository bonds, mortgage deficiency bonds, mortgage guaranty bonds, guarantees of installment paper and note guaranty bonds, self-insurance workers compensation bonds guaranteeing payment of benefits, or black lung bonds), as follows:

ALL WRITTEN INSTRUMENTS

and to bind OLD REPUBLIC SURETY COMPANY thereby, and all of the acts of said Attorneys-in-Fact, pursuant to these presents, are ratified and confirmed. This appointment is made under and by authority of the board of directors at a special meeting held on February 18, 1982.

This Power of Attorney is signed and sealed by facsimile under and by the authority of the following resolutions adopted by the board of directors of the OLD REPUBLIC SURETY COMPANY on February 18, 1982.

RESOLVED that, the president, any vice-president or assistant vice president, in conjunction with the secretary or any assistant secretary, may appoint attorneys-in-fact or agents with authority as defined or limited in the instrument evidencing the appointment in each case, for and on behalf of the company to execute and deliver and affix the seal of the company to bonds, undertakings, recognizances, and suretyship obligations of all kinds; and said officers may remove any such attorney-in-fact or agent and revoke any Power of Attorney previously granted to such person.

RESOLVED FURTHER, that any bond, undertaking, recognizance, or suretyship obligation shall be valid and binding upon the Company

- (i) when signed by the president, any vice president or assistant vice president, and attested and sealed (if a seal be required) by any secretary or assistant secretary; or
- (ii) when signed by the president, any vice president or assistant vice president, secretary or assistant secretary, and countersigned and sealed (if a seal be required) by a duly authorized attorney-in-fact or agent; or
- (iii) when duly executed and sealed (if a seal be required) by one or more attorneys-in-fact or agents pursuant to and within the limits of the authority evidenced by the Power of Attorney issued by the company to such person or persons.

RESOLVED FURTHER that the signature of any authorized officer and the seal of the company may be affixed by facsimile to any Power of Attorney or certification thereof authorizing the execution and delivery of any bond, undertaking, recognizance, or other suretyship obligations of the company; and such signature and seal when so used shall have the same force and effect as though manually affixed.

IN WITNESS WHEREOF, OLD REPUBLIC SURETY COMPANY has caused these presents to be signed by its proper officer, and its corporate seal to be affixed this 18th day of May, 2021.

Karen J. Haffner
Assistant Secretary



OLD REPUBLIC SURETY COMPANY

Alan Pavlic
President

STATE OF WISCONSIN, COUNTY OF WAUKESHA - SS

On this 18th day of May, 2021, personally came before me, Alan Pavlic and Karen J Haffner, to me known to be the individuals and officers of the OLD REPUBLIC SURETY COMPANY who executed the above instrument, and they each acknowledged the execution of the same, and being by me duly sworn, did severally depose and say: that they are the said officers of the corporation aforesaid, and that the seal affixed to the above instrument is the seal of the corporation, and that said corporate seal and their signatures as such officers were duly affixed and subscribed to the said instrument by the authority of the board of directors of said corporation.



Kathryn R. Pearson
Notary Public

My Commission Expires: September 28, 2022

(Expiration of notary's commission does not invalidate this instrument)

CERTIFICATE

I, the undersigned, assistant secretary of the OLD REPUBLIC SURETY COMPANY, a Wisconsin corporation, CERTIFY that the foregoing and attached Power of Attorney remains in full force and has not been revoked; and furthermore, that the Resolutions of the board of directors set forth in the Power of Attorney, are now in force.

74 7097



Signed and sealed at the City of Brookfield, WI this 25th day of August, 2021.

Karen J. Haffner
Assistant Secretary

ORSC 22262 (3-06)

R.S. Bonding & Ins. Agency Inc

CALIFORNIA ALL-PURPOSE ACKNOWLEDGMENT

A notary public or other officer completing this certificate verifies only the identity of the individual who signed the document to which this certificate is attached, and not the truthfulness, accuracy, or validity of that document.

State of CALIFORNIA

County of ORANGE

On 8/25/2021 before me, ERIKA G. MORGAN, NOTARY PUBLIC,

personally appeared RANDY SPOHN

who proved to me on the basis of satisfactory evidence to be the person(s) whose name(s) is/are subscribed to the within instrument and acknowledged to me that he/she/they executed the same in his/her/their authorized capacity (ies), and that by his/her/their signature(s) on the instrument the person(s), or the entity upon behalf of which the person(s) acted, executed the instrument.

I certify under PENALTY OF PERJURY under the laws of the State of California that the foregoing paragraph is true and correct.

WITNESS my hand and official seal.



Erika G. Morgan
Signature of Notary

OPTIONAL

Though the data below is not required by law, it may prove valuable to persons relying on the document and could prevent fraudulent reattachment of this form.

CAPACITY CLAIMED BY SIGNER	DESCRIPTION OF ATTACHED DOCUMENT
<input type="checkbox"/> INDIVIDUAL	_____
<input type="checkbox"/> CORPORATE OFFICER	_____
<input type="checkbox"/> PARTNER(S)	_____
<input checked="" type="checkbox"/> ATTORNEY-IN-FACT	_____
<input type="checkbox"/> TRUSTEE(S)	_____
<input type="checkbox"/> GUARDIAN/CONSERVATOR	_____
<input type="checkbox"/> OTHER: _____	_____
SIGNER IS REPRESENTING:	_____
NAME OF PERSON(S) OR ENTITY(IES)	_____

CALIFORNIA ALL-PURPOSE ACKNOWLEDGMENT

A notary public or other offices completing this certificate verifies only the identity of the Individual who signed the document to which this certificate is attached, and not the truthfulness, accuracy, or validity of that document.

State of CALIFORNIA

County of ORANGE

On August 30, 2021 before me YAZMIN BARRERA VALDES, NOTARY PUBLIC

Personally appeared KINAN KOTRASH

who proved to me on the basis of satisfactory evidence to be the person(s) whose name(s) is/are subscribed to the within instrument and acknowledged to me that he/she/they executed the same in his/her/their authorized capacity (ies), and that by his/her/their signature(s) on the instrument the person(s), or the entity upon behalf of which the person(s) acted, executed the instrument.

I certify under PENALTY OF PERJURY under the laws of the State of California that the foregoing paragraph is true and correct.

WITNESS my hand and official seal.

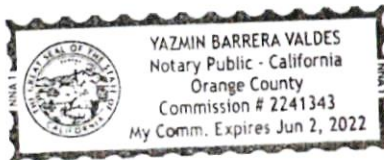

Signature of Notary

OPTIONAL

Though the data below is not required by law, it may prove valuable to persons relying on the document and could prevent fraudulent reattachment of this form.

CAPACITY CLAIMED BY SIGNER

- INDIVIDUAL
- CORPORATE OFFICER
- LIMITED
- PARTNER(S)
- ATTORNEY-IN-FACT
- TRUSTEE(S)
- GUARDIAN/CONSERVATOR
- OTHER: _____

DESCRIPTION OF ATTACHED DOCUMENT

Payment Bond
Bond No.: EZIQC-HCC-FM05430009579.00

SIGNER IS REPRESENTING:
NAME OF PERSON(S) OR ENTITY (IES)

Horizons Construction Co. Int'l, Inc.

Bond No.: WCN 5951504
*** In Triplicate ***

**THE FINAL PREMIUM IS
PREDICATED ON THE
FINAL CONTRACT PRICE**

Bond No. EZIQC-HHC-FM05430009579.00

PERFORMANCE BOND

(Public Work – Public Contract Code Section 20129 (b))

KNOW ALL PERSONS BY THESE PRESENTS:

THAT WHEREAS, the County of Riverside ("County") by action of the Board of Supervisors has awarded Construction Contract Number EZIQC-HHC-FM05430009579.00 ("Contract") to **HORIZONS CONSTRUCTION COMPANY INTERNATIONAL, INC.** as Principal ("Principal") to perform the work ("Work") for the **Kitchen Dishwasher and Flooring Replacement** project; which Contract is by this reference hereby incorporated herein and made a part hereof;

AND, WHEREAS, said Principal is required by the Contract and/or by California Public Contract Code, Section 20129 (b) to furnish a performance bond for the faithful performance of the Contract;

Old Republic

NOW THEREFORE, we, the Principal and Surety Company ("Surety"), an admitted surety insurer pursuant to Code of Civil Procedure, Section 995.120, are held and firmly bound unto County in the penal sum of One Hundred Fifty-Five Thousand, One Hundred Seventy-Six and 00/100 Dollars (\$155,176.00), this amount being not less than one hundred percent (100%) of the total sum payable by County under the Contract at the time the Contract is awarded by County to the Principal, lawful money of the United States of America, for the payment of which sum well and truly to be made, we, Principal and Surety, bind ourselves, our heirs, executors, administrators, successors and assigns, jointly and severally, firmly by these presents.

THE CONDITION OF THIS OBLIGATION IS SUCH that if Principal, its heirs, executors, administrators, successors or assigns approved by County, shall in all things stand to and abide by and well and truly keep and perform all the undertakings, terms, covenants, conditions and agreements in the Contract, including, without limitation, all obligations during the original term and any extensions thereof as may be granted by County, with or without notice to Surety thereof (including, without limitation, the obligation for Principal to pay liquidated damages), all obligations during the period of any warranties and guarantees required under the Contract and all other obligations otherwise arising under the terms of the Contract (such as, but not limited to, obligations of indemnification), all within the time and in the manner therein designated in all respects according to their true intent and meaning, then this obligation shall become null and void; otherwise, it shall be and remain in full force and effect.

Whenever Principal shall be, and is declared by County to be, in default under the Contract, the Surety shall promptly either remedy the default, or, if the Contract is terminated by County or the Principal's performance of the Work is discontinued, Surety shall promptly complete the Contract through its agents or independent contractors, subject to acceptance of such agents or independent contractors by County as hereinafter set forth, in accordance with its terms and conditions and to pay and perform all obligations of

Principal under the Contract (including, without limitation, all obligations with respect to payment of liquidated damages) less the "Balance of the Contract Price" (as hereinafter defined); subject to the penal amount of this bond as set forth above. The term "Balance of the Contract Price," as used in this paragraph, shall mean the total amount payable to Principal by County under the Contract and any modifications thereto, less the amount previously paid by County to the Principal and less amounts that County is authorized to withhold under the terms of the Contract.

If County determines that completion of the Contract by Surety or its agents or independent contractors must be performed by a lowest responsible bidder selected pursuant to a competitive bidding process, then Surety shall comply with such processes in accordance with the requirements of County and applicable laws. Unless otherwise approved by County, in the exercise of its sole and absolute discretion, Surety shall not utilize Principal in completing performance of the Work.

No right of action shall accrue on this bond to or for the use of any person or entity other than County or its successors or assigns.

In the event any legal proceeding or arbitration is brought upon this bond by County and judgment or award is entered in favor of County as the prevailing party, Surety shall pay all costs and attorney's fees incurred by the County.

Correspondence or claims relating to this bond shall be sent to Surety at the address set forth below.

Surety, for value received, agrees that no change, extension of time, alteration or addition to the terms of the Contract, or to the work to be performed thereunder, shall in any way impair or affect Surety's obligation under this bond, and Surety does hereby waive notice of any such changes, extensions of time, alterations or additions.

Surety's obligations hereunder are independent of the obligations of any other surety for the performance of the Contract, and suit may be brought against Surety and such other sureties, joint and severally, or against any one or more of them or against less than all of them, without impairing County's rights against the others.

Horizons Construction Company International, Inc.
(Firm Name – Principal)

432 Meats Avenue
Orange, CA 92865

(Business Address)

By 
(Original Signature)

Affix Seal if Corporation

v. President + Secretary
(Title)

Old Republic Surety Company
(Corporation Name – Surety)

Affix Corporate Seal

14728 Pipeline Avenue, Suite E
Chino Hills, CA 91709

(Business Address)

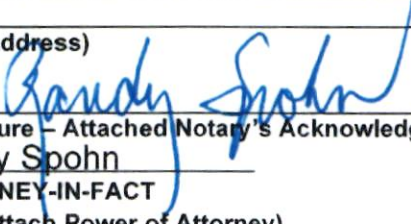
By 
(Signature – Attached Notary's Acknowledgment)
Randy Spohn
ATTORNEY-IN-FACT
(Title-Attach Power of Attorney)

Note: Notary acknowledgment of signatures of Contractor and Surety, and Surety's Power of Attorney, must be included or attached



OLD REPUBLIC SURETY COMPANY

POWER OF ATTORNEY

KNOW ALL MEN BY THESE PRESENTS: That OLD REPUBLIC SURETY COMPANY, a Wisconsin stock insurance corporation, does make, constitute and appoint:

Randy Spohn, Matthew R. Dobyms, Ashley M. Spohn of Santa Ana, CA

its true and lawful Attorney(s)-in-Fact, with full power and authority for and on behalf of the company as surety, to execute and deliver and affix the seal of the company thereto (if a seal is required), bonds, undertakings, recognizances or other written obligations in the nature thereof, (other than bail bonds, bank depository bonds, mortgage deficiency bonds, mortgage guaranty bonds, guarantees of installment paper and note guaranty bonds, self-insurance workers compensation bonds guaranteeing payment of benefits, or black lung bonds), as follows:

ALL WRITTEN INSTRUMENTS

and to bind OLD REPUBLIC SURETY COMPANY thereby, and all of the acts of said Attorneys-in-Fact, pursuant to these presents, are ratified and confirmed. This appointment is made under and by authority of the board of directors at a special meeting held on February 18, 1982.

This Power of Attorney is signed and sealed by facsimile under and by the authority of the following resolutions adopted by the board of directors of the OLD REPUBLIC SURETY COMPANY on February 18, 1982.

RESOLVED that, the president, any vice president or assistant vice president, in conjunction with the secretary or any assistant secretary, may appoint attorneys-in-fact or agents with authority as defined or limited in the instrument evidencing the appointment in each case, for and on behalf of the company to execute and deliver and affix the seal of the company to bonds, undertakings, recognizances, and suretyship obligations of all kinds; and said officers may remove any such attorney-in-fact or agent and revoke any Power of Attorney previously granted to such person.

RESOLVED FURTHER, that any bond, undertaking, recognizance, or suretyship obligation shall be valid and binding upon the Company

- (i) when signed by the president, any vice president or assistant vice president, and attested and sealed (if a seal be required) by any secretary or assistant secretary; or
- (ii) when signed by the president, any vice president or assistant vice president, secretary or assistant secretary, and countersigned and sealed (if a seal be required) by a duly authorized attorney-in-fact or agent; or
- (iii) when duly executed and sealed (if a seal be required) by one or more attorneys-in-fact or agents pursuant to and within the limits of the authority evidenced by the Power of Attorney issued by the company to such person or persons.

RESOLVED FURTHER that the signature of any authorized officer and the seal of the company may be affixed by facsimile to any Power of Attorney or certification thereof authorizing the execution and delivery of any bond, undertaking, recognizance, or other suretyship obligations of the company; and such signature and seal when so used shall have the same force and effect as though manually affixed.

IN WITNESS WHEREOF, OLD REPUBLIC SURETY COMPANY has caused these presents to be signed by its proper officer, and its corporate seal to be affixed this 18th day of May, 2021.

Karen J. Haffner
Assistant Secretary



OLD REPUBLIC SURETY COMPANY

Alan Pavlic
President

STATE OF WISCONSIN, COUNTY OF WAUKESHA - SS

On this 18th day of May, 2021, personally came before me, Alan Pavlic and Karen J. Haffner, to me known to be the individuals and officers of the OLD REPUBLIC SURETY COMPANY who executed the above instrument, and they each acknowledged the execution of the same, and being by me duly sworn, did severally depose and say: that they are the said officers of the corporation aforesaid, and that the seal affixed to the above instrument is the seal of the corporation, and that said corporate seal and their signatures as such officers were duly affixed and subscribed to the said instrument by the authority of the board of directors of said corporation.



Kathryn R. Pearson
Notary Public

My Commission Expires: September 28, 2022

(Expiration of notary's commission does not invalidate this instrument)

CERTIFICATE

I, the undersigned, assistant secretary of the OLD REPUBLIC SURETY COMPANY, a Wisconsin corporation, CERTIFY that the foregoing and attached Power of Attorney remains in full force and has not been revoked; and furthermore, that the Resolutions of the board of directors set forth in the Power of Attorney, are now in force.



74 7097

Signed and sealed at the City of Brookfield, WI this 25th day of August, 2021.

Karen J. Haffner
Assistant Secretary

ORSC 22262 (3-06)

CALIFORNIA ALL-PURPOSE ACKNOWLEDGMENT

A notary public or other officer completing this certificate verifies only the identity of the individual who signed the document to which this certificate is attached, and not the truthfulness, accuracy, or validity of that document.

State of CALIFORNIA

County of ORANGE

On 8/25/2011 before me, ERIKA G. MORGAN, NOTARY PUBLIC,

personally appeared RANDY SPOHN

- who proved to me on the basis of satisfactory evidence to be the person(s) whose name(s) is/are subscribed to the within instrument and acknowledged to me that he/she/they executed the same in his/her/their authorized capacity (ies), and that by his/her/their signature(s) on the instrument the person(s), or the entity upon behalf of which the person(s) acted, executed the instrument.

I certify under PENALTY OF PERJURY under the laws of the State of California that the foregoing paragraph is true and correct.

WITNESS my hand and official seal.



Erika G. Morgan
Signature of Notary

OPTIONAL

Though the data below is not required by law, it may prove valuable to persons relying on the document and could prevent fraudulent reattachment of this form.

CAPACITY CLAIMED BY SIGNER	DESCRIPTION OF ATTACHED DOCUMENT
<input type="checkbox"/> INDIVIDUAL	_____
<input type="checkbox"/> CORPORATE OFFICER	_____
<input type="checkbox"/> PARTNER(S)	_____
<input checked="" type="checkbox"/> ATTORNEY-IN-FACT	_____
<input type="checkbox"/> TRUSTEE(S)	_____
<input type="checkbox"/> GUARDIAN/CONSERVATOR	_____
<input type="checkbox"/> OTHER: _____	_____
SIGNER IS REPRESENTING:	_____
NAME OF PERSON(S) OR ENTITY(IES)	_____

CALIFORNIA ALL-PURPOSE ACKNOWLEDGMENT

A notary public or other offices completing this certificate verifies only the identity of the Individual who signed the document to which this certificate is attached, and not the truthfulness, accuracy, or validity of that document.

State of CALIFORNIA

County of ORANGE

On August 30, 2021 before me YAZMIN BARRERA VALDES, NOTARY PUBLIC

Personally appeared KINAN KOTRASH

who proved to me on the basis of satisfactory evidence to be the person(s) whose name(s) is/are subscribed to the within instrument and acknowledged to me that he/she/they executed the same in his/her/their authorized capacity (ies), and that by his/her/their signature(s) on the instrument the person(s), or the entity upon behalf of which the person(s) acted, executed the instrument.

I certify under PENALTY OF PERJURY under the laws of the State of California that the foregoing paragraph is true and correct.

WITNESS my hand and official seal.

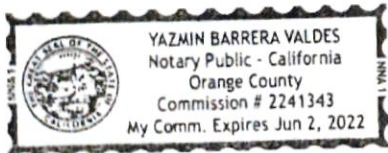

Yazmin

Signature of Notary

OPTIONAL

Though the data below is not required by law, it may prove valuable to persons relying on the document and could prevent fraudulent reattachment of this form.

CAPACITY CLAIMED BY SIGNER

DESCRIPTION OF ATTACHED DOCUMENT

- INDIVIDUAL
- CORPORATE OFFICER
- LIMITED
- PARTNER(S)
- ATTORNEY-IN-FACT
- TRUSTEE(S)
- GUARDIAN/CONSERVATOR
- OTHER: _____

Performance Bond
Bond No.: EZIQC-HCC-FM05430009579.00

**SIGNER IS REPRESENTING:
NAME OF PERSON(S) OR ENTITY (IES)**

Horizons Construction Co. Int'l, Inc.

CONTRACTOR'S CERTIFICATE REGARDING WORKERS'
COMPENSATION

Labor Code Section 3700 states:

"Every employer except the state shall secure the payment of compensation in one or more of the following ways:

(a) By being insured against liability to pay compensation by one or more insurers duly authorized to write compensation insurance in this state.

(b) By securing from the Director of Industrial Relations a certificate of consent to self-insure either as an individual employer, or as one employer in a group of employers, which may be given upon furnishing proof satisfactory to the Director of Industrial Relations of ability to self-insure and to pay any compensation that may become due to his or her employee.

(c) For any county, city, city and county, municipal corporation, public district, public agency, or any political subdivision of the state, including each member of a pooling arrangement under a joint exercise of powers agreement (but not the state itself), by securing from the Director of Industrial Relations a certificate of consent to self-insure against workers' compensation claims, which certificate may be given upon furnishing proof satisfactory to the director of ability to administer workers' compensation claims properly, and to pay workers' compensation claims that may become due to its employees. On or before March 31, 1979, a political subdivision of the state which, on December 31, 1978, was uninsured for its liability to pay compensation, shall file a properly completed and executed application for a certificate of consent to self-insure against workers' compensation claims. The certificate shall be issued and be subject to the provisions of Section 3702.

For purposes of this section, 'state' shall include the superior courts of California."

I am aware of the provisions of Section 3700 of the California Labor Code which require every employer to be insured against liability for workers' compensation or to undertake self-insurance in accordance with the provisions of that code, and I will comply with such provisions before commencing the performance of the work of this contract.

HORIZONS CONSTRUCTION COMPANY
INTERNATIONAL, INC.

(Name of Contractor)

Kinan Kotrash

By: _____

Kinan Kotrash, V. President & Secretary

(Name of Signer)

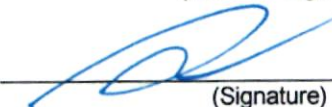

(Signature)

(In accordance with Article 5 (commencing at Section 1860), Chapter 1, Part 7, Division 2 of the Labor Code, the above certificate must be signed and filed with the awarding body prior to performing any work under this contract.)

Policy Number: GLP3415075

THIS ENDORSEMENT CHANGES THE POLICY. PLEASE READ IT CAREFULLY.

**ADDITIONAL INSURED - OWNERS, LESSEES OR
CONTRACTORS - COMPLETED OPERATIONS**

This endorsement modifies insurance provided under the following:

COMMERCIAL GENERAL LIABILITY COVERAGE PART

Schedule

**Name of Additional Insured Person(s) or
Organization(s):**

Location and Description of Completed Operations:

Any person or organization that "you" and such person or organization have agreed in writing in a contract that such person or organization be added as an additional insured on "your" policy, but only for "your work" performed during this policy period.

"Your work" performed during this policy period.

Additional Premium: Included

Information required to complete this Schedule, if not shown above, will be shown in the Declarations.

SECTION II - WHO IS AN INSURED is amended to include as an Additional Insured the person(s) or organization(s) shown in the Schedule, but only with respect to liability for "bodily injury" or "property damage" caused, in whole or in part, by "your work" at the location designated and described in the schedule of this endorsement performed for that Additional Insured and included in the "products-completed operations hazard."

THIS ENDORSEMENT CHANGES THE POLICY. PLEASE READ IT CAREFULLY.

ADDITIONAL INSURED - OWNERS, LESSEES OR CONTRACTORS - AUTOMATIC STATUS WHEN REQUIRED IN CONSTRUCTION AGREEMENT WITH YOU

This endorsement modifies insurance provided under the following:

COMMERCIAL GENERAL LIABILITY COVERAGE PART

A. SECTION II - WHO IS AN INSURED is amended to include as an Additional Insured any person or organization for whom you are performing operations when you and such person or organization have agreed in writing in a contract or agreement that such person or organization be added as an Additional Insured on your policy. Such person or organization is an Additional Insured only with respect to liability for "bodily injury," "property damage" or "personal and advertising injury" caused, in whole or in part, by:

- 1. your acts or omissions; or
- 2. the acts or omissions of those acting on your behalf;

in the performance of your ongoing operations for the Additional Insured.

A person's or organization's status as an Additional Insured under this endorsement ends when your operations for that Additional Insured are completed.

B. With respect to the insurance afforded to these Additional Insureds, the following additional exclusions apply:

This insurance does not apply to:

- 1. "Bodily injury," "property damage" or "personal and advertising injury" arising out of the rendering of, or the failure to render, any professional architectural, engineering or surveying services, including:
 - a. the preparing, approving, or failing to prepare or approve, maps, shop drawings, opinions, reports, surveys, field orders, change orders or drawings and specifications; or
 - b. supervisory, inspection, architectural or engineering activities.
- 2. "Bodily injury," or "property damage" occurring after:
 - a. all work, including materials, parts or equipment furnished in connection with such work, on the project (other than service, maintenance or repairs) to be performed by or on behalf of the Additional Insured(s) at the location of the covered operations has been completed; or
 - b. that portion of "your work" out of which the injury or damage arises has been put to its intended use by any person or organization other than another contractor or subcontractor engaged in performing operations for a principal as a part of the same project.



HORICON-01

DIANNA

CERTIFICATE OF LIABILITY INSURANCE

DATE (MM/DD/YYYY)
9/1/2021

THIS CERTIFICATE IS ISSUED AS A MATTER OF INFORMATION ONLY AND CONFERS NO RIGHTS UPON THE CERTIFICATE HOLDER. THIS CERTIFICATE DOES NOT AFFIRMATIVELY OR NEGATIVELY AMEND, EXTEND OR ALTER THE COVERAGE AFFORDED BY THE POLICIES BELOW. THIS CERTIFICATE OF INSURANCE DOES NOT CONSTITUTE A CONTRACT BETWEEN THE ISSUING INSURER(S), AUTHORIZED REPRESENTATIVE OR PRODUCER, AND THE CERTIFICATE HOLDER.

IMPORTANT: If the certificate holder is an ADDITIONAL INSURED, the policy(ies) must have ADDITIONAL INSURED provisions or be endorsed. If SUBROGATION IS WAIVED, subject to the terms and conditions of the policy, certain policies may require an endorsement. A statement on this certificate does not confer rights to the certificate holder in lieu of such endorsement(s).

PRODUCER Goodman Insurance Services, Inc. 27042 Towne Centre Drive, Suite 120 Foothill Ranch, CA 92610	CONTACT NAME: PHONE (A/C, No, Ext): (949) 769-3100	FAX (A/C, No): (949) 769-3930
	E-MAIL ADDRESS:	
INSURER(S) AFFORDING COVERAGE		NAIC #
INSURER A: Wesco Insurance Company		25011
INSURED Horizons Construction Company International, Inc. 432 West Meats Avenue Orange, CA 92865	INSURER B:	
	INSURER C:	
	INSURER D:	
	INSURER E:	
	INSURER F:	
	INSURER G:	

COVERAGES **CERTIFICATE NUMBER:** **REVISION NUMBER:**

THIS IS TO CERTIFY THAT THE POLICIES OF INSURANCE LISTED BELOW HAVE BEEN ISSUED TO THE INSURED NAMED ABOVE FOR THE POLICY PERIOD INDICATED. NOTWITHSTANDING ANY REQUIREMENT, TERM OR CONDITION OF ANY CONTRACT OR OTHER DOCUMENT WITH RESPECT TO WHICH THIS CERTIFICATE MAY BE ISSUED OR MAY PERTAIN, THE INSURANCE AFFORDED BY THE POLICIES DESCRIBED HEREIN IS SUBJECT TO ALL THE TERMS, EXCLUSIONS AND CONDITIONS OF SUCH POLICIES. LIMITS SHOWN MAY HAVE BEEN REDUCED BY PAID CLAIMS.

INSR LTR	TYPE OF INSURANCE	ADDL INSD	SUBR WVD	POLICY NUMBER	POLICY EFF (MM/DD/YYYY)	POLICY EXP (MM/DD/YYYY)	LIMITS
	COMMERCIAL GENERAL LIABILITY <input type="checkbox"/> CLAIMS-MADE <input type="checkbox"/> OCCUR GEN'L AGGREGATE LIMIT APPLIES PER: <input type="checkbox"/> POLICY <input type="checkbox"/> PRO-JECT <input type="checkbox"/> LOC OTHER:						EACH OCCURRENCE \$ DAMAGE TO RENTED PREMISES (Ea occurrence) \$ MED EXP (Any one person) \$ PERSONAL & ADV INJURY \$ GENERAL AGGREGATE \$ PRODUCTS - COMP/OP AGG \$ \$
A	AUTOMOBILE LIABILITY <input checked="" type="checkbox"/> ANY AUTO OWNED AUTOS ONLY <input type="checkbox"/> HIRED AUTOS ONLY <input type="checkbox"/> SCHEDULED AUTOS <input type="checkbox"/> NON-OWNED AUTOS ONLY	X	X	WPP1922176-00	6/19/2021	6/19/2022	COMBINED SINGLE LIMIT (Ea accident) \$ 1,000,000 BODILY INJURY (Per person) \$ BODILY INJURY (Per accident) \$ PROPERTY DAMAGE (Per accident) \$ \$
	UMBRELLA LIAB <input type="checkbox"/> OCCUR EXCESS LIAB <input type="checkbox"/> CLAIMS-MADE DED RETENTION \$						EACH OCCURRENCE \$ AGGREGATE \$ \$
	WORKERS COMPENSATION AND EMPLOYERS' LIABILITY ANY PROPRIETOR/PARTNER/EXECUTIVE OFFICER/MEMBER EXCLUDED? (Mandatory in NH) <input type="checkbox"/> Y/N If yes, describe under DESCRIPTION OF OPERATIONS below		N/A				PER STATUTE OTH-ER E.L. EACH ACCIDENT \$ E.L. DISEASE - EA EMPLOYEE \$ E.L. DISEASE - POLICY LIMIT \$

DESCRIPTION OF OPERATIONS / LOCATIONS / VEHICLES (ACORD 101, Additional Remarks Schedule, may be attached if more space is required)
Certificate Holder(s) are named as additional insured with respect to the Commercial Auto Liability per the attached and a waiver of subrogation applies, this insurance is Primary & Non-Contributory applies per the attached when required by written contract for the following project:

Project: RUHSMC - Kitchen Dishwasher and Flooring Replacement Project - EZIQC-HCC-FM05430009579

CERTIFICATE HOLDER County of Riverside 3133 Mission Inn Ave Riverside, CA 92507	CANCELLATION SHOULD ANY OF THE ABOVE DESCRIBED POLICIES BE CANCELLED BEFORE THE EXPIRATION DATE THEREOF, NOTICE WILL BE DELIVERED IN ACCORDANCE WITH THE POLICY PROVISIONS. AUTHORIZED REPRESENTATIVE 
---	--

This Endorsement Changes The Policy. Please Read It Carefully

BUSINESS AUTO COVERAGE EXPANSION ENDORSEMENT

This endorsement modifies insurance provided by the following:

BUSINESS AUTO COVERAGE FORM

With respect to coverage provided by this endorsement, the provisions of the COVERAGE FORM apply unless modified by the endorsement.

A. Newly Acquired or Formed

Organizations, Employee Hired Car Liability and Blanket Additional Insured Status for Certain Entities.

Item 1. Who is an Insured of Paragraph A. Coverage under SECTION II – COVERED AUTOS LIABILITY COVERAGE is amended to add:

- d. Any organization you newly acquire or form, other than a partnership, joint venture or limited liability company, and over which you maintain ownership of a majority interest (greater than 50%), will qualify as a Named Insured; however,
 - (1) coverage under this provision is afforded only until the 180th day after you acquire or form the organization or the end of the policy period, whichever is earlier;
 - (2) coverage does not apply to "bodily injury", "property damage" or "covered pollution cost or expense" that results from an "accident" which occurred before you acquired or formed the organization; and
 - (3) coverage does not apply if there is other similar insurance available to that organization, or if similar insurance would have been available but for its termination or the exhaustion of its limits of insurance.

This insurance does not apply if coverage for the newly acquired or formed organization is excluded either by the provisions of this coverage form or by endorsement.

- e. An "employee" of yours is an "insured" while operating an "auto" hired or rented under a contract or agreement in that "employee's" name, with your permission, while performing duties related to the conduct of your business.
- f. Any person or organization you are required by written contract or agreement to name as an additional "insured", but only with respect to liability created in whole or in part by such agreement.

B. Increase Of Loss Earnings Payment

Subpart (4) of a. Supplementary Payments of Item 2. Coverage Extensions of Paragraph A. Coverage under SECTION II – COVERED AUTOS LIABILITY COVERAGE is amended to read:

- (4) We will pay reasonable expenses incurred by the "insured" at our request, including actual loss of earnings up to \$1,000 per day because of time off from work.

C. Fellow Employee Injured By Covered Auto You Own Or Hire

Item 5. Fellow Employee of Paragraph B. Exclusions under SECTION II – COVERED AUTOS LIABILITY COVERAGE is amended to add:

This exclusion does not apply if the "bodily injury" results from the use of a covered "auto" you own or hire. Such coverage as is afforded by this provision is excess over any other collectible insurance.

D. Limited Automatic Towing Coverage

Item 2. Towing, of Paragraph A. Coverage, under SECTION III – PHYSICAL DAMAGE COVERAGE is amended to read:

2. Towing

We will pay for towing and labor costs each time that a covered "auto" is disabled. All labor must be performed at the place of disablement of the covered "auto".

- a. The limit for towing and labor for each disablement is \$500;
- b. No deductible applies to this coverage.

E. Item 3. Glass Breakage – Hitting A Bird Or Animal – Falling Objects or Missiles of Paragraph A. Coverage under SECTION III – PHYSICAL DAMAGE COVERAGE, is amended to add:

Glass Repair Coverage

We will waive the Comprehensive deductible for Glass, if one is indicated on your covered "auto", for glass repairs. We will repair at no cost to you, any glass that can be repaired without replacement, provided the "loss" arises from a covered Comprehensive "loss" to your "auto".

F. Increase Of Transportation Expense Coverage

Subpart a. Transportation Expenses of Item 4. Coverage Extensions of Paragraph A. Coverage under SECTION III – PHYSICAL DAMAGE COVERAGE is amended to read:

a. Transportation Expenses

We will pay up to \$50 per day to a maximum of \$1,000 for temporary transportation expense incurred by you because of the total theft of a covered "auto" of the private passenger type. We will pay only for those covered "autos" for which you carry either Comprehensive or Specified Causes of Loss Coverage or Theft Coverage. We will pay for temporary transportation expenses incurred during the period beginning 48 hours after the theft and ending, regardless of the policy's expiration, when the covered "auto" is returned to use or we pay for its "loss".

G. "Personal Effects" Coverage

Item 4. Coverage Extensions of Paragraph A. Coverage, under SECTION III - PHYSICAL DAMAGE COVERAGE, is amended to add:

"Personal Effects" Coverage

We will pay actual cash value for "loss" to "personal effects" of the "insured" while in a covered "auto" subject to a maximum limit of \$2,500 per "loss", for that covered "auto" caused by the same "accident". No deductible will apply to this coverage.

H. "Downtime Loss" Coverage

Item 4. Coverage Extensions, of Paragraph A. Coverage, under SECTION III. PHYSICAL DAMAGE COVERAGE, is amended to add:

"Downtime Loss" Coverage

We will pay any resulting "downtime loss" expenses you sustain as a result of a covered physical damage "loss" to a covered "auto" up to a maximum of \$100 per day, for a maximum of 30 days for the same physical damage "loss", subject to the following conditions:

- a. We will provide "downtime loss" beginning on the 5th day after we have given you our agreement to pay for repairs to a covered "auto" and you have given the repair facility your authorization to make repairs;
- b. Coverage for "downtime loss" expenses will end when any of the following occur:
 - (1) You have a spare or reserve "auto" available to you to continue your operations.
 - (2) You purchase a replacement "auto".
 - (3) Repairs to your covered "auto" have been completed by the repair facility and they determine the covered "auto" is road-worthy.
 - (4) You reach the 30 day maximum coverage.

I. **Item 4. Coverage Extensions**, of Paragraph A. **Coverage**, under **SECTION III. PHYSICAL DAMAGE COVERAGE**, is amended to add:

We will pay any resulting rental reimbursement expenses incurred by you for a rental of an "auto" because of "loss" to a covered "auto" up to a maximum of \$100 per day, for a maximum of 30 days for the same physical damage "loss", subject to the following conditions:

- a. We will provide rental reimbursement incurred during the policy period beginning 24 hours after the "loss" and ending, regardless of the policy expiration, with the number of days reasonably required to repair or replace the covered "auto". If the "loss" is caused by theft, this number of days is the number of days it takes to locate the covered "auto" and return it to you or the number of days it takes for the claim to be settled, whichever comes first.
- b. Our payment is limited to necessary and actual expenses incurred.
- c. This coverage does not apply while there are spare or reserve "autos" available to you for your operations.
- d. If a "loss" results from the total theft of a covered "auto" of the private passenger type, we will pay under this coverage only that amount of your rental reimbursement expenses which is not already provided for under the Physical Damage Coverage Extension.

J. **"Personal Effects" Exclusion**

Paragraph B. **Exclusions** under **SECTION III – PHYSICAL DAMAGE COVERAGE**, is amended to add:

"Personal Effects" Exclusion

We will not pay for "loss" to "personal effects" of any of the following:

- a. Accounts, bills, currency, deeds, evidence of debt, money, notes, securities or commercial paper or other documents of value.
- b. Bullion, gold, silver, platinum, or other precious alloys or metals; furs or fur garments; jewelry; watches; precious or semi-precious stones.
- c. Paintings, statuary and other works of art.

- d. Contraband or property in the course of illegal transportation or trade.
- e. "Loss" caused by theft, unless there is evidence of forced entry into the covered "auto" and a police report is filed.

K. **Accidental Airbag Discharge Coverage**

Item 3.a. of Paragraph B. **Exclusions** under **SECTION III – PHYSICAL DAMAGE COVERAGE** is amended to read:

- a. Wear and tear, freezing, mechanical or electrical breakdown. The exclusion relating to mechanical break-down does not apply to the accidental discharge of an air bag.

L. **Loan or Lease Gap Coverage**

Paragraph C. **Limit Of Insurance** under **SECTION III – PHYSICAL DAMAGE COVERAGE** is amended to add:

If a covered "auto" is owned or leased and if we provide Physical Damage Coverage on it, we will pay, in the event of a covered total "loss", any unpaid amount due on the lease or loan for a covered "auto", less:

- a. The amount paid under the Physical Damage Coverage Section of the policy; and
- b. Any:
 - (1) Overdue lease or loan payments including penalties, interest or other charges resulting from overdue payments at the time of the "loss";
 - (2) Financial penalties imposed under a lease for excessive use, abnormal wear and tear or high mileage;
 - (3) Costs for extended warranties, Credit Life Insurance, Health, Accident or Disability Insurance purchased with the loan or lease;
 - (4) Security deposits not refunded by the lessor; and
 - (5) Carry-over balances from previous loans or leases

M. Aggregate Deductible

Paragraph D. **Deductible** under **SECTION III – PHYSICAL DAMAGE COVERAGE** is amended to add:

Regardless of the number of covered "autos" involved in the same "loss", only one deductible will apply to that "loss". If the deductible amounts vary by "autos", then only the highest applicable deductible will apply to that "loss".

N. Diminishing Deductible

Paragraph D. **Deductible** under **SECTION III – PHYSICAL DAMAGE COVERAGE** is amended to add:

Any deductible will be reduced by the percentage indicated below on the first "loss" reported during the corresponding policy period:

Loss Free Policy Periods With the Expansion Endorsement	Deductible Reduction on the first "loss"
1	0%
2	25%
3	50%
4	75%
5	100%

If we pay a Physical Damage "loss" during the policy period under any **BUSINESS AUTO COVERAGE FORM** you have with us, your deductible stated in the Declarations page of each such **COVERAGE FORM** will not be reduced on any subsequent claims during the remainder of your policy period and your deductible reduction will revert back to 0% for each such **COVERAGE FORM** if coverage is renewed.

O. Knowledge of Loss and Notice To Us

Subsection a. of Item 2. **Duties In the Event of Accident, Claim, Suit or Loss of Paragraph A. Loss Conditions** under **SECTION IV – BUSINESS AUTO CONDITIONS** is amended to add:

However, prompt notice of the "accident", claim, "suit" or "loss" to us or our authorized representative only applies after the "accident", claim, "suit" or "loss" is known to:

- (1) You, if you are an individual;
- (2) A partner, if you are a partnership;

- (3) An "executive officer" or director, if you are a corporation;
- (4) A manager or member, if you are a limited liability company;
- (5) Your insurance manager; or
- (6) Your legal representative.

P. Waiver Of Subrogation For Auto Liability Losses Assumed Under Insured Contract

Item 5. **Transfer Of Rights Of Recovery Against Others To Us** of Paragraph A. **Loss Conditions** under **SECTION IV – BUSINESS AUTO CONDITIONS** is amended to read:

5. Transfer of Rights of Recovery Against Others To Us

If any person or organization to or for whom we make payments under this Coverage Form has rights to recover damages from another, those rights are transferred to us. That person or organization must do everything necessary to secure our rights and must do nothing after an "accident" or "loss" to impair them. However, if the insured has waived those rights to recover through a written contract, we will waive any right to recovery we may have under this Coverage Form.

Q. Insurance is Primary and Noncontributory

Subpart a. of Item 5. **Other Insurance** of Paragraph B. **General Conditions** under **SECTION IV – BUSINESS AUTO CONDITIONS** is amended to read:

- a. This insurance is primary and noncontributory, as respects any other insurance, if required in a written contract with you.

R. Other Insurance – Hired Auto Physical Damage

Subpart b. of Item 5. **Other Insurance** of Paragraph B. **General Conditions** under **SECTION IV – BUSINESS AUTO CONDITIONS** is amended to read:

- b. For **Hired Auto Physical Damage Coverage**, the following are deemed to be covered "autos" you own:
 - (1) Any covered "auto" you lease, hire, rent or borrow; and

- (2) Any covered "auto" hired or rented by your "employee" under a contract in that individual "employee's" name, with your permission, while performing duties related to the conduct of your business.

However, any "auto" that is leased, hired, rented or borrowed with a driver is not a covered "auto".

S. Unintentional Failure To Disclose Hazards

Paragraph **B. General Conditions** under **SECTION IV – BUSINESS AUTO CONDITIONS** is amended to add:

9. Your failure to disclose all hazards existing as of the inception date of this policy shall not prejudice the coverage afforded by this policy, provided that such failure to disclose all hazards is not intentional. However, you must report such previously undisclosed hazards to us as soon as practicable after its discovery.

T. Additional Definition

SECTION V – DEFINITIONS is amended to add:

"Personal effects" means personal property owned by the "insured".

"Downtime loss" means actual loss of "business income" for the period of time that a covered "auto":

1. Is out of service for repair or replacement as a result of a covered physical damage "loss" and
2. Is in the custody of a repair facility if not a total "loss".

"Business Income" means:

1. Net Income (Net Profit or Loss before income taxes) that would have been earned or incurred; and
2. Continuing normal operating expenses incurred, including payroll.

In this endorsement, Headings and Titles are inserted solely for the convenience and ease of reference. They do not affect the coverage provided by this endorsement, nor do they constitute any part of the terms and conditions of this endorsement. All other policy wording not specifically changed, modified, or replaced by this endorsement wording remains in effect.



HORICON-02

IFATHIPOUR

CERTIFICATE OF LIABILITY INSURANCE

DATE (MM/DD/YYYY)

9/1/2021

THIS CERTIFICATE IS ISSUED AS A MATTER OF INFORMATION ONLY AND CONFERS NO RIGHTS UPON THE CERTIFICATE HOLDER. THIS CERTIFICATE DOES NOT AFFIRMATIVELY OR NEGATIVELY AMEND, EXTEND OR ALTER THE COVERAGE AFFORDED BY THE POLICIES BELOW. THIS CERTIFICATE OF INSURANCE DOES NOT CONSTITUTE A CONTRACT BETWEEN THE ISSUING INSURER(S), AUTHORIZED REPRESENTATIVE OR PRODUCER, AND THE CERTIFICATE HOLDER.

IMPORTANT: If the certificate holder is an ADDITIONAL INSURED, the policy(ies) must have ADDITIONAL INSURED provisions or be endorsed. If SUBROGATION IS WAIVED, subject to the terms and conditions of the policy, certain policies may require an endorsement. A statement on this certificate does not confer rights to the certificate holder in lieu of such endorsement(s).

PRODUCER Paramount Exclusive Insurance Services, Inc. 15760 Ventura Blvd. Suite 500 Encino, CA 91436	CONTACT NAME: _____														
	PHONE (A/C, No, Ext): (818) 986-7283														
	FAX (A/C, No): (818) 986-4949														
	E-MAIL ADDRESS: _____														
	<table border="1"> <tr> <th>INSURER(S) AFFORDING COVERAGE</th> <th>NAIC #</th> </tr> <tr> <td>INSURER A : Service American Indemnity Company</td> <td>39152</td> </tr> <tr> <td>INSURER B :</td> <td></td> </tr> <tr> <td>INSURER C :</td> <td></td> </tr> <tr> <td>INSURER D :</td> <td></td> </tr> <tr> <td>INSURER E :</td> <td></td> </tr> <tr> <td>INSURER F :</td> <td></td> </tr> </table>	INSURER(S) AFFORDING COVERAGE	NAIC #	INSURER A : Service American Indemnity Company	39152	INSURER B :		INSURER C :		INSURER D :		INSURER E :		INSURER F :	
INSURER(S) AFFORDING COVERAGE	NAIC #														
INSURER A : Service American Indemnity Company	39152														
INSURER B :															
INSURER C :															
INSURER D :															
INSURER E :															
INSURER F :															
INSURED Horizons Construction Company International, Inc. 432 West Meats Ave Orange, CA 92865															

COVERAGES **CERTIFICATE NUMBER:** **REVISION NUMBER:**

THIS IS TO CERTIFY THAT THE POLICIES OF INSURANCE LISTED BELOW HAVE BEEN ISSUED TO THE INSURED NAMED ABOVE FOR THE POLICY PERIOD INDICATED. NOTWITHSTANDING ANY REQUIREMENT, TERM OR CONDITION OF ANY CONTRACT OR OTHER DOCUMENT WITH RESPECT TO WHICH THIS CERTIFICATE MAY BE ISSUED OR MAY PERTAIN, THE INSURANCE AFFORDED BY THE POLICIES DESCRIBED HEREIN IS SUBJECT TO ALL THE TERMS, EXCLUSIONS AND CONDITIONS OF SUCH POLICIES. LIMITS SHOWN MAY HAVE BEEN REDUCED BY PAID CLAIMS.

INSR LTR	TYPE OF INSURANCE	ADDL INSD	SUBR WVD	POLICY NUMBER	POLICY EFF (MM/DD/YYYY)	POLICY EXP (MM/DD/YYYY)	LIMITS
	COMMERCIAL GENERAL LIABILITY <input type="checkbox"/> CLAIMS-MADE <input type="checkbox"/> OCCUR GEN'L AGGREGATE LIMIT APPLIES PER: <input type="checkbox"/> POLICY <input type="checkbox"/> PRO-JECT <input type="checkbox"/> LOC OTHER: _____						EACH OCCURRENCE \$ DAMAGE TO RENTED PREMISES (Ea occurrence) \$ MED EXP (Any one person) \$ PERSONAL & ADV INJURY \$ GENERAL AGGREGATE \$ PRODUCTS - COMP/OP AGG \$ _____ \$
	AUTOMOBILE LIABILITY <input type="checkbox"/> ANY AUTO OWNED AUTOS ONLY <input type="checkbox"/> SCHEDULED AUTOS <input type="checkbox"/> HIRED AUTOS ONLY <input type="checkbox"/> NON-OWNED AUTOS ONLY						COMBINED SINGLE LIMIT (Ea accident) \$ BODILY INJURY (Per person) \$ BODILY INJURY (Per accident) \$ PROPERTY DAMAGE (Per accident) \$ _____ \$
	UMBRELLA LIAB <input type="checkbox"/> OCCUR EXCESS LIAB <input type="checkbox"/> CLAIMS-MADE DED RETENTION \$						EACH OCCURRENCE \$ AGGREGATE \$ _____ \$
A	WORKERS COMPENSATION AND EMPLOYERS' LIABILITY ANY PROPRIETOR/PARTNER/EXECUTIVE OFFICER/MEMBER EXCLUDED? (Mandatory in NH) If yes, describe under DESCRIPTION OF OPERATIONS below	<input checked="" type="checkbox"/> Y <input type="checkbox"/> N <input type="checkbox"/> I/N <input checked="" type="checkbox"/> Y N/A		SATIS0458500	7/15/2021	7/15/2022	<input checked="" type="checkbox"/> PER STATUTE <input type="checkbox"/> OTH-ER E.L. EACH ACCIDENT \$ 1,000,000 E.L. DISEASE - EA EMPLOYEE \$ 1,000,000 E.L. DISEASE - POLICY LIMIT \$ 1,000,000

DESCRIPTION OF OPERATIONS / LOCATIONS / VEHICLES (ACORD 101, Additional Remarks Schedule, may be attached if more space is required)
Project: RUHSMC - Kitchen Dishwasher and Flooring Replacement Project EZIQC-HCC-FM05430009579

CERTIFICATE HOLDER Cunty of Riverside 3133 Mission Inn Ave. Riverside, CA 92507	CANCELLATION SHOULD ANY OF THE ABOVE DESCRIBED POLICIES BE CANCELLED BEFORE THE EXPIRATION DATE THEREOF, NOTICE WILL BE DELIVERED IN ACCORDANCE WITH THE POLICY PROVISIONS. AUTHORIZED REPRESENTATIVE 
---	--

DECLARATION OF SUFFICIENCY OF FUNDS

(California Labor Code Section 2810)

I, the undersigned, an authorized representative of Horizons Construction Company International, Inc. ("Contractor") with authority to make the statements contained in this Declaration on behalf of the Contractor, hereby declare the following:

1. The Contractor's employer identification number for state tax purposes is 14-1865687.

2. The Contractor's workers' compensation insurance policy number is SATIS0458500 and the name, address, and telephone number of the insurance carrier providing said insurance is: Service American Indemnity Company
6907 N. Capital of Texas Hwy Austin TX, 78731.

3. The following information is provided concerning any and all vehicles that are owned by the Contractor and that will be used for transportation in connection with any service provided for the performance of the Work that is the subject of the Contract [Insert information requested. Attach additional sheets, if needed.]:

<i>Vehicle</i>	<i>Vehicle ID #</i>	<i>Vehicle Liability Insurance Policy Number (of policy covering vehicle)</i>	<i>Name, Address and Telephone Number of Vehicle Liability Insurance Carrier (issuing policy covering vehicle)</i>
2008 Ford Pickup	14650Z2	WPP1922176-00	Wesco Insurance Co. 420 Maple Ave. Yukon, OK73099 405-354-5201

4. The following is the address of any real property that will be used to house workers in connection with the performance of the Work that is the subject of the Contract [If no such housing will be provided, enter "none"]: None

5. The actual or estimated number of workers that will be employed to perform the Work that is the subject of the Contract, the total amount of wages to be paid to said workers, and the dates on which said wages will be paid are as follows [Attach additional sheets, if needed.]:

<i>Total Number of Workers</i>	<i>Total Amount of Wages</i>	<i>Date(s) for Payment of Wages</i>
3	\$14,000	Weekly

6. Check only one of the following boxes, as applicable:

The statement of number of workers declared in Paragraph 5, above, is a statement of the actual number of workers that will be employed.

The actual number of workers requested in Paragraph 5, above, is unknown and therefore the statement of number of workers declared therein is based on the Contractor's best estimate available at the time of submitting its Proposal, rather than the actual number of workers that will be employed and if and when the actual number of workers and the other information requested above is available, it will be reported to the County of Riverside by Bidder in writing.

7. The actual or estimated total number of persons who will be utilized as independent contractors to perform the Work of the Project that is the subject of the Contract (together with their known, current local, state, and federal contractor license identification numbers that each is required to have under local, state or federal laws or regulations) are as follows [Attach additional sheets, if needed.]:

<i>List of Independent Contractors</i>	<i>Current, local, state and federal contractor license identification number</i>
None	

8. Check only one of the following boxes, as applicable:

The statement of number of independent contractors declared in Paragraph 7, above, is a statement of the actual number of independent contractors that will be utilized.

The actual number of independent contractors requested in Paragraph 7, above, is unknown and therefore the statement of number of independent contractors declared therein is based on the Contractor's best estimate available at the time of submitting its Proposal, rather than the actual number of independent contractors that will be utilized, and if and when the actual number of independent

contractors and the other information requested above is available, it will be reported to the County of Riverside by Bidder in writing.

I, the undersigned, declare under penalty of perjury that the foregoing statements are within my personal knowledge and are true and correct. Executed on this 30th day of August, in the year 2024 at orange, California.



(signature)

Kinan Kotrash, V. President & Secretary
Type Name of Signer:

Horizons Construction Co. Int'l, Inc.
Type Name of Bidder: