

**SUBMITTAL TO THE BOARD OF SUPERVISORS
COUNTY OF RIVERSIDE, STATE OF CALIFORNIA**



**ITEM: 3.35
(ID # 24357)**

MEETING DATE:
Tuesday, April 09, 2024

FROM : TLMA-TRANSPORTATION:

SUBJECT: TRANSPORTATION AND LAND MANAGEMENT AGENCY/TRANSPORTATION:
Approve Addenda to the Plans and Specifications, Accept the Low Bid and Award the Contract for the Construction of the Lakepointe Drive Reconstruction Project, in the Community of Lake Hills; District 2. [\$1,761,383 Total Cost - State Exchange 48.6%, American Rescue Plan Act 51.1%, and Western Municipal Water District 0.3%]

RECOMMENDED MOTION: That the Board of Supervisors:

1. Approve two addenda to the plans and specifications issued prior to the January 17, 2024, bid opening;
2. Waive any and all immaterial irregularities and accept the low bid of All American Asphalt of Corona, California in the amount of \$1,761,383;
3. Award the contract to All American Asphalt and authorize the Chair of the Board to execute the contract documents; and
4. Approve the project proposed budget as shown on Attachment "A".

ACTION:Policy

Patricia Romo, Director of Transportation 3/5/2024

MINUTES OF THE BOARD OF SUPERVISORS

On motion of Supervisor Gutierrez, seconded by Supervisor Perez and duly carried by unanimous vote, IT WAS ORDERED that the above matter is approved as recommended.

Ayes: Jeffries, Spiegel, Washington, Perez and Gutierrez
Nays: None
Absent: None
Date: April 9, 2024
xc: Trans.

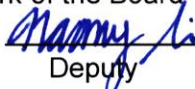
Kimberly A. Rector
Clerk of the Board
By: 
Deputy

**SUBMITTAL TO THE BOARD OF SUPERVISORS COUNTY OF RIVERSIDE,
STATE OF CALIFORNIA**

FINANCIAL DATA	Current Fiscal Year:	Next Fiscal Year:	Total Cost:	Ongoing Cost
COST	\$ 1,361,383	\$ 400,000	\$ 1,761,383	\$ 0
NET COUNTY COST	\$ 0	\$ 0	\$ 0	\$ 0
SOURCE OF FUNDS: State Exchange (48.6%), American Rescue Plan Act (51.1%); and Western Municipal Water District (0.3%). There are no General Funds used in this project.			Budget Adjustment: No	
			For Fiscal Year: 23/24, 24/25	

C.E.O. RECOMMENDATION: Approve

BACKGROUND:

Summary

By Minute Order dated November 28, 2023 (Agenda Item 3.47), the County of Riverside Board of Supervisors authorized the Clerk of the Board to advertise for the construction of the Lakepointe Drive Reconstruction Project. The limits on Lakepointe Drive are from Indiana Avenue to the southern connection of Sun Summit Drive.

Lakepointe Drive is a two-lane facility that travels in the North-South directions with a road width between 40 feet and 60 feet wide with curb and gutter on both sides and is currently classified as a local road. The area in the immediate vicinity includes a residential area with single family dwellings and hilly open spaces.

Roadway reconstruction is needed due to the deteriorated pavement condition. The reconstruction project consists of removing existing asphalt concrete pavement and underlying material and placing back new Hot Mix Asphalt (HMA). Where base and/or subgrade failure has occurred, the existing asphalt concrete pavement and underlying material will be removed and placed back with new HMA over aggregate base, with a geogrid placed between the aggregate base and natural soil to provide subgrade enhancement thus preventing premature failure of the pavement structure.

Additional improvements include construction of a subsurface drainage system and reconstruction of Americans with Disabilities Act (ADA) compliant concrete access ramps, sidewalk, driveways, curb and gutter, and cross gutters. Additional roadway features include placement of thermoplastic crosswalk and pavement marking, roadside signs, and other associated work.

On March 11, 2021, President Biden signed the \$1.9 trillion American Rescue Plan Act (ARPA) of 2021 into law. To accelerate recovery from the economic and health impacts of the COVID-19 pandemic, the County of Riverside was provided approximately \$480 million. The Executive Office in conjunction with the Board of Supervisors developed a plan to disburse these funds based on the principles of providing recovery funding to those sectors of our economy and

**SUBMITTAL TO THE BOARD OF SUPERVISORS COUNTY OF RIVERSIDE,
STATE OF CALIFORNIA**

society that are struggling most to recover from the pandemic; have a constituent and community based focus; provide a vehicle for transformational investment in our County's recovery from COVID-19; provide for countywide equity; and focus on one time investments, rather than funding ongoing operational costs. As a result of these principles, the Lakepointe Drive Resurfacing project was selected as a recipient of these funds by Minute Order 3.2 of the 2/27/24 Board of Supervisors Meeting Agenda.

During the advertisement period, two addenda were issued to all registered plan holders as a supplement to the plans and specifications. Bidders were required to acknowledge and take into account the issued addenda on their contractor's Bid in order to be considered for award.

The addenda were issued to supplement, clarify and modify the approved contract documents. The addenda are attached and designated as Addendum No. 1 and Addendum No. 2.

The Contract includes the following schedules of work:

Base Bid Schedule: Lakepointe Drive Reconstruction
Alternative Bid Schedule 1: Western Municipal Water District (WMWD) Facility Adjustments

WMWD has accepted the bid prices proposed by All American Asphalt for Alternative Bid Schedule 1 which includes adjustments of sixteen (16) sewer manhole covers, and the cost for the work will be reimbursed by WMWD through reimbursement Agreement. The Director of Transportation has the authority to sign reimbursement Agreements up to \$100,000 per Minute Order dated November 19, 2019 (Agenda Item 3.25).

The contractor, All American Asphalt, is qualified to perform the work as outlined in the bid, has executed the contract, and has provided bonds and insurance documents which meet the requirements of the contract documents.

Project No. D2-0049

Impact on Residents and Businesses

The purpose of this project is to replace existing deteriorated pavement with new hot mix asphalt for an approximate 0.82-mile segment of Lakepointe Drive in the Community of Lake Hills to provide the public with a smooth paved roadway for vehicular traffic.

The work is scheduled to begin in late spring 2024 and will take approximately three months to complete.

SUPPLEMENTAL:

Additional Fiscal Information

Construction is expected to be completed in Fiscal Year 2024/2025 and will be funded with State Exchange, American Rescue Plan Act (ARPA), and WMWD funds.

**SUBMITTAL TO THE BOARD OF SUPERVISORS COUNTY OF RIVERSIDE,
STATE OF CALIFORNIA**

The proposed budget as shown on Attachment "A" includes Contract award amount and other associated costs.

There are no General Funds used in this project.

Contract History and Price Reasonableness

A total of seven bids were received on Wednesday January 17, 2024 ranging from \$1,761,383 to \$2,653,806. The basis for the selection of a contractor is the lowest responsive and responsible bid. The lowest responsive and responsible bid was submitted by All American Asphalt in the amount of \$1,761,383, which is \$281,418 (13.8%) below the engineer's cost estimate.

The Transportation Department recommends the award of the contract to All American Asphalt in the amount of \$1,761,383.

ATTACHMENTS:

Vicinity Map
Attachment "A"
Summary of Bids
Addendum No. 1
Addendum No. 2
Contract/Bonds/Insurance
Contractor's Bid Proposal



Jason Farin, Principal Management Analyst 4/3/2024



Aaron Gettis, Chief of Deputy County Counsel 3/26/2024

COUNTY OF RIVERSIDE
TRANSPORTATION DEPARTMENT

LAKEPOINTE DR

RECONSTRUCTION PROJECT

INDIANA AVE TO S SUN SUMMIT DR

COMMUNITY OF LAKE HILLS
PROJECT WO No. D2-0049

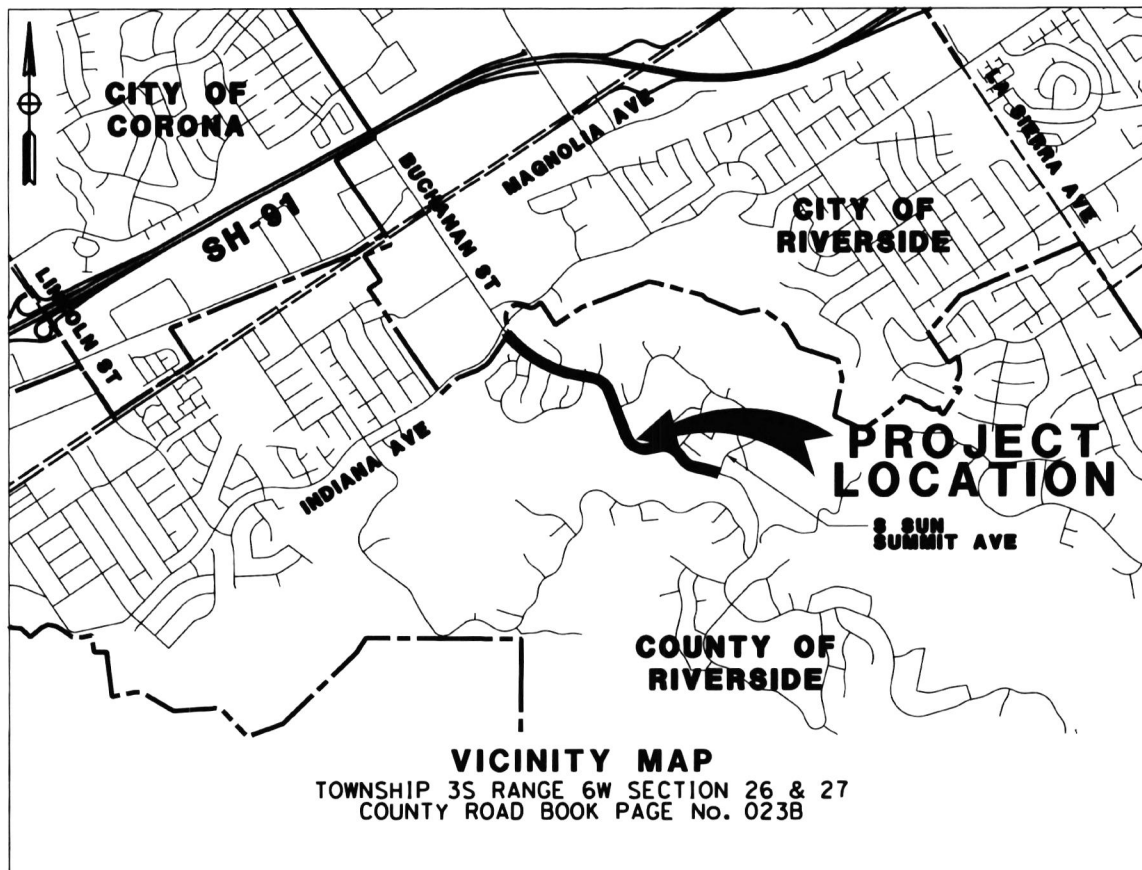
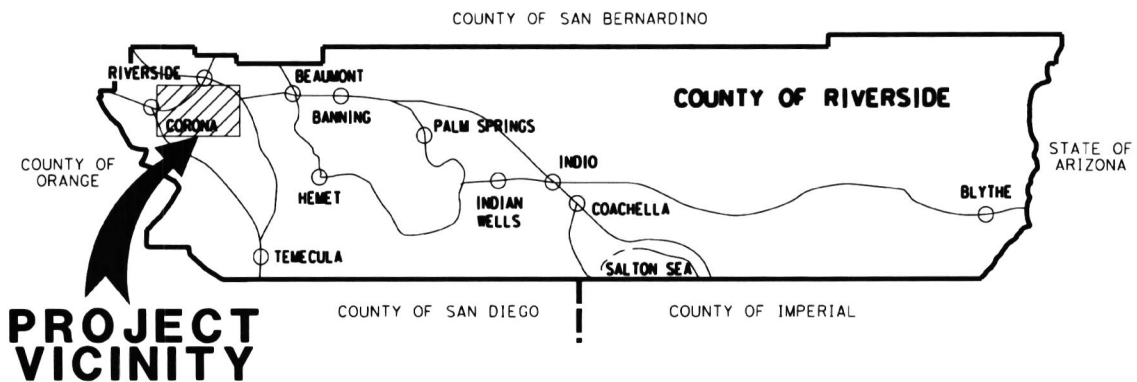

Attachment "A"

County of Riverside - Transportation Department

Expenses as of 2/7/2024

Project: **Lakepointe Drive Reconstruction**

Project No.: **D2-0049**

Project Costs and Budget

Activity	Incurred Costs	Projected Costs	Total Costs	Existing Budget	Proposed Budget
Preliminary Survey	70,801		71,000	75,000	71,000
Environmental	1,442		2,000	12,000	2,000
Design	277,600	10,000	288,000	258,000	288,000
Right-of-way					
Utilities					
Construction		1,761,383	1,938,000	1,800,000	1,938,000
Construction Contingency 10%		176,138			
Construction Engineering & Inspection	728	280,000	281,000	270,000	281,000
Construction Survey		90,000	90,000	90,000	90,000
Totals:	350,571	2,317,521	2,670,000	2,505,000	2,670,000

Project Funding

Code	Name	Existing Budget	Proposed Budget
101	State Exchange Funds	1,640,000	1,640,000
223	Gas Tax / SB-1	865,000	123,000
387	American Rescue Plan Act (ARPA)		900,000
844	Western Municipal Water District		7,000
Totals		2,505,000	2,670,000

Comments

**Riverside County Transportation Department
Summary of Bids**

**PROJECT: Lakepointe Drive Reconstruction
Indiana Avenue to Southern Sun Summit Drive
Community of Lake Hills
Project No. D2-0049**

Advertised: November 28, 2023 (Agenda Item: 3.47)
Addenda: 1 (12/13/23), 2 (1/4/24)
Bids Open: 2 pm Date: Wednesday, January 17, 2024

Company Name	BASE BID SCHEDULE Lakepointe Drive Reconstruction	ALTERNATIVE BID SCHEDULE 1 Western Municipal Water District (WMWD) Facility Adjustments	Project Total
COUNTY'S ESTIMATE	2,018,801.00	24,000.00	\$2,042,801.00
1 All American Asphalt	1,755,830.60	5,552.00	\$1,761,382.60
2 LCR Earthwork & Eng, Corp.	1,852,472.50	24,000.00	\$1,876,472.50
3 Onyx Paving Company, Inc.	2,064,000.00	24,000.00	\$2,088,000.00
4 Hardy & Harper. Inc.	2,150,000.00	20,000.00	\$2,170,000.00
5 ATP General Engineering Contractors	2,208,508.75	14,000.00	\$2,222,508.75
6 Hillcrest Contracting, Inc.	2,199,852.30	23,360.00	\$2,223,212.30
7 IE General Engineering Inc.	2,597,805.50	56,000.00	\$2,653,805.50
<i>Average Bid Prices</i>	\$2,118,352.81	\$23,844.57	\$2,142,197.38

**Riverside County Transportation Department
Summary of Bids**

**PROJECT: Lakepointe Drive Reconstruction
Indiana Avenue to Southern Sun Summit Drive
Community of Lake Hills
Project No. D2-0049**

Advertised: November 28, 2023 (Agenda Item: 3.47)

Addenda: 1 (12/13/23), 2 (1/4/24)

Bids Open: 2 pm Date: Wednesday, January 17, 2024

BASE BID SCHEDULE - Lakepointe Drive Reconstruction					COUNTY'S ESTIMATE		All American Asphalt Corona, CA 92879 ¹	
ITEM NO.	ITEM CODE	CONTRACT ITEM	UNITS	QUANTITY	UNIT PRICE	ENG ESTIMATE	BID UNIT PRICE	BID ESTIMATE
1	066100	DUST ABATEMENT	LS	1	10,000.00	10,000.00	5,000.00	5,000.00
2	100100	DEVELOP WATER SUPPLY	LS	1	10,000.00	10,000.00	3,000.00	3,000.00
3	120100	TRAFFIC CONTROL SYSTEM	LS	1	100,000.00	100,000.00	220,000.00	220,000.00
4	130200	PREPARE WATER POLLUTION CONTROL PROGRAM	LS	1	10,000.00	10,000.00	8,880.85	8,880.85
5	170103	CLEARING AND GRUBBING	LS	1	15,000.00	15,000.00	15,000.00	15,000.00
6	190101(F)	ROADWAY EXCAVATION	CY	3,891	70.00	272,370.00	70.00	272,370.00
7	260203	CLASS 2 AGGREGATE BASE	CY	390	75.00	29,250.00	54.00	21,060.00
8	198215	SUBGRADE ENHANCEMENT GEOGRID	SQYD	2,330	5.50	12,815.00	4.00	9,320.00
9	729011	ROCK SLOPE PROTECTION FABRIC (CLASS 8)	SQYD	468	8.00	3,744.00	2.00	936.00
10	680287	3" SLOTTED PLASTIC PIPE UNDERDRAIN [SCH 80]	LF	545	30.00	16,350.00	76.00	41,420.00
11	681107	3" PLASTIC PIPE (EDGE DRAIN OUTLET) [SCH 80]	LF	40	80.00	3,200.00	300.00	12,000.00
12	710212	ADJUST MANHOLE TO GRADE [STORM DRAIN]	EA	12	1,500.00	18,000.00	1,400.00	16,800.00
13	720110	SMALL-ROCK SLOPE PROTECTION [PERMEABLE MATERIAL - CRUSHED ROCK]	CY	23	250.00	5,750.00	140.00	3,220.00
14	390132	HOT MIX ASPHALT (TYPE A)	TON	7,647	140.00	1,070,580.00	102.00	779,994.00
15	731521	MINOR CONCRETE (SIDEWALK)	SQFT	874	25.00	21,850.00	14.00	12,236.00
15.A	017315	MINOR CONCRETE (CURB RAMP) (CRS 403 - CASE A)	EA	16	10,000.00	160,000.00	8,800.00	140,800.00
15.B	017317	MINOR CONCRETE (CROSS-GUTTER AND SPANDREL)	SQFT	2,980	45.00	134,100.00	26.00	77,480.00
16	017304	MINOR CONCRETE (CURB AND GUTTER) (CRS 200)	LF	30	150.00	4,500.00	80.00	2,400.00

**Riverside County Transportation Department
Summary of Bids**

**PROJECT: Lakepointe Drive Reconstruction
Indiana Avenue to Southern Sun Summit Drive
Community of Lake Hills
Project No. D2-0049**

Advertised: November 28, 2023 (Agenda Item: 3.47)

Addenda: 1 (12/13/23), 2 (1/4/24)

Bids Open: 2 pm Date: Wednesday, January 17, 2024

BASE BID SCHEDULE - Lakepointe Drive Reconstruction (continued)					COUNTY'S ESTIMATE		All American Asphalt ¹ Corona, CA 92879	
ITEM NO.	ITEM CODE	CONTRACT ITEM	UNITS	QUANTITY	UNIT PRICE	ENG ESTIMATE	BID UNIT PRICE	BID ESTIMATE
17	017310	MINOR CONCRETE (DRIVEWAY APPROACH) (CRS 207)	SQFT	400	40.00	16,000.00	20.00	8,000.00
18	000001	ITEM DELETED PER ADDENDUM No. 2	----	----	----	----	----	----
19	820410	SALVAGE ROADSIDE SIGN	EA	16	100.00	1,600.00	100.00	1,600.00
20	820840	ROADSIDE SIGN - ONE POST	EA	20	350.00	7,000.00	375.00	7,500.00
21	810230(F)	PAVEMENT MARKER (RETROREFLECTIVE)	EA	370	15.00	5,550.00	8.50	3,145.00
22	840519	THERMOPLASTIC CROSSWALK AND PAVEMENT MARKING	SQFT	905	5.00	4,525.00	5.75	5,203.75
23	840656(F)	PAINT TRAFFIC STRIPE (2-COAT)	LF	4,620	0.35	1,617.00	0.75	3,465.00
24	010602	MISCELLANEOUS WORK (AS DIRECTED)	FA	1	85,000.00	85,000.00	85,000.00	85,000.00
		BASE BID SCH - SUB-TOTAL ITEMS 1 - 24				2,018,801.00		1,755,830.60

ALTERNATIVE BID SCHEDULE 1 - Western Municipal Water District (WMWD) Facility Adjustments

ITEM NO.	ITEM CODE	CONTRACT ITEM	UNITS	QUANTITY	UNIT PRICE	ENG ESTIMATE	BID UNIT PRICE	BID ESTIMATE
25	710228	ADJUST SEWER MANHOLE	EA	16	1,500.00	24,000.00	347.00	5,552.00
		ALT BID SCH 1 - SUB-TOTAL ITEM 25				24,000.00		5,552.00

PROJECT TOTAL ITEMS 1 - 25						2,042,801.00		1,761,382.60
---------------------------------------	--	--	--	--	--	---------------------	--	---------------------

**Riverside County Transportation Department
Summary of Bids**

**PROJECT: Lakepointe Drive Reconstruction
Indiana Avenue to Southern Sun Summit Drive
Community of Lake Hills
Project No. D2-0049**

Advertised: November 28, 2023 (Agenda Item: 3.47)

Addenda: 1 (12/13/23), 2 (1/4/24)

Bids Open: 2 pm Date: Wednesday, January 17, 2024

BASE BID SCHEDULE - Lakepointe Drive Reconstruction					2 LCR Earthwork & Eng, Corp. Jurupa Valley, CA 92509		3 Onyx Paving Company, Inc. Anaheim, CA 92806	
ITEM NO.	ITEM CODE	CONTRACT ITEM	UNITS	QUANTITY	BID UNIT PRICE	BID ESTIMATE	BID UNIT PRICE	BID ESTIMATE
1	066100	DUST ABATEMENT	LS	1	25,000.00	25,000.00	24,000.00	24,000.00
2	100100	DEVELOP WATER SUPPLY	LS	1	10,000.00	10,000.00	38,252.24	38,252.24
3	120100	TRAFFIC CONTROL SYSTEM	LS	1	85,000.00	85,000.00	169,000.00	169,000.00
4	130200	PREPARE WATER POLLUTION CONTROL PROGRAM	LS	1	15,000.00	15,000.00	24,000.00	24,000.00
5	170103	CLEARING AND GRUBBING	LS	1	25,000.00	25,000.00	96,000.00	96,000.00
6	190101(F)	ROADWAY EXCAVATION	CY	3,891	65.00	252,915.00	63.00	245,133.00
7	260203	CLASS 2 AGGREGATE BASE	CY	390	110.00	42,900.00	123.00	47,970.00
8	198215	SUBGRADE ENHANCEMENT GEOGRID	SQYD	2,330	25.00	58,250.00	7.77	18,104.10
9	729011	ROCK SLOPE PROTECTION FABRIC (CLASS 8)	SQYD	468	45.00	21,060.00	7.77	3,636.36
10	680287	3" SLOTTED PLASTIC PIPE UNDERDRAIN [SCH 80]	LF	545	75.00	40,875.00	88.00	47,960.00
11	681107	3" PLASTIC PIPE (EDGE DRAIN OUTLET) [SCH 80]	LF	40	100.00	4,000.00	88.00	3,520.00
12	710212	ADJUST MANHOLE TO GRADE [STORM DRAIN]	EA	12	1,500.00	18,000.00	1,500.00	18,000.00
13	720110	SMALL-ROCK SLOPE PROTECTION [PERMEABLE MATERIAL - CRUSHED ROCK]	CY	23	250.00	5,750.00	444.00	10,212.00
14	390132	HOT MIX ASPHALT (TYPE A)	TON	7,647	115.00	879,405.00	123.00	940,581.00
15	731521	MINOR CONCRETE (SIDEWALK)	SQFT	874	20.00	17,480.00	13.00	11,362.00
15.A	017315	MINOR CONCRETE (CURB RAMP) (CRS 403 - CASE A)	EA	16	8,000.00	128,000.00	9,600.00	153,600.00
15.B	017317	MINOR CONCRETE (CROSS-GUTTER AND SPANDREL)	SQFT	2,980	30.00	89,400.00	30.00	89,400.00
16	017304	MINOR CONCRETE (CURB AND GUTTER) (CRS 200)	LF	30	125.00	3,750.00	123.00	3,690.00

**Riverside County Transportation Department
Summary of Bids**

**PROJECT: Lakepointe Drive Reconstruction
Indiana Avenue to Southern Sun Summit Drive
Community of Lake Hills
Project No. D2-0049**

Advertised: November 28, 2023 (Agenda Item: 3.47)

Addenda: 1 (12/13/23), 2 (1/4/24)

Bids Open: 2 pm Date: Wednesday, January 17, 2024

BASE BID SCHEDULE - Lakepointe Drive Reconstruction (continued)					2 LCR Earthwork & Eng. Corp. Jurupa Valley, CA 92509		3 Onyx Paving Company, Inc. Anaheim, CA 92806	
ITEM NO.	ITEM CODE	CONTRACT ITEM	UNITS	QUANTITY	BID UNIT PRICE	BID ESTIMATE	BID UNIT PRICE	BID ESTIMATE
17	017310	MINOR CONCRETE (DRIVEWAY APPROACH) (CRS 207)	SQFT	400	45.00	18,000.00	22.00	8,800.00
18	000001	ITEM DELETED PER ADDENDUM No. 2	----	----	----	----	----	----
19	820410	SALVAGE ROADSIDE SIGN	EA	16	125.00	2,000.00	111.00	1,776.00
20	820840	ROADSIDE SIGN - ONE POST	EA	20	500.00	10,000.00	444.00	8,880.00
21	810230(F)	PAVEMENT MARKER (RETROREFLECTIVE)	EA	370	6.00	2,220.00	9.99	3,696.30
22	840519	THERMOPLASTIC CROSSWALK AND PAVEMENT MARKING	SQFT	905	8.50	7,692.50	6.96	6,298.80
23	840656(F)	PAINT TRAFFIC STRIPE (2-COAT)	LF	4,620	1.25	5,775.00	1.11	5,128.20
24	010602	MISCELLANEOUS WORK (AS DIRECTED)	FA	1	85,000.00	85,000.00	85,000.00	85,000.00
BASE BID SCH - SUB-TOTAL ITEMS 1 - 24						1,852,472.50		2,064,000.00

ALTERNATIVE BID SCHEDULE 1 - Western Municipal Water District (WMWD) Facility Adjustments

ITEM NO.	ITEM CODE	CONTRACT ITEM	UNITS	QUANTITY	BID UNIT PRICE	BID ESTIMATE	BID UNIT PRICE	BID ESTIMATE
25	710228	ADJUST SEWER MANHOLE	EA	16	1,500.00	24,000.00	1,500.00	24,000.00
ALT BID SCH 1 - SUB-TOTAL ITEM 25						24,000.00		24,000.00

PROJECT TOTAL ITEMS 1 - 25					1,876,472.50	2,088,000.00
---------------------------------------	--	--	--	--	---------------------	---------------------

**Riverside County Transportation Department
Summary of Bids**

**PROJECT: Lakepointe Drive Reconstruction
Indiana Avenue to Southern Sun Summit Drive
Community of Lake Hills
Project No. D2-0049**

Advertised: November 28, 2023 (Agenda Item: 3.47)

Addenda: 1 (12/13/23), 2 (1/4/24)

Bids Open: 2 pm Date: Wednesday, January 17, 2024

BASE BID SCHEDULE - Lakepointe Drive Reconstruction					4 Hardy & Harper, Inc. Lake Forest, CA 92630		5 ATP General Engineering Contractors San Diego, CA 92123	
ITEM NO.	ITEM CODE	CONTRACT ITEM	UNITS	QUANTITY	BID UNIT PRICE	BID ESTIMATE	BID UNIT PRICE	BID ESTIMATE
1	066100	DUST ABATEMENT	LS	1	30,000.00	30,000.00	10,000.00	10,000.00
2	100100	DEVELOP WATER SUPPLY	LS	1	30,000.00	30,000.00	10,000.00	10,000.00
3	120100	TRAFFIC CONTROL SYSTEM	LS	1	189,345.00	189,345.00	208,000.00	208,000.00
4	130200	PREPARE WATER POLLUTION CONTROL PROGRAM	LS	1	20,000.00	20,000.00	950.00	950.00
5	170103	CLEARING AND GRUBBING	LS	1	200,000.00	200,000.00	15,000.00	15,000.00
6	190101(F)	ROADWAY EXCAVATION	CY	3,891	70.00	272,370.00	115.00	447,465.00
7	260203	CLASS 2 AGGREGATE BASE	CY	390	200.00	78,000.00	92.00	35,880.00
8	198215	SUBGRADE ENHANCEMENT GEOGRID	SQYD	2,330	2.00	4,660.00	6.00	13,980.00
9	729011	ROCK SLOPE PROTECTION FABRIC (CLASS 8)	SQYD	468	5.00	2,340.00	1.75	819.00
10	680287	3" SLOTTED PLASTIC PIPE UNDERDRAIN [SCH 80]	LF	545	175.00	95,375.00	35.00	19,075.00
11	681107	3" PLASTIC PIPE (EDGE DRAIN OUTLET) [SCH 80]	LF	40	250.00	10,000.00	122.50	4,900.00
12	710212	ADJUST MANHOLE TO GRADE [STORM DRAIN]	EA	12	1,250.00	15,000.00	875.00	10,500.00
13	720110	SMALL-ROCK SLOPE PROTECTION [PERMEABLE MATERIAL - CRUSHED ROCK]	CY	23	150.00	3,450.00	250.00	5,750.00
14	390132	HOT MIX ASPHALT (TYPE A)	TON	7,647	110.00	841,170.00	136.00	1,039,992.00
15	731521	MINOR CONCRETE (SIDEWALK)	SQFT	874	15.00	13,110.00	11.00	9,614.00
15.A	017315	MINOR CONCRETE (CURB RAMP) (CRS 403 - CASE A)	EA	16	8,500.00	136,000.00	10,750.00	172,000.00
15.B	017317	MINOR CONCRETE (CROSS-GUTTER AND SPANDREL)	SQFT	2,980	30.00	89,400.00	29.00	86,420.00
16	017304	MINOR CONCRETE (CURB AND GUTTER) (CRS 200)	LF	30	100.00	3,000.00	115.00	3,450.00

**Riverside County Transportation Department
Summary of Bids**

**PROJECT: Lakepointe Drive Reconstruction
Indiana Avenue to Southern Sun Summit Drive
Community of Lake Hills
Project No. D2-0049**

Advertised: November 28, 2023 (Agenda Item: 3.47)

Addenda: 1 (12/13/23), 2 (1/4/24)

Bids Open: 2 pm Date: Wednesday, January 17, 2024

BASE BID SCHEDULE - Lakepointe Drive Reconstruction (continued)					4 Hardy & Harper, Inc. Lake Forest, CA 92630		5 ATP General Engineering Contractors San Diego, CA 92123	
ITEM NO.	ITEM CODE	CONTRACT ITEM	UNITS	QUANTITY	BID UNIT PRICE	BID ESTIMATE	BID UNIT PRICE	BID ESTIMATE
17	017310	MINOR CONCRETE (DRIVEWAY APPROACH) (CRS 207)	SQFT	400	22.00	8,800.00	22.00	8,800.00
18	000001	ITEM DELETED PER ADDENDUM No. 2	-----	-----	-----	-----	-----	-----
19	820410	SALVAGE ROADSIDE SIGN	EA	16	100.00	1,600.00	100.00	1,600.00
20	820840	ROADSIDE SIGN - ONE POST	EA	20	400.00	8,000.00	375.00	7,500.00
21	810230(F)	PAVEMENT MARKER (RETROREFLECTIVE)	EA	370	9.00	3,330.00	8.50	3,145.00
22	840519	THERMOPLASTIC CROSSWALK AND PAVEMENT MARKING	SQFT	905	6.00	5,430.00	5.75	5,203.75
23	840656(F)	PAINT TRAFFIC STRIPE (2-COAT)	LF	4,620	1.00	4,620.00	0.75	3,465.00
24	010602	MISCELLANEOUS WORK (AS DIRECTED)	FA	1	85,000.00	85,000.00	85,000.00	85,000.00
BASE BID SCH - SUB-TOTAL ITEMS 1 - 24						2,150,000.00		2,208,508.75

ALTERNATIVE BID SCHEDULE 1 - Western Municipal Water District (WMWD) Facility Adjustments

ITEM NO.	ITEM CODE	CONTRACT ITEM	UNITS	QUANTITY	BID UNIT PRICE	BID ESTIMATE	BID UNIT PRICE	BID ESTIMATE
25	710228	ADJUST SEWER MANHOLE	EA	16	1,250.00	20,000.00	875.00	14,000.00
ALT BID SCH 1 - SUB-TOTAL ITEM 25						20,000.00		14,000.00

PROJECT TOTAL ITEMS 1 - 25					2,170,000.00	2,222,508.75
---------------------------------------	--	--	--	--	---------------------	---------------------

**Riverside County Transportation Department
Summary of Bids**

**PROJECT: Lakepointe Drive Reconstruction
Indiana Avenue to Southern Sun Summit Drive
Community of Lake Hills
Project No. D2-0049**

Advertised: November 28, 2023 (Agenda Item: 3.47)

Addenda: 1 (12/13/23), 2 (1/4/24)

Bids Open: 2 pm Date: Wednesday, January 17, 2024

BASE BID SCHEDULE - Lakepointe Drive Reconstruction					6 Hillcrest Contracting, Inc. Corona, CA 92879		7 IE General Engineering Inc. Beaumont, CA 92223	
ITEM NO.	ITEM CODE	CONTRACT ITEM	UNITS	QUANTITY	BID UNIT PRICE	BID ESTIMATE	BID UNIT PRICE	BID ESTIMATE
1	066100	DUST ABATEMENT	LS	1	41,000.00	41,000.00	20,000.00	20,000.00
2	100100	DEVELOP WATER SUPPLY	LS	1	12,500.00	12,500.00	10,000.00	10,000.00
3	120100	TRAFFIC CONTROL SYSTEM	LS	1	166,000.00	166,000.00	100,000.00	100,000.00
4	130200	PREPARE WATER POLLUTION CONTROL PROGRAM	LS	1	18,700.00	18,700.00	10,000.00	10,000.00
5	170103	CLEARING AND GRUBBING	LS	1	150,000.00	150,000.00	20,000.00	20,000.00
6	190101(F)	ROADWAY EXCAVATION	CY	3,891	75.00	291,825.00	62.00	241,242.00
7	260203	CLASS 2 AGGREGATE BASE	CY	390	173.00	67,470.00	160.00	62,400.00
8	198215	SUBGRADE ENHANCEMENT GEOGRID	SQYD	2,330	6.70	15,611.00	9.00	20,970.00
9	729011	ROCK SLOPE PROTECTION FABRIC (CLASS 8)	SQYD	468	5.50	2,574.00	8.00	3,744.00
10	680287	3" SLOTTED PLASTIC PIPE UNDERDRAIN [SCH 80]	LF	545	190.00	103,550.00	50.00	27,250.00
11	681107	3" PLASTIC PIPE (EDGE DRAIN OUTLET) [SCH 80]	LF	40	264.00	10,560.00	100.00	4,000.00
12	710212	ADJUST MANHOLE TO GRADE [STORM DRAIN]	EA	12	1,460.00	17,520.00	3,200.00	38,400.00
13	720110	SMALL-ROCK SLOPE PROTECTION [PERMEABLE MATERIAL - CRUSHED ROCK]	CY	23	165.00	3,795.00	350.00	8,050.00
14	390132	HOT MIX ASPHALT (TYPE A)	TON	7,647	130.00	994,110.00	219.00	1,674,693.00
15	731521	MINOR CONCRETE (SIDEWALK)	SQFT	874	10.30	9,002.20	6.00	5,244.00
15.A	017315	MINOR CONCRETE (CURB RAMP) (CRS 403 - CASE A)	EA	16	6,500.00	104,000.00	12,000.00	192,000.00
15.B	017317	MINOR CONCRETE (CROSS-GUTTER AND SPANDREL)	SQFT	2,980	25.60	76,288.00	15.00	44,700.00
16	017304	MINOR CONCRETE (CURB AND GUTTER) (CRS 200)	LF	30	55.00	1,650.00	75.00	2,250.00

**Riverside County Transportation Department
Summary of Bids**

**PROJECT: Lakepointe Drive Reconstruction
Indiana Avenue to Southern Sun Summit Drive
Community of Lake Hills
Project No. D2-0049**

Advertised: November 28, 2023 (Agenda Item: 3.47)

Addenda: 1 (12/13/23), 2 (1/4/24)

Bids Open: 2 pm Date: Wednesday, January 17, 2024

BASE BID SCHEDULE - Lakepointe Drive Reconstruction (continued)					6 Hillcrest Contracting, Inc. Corona, CA 92879		7 IE General Engineering Inc. Beaumont, CA 92223	
ITEM NO.	ITEM CODE	CONTRACT ITEM	UNITS	QUANTITY	BID UNIT PRICE	BID ESTIMATE	BID UNIT PRICE	BID ESTIMATE
17	017310	MINOR CONCRETE (DRIVEWAY APPROACH) (CRS 207)	SQFT	400	14.40	5,760.00	9.00	3,600.00
18	000001	ITEM DELETED PER ADDENDUM No. 2	----	----	----	----	----	----
19	820410	SALVAGE ROADSIDE SIGN	EA	16	110.00	1,760.00	110.00	1,760.00
20	820840	ROADSIDE SIGN - ONE POST	EA	20	410.00	8,200.00	415.00	8,300.00
21	810230(F)	PAVEMENT MARKER (RETROREFLECTIVE)	EA	370	9.30	3,441.00	10.00	3,700.00
22	840519	THERMOPLASTIC CROSSWALK AND PAVEMENT MARKING	SQFT	905	6.30	5,701.50	6.50	5,882.50
23	840656(F)	PAINT TRAFFIC STRIPE (2-COAT)	LF	4,620	0.83	3,834.60	1.00	4,620.00
24	010602	MISCELLANEOUS WORK (AS DIRECTED)	FA	1	85,000.00	85,000.00	85,000.00	85,000.00
BASE BID SCH - SUB-TOTAL ITEMS 1 - 24						2,199,852.30		2,597,805.50

ALTERNATIVE BID SCHEDULE 1 - Western Municipal Water District (WMWD) Facility Adjustments

ITEM NO.	ITEM CODE	CONTRACT ITEM	UNITS	QUANTITY	BID UNIT PRICE	BID ESTIMATE	BID UNIT PRICE	BID ESTIMATE
25	710228	ADJUST SEWER MANHOLE	EA	16	1,460.00	23,360.00	3,500.00	56,000.00
ALT BID SCH 1 - SUB-TOTAL ITEM 25						23,360.00		56,000.00

PROJECT TOTAL ITEMS 1 - 25					2,223,212.30	2,653,805.50
---------------------------------------	--	--	--	--	---------------------	---------------------



Patty Romo
Interim Director
of Transportation

COUNTY OF RIVERSIDE

TRANSPORTATION AND LAND MANAGEMENT AGENCY

Mojahed Salama, P.E.
Deputy for Transportation/Capital
Projects

Russell Williams
Deputy for Transportation/Planning and
Development

Transportation Department

ADDENDUM NUMBER 1

Dated December 13, 2023

to the
Specifications and Contract Documents
for the construction of

Lakepointe Drive Reconstruction
Indiana Avenue to Southern Sun Summit Drive
Community of Lake Hills
Project No. D2-0049

Bids Due: (Revised)
Wednesday, January 10, 2024; 2:00 p.m.
14th Street Transportation Annex
3525 14th Street; Riverside, CA 92501
(951) 955-6780

This Addendum is issued pursuant to the Instructions to Bidders, Item No. 8, of the Contract Documents for the reference project. This Addendum is issued as a supplement to the specification and special provisions for the referenced project. The revisions to the specifications shall become a part of the Contract Documents, and each bidder shall acknowledge receipt thereof on the Bid (Proposal). Bidders are directed to sign this addendum as acknowledged and attach the signed addendum to the contractor's submitted proposal.

Note: During the advertisement period of this project, this document and attachments (if any) are available upon request at the office of the Transportation Department, and are available as a free download at the Transportation Department's website:

<https://trans.rctlma.org/notices-inviting-bids>

MODIFICATIONS / CLARIFICATIONS TO SPECIAL PROVISIONS:

Item 1: The new designated date and time for the receipt and opening of bids is revised as follows:

Wednesday, January 10, 2024; 2:00 p.m.
14th Street Transportation Annex
3525 14th Street; Riverside, CA 92501
(951) 955-6780

Prepared by: _____ Date: 12/13/2023

Joel Jimenez, Project Manager, Contracts/Bidding Unit

Acknowledged: _____ Date: _____

(Contractor)

JRJ:jjr



*Patricia Romo
Interim Director
of Transportation*

COUNTY OF RIVERSIDE

TRANSPORTATION AND LAND MANAGEMENT AGENCY

*Dennis Acuna, P.E.
Deputy for Transportation Capital
Projects*

*Russell Williams
Deputy for Transportation Planning and
Development*

Transportation Department

ADDENDUM NUMBER 2

Dated January 4, 2024

**to the
Specifications and Contract Documents
for the construction of**

**Lakepointe Drive Reconstruction
Indiana Avenue to Southern Sun Summit Drive
Community of Lake Hills
Project No. D2-0049**

**Bids Due: (Revised)
Wednesday, January 17, 2024; 2:00 p.m.
14th Street Transportation Annex
3525 14th Street; Riverside, CA 92501
(951) 955-6780**

This Addendum is issued pursuant to the Instructions to Bidders, Item No. 8, of the Contract Documents for the reference project. This Addendum is issued as a supplement to the specification and special provisions for the referenced project. The revisions to the specifications shall become a part of the Contract Documents, and each bidder shall acknowledge receipt thereof on the Bid (Proposal). Bidders are directed to sign this addendum as acknowledged and attach the signed addendum to the contractor's submitted proposal.

Note: During the advertisement period of this project, this document and attachments (if any) are available upon request at the office of the Transportation Department, and are available as a free download at the Transportation Department's website:

<https://trans.rctlma.org/notices-inviting-bids>

MODIFICATIONS / CLARIFICATIONS TO SPECIAL PROVISIONS:

Item 1: The new designated date and time for the receipt and opening of bids is revised as follows:

**Wednesday, January 17, 2024; 2:00 p.m.
14th Street Transportation Annex
3525 14th Street; Riverside, CA 92501
(951) 955-6780**

Item 2: Revised Proposal. Refer to "Proposal" pages B2-B3. Delete and replace "Proposal" (pages B2 through B3) with "Proposal (Revised)" attached herewith as **Attachment "A"**. The following changes have been made to the Proposal:

Note: Revisions made to the proposal are written with blue font / blue numbers in Attachment "A".

a. Estimated Quantities have been revised for the following bid items:

Item 6, ROADWAY EXCAVATION
Item 14, HOT MIX ASPHALT (TYPE A)
Item 15, MINOR CONCRETE (SIDEWALK)

b. The following bid items have been added:

- Item 15.A, MINOR CONCRETE (CURB RAMP) (CRS 403 - CASE A)
- Item 15.B, MINOR CONCRETE (CROSS-GUTTER AND SPANDREL)

c. The following bid item has been deleted:

- Item 18, DETECTABLE WARNING SURFACE

Item 3: Concrete Items To Be Constructed

Refer to Section 73, "Concrete Curbs and Sidewalks", on pages 48 through 50 of the special provisions. Delete Section 73, "Concrete Curbs and Sidewalks", and replace it with the following:

73 CONCRETE CURBS AND SIDEWALKS

Add to Section 73-1.01 General:

73-1.01 GENERAL

Minor Concrete Items to be constructed are:

Driveway Approach, Sidewalk, Curb and Gutter, Curb Ramps, and Cross-Gutter and Spandrels

These minor concrete structures shall be constructed in accordance with the County Road Improvement Standards and Specifications or as directed by the Engineer and in conformance with Section 51, 73 and 90 of Standard Specifications, except as modified.

The cementitious material content of concrete must be at least 505 pounds per cubic yard for:
Driveway Approach, Sidewalk, Curb and Gutter, and Curb Ramps

The cementitious material content of concrete must be at least 590 pounds per cubic yard for:
Cross-Gutter and Spandrels

Add to Section 73-1.02B Detectable Warning Surfaces:

73-1.02B Detectable Warning Surfaces (Truncated Domes)

This work includes installing detectable warning surfaces on the curb ramps or on the areas as shown and specified on the plans, in conformance with section 73-1.02B, Section 73-3, and Section 73-3.01D(2) of Standard Specifications, Standard Plans, these Special Provisions, and as directed by the Engineer.

The curb ramp detectable warning surface will be a rigid polymer composite/fiberglass panel set into wet concrete for new ramp construction.

The color of the detectable warning surfaces will be yellow complying with Federal Standard 595B, Color No. 33538.

The manufacturer must provide a written 5-year warranty for detectable warning surface, guaranteeing replacement when there is defect in the dome shape, color fastness, sound-on-cane acoustic quality, resilience, or attachment. The warranty period will begin upon acceptance of the contract.

Installation of curb ramp detectable warning surface must comply with the manufacturer's recommendations.

Payment:

For New/Reconstructed Ramps:

Full compensation for Detectable Warning Surfaces (Truncated Dome Panels) shall be paid per considered as included in the contract unit price paid per each for Minor Concrete (Curb Ramp), and shall include full compensation for furnishing all labor, materials, tools, equipment and incidentals for doing all work involved in installing detectable warning surface, complete in place, as shown and specified on the plans, as specified in the Standard Specifications, these Special Provisions, and as directed by the Engineer, and no additional payment will be made therefor.

73-1.03 CONSTRUCTION

Add to Section 73-1.03 Construction:

Preparation of subgrade for the concrete structures shall be done in conformance with the requirements of Section 73-1.03B Subgrade Preparation of the Standard Specifications.

Excess material resulting from the excavation of the subgrade shall be disposed of as provided in Section 00-1.14, 'Disposal of Excess Excavation Or Materials', of these Special Provisions.

Full compensation for the removal of existing minor concrete structures (Driveway Approach, Sidewalk, Curb and Gutter, Curb Ramps, and Cross-Gutter and Spandrels) shall be considered as included in the contract bid prices for such minor concrete structures.

The Contractor is responsible for meeting requirements of American with Disabilities Act (ADA), the current edition of the California Building Code, and the draft and final versions of the Accessibility Guidelines for Pedestrian Facilities within the Public Right of Way as published by the United States Access Board.

Construction of minor concrete items shall include, but not be limited to, the following:

- 1) Removal and disposal of existing Driveway Approach, Sidewalk, Curb and Gutter, Curb Ramps, and Cross-Gutter and Spandrels and existing soil and aggregate as required;
- 2) Removal and disposal of existing asphalt, curb, and curb and gutter as required to match new grade within right of way at private access road/driveway.
- 3) Establishing grades, and assuring that all grades are met;
- 4) Performing all grading and compaction – including all required aggregate import, as directed by the Engineer and in accordance with County Standards;
- 5) Construction of new minor concrete items;
- 6) All scoring/grooving and required saw cutting;
- 7) Repair of existing asphalt and PCC surfacing adjacent to minor concrete items, including slot cuts in front or around Minor Concrete items;
 - Surface repairs shall consist of replacing aggregate base over HMA in kind to match existing roadway structural section or as shown on the plans.
 - Alternatively, if approved by the Engineer, surface repairs can be 2-sack slurry cement backfill then cap with HMA, or a deep lift of HMA.
 - Reconstruction of asphalt concrete, curb, and curb and gutter within right-of-way as needed to match in existing private access road/driveway to new driveway grade.
- 8) Installing 1/2" wide expansion joints;
- 9) All landscaping, and related work, to return the area adjacent to the minor concrete items to its original condition and to conform the area to the new improvements;

At a minimum, the area from the BCR to ECR shall meet all required ADA standards. Therefore, to conform to existing conditions and/or to achieve the required four-foot level area (as-built maximum of

2.00% crossfall) at the top portion of the curb ramp, it may be necessary to extend the work beyond the BCR/ECR in certain instances.

The area behind and along the Curb and Gutter shall be filled and compacted with native or select material and graded to match and provide a smooth transition from the back of sidewalk and curb return to the satisfaction of the Engineer.

Replace Section 73-1.04 Payment:

Payment:

The contract unit bid prices paid per square foot for Minor Concrete (Driveway Approach) (CRS 207), Minor Concrete (Sidewalk), and Minor Concrete (Cross-Gutter and Spandrels); per linear foot for Minor Concrete (Curb and Gutter) (CRS 200); and per each for Minor Concrete (Curb Ramp) (CRS 403 – Case A); shall include full compensation for furnishing all labor, equipment, materials and tools, and incidentals, and for doing all the work involved in the concrete structures construction including the grading and the removal of any obstacles within the areas of proposed concrete items of work including excavation, backfill, the furnishing and placing of expansion joints, reconstruction of curb, curb/gutter, and pavement to match new driveway grade, installation of detectable warning surfaces (truncated domes), furnishing and placing temporary steel plates, complete in place as shown on the plans, as specified in the Standard Specifications and these Special Provisions, and as directed by the Engineer and no additional compensation will be allowed therefor.

Item 4: Addition of Reference Drawing

Refer to Appendix B, Reference Drawings, of the Special Provisions. The following reference drawing is added by **Attachment "C"** and made part hereby:

- County Std. 209 for Cross Gutter and Spandrel

MODIFICATIONS / CLARIFICATIONS TO THE PLANS

Item 5: Plan sheet revisions and additions.

Refer to Plans for Lakepointe Drive Reconstruction, Indiana Avenue to Southern Sun Summit Drive, Community of Lake Hills, Project No. D2-0049.

The following Plan sheets are revised and/or added by **Attachment "B" and made a part hereby.**

- **Delete sheets 1 through 8 of 8 and replace** them with the following thirteen (13) plans sheets:

- | | |
|----------------------------|-------------------------------|
| 1. Plan sheet T, 1 of 13 | 8. Plan sheet C-3, 8 of 13 |
| 2. Plan sheet X-1, 2 of 13 | 9. Plan sheet C-4, 9 of 13 |
| 3. Plan sheet L-1, 3 of 13 | 10. Plan sheet C-5, 10 of 13 |
| 4. Plan sheet L-2, 4 of 13 | 11. Plan sheet PD-1, 11 of 13 |
| 5. Plan sheet L-3, 5 of 13 | 12. Plan sheet PD-2, 12 of 13 |
| 6. Plan sheet C-1, 6 of 13 | 13. Plan sheet PD-3, 13 of 13 |
| 7. Plan sheet C-2, 7 of 13 | |

The updated plans now include reconstruction of concrete Curb Ramps, Cross Gutters and Spandrels.

Plan sheets C1 through C5 (6 through 10 of 13) are added to include details for reconstruction of concrete Curb Ramps.

Note: Revised plan sheet(s) is (are) posted on the County website and available for download during the advertisement period.

<https://trans.rctlma.org/notices-inviting-bids>

ATTACHMENTS

A – Revised Proposal (2 pages)

B – Revised / Added Plan Sheets (13 sheets)

C – Reference Drawing (2 pages)

This addendum has been prepared under the direction of the following registered Civil Engineer(s):

Recommended by:

Mike Heath

Mike Heath, PE
Engineering Project Manager



Concurrence:

Dennis Acuna, PE, TE
Deputy Director

Acknowledged: _____ **Date:** _____
(Contractor)

JRJ: jrj:jr

Note: Refer to Instruction to Bidders Item No. 8, "Addenda". Submission of all addendum pages and non-bidding document attachments of addendum are not necessary for Bid submittal. Submittal of this acknowledgement page is adequate for Bid reception. Bidders are reminded to list addendum number(s) received on the first page of the Bid form (Proposal).

**Lakepointe Drive Reconstruction
Indiana Avenue to Southern Sun Summit Drive
Community of Lake Hills
Project No. D2-0049**

REVISED PROPOSAL

ITEM No.	ITEM CODE	ITEM	UNIT	ESTIMATED QUANTITY	ITEM PRICE (IN FIGURES)	TOTAL (IN FIGURES)
----------	-----------	------	------	--------------------	-------------------------	--------------------

BASE BID SCHEDULE - Lakepointe Drive Reconstruction

1	066100	DUST ABATEMENT	LS	1		
2	100100	DEVELOP WATER SUPPLY	LS	1		
3	120100	TRAFFIC CONTROL SYSTEM	LS	1		
4	130200	PREPARE WATER POLLUTION CONTROL PROGRAM	LS	1		
5	170103	CLEARING AND GRUBBING	LS	1		
6	190101(F)	ROADWAY EXCAVATION	CY	3,891		
7	260203	CLASS 2 AGGREGATE BASE	CY	390		
8	198215	SUBGRADE ENHANCEMENT GEOGRID	SQYD	2,330		
9	729011	ROCK SLOPE PROTECTION FABRIC (CLASS 8)	SQYD	468		
10	680287	3" SLOTTED PLASTIC PIPE UNDERDRAIN [SCH 80]	LF	545		
11	681107	3" PLASTIC PIPE (EDGE DRAIN OUTLET) [SCH 80]	LF	40		
12	710212	ADJUST MANHOLE TO GRADE [STORM DRAIN]	EA	12		
13	720110	SMALL-ROCK SLOPE PROTECTION [PERMEABLE MATERIAL - CRUSHED ROCK]	CY	23		
14	390132	HOT MIX ASPHALT (TYPE A)	TON	7,647		
15	731521	MINOR CONCRETE (SIDEWALK)	SQFT	874		
15.A	017315	MINOR CONCRETE (CURB RAMP) (CRS 403 - CASE A)	EA	16		
15.B	017317	MINOR CONCRETE (CROSS-GUTTER AND SPANDREL)	SQFT	2,980		
16	017304	MINOR CONCRETE (CURB AND GUTTER) (CRS 200)	LF	30		
17	017310	MINOR CONCRETE (DRIVEWAY APPROACH) (CRS 207)	SQFT	400		

ITEM No.	ITEM CODE	ITEM	UNIT	ESTIMATED QUANTITY	ITEM PRICE (IN FIGURES)	TOTAL (IN FIGURES)
----------	-----------	------	------	--------------------	-------------------------	--------------------

BASE BID SCHEDULE - Lakepointe Drive Reconstruction (Continued)

18	000001	ITEM DELETED PER ADDENDUM No. 2	-----	-----	-----	-----
19	820410	SALVAGE ROADSIDE SIGN	EA	16		
20	820840	ROADSIDE SIGN - ONE POST	EA	20		
21	810230(F)	PAVEMENT MARKER (RETROREFLECTIVE)	EA	370		
22	840519	THERMOPLASTIC CROSSWALK AND PAVEMENT MARKING	SQFT	905		
23	840656(F)	PAINT TRAFFIC STRIPE (2-COAT)	LF	4,620		
24	010602	MISCELLANEOUS WORK (AS DIRECTED)	FA	1	85,000.00	85,000.00

BASE BID SCH.
TOTAL: _____ \$ _____
ITEMS 1-24 "WORDS"

ALTERNATIVE BID SCHEDULE 1 - Western Municipal Water District (WMWD) Facility Adjustments

25	710228	ADJUST SEWER MANHOLE	EA	16		
----	--------	----------------------	----	----	--	--

ALT. BID SCH. 1
TOTAL: _____ \$ _____
ITEM 25 "WORDS"

BASE BID SCH. + ALT. BID SCH. 1

PROJECT
TOTAL: _____ \$ _____
ITEMS 1 - 25 "WORDS"

STRIPING NOTES:

- ◻ 22 PAINT NO PASSING ZONES-TWO DIRECTION STRIPES AND INSTALL MARKERS PER CALTRANS STD A20A, DETAIL 22
- ◻ LL INSTALL THERMOPLASTIC LIMIT LINE PER CALTRANS STD A24D AT LEAST 24" FROM CROSS-GUTTERS
- ◻ PM INSTALL THERMOPLASTIC PAVEMENT MARKINGS AS SHOWN PER CALTRANS STD A24A THROUGH A24D FOR ARROWS, SYMBOLS, AND WORDS, WHITE EXCEPT NOTED OTHERWISE

SIGNING NOTES:

- ◻ P PROTECT SIGN
- ◻ RS REMOVE/SALVAGE SIGN
- ◻ IS INSTALL SIGN (STD No. 1220 TO BE USED WHEN INSTALLING SNS)

SIGN SIZE

SW4-1(CA)	48" x 48"
SNS	VARIES
R1-1	36" x 36"
R1-3P	18" x 6"
W3-1	36" x 36"
W16-2aP (500 FT)	24" x 12"

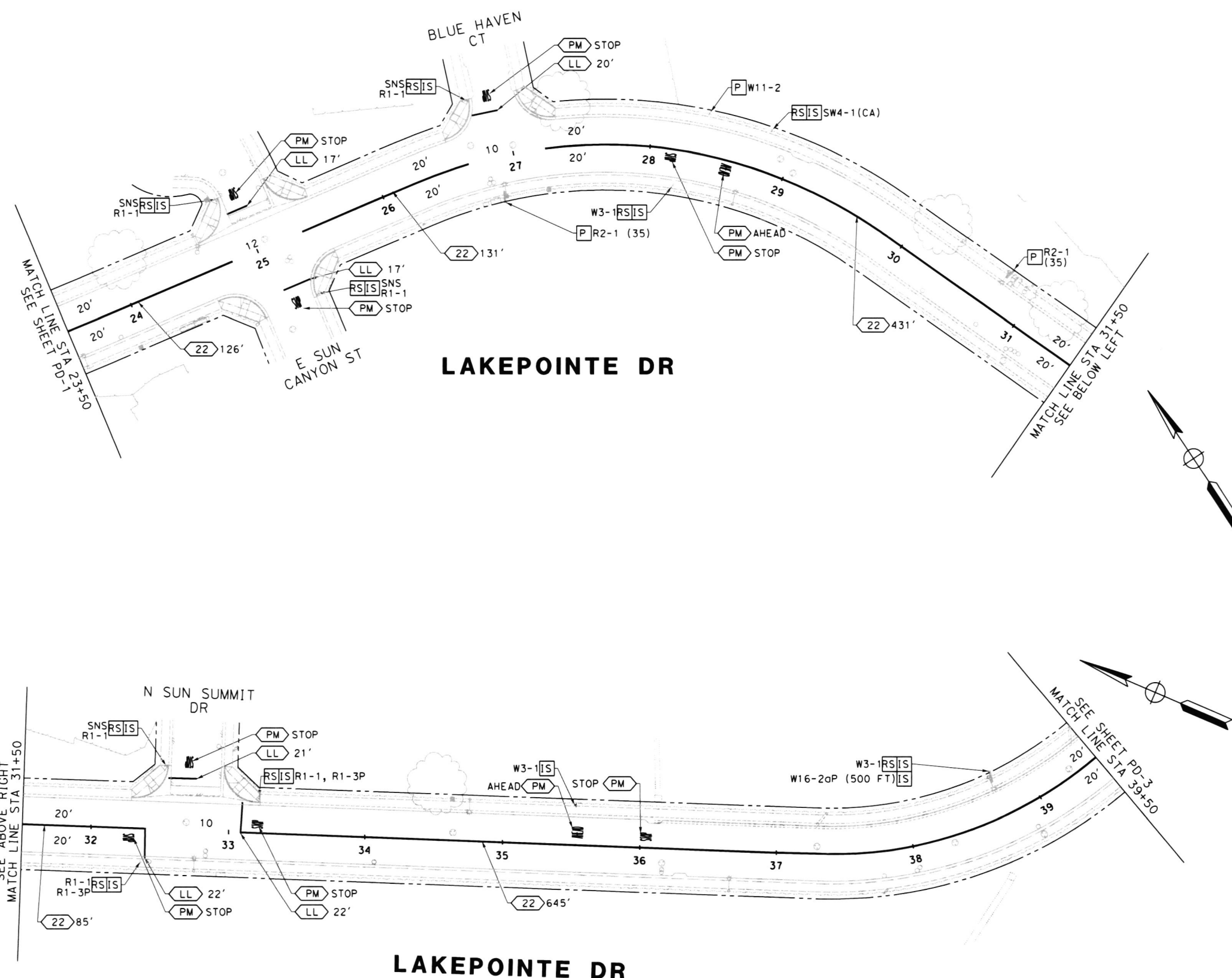

BORDER LAST REVISED 3/30/2021

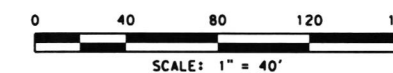

<p>PREPARED BY</p> <p>PREPARED UNDER THE SUPERVISION OF:</p> <p>DENNIS ACUNA No. 73955 CIVIL STATE OF CALIFORNIA</p>	<p>PAVEMENT DELINEATION & SIGNING</p> <p>LAKEPOINTE DR RECONSTRUCTION PROJECT</p> <p>STA 23+50 TO 39+50</p>	<p>SHEET No.</p> <p>PD-2</p> <p>SHEET 12 of 13</p>
---	---	--

USERNAME => RAlhadeethi
DGN FILE => D2-0049 na PD-02.sht
WO D2-0049
COUNTY FILE No. **973-W**

ISSUED BY ADDENDUM No. 2, ATTACHMENT "B"
DATE PLOTTED => 1/3/2024
TIME PLOTTED => 8:48:10 AM
LAST REVISION 12-05-23

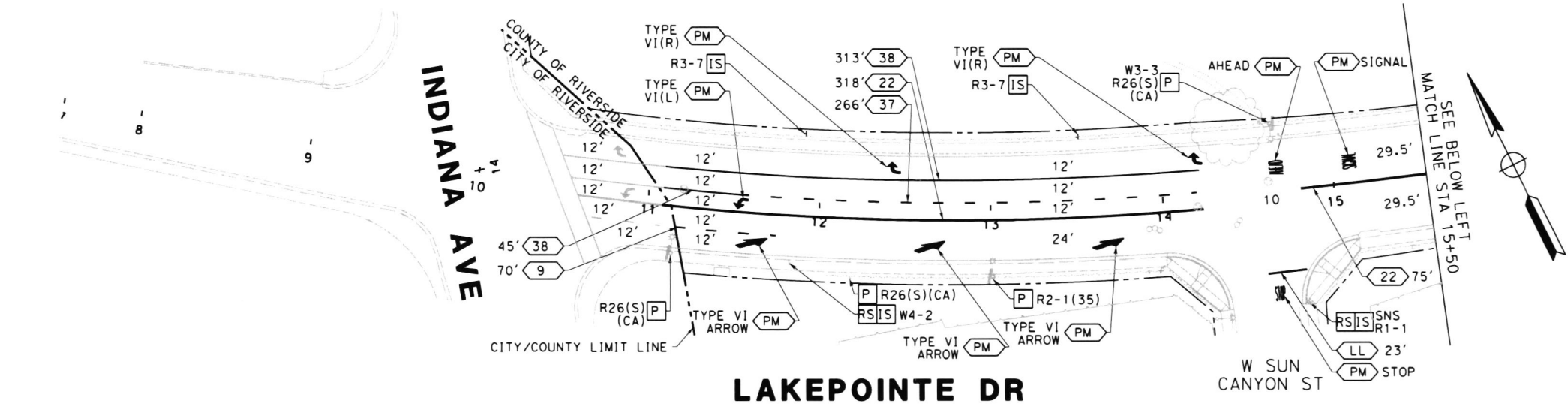

- STRIPING NOTES:**
- 9 PAINT LANELINES STRIPE AND INSTALL MARKERS PER CALTRANS STD A20A, DETAIL 9
 - 22 PAINT NO PASSING ZONES-TWO DIRECTION STRIPES AND INSTALL MARKERS PER CALTRANS STD A20A, DETAIL 22
 - 37 PAINT LANE DROP AT EXIT RAMP STRIPES AND INSTALL MARKERS PER CALTRANS STD A20C, DETAIL 37
 - 38 PAINT CHANNELIZING LINE STRIPE AND INSTALL MARKERS PER CALTRANS STD A20D, DETAIL 38
 - LL INSTALL THERMOPLASTIC LIMIT LINE PER CALTRANS STD A24D AT LEAST 24" FROM CROSS-GUTTERS
 - PM INSTALL THERMOPLASTIC PAVEMENT MARKINGS AS SHOWN PER CALTRANS STD A24A THROUGH A24D FOR ARROWS, SYMBOLS, AND WORDS, WHITE EXCEPT NOTED OTHERWISE

- SIGNING NOTES:**
- P PROTECT SIGN
 - RS REMOVE/SALVAGE SIGN
 - IS INSTALL SIGN (STD No. 1220 TO BE USED WHEN INSTALLING SNS)

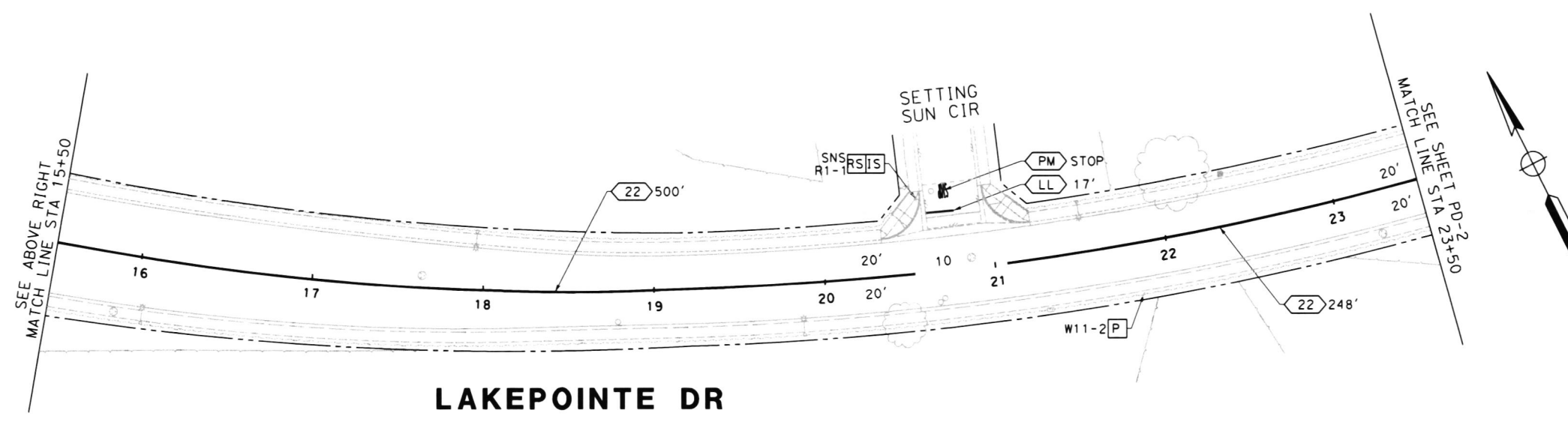

SIGN SIZE

W4-2	36" X 36"
SNS	VARIES
R1-1	36" X 36"
R3-7	36" X 36"

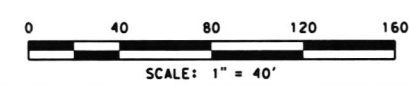

<p>PREPARED BY</p> <p>PREPARED UNDER THE SUPERVISION OF:</p> <p style="text-align: right;">01/03/2024</p> <p style="text-align: right;">DATE</p> <p>DENNIS ACUM ENGINEERING DIVISION MANAGER COUNTY OF RIVERSIDE</p>	<p>PAVEMENT DELINEATION & SIGNING SHEET No.</p> <p style="text-align: center;">LAKEPOINTE DR</p> <p style="text-align: center;">RECONSTRUCTION PROJECT</p> <p style="text-align: center;">STA 11+08 TO 23+50</p>	<p style="text-align: center; font-size: 2em;">PD-1</p> <p style="text-align: center;">SHEET 11 of 13</p>
---	--	--

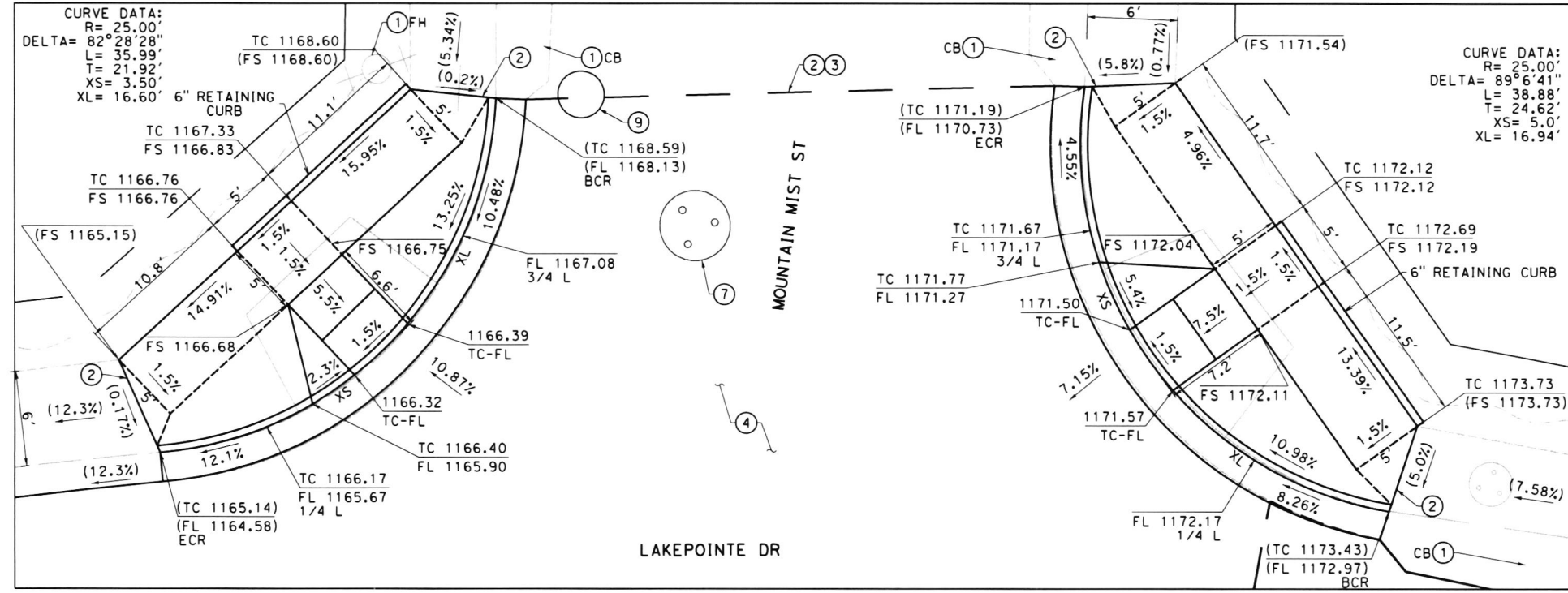

13 CURB RAMP DETAIL #13
ADA DESIGN EXCEPTION #0013
ON FILE FOR THIS CURB RAMP

13 CURB RAMP DETAIL #14
ADA DESIGN EXCEPTION #0014
ON FILE FOR THIS CURB RAMP

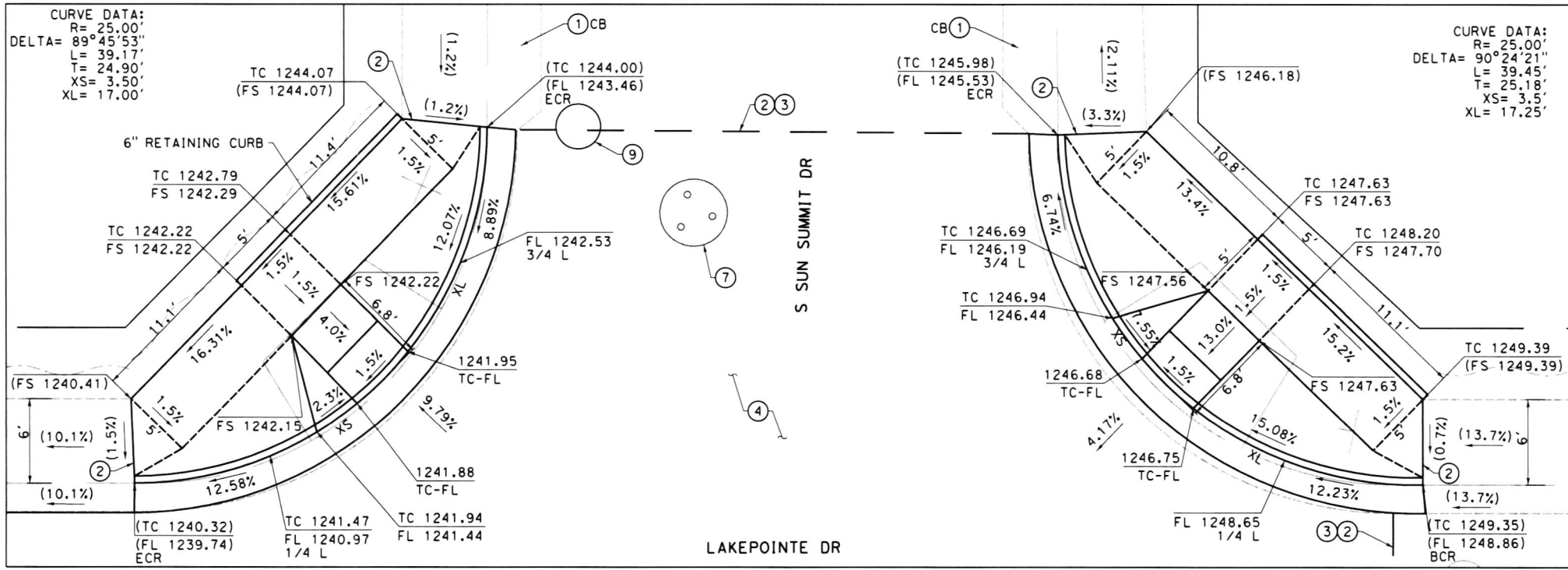
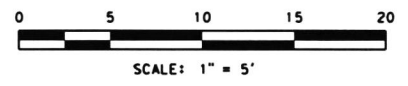

13 CURB RAMP DETAIL #15
ADA DESIGN EXCEPTION #0015
ON FILE FOR THIS CURB RAMP

13 CURB RAMP DETAIL #16
ADA DESIGN EXCEPTION #0016
ON FILE FOR THIS CURB RAMP

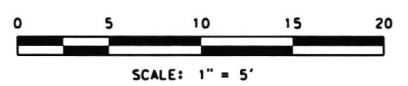

- CONSTRUCTION NOTES:**
- 1 PROTECT IN PLACE
 - 2 MATCH EXISTING
 - 3 SAWCUT
 - 4 EXCAVATE EXISTING ASPHALT CONCRETE AND UNDERLYING MATERIAL TO A DEPTH OF 0.45'; MOISTURE CONDITION, GRADE, AND RECOMPACT SUBGRADE TO 95%. CONSTRUCT 0.20" HMA (SUPERPAVE) TYPE "A" 3/4" MIX, PG 64-28M OVER 0.25" HMA (SUPERPAVE) TYPE "A" 1" MIX, PG 64-28M
 - 7 ADJUST STORM DRAIN MANHOLE TO GRADE BY CONTRACTOR
 - 9 ADJUST WATER VALVE TO GRADE BY CONTRACTOR
 - 13 RECONSTRUCT CONCRETE CURB RAMP PER STD No. 403 CASE "A" AND PER DETAIL SHEET C-1 THROUGH C-5

PREPARED BY
PREPARED UNDER THE SUPERVISION OF:
Mike Heath 1/03/2024
MIKE HEATH
ENGINEERING PROJECT MANAGER
COUNTY OF RIVERSIDE



CONSTRUCTION DETAILS
LAKEPOINTE DR
RECONSTRUCTION PROJECT

SHEET No.
C-5
SHEET 10 of 13

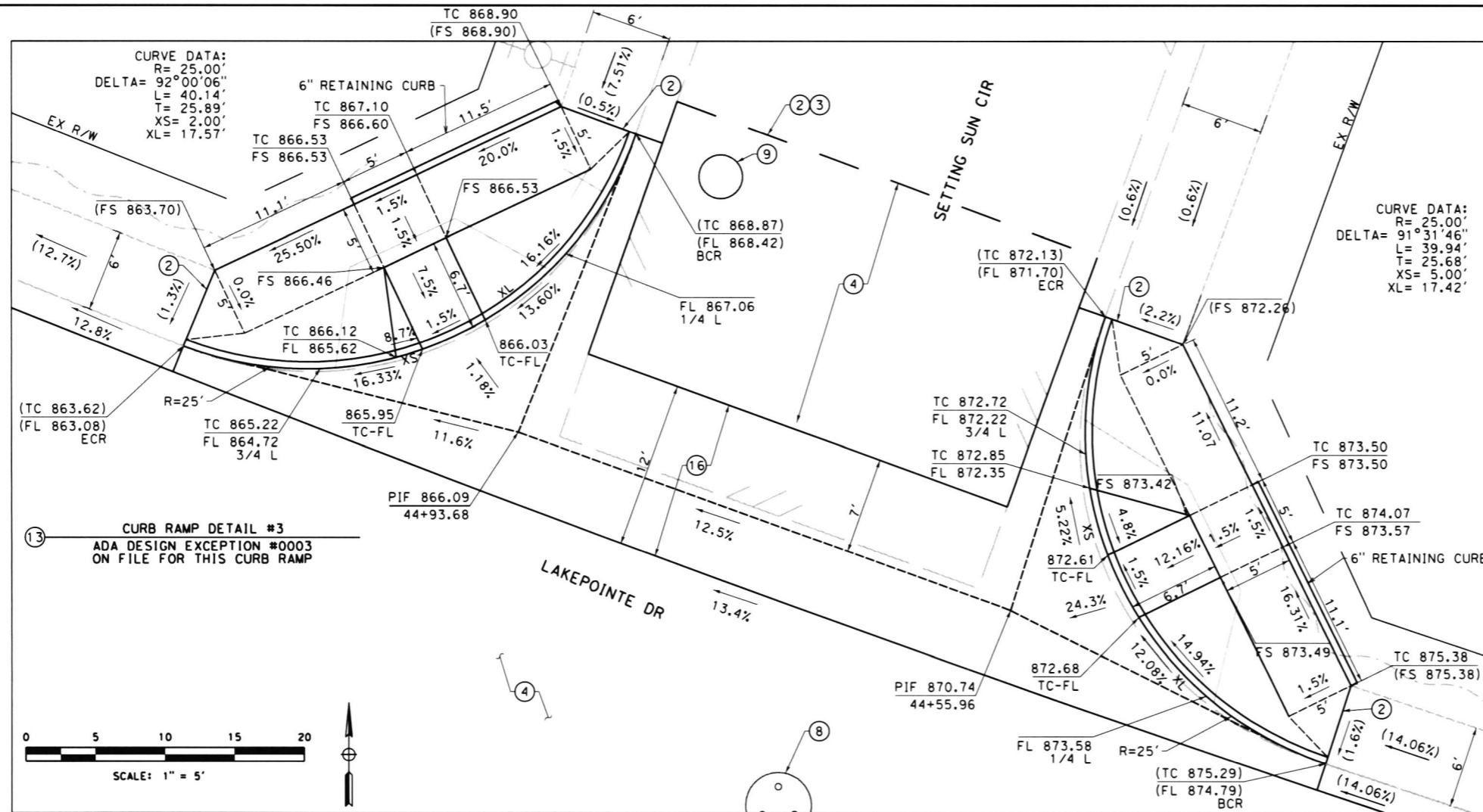

CONSTRUCTION NOTES:

- ① PROTECT IN PLACE
- ② MATCH EXISTING
- ③ SAWCUT
- ④ EXCAVATE EXISTING ASPHALT CONCRETE AND UNDERLYING MATERIAL TO A DEPTH OF 0.45'; MOISTURE CONDITION, GRADE, AND RECOMPACT SUBGRADE TO 95%. CONSTRUCT 0.20" HMA (SUPERPAVE) TYPE "A" 3/4" MIX, PG 64-28M OVER 0.25" HMA (SUPERPAVE) TYPE "A" 1" MIX, PG 64-28M
- ⑧ ADJUST SEWER MANHOLE TO GRADE BY WMWD
- ⑨ ADJUST WATER VALVE TO GRADE BY CONTRACTOR
- ⑬ RECONSTRUCT CONCRETE CURB RAMP PER STD. No. 403 CASE "A" AND PER DETAIL SHEET C-1 THROUGH C-5
- ⑯ RECONSTRUCT CONCRETE CROSS-GUTTER AND SPANDREL PER COUNTY STD. No. 209

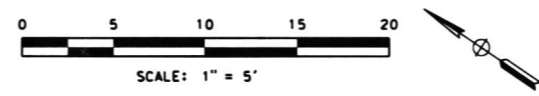
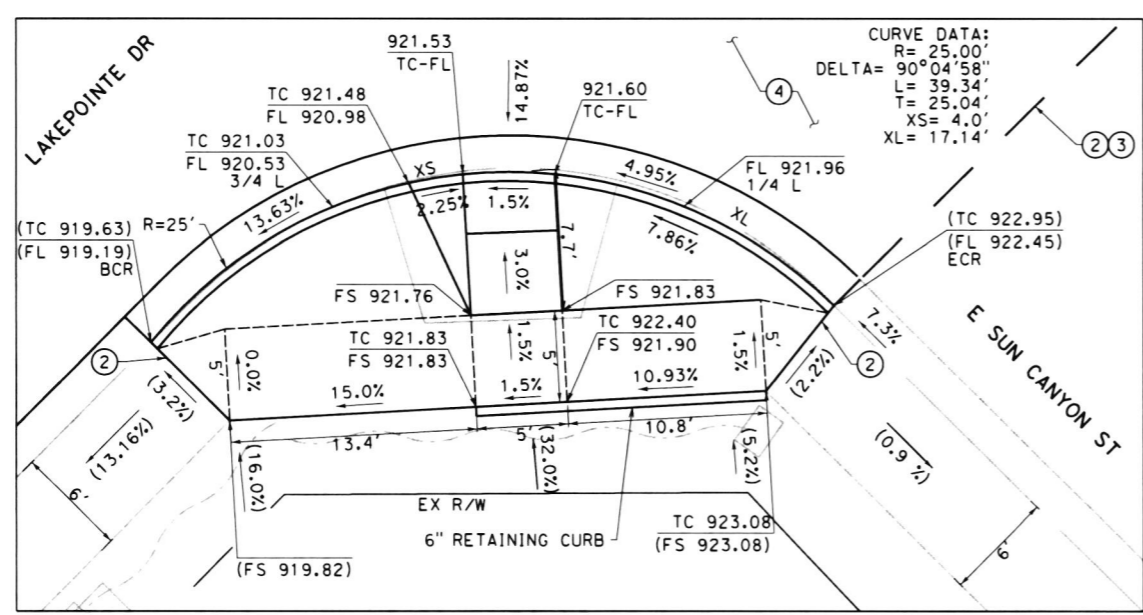

PREPARED BY  PREPARED UNDER THE SUPERVISION OF: <i>Mike Heath</i> 1/03/2024 MIKE HEATH ENGINEERING PROJECT MANAGER COUNTY OF RIVERSIDE	CONSTRUCTION DETAILS LAKEPOINTE DR RECONSTRUCTION PROJECT	SHEET No. C-2 SHEET 07 of 13
	USERNAME => RA\hadeethi DGN FILE => D2-0049 gaC-02.dgn	WO D2-0049

CONSTRUCTION NOTES:

- ① PROTECT IN PLACE
- ② MATCH EXISTING
- ③ SAWCUT
- ④ EXCAVATE EXISTING ASPHALT CONCRETE AND UNDERLYING MATERIAL TO A DEPTH OF 0.45', MOISTURE CONDITION, GRADE, AND RECOMPACT SUBGRADE TO 95%. CONSTRUCT 0.20' HMA (SUPERPAVE) TYPE "A" 3/4" MIX, PG 64-28M OVER 0.25' HMA (SUPERPAVE) TYPE "A" 1" MIX, PG 64-28M
- ⑥ EXCAVATE EXISTING ASPHALT CONCRETE AND UNDERLYING MATERIAL TO A DEPTH OF 0.95' (MIN.), MOISTURE CONDITION, GRADE, AND RECOMPACT SUBGRADE TO 95%. CONSTRUCT 0.20' HMA (SUPERPAVE) TYPE "A" 3/4" MIX, PG 64-28M OVER 0.25' HMA (SUPERPAVE) TYPE "A" 1" MIX, PG 64-28M OVER 0.50' CLASS II AGGREGATE BASE OVER GEOGRID. ADDITIONAL EXCAVATION MAY BE REQUIRED AS DIRECTED.
- ⑬ RECONSTRUCT CONCRETE CURB RAMP PER STD No. 403 CASE "A" AND PER DETAIL SHEET C-1 THROUGH C-5

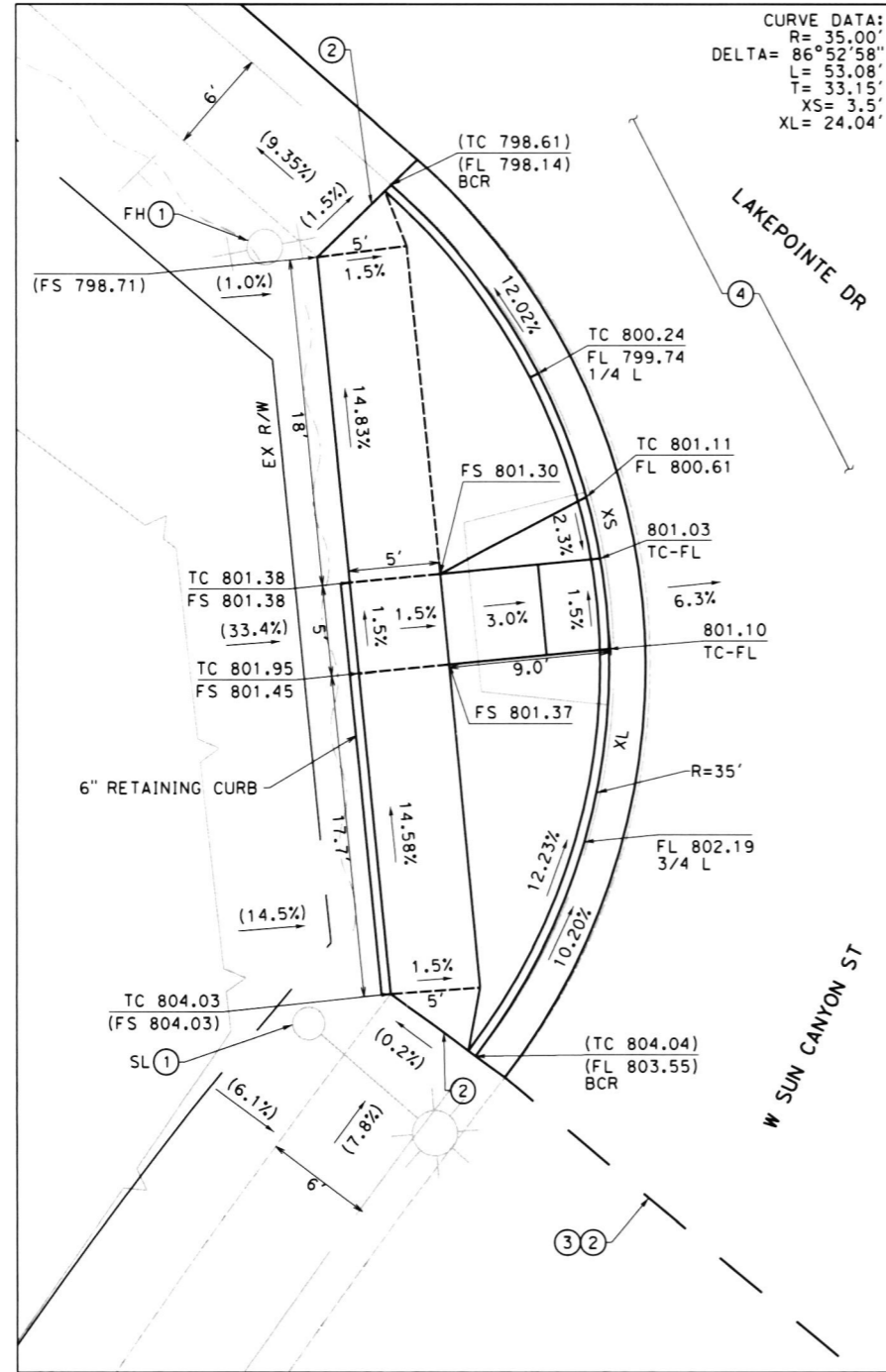

⑬ CURB RAMP DETAIL #1
ADA DESIGN EXCEPTION #0001
ON FILE FOR THIS CURB RAMP

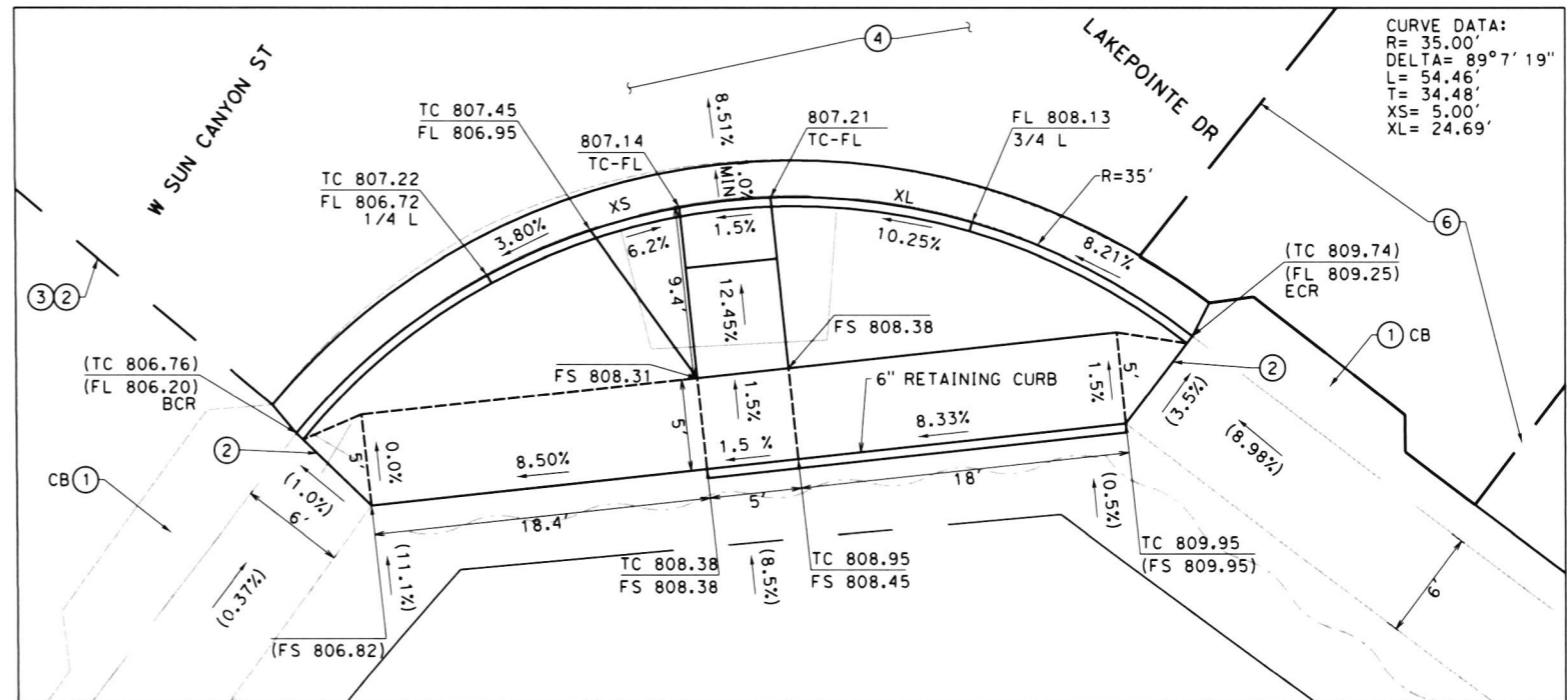

⑬ CURB RAMP DETAIL #2
ADA DESIGN EXCEPTION #0002
ON FILE FOR THIS CURB RAMP

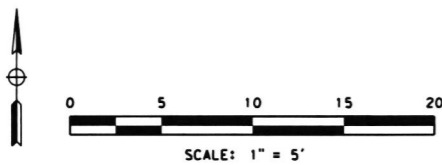

BORDER LAST REVISED 3/30/2021

	PREPARED BY	CONSTRUCTION DETAILS	SHEET No.
	PREPARED UNDER THE SUPERVISION OF: <i>Mike Heath</i> MIKE HEATH ENGINEERING PROJECT MANAGER COUNTY OF RIVERSIDE	LAKEPOINTE DR RECONSTRUCTION PROJECT	C-1 SHEET 06 of 13

USERNAME => RAihadeethi
 DGN FILE => D2-0049 gaC-01.dgn
 WO D2-0049
 COUNTY FILE No. **973-W**

ISSUED BY ADDENDUM No. 2, ATTACHMENT "B"

DATE PLOTTED => 1/3/2024
 TIME PLOTTED => 8:47:57 AM
 LAST REVISION
 12-05-23

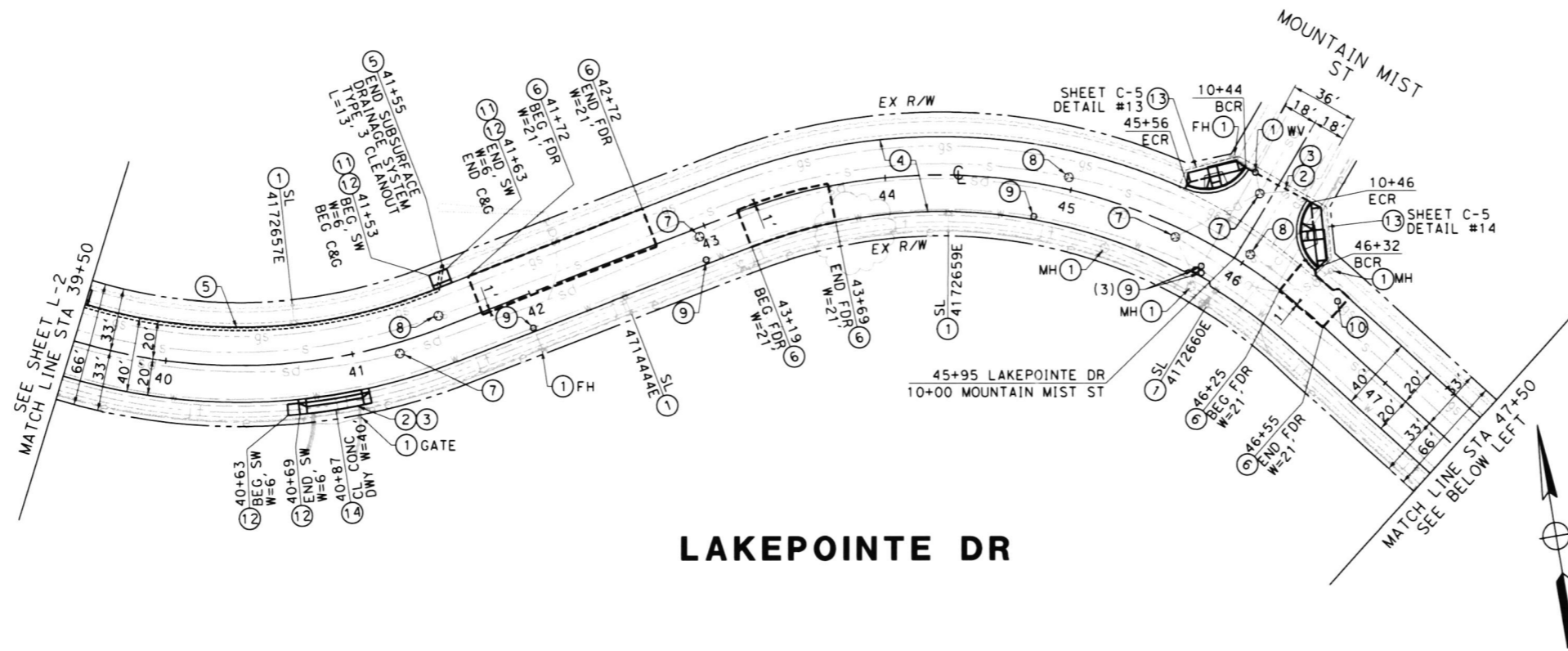

LAKEPOINTE DR

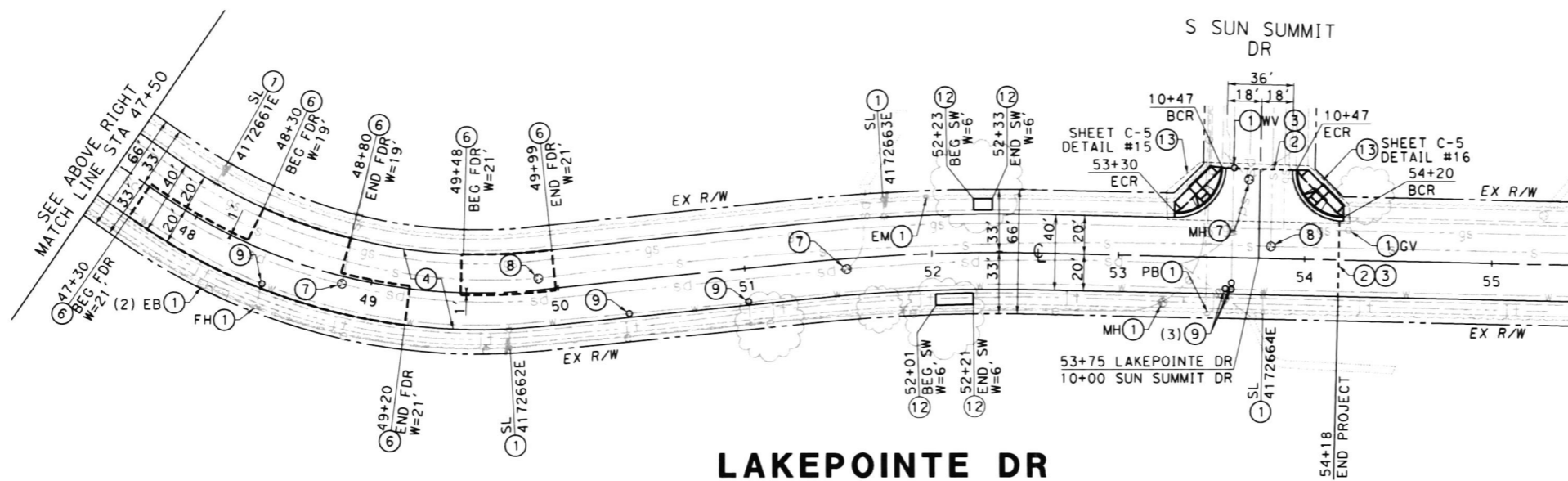



LAKEPOINTE DR

CONSTRUCTION NOTES:

- ① PROTECT IN PLACE
- ② MATCH EXISTING
- ③ SAWCUT
- ④ EXCAVATE EXISTING ASPHALT CONCRETE AND UNDERLYING MATERIAL TO A DEPTH OF 0.45', MOISTURE CONDITION, GRADE, AND RECOMPACT SUBGRADE TO 95%. CONSTRUCT 0.20' HMA (SUPERPAVE) TYPE "A" 3/4" MIX, PG 64-28M OVER 0.25' HMA (SUPERPAVE) TYPE "A" 1" MIX, PG 64-28M
- ⑤ CONSTRUCT SUBSURFACE DRAINAGE SYSTEM PER DETAILS ON SHEET X-1 AND PER CALTRANS STD P51 & P52
- ⑥ EXCAVATE EXISTING ASPHALT CONCRETE AND UNDERLYING MATERIAL TO A DEPTH OF 0.95' (MIN.), MOISTURE CONDITION, GRADE, AND RECOMPACT SUBGRADE TO 95%. CONSTRUCT 0.20' HMA (SUPERPAVE) TYPE "A" 3/4" MIX, PG 64-28M OVER 0.25' HMA (SUPERPAVE) TYPE "A" 1" MIX, PG 64-28M OVER 0.50' CLASS II AGGREGATE BASE OVER GEOGRID. ADDITIONAL EXCAVATION MAY BE REQUIRED AS DIRECTED.
- ⑦ ADJUST STORM DRAIN MANHOLE TO GRADE BY CONTRACTOR
- ⑧ ADJUST SEWER MANHOLE TO GRADE BY WMWD
- ⑨ ADJUST WATER VALVE TO GRADE BY CONTRACTOR
- ⑩ ADJUST GAS VALVE TO GRADE BY CONTRACTOR
- ⑪ RECONSTRUCT TYPE A-6 CONCRETE CURB AND GUTTER PER STD No. 200
- ⑫ RECONSTRUCT CONCRETE SIDEWALK PER STD No. 401
- ⑬ RECONSTRUCT CONCRETE CURB RAMP PER STD No. 403 CASE "A" AND PER DETAIL SHEET C-1 THROUGH C-5
- ⑭ RECONSTRUCT CONCRETE DRIVEWAY PER STD No. 207. RECONSTRUCT EXISTING ASPHALT CONCRETE, CONCRETE CURB, AND CONCRETE CURB & GUTTER WITHIN R/W AS NEEDED TO MATCH EXISTING PRIVATE ACCESS ROAD TO NEW DRIVEWAY GRADE

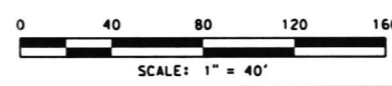
ISSUED BY ADDENDUM No. 2, ATTACHMENT "B"



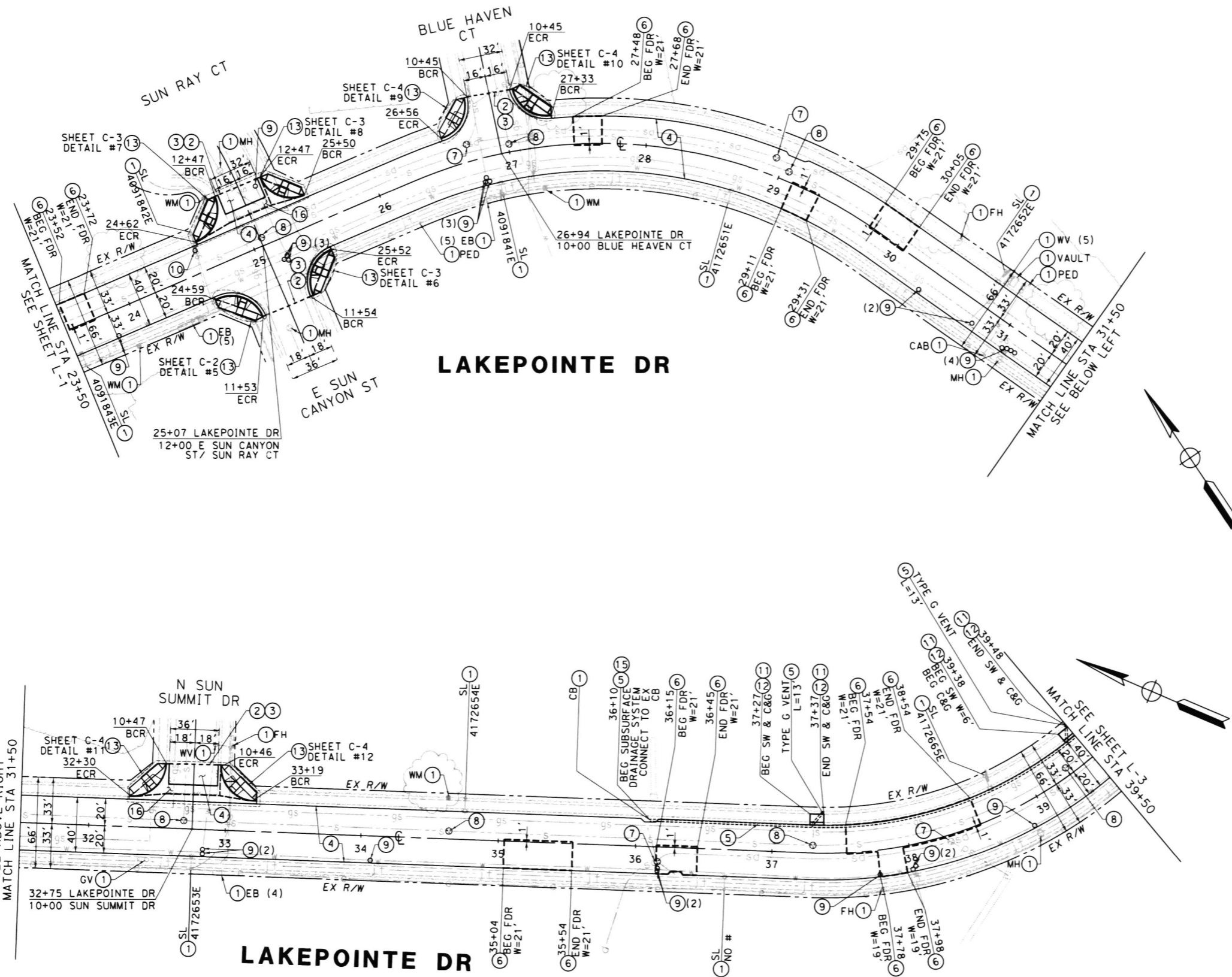

	PREPARED BY	LAYOUT	SHEET No.
	PREPARED UNDER THE SUPERVISION OF: <i>Mike Heath</i> 1/03/2024 MIKE HEATH ENGINEERING PROJECT MANAGER COUNTY OF RIVERSIDE	LAKEPOINTE DR RECONSTRUCTION PROJECT STA 39+50 TO 54+18	L-3 SHEET 05 of 13

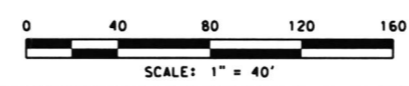

- CONSTRUCTION NOTES:**
- 1 PROTECT IN PLACE
 - 2 MATCH EXISTING
 - 3 SAWCUT
 - 4 EXCAVATE EXISTING ASPHALT CONCRETE AND UNDERLYING MATERIAL TO A DEPTH OF 0.45'. MOISTURE CONDITION, GRADE, AND RECOMPACT SUBGRADE TO 95%. CONSTRUCT 0.20' HMA (SUPERPAVE) TYPE "A" 3/4" MIX, PG 64-28M OVER 0.25' HMA (SUPERPAVE) TYPE "A" 1" MIX, PG 64-28M
 - 5 CONSTRUCT SUBSURFACE DRAINAGE SYSTEM PER DETAILS ON SHEET X-1 AND PER CALTRANS STD P51 & P52
 - 6 EXCAVATE EXISTING ASPHALT CONCRETE AND UNDERLYING MATERIAL TO A DEPTH OF 0.95' (MIN.). MOISTURE CONDITION, GRADE, AND RECOMPACT SUBGRADE TO 95%. CONSTRUCT 0.20' HMA (SUPERPAVE) TYPE "A" 3/4" MIX, PG 64-28M OVER 0.25' HMA (SUPERPAVE) TYPE "A" 1" MIX, PG 64-28M OVER 0.50' CLASS II AGGREGATE BASE OVER GEOGRID. ADDITIONAL EXCAVATION MAY BE REQUIRED AS DIRECTED.
 - 7 ADJUST STORM DRAIN MANHOLE TO GRADE BY CONTRACTOR
 - 8 ADJUST SEWER MANHOLE TO GRADE BY WMWD
 - 9 ADJUST WATER VALVE TO GRADE BY CONTRACTOR
 - 10 ADJUST GAS VALVE TO GRADE BY CONTRACTOR
 - 11 RECONSTRUCT TYPE A-6 CONCRETE CURB AND GUTTER PER STD No. 200
 - 12 RECONSTRUCT CONCRETE SIDEWALK PER STD No. 401
 - 13 RECONSTRUCT CONCRETE CURB RAMP PER STD No. 403 CASE "A" AND PER DETAIL SHEET C-1 THROUGH C-5
 - 15 CONSTRUCT TYPE "D" OUTLET PIPE CONNECTION TO DRAINAGE INLET PER CALTRANS STD. P51
 - 16 RECONSTRUCT CONCRETE CROSS-GUTTER AND SPANDREL PER COUNTY STD No. 209

BORDER LAST REVISED 3/30/2021



 <p>PREPARED BY PREPARED UNDER THE SUPERVISION OF: <i>Mike Heath</i> MIKE HEATH ENGINEERING PROJECT MANAGER COUNTY OF RIVERSIDE</p>	<p>LAYOUT LAKEPOINTE DR RECONSTRUCTION PROJECT</p>	<p>SHEET No. L-2 SHEET 04 of 13</p>
	<p>DATE PLOTTED => 1/3/2024 TIME PLOTTED => 8:47:52 AM</p>	<p>DATE 1/03/2024</p>

USERNAME => RAHadeethi
DGN FILE => D2-0049 eaL-02.shd
WO D2-0049
COUNTY FILE No. 973-W

ISSUED BY ADDENDUM No. 2, ATTACHMENT "B"

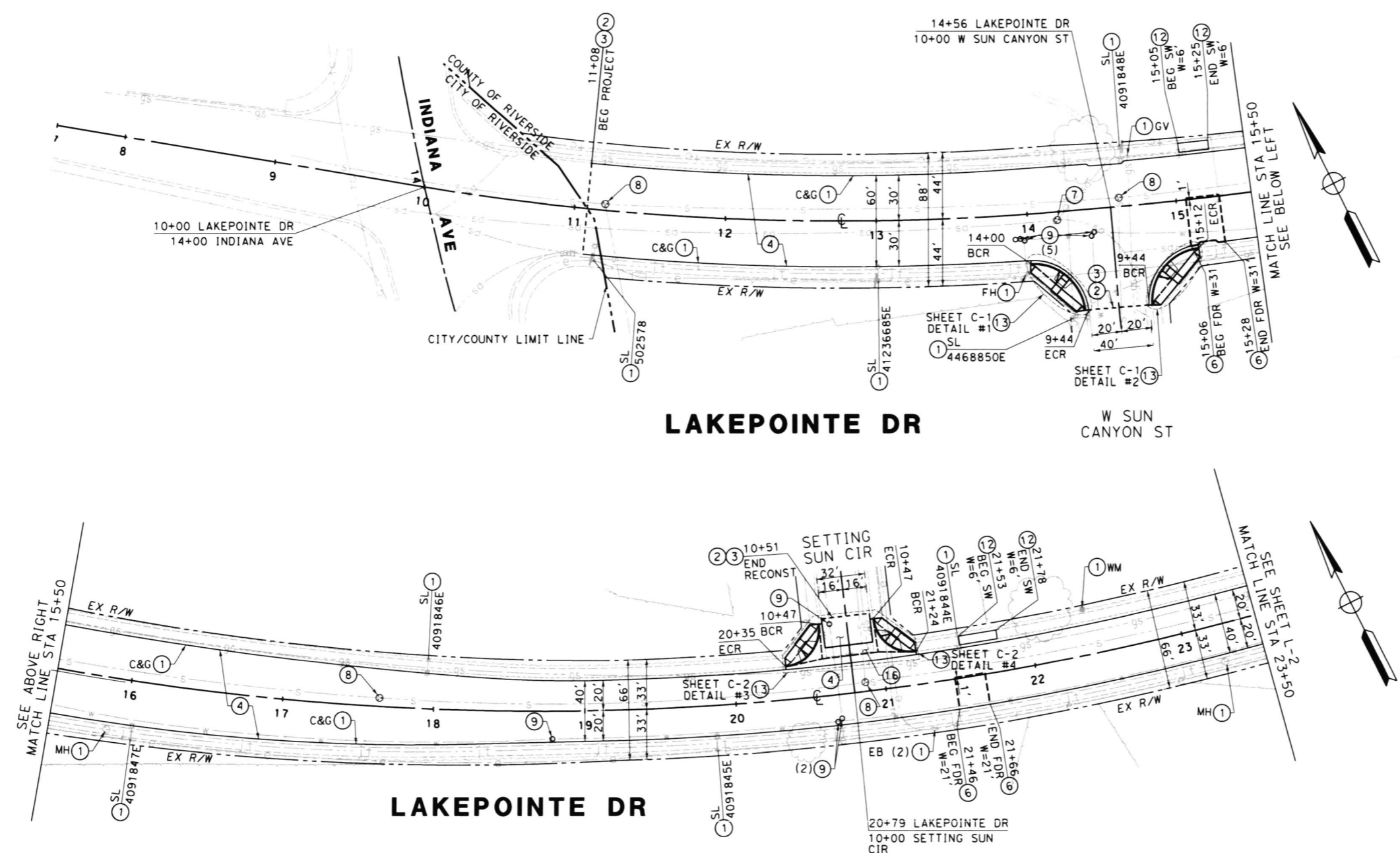

CONSTRUCTION NOTES:

- ① PROTECT IN PLACE
- ② MATCH EXISTING
- ③ SAWCUT
- ④ EXCAVATE EXISTING ASPHALT CONCRETE AND UNDERLYING MATERIAL TO A DEPTH OF 0.45' MOISTURE CONDITION, GRADE, AND RECOMPACT SUBGRADE TO 95%. CONSTRUCT 0.20' HMA (SUPERPAVE) TYPE "A" 3/4" MIX, PG 64-28M OVER 0.25' HMA (SUPERPAVE) TYPE "A" 1" MIX, PG 64-28M
- ⑥ EXCAVATE EXISTING ASPHALT CONCRETE AND UNDERLYING MATERIAL TO A DEPTH OF 0.95' (MIN.), MOISTURE CONDITION, GRADE, AND RECOMPACT SUBGRADE TO 95%. CONSTRUCT 0.20' HMA (SUPERPAVE) TYPE "A" 3/4" MIX, PG 64-28M OVER 0.25' HMA (SUPERPAVE) TYPE "A" 1" MIX, PG 64-28M OVER 0.50' CLASS II AGGREGATE BASE OVER GEOGRID. ADDITIONAL EXCAVATION MAY BE REQUIRED AS DIRECTED.
- ⑦ ADJUST STORM DRAIN MANHOLE TO GRADE BY CONTRACTOR
- ⑧ ADJUST SEWER MANHOLE TO GRADE BY WMWD
- ⑨ ADJUST WATER VALVE TO GRADE BY CONTRACTOR
- ⑫ RECONSTRUCT CONCRETE SIDEWALK PER STD No. 401
- ⑬ RECONSTRUCT CONCRETE CURB RAMP PER STD No. 403 CASE "A" AND PER DETAIL SHEET C-1 THROUGH C-5
- ⑮ RECONSTRUCT CONCRETE CROSS-GUTTER AND SPANDREL PER COUNTY STD No. 209

LAKEPOINTE DR

LAKEPOINTE DR

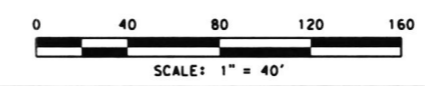

	PREPARED BY	LAYOUT	SHEET No.
	PREPARED UNDER THE SUPERVISION OF: <i>Mike Heath</i> 1/03/2024 MIKE HEATH ENGINEERING PROJECT MANAGER COUNTY OF RIVERSIDE	LAKEPOINTE DR RECONSTRUCTION PROJECT STA 11+08 TO 23+50	L-1 SHEET 03 OF 13

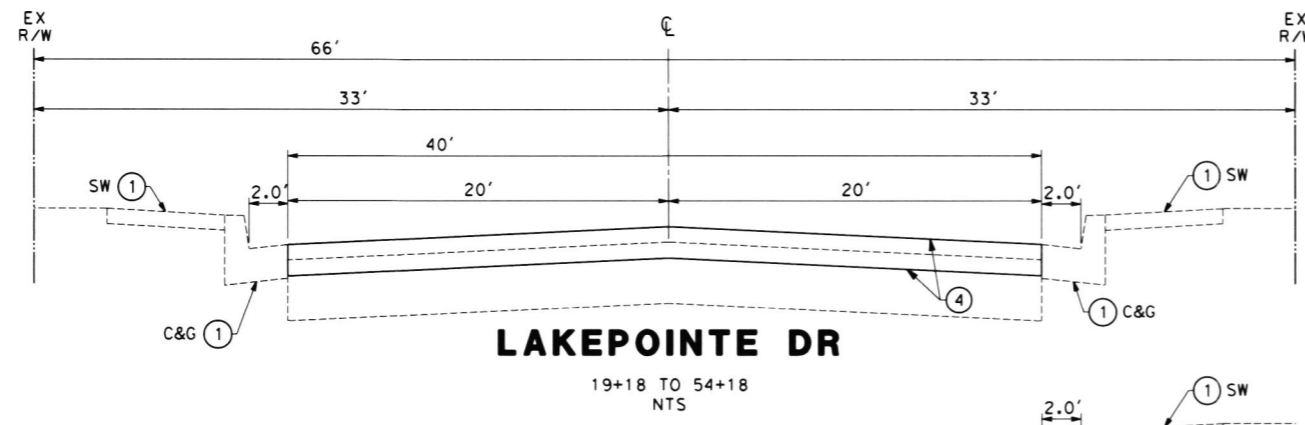

LAKEPOINTE DR

19+18 TO 54+18
NTS

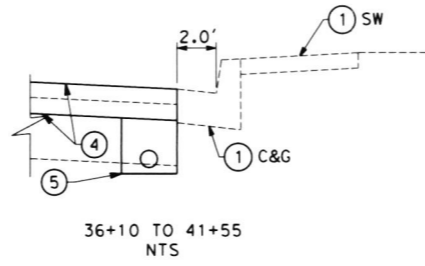

36+10 TO 41+55
NTS

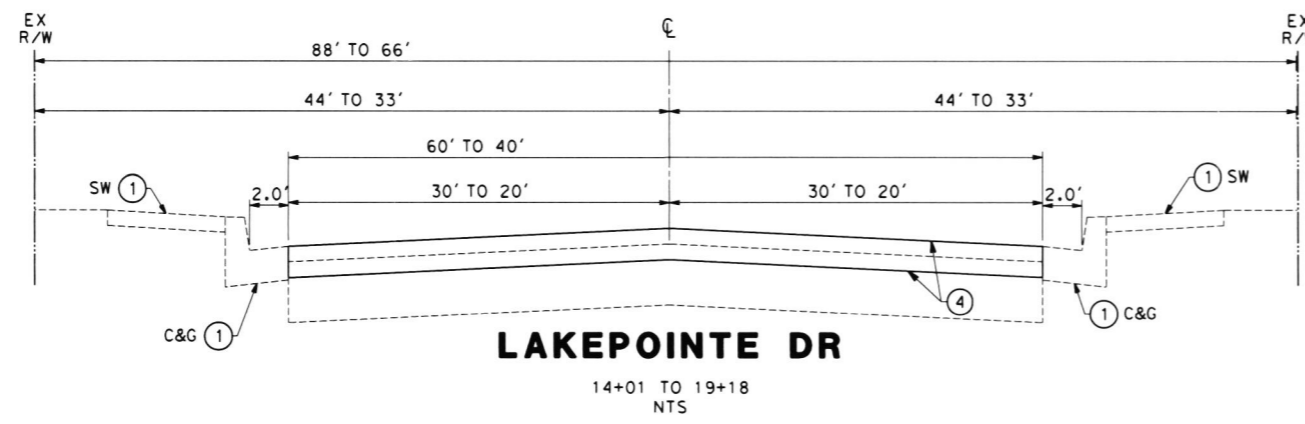

LAKEPOINTE DR

14+01 TO 19+18
NTS

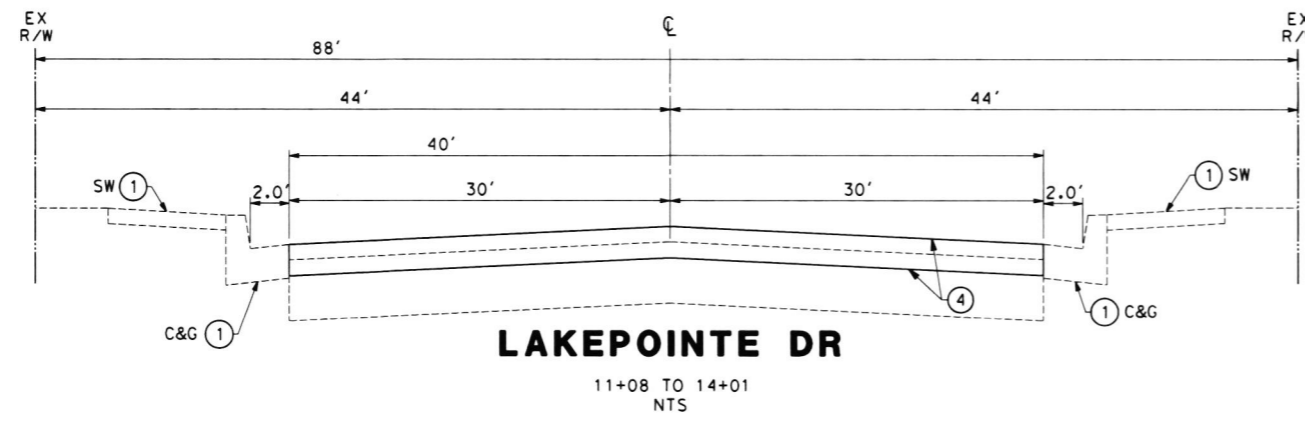

LAKEPOINTE DR

11+08 TO 14+01
NTS

CONSTRUCTION NOTES:

- 1 PROTECT IN PLACE
- 2 MATCH EXISTING
- 3 SAWCUT
- 4 EXCAVATE EXISTING ASPHALT CONCRETE AND UNDERLYING MATERIAL TO A DEPTH OF 0.45' MOISTURE CONDITION, GRADE, AND RECOMPACT SUBGRADE TO 95%. CONSTRUCT 0.20' HMA (SUPERPAVE) TYPE "A" 3/4" MIX, PG 64-28M OVER 0.25' HMA (SUPERPAVE) TYPE "A" 1" MIX, PG 64-28M
- 5 CONSTRUCT SUBSURFACE DRAINAGE SYSTEM PER DETAILS ON SHEET X-1 AND PER CALTRANS STD P51 & P52
- 6 EXCAVATE EXISTING ASPHALT CONCRETE AND UNDERLYING MATERIAL TO A DEPTH OF 0.95' (MIN.) MOISTURE CONDITION, GRADE, AND RECOMPACT SUBGRADE TO 95%. CONSTRUCT 0.20' HMA (SUPERPAVE) TYPE "A" 3/4" MIX, PG 64-28M OVER 0.25' HMA (SUPERPAVE) TYPE "A" 1" MIX PG 64-28M OVER 0.50' CLASS II AGGREGATE BASE OVER GEOGRID. ADDITIONAL EXCAVATION MAY BE REQUIRED AS DIRECTED.
- 7 ADJUST STORM DRAIN MANHOLE TO GRADE BY CONTRACTOR
- 8 ADJUST SEWER MANHOLE TO GRADE BY WWD
- 9 ADJUST WATER VALVE TO GRADE BY CONTRACTOR
- 10 ADJUST GAS VALVE TO GRADE BY CONTRACTOR
- 11 RECONSTRUCT TYPE A-6 CONCRETE CURB AND GUTTER PER STD No. 200
- 12 RECONSTRUCT CONCRETE SIDEWALK PER STD No. 401
- 13 RECONSTRUCT CONCRETE CURB RAMP PER STD No. 403 CASE "A" AND PER DETAIL SHEET C-1 THROUGH C-5
- 14 RECONSTRUCT CONCRETE DRIVEWAY PER STD No. 207. RECONSTRUCT EXISTING ASPHALT CONCRETE, CONCRETE CURB, AND CONCRETE CURB & GUTTER WITHIN R/W AS NEEDED TO MATCH EXISTING PRIVATE ACCESS ROAD TO NEW DRIVEWAY GRADE
- 15 CONSTRUCT TYPE "D" OUTLET PIPE CONNECTION TO DRAINAGE INLET PER CALTRANS STD. P51
- 16 RECONSTRUCT CONCRETE CROSS-GUTTER AND SPANDEL PER COUNTY STD No. 209

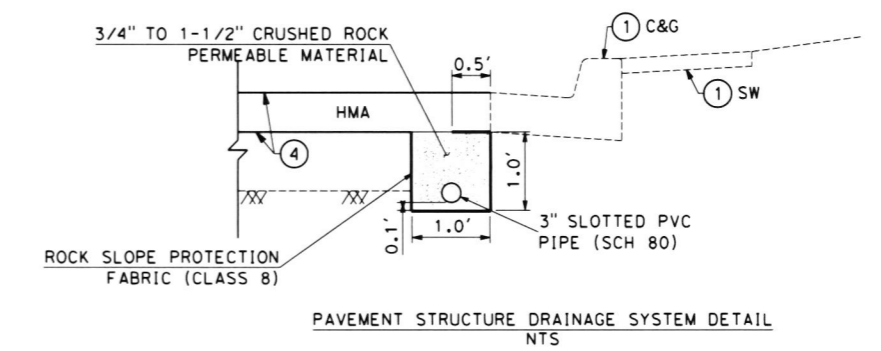

PAVEMENT STRUCTURE DRAINAGE SYSTEM DETAIL
NTS

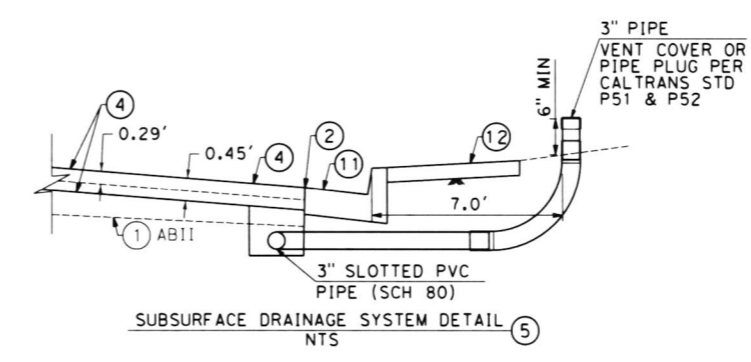

SUBSURFACE DRAINAGE SYSTEM DETAIL
NTS

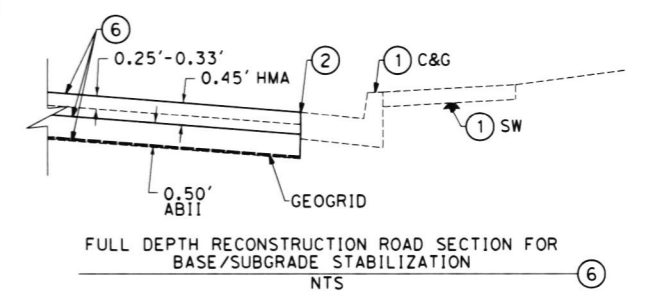

FULL DEPTH RECONSTRUCTION ROAD SECTION FOR
BASE/SUBGRADE STABILIZATION
NTS

<p>PREPARED BY</p> <p>PREPARED UNDER THE SUPERVISION OF:</p> <p><i>Mike Heath</i> 1/03/2024</p> <p>MIKE HEATH ENGINEERING PROJECT MANAGER COUNTY OF RIVERSIDE</p>	<p>TYPICAL CROSS SECTIONS & CONSTRUCTION DETAILS</p> <p>LAKEPOINTE DR RECONSTRUCTION PROJECT</p>	<p>SHEET No.</p> <p>X-1</p> <p>SHEET 02 of 13</p>
		<p>DATE PLOTTED => 1/3/2024 TIME PLOTTED => 8:47:47 AM</p>

**COUNTY OF RIVERSIDE
TRANSPORTATION DEPARTMENT**

BASIS OF BEARING

THE BASIS OF BEARINGS FOR THIS SURVEY IS THE CALIFORNIA STATE PLANE COORDINATE SYSTEM, CCS83, ZONE 6, BASED LOCALLY ON CONTROL STATIONS "CNPP", "MAT2", AND "NOCO GRM" NAD 83(NSRS2007) AS SHOWN HEREON. ALL BEARINGS SHOWN ON THIS MAP ARE GRID, QUOTED BEARINGS AND DISTANCES FROM REFERENCE MAPS OR DEEDS ARE AS SHOWN PER THAT RECORD REFERENCE. ALL DISTANCES SHOWN ARE GROUND DISTANCES UNLESS SPECIFIED OTHERWISE. GRID DISTANCES, MAY BE OBTAINED BY MULTIPLYING THE GROUND DISTANCE BY A COMBINATION FACTOR OF 1.000027271. CALCULATIONS ARE MADE AT THE CENTERLINE INTERSECTION OF MAGNOLIA AVENUE AND BUCHANAN STREET USING THE COORDINATES OF: N: 2,270,03771', E: 6,182,774.55', USING AN ELEVATION OF 690.11'.

BASIS OF ELEVATIONS

THE BASIS OF ELEVATIONS FOR THE SURVEY IS:
BENCHMARK : W 1420
PID: DX 3669
ELEVATION: 681.84' (PER NGS DATA SHEET)
DESCRIPTION: FOUND STAINLESS STEEL ROD IN WELL, 0.75 MILES SOUTHWEST ALONG MAGNOLIA AVENUE FROM THE JUNCTION OF SH 91 IN RIVERSIDE, AT THE CROSSING OF THE ATCHISON TOPEKA AND SANTA FE RAILROAD, 110.9 FEET NORTHEAST OF THE CENTER OF THE CROSSING OF THE RAILROAD & THE CENTERLINE OF THE NORTHEAST BOUND LANES OF THE AVENUE, 32.8 FEET SOUTH OF THE SOUTH RAIL, 3 FEET NORTH EAST OF A TELEPHONE POLE.

**LAKEPOINTE DR
RECONSTRUCTION PROJECT
INDIANA AVE TO S SUN SUMMIT DR
COMMUNITY OF LAKE HILLS
PROJECT No. D2-0049**

ABBREVIATIONS & LEGEND

ABII	AGGREGATE BASE CLASS 2	RECONST	RECONSTRUCTION
BCR	BEGIN CURB RETURN	R/W	RIGHT OF WAY
BEG	BEGIN	SL	STREET LIGHT
C&G	CURB AND GUTTER	ST	STREET
CAB	UTILITY CABINET	STA	STATION
CB	CATCH BASIN	STD	STANDARD
CIR	CIRCLE	SW	SIDEWALK
CL	CENTER LINE	W	WIDTH
CONC	CONCRETE	WM	WATER METER
CT	COURT	WMWD	WESTERN MUNICIPAL WATER DISTRICT
DR	DRIVE	WV	WATER VALVE
DWY	DRIVEWAY	+	FIRE HYDRANT
EB	ELECTRIC BOX	o	GAS METER
ECR	END CURB RETURN	o	GAS VALVE
EX	EXISTING	□	MAIL BOX(S)
FDR	FULL DEPTH RECONSTRUCTION	⊙	MANHOLE
FH	FIRE HYDRANT	⊗	WATER METER
GV	GAS VALVE	o	WATER VALVE
HMA	HOT MIX ASPHALT	⊗	STREET LIGHT
MH	MANHOLE	+	STREET SIGN ATTACHED
MIN	MINIMUM	+	STREET SIGN
NTS	NOT TO SCALE	+	DOUBLE STREET SIGN
PB	PULL BOX		
PED	PEDESTAL		
R	RADIUS		

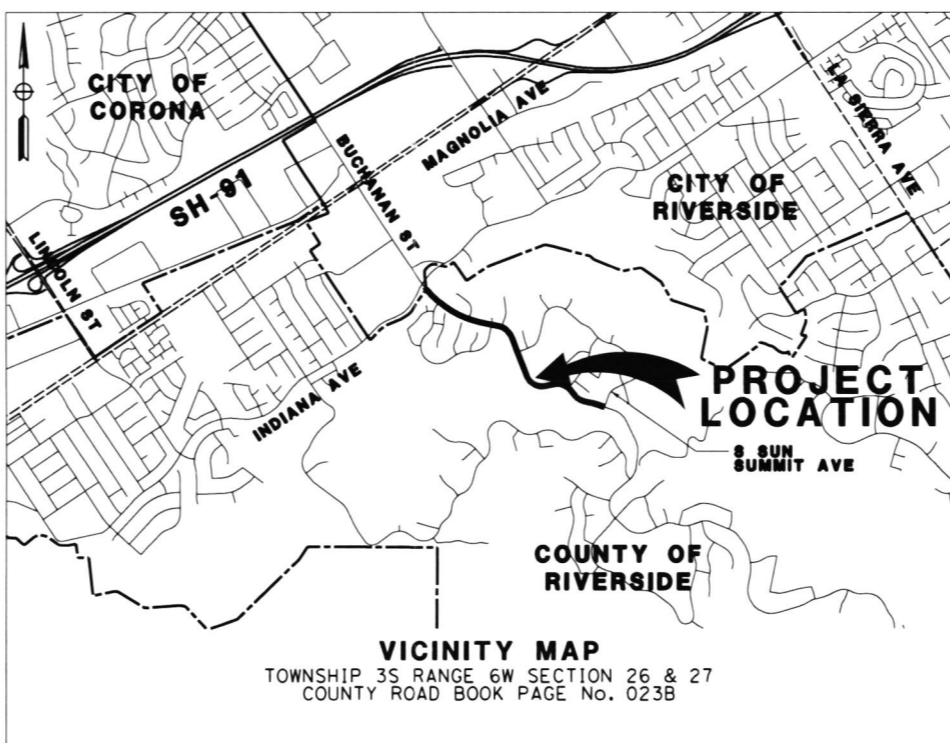
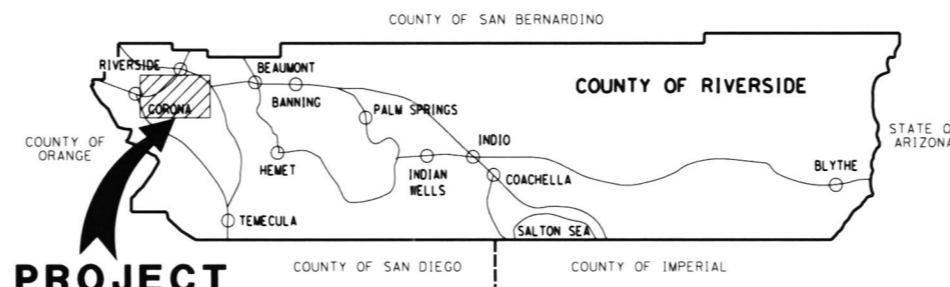

---	CENTER LINE
- - - -	CITY LIMIT LINE
---	EX WALL
- - - -	EX EDGE OF PAVEMENT
- - - - gs	EX GAS LINE
- - - - e	ELECTRICAL UG LINE
- - - - s	EX SEWER LINE
- - - -	EX IRRIGATION SYSTEM
- - - -	RIGHT OF WAY
- - - - sd	EX STORM DRAIN LINE
- - - - w	EX WATER LINE
- - - - j +	EX JOINT UTILITY UG
- - - - tc	EX TELECOMMUNICATION UG

INDEX OF SHEETS

SHEET No.	DESCRIPTION
1	TITLE
2	TYPICAL CROSS SECTIONS & CONSTRUCTION DETAILS
3 - 5	LAYOUT
6 - 10	CONSTRUCTION DETAILS
11 - 13	PAVEMENT DELINEATION & SIGNING

THE CONTRACTOR SHALL NOTIFY UNDERGROUND SERVICE ALERT, BY DIALING 811, AND ALL CONCERNED UTILITY COMPANIES AT LEAST TWO WORKING DAYS IN ADVANCE OF EXCAVATION

BORDER LAST REVISED 3/30/2021

CONCURRED BY PATRICIA ROMO INTERIM DIRECTOR OF TRANSPORTATION COUNTY OF RIVERSIDE 01-03-2023	PREPARED BY MIKE HEATH ENGINEERING PROJECT MANAGER COUNTY OF RIVERSIDE 1/03/2024	TITLE LAKEPOINTE DR RECONSTRUCTION INDIANA AVE TO S SUN SUMMIT DR	SHEET No. T SHEET 01 of 13
---	---	--	--

USERNAME => RAihadeethi
DGN FILE => D2-0049 abT-01.sht

WO D2-0049 COUNTY FILE No. 973-W

D2-0049 LAKEPOINTE DR RECONSTRUCTION PROJECT

ISSUED BY ADDENDUM No. 2, ATTACHMENT "B"

LAST REVISION => 1/3/2024
TIME PLOTTED => 8:47:45 AM

LAKEPOINTE DR

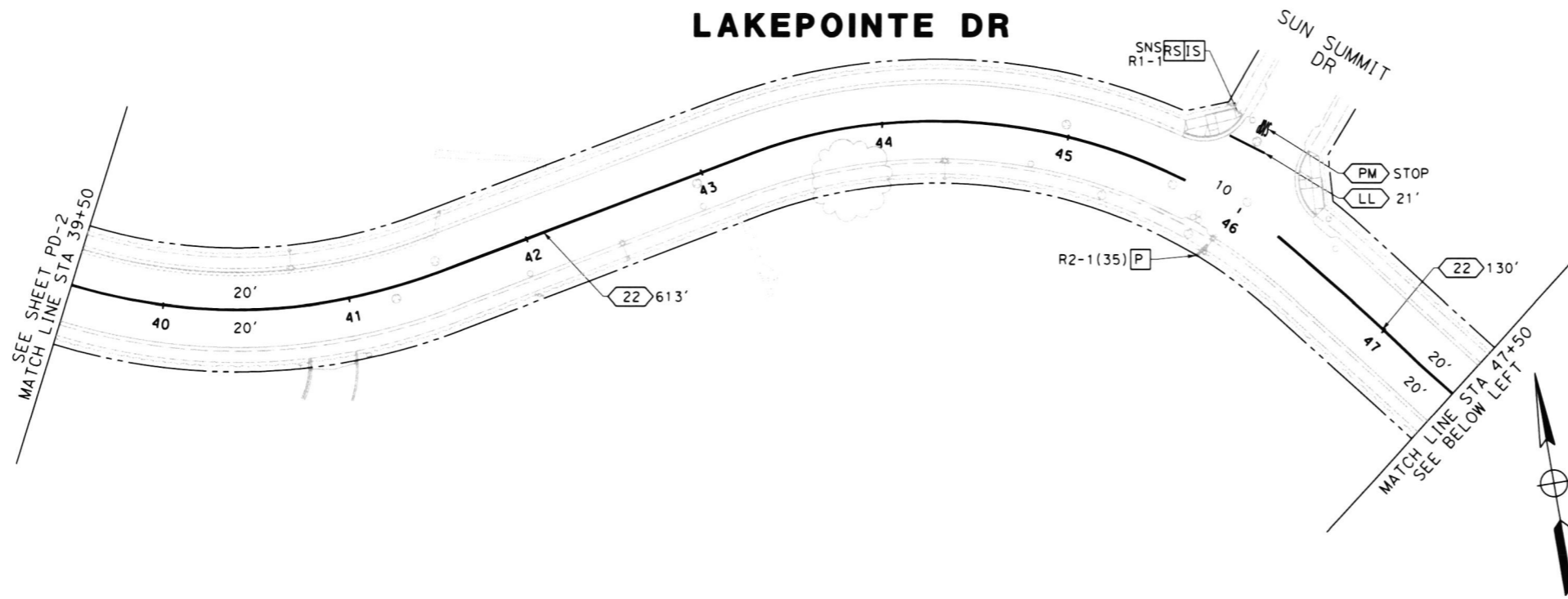

STRIPING NOTES:

- 22 PAINT NO PASSING ZONES-TWO DIRECTION STRIPES AND INSTALL MARKERS PER CALTRANS STD A20A, DETAIL 22
- LL INSTALL THERMOPLASTIC LIMIT LINE PER CALTRANS STD A24D AT LEAST 24" FROM CROSS-GUTTERS
- PM INSTALL THERMOPLASTIC PAVEMENT MARKINGS AS SHOWN PER CALTRANS STD A24A THROUGH A24D FOR ARROWS, SYMBOLS, AND WORDS, WHITE EXCEPT NOTED OTHERWISE

SIGNING NOTES:

- P PROTECT SIGN
- RS REMOVE/SALVAGE SIGN
- IS INSTALL SIGN (STD No. 1220 TO BE USED WHEN INSTALLING SNS)

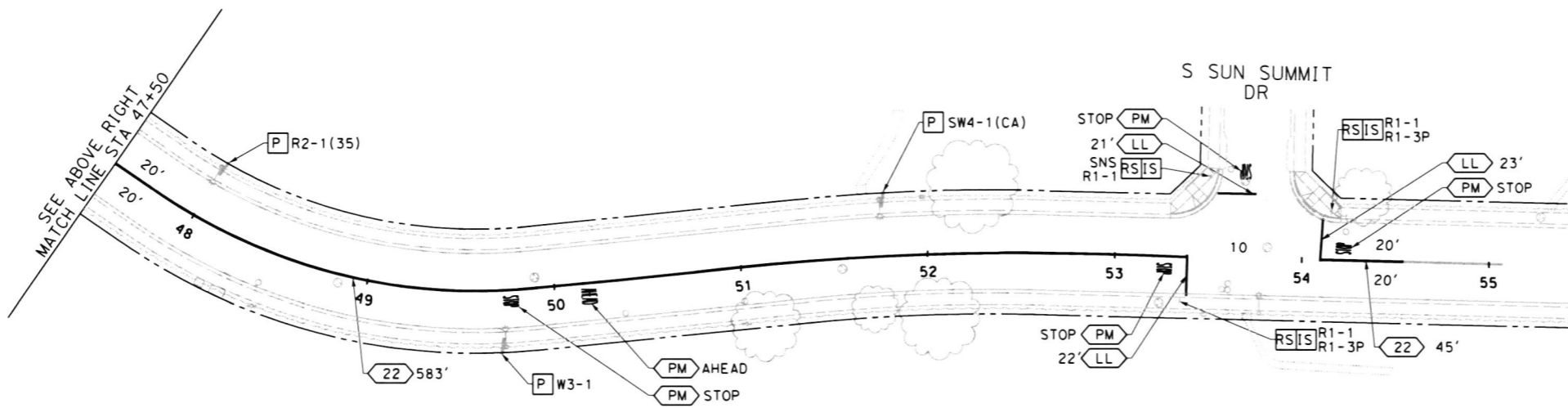

LAKEPOINTE DR

SIGN SIZE	
SNS	VARIES
R1-1	36" x 36"
R1-3P	18" x 6"

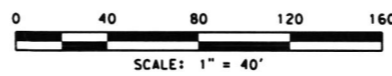

<p>PREPARED BY</p> <p>PREPARED UNDER THE SUPERVISION OF:</p> <div style="display: flex; align-items: center;"> <div> <p>DENNIS ACUNA No. 73955 ENGINEERING DIVISION MANAGER COUNTY OF RIVERSIDE</p> </div> </div> <p style="text-align: right;">01/03/2024 DATE</p>	<p>PAVEMENT DELINEATION & SIGNING SHEET No.</p> <p style="text-align: center;">LAKEPOINTE DR RECONSTRUCTION PROJECT</p> <p style="text-align: center;">STA 11+36 TO 26+00</p>	<p style="font-size: 2em; font-weight: bold;">PD-3</p> <p>SHEET 13 of 13</p>
--	---	--

NOT TO SCALE
 PREPARED UNDER THE SUPERVISION OF:
Mark Lancaster
 DIRECTOR OF TRANSPORTATION
 MARK LANCASTER, P.E.
 11/30/22
 DATE
 REVISION DESCRIPTION
 MARK DATE APPROVED

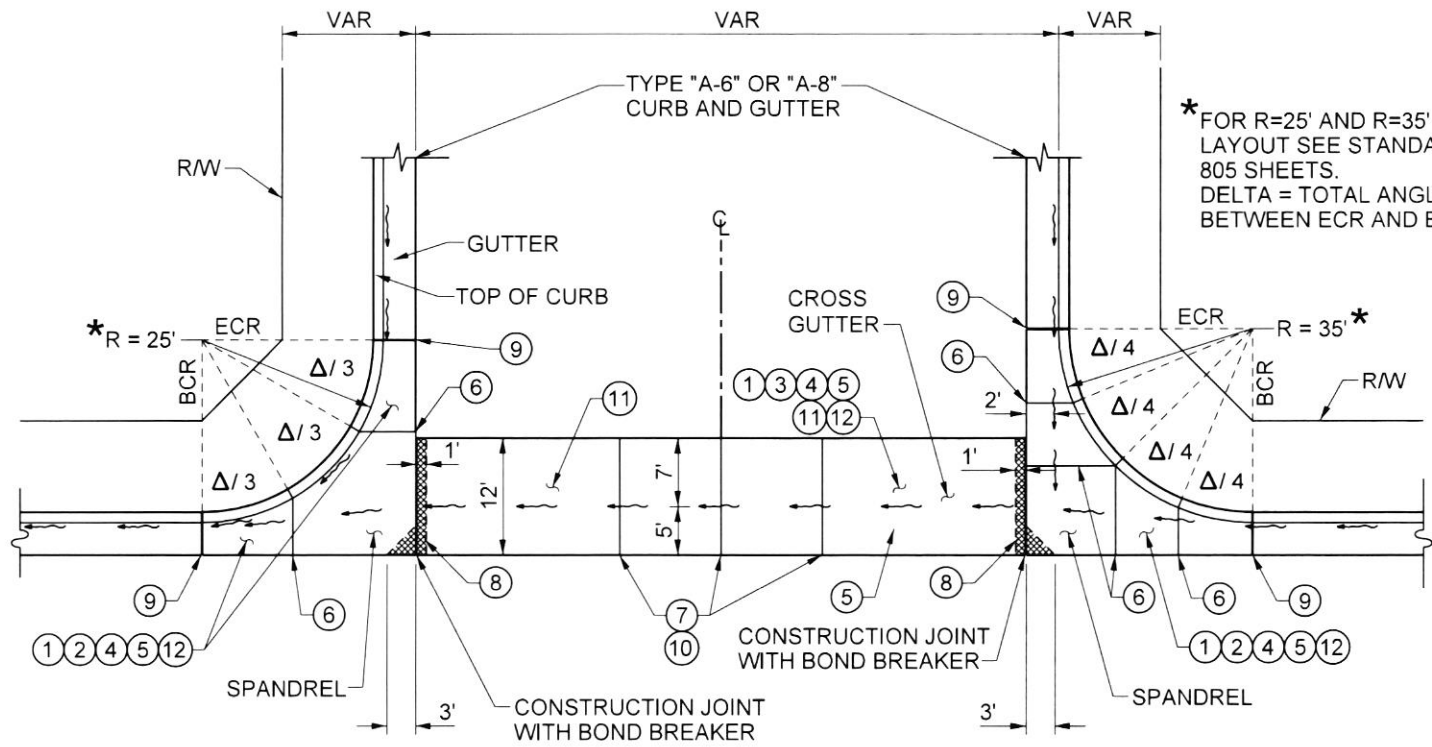

* FOR R=25' AND R=35'
 LAYOUT SEE STANDARD
 805 SHEETS.
 DELTA = TOTAL ANGLE
 BETWEEN ECR AND BCR.



NOTES:

- ① CROSS GUTTER AND SPANDREL FOR USE WITH TYPES "A-6" AND "A-8" CURB.
- ② SPANDREL THICKNESS TO BE 8" MINIMUM.
- ③ CROSS GUTTER THICKNESS TO BE 8" MINIMUM.
- ④ CONCRETE MINIMUM CEMENTITIOUS MATERIAL CONTENT = 590 LB / CU YD.
- ⑤ PLACE MIN 6" AB UNDER ENTIRE SPANDREL AND CROSS GUTTER AREA.
- ⑥ WEAKENED PLANE JOINTS TO BE CONSTRUCTED AT 1/3 POINTS ON 25' RADIUS SPANDRELS, AND AT 1/4 POINTS ON 35' RADIUS SPANDRELS.
- ⑦ CONSTRUCT WEAKENED PLANE JOINT(S) PER STANDARD No. 205 AT MIDPOINT OF CROSS GUTTERS LESS THAN 40' LONG, OR AT 1/3 POINTS OF CROSS GUTTERS OF 40' OR LONGER.
- ⑧ THIS PORTION OF SPANDREL AND CROSS GUTTER SHALL BE CONSTRUCTED WITH 12 INCH THICK, CONCRETE WITH MINIMUM CEMENTITIOUS MATERIAL CONTENT = 590 LB / CU YD. 
- ⑨ CONSTRUCT EXPANSION JOINT PER STANDARD No. 205.
- ⑩ CONSTRUCT WEAKENED PLANE JOINT PER STANDARD No. 205.
- ⑪ CONSTRUCT CROSS GUTTER PER TYPICAL SECTION ON SHEET 2.
- ⑫ WHEN ABUTTING SOIL HAS A HIGH SULFATE CONTENT, SPECIAL CONSIDERATIONS ARE REQUIRED. SEE SPECIFICATIONS SECTION 16.04 OF THIS ORDINANCE.

NOTE:
 FOR PUBLIC WORKS PROJECTS,
 THE SIDEWALK AND CURB FROM BCR
 TO ECR SHALL BE INCLUDED IN THE
 CONTRACT UNIT PRICE FOR "CURB RAMP".

COUNTY OF RIVERSIDE
**CROSS GUTTER
 AND SPANDREL
 (LAYOUT)**
 STANDARD No. 209 (1 OF 2)

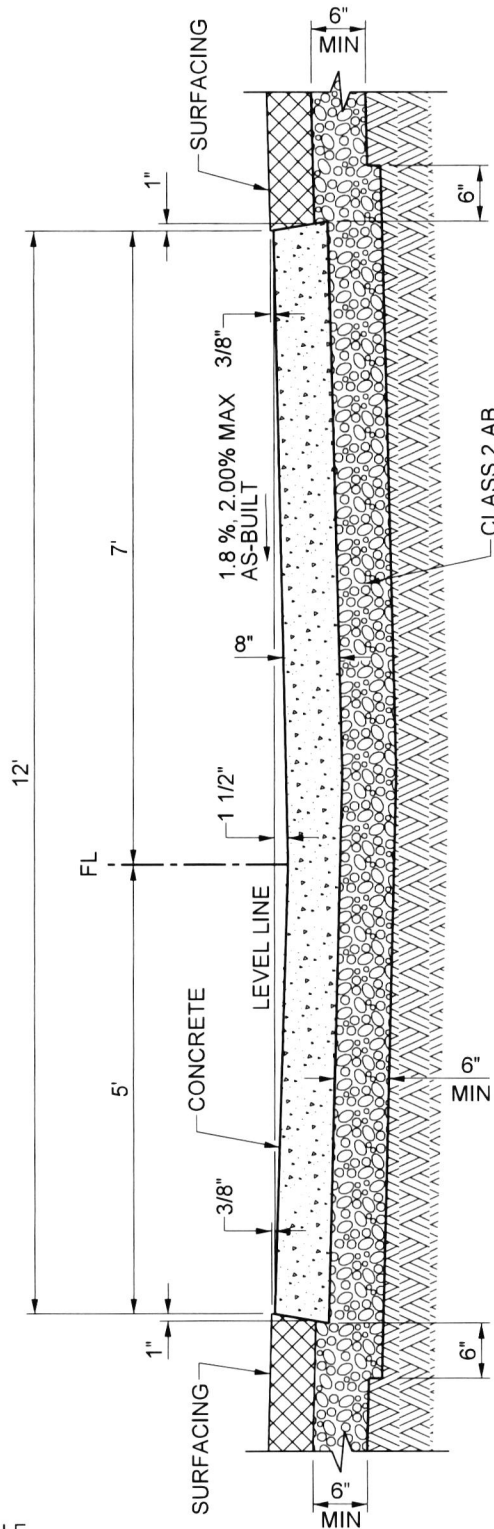

CROSS GUTTER

NOTES:

1. WHEN ABUTTING SOIL HAS A HIGH SULFATE CONTENT, USE A MODIFIED CONCRETE MIX AND PLACE 6" MIN CLASS 2 AGGREGATE BASE AND 6 MIL PLASTIC SHEETING UNDER AND AROUND ALL SIDES OF CONCRETE IMPROVEMENTS. FOR EXPANSIVE SOIL, PLACE 6" MIN CLASS 2 AGGREGATE BASE UNDER CONCRETE IMPROVEMENTS AS DIRECTED BY THE ENGINEER. SEE SPECIFICATIONS SECTIONS 16.03 & 16.04 AND STANDARD No. 401 FOR REFERENCE.
2. RELATIVE COMPACTION OF SUBGRADE UNDER CROSS GUTTER AND SPANDREL SHALL BE 95% MINIMUM.
3. FOR PUBLIC WORKS PROJECTS, THE AB AND ALL REQUIRED MATERIAL SHALL BE INCLUDED IN THE CONTRACT UNIT PRICE.
4. CONCRETE FOR CROSS GUTTER AND SPANDREL SHALL HAVE MINIMUM CEMENTITIOUS MATERIAL CONTENT = 590 LB / CU YD.

NOT TO SCALE

PREPARED UNDER THE SUPERVISION OF:

Mark Lancaster

DIRECTOR OF TRANSPORTATION
MARK LANCASTER, P.E.

11/30/22
DATE

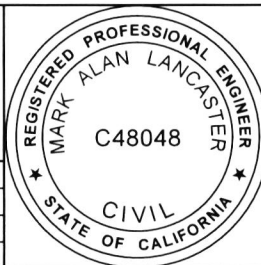

COUNTY OF RIVERSIDE

**CROSS GUTTER
AND SPANDREL
(TYPICAL SECTION)**

STANDARD No. 209 (2 OF 2)

REVISION	DESCRIPTION	MARK	DATE	APPROVED

Bid

Date: 12-15-23

To: County of Riverside, hereafter called "County";

Bidder: All American Asphalt
(hereafter called "Contractor")

The undersigned, Contractor, having carefully examined the site and the Contract Documents for the construction of **Lakepointe Drive Reconstruction, Indiana Avenue to Southern Sun Summit Drive, Community of Lake Hills, Project No. D2-0049** hereby proposes to construct the work in accordance with the Contract Documents, including **Addenda Number(s)** _____ (Fill in addenda numbers if addenda have been issued.) for the amount stated in this Bid.

By submitting this Bid, Contractor agrees with County:

1. That unless withdrawn in person by Contractor or some person authorized in writing by Contractor (not by telephone or facsimile) before the time specified in the Notice Inviting Bids for the public opening of bids, this Bid constitutes an irrevocable offer for 90 calendar days after that date.
2. County has the right to reject any or all Bids and to waive any irregularities or informalities contained in a Bid.
3. To execute the Contract and deliver the Performance Bond, Payment Bond and Insurance Certificate with endorsements, that comply with the requirements set forth in the Instruction to Bidders and General Conditions, within ten (10) business days of the date of the Notice of Acceptance of Bid and Intent to Award as issued by the County.
4. That the contract shall be awarded upon a resolution or minute order to that effect duly adopted by the governing body of County; and that execution of the Contract shall constitute a written memorial thereof.
5. To submit to the County such information as County may require determining whether a particular Bid is the lowest responsible bid submitted.
6. That the accompanying Bid Bond, certified check or cashier's check is in an amount not less than 10% of the total bid submitted and constitutes a guarantee that if awarded the contract, Contractor will execute the Contract and deliver the required bonds within ten (10) business days after notice of award. If Contractor fails to execute and deliver said documents, the bond or check is to be charged with the costs of the resultant damages to the County, including but not limited to: publication costs, the difference in money between the amount bid and the amount in excess of the bid which it costs County to do or cause to be done for the work involved, lease and rental costs, additional salaries and overhead, increased interest and costs of funding the project, attorney expense, additional engineering and architectural expense and cost of maintaining or constructing alternate facilities occasioned by the failure to execute and deliver said documents.
7. By signing this Bid the Contractor certifies that the representations made therein are made under penalty of perjury.

Lakepointe Drive Reconstruction
Indiana Avenue to Southern Sun Summit Drive
Community of Lake Hills
Project No. D2-0049

REVISED PROPOSAL

ITEM No.	ITEM CODE	ITEM	UNIT	ESTIMATED QUANTITY	ITEM PRICE (IN FIGURES)	TOTAL (IN FIGURES)
----------	-----------	------	------	--------------------	-------------------------	--------------------

BASE BID SCHEDULE - Lakepointe Drive Reconstruction

1	066100	DUST ABATEMENT	LS	1	5,000	5,000
2	100100	DEVELOP WATER SUPPLY	LS	1	3,000 5 (E)	3,000
3	120100	TRAFFIC CONTROL SYSTEM	LS	1	220,000	220,000
4	130200	PREPARE WATER POLLUTION CONTROL PROGRAM	LS	1	8,880.85	8,880.85
5	170103	CLEARING AND GRUBBING	LS	1	15,000	15,000
6	190101(F)	ROADWAY EXCAVATION	CY	3,891	70	272,370
7	260203	CLASS 2 AGGREGATE BASE	CY	390	54	21,060
8	198215	SUBGRADE ENHANCEMENT GEOGRID	SQYD	2,330	4	9,320
9	729011	ROCK SLOPE PROTECTION FABRIC (CLASS 8)	SQYD	468	2	936
10	680287	3" SLOTTED PLASTIC PIPE UNDERDRAIN [SCH 80]	LF	545	76	41,420
11	681107	3" PLASTIC PIPE (EDGE DRAIN OUTLET) [SCH 80]	LF	40	300	12,000
12	710212	ADJUST MANHOLE TO GRADE [STORM DRAIN]	EA	12	1,400	16,800
13	720110	SMALL-ROCK SLOPE PROTECTION [PERMEABLE MATERIAL - CRUSHED ROCK]	CY	23	140	3,220
14	390132	HOT MIX ASPHALT (TYPE A)	TON	7,647	102	779,994
15	731521	MINOR CONCRETE (SIDEWALK)	SQFT	874	14	12,236
15.A	017315	MINOR CONCRETE (CURB RAMP) (CRS 403 - CASE A)	EA	16	8,800	140,800
15.B	017317	MINOR CONCRETE (CROSS-GUTTER AND SPANDREL)	SQFT	2,980	26	77,480
16	017304	MINOR CONCRETE (CURB AND GUTTER) (CRS 200)	LF	30	80	2,400
17	017310	MINOR CONCRETE (DRIVEWAY APPROACH) (CRS 207)	SQFT	400	20	8,000

ITEM No.	ITEM CODE	ITEM	UNIT	ESTIMATED QUANTITY	ITEM PRICE (IN FIGURES)	TOTAL (IN FIGURES)
BASE BID SCHEDULE - Lakepointe Drive Reconstruction (Continued)						
18	000001	ITEM DELETED PER ADDENDUM No. 2	----	-----	-----	-----
19	820410	SALVAGE ROADSIDE SIGN	EA	16	100	1,600
20	820840	ROADSIDE SIGN - ONE POST	EA	20	375	7,500
21	810230(F)	PAVEMENT MARKER (RETROREFLECTIVE)	EA	370	8.50	3,145
22	840519	THERMOPLASTIC CROSSWALK AND PAVEMENT MARKING	SQFT	905	5.75	5,203.75
23	840656(F)	PAINT TRAFFIC STRIPE (2-COAT)	LF	4,620	.75	3,465
24	010602	MISCELLANEOUS WORK (AS DIRECTED)	FA	1	85,000.00	85,000.00

BASE BID SCH.
TOTAL: One million seven hundred fifty-five thousand three hundred thirty dollars sixty cents \$1,755,330.60
ITEMS 1-24 "WORDS"

ALTERNATIVE BID SCHEDULE 1 - Western Municipal Water District (WMWD) Facility Adjustments

25	710228	ADJUST SEWER MANHOLE	EA	16	347	5,552
----	--------	----------------------	----	----	-----	-------

ALT. BID SCH. 1
TOTAL: Five thousand five hundred fifty-two dollars \$5,552
ITEM 25 "WORDS"

**BASE BID SCH. + ALT. BID SCH. 1
PROJECT**

TOTAL: One million seven hundred sixty-one thousand three hundred eighty-two dollars sixty cents \$1,761,382.60
ITEMS 1 - 25 "WORDS"

Bidder Data and Signature

Name of Bidder: All American Asphalt

Type of organization: Corporation

Person(s) authorized to sign for Bidder: Edward J Carlson, Vice President

Michael Farkas, Secretary

Mark Luer, President

Note:

If Bidder is a **Corporation**, state legal name of Corporation and also names of the president, vice-president, secretary, treasurer and manager thereof.

If Bidder is a **Co-Partnership**, state true name of firm and also names of all individual co-partners composing firm.

If Bidder is a sole proprietorship or an **Individual**, state first and last name(s) in full.

If Bid is signed by an agent other than an owner, partner or corporate officer, Bid shall be accompanied by a power-of-attorney.

Business Street Address: 400 East Sixth St Corona, CA 92879
(Please include business address even if P.O. Box is used.)

Business City, State, Zip Code: Corona, CA 92879

P.O. Box- Number: PO BOX 2229 CORONA, CA 92879

P.O. Box- City, State, Zip Code: Corona, CA 92879

Phone: (951-736-7600)

Facsimile: (951-736-7646)

E-mail: publicworks@allamericanasphalt.com

Contractor's license number: 267073

License Classification(s): A, C-12

Expiration date: 1/31/2024

Department of Industrial Relations Registration Number: 1000001051

Bidder Data and Signature (continued)

Accompanying this Bid is a certified check, cashier check or bid bond in an amount equal to at least ten (10) percent of the total bid for:

**Lakepointe Drive Reconstruction
Indiana Avenue to Southern Sun Summit Drive
Community of Lake Hills
Project No. D2-0049**

By my signature on this Bid, I certify, under penalty of perjury under the laws of the State of California, that all the information on this form is true and correct.

IN WITNESS WHERE OF Bidder/Contractor executed this Bid as of the date set forth on page **B1** of this Bid.

Signature:



Name (printed):

Edward J Carlson

Title:

Vice President
"Contractor"

Subcontractor List

Bidder/Contractor submits the following complete list of each Subcontractor who will perform work, labor or render service in or about the construction in an amount in excess of 1/2 of 1% of the total bid or \$10,000 whichever is greater.

Check box on right side of row if any construction item, for the listed Subcontractor, is partial work. If partial work is to be performed within a certain construction item or trade, the Bidder/Contractor shall specify the portion(s) of the work to be performed by the different subcontractors or Bidder/Contractor will be subject to provisions of Public Contract Code Section 4106.

Name of Bidder (Prime/General Contractor): All American Asphalt

	Subcontractor Name	License Number	DIR Registration Number	Business Address (City, State)	Construction Item(s) [Item Number and Description]	Check if Partial Work
1.	Contracting	991122	1000011750	Riverside CA	19-23 sign	<input type="checkbox"/>
2.						<input type="checkbox"/>
3.						<input type="checkbox"/>
4.						<input type="checkbox"/>
5.						<input type="checkbox"/>
6.						<input type="checkbox"/>

Additional Subcontractor List(s) may be attached to the Bid.
(A copy of this form may be attached with additional Subcontractor information.)

Percent of work to be performed by Subcontractors: 1.19 %

Note: A minimum of 50% of the work is required to be performed by the prime/general Contractor.

Subcontractor List

Bidder/Contractor submits the following complete list of each Subcontractor who will perform work, labor or render service in or about the construction in an amount in excess of 1/2 of 1% of the total bid or \$10,000 whichever is greater.

Check box on right side of row if any construction item, for the listed Subcontractor, is partial work. If partial work is to be performed within a certain construction item or trade, the Bidder/Contractor shall specify the portion(s) of the work to be performed by the different subcontractors or Bidder/Contractor will be subject to provisions of Public Contract Code Section 4106.

Name of Bidder (Prime/General Contractor): All American Asphalt

	Subcontractor Name	License Number	DIR Registration Number	Business Address (City, State)	Construction Item(s) [Item Number and Description]	Check if Partial Work
1.						<input type="checkbox"/>
2.						<input type="checkbox"/>
3.						<input type="checkbox"/>
4.						<input type="checkbox"/>
5.						<input type="checkbox"/>
6.						<input type="checkbox"/>

Additional Subcontractor List(s) may be attached to the Bid.
(A copy of this form may be attached with additional Subcontractor information.)

Percent of work to be performed by Subcontractors: _____%

Note: A minimum of 50% of the work is required to be performed by the prime/general Contractor.

Non-Collusion Declaration

To be executed by bidder and submitted with bid.
(Title 23 United States Code Section 112 and Public Contract Code Section 7106)

The undersigned declares:

I am the Vice President (Title) of All American Asphalt (Company),
the party making the foregoing bid.

The bid is not made in the interest of, or on behalf of, any undisclosed person, partnership, company, association, organization, or corporation. The bid is genuine and not collusive or sham. The bidder has not directly or indirectly induced or solicited any other bidder to put in a false or sham bid. The bidder has not directly or indirectly colluded, conspired, connived, or agreed with any bidder or anyone else to put in a sham bid, or that anyone shall refrain from bidding. The bidder has not in any manner, directly or indirectly, sought by agreement, communication, or conference with anyone to fix the bid price of the bidder or any other bidder, or to fix any overhead, profit, or cost element of the bid price, or of that of any other bidder.

All statements contained in the bid are true. The bidder has not, directly or indirectly, submitted his or her bid price of any breakdown thereof, or the contents thereof, or divulged information or data relative thereto, to any corporation, partnership, company, association, organization, bid depository, or to any member or agent thereof to effectuate a collusive or sham bid, and has not paid, and will not pay, any person or entity for such purpose.

Any person executing this declaration on behalf of a bidder that is a corporation, partnership, joint venture, limited liability company, limited liability partnership, or any other entity, hereby represents that he or she has full power to execute, and does execute, this declaration on behalf of the bidder.

I declare under penalty of perjury under the applicable laws that the foregoing is true and correct and that this declaration is executed on

December (Month) 15th (Day) of 2023 (Year),

at Corona (City), California (State).

Signature of Declarant: _____

Printed name of Declarant: _____

Edward J Carlson

Name of Bidder (Company): _____

All American Asphalt

Title or Office: _____

Vice President

Note: Notarization of signature required.

Check box if attachment is included.



CALIFORNIA ALL-PURPOSE ACKNOWLEDGEMENT

CIVIL CODE § 1189

A notary public or other officer completing this certificate verifies only the identity of the individual who signed the document to which this certificate is attached, and not the truthfulness, accuracy, or validity of that document.

State of California

County of Riverside

On December 15, 2023 before me, Sarah Amanda Langley, Notary Public
Date Here insert name and Title of the Officer

personally appeared Edward J. Carlson
Name(s) of Signer(s)



who proved to me on the basis of satisfactory evidence to be the person(s) whose name(s) is/are subscribed to the within instrument and acknowledged to me that he/she/they executed the same in his/her/their authorized capacity(ies), and that by his/her/their signature(s) on the instrument the person(s), or the entity upon behalf of which the person(s) acted, executed the instrument.

I certify under PENALTY OF PERJURY under the laws of the State of California that the forgoing paragraph is true and correct.

WITNESS my hand and official seal.

Signature Sarah Amanda Langley
Signature of Notary Public

Place Notary Seal Above

OPTIONAL

Though the information below is not required by law, it may prove valuable to person relying on the document and could prevent fraudulent removal and reattachment of this form to another document.

Description of Attached Document

Title or Type of Document Non Collusion Declaration

Document Date: 12/15/2023 Number of Pages: 1

Signer(s) Other Than Named Above: _____

Capacity(ies) Claimed by Signer(s)

Signer's Name: Edward J. Carlson

- Individual
- Corporate Officer — Title(s): Vice President
- Partner Limited General
- Attorney in Fact
- Trustee
- Other: _____



Signer is Representing:
All American Asphalt

Signer's Name: N/A

- Individual
- Corporate Officer — Title(s): N/A
- Partner Limited General
- Attorney in Fact
- Trustee
- Other: N/A

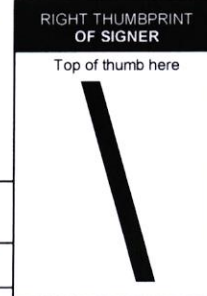

Signer is Representing:
N/A

Iran Contracting Act
(Public Contract Code sections 2200-2208)

Prior to bidding on, submitting a proposal or executing a contract or renewal for a County of Riverside contract for goods or services of **\$1,000,000 or more**, a Contractor must either:

- a) Certify it is not on the current list of persons engaged in investment activities in Iran created by the California Department of General Services (“DGS”) pursuant to Public Contract Code section 2203(b) and is not a financial institution extending twenty million dollars (\$20,000,000) or more in credit to another person, for 45 days or more, if that other person will use the credit to provide goods or services in the energy sector in Iran and is identified on the current list of persons engaged in investment activities in Iran created by DGS; or
- b) Demonstrate it has been exempted from the certification requirement for that solicitation or contract pursuant to Public Contract Code section 2203(c) or (d).

To comply with this requirement, please insert your Contractor or financial institution name and Federal ID Number (if available) and complete one of the options below. Please note: California law establishes penalties for providing false certifications, including civil penalties equal to the greater of \$250,000 or twice the amount of the contract for which the false certification was made; contract termination; and three-year ineligibility to bid on contracts. (Public Contract Code section 2205.)

Option #1 – Certification

I, the official named below, certify I am duly authorized to execute this certification on behalf of the vendor/financial institution identified below, and the vendor/financial institution identified below is **not** on the current list of persons engaged in investment activities in Iran created by DGS and is not a financial institution extending twenty million dollars (\$20,000,000) or more in credit to another person/vendor, for 45 days or more, if that other person/vendor will use the credit to provide goods or services in the energy sector in Iran and is identified on the current list of persons engaged in investment activities in Iran created by DGS.

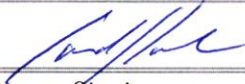
<i>Contractor Name/Financial Institution (Printed)</i> All American Asphalt		<i>Federal ID Number (or n/a)</i> 95-2595043
<i>By (Authorized Signature)</i> 		
<i>Printed Name and Title of Person Signing</i> Edward J Carlson, Vice President		
<i>Date Executed</i> 12/15/2023	<i>Executed in</i> Corona, CA	

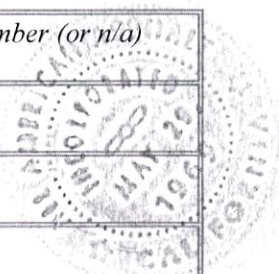

Option #2 – Exemption

Pursuant to Public Contract Code sections 2203(c) and (d), a public entity may permit a Contractor/financial institution engaged in investment activities in Iran, on a case-by-case basis, to be eligible for, or to bid on, submit a proposal for, or enters into or renews, a contract for goods and services.

If you have obtained an exemption from the certification requirement under the Iran Contracting Act, please fill out the information below, and **attach documentation demonstrating the exemption approval.**

<i>Contractor Name/Financial Institution (Printed)</i>		<i>Federal ID Number (or n/a)</i>
<i>By (Authorized Signature)</i>		
<i>Printed Name and Title of Person Signing</i>		
<i>Date Executed</i>	<i>Executed in</i>	

Opt Out of Payment Adjustments for Price Index Fluctuations

Lakepointe Drive Reconstruction
Indiana Avenue to Southern Sun Summit Drive
Community of Lake Hills
Project No. D2-0049

To opt out of the payment adjustments for price index fluctuations, as specified in Standard Specifications Section 9-1.07 "Payment Adjustments for Price Index Fluctuations," completely fill in, date, sign, and submit this form with the Bid documents.

By signing and submitting this form, our company hereby opts out of the payment adjustments for price index fluctuations for the above-named project.

Date: 12-15-23

Company Name (Bidder): All American Asphalt

Signature: 

(Signature of Company's authorized officer or designated representative)

Name (printed): Edward J Carlson

Title: Vice President

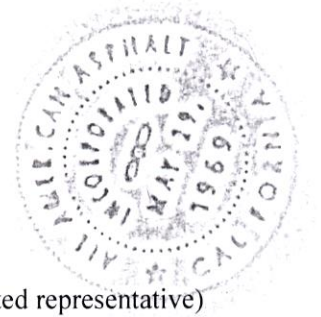

Bid Bond

Recitals:

1. All American Asphalt "Contractor", has submitted his/her Contractor's Proposal to County of Riverside, "County", for the construction of public work for Lakepointe Drive Reconstruction, Indiana Avenue to Southern Sun Summit Drive, Community of Lake Hills, Project No. D2-0049 in accordance with a Notice Inviting Bids from the County.
2. Fidelity and Deposit Company of Maryland a Illinois corporation, hereafter called "Surety", is the surety of this bond.

Agreement:

We, Contractor as Principal and Surety as Surety, jointly and severally agree and state as follows:

1. The amount of the obligation of this bond is 10% of the amount of the Contractor's Proposal, including bid alternates, and inures to the benefit of County.
2. This Bond is exonerated by (1) County rejecting said Proposal or, in the alternate, (2) if said Proposal is accepted, Contractor executes the Contract and furnishes the Bonds as agreed to in its Proposal, otherwise it remains in full force and effect for the recovery of loss, damage and expense of County resulting from failure of Contractor to act as agreed to in its Proposal. Some types of possible loss, damage and expense are specified in the Contractor's Proposal.
3. Surety, for value received, stipulates and agrees that its obligations hereunder shall in no way be impaired or affected by any extension of time within which County may accept the Proposal and waives notice of any such extension.
4. This Bond is binding on our heirs, executors, administrators, successors and assigns.

Dated: December 6, 2023

Signatures:

Fidelity and Deposit Company of Maryland

All American Asphalt

By: Rebecca Haas-Bates
Rebecca Haas-Bates

By: [Signature]

Title: Attorney in Fact
"Surety"

Title: Edward J Carlson, Vice President
"Contractor"

STATE OF **Please See Attached**
COUNTY _____ }
OF _____

ss. SURETY'S ACKNOWLEDGEMENT

On _____ before me, _____ personally appeared, _____ known to me, or proved to me on the basis of satisfactory evidence, to be the person whose name is subscribed to the within instrument and acknowledged to me that he/she executed the same in his/her authorized capacities, and that by his/her signature on the instrument the person, or the entity upon behalf of which the person acted, executed the instrument.

WITNESS my hand and official seal.

Signature of Notary Public

Notary Public (Seal)

Note: This Bond must be executed by both Contractor and Surety with corporate seal affixed. All signatures must be notarized. (Attach acknowledgements).

CALIFORNIA ALL-PURPOSE ACKNOWLEDGMENT

CIVIL CODE § 1189

A notary public or other officer completing this certificate verifies only the identity of the individual who signed the document to which this certificate is attached, and not the truthfulness, accuracy, or validity of that document.

State of California)
County of Orange)

On 12/06/2023 before me, Alma Karen Hernandez, Notary Public
Date Here Insert Name and Title of the Officer

personally appeared Rebecca Haas-Bates
Name(s) of Signer(s)

who proved to me on the basis of satisfactory evidence to be the person(s) whose name(s) is/are subscribed to the within instrument and acknowledged to me that he/she/they executed the same in his/her/their authorized capacity(ies), and that by his/her/their signature(s) on the instrument the person(s), or the entity upon behalf of which the person(s) acted, executed the instrument.

I certify under PENALTY OF PERJURY under the laws of the State of California that the foregoing paragraph is true and correct.

WITNESS my hand and official seal.



Signature [Handwritten Signature]
Signature of Notary Public

Place Notary Seal Above

OPTIONAL

Though this section is optional, completing this information can deter alteration of the document or fraudulent reattachment of this form to an unintended document.

Description of Attached Document

Title or Type of Document: Bid Bond Document Date: 12/06/2023
Number of Pages: One(1) Signer(s) Other Than Named Above: All American Asphalt

Capacity(ies) Claimed by Signer(s)

Signer's Name: Rebecca Haas-Bates
 Corporate Officer — Title(s): _____
 Partner — Limited General
 Individual Attorney in Fact
 Trustee Guardian or Conservator
 Other: _____

Signer's Name: _____
 Corporate Officer — Title(s): _____
 Partner — Limited General
 Individual Attorney in Fact
 Trustee Guardian or Conservator
 Other: _____

Signer Is Representing: _____
Fidelity and Deposit Company of Maryland

Signer Is Representing: _____

CALIFORNIA ALL-PURPOSE ACKNOWLEDGEMENT

CIVIL CODE § 1189

A notary public or other officer completing this certificate verifies only the identity of the individual who signed the document to which this certificate is attached, and not the truthfulness, accuracy, or validity of that document.

State of California

County of Riverside

On December 15, 2023 before me, Sarah Amanda Langley, Notary Public
Date Here Insert name and Title of the Officer

personally appeared Edward J. Carlson
Name of Signer



who proved to me on the basis of satisfactory evidence to be the person(s) whose name(s) is/are subscribed to the within instrument and acknowledged to me that he/she/they executed the same in his/her/their authorized capacity(ies), and that by his/her/their signature(s) on the instrument the person(s), or the entity upon behalf of which the person(s) acted, executed the instrument.

I certify under PENALTY OF PERJURY under the laws of the State of California that the forgoing paragraph is true and correct.

WITNESS my hand and official seal.

Signature Sarah Amanda Langley
Signature of Notary Public

Place Notary Seal Above

OPTIONAL

Though the information below is not required by law, it may prove valuable to person relying on the document and could prevent fraudulent removal and reattachment of this form to another document.

Description of Attached Document

Title or Type of Document Bid Bond

Document Date: 12/06/2023 Number of Pages: 3

Signer(s) Other Than Named Above: Rebecca Haas-Bates, Attorney in Fact

Capacity(ies) Claimed by Signer(s)

Signer's Name: Edward J. Carlson

- Individual
- Corporate Officer -- Title(s): Vice President
- Partner Limited General
- Attorney in Fact
- Trustee
- Other: _____



Signer is Representing:
All American Asphalt

Signer's Name: N/A

- Individual
- Corporate Officer -- Title(s): N/A
- Partner Limited General
- Attorney in Fact
- Trustee
- Other: N/A



Signer is Representing:
N/A

ZURICH AMERICAN INSURANCE COMPANY
COLONIAL AMERICAN CASUALTY AND SURETY COMPANY
FIDELITY AND DEPOSIT COMPANY OF MARYLAND
POWER OF ATTORNEY

KNOW ALL MEN BY THESE PRESENTS: That the ZURICH AMERICAN INSURANCE COMPANY, a corporation of the State of New York, the COLONIAL AMERICAN CASUALTY AND SURETY COMPANY, a corporation of the State of Illinois, and the FIDELITY AND DEPOSIT COMPANY OF MARYLAND a corporation of the State of Illinois (herein collectively called the "Companies"), by Robert D. Murray, Vice President, in pursuance of authority granted by Article V, Section 8, of the By-Laws of said Companies, which are set forth on the reverse side hereof and are hereby certified to be in full force and effect on the date hereof, do hereby nominate, constitute, and appoint William SYRKIN, Richard ADAIR, Rebecca HAAS-BATES of Irvine, California, its true and lawful agent and Attorney-in-Fact, to make, execute, seal and deliver, for, and on its behalf as surety, and as its act and deed: **any and all bonds and undertakings**, and the execution of such bonds or undertakings in pursuance of these presents, shall be as binding upon said Companies, as fully and amply, to all intents and purposes, as if they had been duly executed and acknowledged by the regularly elected officers of the ZURICH AMERICAN INSURANCE COMPANY at its office in New York, New York, the regularly elected officers of the COLONIAL AMERICAN CASUALTY AND SURETY COMPANY at its office in Owings Mills, Maryland, and the regularly elected officers of the FIDELITY AND DEPOSIT COMPANY OF MARYLAND at its office in Owings Mills, Maryland, in their own proper persons.

The said Vice President does hereby certify that the extract set forth on the reverse side hereof is a true copy of Article V, Section 8, of the By-Laws of said Companies, and is now in force.

IN WITNESS WHEREOF, the said Vice-President has hereunto subscribed his/her names and affixed the Corporate Seals of the said ZURICH AMERICAN INSURANCE COMPANY, COLONIAL AMERICAN CASUALTY AND SURETY COMPANY, and FIDELITY AND DEPOSIT COMPANY OF MARYLAND, this 11th day of October, A.D. 2023.



ATTEST:
ZURICH AMERICAN INSURANCE COMPANY
COLONIAL AMERICAN CASUALTY AND SURETY COMPANY
FIDELITY AND DEPOSIT COMPANY OF MARYLAND

By: *Robert D. Murray*
Vice President

By: *Dawn E. Brown*
Secretary

State of Maryland
County of Baltimore

On this 11th day of October, A.D. 2023, before the subscriber, a Notary Public of the State of Maryland, duly commissioned and qualified, **Robert D. Murray, Vice President and Dawn E. Brown, Secretary** of the Companies, to me personally known to be the individuals and officers described in and who executed the preceding instrument, and acknowledged the execution of same, and being by me duly sworn, depose and saith, that he/she is the said officer of the Company aforesaid, and that the seals affixed to the preceding instrument are the Corporate Seals of said Companies, and that the said Corporate Seals and the signature as such officer were duly affixed and subscribed to the said instrument by the authority and direction of the said Corporations.

IN TESTIMONY WHEREOF, I have hereunto set my hand and affixed my Official Seal the day and year first above written.

Genevieve M. Maison

GENEVIEVE M. MAISON
NOTARY PUBLIC
BALTIMORE COUNTY MD
My Commission Expires JANUARY 27 2025



Authenticity of this bond can be confirmed at bondvalidator.zurichna.com or 410-559-8790

EXTRACT FROM BY-LAWS OF THE COMPANIES

"Article V, Section 8, Attorneys-in-Fact. The Chief Executive Officer, the President, or any Executive Vice President or Vice President may, by written instrument under the attested corporate seal, appoint attorneys-in-fact with authority to execute bonds, policies, recognizances, stipulations, undertakings, or other like instruments on behalf of the Company, and may authorize any officer or any such attorney-in-fact to affix the corporate seal thereto; and may with or without cause modify or revoke any such appointment or authority at any time."

CERTIFICATE

I, the undersigned, Vice President of the ZURICH AMERICAN INSURANCE COMPANY, the COLONIAL AMERICAN CASUALTY AND SURETY COMPANY, and the FIDELITY AND DEPOSIT COMPANY OF MARYLAND, do hereby certify that the foregoing Power of Attorney is still in full force and effect on the date of this certificate; and I do further certify that Article V, Section 8, of the By-Laws of the Companies is still in force.

This Power of Attorney and Certificate may be signed by facsimile under and by authority of the following resolution of the Board of Directors of the ZURICH AMERICAN INSURANCE COMPANY at a meeting duly called and held on the 15th day of December 1998.

RESOLVED: "That the signature of the President or a Vice President and the attesting signature of a Secretary or an Assistant Secretary and the Seal of the Company may be affixed by facsimile on any Power of Attorney...Any such Power or any certificate thereof bearing such facsimile signature and seal shall be valid and binding on the Company."

This Power of Attorney and Certificate may be signed by facsimile under and by authority of the following resolution of the Board of Directors of the COLONIAL AMERICAN CASUALTY AND SURETY COMPANY at a meeting duly called and held on the 5th day of May, 1994, and the following resolution of the Board of Directors of the FIDELITY AND DEPOSIT COMPANY OF MARYLAND at a meeting duly called and held on the 10th day of May, 1990.

RESOLVED: "That the facsimile or mechanically reproduced seal of the company and facsimile or mechanically reproduced signature of any Vice-President, Secretary, or Assistant Secretary of the Company, whether made heretofore or hereafter, wherever appearing upon a certified copy of any power of attorney issued by the Company, shall be valid and binding upon the Company with the same force and effect as though manually affixed.

IN TESTIMONY WHEREOF, I have hereunto subscribed my name and affixed the corporate seals of the said Companies, this 6th day of December, 2023.



Thomas O. McClellan
Vice President

TO REPORT A CLAIM WITH REGARD TO A SURETY BOND, PLEASE SUBMIT A COMPLETE DESCRIPTION OF THE CLAIM INCLUDING THE PRINCIPAL ON THE BOND, THE BOND NUMBER, AND YOUR CONTACT INFORMATION TO:

Zurich Surety Claims
1299 Zurich Way
Schaumburg, IL 60196-1056
reportsfclaims@zurichna.com
800-626-4577

Authenticity of this bond can be confirmed at bondvalidator.zurichna.com or 410-559-8790

Company Profi

Company Profile Search Lines of Insurance Search Other Insurance Entities

Reset
Company Pr
Search

Company Profile

FIDELITY AND DEPOSIT COMPANY OF
MARYLAND

Company Com

1299 Zurich Way, Schaumburg, IL
60196-5870

Company Pe
& Compari

800-382-2150

Enforcement

Consumer C
Stud

[Show All](#) [Name History](#) [Agent for Service](#) [Reference Information](#) [Lines of Bus](#)

Workers' Comp

Name History

Workers' Coi
Complaint &
for Action
Contact In

Legal Name	Name Status	Effective Date
FIDELITY AND DEPOSIT COMPANY OF MARYLAND	Current	

Additional Infor

View
Financial Dis

Agent for Service

Full Name	Attn Or C/O	Full Address	Contact Phone	Effective From Date
Melissa DeKoven	Corporation Service Company	2710 Gateway Oaks Drive, Suite 150N, Sacramento, CA 95833-3505	888-690-2882	06/11/2019

Reference Information

Identification	Classification	Location
Company ID (EID)	Category	State Name
6217	Insurer	Illinois
CA #	Category Type	Origin
2479-4	Property & Casualty	Foreign
NAIC	Status	Country
39306	Unlimited-Normal	-
NAIC Group	License Category	Form
212	Admitted	Stock
NAIC Group Name		
ZURICH INS GRP		

Lines of Business

The company is authorized to transact business within these lines of insurance. For an explanation of any of these terms, please refer to the [glossary](#).

Lines of Business

Marine

Surety

Liability

Workers' Compensation

Boiler And Machinery

Lines of Business

Burglary
Credit
Sprinkler
Team And Vehicle
Automobile
Aircraft
Miscellaneous
Fire
Plate Glass

Financial Statements

* Year

California Department of Insurance Disclaimer

The Annual and Quarterly Financial Statements are submitted to the California Department of Insurance ("CDI") pursuant to California Insurance Code Sections 900 and 931 and California Code of Regulations Section 2308.1. The information is furnished to the CDI by California admitted insurers and is provided to the public "AS IS" pursuant to California Insurance Code Section 12921.2.

The CDI does not guarantee the truth, accuracy, adequacy or completeness of the data contained in the insurers' Annual and Quarterly Financial Statements and expressly disclaims any liability for any errors, omissions, or the result obtained from the use of such data.

Individuals who are unable to access the Annual and Quarterly Financial Statements may contact the CDI at CustodianofRecords@insurance.ca.gov for additional information.

[Privacy Policy](#)

[ADA Compliance](#)

[Site Map](#)

[Employment Opportunities](#)

[Internships](#)

[Free Document Readers](#)

[Scheduled Site Maintenance](#)



*Patricia Romo
Interim Director
of Transportation*

COUNTY OF RIVERSIDE

TRANSPORTATION AND LAND MANAGEMENT AGENCY

*Dennis Acuna, P.E.
Deputy for Transportation/Capital
Projects*

*Russell Williams
Deputy for Transportation/Planning and
Development*

Transportation Department

ADDENDUM NUMBER 2

Dated January 4, 2024

**to the
Specifications and Contract Documents
for the construction of**

**Lakepointe Drive Reconstruction
Indiana Avenue to Southern Sun Summit Drive
Community of Lake Hills
Project No. D2-0049**

**Bids Due: (Revised)
Wednesday, January 17, 2024; 2:00 p.m.
14th Street Transportation Annex
3525 14th Street; Riverside, CA 92501
(951) 955-6780**

This Addendum is issued pursuant to the Instructions to Bidders, Item No. 8, of the Contract Documents for the reference project. This Addendum is issued as a supplement to the specification and special provisions for the referenced project. The revisions to the specifications shall become a part of the Contract Documents, and each bidder shall acknowledge receipt thereof on the Bid (Proposal). Bidders are directed to sign this addendum as acknowledged and attach the signed addendum to the contractor's submitted proposal.

Note: During the advertisement period of this project, this document and attachments (if any) are available upon request at the office of the Transportation Department, and are available as a free download at the Transportation Department's website:

<https://trans.rctlma.org/notices-inviting-bids>

MODIFICATIONS / CLARIFICATIONS TO SPECIAL PROVISIONS:

Item 1: The new designated date and time for the receipt and opening of bids is revised as follows:

**Wednesday, January 17, 2024; 2:00 p.m.
14th Street Transportation Annex
3525 14th Street; Riverside, CA 92501
(951) 955-6780**

Item 2: Revised Proposal. Refer to "Proposal" pages B2-B3. Delete and replace "Proposal" (pages B2 through B3) with "Proposal (Revised)" attached herewith as **Attachment "A"**. The following changes have been made to the Proposal:

Note: Revisions made to the proposal are written with blue font / blue numbers in Attachment "A".

a. Estimated Quantities have been revised for the following bid items:

- Item 6, ROADWAY EXCAVATION
- Item 14, HOT MIX ASPHALT (TYPE A)
- Item 15, MINOR CONCRETE (SIDEWALK)

This addendum has been prepared under the direction of the following registered Civil Engineer(s):

Recommended by:

Mike Heath

Mike Heath, PE
Engineering Project Manager

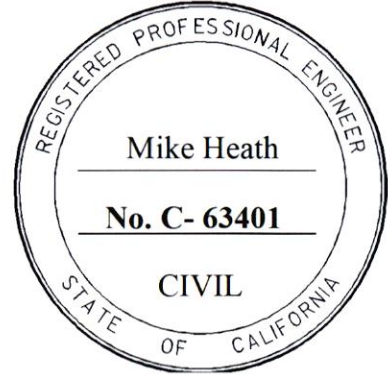

Concurrence:

Dennis Acuna

Dennis Acuna, PE, TE
Deputy Director

Acknowledged:

Edward J. Carlson

(Contractor)
Edward J. Carlson, Vice President

Date: 1-4-24

JRJ: jrj:jr

Note: Refer to Instruction to Bidders Item No. 8, "Addenda". Submission of all addendum pages and non-bidding document attachments of addendum are not necessary for Bid submittal. Submittal of this acknowledgement page is adequate for Bid reception. Bidders are reminded to list addendum number(s) received on the first page of the Bid form (Proposal).

Contract

THIS CONTRACT is entered into at Riverside, California as of the date set forth below is between County of Riverside hereafter called "County" and All American Asphalt, hereafter called "Contractor".

WITNESSETH

Recitals:

1. Contractor has submitted to County his Contractor's Proposal for the construction of County Project, Lakepointe Drive Reconstruction, Indiana Avenue to Southern Sun Summit Drive, Community of Lake Hills, Project No. D2-0049, in strict accordance with the Contract Documents identified below and County has accepted said Proposal.
2. Contractor states that he has reexamined his Contractor's Proposal and found it to be correct, has ascertained that his subcontractors are properly licensed and possess the requisite skill and forces, has reexamined the site and Contract Documents and is of the opinion that he can presently do the work in accordance with the Contract Documents for the money set forth in his Proposal to be paid as provided in the Contract Documents.

Agreement:

It is agreed by the parties as follows:

1. Contract Documents

The entire Contract consists of the following: (a) The Construction Contract, (b) The Notice to Bidders, (c) The Instruction to Bidders, (d) The Bid, (e) The Bid Bond, (f) The Payment Bond, (g) The Performance Bond, (h) The General Conditions, (i) The Special Provisions, (j) The Standard Specifications of the State of California Department of Transportation edition of 2018 as modified in other portions of the Contract Documents and as amended by the State of California Department of Transportation, (k) The Standard Plans of the Department of Transportation identified on the plans or in the Special Provisions, (l) The Plans, (m) Addenda (Two), (n) The Determination of Prevailing Wage Rates for Public Works, (o) Any Change Orders issued, and (p) Any additional or supplemental specifications, notice, instructions and drawings issued in accordance with the provisions of the Contract Documents. All of said Documents presently in existence are by this reference incorporated herein with like effect as if here set forth in full and upon the proper issuance of other documents they shall likewise be deemed incorporated. The Bid Bond is exonerated upon execution of this Contract and the Payment Bond and Performance Bond.

2. The Work

Contractor shall do all tasks necessary to construct the work generally described in Recital No. 1 in accordance with the Contract Documents.

3. Prosecution, Progress and Liquidated Damages

Attention is directed to the provisions in Section 8-1.04, "Start of Job Site Activities", Section 8-1.05, "Time", and in Section 8-1.10 "Liquidated Damages" of the Standard Specifications and these Special Provisions.

Standard Specification Section 8-1.04B, "Standard Start" is modified to read as follows:

The Contractor shall begin work within fifteen (15) calendar days, or as revised in the Special Provisions, of the date stated within the written "Notice to Proceed".

The Contractor shall notify the Engineer, in writing, of the Contractor's intent to begin work at least 72 hours before work is begun. If the project has more than one (1) location of work, Contractor shall submit a separate notice for each location. The notice shall be delivered to the Transportation Department's Construction Engineer and shall specify the date the Contractor intends to start at said location.

Should the Contractor begin work in advance of receiving a written "Notice to Proceed", any work performed by the Contractor in advance of the date stated in the "Notice to Proceed" shall be considered as having been done by the Contractor at his own risk and as a volunteer and subject to the following:

- A. The Contractor shall, on commencing operations, take all precautions required for public safety and shall observe all the provisions in the Specifications and the Special Provisions.
- B. All work done according to the Contract, prior to the issuance of the "Notice to Proceed", will be considered authorized work and will be paid for as provided in the contract.
- C. The Contractor shall not be entitled to any additional compensation or an extension of time for any delay, hindrance or interference caused by or attributable to commencement of work prior to the issuance of the "Notice to Proceed".

4. Compensation

Contractor shall be paid in the manner set forth in the Contract Documents the amount of his Proposal as accepted by County, the above rates, subject to additions and deductions as provided in the Contract Documents. Said Proposal is on file in the Office of the Clerk of the Board of Supervisors of County.

**Lakepointe Drive Reconstruction
Indiana Avenue to Southern Sun Summit Drive
Community of Lake Hills
Project No. D2-0049**

Contract

ITEM No.	ITEM CODE	ITEM	UNIT	ESTIMATED QUANTITY	ITEM PRICE (IN FIGURES)	TOTAL (IN FIGURES)
BASE BID SCHEDULE - Lakepointe Drive Reconstruction						
1	066100	DUST ABATEMENT	LS	1	5,000.00	5,000.00
2	100100	DEVELOP WATER SUPPLY	LS	1	3,000.00	3,000.00
3	120100	TRAFFIC CONTROL SYSTEM	LS	1	220,000.00	220,000.00
4	130200	PREPARE WATER POLLUTION CONTROL PROGRAM	LS	1	8,880.85	8,880.85
5	170103	CLEARING AND GRUBBING	LS	1	15,000.00	15,000.00
6	190101(F)	ROADWAY EXCAVATION	CY	3,891	70.00	272,370.00
7	260203	CLASS 2 AGGREGATE BASE	CY	390	54.00	21,060.00
8	198215	SUBGRADE ENHANCEMENT GEOGRID	SQYD	2,330	4.00	9,320.00
9	729011	ROCK SLOPE PROTECTION FABRIC (CLASS 8)	SQYD	468	2.00	936.00
10	680287	3" SLOTTED PLASTIC PIPE UNDERDRAIN [SCH 80]	LF	545	76.00	41,420.00
11	681107	3" PLASTIC PIPE (EDGE DRAIN OUTLET) [SCH 80]	LF	40	300.00	12,000.00
12	710212	ADJUST MANHOLE TO GRADE [STORM DRAIN]	EA	12	1,400.00	16,800.00
13	720110	SMALL-ROCK SLOPE PROTECTION [PERMEABLE MATERIAL - CRUSHED ROCK]	CY	23	140.00	3,220.00
14	390132	HOT MIX ASPHALT (TYPE A)	TON	7,647	102.00	779,994.00
15	731521	MINOR CONCRETE (SIDEWALK)	SQFT	874	14.00	12,236.00
15.A	017315	MINOR CONCRETE (CURB RAMP) (CRS 403 - CASE A)	EA	16	8,800.00	140,800.00
15.B	017317	MINOR CONCRETE (CROSS-GUTTER AND SPANDREL)	SQFT	2,980	26.00	77,480.00

Contract (Continued)

ITEM No.	ITEM CODE	ITEM	UNIT	ESTIMATED QUANTITY	ITEM PRICE (IN FIGURES)	TOTAL (IN FIGURES)
BASE BID SCHEDULE - Lakepointe Drive Reconstruction (Continued)						
16	017304	MINOR CONCRETE (CURB AND GUTTER) (CRS 200)	LF	30	80.00	2,400.00
17	017310	MINOR CONCRETE (DRIVEWAY APPROACH) (CRS 207)	SQFT	400	20.00	8,000.00
18	000001	ITEM DELETED PER ADDENDUM No. 2	-----	-----	-----	-----
19	820410	SALVAGE ROADSIDE SIGN	EA	16	100.00	1,600.00
20	820840	ROADSIDE SIGN - ONE POST	EA	20	375.00	7,500.00
21	810230(F)	PAVEMENT MARKER (RETROREFLECTIVE)	EA	370	8.50	3,145.00
22	840519	THERMOPLASTIC CROSSWALK AND PAVEMENT MARKING	SQFT	905	5.75	5,203.75
23	840656(F)	PAINT TRAFFIC STRIPE (2-COAT)	LF	4,620	0.75	3,465.00
24	010602	MISCELLANEOUS WORK (AS DIRECTED)	FA	1	85,000.00	85,000.00

BASE BID SCHEDULE: One million, seven hundred fifty-five thousand, eight hundred thirty dollars and sixty cents **\$1,755,830.60**
 ITEMS 1 - 24 "WORDS"

ALTERNATIVE BID SCHEDULE 1 - Western Municipal Water District (WMWD) Facility Adjustments

25	710228	ADJUST SEWER MANHOLE	EA	16	347.00	5,552.00
----	--------	----------------------	----	----	--------	----------

ALT. BID SCHEDULE 1: Five thousand, five hundred fifty-two dollars and zero cents **\$5,552.00**
 ITEM 25 "WORDS"

PROJECT TOTAL: One million, seven hundred sixty-one thousand, three hundred eighty-two dollars and sixty cents **\$1,761,382.60**
 ITEMS 1 - 25 "WORDS"

Lakepointe Drive Reconstruction
Indiana Avenue to Southern Sun Summit Drive
Community of Lake Hills
Project No. D2-0049

IN WITNESS WHEREOF the parties hereto have executed this Contract as of the date set forth below.

COUNTY OF RIVERSIDE

BY: *Chuck Washington*
CHUCK WASHINGTON
Chair, Board of Supervisors

DATED: 4/09/2024

ATTEST:

Kimberly A. Rector, Clerk of the Board

BY: *Naomy Li*
Deputy

FORM APPROVED COUNTY COUNSEL
BY: *Danielle D. Maland*
DANIELLE D. MALAND

ALL AMERICAN ASPHALT

BY: *Edward J. Carlson*

TITLE: Edward J. Carlson, V.P.
(If Corporation, affix Seal)

ATTEST:

Michael Farkas

TITLE: Michael Farkas, Secretary

Licensed in accordance with an act providing for the registration of Contractors,

License No.: 267073

Federal Employer Identification Number:
95-2595043

Department of Industrial Relations Registration Number:
1000001051

BY _____
"County"

All American Asphalt
"Corporation"
(Seal)



CALIFORNIA ALL-PURPOSE ACKNOWLEDGEMENT

CIVIL CODE § 1189

A notary public or other officer completing this certificate verifies only the identity of the individual who signed the document to which this certificate is attached, and not the truthfulness, accuracy, or validity of that document.

State of California

County of Riverside

On February 7, 2024 before me, Sarah Amanda Langley, Notary Public
Date Here insert name and Title of the Officer

personally appeared Edward J. Carlson and Michael Farkas
Name(s) of Signer(s)

who proved to me on the basis of satisfactory evidence to be the person(s) whose name(s) is/are subscribed to the within instrument and acknowledged to me that he/she/they executed the same in his/her/their authorized capacity(ies), and that by his/her/their signature(s) on the instrument the person(s), or the entity upon behalf of which the person(s) acted, executed the instrument.



I certify under PENALTY OF PERJURY under the laws of the State of California that the foregoing paragraph is true and correct.

WITNESS my hand and official seal.

Signature Sarah Amanda Langley
Signature of Notary Public

Place Notary Seal Above

OPTIONAL

Though the information below is not required by law, it may prove valuable to person relying on the document and could prevent fraudulent removal and reattachment of this form to another document.

Description of Attached Document

Title or Type of Document Executed Contract

Document Date: 02/07/2024 Number of Pages: 1

Signer(s) Other Than Named Above: _____

Capacity(ies) Claimed by Signer(s)

Signer's Name: Edward J. Carlson

- Individual
- Corporate Officer — Title(s): Vice President
- Partner Limited General
- Attorney in Fact
- Trustee
- Other: _____

Signer is Representing:

All American Asphalt

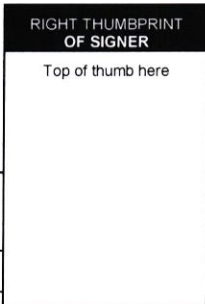

Signer's Name: Michael Farkas

- Individual
- Corporate Officer — Title(s): Secretary
- Partner Limited General
- Attorney in Fact
- Trustee
- Other: _____

Signer is Representing:

All American Asphalt





ALL AMERICAN ASPHALT
ALL AMERICAN AGGREGATES

T 951-736-7600 F 951-739-4671
P.O. BOX 2029 CORONA, CA 92878-2029
CONTRACTORS LICENSE #267873 (A/C/L)
DIR #1000001051

CORPORATE RESOLUTION

Resolved, that this Corporation, All American Asphalt, on January 3, 2022 authorizes Edward J. Carlson to execute bid proposals, contracts and agreements on behalf of the company in the capacity of Vice President.



Michael Farkas
Secretary

Performance Bond

Recitals:

1. **All American Asphalt** (Contractor) has entered into a Contract with COUNTY OF RIVERSIDE (County) for construction of public work known as **Lakepointe Drive Reconstruction, Indiana Avenue to Southern Sun Summit Drive, Community of Lake Hills, Project No. D2-0049.**
2. _____, a _____ corporation (Surety), is the Surety under this Bond.

Agreement:

We, Contractor as Principal and Surety as Surety, jointly and severally agree, state, and are bound unto County, as obligee, as follows:

1. The amount of the obligation of this Bond is 100% of the estimated contract price for the Project of **\$1,761,382.60 (One million, seven hundred sixty-one thousand, three hundred eighty-two dollars and sixty cents)** and inures to the benefit of County.
2. This Bond is exonerated by Contractor doing all things to be kept and performed by it in strict conformance with the Contract Documents for this project, otherwise it remains in full force and effect for the recovery of loss, damage and expense of County resulting from failure of Contractor to so act. All of said Contract Documents are incorporated herein.
3. This obligation is binding on our successors and assigns.
4. For value received, Surety stipulates and agrees that no change, time extension, prepayment to Contractor, alteration or addition to the terms and requirements of the Contract Documents or the work to be performed thereunder shall affect its obligations hereunder and waives notice as to such matters, except the total contract price cannot be increased by more than 10% without approval of Surety.

THIS BOND is executed as of _____.

By _____

By _____

By _____

Type Name _____

Its Attorney in Fact
"Surety"

Title _____

"Contractor"

(Corporate Seal)

(Corporate Seal)

NOTE: This Bond must be executed by both parties with corporate seal affixed. All signatures must be acknowledged. (Attach acknowledgements).

Payment Bond

(Public Works - Civil Code §9550 et seq.)

The makers of this Bond are All American Asphalt as Principal and Original Contractor and _____, a corporation, authorized to issue Surety Bonds in California, as Surety, and this Bond is issued in conjunction with that certain public works contract to be executed between Principal and COUNTY OF RIVERSIDE a public entity, as Owner, for \$1,761,382.60 (One million, seven hundred sixty-one thousand, three hundred eighty-two dollars and sixty cents) the total amount payable. The amount of this bond is one hundred percent (100%) of said sum. Said contract is for public work generally consisting of Lakepointe Drive Reconstruction, Indiana Avenue to Southern Sun Summit Drive, Community of Lake Hills, Project No. D2-0049.

The beneficiaries of this Bond are as is stated in 9554 of the Civil Code and requirements and conditions of this Bond are as is set forth in 9554, 9558, 9560 and 9564 of said code. Without notice, Surety consents to extension of time for performance, change in requirements, amount of compensation, or prepayment under said contract.

Dated: _____

Original Contractor – Principal

Surety

By _____

By _____
Its Attorney In Fact

Title _____
(If corporation, affix seal)

(Corporate Seal)

(Corporate Seal)

STATE
OF _____
COUNTY _____
OF _____

} ss. SURETY'S ACKNOWLEDGEMENT

On _____ before me, _____ personally appeared, _____, known to me, or proved to me on the basis of satisfactory evidence, to be the person whose name is subscribed to the within instrument and acknowledged to me that he executed the same in his authorized capacities, and that by his signature on the instrument the person, or the entity upon behalf of which the person acted, executed the instrument.

WITNESS my hand and official seal.

Signature of Notary Public

Notary Public (Seal)

NOTE: This Bond must be executed by both parties with corporate seal affixed. All signatures must be acknowledged. (Attach acknowledgements).

Performance Bond

Recitals:

1. **All American Asphalt** (Contractor) has entered into a Contract with COUNTY OF RIVERSIDE (County) for construction of public work known as **Lakepointe Drive Reconstruction, Indiana Avenue to Southern Sun Summit Drive, Community of Lake Hills, Project No. D2-0049**.
2. Fidelity and Deposit Company of Maryland, a Illinois corporation (Surety), is the Surety under this Bond.

Agreement:

We, Contractor as Principal and Surety as Surety, jointly and severally agree, state, and are bound unto County, as obligee, as follows:

1. The amount of the obligation of this Bond is 100% of the estimated contract price for the Project of **\$1,761,382.60 (One million, seven hundred sixty-one thousand, three hundred eighty-two dollars and sixty cents)** and inures to the benefit of County.
2. This Bond is exonerated by Contractor doing all things to be kept and performed by it in strict conformance with the Contract Documents for this project, otherwise it remains in full force and effect for the recovery of loss, damage and expense of County resulting from failure of Contractor to so act. All of said Contract Documents are incorporated herein.
3. This obligation is binding on our successors and assigns.
4. For value received, Surety stipulates and agrees that no change, time extension, prepayment to Contractor, alteration or addition to the terms and requirements of the Contract Documents or the work to be performed thereunder shall affect its obligations hereunder and waives notice as to such matters, except the total contract price cannot be increased by more than 10% without approval of Surety.

THIS BOND is executed as of February 2, 2024
All American Asphalt Fidelity and Deposit Company of Maryland

By _____ By Rebecca Haas-Bates

By [Signature] Type Name Rebecca Haas-Bates

Title Edward J. Carlson, VP

"Contractor"

(Corporate Seal)

Its Attorney in Fact
"Surety"

(Corporate Seal)

NOTE: This Bond must be executed by both parties with corporate seal affixed. All signatures must be acknowledged. (Attach acknowledgements).

CALIFORNIA ALL-PURPOSE ACKNOWLEDGEMENT

CIVIL CODE § 1189

A notary public or other officer completing this certificate verifies only the identity of the individual who signed the document to which this certificate is attached, and not the truthfulness, accuracy, or validity of that document.

State of California

County of Riverside

On February 7, 2024 before me, Sarah Amanda Langley, Notary Public
Date Here insert name and Title of the Officer

personally appeared Edward J. Carlson
Name of Signer



who proved to me on the basis of satisfactory evidence to be the person(s) whose name(s) is/are subscribed to the within instrument and acknowledged to me that he/she/they executed the same in his/her/their authorized capacity(ies), and that by his/her/their signature(s) on the instrument the person(s), or the entity upon behalf of which the person(s) acted, executed the instrument.

I certify under PENALTY OF PERJURY under the laws of the State of California that the forgoing paragraph is true and correct.

WITNESS my hand and official seal.

Signature Sarah Amanda Langley
Signature of Notary Public

Place Notary Seal Above

OPTIONAL

Though the information below is not required by law, it may prove valuable to person relying on the document and could prevent fraudulent removal and reattachment of this form to another document.

Description of Attached Document

Title or Type of Document Performance Bond

Document Date: 02/02/2024 Number of Pages: 3

Signer(s) Other Than Named Above: Rebecca Haas-Bates, Attorney in Fact

Capacity(ies) Claimed by Signer(s)

Signer's Name: Edward J. Carlson

- Individual
- Corporate Officer — Title(s): Vice President
- Partner Limited General
- Attorney in Fact
- Trustee
- Other: _____

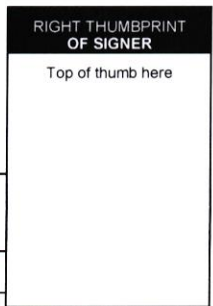

Signer is Representing:
All American Asphalt

Signer's Name: N/A

- Individual
- Corporate Officer — Title(s): N/A
- Partner Limited General
- Attorney in Fact
- Trustee
- Other: N/A

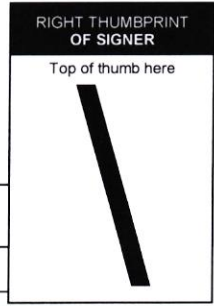

Signer is Representing:
N/A

CALIFORNIA ALL-PURPOSE ACKNOWLEDGMENT

CIVIL CODE § 1189

A notary public or other officer completing this certificate verifies only the identity of the individual who signed the document to which this certificate is attached, and not the truthfulness, accuracy, or validity of that document.

State of California)
County of Orange)

On 02/02/2024 before me, L. Gomez, Notary Public
Date Here Insert Name and Title of the Officer

personally appeared Rebecca Haas-Bates
Name(s) of Signer(s)

who proved to me on the basis of satisfactory evidence to be the person(s) whose name(s) is/are subscribed to the within instrument and acknowledged to me that he/she/they executed the same in his/her/their authorized capacity(ies), and that by his/her/their signature(s) on the instrument the person(s), or the entity upon behalf of which the person(s) acted, executed the instrument.

I certify under PENALTY OF PERJURY under the laws of the State of California that the foregoing paragraph is true and correct.

WITNESS my hand and official seal.

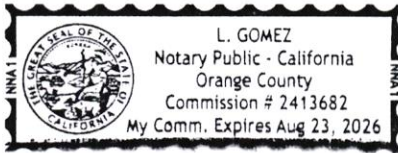

Signature *L. Gomez*
Signature of Notary Public

Place Notary Seal Above

OPTIONAL

Though this section is optional, completing this information can deter alteration of the document or fraudulent reattachment of this form to an unintended document.

Description of Attached Document

Title or Type of Document: Performance Bond No. 7671606 Document Date: 02/02/2024
Number of Pages: One (1) Signer(s) Other Than Named Above: All American Asphalt

Capacity(ies) Claimed by Signer(s)

Signer's Name: Rebecca Haas-Bates
 Corporate Officer — Title(s): _____
 Partner — Limited General
 Individual Attorney in Fact
 Trustee Guardian or Conservator
 Other: _____
Signer Is Representing: _____
Fidelity and Deposit Company of Maryland _____

Signer's Name: _____
 Corporate Officer — Title(s): _____
 Partner — Limited General
 Individual Attorney in Fact
 Trustee Guardian or Conservator
 Other: _____
Signer Is Representing: _____

EXTRACT FROM BY-LAWS OF THE COMPANIES

"Article V, Section 8, Attorneys -in-Fact. The Chief Executive Officer, the President, or any Executive Vice President or Vice President may, by written instrument under the attested corporate seal, appoint attorneys-in-fact with authority to execute bonds, policies, recognizances, stipulations, undertakings, or other like instruments on behalf of the Company, and may authorize any officer or any such attorney-in-fact to affix the corporate seal thereto; and may with or without cause modify or revoke any such appointment or authority at any time."

CERTIFICATE

I, the undersigned, Vice President of the ZURICH AMERICAN INSURANCE COMPANY, the COLONIAL AMERICAN CASUALTY AND SURETY COMPANY, and the FIDELITY AND DEPOSIT COMPANY OF MARYLAND, do hereby certify that the foregoing Power of Attorney is still in full force and effect on the date of this certificate; and I do further certify that Article V, Section 8, of the By-Laws of the Companies is still in force.

This Power of Attorney and Certificate may be signed by facsimile under and by authority of the following resolution of the Board of Directors of the ZURICH AMERICAN INSURANCE COMPANY at a meeting duly called and held on the 15th day of December 1998.

RESOLVED: "That the signature of the President or a Vice President and the attesting signature of a Secretary or an Assistant Secretary and the Seal of the Company may be affixed by facsimile on any Power of Attorney...Any such Power or any certificate thereof bearing such facsimile signature and seal shall be valid and binding on the Company."

This Power of Attorney and Certificate may be signed by facsimile under and by authority of the following resolution of the Board of Directors of the COLONIAL AMERICAN CASUALTY AND SURETY COMPANY at a meeting duly called and held on the 5th day of May, 1994, and the following resolution of the Board of Directors of the FIDELITY AND DEPOSIT COMPANY OF MARYLAND at a meeting duly called and held on the 10th day of May, 1990.

RESOLVED: "That the facsimile or mechanically reproduced seal of the company and facsimile or mechanically reproduced signature of any Vice-President, Secretary, or Assistant Secretary of the Company, whether made heretofore or hereafter, wherever appearing upon a certified copy of any power of attorney issued by the Company, shall be valid and binding upon the Company with the same force and effect as though manually affixed.

IN TESTIMONY WHEREOF, I have hereunto subscribed my name and affixed the corporate seals of the said Companies, this 2nd day of February, 2024.



MJ Pethick

By: Mary Jean Pethick
Vice President

TO REPORT A CLAIM WITH REGARD TO A SURETY BOND, PLEASE SUBMIT A COMPLETE DESCRIPTION OF THE CLAIM INCLUDING THE PRINCIPAL ON THE BOND, THE BOND NUMBER, AND YOUR CONTACT INFORMATION TO:

Zurich Surety Claims
1299 Zurich Way
Schaumburg, IL 60196-1056
800-626-4577

If your jurisdiction allows for electronic reporting of surety claims, please submit to:
reportsfclaims@zurichna.com

Authenticity of this bond can be confirmed at bondvalidator.zurichna.com or 410-559-8790

Bond Number
County of Riverside
Obligee

**ZURICH AMERICAN INSURANCE COMPANY
COLONIAL AMERICAN CASUALTY AND SURETY COMPANY
FIDELITY AND DEPOSIT COMPANY OF MARYLAND
POWER OF ATTORNEY**

KNOW ALL MEN BY THESE PRESENTS: That the ZURICH AMERICAN INSURANCE COMPANY, a corporation of the State of New York, the COLONIAL AMERICAN CASUALTY AND SURETY COMPANY, a corporation of the State of Illinois, and the FIDELITY AND DEPOSIT COMPANY OF MARYLAND a corporation of the State of Illinois (herein collectively called the "Companies"), by **Robert D. Murray, Vice President**, in pursuance of authority granted by Article V, Section 8, of the By-Laws of said Companies, which are set forth on the reverse side hereof and are hereby certified to be in full force and effect on the date hereof, do hereby nominate, constitute, and appoint Rebecca Haas-Bates, its true and lawful agent and Attorney-in-Fact, to make, execute, seal and deliver, for, and on its behalf as surety, and as its act and deed: **any and all bonds and undertakings**, and the execution of such bonds or undertakings in pursuance of these presents, shall be as binding upon said Companies, as fully and amply, to all intents and purposes, as if they had been duly executed and acknowledged by the regularly elected officers of the ZURICH AMERICAN INSURANCE COMPANY at its office in New York, New York., the regularly elected officers of the COLONIAL AMERICAN CASUALTY AND SURETY COMPANY at its office in Owings Mills, Maryland., and the regularly elected officers of the FIDELITY AND DEPOSIT COMPANY OF MARYLAND at its office in Owings Mills, Maryland., in their own proper persons.

The said Vice President does hereby certify that the extract set forth on the reverse side hereof is a true copy of Article V, Section 8, of the By-Laws of said Companies, and is now in force.

IN WITNESS WHEREOF, the said Vice-President has hereunto subscribed his/her names and affixed the Corporate Seals of the said **ZURICH AMERICAN INSURANCE COMPANY, COLONIAL AMERICAN CASUALTY AND SURETY COMPANY, and FIDELITY AND DEPOSIT COMPANY OF MARYLAND**, this 2nd day of February, A.D. 2024 .



ATTEST:

**ZURICH AMERICAN INSURANCE COMPANY
COLONIAL AMERICAN CASUALTY AND SURETY COMPANY
FIDELITY AND DEPOSIT COMPANY OF MARYLAND**

By: *Robert D. Murray*
Vice President

By: *Dawn E. Brown*
Secretary

**State of Maryland
County of Baltimore**

On this 2nd day of February, A.D. 2024 , before the subscriber, a Notary Public of the State of Maryland, duly commissioned and qualified, **Robert D. Murray, Vice President and Dawn E. Brown, Secretary** of the Companies, to me personally known to be the individuals and officers described in and who executed the preceding instrument, and acknowledged the execution of same, and being by me duly sworn, depose and saith, that he/she is the said officer of the Company aforesaid, and that the seals affixed to the preceding instrument are the Corporate Seals of said Companies, and that the said Corporate Seals and the signature as such officer were duly affixed and subscribed to the said instrument by the authority and direction of the said Corporations.

IN TESTIMONY WHEREOF, I have hereunto set my hand and affixed my Official Seal the day and year first above written.

Genevieve M. Maison

**GENEVIEVE M. MAISON
NOTARY PUBLIC
BALTIMORE COUNTY, MD
My Commission Expires JANUARY 27, 2025**



- Company Profile
- Company Search
- Company Search Results
- Company Information
- Old Company Names
- Agent for Service Reference Information
- NAIC Group List
- Lines of Business
- Workers' Compensation Complaint and Request for Action/Appeals Contact Information
- Financial Statements PDF's
- Annual Statements
- Quarterly Statements
- Company Complaint
- Company Performance & Comparison Data
- Company Enforcement Action
- Composite Complaints Studies
- Additional Info
- Find A Company Representative In Your Area
- View Financial Disclaimer

COMPANY PROFILE
Company Information
FIDELITY AND DEPOSIT COMPANY OF MARYLAND

**1299 ZURICH WAY
SCHAUMBURG, IL 60196
800-382-2150**

Old Company Names
Effective Date
Agent For Service

Melissa DeKoven
2710 Gateway Oaks Drive, Suite 150N
Sacramento CA 95833-3505

Reference Information

NAIC #:	39306
California Company ID #:	2479-4
Date Authorized in California:	01/01/1982
License Status:	UNLIMITED-NORMAL
Company Type:	Property & Casualty
State of Domicile:	ILLINOIS

[back to top](#)
NAIC Group List

NAIC Group #: **0212** ZURICH INS GRP

Lines Of Business

The company is authorized to transact business within these lines of insurance. For an explanation of any of these terms, please refer to the [glossary](#).

- AIRCRAFT
- AUTOMOBILE
- BOILER AND MACHINERY
- BURGLARY
- CREDIT
- FIRE
- LIABILITY
- MARINE
- MISCELLANEOUS
- PLATE GLASS
- SPRINKLER
- SURETY
- TEAM AND VEHICLE
- WORKERS' COMPENSATION

Payment Bond

(Public Works - Civil Code §9550 et seq.)

The makers of this Bond are All American Asphalt as Principal and Original Contractor and Fidelity and Deposit Company of Maryland, a corporation, authorized to issue Surety Bonds in California, as Surety, and this Bond is issued in conjunction with that certain public works contract to be executed between Principal and COUNTY OF RIVERSIDE a public entity, as Owner, for \$1,761,382.60 (One million, seven hundred sixty-one thousand, three hundred eighty-two dollars and sixty cents) the total amount payable. The amount of this bond is one hundred percent (100%) of said sum. Said contract is for public work generally consisting of Lakepointe Drive Reconstruction, Indiana Avenue to Southern Sun Summit Drive, Community of Lake Hills, Project No. D2-0049.

The beneficiaries of this Bond are as is stated in 9554 of the Civil Code and requirements and conditions of this Bond are as is set forth in 9554, 9558, 9560 and 9564 of said code. Without notice, Surety consents to extension of time for performance, change in requirements, amount of compensation, or prepayment under said contract.

Dated: February 2, 2024

All American Asphalt
Original Contractor – Principal

Fidelity and Deposit Company of Maryland
Surety

By 

By 
Rebecca Haas-Bates
Its Attorney In Fact

Title Edward J. Carlson, VP
(If corporation, affix seal)

(Corporate Seal)

(Corporate Seal)

STATE _____
OF Please See Attached**
COUNTY _____
OF _____

} ss. SURETY'S ACKNOWLEDGEMENT

On _____ before me, _____ personally appeared, _____, known to me, or proved to me on the basis of satisfactory evidence, to be the person whose name is subscribed to the within instrument and acknowledged to me that he executed the same in his authorized capacities, and that by his signature on the instrument the person, or the entity upon behalf of which the person acted, executed the instrument.

WITNESS my hand and official seal.

Signature of Notary Public

Notary Public (Seal)

NOTE: This Bond must be executed by both parties with corporate seal affixed. All signatures must be acknowledged. (Attach acknowledgements).

CALIFORNIA ALL-PURPOSE ACKNOWLEDGEMENT

CIVIL CODE § 1189

A notary public or other officer completing this certificate verifies only the identity of the individual who signed the document to which this certificate is attached, and not the truthfulness, accuracy, or validity of that document.

State of California

County of Riverside

On February 7, 2024 before me, Sarah Amanda Langley, Notary Public
Date Here Insert name and Title of the Officer

personally appeared Edward J. Carlson
Name of Signer(s)

who proved to me on the basis of satisfactory evidence to be the person(s) whose name(s) is/are subscribed to the within instrument and acknowledged to me that he/she/they executed the same in his/her/their authorized capacity(ies), and that by his/her/their signature(s) on the instrument the person(s), or the entity upon behalf of which the person(s) acted, executed the instrument.

I certify under PENALTY OF PERJURY under the laws of the State of California that the forgoing paragraph is true and correct.

WITNESS my hand and official seal.

Signature Sarah Amanda Langley
Signature of Notary Public



Place Notary Seal Above

OPTIONAL

Though the information below is not required by law, it may prove valuable to person relying on the document and could prevent fraudulent removal and reattachment of this form to another document.

Description of Attached Document

Title or Type of Document Payment Bond

Document Date: 02/02/2024 Number of Pages: 3

Signer(s) Other Than Named Above: Rebecca Haas-Bates, Attorney in Fact

Capacity(ies) Claimed by Signer(s)

Signer's Name: Edward J. Carlson

- Individual
- Corporate Officer — Title(s): Vice President
- Partner Limited General
- Attorney in Fact
- Trustee
- Other: _____

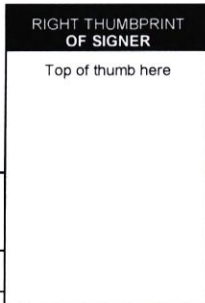

Signer is Representing:

All American Asphalt

Signer's Name: N/A

- Individual
- Corporate Officer — Title(s): N/A
- Partner Limited General
- Attorney in Fact
- Trustee
- Other: N/A

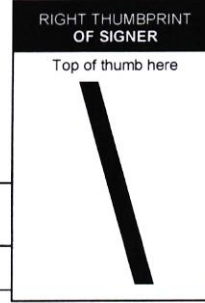

Signer is Representing:

N/A

CALIFORNIA ALL-PURPOSE ACKNOWLEDGMENT

CIVIL CODE § 1189

A notary public or other officer completing this certificate verifies only the identity of the individual who signed the document to which this certificate is attached, and not the truthfulness, accuracy, or validity of that document.

State of California)
County of Orange)

On 02/02/2024 before me, L. Gomez, Notary Public
Date Here Insert Name and Title of the Officer

personally appeared Rebecca Haas-Bates
Name(s) of Signer(s)

who proved to me on the basis of satisfactory evidence to be the person(s) whose name(s) is/are subscribed to the within instrument and acknowledged to me that he/she/they executed the same in his/her/their authorized capacity(ies), and that by his/her/their signature(s) on the instrument the person(s), or the entity upon behalf of which the person(s) acted, executed the instrument.

I certify under PENALTY OF PERJURY under the laws of the State of California that the foregoing paragraph is true and correct.

WITNESS my hand and official seal.

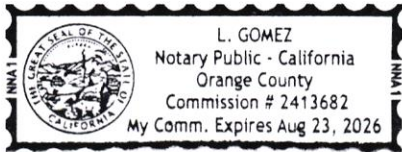

Signature *L. Gomez*
Signature of Notary Public

Place Notary Seal Above

OPTIONAL

Though this section is optional, completing this information can deter alteration of the document or fraudulent reattachment of this form to an unintended document.

Description of Attached Document

Title or Type of Document: Payment Bond No. 7671606 Document Date: 02/02/2024
Number of Pages: One (1) Signer(s) Other Than Named Above: All American Asphalt

Capacity(ies) Claimed by Signer(s)

Signer's Name: Rebecca Haas-Bates
 Corporate Officer — Title(s): _____
 Partner — Limited General
 Individual Attorney in Fact
 Trustee Guardian or Conservator
 Other: _____
Signer Is Representing: _____
Fidelity and Deposit Company of Maryland _____

Signer's Name: _____
 Corporate Officer — Title(s): _____
 Partner — Limited General
 Individual Attorney in Fact
 Trustee Guardian or Conservator
 Other: _____
Signer Is Representing: _____

EXTRACT FROM BY-LAWS OF THE COMPANIES

"Article V, Section 8, Attorneys -in-Fact. The Chief Executive Officer, the President, or any Executive Vice President or Vice President may, by written instrument under the attested corporate seal, appoint attorneys-in-fact with authority to execute bonds, policies, recognizances, stipulations, undertakings, or other like instruments on behalf of the Company, and may authorize any officer or any such attorney-in-fact to affix the corporate seal thereto; and may with or without cause modify or revoke any such appointment or authority at any time."

CERTIFICATE

I, the undersigned, Vice President of the ZURICH AMERICAN INSURANCE COMPANY, the COLONIAL AMERICAN CASUALTY AND SURETY COMPANY, and the FIDELITY AND DEPOSIT COMPANY OF MARYLAND, do hereby certify that the foregoing Power of Attorney is still in full force and effect on the date of this certificate; and I do further certify that Article V, Section 8, of the By-Laws of the Companies is still in force.

This Power of Attorney and Certificate may be signed by facsimile under and by authority of the following resolution of the Board of Directors of the ZURICH AMERICAN INSURANCE COMPANY at a meeting duly called and held on the 15th day of December 1998.

RESOLVED: "That the signature of the President or a Vice President and the attesting signature of a Secretary or an Assistant Secretary and the Seal of the Company may be affixed by facsimile on any Power of Attorney...Any such Power or any certificate thereof bearing such facsimile signature and seal shall be valid and binding on the Company."

This Power of Attorney and Certificate may be signed by facsimile under and by authority of the following resolution of the Board of Directors of the COLONIAL AMERICAN CASUALTY AND SURETY COMPANY at a meeting duly called and held on the 5th day of May, 1994, and the following resolution of the Board of Directors of the FIDELITY AND DEPOSIT COMPANY OF MARYLAND at a meeting duly called and held on the 10th day of May, 1990.

RESOLVED: "That the facsimile or mechanically reproduced seal of the company and facsimile or mechanically reproduced signature of any Vice-President, Secretary, or Assistant Secretary of the Company, whether made heretofore or hereafter, wherever appearing upon a certified copy of any power of attorney issued by the Company, shall be valid and binding upon the Company with the same force and effect as though manually affixed.

IN TESTIMONY WHEREOF, I have hereunto subscribed my name and affixed the corporate seals of the said Companies, this 2nd day of February, 2024.



MJ Pethick

By: Mary Jean Pethick
Vice President

TO REPORT A CLAIM WITH REGARD TO A SURETY BOND, PLEASE SUBMIT A COMPLETE DESCRIPTION OF THE CLAIM INCLUDING THE PRINCIPAL ON THE BOND, THE BOND NUMBER, AND YOUR CONTACT INFORMATION TO:

Zurich Surety Claims
1299 Zurich Way
Schaumburg, IL 60196-1056
800-626-4577

If your jurisdiction allows for electronic reporting of surety claims, please submit to: reportsfclaims@zurichna.com

Authenticity of this bond can be confirmed at bondvalidator.zurichna.com or 410-559-8790

ZURICH AMERICAN INSURANCE COMPANY
COLONIAL AMERICAN CASUALTY AND SURETY COMPANY
FIDELITY AND DEPOSIT COMPANY OF MARYLAND
POWER OF ATTORNEY

KNOW ALL MEN BY THESE PRESENTS: That the ZURICH AMERICAN INSURANCE COMPANY, a corporation of the State of New York, the COLONIAL AMERICAN CASUALTY AND SURETY COMPANY, a corporation of the State of Illinois, and the FIDELITY AND DEPOSIT COMPANY OF MARYLAND a corporation of the State of Illinois (herein collectively called the "Companies"), by **Robert D. Murray, Vice President**, in pursuance of authority granted by Article V, Section 8, of the By-Laws of said Companies, which are set forth on the reverse side hereof and are hereby certified to be in full force and effect on the date hereof, do hereby nominate, constitute, and appoint Rebecca Haas-Bates, its true and lawful agent and Attorney-in-Fact, to make, execute, seal and deliver, for, and on its behalf as surety, and as its act and deed: **any and all bonds and undertakings**, and the execution of such bonds or undertakings in pursuance of these presents, shall be as binding upon said Companies, as fully and amply, to all intents and purposes, as if they had been duly executed and acknowledged by the regularly elected officers of the ZURICH AMERICAN INSURANCE COMPANY at its office in New York, New York., the regularly elected officers of the COLONIAL AMERICAN CASUALTY AND SURETY COMPANY at its office in Owings Mills, Maryland., and the regularly elected officers of the FIDELITY AND DEPOSIT COMPANY OF MARYLAND at its office in Owings Mills, Maryland., in their own proper persons.

The said Vice President does hereby certify that the extract set forth on the reverse side hereof is a true copy of Article V, Section 8, of the By-Laws of said Companies, and is now in force.

IN WITNESS WHEREOF, the said Vice-President has hereunto subscribed his/her names and affixed the Corporate Seals of the said **ZURICH AMERICAN INSURANCE COMPANY, COLONIAL AMERICAN CASUALTY AND SURETY COMPANY, and FIDELITY AND DEPOSIT COMPANY OF MARYLAND**, this 2nd day of February, A.D. 2024 .



ATTEST:

ZURICH AMERICAN INSURANCE COMPANY
COLONIAL AMERICAN CASUALTY AND SURETY COMPANY
FIDELITY AND DEPOSIT COMPANY OF MARYLAND

By: *Robert D. Murray*
Vice President

By: *Dawn E. Brown*
Secretary

State of Maryland
County of Baltimore

On this 2nd day of February, A.D. 2024 , before the subscriber, a Notary Public of the State of Maryland, duly commissioned and qualified, **Robert D. Murray, Vice President and Dawn E. Brown, Secretary** of the Companies, to me personally known to be the individuals and officers described in and who executed the preceding instrument, and acknowledged the execution of same, and being by me duly sworn, depose and saith, that he/she is the said officer of the Company aforesaid, and that the seals affixed to the preceding instrument are the Corporate Seals of said Companies, and that the said Corporate Seals and the signature as such officer were duly affixed and subscribed to the said instrument by the authority and direction of the said Corporations.

IN TESTIMONY WHEREOF, I have hereunto set my hand and affixed my Official Seal the day and year first above written.

Genevieve M. Maison

GENEVIEVE M. MAISON
NOTARY PUBLIC
BALTIMORE COUNTY, MD
My Commission Expires JANUARY 27, 2025



- Company Profile
- Company Search
- Company Search Results
- Company Information
- Old Company Names
- Agent for Service Reference Information
- NAIC Group List
- Lines of Business
- Workers' Compensation Complaint and Request for Action/Appeals Contact Information
- Financial Statements PDF's
- Annual Statements
- Quarterly Statements
- Company Complaint
- Company Performance & Comparison Data
- Company Enforcement Action
- Composite Complaints Studies
- Additional Info
- Find A Company Representative In Your Area
- View Financial Disclaimer

COMPANY PROFILE

Company Information

FIDELITY AND DEPOSIT COMPANY OF MARYLAND

**1299 ZURICH WAY
SCHAUMBURG, IL 60196
800-382-2150**

Old Company Names

Effective Date

Agent For Service

Melissa DeKoven
2710 Gateway Oaks Drive, Suite 150N
Sacramento CA 95833-3505

Reference Information

NAIC #:	39306
California Company ID #:	2479-4
Date Authorized in California:	01/01/1982
License Status:	UNLIMITED-NORMAL
Company Type:	Property & Casualty
State of Domicile:	ILLINOIS

[back to top](#)

NAIC Group List

NAIC Group #: 0212 ZURICH INS GRP

Lines Of Business

The company is authorized to transact business within these lines of insurance. For an explanation of any of these terms, please refer to the [glossary](#).

- AIRCRAFT
- AUTOMOBILE
- BOILER AND MACHINERY
- BURGLARY
- CREDIT
- FIRE
- LIABILITY
- MARINE
- MISCELLANEOUS
- PLATE GLASS
- SPRINKLER
- SURETY
- TEAM AND VEHICLE
- WORKERS' COMPENSATION



CERTIFICATE OF LIABILITY INSURANCE

DATE (MM/DD/YYYY)

2/23/2024

THIS CERTIFICATE IS ISSUED AS A MATTER OF INFORMATION ONLY AND CONFERS NO RIGHTS UPON THE CERTIFICATE HOLDER. THIS CERTIFICATE DOES NOT AFFIRMATIVELY OR NEGATIVELY AMEND, EXTEND OR ALTER THE COVERAGE AFFORDED BY THE POLICIES BELOW. THIS CERTIFICATE OF INSURANCE DOES NOT CONSTITUTE A CONTRACT BETWEEN THE ISSUING INSURER(S), AUTHORIZED REPRESENTATIVE OR PRODUCER, AND THE CERTIFICATE HOLDER.

IMPORTANT: If the certificate holder is an ADDITIONAL INSURED, the policy(ies) must have ADDITIONAL INSURED provisions or be endorsed. If SUBROGATION IS WAIVED, subject to the terms and conditions of the policy, certain policies may require an endorsement. A statement on this certificate does not confer rights to the certificate holder in lieu of such endorsement(s).

PRODUCER Edgewood Partners Insurance Center P.O. Box 5003 San Ramon, CA 94583 www.epicbrokers.com CA LICENSE #0B29370		CONTACT NAME: Certificates Department PHONE (A/C, No, Ext): 559-451-3200 FAX (A/C, No): 925-901-0671 E-MAIL ADDRESS: EPICcerts@epicbrokers.com															
INSURED All American Asphalt P.O. Box 2229 Corona CA 92878		<table border="1"> <thead> <tr> <th>INSURER(S) AFFORDING COVERAGE</th> <th>NAIC #</th> </tr> </thead> <tbody> <tr> <td>INSURER A : Arch Specialty Insurance Company</td> <td>21199</td> </tr> <tr> <td>INSURER B : Zurich American Insurance Company</td> <td>16535</td> </tr> <tr> <td>INSURER C : Great American Insurance Company</td> <td>16691</td> </tr> <tr> <td>INSURER D :</td> <td></td> </tr> <tr> <td>INSURER E :</td> <td></td> </tr> <tr> <td>INSURER F :</td> <td></td> </tr> </tbody> </table>		INSURER(S) AFFORDING COVERAGE	NAIC #	INSURER A : Arch Specialty Insurance Company	21199	INSURER B : Zurich American Insurance Company	16535	INSURER C : Great American Insurance Company	16691	INSURER D :		INSURER E :		INSURER F :	
INSURER(S) AFFORDING COVERAGE	NAIC #																
INSURER A : Arch Specialty Insurance Company	21199																
INSURER B : Zurich American Insurance Company	16535																
INSURER C : Great American Insurance Company	16691																
INSURER D :																	
INSURER E :																	
INSURER F :																	

COVERAGES

CERTIFICATE NUMBER: 78795180

REVISION NUMBER:

THIS IS TO CERTIFY THAT THE POLICIES OF INSURANCE LISTED BELOW HAVE BEEN ISSUED TO THE INSURED NAMED ABOVE FOR THE POLICY PERIOD INDICATED. NOTWITHSTANDING ANY REQUIREMENT, TERM OR CONDITION OF ANY CONTRACT OR OTHER DOCUMENT WITH RESPECT TO WHICH THIS CERTIFICATE MAY BE ISSUED OR MAY PERTAIN, THE INSURANCE AFFORDED BY THE POLICIES DESCRIBED HEREIN IS SUBJECT TO ALL THE TERMS, EXCLUSIONS AND CONDITIONS OF SUCH POLICIES. LIMITS SHOWN MAY HAVE BEEN REDUCED BY PAID CLAIMS.

INSR LTR	TYPE OF INSURANCE	ADDL INSD	SUBR WVP	POLICY NUMBER	POLICY EFF (MM/DD/YYYY)	POLICY EXP (MM/DD/YYYY)	LIMITS
A	<input checked="" type="checkbox"/> COMMERCIAL GENERAL LIABILITY <input type="checkbox"/> CLAIMS-MADE <input checked="" type="checkbox"/> OCCUR GEN'L AGGREGATE LIMIT APPLIES PER: <input type="checkbox"/> POLICY <input checked="" type="checkbox"/> PRO-JECT <input type="checkbox"/> LOC <input type="checkbox"/> OTHER:			DPC100585607	8/1/2023	8/1/2024	EACH OCCURRENCE \$ 1,000,000 DAMAGE TO RENTED PREMISES (Ea occurrence) \$ 100,000 MED EXP (Any one person) \$ PERSONAL & ADV INJURY \$ 1,000,000 GENERAL AGGREGATE \$ 2,000,000 PRODUCTS - COMP/OP AGG \$ 2,000,000 \$
B	AUTOMOBILE LIABILITY <input checked="" type="checkbox"/> ANY AUTO <input type="checkbox"/> OWNED AUTOS ONLY <input type="checkbox"/> SCHEDULED AUTOS <input checked="" type="checkbox"/> HIRED AUTOS ONLY <input checked="" type="checkbox"/> NON-OWNED AUTOS ONLY			BAP557108811	8/1/2023	8/1/2024	COMBINED SINGLE LIMIT (Ea accident) \$ 2,000,000 BODILY INJURY (Per person) \$ BODILY INJURY (Per accident) \$ PROPERTY DAMAGE (Per accident) \$ \$
C	<input type="checkbox"/> UMBRELLA LIAB <input checked="" type="checkbox"/> OCCUR <input checked="" type="checkbox"/> EXCESS LIAB <input type="checkbox"/> CLAIMS-MADE <input type="checkbox"/> DED <input checked="" type="checkbox"/> RETENTION \$ 10,000			TUE347483603	8/1/2023	8/1/2024	EACH OCCURRENCE \$ 5,000,000 AGGREGATE \$ 5,000,000 Following-Form \$
B	WORKERS COMPENSATION AND EMPLOYERS' LIABILITY ANY PROPRIETOR/PARTNER/EXECUTIVE OFFICER/MEMBER EXCLUDED? (Mandatory in NH) If yes, describe under DESCRIPTION OF OPERATIONS below	Y/N	N/A	WC593205710	8/1/2023	8/1/2024	<input checked="" type="checkbox"/> PER STATUTE <input type="checkbox"/> OTH-ER E.L. EACH ACCIDENT \$ 1,000,000 E.L. DISEASE - EA EMPLOYEE \$ 1,000,000 E.L. DISEASE - POLICY LIMIT \$ 1,000,000

DESCRIPTION OF OPERATIONS / LOCATIONS / VEHICLES (ACORD 101, Additional Remarks Schedule, may be attached if more space is required)

#35864 / Project #D2-0049 / RE: Lakepointe Drive Reconstruction Indiana Avenue to Southern Sun Summit Drive Community of Lake Hills / City of Riverside, their respective director, officers, Board of Supervisors, elected and appointed officials, employees, agents, and representatives. Western Municipal Water District, their respective director, officers, Board of Supervisors, elected and appointed officials, employees, agents, and representatives.
 Certificate Holder is Additional Insured if Required by Written Contract Excluding Workers Compensation

CERTIFICATE HOLDER

County of Riverside Transportation Department
 3525 14th Street
 Riverside CA 92501

CANCELLATION

SHOULD ANY OF THE ABOVE DESCRIBED POLICIES BE CANCELLED BEFORE THE EXPIRATION DATE THEREOF, NOTICE WILL BE DELIVERED IN ACCORDANCE WITH THE POLICY PROVISIONS.

AUTHORIZED REPRESENTATIVE

Maleah Cantrell

© 1988-2015 ACORD CORPORATION. All rights reserved.

ACORD 25 (2016/03)

The ACORD name and logo are registered marks of ACORD



PO Box 5003
San Ramon, CA 94583
Phone: 925.244.7700
Fax: 925.901-0244
Email: EPICcerts@epicbrokers.com

CERTIFICATE HOLDER:

County of Riverside Transportation Department
3525 14th Street
Riverside CA 92501

To: Whom it may concern

Regarding: Notice of Cancellation

Date Issued: 2/23/2024

Named Insured(s): All American Asphalt

Policy Number(s): DPC100585607
BAP557108811
WC593205710
TUE347483603

Should the above described policy be cancelled before the expiration date thereof, we will mail 30 days written notice to the above referenced Certificate Holder; except, 10 days notice for non-payment of premium.

Sincerely,

Maleah Cantrell

THIS ENDORSEMENT CHANGES THE POLICY. PLEASE READ IT CAREFULLY.

ADDITIONAL INSURED – OWNERS, LESSEES OR CONTRACTORS – SCHEDULED PERSON OR ORGANIZATION

This endorsement modifies insurance provided under the following:

COMMERCIAL GENERAL LIABILITY COVERAGE PART

SCHEDULE

Name Of Additional Insured Person(s) Or Organization(s):	Location(s) Of Covered Operations
Any person or organization where the Named Insured has agreed to add as an additional insured by written contract or agreement, provided the contract or agreement is executed prior to any "occurrence" or offense	Any location where required by written contract or agreement, provided the contract or agreement is executed prior to any "occurrence" or offense.
Information required to complete this Schedule, if not shown above, will be shown in the Declarations.	

A. Section II – Who Is An Insured is amended to include as an additional insured the person(s) or organization(s) shown in the Schedule, but only with respect to liability for "bodily injury", "property damage" or "personal and advertising injury" caused, in whole or in part, by:

1. Your acts or omissions; or
2. The acts or omissions of those acting on your behalf;

in the performance of your ongoing operations for the additional insured(s) at the location(s) designated above.

However:

1. The insurance afforded to such additional insured only applies to the extent permitted by law; and
2. If coverage provided to the additional insured is required by a contract or agreement, the insurance afforded to such additional insured will not be

broader than that which you are required by the contract or agreement to provide for such additional insured.

B. With respect to the insurance afforded to these additional insureds, the following additional exclusions apply:

This insurance does not apply to "bodily injury" or "property damage" occurring after:

1. All work, including materials, parts or equipment furnished in connection with such work, on the project (other than service, maintenance or repairs) to be performed by or on behalf of the additional insured(s) at the location of the covered operations has been completed; or
2. That portion of "your work" out of which the injury or damage arises has been put to its intended use by any person or organization other than another contractor or subcontractor engaged in

performing operations for a principal as a part of the same project.

- C. With respect to the insurance afforded to these additional insureds, the following is added to **Section III – Limits Of Insurance**:

If coverage provided to the additional insured is required by a contract or agreement, the most we will pay on behalf of the additional insured is the amount of insurance:

All other terms and conditions of this policy remain unchanged.

Endorsement Number:

This endorsement is effective on the inception date of this policy unless otherwise stated herein.

(The information below is required only when this endorsement is issued subsequent to preparation of the policy.)

Policy Number: DPC100585607

Named Insured: All American Asphalt

Endorsement Effective Date: 08/01/2023

1. Required by the contract or agreement; or

2. Available under the applicable Limits of Insurance shown in the Declarations;

whichever is less.

This endorsement shall not increase the applicable Limits of Insurance shown in the Declarations.

REFERENCE:

#35864 / Project #D2-0049 / RE: Lakepointe Drive Reconstruction Indiana Avenue to Southern Sun Summit Drive Community of Lake Hills /

City of Riverside, their respective director, officers, Board of Supervisors, elected and appointed officials, employees, agents, and representatives.

Western Municipal Water District, their respective director, officers, Board of Supervisors, elected and appointed officials, employees, agents, and

SCHEDULE:

City of Riverside, their respective director, officers, Board of Supervisors, elected and appointed officials, employees, agents, and representatives. Western Municipal Water District, their respective director, officers, Board of Supervisors, elected and appointed officials, employees, agents, and representatives.



THIS ENDORSEMENT CHANGES THE POLICY. PLEASE READ IT CAREFULLY.

ADDITIONAL INSURED – OWNERS, LESSEES OR CONTRACTORS – COMPLETED OPERATIONS

This endorsement modifies insurance provided under the following:

COMMERCIAL GENERAL LIABILITY COVERAGE PART
PRODUCTS/COMPLETED OPERATIONS LIABILITY COVERAGE PART

SCHEDULE

Name Of Additional Insured Person(s) Or Organization(s)	Location And Description Of Completed Operations
Any person or organization where the Named Insured has agreed to add as an additional insured by written contract or agreement, provided the contract or agreement is executed prior to any "occurrence" or offense	All locations where required by contract.
Information required to complete this Schedule, if not shown above, will be shown in the Declarations.	

A. Section II – Who Is An Insured is amended to include as an additional insured the person(s) or organization(s) shown in the Schedule, but only with respect to liability for "bodily injury" or "property damage" caused, in whole or in part, by "your work" at the location designated and described in the Schedule of this endorsement performed for that additional insured and included in the "products-completed operations hazard".

However:

1. The insurance afforded to such additional insured only applies to the extent permitted by law; and
2. If coverage provided to the additional insured is required by a contract or agreement, the insurance afforded to such additional insured will not be broader than that which you are required by the contract or agreement to provide for such

additional insured.

B. With respect to the insurance afforded to these additional insureds, the following is added to **Section III – Limits Of Insurance**:

If coverage provided to the additional insured is required by a contract or agreement, the most we will pay on behalf of the additional insured is the amount of insurance:

1. Required by the contract or agreement; or
2. Available under the applicable Limits of Insurance shown in the Declarations;

whichever is less.

This endorsement shall not increase the applicable Limits of Insurance shown in the Declarations.

All other terms and conditions of this Policy remain unchanged.

Endorsement Number:

This endorsement is effective on the inception date of this policy unless otherwise stated herein.

(The information below is required only when this endorsement is issued subsequent to preparation of the policy.)

Policy Number: DPC100585607

Named Insured: All American Asphalt

Endorsement Effective Date: 08/01/2023

REFERENCE:

#35864 / Project #D2-0049 / RE: Lakepointe Drive Reconstruction
Indiana Avenue to Southern Sun Summit Drive Community of Lake
Hills /

City of Riverside, their respective director, officers, Board of
Supervisors, elected and appointed officials, employees, agents, and
representatives.

Western Municipal Water District, their respective director, officers,
Board of Supervisors, elected and appointed officials, employees,
agents, and

SCHEDULE:

City of Riverside, their respective director, officers, Board of
Supervisors, elected and appointed officials, employees, agents, and
representatives. Western Municipal Water District, their respective
director, officers, Board of Supervisors, elected and appointed officials,
employees, agents, and representatives.

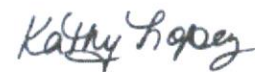

THIS ENDORSEMENT CHANGES THE POLICY. PLEASE READ IT CAREFULLY.

PRIMARY AND NONCONTRIBUTORY – OTHER INSURANCE CONDITION

This endorsement modifies insurance provided under the following:

COMMERCIAL GENERAL LIABILITY COVERAGE PART
PRODUCTS/COMPLETED OPERATIONS LIABILITY COVERAGE PART

The following is added to the **Other Insurance** Condition and supersedes any provision to the contrary:

Primary And Noncontributory Insurance

This insurance is primary to and will not seek contribution from any other insurance available to an additional insured under your policy provided that:

- (1) The additional insured is a Named Insured under such other insurance; and
- (2) You have agreed in writing in a contract or agreement that this insurance would be primary and would not seek contribution from any other insurance available to the additional insured.

All other terms and conditions of this policy remain unchanged.

REFERENCE:

#35864 / Project #D2-0049 / RE: Lakepointe Drive Reconstruction Indiana Avenue to Southern Sun Summit Drive Community of Lake Hills /

City of Riverside, their respective director, officers, Board of Supervisors, elected and appointed officials, employees, agents, and representatives.

Western Municipal Water District, their respective director, officers, Board of Supervisors, elected and appointed officials, employees, agents, and

SCHEDULE:

City of Riverside, their respective director, officers, Board of Supervisors, elected and appointed officials, employees, agents, and representatives. Western Municipal Water District, their respective director, officers, Board of Supervisors, elected and appointed officials, employees, agents, and representatives.

Endorsement Number:

This endorsement is effective on the inception date of this policy unless otherwise stated herein.

(The information below is required only when this endorsement is issued subsequent to preparation of the policy.)

Policy Number: DPC100585607

Named Insured: All American Asphalt

Endorsement Effective Date: 08/01/2023

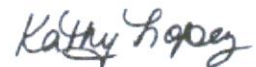

THIS ENDORSEMENT CHANGES THE POLICY. PLEASE READ IT CAREFULLY.

WAIVER OF TRANSFER OF RIGHTS OF RECOVERY AGAINST OTHERS TO US

This endorsement modifies insurance provided under the following:

COMMERCIAL GENERAL LIABILITY COVERAGE PART
PRODUCTS/COMPLETED OPERATIONS LIABILITY COVERAGE PART

SCHEDULE

Name Of Person Or Organization:

Any person or organization where the waiver of our right to recover is permitted by law and is required by written contract or agreement, provided the contract or agreement is executed prior to any occurrence or offense

Information required to complete this Schedule, if not shown above, will be shown in the Declarations.

The following is added to Paragraph 8. **Transfer Of Rights Of Recovery Against Others To Us of Section IV – Conditions:**

We waive any right of recovery we may have against the person or organization shown in the Schedule above because of payments we make. All other terms and conditions of this policy remain unchanged.

Endorsement Number:

This endorsement is effective on the inception date of this policy unless otherwise stated herein.

(The information below is required only when this endorsement is issued subsequent to preparation of the policy.)

Policy Number: DPC100585607

Named Insured: All American Asphalt

Endorsement Effective Date: 08/01/2023

for injury or damage arising out of your ongoing operations or "your work" done under a contract with that person or organization and included in the "products-completed operations hazard". This waiver applies only to the person or organization shown in the Schedule above.

REFERENCE:

#35864 / Project #D2-0049 / RE: Lakepointe Drive Reconstruction Indiana Avenue to Southern Sun Summit Drive Community of Lake Hills /

City of Riverside, their respective director, officers, Board of Supervisors, elected and appointed officials, employees, agents, and representatives.

Western Municipal Water District, their respective director, officers, Board of Supervisors, elected and appointed officials, employees, agents, and

SCHEDULE:

City of Riverside, their respective director, officers, Board of Supervisors, elected and appointed officials, employees, agents, and representatives. Western Municipal Water District, their respective director, officers, Board of Supervisors, elected and appointed officials, employees, agents, and representatives.



POLICY NUMBER: BAP557108811

COMMERCIAL AUTO
CA 20 48 10 13

THIS ENDORSEMENT CHANGES THE POLICY. PLEASE READ IT CAREFULLY.

DESIGNATED INSURED FOR COVERED AUTOS LIABILITY COVERAGE

This endorsement modifies insurance provided under the following:

AUTO DEALERS COVERAGE FORM
BUSINESS AUTO COVERAGE FORM
MOTOR CARRIER COVERAGE FORM

With respect to coverage provided by this endorsement, the provisions of the Coverage Form apply unless modified by this endorsement.

This endorsement identifies person(s) or organization(s) who are "insureds" for Covered Autos Liability Coverage under the Who Is An Insured provision of the Coverage Form. This endorsement does not alter coverage provided in the Coverage Form.

This endorsement changes the policy effective on the inception date of the policy unless another date is indicated below.

<p>Named Insured: All American Asphalt</p> <p>Endorsement Effective Date: 08/01/2023</p>
--

SCHEDULE

<p>Name Of Person(s) Or Organization(s): ANY PERSON OR ORGANIZATION TO WHOM OR WHICH YOU ARE REQUIRED TO PROVIDE ADDITIONAL INSURED STATUS ON A PRIMARY, NON-CONTRIBUTORY BASIS, IN A WRITTEN CONTRACT OR WRITTEN AGREEMENT EXECUTED PRIOR TO LOSS, EXCEPT WHERE SUCH CONTRACT OR AGREEMENT IS PROHIBITED BY LAW.</p>
<p>Information required to complete this Schedule, if not shown above, will be shown in the Declarations.</p>

Each person or organization shown in the Schedule is an "insured" for Covered Autos Liability Coverage, but only to the extent that person or organization qualifies as an "insured" under the Who Is An Insured provision contained in Paragraph **A.1.** of Section **II** - Covered Autos Liability Coverage in the Business Auto and Motor Carrier Coverage Forms and Paragraph **D.2.** of Section **I** - Covered Autos Coverages of the Auto Dealers Coverage Form.

SCHEDULE:

City of Riverside, their respective director, officers, Board of Supervisors, elected and appointed officials, employees, agents, and representatives. Western Municipal Water District, their respective director, officers, Board of Supervisors, elected and appointed officials, employees, agents, and representatives.

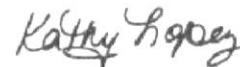

THIS ENDORSEMENT CHANGES THE POLICY. PLEASE READ IT CAREFULLY.

**WAIVER OF TRANSFER OF RIGHTS OF RECOVERY
AGAINST OTHERS TO US (WAIVER OF SUBROGATION)**

This endorsement modifies insurance provided under the following:

- AUTO DEALERS COVERAGE FORM
- BUSINESS AUTO COVERAGE FORM
- MOTOR CARRIER COVERAGE FORM

With respect to coverage provided by this endorsement, the provisions of the Coverage Form apply unless modified by the endorsement.

This endorsement changes the policy effective on the inception date of the policy unless another date is indicated below.

Named Insured: All American Asphalt

Endorsement Effective Date: 08/01/2023

SCHEDULE

Name(s) Of Person(s) Or Organization(s):

ALL PERSONS AND/OR ORGANIZATIONS THAT ARE REQUIRED BY WRITTEN CONTRACT OR AGREEMENT WITH THE INSURED, EXECUTED PRIOR TO THE ACCIDENT OR LOSS, THAT WAIVER OF SUBROGATION BE PROVIDED UNDER THIS POLICY

Information required to complete this Schedule, if not shown above, will be shown in the Declarations.

The **Transfer Of Rights Of Recovery Against Others To Us** condition does not apply to the person(s) or organization(s) shown in the Schedule, but only to the extent that subrogation is waived prior to the "accident" or the "loss" under a contract with that person or organization.

SCHEDULE:

City of Riverside, their respective director, officers, Board of Supervisors, elected and appointed officials, employees, agents, and representatives. Western Municipal Water District, their respective director, officers, Board of Supervisors, elected and appointed officials, employees, agents, and representatives.

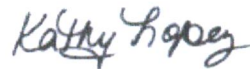

WAIVER OF OUR RIGHT TO RECOVER FROM OTHERS ENDORSEMENT— CALIFORNIA

We have the right to recover our payments from anyone liable for an injury covered by this policy. We will not enforce our right against the person or organization named in the Schedule. (This agreement applies only to the extent that you perform work under a written contract that requires you to obtain this agreement from us.)

You must maintain payroll records accurately segregating the remuneration of your employees while engaged in the work described in the Schedule.

The additional premium for this endorsement shall be 0.00 % of the California workers' compensation premium otherwise due on such remuneration.

Schedule

Person or Organization

ALL PERSONS AND/OR ORGANIZATIONS THAT ARE REQUIRED BY WRITTEN CONTRACT OR AGREEMENT WITH THE INSURED, EXECUTED PRIOR TO THE ACCIDENT OR LOSS, THAT WAIVER OF SUBROGATION BE PROVIDED UNDER THIS POLICY FOR WORK PERFORMED BY YOU FOR THAT PERSON AND/OR ORGANIZATION

Job Description

ALL CA OPERATIONS

SCHEDULE:

City of Riverside, their respective director, officers, Board of Supervisors, elected and appointed officials, employees, agents, and representatives. Western Municipal Water District, their respective director, officers, Board of Supervisors, elected and appointed officials, employees, agents, and representatives.

REFERENCE:

#35864 / Project #D2-0049 / RE: Lakepointe Drive Reconstruction Indiana Avenue to Southern Sun Summit Drive Community of Lake Hills / City of Riverside, their respective director, officers, Board of Supervisors, elected and appointed officials, employees, agents, and representatives.

Western Municipal Water District, their respective director, officers, Board of Supervisors, elected and appointed officials, employees, agents, and

Policy Number: WC593205710

Named Insured: All American Asphalt

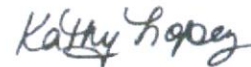

Endorsement Effective Date: 08/01/2023

205737

TAU 9501 (Ed. 11 97)

Policy No. TUE 3474836 - 03
Renewal Of TUE 3474836 - 02

EXCESS LIABILITY POLICY DECLARATIONS

ITEM 1. NAMED INSURED AND MAILING ADDRESS:

ALL AMERICAN ASPHALT
P.O. BOX 2229
CORONA, CA 92878

ITEM 2. POLICY PERIOD:

12:01 A.M. Standard Time at the
mailing address of the Named
Insured shown at left.
From 08/01/2023 To 08/01/2024

**IN RETURN FOR PAYMENT OF THE PREMIUM,
AND SUBJECT TO ALL TERMS OF THIS
POLICY, WE AGREE WITH YOU TO PROVIDE
THE INSURANCE AS STATED IN THIS
POLICY.**

AGENT'S NAME AND ADDRESS:

EDGEWOOD PARTNERS INSURANCE CENTER
3633 INLAND EMPIRE BOULEVARD
SUITE 640
ONTARIO, CA 91764

Insurance is Afforded by Company indicated below:
GREAT AMERICAN INSURANCE COMPANY
(A capital stock corporation)

ITEM 3. POLICY PREMIUM:

PREMIUM BASIS: (X) Flat () Auditable

**POLICY MINIMUM
PREMIUM:**

ITEM 4. LIMITS OF INSURANCE:

The Company's Liability under this policy will not exceed the
following limit: 100 percent of "loss" excess of Underlying
Insurance stated in **Item 5.** of the Declarations, but for no
greater than:
\$ 10,000,000. Each Occurrence
\$ 10,000,000. Aggregate Limit (where applicable)

ITEM 5. SCHEDULE OF UNDERLYING INSURANCE:

First Underlying Insurance Policy
Insurer, Policy No., Policy Period
SEE ATTACHED GAI6003 SCHEDULE A-
SCHEDULE OF UNDERLYING POLICIES

Applicable Limit
\$ GAI6003 Each Occurrence
\$ GAI6003 Aggregate Limit
(where applicable)

**Other Underlying Insurance (Excess
of First Underlying Insurance Policy)**
N/A

Applicable Limit
\$ N/A Each Occurrence
\$ N/A Aggregate Limit
(where applicable)

ITEM 6. FORMS AND ENDORSEMENTS applicable to all Coverage Forms and made part
of this policy at time of issue are listed on the attached Forms and
Endorsements Schedule, TAU 9997 (Ed. 11/97).

Countersigned _____ By _____
Date



Authorized Representative

*Kathy Lopez*TAU 9500
(Ed. 11 97)**EXCESS LIABILITY POLICY**

There are provisions in this policy that restrict coverage. Read the entire policy carefully to determine rights, duties and what is and is not covered.

Words and phrases in quotation marks have special meaning and can be found in the **Definitions** Section or the specific policy provision where they appear.

In consideration of the payment of the premium and in reliance upon the statements in the Declarations we agree with you to provide coverage as follows:

INSURING AGREEMENTS**I. COVERAGE**

We will pay on behalf of the Insured "loss" in excess of the Underlying Limits of Insurance shown in Item 5. of the Declarations, but only up to an amount not exceeding the Company's Limits of Insurance as shown in Item 4. of the Declarations. Except for the terms, conditions, definitions and exclusions of this policy, the coverage provided by this policy will follow the First Underlying Insurance Policy, as shown in Item 5. of the Declarations.

The inclusion or addition hereunder of more than one Insured shall not operate to increase the Company's Limits of Insurance beyond that set forth in Item 4. of the Declarations.

We will be furnished a complete copy of the First Underlying Insurance Policy described in Item 5. of the Declarations.

II. LIMITS OF INSURANCE

A. The Limits of Insurance shown in the Declarations and the rules below describe the most we will pay regardless of the number of:

1. Insureds;
2. claims made or suits brought; or
3. Persons or organizations making claims or bringing suits.

B. The Limits of Insurance of this policy will apply as follows:

1. This policy applies only in excess of the Underlying Limits of Insurance shown in Item 5. of the Declarations.
2. The aggregate limit shown in Item 4. of the Declarations is the most we will pay for all "loss" that is subject to an aggregate limit provided by the First Underlying Insurance Policy. The aggregate limit applies separately and in the same manner as the aggregate limits provided by the First Underlying Insurance Policy.
3. Subject to **B.2.**, the occurrence limit stated in Item 4. of the Declarations is the most we will pay for all "loss" arising out of any one occurrence to which this policy applies.
4. Subject to Paragraphs **B.2.** and **B.3.** above, if the underlying Limits of Insurance stated in Item 5. of the Declarations are reduced or exhausted solely by payment of "loss," such insurance provided by this policy will apply in excess of the reduced Underlying Limits or, if all Underlying Limits are exhausted, will apply as underlying insurance subject to the same terms, conditions, definitions and exclusions of the First Underlying Insurance Policy, except for the terms, conditions, definitions and exclusions of this policy.
5. The Limits of Insurance of this policy apply separately to each consecutive annual period and to any remaining pe-

SCHEDULE A - SCHEDULE OF UNDERLYING INSURANCE

Carrier, Policy Number and Period	Type of Coverage	Limits of Insurance
a) ZURICH AMERICAN INSURANCE COMPANY POL: WC5932057-10 8/1/23 TO 8/1/24	Employers Liability	Bodily Injury By Accident \$ 1,000,000. each accident Bodily Injury By Disease \$ 1,000,000. policy limit \$ 1,000,000. each employee
b) ZURICH AMERICAN INSURANCE COMPANY POL: BAP5571088-11 8/1/23 TO 8/1/24	Automobile/Garage <input checked="" type="checkbox"/> Any Automobile <input type="checkbox"/> Owned Automobile Only <input type="checkbox"/> Specifically Designated Automobile <input type="checkbox"/> Hired Automobile <input type="checkbox"/> Non-owned Automobile <input type="checkbox"/> Garage Liability <input checked="" type="checkbox"/> DEFENSE OUTSIDE THE LIMIT	<input type="checkbox"/> Split Limit Bodily Injury Liability \$ each person \$ each accident Property Damage Liability \$ each accident <input checked="" type="checkbox"/> Combined Single Limit \$ 2,000,000. each accident <input type="checkbox"/> Garage Operations \$ Auto only each accident \$ Other than auto each accident \$ Other than auto aggregate
	<input type="checkbox"/> Garagekeepers Liability	\$ each location

Carrier, Policy Number and Period	Type of Coverage	Limits of Insurance
<p>c) ()</p> <p style="text-align: center;">OR</p> <p>(X) ARCH SPECIALTY INSURANCE COMPANY POL: DCPC1005856-07 8/1/23 TO 8/1/24 EXCESS OF \$150,000 SIR/AGG APPLIED TO THE SIR-\$1MM</p> <p>(X) DEFENSE OUTSIDE THE LIMIT</p> <p>Retroactive Date</p>	<p>Comprehensive General Liability including</p> <p>() Products-Comple- ted Operation Liability</p> <p>() Broad Form Endorsement</p> <p>()</p> <p>()</p> <p style="text-align: center;">OR</p> <p>Commercial General Liability</p> <p>() Occurrence Form</p> <p>() Claims-Made Form</p> <p>(X) GENERAL AGGREGATE APPLIES PER PROJECT</p>	<p>() Split Limit</p> <p>Bodily Injury Liability</p> <p>\$ each occurrence</p> <p>\$ aggregate</p> <p>Property Damage Liability</p> <p>\$ each occurrence</p> <p>\$ aggregate</p> <p>() Combined Single Limit</p> <p>\$ each occurrence</p> <p>\$ aggregate</p> <p style="text-align: center;">OR</p> <p>\$2,000,000. General Aggre- gate Limit</p> <p>\$2,000,000. Products-Com- pleted Opera- tion Aggre- gate Limit</p> <p>\$1,000,000. Personal and Advertising Injury Limit</p> <p>\$1,000,000. Each Occurrence Limit</p>
<p>d) ARCH SPECIALTY INSURANCE COMPANY POL: DCPC1005856-07 8/1/23 TO 8/1/24</p>	<p>EMPLOYEE BENEFIT LIABILITY</p>	<p>\$1,000,000. EACH EMPLOYEE</p> <p>\$1,000,000. AGGREGATE LIMIT</p>

Kathy Lopez

List of Approved Surplus Line Insurers (LASLI)

Please use the "Find" option in the "Edit" menu of your browser to search for a particular company.

List is current as of: December 21, 2023

[A](#) | [B-D](#) | [E-G](#) | [H-L](#) | [M-P](#) | [Q-Z](#)

A

Insurer	Date Approved
Acceptance Casualty Insurance Company (Nebraska)	10/23/2007
Accident Fund General Insurance Company (Michigan)	11/19/2020
Admiral Insurance Company (Delaware)	06/30/1995
Adriatic Insurance Company (North Dakota)	06/30/1995
AIG Specialty Insurance Company (Illinois) (Name changed from Chartis Specialty Insurance Company effective 10/01/2013)	06/30/1995
AIX Specialty Insurance Company (Delaware)	06/05/2009
Allianz Global Corporate & Specialty SE (Germany) (Name Changed from Allianz Global Corporate Specialty AG effective 11/13/2013)	06/16/2004
Allied World National Assurance Company (New Hampshire) (Name changed from Newmarket Underwriters Insurance Company effective 10/03/2007)	12/18/1997
Allied World Surplus Lines Insurance Company (Arkansas) (Name changed from Darwin Select Insurance Company effective 06/03/2014) (Name changed from ULICO Indemnity Company Effective 05/13/2010)	12/22/1995
American Inter-Fidelity Exchange (Indiana)	04/18/2023
American Western Home Insurance Company (Oklahoma)	09/01/1995
Arch Insurance (UK) Limited (U.K.) (Name changed from Arch Insurance Company (Europe) Limited effective 03/18/2019)	10/19/2009
Arch Specialty Insurance Company (Missouri) (Name changed from Rock River Insurance Company effective 08/01/2002) (Domicile changed from Nebraska to Missouri effective 09/30/2014)	09/01/1995
Aspen Insurance UK Limited (U.K.)	12/29/2004
Aspen Specialty Insurance Company (North Dakota) (Name changed from Dakota Specialty Insurance Company, effective 10/22/2003)	03/03/1998
Associated Industries Insurance Company, Inc. (Florida)	01/11/2012
Atain Specialty Insurance Company (Michigan) (Name changed from USF Insurance Company effective 08/25/2011) (Domicile changed from Pennsylvania to Michigan effective 12/31/2007)	09/01/1995
Atlantic Casualty Insurance Company (North Carolina)	07/16/2009



- Company Profile
- Company Search
- Company Search Results
- Company Information
- Old Company Names
- Agent for Service Reference Information
- NAIC Group List
- Lines of Business
- Workers' Compensation Complaint and Request for Action/Appeals Contact Information
- Financial Statements PDF's
 - Annual Statements
 - Quarterly Statements
- Company Complaint
 - Company Performance & Comparison Data
 - Company Enforcement Action
 - Composite Complaints Studies
- Additional Info
 - Find A Company Representative In Your Area
 - View Financial Disclaimer

COMPANY PROFILE

Company Information

ZURICH AMERICAN INSURANCE COMPANY

**1299 ZURICH WAY
SCHAUMBURG, IL 60196
800-936-5873**

Old Company Names

Effective Date

Agent For Service

Melissa DeKoven
2710 Gateway Oaks Drive, Suite 150N
Sacramento CA 95833-3505

Reference Information

NAIC #:	16535
California Company ID #:	4581-5
Date Authorized in California:	01/01/1999
License Status:	UNLIMITED-NORMAL
Company Type:	Property & Casualty
State of Domicile:	NEW YORK

[back to top](#)

NAIC Group List

NAIC Group #: **0212** ZURICH INS GRP

Lines Of Business

The company is authorized to transact business within these lines of insurance. For an explanation of any of these terms, please refer to the [glossary](#).

- AIRCRAFT
- AUTOMOBILE
- BOILER AND MACHINERY
- BURGLARY
- COMMON CARRIER LIABILITY
- CREDIT
- DISABILITY
- FIRE
- LIABILITY
- MARINE
- MISCELLANEOUS
- PLATE GLASS
- SPRINKLER
- SURETY
- TEAM AND VEHICLE
- WORKERS' COMPENSATION



- Company Profile
- Company Search
- Company Search Results
- Company Information
- Old Company Names
- Agent for Service Reference Information
- NAIC Group List
- Lines of Business
- Workers' Compensation Complaint and Request for Action/Appeals Contact Information
- Financial Statements PDF's
- Annual Statements
- Quarterly Statements
- Company Complaint
- Company Performance & Comparison Data
- Company Enforcement Action
- Composite Complaints Studies
- Additional Info
- Find A Company Representative In Your Area
- View Financial Disclaimer

COMPANY PROFILE

Company Information

GREAT AMERICAN INSURANCE COMPANY
301 E. FOURTH STREET
CINCINNATI, OH 45202-4201
800-545-4269

Old Company Names	Effective Date
AMERICAN CONTINENTAL INSURANCE COMPANY	12/06/1976
MANUFACTURERS & MERCHANTS INDEMNITY CO.	09/05/1956
SELECTIVE INSURANCE COMPANY	06/15/1972

Agent For Service

SARAH CLEMENS
 5901 W. Century Blvd #750
 Los Angeles CA 90045

Reference Information

NAIC #:	16691
California Company ID #:	1301-1
Date Authorized in California:	10/17/1945
License Status:	UNLIMITED-NORMAL
Company Type:	Property & Casualty
State of Domicile:	OHIO

[back to top](#)

NAIC Group List

NAIC Group #: **0084** American Financial Grp

Lines Of Business

The company is authorized to transact business within these lines of insurance. For an explanation of any of these terms, please refer to the [glossary](#).

- AIRCRAFT
- AUTOMOBILE
- BOILER AND MACHINERY
- BURGLARY
- COMMON CARRIER LIABILITY
- CREDIT
- DISABILITY
- FIRE
- LIABILITY
- MARINE
- MISCELLANEOUS
- PLATE GLASS
- SPRINKLER
- SURETY
- TEAM AND VEHICLE
- WORKERS' COMPENSATION