

SUBMITTAL TO THE BOARD OF SUPERVISORS
COUNTY OF RIVERSIDE, STATE OF CALIFORNIA



ITEM: 3.19
(ID # 24876)

MEETING DATE:
Tuesday, July 02, 2024

FROM : TLMA-TRANSPORTATION AND DEPARTMENT OF ANIMAL SERVICES

SUBJECT: TRANSPORTATION AND LAND MANAGEMENT AGENCY/TRANSPORTATION:
Emergency Road and Storm Drain Damage Repair Work, Pedley Road, Emergency Access
Road, Western Riverside County/City Animal Shelter, California Environmental Quality Act
(CEQA) Statutorily and Categorically Exempt. District 2. [\$340,000 Total Cost – General Fund
Contingency 100%] (4/5 Vote Required)

RECOMMENDED MOTION: That the Board of Supervisors:

1. Find that the Emergency Road and Storm Drain Damage Repair Work, Pedley Road, Emergency Access Road, Western Riverside County/City Animal Shelter is exempt from the provisions of California Environmental Quality Act (CEQA) pursuant to Sections 15269 (b), (c) and (d) (Statutory Exemption for Emergency Projects) and 15301 (c) (Existing Facilities);
2. Receive and file an emergency contract, with Riverside Construction Company, Inc., that the Transportation Department has entered into on behalf of the County of Riverside; and
3. Approve and direct the Auditor-Controller to make the budget adjustments shown on Schedule "A".

ACTION: 4/5 Vote Required, Policy

Dennis Acuna, Director of Transportation 5/16/2024

MINUTES OF THE BOARD OF SUPERVISORS

On motion of Supervisor Spiegel, seconded by Supervisor Perez and duly carried by unanimous vote, IT WAS ORDERED that the above matter is approved as recommended.

Ayes: Jeffries, Spiegel, Washington, Perez and Gutierrez
Nays: None
Absent: None
Date: July 2, 2024
xc: Trans., RCDAS

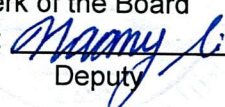
Kimberly A. Rector
Clerk of the Board
By: 
Deputy

**SUBMITTAL TO THE BOARD OF SUPERVISORS COUNTY OF RIVERSIDE,
STATE OF CALIFORNIA**

FINANCIAL DATA	Current Fiscal Year:	Next Fiscal Year:	Total Cost:	Ongoing Cost
COST	\$ 340,000	\$ 0	\$ 340,000	\$ 0
NET COUNTY COST	\$ 340,000	\$ 0	\$ 340,000	\$ 0
SOURCE OF FUNDS: General Fund Contingency (100%)			Budget Adjustment: Yes	
			For Fiscal Year: 23/24	

C.E.O. RECOMMENDATION: Approve

BACKGROUND:

Summary

The Director of Transportation Department entered into an emergency contract on April 10, 2024, with Riverside Construction Company, Inc. of Riverside, California, for the Emergency Road and Storm Drain Damage Repair Work in the Western Riverside County Animal Shelter (Animal Shelter), in the City of Jurupa Valley.

The Riverside County Department of Animal Services (RCDAS) observed severe damage to the emergency access road that is utilized at its Western Riverside County facility. This emergency access road is also utilized by the County Fire Department (Fire Department). Needing roadway repair evaluation, RCDAS reached out to the Transportation Department to leverage our extensive experience in the repair of roads for assistance.

The Transportation Department and the City of Jurupa Valley performed an inspection of the emergency access road and determined that the emergency access road damage was due to recent and past storms, undermining the storm drain and roadway causing scouring at the storm drain culvert outlet. The access road encountered major erosion including partial roadway collapse that left a large cavity, eroded the side slope, and undermined the portions of the existing reinforced concrete pipes that resulted in collapsed culvert concrete headwall and pipes.

Since the RCDAS shares this roadway with the Fire Department, it was determined that immediate repair of this emergency access roadway was necessary to safeguard the public and resume the ability to provide risk services to the nearby community.

Emergency repair of the emergency access roadway involves several tasks of work, including but not limited to environmental stewardship, removal and proper disposal of debris, damaged drainage structures, excess excavation and unusable materials, roadway excavation, earthwork, replacement of existing concrete reinforced pipes, headwall and slope protection, restoration of roadway pavement and curbs, traffic control and additional associated work as directed by the Engineer.

**SUBMITTAL TO THE BOARD OF SUPERVISORS COUNTY OF RIVERSIDE,
STATE OF CALIFORNIA**

The contract was executed in accordance with authority that the Board has delegated to the Director of Transportation by Resolution No. 2019-035 (January 29, 2019; agenda item 3.24) and has been approved as to legal form by County Counsel.

The Specifications and Contract Documents for this repair work have been approved as to legal form by County Counsel.

The contractor is qualified to perform the repair work, has executed the Contract, and provided bonds and insurance documents that meet the contract's requirements.

Project No's. D4-0135

Environmental Findings

The Project is exempt from the provisions of the California Environmental Quality Act (CEQA) as described below. A Notice of Exemption was filed with the County Clerk on April 19, 2024.

State CEQA Guidelines section 15269, Emergency Projects, allows emergency repairs (b) to a public facility necessary to maintain service essential to the public health, safety, or welfare, (c) specific actions necessary to prevent or mitigate an emergency, and (d) projects undertaken to maintain, repair, or restore an existing road damaged by flood. The proposed activities qualify to be statutorily exempt from CEQA under Section 15269 (b), (c), and (d) because the activities consist of necessary repair of a roadway (damaged by flood) to maintain service essential to the public health and safety.

In addition, State CEQA Guidelines section 15301 (c), Existing Facilities, allows for the repair and maintenance of existing public facilities that involve negligible or no expansion of existing or former use. The proposed activities qualify to be exempt from CEQA under Section 15301 (c) because the activities consist of the repair and maintenance of existing facilities that do not create additional traffic lanes and involve negligible or no expansion of the use of the existing roadways and associated facilities.

Impact on Residents and Businesses

The emergency repair work started on April 15, 2024, and was completed on May 16, 2024.

The emergency access road within the Animal Shelter facility was closed for public safety due to access road conditions. Roadway signage notified travelers of the construction. This portion of the access road remained closed while emergency repair work was being performed.

SUPPLEMENTAL:

Additional Fiscal Information

The estimated amount of this contract, prior to the commencement of work, was \$500,000. However, this was based on a preliminary estimate of the amount of force account (time and materials) work needed to repair the road.

**SUBMITTAL TO THE BOARD OF SUPERVISORS COUNTY OF RIVERSIDE,
STATE OF CALIFORNIA**

This work was performed in accordance with the Force Account provisions of the Standard Specifications. The final Project cost is \$340,000 funded by General Fund Contingency.

Contract History and Price Reasonableness

N/A

ATTACHMENTS:

Vicinity Map
Attachment "A", Project Costs and Budget
Contract, Bonds, and Insurance
Specifications and Contract Documents book
Schedule A



Jason Farin, Principal Management Analyst 6/26/2024



Aaron Gettis, Chief of Deputy County Counsel 5/23/2024

COUNTY OF RIVERSIDE TRANSPORTATION DEPARTMENT

Emergency Road and Storm Drain Damage Repair Work

Pedley Road, Emergency Access Road

Western Riverside County/City Animal Shelter

PROJECT No. D4-0135

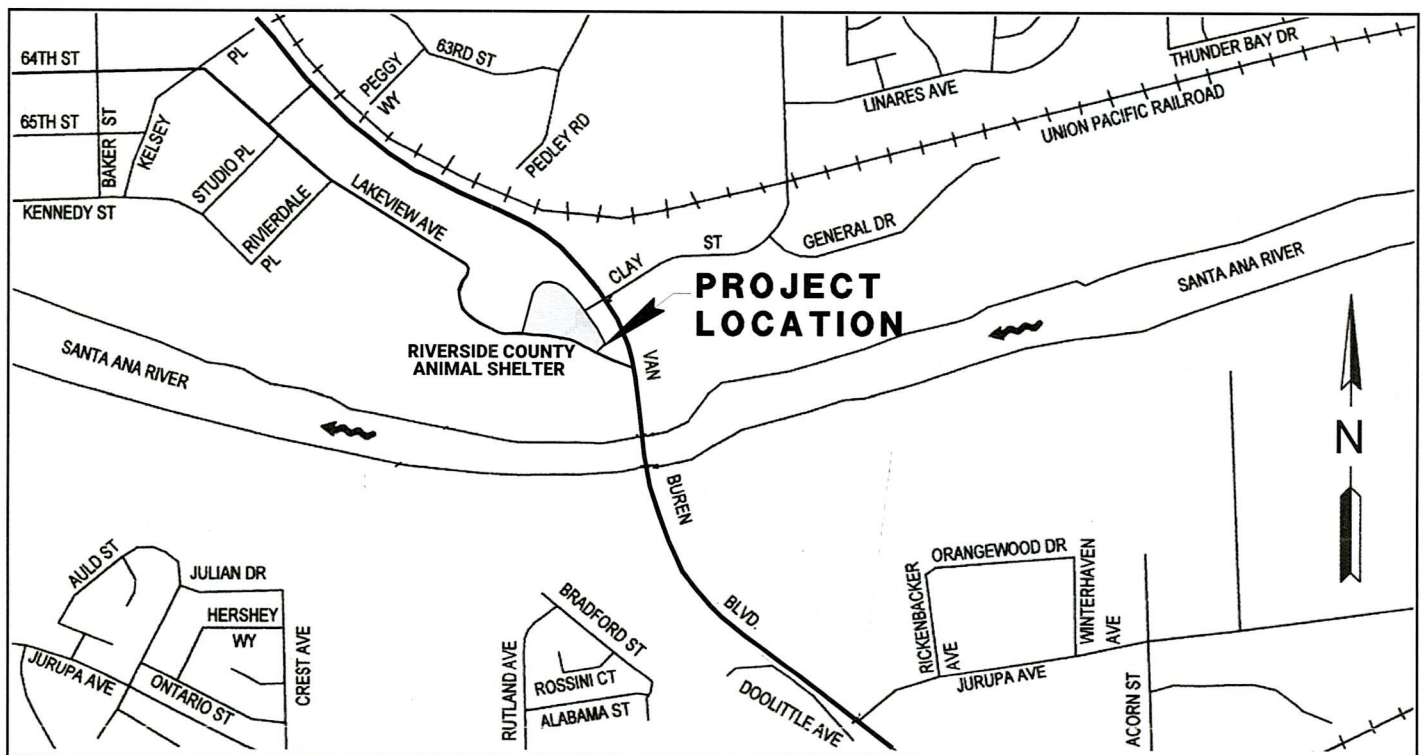
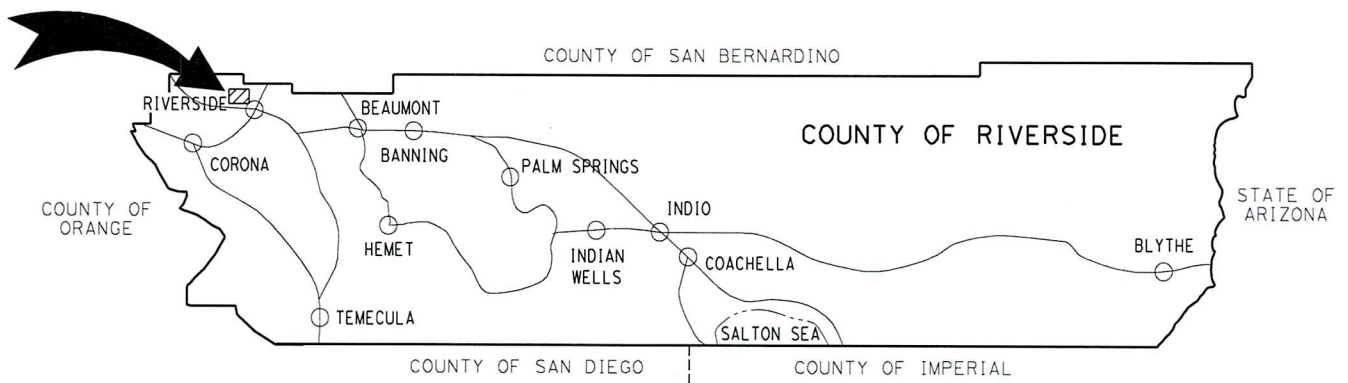

VICINITY MAP

Contract

THIS CONTRACT is entered into at Riverside, California as of the date set forth below is between County of Riverside hereafter called "County" and **Riverside Construction Company, Inc.**, hereafter called "Contractor".

W I T N E S S E T H

Recitals:

1. Contractor has submitted to County his Contractor's Proposal for the construction of County Project, **Emergency Road and Storm Drain Damage Repair Work, Pedley Road, Emergency Access Road, Western Riverside County/City Animal Shelter, Project No. D4-0135**, in strict accordance with the Contract Documents identified below and County has accepted said Proposal.
2. Contractor states that he has reexamined his Contractor's Proposal and found it to be correct, has ascertained that his subcontractors are properly licensed and possess the requisite skill and forces, has reexamined the site and Contract Documents and is of the opinion that he can presently do the work in accordance with the Contract Documents for the money set forth in his Proposal to be paid as provided in the Contract Documents.

Agreement:

It is agreed by the parties as follows:

1. Contract Documents

The entire Contract consists of the following: (a) The Construction Contract, (b) The Bid, (c) The Payment Bond, (d) The Performance Bond, (e) The General Conditions, (f) The Special Provisions, (g) The Standard Specifications of the State of California Department of Transportation edition of **2018** as modified in other portions of the Contract Documents and as amended by the State of California Department of Transportation, (h) The Standard Plans of the Department of Transportation identified on the plans or in the Special Provisions, (i) The Plans, (j) The Determination of Prevailing Wage Rates for Public Works, (k) Any Change Orders issued, and (l) Any additional or supplemental specifications, notice, instructions and drawings issued in accordance with the provisions of the Contract Documents. All of said Documents presently in existence are by this reference incorporated herein with like effect as if here set forth in full and upon the proper issuance of other documents they shall likewise be deemed incorporated. The Bid Bond is exonerated upon execution of this Contract and the Payment Bond and Performance Bond.

2. The Work

Contractor shall do all emergency repairs necessary to construct the work generally described in Recital No. 1 and Special Provisions in accordance with the Contract Documents.

3. Prosecution, Progress and Liquidated Damages

Attention is directed to the provisions in Section 8-1.04, "Start of Job Site Activities", Section 8-1.05, "Time", and in Section 8-1.10 "Liquidated Damages" of the Standard Specifications and these Special Provisions.

Standard Specification Section 8-1.04B, "Standard Start" is modified to read as follows:

The Contractor shall begin work within **two (2) calendar days**, or as revised in the Special Provisions, of the date stated within the written "Notice to Proceed".

The Contractor shall notify the Engineer, in writing, of the Contractor's intent to begin work **at least 24 hours before work** is begun. If the project has more than one (1) location of work, Contractor shall submit a separate notice for each location. The notice shall be delivered to the Transportation Department's Construction Engineer and shall specify the date the Contractor intends to start at said location.

Should the Contractor begin work in advance of receiving a written "Notice to Proceed", any work performed by the Contractor in advance of the date stated in the "Notice to Proceed" shall be considered as having been done by the Contractor at his own risk and as a volunteer and subject to the following:

- A. The Contractor shall, on commencing operations, take all precautions required for public safety and shall observe all the provisions in the Specifications and the Special Provisions.
- B. All work done according to the Contract, prior to the issuance of the "Notice to Proceed", will be considered authorized work and will be paid for as provided in the contract.
- C. The Contractor shall not be entitled to any additional compensation or an extension of time for any delay, hindrance or interference caused by or attributable to commencement of work prior to the issuance of the "Notice to Proceed".

4. Compensation

The Contractor agrees to receive and accept payment, on a force-account basis, as full compensation for furnishing all materials and for doing all the work contemplated and embraced in this Contract, until its acceptance by the County of Riverside, and for well and faithfully completing the work, and the whole thereof, in the manner according to the specifications, and the requirements of the Engineer.

The estimated cost for this project, prior to commencement of work, is **\$500,000.00 (Five hundred thousand dollars and zero cents)**.

**Emergency Road and Storm Drain Damage Repair Work
Pedley Road, Emergency Access Road
Western Riverside County/City Animal Shelter
Project No. D4-0135**

IN WITNESS WHEREOF the parties hereto have executed this Contract as of the date set forth below.

COUNTY OF RIVERSIDE

RIVERSIDE CONSTRUCTION COMPANY, INC.

BY: _____

BY: _____

Dennis Acuna

Director of Transportation

Delegated authority for emergency contracts per Resolution No. 93-047, currently adopted by Resolution No. 2019-035 (January 29, 2019; Agenda Item 3.24)

TITLE: Donald M. Pim, President
(If Corporation, affix Seal)

DATED: _____

4/10/2024

ATTEST: _____

TITLE: Bryan Lounsbury, Secretary/Treasurer

FORM APPROVED COUNTY COUNSEL

BY: _____

DANIELLE D. MALAND

Licensed in accordance with an act providing for the registration of Contractors,

License No.: 266222

Federal Employer Identification Number:

95-2662331

Department of Industrial Relations Registration Number:

1000003993

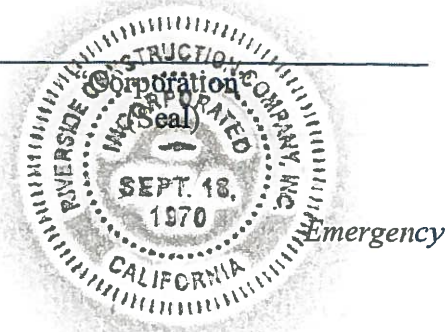

CORPORATE RESOLUTION
OF
RIVERSIDE CONSTRUCTION COMPANY, INC.

December 10, 2020

A meeting of the Board of Directors of Riverside Construction Company, Inc., a California Corporation, was held on December 10, 2020, duly called pursuant to written notice, at which a quorum was present and voting.

The Directors hereby adopt the following recitals, resolutions, and statements pursuant to the Corporation's By-Laws permitting such action to be taken effective January 1, 2021:

OFFICERS – SIGNING CONTRACTS AND OTHER INSTRUMENTS

WHEREAS, The duly elected Directors of the Corporation are Donald M. Pim – Chairman, Richard W. Gove, Kevin M. Kelly, and Bryan M. Lounsbury.

WHEREAS, The Board of Directors may authorize any officer or officers to enter into any Contract or Execute any Instrument in the name of and on behalf of the Corporation.

WHEREAS, The officers of the Corporation are President, Executive Vice President, Vice President, Secretary, and Treasurer.

NOW, THEREFORE, BE IT RESOLVED, that pursuant to the By-Laws of the Corporation, Article IV-Section 5, the following officers of the Corporation designated by the Board of Directors shall be and are authorized and empowered to enter into and Execute any Contract, and or Execute any Instrument in the name of and on behalf of the Corporation. The Corporation Officers referred to herein are now held by the following persons, whose title and signature appear after their respective name;

(Officer) Donald M. Pim – President:



(Officer) Richard G. Lounsbury – Executive Vice President:



(Officer) Jason A. Moore – Vice President:



(Officer) Bryan M. Lounsbury - Secretary / Treasurer:



RESOLVED, FURTHER, that the following officers of the Corporation designated by the Board of Directors shall be and are authorized and empowered to execute contract change orders in the name of and on behalf of the Corporation. The Corporation Officers referred to herein are held by the following persons, whose title and signature appear after their respective name;

(Officer) Gregory G. Camp, Jr. – Vice President:

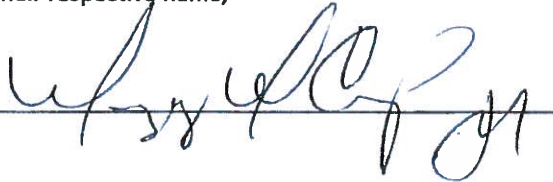

RESOLVED, FURTHER, that the authority conferred to the Corporation officers hereinabove may be exercised individually or jointly by any of such officers and shall continue in full force and effect until modification or revocation by the Board of Directors of the Corporation.

RESOLVED, FURTHER, that the Secretary of the Corporation is instructed to insert this resolution in the Corporation's Minute Book.

IN WITNESS WHEREOF, The undersigned, constituting all the Directors of the Corporation, hereby adopt this Resolution in the name of and behalf of the Corporation effective on the date first set forth above.

By: 

Donald M. Pim – Chairman/Director

By: 

Richard W. Gove – Director

By: 

Kevin M. Kelly – Director

By: 

Bryan M. Lounsbury - Director

Performance Bond

Recitals:

1. **Riverside Construction Company, Inc.** (Contractor) has entered into a Contract with COUNTY OF RIVERSIDE (County) for construction of public work known as **Emergency Road and Storm Drain Damage Repair Work, Pedley Road, Emergency Access Road, Western Riverside County/City Animal Shelter, Project No. D4-0135.**
2. Fidelity and Deposit Company of Maryland, a Illinois corporation (Surety), is the Surety under this Bond.

Agreement:

We, Contractor as Principal and Surety as Surety, jointly and severally agree, state, and are bound unto County, as obligee, as follows:

1. The amount of the obligation of this Bond is 100% of the estimated contract price for the Project of **\$500,000.00 (Five hundred thousand dollars and zero cents)** and inures to the benefit of County.
2. This Bond is exonerated by Contractor doing all things to be kept and performed by it in strict conformance with the Contract Documents for this project, otherwise it remains in full force and effect for the recovery of loss, damage and expense of County resulting from failure of Contractor to so act. All of said Contract Documents are incorporated herein.
3. This obligation is binding on our successors and assigns.
4. For value received, Surety stipulates and agrees that no change, time extension, prepayment to Contractor, alteration or addition to the terms and requirements of the Contract Documents or the work to be performed thereunder shall affect its obligations hereunder and waives notice as to such matters, except the total contract price cannot be increased by more than 10% without approval of Surety.

THIS BOND is executed as of April 11, 2024
Riverside Construction Company, Inc.

By Donald M. Pim
By Donald M. Pim

Fidelity and Deposit Company of Maryland

By Margareta T. Thorsen

Type Name Margareta T. Thorsen

Its Attorney in Fact
"Surety"

DONALD M. PIM
 Title: **PRESIDENT**
 Contractor"
 (Corporate Seal)

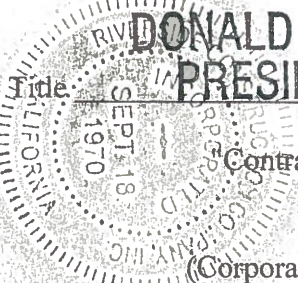

(Corporate Seal)



NOTE: This Bond must be executed by both parties with corporate seal affixed. All signatures must be acknowledged. (Attach acknowledgements).

CALIFORNIA ALL-PURPOSE ACKNOWLEDGEMENT

CIVIL CODE § 1189

A notary public or other officer completing this certificate verifies only the identity of the individual who signed the document to which this certificate is attached, and not the truthfulness, accuracy, or validity of that document.

State of California

County of Riverside

On April 12, 2024 before me, Alyssa Helm, Notary Public,
Date Here Insert name and Title of the Officer

personally appeared Donald M. Pim
Name(s) of Signer(s)

who proved to me on the basis of satisfactory evidence to be the person(s) whose name(s) is/are subscribed to the within instrument and acknowledged to me that he/~~she~~/they executed the same in his/~~her~~/their authorized capacity(ies), and that by his/~~her~~/their signature(s) on the instrument the person(s), or the entity upon behalf of which the person(s) acted, executed the instrument.

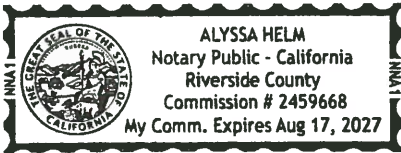

I certify under PENALTY OF PERJURY under the laws of the State of California that the foregoing paragraph is true and correct.

WITNESS my hand and official seal.

Signature [Handwritten Signature]
Signature of Notary Public

Place Notary Seal and/or Stamp Above

OPTIONAL

Though the information below is not required by law, it may prove valuable to person relying on the document and could prevent fraudulent removal and reattachment of this form to another document.

Description of Attached Document

Title or Type of Document _____

Document Date: _____ Number of Pages: _____

Signer(s) Other Than Named Above: _____

Capacity(ies) Claimed by Signer(s)

Signer's Name: _____

- Individual
- Corporate Officer — Title(s): _____
- Partner Limited General
- Attorney in Fact
- Trustee
- Other: _____

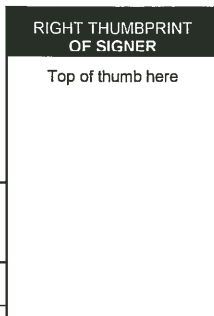

Signer is Representing:

Signer's Name: _____

- Individual
- Corporate Officer — Title(s): _____
- Partner Limited General
- Attorney in Fact
- Trustee
- Other: _____

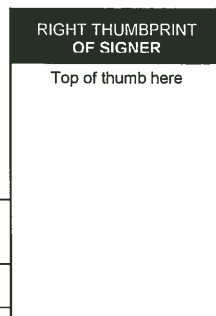

Signer is Representing:

CALIFORNIA ALL-PURPOSE ACKNOWLEDGMENT

A notary public or other officer completing this certificate verifies only the identity of the individual who signed the document to which this certificate is attached, and not the truthfulness, accuracy, or validity of that document.

STATE OF CALIFORNIA

County of Sacramento }

On 4/11/24 before me, Sandra R. Black, Notary Public,
Date Insert Name of Notary exactly as it appears on the official seal

personally appeared Margareta T. Thorsen
Name(s) of Signer(s)



Place Notary Seal Above

who proved to me on the basis of satisfactory evidence to be the person(s) whose name(s) is/are subscribed to the within instrument and acknowledged to me that he/she/they executed the same in his/her/their authorized capacity(ies), and that by his/her/their signature(s) on the instrument the person(s), or the entity upon behalf of which the person(s) acted, executed the instrument.

I certify under PENALTY OF PERJURY under the laws of the State of California that the foregoing paragraph is true and correct.

Witness my hand and official seal.

Signature [Handwritten Signature]
Signature of Notary Public

OPTIONAL

Though the information below is not required by law, it may prove valuable to persons relying on the document and could prevent fraudulent removal and reattachment of the form to another document.

Description of Attached Document

Title or Type of Document: _____

Document Date: _____ Number of Pages: _____

Signer(s) Other Than Named Above: _____

Capacity(ies) Claimed by Signer(s)

Signer's Name: _____

- Individual
- Corporate Officer — Title(s): _____
- Partner Limited General
- Attorney in Fact
- Trustee
- Guardian or Conservator
- Other: _____

RIGHT THUMBPRINT
OF SIGNER
Top of thumb here

Signer is Representing:

Signer's Name: _____

- Individual
- Corporate Officer — Title(s): _____
- Partner Limited General
- Attorney in Fact
- Trustee
- Guardian or Conservator
- Other: _____

RIGHT THUMBPRINT
OF SIGNER
Top of thumb here

Signer is Representing:

EXTRACT FROM BY-LAWS OF THE COMPANIES

"Article V, Section 8, Attorneys-in-Fact. The Chief Executive Officer, the President, or any Executive Vice President or Vice President may, by written instrument under the attested corporate seal, appoint attorneys-in-fact with authority to execute bonds, policies, recognizances, stipulations, undertakings, or other like instruments on behalf of the Company, and may authorize any officer or any such attorney-in-fact to affix the corporate seal thereto; and may with or without cause modify or revoke any such appointment or authority at any time."

CERTIFICATE

I, the undersigned, Secretary of the ZURICH AMERICAN INSURANCE COMPANY, the COLONIAL AMERICAN CASUALTY AND SURETY COMPANY, and the FIDELITY AND DEPOSIT COMPANY OF MARYLAND, do hereby certify that the foregoing Power of Attorney is still in full force and effect on the date of this certificate; and I do further certify that Article V, Section 8, of the By-Laws of the Companies is still in force.

This Power of Attorney and Certificate may be signed by facsimile under and by authority of the following resolution of the Board of Directors of the ZURICH AMERICAN INSURANCE COMPANY at a meeting duly called and held on the 15th day of December 1998.

RESOLVED: "That the signature of the President or a Vice President and the attesting signature of a Secretary or an Assistant Secretary and the Seal of the Company may be affixed by facsimile on any Power of Attorney...Any such Power or any certificate thereof bearing such facsimile signature and seal shall be valid and binding on the Company."

This Power of Attorney and Certificate may be signed by facsimile under and by authority of the following resolution of the Board of Directors of the COLONIAL AMERICAN CASUALTY AND SURETY COMPANY at a meeting duly called and held on the 5th day of May, 1994, and the following resolution of the Board of Directors of the FIDELITY AND DEPOSIT COMPANY OF MARYLAND at a meeting duly called and held on the 10th day of May, 1990.

RESOLVED: "That the facsimile or mechanically reproduced seal of the company and facsimile or mechanically reproduced signature of any Vice-President, Secretary, or Assistant Secretary of the Company, whether made heretofore or hereafter, wherever appearing upon a certified copy of any power of attorney issued by the Company, shall be valid and binding upon the Company with the same force and effect as though manually affixed.

IN TESTIMONY WHEREOF, I have hereunto subscribed my name and affixed the corporate seals of the said Companies, this 11th day of April, 2024.

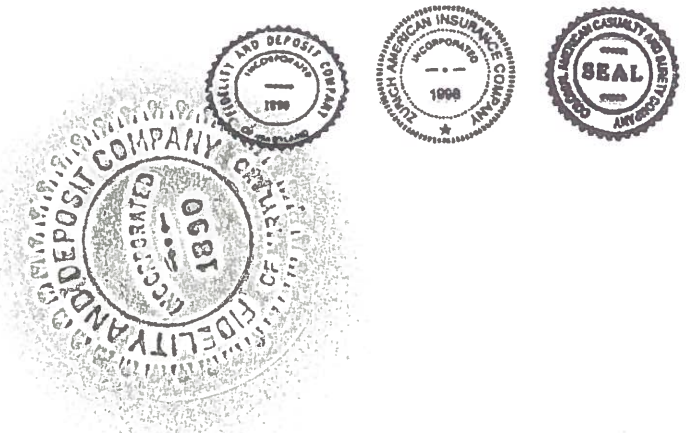

Brian M. Hodges

By: Brian M. Hodges
Vice President

TO REPORT A CLAIM WITH REGARD TO A SURETY BOND, PLEASE SUBMIT A COMPLETE DESCRIPTION OF THE CLAIM INCLUDING THE PRINCIPAL ON THE BOND, THE BOND NUMBER, AND YOUR CONTACT INFORMATION TO:

Zurich Surety Claims
1299 Zurich Way
Schaumburg, IL 60196-1056
www.reportsfclaims@zurichna.com
800-626-4577

**ZURICH AMERICAN INSURANCE COMPANY
COLONIAL AMERICAN CASUALTY AND SURETY
COMPANY
FIDELITY AND DEPOSIT COMPANY OF MARYLAND
POWER OF ATTORNEY**

KNOW ALL MEN BY THESE PRESENTS: That the ZURICH AMERICAN INSURANCE COMPANY, a corporation of the State of New York, the COLONIAL AMERICAN CASUALTY AND SURETY COMPANY, a corporation of the State of Illinois, and the FIDELITY AND DEPOSIT COMPANY OF MARYLAND a corporation of the State of Illinois (herein collectively called the "Companies"), by **Robert D. Murray, Vice President**, in pursuance of authority granted by Article V, Section 8, of the By-Laws of said Companies, which are set forth on the reverse side hereof and are hereby certified to be in full force and effect on the date hereof, do hereby nominate, constitute, and appoint **Margareta T. THORSEN of Pasadena, California**, its true and lawful agent and Attorney-in-Fact, to make, execute, seal and deliver, for, and on its behalf as surety, and as its act and deed: any and all bonds and undertakings, and the execution of such bonds or undertakings in pursuance of these presents, shall be as binding upon said Companies, as fully and amply, to all intents and purposes, as if they had been duly executed and acknowledged by the regularly elected officers of the ZURICH AMERICAN INSURANCE COMPANY at its office in New York, New York., the regularly elected officers of the COLONIAL AMERICAN CASUALTY AND SURETY COMPANY at its office in Owings Mills, Maryland, and the regularly elected officers of the FIDELITY AND DEPOSIT COMPANY OF MARYLAND at its office in Owings Mills, Maryland, in their own proper persons.

The said Vice President does hereby certify that the extract set forth on the reverse side hereof is a true copy of Article V, Section 8, of the By-Laws of said Companies and is now in force.

IN WITNESS WHEREOF, the said Vice-President has hereunto subscribed his/her names and affixed the Corporate Seals of the said **ZURICH AMERICAN INSURANCE COMPANY, COLONIAL AMERICAN CASUALTY AND SURETY COMPANY, and FIDELITY AND DEPOSIT COMPANY OF MARYLAND**, this 28th day of April, A.D. 2020.



**ATTEST:
ZURICH AMERICAN INSURANCE COMPANY
COLONIAL AMERICAN CASUALTY AND SURETY COMPANY
FIDELITY AND DEPOSIT COMPANY OF MARYLAND**

By: *Robert D. Murray*
Vice President

By: *Dawn E. Brown*
Secretary

**State of Maryland
County of Baltimore**

On this 28th day of April, A.D. 2020, before the subscriber, a Notary Public of the State of Maryland, duly commissioned and qualified, **Robert D. Murray, Vice President and Dawn E. Brown, Secretary** of the Companies, to me personally known to be the individuals and officers described in and who executed the preceding instrument, and acknowledged the execution of same, and being by me duly sworn, depose and saith, that he/she is the said officer of the Company aforesaid, and that the seals affixed to the preceding instrument are the Corporate Seals of said Companies, and that the said Corporate Seals and the signature as such officer were duly affixed and subscribed to the said instrument by the authority and direction of the said Corporations.

IN TESTIMONY WHEREOF, I have hereunto set my hand and affixed my Official Seal the day and year first above written.



Constance A. Dunn, Notary Public
My Commission Expires: July 9, 2023

- Company Profile
- Company Search
- Company Search Results
- Company Information
- Old Company Names
- Agent for Service Reference Information
- NAIC Group List
- Lines of Business
- Workers' Compensation Complaint and Request for Action/Appeals Contact Information
- Financial Statements PDF's
 - Annual Statements
 - Quarterly Statements
- Company Complaint
- Company Performance & Comparison Data
- Company Enforcement Action
- Composite Complaints Studies
- Additional Info
 - Find A Company Representative In Your Area
 - View Financial Disclaimer

COMPANY PROFILE

Company Information

FIDELITY AND DEPOSIT COMPANY OF MARYLAND

**1299 ZURICH WAY
SCHAUMBURG, IL 60196
800-382-2150**

Old Company Names

Effective Date

Agent For Service

Melissa DeKoven
2710 Gateway Oaks Drive, Suite 150N
Sacramento CA 95833-3505

Reference Information

NAIC #:	39306
California Company ID #:	2479-4
Date Authorized in California:	01/01/1982
License Status:	UNLIMITED-NORMAL
Company Type:	Property & Casualty
State of Domicile:	ILLINOIS

[back to top](#)

NAIC Group List

NAIC Group #: [0212](#) ZURICH INS GRP

Lines Of Business

The company is authorized to transact business within these lines of insurance. For an explanation of any of these terms, please refer to the [glossary](#).

- AIRCRAFT
- AUTOMOBILE
- BOILER AND MACHINERY
- BURGLARY
- CREDIT
- FIRE
- LIABILITY
- MARINE
- MISCELLANEOUS
- PLATE GLASS
- SPRINKLER
- SURETY
- TEAM AND VEHICLE
- WORKERS' COMPENSATION

[back to top](#)

Payment Bond

(Public Works - Civil Code §9550 et seq.)

The makers of this Bond are **Riverside Construction Company, Inc.**, as Principal and Original Contractor and Fidelity and Deposit Company of Maryland, a corporation, authorized to issue Surety Bonds in California, as Surety, and this Bond is issued in conjunction with that certain public works contract to be executed between Principal and COUNTY OF RIVERSIDE a public entity, as Owner, for **\$500,000.00 (Five hundred thousand dollars and zero cents)**, the total amount payable. The amount of this bond is one hundred percent (100%) of said sum. Said contract is for public work generally consisting of **Emergency Road and Storm Drain Damage Repair Work, Pedley Road, Emergency Access Road, Western Riverside County/City Animal Shelter, Project No. D4-0135.**

The beneficiaries of this Bond are as is stated in 9554 of the Civil Code and requirements and conditions of this Bond are as is set forth in 9554, 9558, 9560 and 9564 of said code. Without notice, Surety consents to extension of time for performance, change in requirements, amount of compensation, or prepayment under said contract.

Dated: April 11, 2024

Riverside Construction Company, Inc.

Original Contractor – Principal

Fidelity and Deposit Company of Maryland

By Donald M. Pim

Surety

**DONALD M. PIM
PRESIDENT**

By Margareta T. Thorsen

Title _____

Margareta T. Thorsen
Attorney In Fact

(If corporation, affix seal)

(Corporate Seal)

(Corporate Seal)

COUNTY OF _____

} ss. SURETY'S ACKNOWLEDGEMENT

See attached CA All Purpose Acknowledgement

On _____ before me, _____ personally appeared, _____, known to me, or proved to me on the basis of satisfactory evidence, to be the person whose name is subscribed to the within instrument and acknowledged to me that he executed the same in his authorized capacities, and that by his signature on the instrument the person, or the entity upon behalf of which the person acted, executed the instrument.

WITNESS my hand and official seal.

Signature of Notary Public

Notary Public (Seal)

NOTE: This Bond must be executed by both parties with corporate seal affixed. All signatures must be acknowledged. (Attach acknowledgements).

CALIFORNIA ALL-PURPOSE ACKNOWLEDGEMENT

CIVIL CODE § 1189

A notary public or other officer completing this certificate verifies only the identity of the individual who signed the document to which this certificate is attached, and not the truthfulness, accuracy, or validity of that document.

State of California

County of Riverside

On April 12, 2024 before me, Alyssa Helm, Notary Public,
Date Here Insert name and Title of the Officer

personally appeared Donald M. Pim
Name(s) of Signer(s)

who proved to me on the basis of satisfactory evidence to be the person(s) whose name(s) is/are subscribed to the within instrument and acknowledged to me that he/she/they executed the same in his/her/their authorized capacity(ies), and that by his/her/their signature(s) on the instrument the person(s), or the entity upon behalf of which the person(s) acted, executed the instrument.

I certify under PENALTY OF PERJURY under the laws of the State of California that the foregoing paragraph is true and correct.

WITNESS my hand and official seal

Signature [Handwritten Signature]
Signature of Notary Public

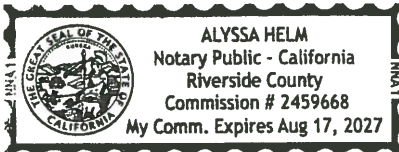

Place Notary Seal and/or Stamp Above

OPTIONAL

Though the information below is not required by law, it may prove valuable to person relying on the document and could prevent fraudulent removal and reattachment of this form to another document.

Description of Attached Document

Title or Type of Document _____

Document Date: _____ Number of Pages: _____

Signer(s) Other Than Named Above: _____

Capacity(ies) Claimed by Signer(s)

Signer's Name: _____

- Individual
- Corporate Officer — Title(s): _____
- Partner Limited General
- Attorney in Fact
- Trustee
- Other: _____

RIGHT THUMBPRINT OF SIGNER

Top of thumb here

Signer is Representing:

Signer's Name: _____

- Individual
- Corporate Officer — Title(s): _____
- Partner Limited General
- Attorney in Fact
- Trustee
- Other: _____

RIGHT THUMBPRINT OF SIGNER

Top of thumb here

Signer is Representing:

CALIFORNIA ALL-PURPOSE ACKNOWLEDGMENT

A notary public or other officer completing this certificate verifies only the identity of the individual who signed the document to which this certificate is attached, and not the truthfulness, accuracy, or validity of that document.

STATE OF CALIFORNIA

County of Sacramento }

On 4/11/24 before me, Sandra R. Black, Notary Public,
Date Insert Name of Notary exactly as it appears on the official seal

personally appeared Margareta T. Thorsen
Name(s) of Signer(s)

who proved to me on the basis of satisfactory evidence to be the person(s) whose name(s) is/are subscribed to the within instrument and acknowledged to me that he/she/they executed the same in his/her/their authorized capacity(ies), and that by his/her/their signature(s) on the instrument the person(s), or the entity upon behalf of which the person(s) acted, executed the instrument.

I certify under PENALTY OF PERJURY under the laws of the State of California that the foregoing paragraph is true and correct.

Witness my hand and official seal.

Signature [Handwritten Signature]
Signature of Notary Public



Place Notary Seal Above

OPTIONAL

Though the information below is not required by law, it may prove valuable to persons relying on the document and could prevent fraudulent removal and reattachment of the form to another document.

Description of Attached Document

Title or Type of Document: _____

Document Date: _____ Number of Pages: _____

Signer(s) Other Than Named Above: _____

Capacity(ies) Claimed by Signer(s)

Signer's Name: _____

- Individual
- Corporate Officer — Title(s): _____
- Partner Limited General
- Attorney in Fact
- Trustee
- Guardian or Conservator
- Other: _____

RIGHT THUMBPRINT
OF SIGNER
Top of thumb here

Signer is Representing:

Signer's Name: _____

- Individual
- Corporate Officer — Title(s): _____
- Partner Limited General
- Attorney in Fact
- Trustee
- Guardian or Conservator
- Other: _____

RIGHT THUMBPRINT
OF SIGNER
Top of thumb here

Signer is Representing:

**ZURICH AMERICAN INSURANCE COMPANY
COLONIAL AMERICAN CASUALTY AND SURETY
COMPANY
FIDELITY AND DEPOSIT COMPANY OF MARYLAND
POWER OF ATTORNEY**

KNOW ALL MEN BY THESE PRESENTS: That the ZURICH AMERICAN INSURANCE COMPANY, a corporation of the State of New York, the COLONIAL AMERICAN CASUALTY AND SURETY COMPANY, a corporation of the State of Illinois, and the FIDELITY AND DEPOSIT COMPANY OF MARYLAND a corporation of the State of Illinois (herein collectively called the "Companies"), by **Robert D. Murray, Vice President**, in pursuance of authority granted by Article V, Section 8, of the By-Laws of said Companies, which are set forth on the reverse side hereof and are hereby certified to be in full force and effect on the date hereof, do hereby nominate, constitute, and appoint **Margareta T. THORSEN of Pasadena, California**, its true and lawful agent and Attorney-in-Fact, to make, execute, seal and deliver, for, and on its behalf as surety, and as its act and deed: any and all bonds and undertakings, and the execution of such bonds or undertakings in pursuance of these presents, shall be as binding upon said Companies, as fully and amply, to all intents and purposes, as if they had been duly executed and acknowledged by the regularly elected officers of the ZURICH AMERICAN INSURANCE COMPANY at its office in New York, New York., the regularly elected officers of the COLONIAL AMERICAN CASUALTY AND SURETY COMPANY at its office in Owings Mills, Maryland, and the regularly elected officers of the FIDELITY AND DEPOSIT COMPANY OF MARYLAND at its office in Owings Mills, Maryland, in their own proper persons.

The said Vice President does hereby certify that the extract set forth on the reverse side hereof is a true copy of Article V, Section 8, of the By-Laws of said Companies and is now in force.

IN WITNESS WHEREOF, the said Vice-President has hereunto subscribed his/her names and affixed the Corporate Seals of the said **ZURICH AMERICAN INSURANCE COMPANY, COLONIAL AMERICAN CASUALTY AND SURETY COMPANY, and FIDELITY AND DEPOSIT COMPANY OF MARYLAND**, this 28th day of April, A.D. 2020.



**ATTEST:
ZURICH AMERICAN INSURANCE COMPANY
COLONIAL AMERICAN CASUALTY AND SURETY COMPANY
FIDELITY AND DEPOSIT COMPANY OF MARYLAND**

By: *Robert D. Murray*
Vice President

By: *Dawn E. Brown*
Secretary

**State of Maryland
County of Baltimore**

On this 28th day of April, A.D. 2020, before the subscriber, a Notary Public of the State of Maryland, duly commissioned and qualified, **Robert D. Murray, Vice President and Dawn E. Brown, Secretary** of the Companies, to me personally known to be the individuals and officers described in and who executed the preceding instrument, and acknowledged the execution of same, and being by me duly sworn, depose and saith, that he/she is the said officer of the Company aforesaid, and that the seals affixed to the preceding instrument are the Corporate Seals of said Companies, and that the said Corporate Seals and the signature as such officer were duly affixed and subscribed to the said instrument by the authority and direction of the said Corporations.

IN TESTIMONY WHEREOF, I have hereunto set my hand and affixed my Official Seal the day and year first above written.

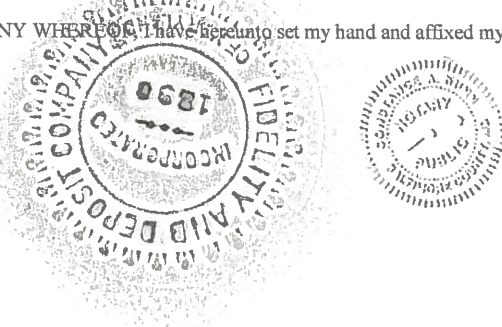

Constance A. Dunn, Notary Public
My Commission Expires: July 9, 2023

EXTRACT FROM BY-LAWS OF THE COMPANIES

"Article V, Section 8, Attorneys-in-Fact. The Chief Executive Officer, the President, or any Executive Vice President or Vice President may, by written instrument under the attested corporate seal, appoint attorneys-in-fact with authority to execute bonds, policies, recognizances, stipulations, undertakings, or other like instruments on behalf of the Company, and may authorize any officer or any such attorney-in-fact to affix the corporate seal thereto; and may with or without cause modify or revoke any such appointment or authority at any time."

CERTIFICATE

I, the undersigned, Secretary of the ZURICH AMERICAN INSURANCE COMPANY, the COLONIAL AMERICAN CASUALTY AND SURETY COMPANY, and the FIDELITY AND DEPOSIT COMPANY OF MARYLAND, do hereby certify that the foregoing Power of Attorney is still in full force and effect on the date of this certificate; and I do further certify that Article V, Section 8, of the By-Laws of the Companies is still in force.

This Power of Attorney and Certificate may be signed by facsimile under and by authority of the following resolution of the Board of Directors of the ZURICH AMERICAN INSURANCE COMPANY at a meeting duly called and held on the 15th day of December 1998.

RESOLVED: "That the signature of the President or a Vice President and the attesting signature of a Secretary or an Assistant Secretary and the Seal of the Company may be affixed by facsimile on any Power of Attorney...Any such Power or any certificate thereof bearing such facsimile signature and seal shall be valid and binding on the Company."

This Power of Attorney and Certificate may be signed by facsimile under and by authority of the following resolution of the Board of Directors of the COLONIAL AMERICAN CASUALTY AND SURETY COMPANY at a meeting duly called and held on the 5th day of May, 1994, and the following resolution of the Board of Directors of the FIDELITY AND DEPOSIT COMPANY OF MARYLAND at a meeting duly called and held on the 10th day of May, 1990.

RESOLVED: "That the facsimile or mechanically reproduced seal of the company and facsimile or mechanically reproduced signature of any Vice-President, Secretary, or Assistant Secretary of the Company, whether made heretofore or hereafter, wherever appearing upon a certified copy of any power of attorney issued by the Company, shall be valid and binding upon the Company with the same force and effect as though manually affixed.

IN TESTIMONY WHEREOF, I have hereunto subscribed my name and affixed the corporate seals of the said Companies, this 11th day of April, 2024.

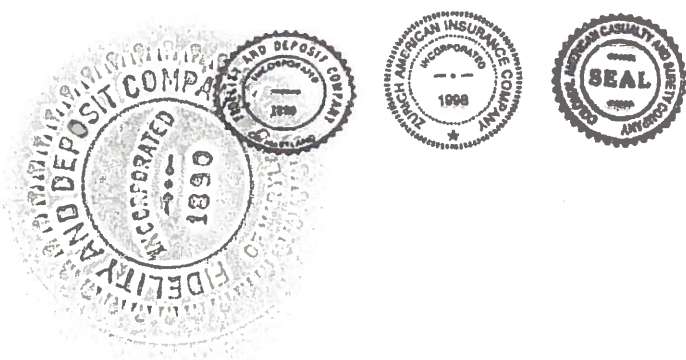

Brian M. Hodges

By: Brian M. Hodges
Vice President

TO REPORT A CLAIM WITH REGARD TO A SURETY BOND, PLEASE SUBMIT A COMPLETE DESCRIPTION OF THE CLAIM INCLUDING THE PRINCIPAL ON THE BOND, THE BOND NUMBER, AND YOUR CONTACT INFORMATION TO:

Zurich Surety Claims
1299 Zurich Way
Schaumburg, IL 60196-1056
www.reportsfclaims@zurichna.com
800-626-4577

- Company Profile
- Company Search
- Company Search Results
- Company Information
- Old Company Names
- Agent for Service Reference Information
- NAIC Group List
- Lines of Business
- Workers' Compensation Complaint and Request for Action/Appeals Contact Information
- Financial Statements PDF's
 - Annual Statements
 - Quarterly Statements
- Company Complaint
- Company Performance & Comparison Data
- Company Enforcement Action
- Composite Complaints Studies
- Additional Info
 - Find A Company Representative In Your Area
 - View Financial Disclaimer

COMPANY PROFILE

Company Information

FIDELITY AND DEPOSIT COMPANY OF MARYLAND

**1299 ZURICH WAY
SCHAUMBURG, IL 60196
800-382-2150**

Old Company Names

Effective Date

Agent For Service

Melissa DeKoven
2710 Gateway Oaks Drive, Suite 150N
Sacramento CA 95833-3505

Reference Information

NAIC #:	39306
California Company ID #:	2479-4
Date Authorized in California:	01/01/1982
License Status:	UNLIMITED-NORMAL
Company Type:	Property & Casualty
State of Domicile:	ILLINOIS

[back to top](#)

NAIC Group List

NAIC Group #: **0212** ZURICH INS GRP

Lines Of Business

The company is authorized to transact business within these lines of insurance. For an explanation of any of these terms, please refer to the [glossary](#).

- AIRCRAFT
- AUTOMOBILE
- BOILER AND MACHINERY
- BURGLARY
- CREDIT
- FIRE
- LIABILITY
- MARINE
- MISCELLANEOUS
- PLATE GLASS
- SPRINKLER
- SURETY
- TEAM AND VEHICLE
- WORKERS' COMPENSATION

[back to top](#)



CERTIFICATE OF LIABILITY INSURANCE

DATE (MM/DD/YYYY)

4/11/2024

THIS CERTIFICATE IS ISSUED AS A MATTER OF INFORMATION ONLY AND CONFERS NO RIGHTS UPON THE CERTIFICATE HOLDER. THIS CERTIFICATE DOES NOT AFFIRMATIVELY OR NEGATIVELY AMEND, EXTEND OR ALTER THE COVERAGE AFFORDED BY THE POLICIES BELOW. THIS CERTIFICATE OF INSURANCE DOES NOT CONSTITUTE A CONTRACT BETWEEN THE ISSUING INSURER(S), AUTHORIZED REPRESENTATIVE OR PRODUCER, AND THE CERTIFICATE HOLDER.

IMPORTANT: If the certificate holder is an **ADDITIONAL INSURED**, the policy(ies) must have **ADDITIONAL INSURED** provisions or be endorsed. If **SUBROGATION IS WAIVED**, subject to the terms and conditions of the policy, certain policies may require an endorsement. A statement on this certificate does not confer rights to the certificate holder in lieu of such endorsement(s).

PRODUCER Edgewood Partners Insurance Center (EPIC) License No: OB29370 4675 MacArthur Court, Suite 750 Newport Beach, CA 92660 www.epicbrokers.com	CONTACT NAME: PHONE (A/C No. Ext): 949-474-1550		FAX (A/C, No):
	E-MAIL ADDRESS:		
INSURED Riverside Construction Company, Inc. P.O. Box 1146 Riverside CA 92502	INSURER(S) AFFORDING COVERAGE		NAIC #
	INSURER A: Executive Risk Indemnity Inc		35181
	INSURER B: Federal Insurance Company		20281
	INSURER C:		
	INSURER D:		
	INSURER E:		

COVERAGES

CERTIFICATE NUMBER: 79482612

REVISION NUMBER:

THIS IS TO CERTIFY THAT THE POLICIES OF INSURANCE LISTED BELOW HAVE BEEN ISSUED TO THE INSURED NAMED ABOVE FOR THE POLICY PERIOD INDICATED. NOTWITHSTANDING ANY REQUIREMENT, TERM OR CONDITION OF ANY CONTRACT OR OTHER DOCUMENT WITH RESPECT TO WHICH THIS CERTIFICATE MAY BE ISSUED OR MAY PERTAIN, THE INSURANCE AFFORDED BY THE POLICIES DESCRIBED HEREIN IS SUBJECT TO ALL THE TERMS, EXCLUSIONS AND CONDITIONS OF SUCH POLICIES. LIMITS SHOWN MAY HAVE BEEN REDUCED BY PAID CLAIMS.

INSR LTR	TYPE OF INSURANCE	ADDL INSD	SUBR WVD	POLICY NUMBER	POLICY EFF (MM/DD/YYYY)	POLICY EXP (MM/DD/YYYY)	LIMITS	
A	<input checked="" type="checkbox"/> COMMERCIAL GENERAL LIABILITY <input type="checkbox"/> CLAIMS-MADE <input checked="" type="checkbox"/> OCCUR <input checked="" type="checkbox"/> BI/PD Deductible: \$25,000 GEN'L AGGREGATE LIMIT APPLIES PER: <input type="checkbox"/> POLICY <input checked="" type="checkbox"/> PRO-JECT <input type="checkbox"/> LOC OTHER:	<input checked="" type="checkbox"/>		54309745	7/1/2023	7/1/2024	EACH OCCURRENCE	\$2,000,000
							DAMAGE TO RENTED PREMISES (Ea occurrence)	\$100,000
							MED EXP (Any one person)	\$5,000
							PERSONAL & ADV INJURY	\$2,000,000
							GENERAL AGGREGATE	\$4,000,000
							PRODUCTS - COMP/OP AGG	\$4,000,000
								\$
B	<input checked="" type="checkbox"/> AUTOMOBILE LIABILITY <input checked="" type="checkbox"/> ANY AUTO <input type="checkbox"/> OWNED AUTOS ONLY <input type="checkbox"/> SCHEDULED AUTOS <input checked="" type="checkbox"/> HIRED AUTOS ONLY <input checked="" type="checkbox"/> NON-OWNED AUTOS ONLY	<input checked="" type="checkbox"/>		54309463	7/1/2023	7/1/2024	COMBINED SINGLE LIMIT (Ea accident)	\$1,000,000
							BODILY INJURY (Per person)	\$
							BODILY INJURY (Per accident)	\$
							PROPERTY DAMAGE (Per accident)	\$
							Comp/Coll Deductible	\$2,500
	<input type="checkbox"/> UMBRELLA LIAB <input type="checkbox"/> OCCUR <input type="checkbox"/> EXCESS LIAB <input type="checkbox"/> CLAIMS-MADE <input type="checkbox"/> DED <input type="checkbox"/> RETENTION \$						EACH OCCURRENCE	\$
							AGGREGATE	\$
								\$
B	WORKERS COMPENSATION AND EMPLOYERS' LIABILITY ANY PROPRIETOR/PARTNER/EXECUTIVE OFFICER/MEMBER EXCLUDED? (Mandatory in NH) If yes, describe under DESCRIPTION OF OPERATIONS below	Y/N <input checked="" type="checkbox"/> N	N/A	54309464	7/1/2023	7/1/2024	<input checked="" type="checkbox"/> PER STATUTE <input type="checkbox"/> OTH-ER	
							E.L. EACH ACCIDENT	\$1,000,000
							E.L. DISEASE - EA EMPLOYEE	\$1,000,000
							E.L. DISEASE - POLICY LIMIT	\$1,000,000

DESCRIPTION OF OPERATIONS / LOCATIONS / VEHICLES (ACORD 101, Additional Remarks Schedule, may be attached if more space is required)

RE: D4-0135 - D4-0135 - Pedley Rd - Western Riverside County/ City Animal Shelter - 6851 Van Buren Boulevard, Jurupa Valley, CA 92509

* See Addendum

**Certificate supersedes previously issued certificate

CERTIFICATE HOLDER

D4-0135 - Pedley Rd - Western Riverside County/ City Animal Shelter

 County of Riverside
 Transportation Department
 Attn: Contracts & Bidding Unit
 3525 14th Street
 Riverside CA 92501
CANCELLATION

SHOULD ANY OF THE ABOVE DESCRIBED POLICIES BE CANCELLED BEFORE THE EXPIRATION DATE THEREOF, NOTICE WILL BE DELIVERED IN ACCORDANCE WITH THE POLICY PROVISIONS.

AUTHORIZED REPRESENTATIVE

BobbiJo DeNofa Broad

© 1988-2015 ACORD CORPORATION. All rights reserved.

ACORD 25 (2016/03)

The ACORD name and logo are registered marks of ACORD



ADDITIONAL REMARKS SCHEDULE

AGENCY Edgewood Partners Insurance Center (EPIC)		NAMED INSURED Riverside Construction Company, Inc. P.O. Box 1146 Riverside CA 92502	
POLICY NUMBER		EFFECTIVE DATE:	
CARRIER	NAIC CODE		

ADDITIONAL REMARKS

THIS ADDITIONAL REMARKS FORM IS A SCHEDULE TO ACORD FORM,

FORM NUMBER: 25 **FORM TITLE:** Certificate of Liability (03/16)

HOLDER: County of Riverside Transportation Department Attn: Contracts & Bidding Unit

ADDRESS: 3525 14th Street Riverside CA 92501

The County of Riverside, its Agencies, Districts, Special Districts and Departments, their respective directors, officers, Board of Supervisors, elected and appointed officials, employees, agents, and representatives; City of Jurupa Valley, their elected appointed officials, directors, employees, agents and representatives and Riverside County Department of Animal Services (Western Riverside County/City Animal Shelter), their elected and appointed officials, directors, employees, agents, and representatives to the extent required by written contract are additional insured with respect to General Liability and Automobile Liability. A waiver of subrogation applies in favor of the additional insureds to the extent required by written contract as allowed by applicable law with respect to Workers' Compensation. 30-day notice of cancellation, except 10 days for non-payment of premium, applies to the extent required by written contract.

THIS ENDORSEMENT CHANGES THE POLICY. PLEASE READ IT CAREFULLY.

ADDITIONAL INSURED – OWNERS, LESSEES OR CONTRACTORS – SCHEDULED PERSON OR ORGANIZATION

This endorsement modifies insurance provided under the following:

COMMERCIAL GENERAL LIABILITY COVERAGE PART

SCHEDULE

Name Of Additional Insured Person(s) Or Organization(s)	Location(s) Of Covered Operations
WHERE REQUIRED BY WRITTEN CONTRACT	ALL LOCATIONS WHERE REQUIRED BY WRITTEN CONTRACT
Information required to complete this Schedule, if not shown above, will be shown in the Declarations.	

A. Section II – Who Is An Insured is amended to include as an additional insured the person(s) or organization(s) shown in the Schedule, but only with respect to liability for "bodily injury", "property damage" or "personal and advertising injury" caused, in whole or in part, by:

1. Your acts or omissions; or
2. The acts or omissions of those acting on your behalf;

in the performance of your ongoing operations for the additional insured(s) at the location(s) designated above.

However:

1. The insurance afforded to such additional insured only applies to the extent permitted by law; and
2. If coverage provided to the additional insured is required by a contract or agreement, the insurance afforded to such additional insured will not be broader than that which you are required by the contract or agreement to provide for such additional insured.

B. With respect to the insurance afforded to these additional insureds, the following additional exclusions apply:

This insurance does not apply to "bodily injury" or "property damage" occurring after:

1. All work, including materials, parts or equipment furnished in connection with such work, on the project (other than service, maintenance or repairs) to be performed by or on behalf of the additional insured(s) at the location of the covered operations has been completed; or
2. That portion of "your work" out of which the injury or damage arises has been put to its intended use by any person or organization other than another contractor or subcontractor engaged in performing operations for a principal as a part of the same project.



C. With respect to the insurance afforded to these additional insureds, the following is added to **Section III – Limits Of Insurance:**

If coverage provided to the additional insured is required by a contract or agreement, the most we will pay on behalf of the additional insured is the amount of insurance:

1. Required by the contract or agreement; or

2. Available under the applicable limits of insurance;
whichever is less.

This endorsement shall not increase the applicable limits of insurance.

Workers' Compensation and Employers' Liability Policy

Named Insured Riverside Construction Company, Inc.	Endorsement Number
	Policy Number: 54309464
Policy Period 07/01/2023 TO 07/01/2024	Effective Date of Endorsement 07/01/2023
Issued By (Name of Insurance Company) Federal Insurance Company	
Insert the policy number. The remainder of the information is to be completed only when this endorsement is issued subsequent to the preparation of the policy.	

CALIFORNIA WAIVER OF OUR RIGHT TO RECOVER FROM OTHERS ENDORSEMENT

This endorsement applies only to the insurance provided by the policy because California is shown in Item 3.A. of the Information Page.

We have the right to recover our payments from anyone liable for an injury covered by this policy. We will not enforce our right against the person or organization named in the Schedule, but this waiver applies only with respect to bodily injury arising out of the operations described in the Schedule, where you are required by a written contract to obtain this waiver from us.

You must maintain payroll records accurately segregating the remuneration of your employees while engaged in the work described in the Schedule.

Schedule

1. () Specific Waiver
Name of person or organization:

(X) Blanket Waiver
Any person or organization for whom the Named Insured has agreed by written contract to furnish this waiver.
2. Operations:
ALL
3. Premium:
The premium charge for this endorsement shall be 1.0 percent of the California premium developed on payroll in connection with work performed for the above person(s) or organization(s) arising out of the operations described.
4. Minimum Premium: \$0



Authorized Representative

THIS ENDORSEMENT CHANGES THE POLICY. PLEASE READ IT CAREFULLY.

ADDITIONAL INSURED – OWNERS, LESSEES OR CONTRACTORS – COMPLETED OPERATIONS

This endorsement modifies insurance provided under the following:

COMMERCIAL GENERAL LIABILITY COVERAGE PART
 PRODUCTS/COMPLETED OPERATIONS LIABILITY COVERAGE PART

SCHEDULE

Name Of Additional Insured Person(s) Or Organization(s)	Location And Description Of Completed Operations
WHERE REQUIRED BY WRITTEN CONTRACT, BUT ONLY WHEN THE CONTRACT SPECIFIES COVERAGE FOR COMPLETED OPERATIONS	ALL LOCATIONS WHERE REQUIRED BY WRITTEN CONTRACT
Information required to complete this Schedule, if not shown above, will be shown in the Declarations.	

A. Section II – Who Is An Insured is amended to include as an additional insured the person(s) or organization(s) shown in the Schedule, but only with respect to liability for "bodily injury" or "property damage" caused, in whole or in part, by "your work" at the location designated and described in the Schedule of this endorsement performed for that additional insured and included in the "products-completed operations hazard".

However:

1. The insurance afforded to such additional insured only applies to the extent permitted by law; and
2. If coverage provided to the additional insured is required by a contract or agreement, the insurance afforded to such additional insured will not be broader than that which you are required by the contract or agreement to provide for such additional insured.

B. With respect to the insurance afforded to these additional insureds, the following is added to **Section III – Limits Of Insurance:**

If coverage provided to the additional insured is required by a contract or agreement, the most we will pay on behalf of the additional insured is the amount of insurance:

1. Required by the contract or agreement; or
 2. Available under the applicable Limits of Insurance shown in the Declarations;
- whichever is less.

This endorsement shall not increase the applicable Limits of Insurance shown in the Declarations.



54309463

COMMERCIAL AUTOMOBILE

THIS ENDORSEMENT CHANGES THE POLICY. PLEASE READ IT CAREFULLY.

COMMERCIAL AUTOMOBILE BROAD FORM ENDORSEMENT

This endorsement modifies insurance provided under the following:

BUSINESS AUTO COVERAGE FORM

This endorsement modifies the Business Auto Coverage Form.

1. EXTENDED CANCELLATION CONDITION

Paragraph A.2.b. – CANCELLATION - of the COMMON POLICY CONDITIONS form IL 00 17 is deleted and replaced with the following:

- b. 60 days before the effective date of cancellation if we cancel for any other reason.

2. BROAD FORM INSURED

A. Subsidiaries and Newly Acquired or Formed Organizations As Insureds

The Named Insured shown in the Declarations is amended to include:

- 1. Any legally incorporated subsidiary in which you own more than 50% of the voting stock on the effective date of the Coverage Form. However, the Named Insured does not include any subsidiary that is an "insured" under any other automobile policy or would be an "insured" under such a policy but for its termination or the exhaustion of its Limit of Insurance.
- 2. Any organization that is acquired or formed by you and over which you maintain majority ownership. However, the Named Insured does not include any newly formed or acquired organization:
 - (a) That is an "insured" under any other automobile policy;
 - (b) That has exhausted its Limit of Insurance under any other policy; or
 - (c) 180 days or more after its acquisition or formation by you, unless you have given us written notice of the acquisition or formation.

Coverage does not apply to "bodily injury" or "property damage" that results from an "accident" that occurred before you formed or acquired the organization.

B. Employees as Insureds

Paragraph A.1. – WHO IS AN INSURED – of SECTION II – LIABILITY COVERAGE is amended to add the following:

- d. Any "employee" of yours while using a covered "auto" you don't own, hire or

borrow in your business or your personal affairs.

C. Lessors as Insureds

Paragraph A.1. – WHO IS AN INSURED – of SECTION II – LIABILITY COVERAGE is amended to add the following:

- e. The lessor of a covered "auto" while the "auto" is leased to you under a written agreement if:
 - (1) The agreement requires you to provide direct primary insurance for the lessor; and
 - (2) The "auto" is leased without a driver. Such leased "auto" will be considered a covered "auto" you own and not a covered "auto" you hire.
 However, the lessor is an "insured" only for "bodily injury" or "property damage" resulting from the acts or omissions by:
 - 1. You;
 - 2. Any of your "employees" or agents; or
 - 3. Any person, except the lessor or any "employee" or agent of the lessor, operating an "auto" with the permission of any of 1. and/or 2. above.

D. Persons And Organizations As Insureds Under A Written Insured Contract

Paragraph A.1 – WHO IS AN INSURED – of SECTION II – LIABILITY COVERAGE is amended to add the following:

- f. Any person or organization with respect to the operation, maintenance or use of a covered "auto", provided that you and such person or organization have agreed under an express provision in a written "insured contract", written agreement or a written permit issued to you by a governmental or public authority to add such person or organization to this policy as an "insured". However, such person or organization is an "insured" only:

- (1) with respect to the operation, maintenance or use of a covered "auto"; and
- (2) for "bodily injury" or "property damage" caused by an "accident" which takes place after:
 - (a) You executed the "insured contract" or written agreement; or
 - (b) The permit has been issued to you.

3. FELLOW EMPLOYEE COVERAGE

EXCLUSION B.5. - FELLOW EMPLOYEE - of SECTION II - LIABILITY COVERAGE does not apply.

4. PHYSICAL DAMAGE - ADDITIONAL TEMPORARY TRANSPORTATION EXPENSE COVERAGE

Paragraph A.4.a. - TRANSPORTATION EXPENSES - of SECTION III - PHYSICAL DAMAGE COVERAGE is amended to provide a limit of \$50 per day for temporary transportation expense, subject to a maximum limit of \$1,000.

5. AUTO LOAN/LEASE GAP COVERAGE

Paragraph A. 4. - COVERAGE EXTENSIONS - of SECTION III - PHYSICAL DAMAGE COVERAGE is amended to add the following:

c. Unpaid Loan or Lease Amounts

In the event of a total "loss" to a covered "auto", we will pay any unpaid amount due on the loan or lease for a covered "auto" minus:

1. The amount paid under the Physical Damage Coverage Section of the policy; and
2. Any:
 - a. Overdue loan/lease payments at the time of the "loss";
 - b. Financial penalties imposed under a lease for excessive use, abnormal wear and tear or high mileage;
 - c. Security deposits not returned by the lessor;
 - d. Costs for extended warranties, Credit Life Insurance, Health, Accident or Disability Insurance purchased with the loan or lease; and
 - e. Carry-over balances from previous loans or leases.

We will pay for any unpaid amount due on the loan or lease if caused by:

1. Other than Collision Coverage only if the Declarations indicate that Comprehensive Coverage is provided for any covered "auto";
2. Specified Causes of Loss Coverage only if the Declarations indicate that Specified Causes of Loss Coverage is provided for any covered "auto"; or
3. Collision Coverage only if the Declarations indicate that Collision Coverage is provided for any covered "auto".

6. RENTAL AGENCY EXPENSE

Paragraph A. 4. - COVERAGE EXTENSIONS - of SECTION III - PHYSICAL DAMAGE COVERAGE is amended to add the following:

d. Rental Expense

We will pay the following expenses that you or any of your "employees" are legally obligated to pay because of a written contract or agreement entered into for use of a rental vehicle in the conduct of your business:

MAXIMUM WE WILL PAY FOR ANY ONE CONTRACT OR AGREEMENT:

1. \$2,500 for loss of income incurred by the rental agency during the period of time that vehicle is out of use because of actual damage to, or "loss" of, that vehicle, including income lost due to absence of that vehicle for use as a replacement;
 2. \$2,500 for decrease in trade-in value of the rental vehicle because of actual damage to that vehicle arising out of a covered "loss"; and
 3. \$2,500 for administrative expenses incurred by the rental agency, as stated in the contract or agreement.
 4. \$7,500 maximum total amount for paragraphs 1., 2. and 3. combined.
- 7. EXTRA EXPENSE - BROADENED COVERAGE**
Paragraph A.4. - COVERAGE EXTENSIONS - of SECTION III - PHYSICAL DAMAGE COVERAGE is amended to add the following:

e. Recovery Expense

We will pay for the expense of returning a stolen covered "auto" to you.

8. AIRBAG COVERAGE

Paragraph B.3.a. - EXCLUSIONS - of SECTION III - PHYSICAL DAMAGE COVERAGE does not apply to the accidental or unintended discharge of an airbag. Coverage is excess over any other collectible insurance or warranty specifically designed to provide this coverage.

9. AUDIO, VISUAL AND DATA ELECTRONIC EQUIPMENT - BROADENED COVERAGE

Paragraph C.1.b. - LIMIT OF INSURANCE - of SECTION III - PHYSICAL DAMAGE is deleted and replaced with the following:

- b. \$2,000 is the most we will pay for "loss" in any one "accident" to all electronic equipment that reproduces, receives or transmits audio, visual or data signals which, at the time of "loss", is:
 - (1) Permanently installed in or upon the covered "auto" in a housing, opening or other location that is not normally used by the "auto" manufacturer for the installation of such equipment;
 - (2) Removable from a permanently installed housing unit as described in Paragraph 2.a. above or is an integral part of that equipment; or
 - (3) An integral part of such equipment.

10. GLASS REPAIR - WAIVER OF DEDUCTIBLE

Under Paragraph D. - DEDUCTIBLE – of SECTION III – PHYSICAL DAMAGE COVERAGE the following is added:

No deductible applies to glass damage if the glass is repaired rather than replaced.

11. TWO OR MORE DEDUCTIBLES

Paragraph D.- DEDUCTIBLE – of SECTION III – PHYSICAL DAMAGE COVERAGE is amended to add the following:

If this Coverage Form and any other Coverage Form or policy issued to you by us that is not an automobile policy or Coverage Form applies to the same "accident", the following applies:

1. If the deductible under this Business Auto Coverage Form is the smaller (or smallest) deductible, it will be waived; or
2. If the deductible under this Business Auto Coverage Form is not the smaller (or smallest) deductible, it will be reduced by the amount of the smaller (or smallest) deductible.

12. AMENDED DUTIES IN THE EVENT OF ACCIDENT, CLAIM, SUIT OR LOSS

Paragraph A.2.a. - DUTIES IN THE EVENT OF AN ACCIDENT, CLAIM, SUIT OR LOSS of SECTION IV - BUSINESS AUTO CONDITIONS is deleted and replaced with the following:

- a. In the event of "accident", claim, "suit" or "loss", you must promptly notify us when the "accident" is known to:
 - (1) You or your authorized representative, if you are an individual;
 - (2) A partner, or any authorized representative, if you are a partnership;
 - (3) A member, if you are a limited liability company; or
 - (4) An executive officer, insurance manager, or authorized representative, if you are an organization other than a partnership or limited liability company.

Knowledge of an "accident", claim, "suit" or "loss" by other persons does not imply that the persons listed above have such knowledge.

Notice to us should include:

- (1) How, when and where the "accident" or "loss" occurred;
- (2) The "insured's" name and address; and
- (3) To the extent possible, the names and addresses of any injured persons or witnesses.

13. WAIVER OF SUBROGATION

Paragraph A.5. - TRANSFER OF RIGHTS OF RECOVERY AGAINST OTHERS TO US of SECTION IV – BUSINESS AUTO CONDITIONS is deleted and replaced with the following:

5. We will waive the right of recovery we would otherwise have against another person or organization for "loss" to which this insurance applies, provided the "insured" has waived

their rights of recovery against such person or organization under a contract or agreement that is entered into before such "loss".

To the extent that the "insured's" rights to recover damages for all or part of any payment made under this insurance has not been waived, those rights are transferred to us. That person or organization must do everything necessary to secure our rights and must do nothing after "accident" or "loss" to impair them. At our request, the insured will bring suit or transfer those rights to us and help us enforce them.

14. UNINTENTIONAL FAILURE TO DISCLOSE HAZARDS

Paragraph B.2. – CONCEALMENT, MISREPRESENTATION or FRAUD of SECTION IV – BUSINESS AUTO CONDITIONS - is deleted and replaced with the following:

If you unintentionally fail to disclose any hazards existing at the inception date of your policy, we will not void coverage under this Coverage Form because of such failure.

15. AUTOS RENTED BY EMPLOYEES

Paragraph B.5. - OTHER INSURANCE of SECTION IV – BUSINESS AUTO CONDITIONS - is amended to add the following:

- e. Any "auto" hired or rented by your "employee" on your behalf and at your direction will be considered an "auto" you hire. If an "employee's" personal insurance also applies on an excess basis to a covered "auto" hired or rented by your "employee" on your behalf and at your direction, this insurance will be primary to the "employee's" personal insurance.

16. HIRED AUTO – COVERAGE TERRITORY

Paragraph B.7.b.(5). - POLICY PERIOD, COVERAGE TERRITORY of SECTION IV – BUSINESS AUTO CONDITIONS is deleted and replaced with the following:

- (5) A covered "auto" of the private passenger type is leased, hired, rented or borrowed without a driver for a period of 45 days or less; and

17. RESULTANT MENTAL ANGUISH COVERAGE

Paragraph C. of - SECTION V – DEFINITIONS is deleted and replaced by the following:

"Bodily injury" means bodily injury, sickness or disease sustained by any person, including mental anguish or death as a result of the "bodily injury" sustained by that person.





MEMO

To:	Whom it may concern		
From:	Anthony D'Asaro		
Named Insured(s):	Riverside Construction Company, Inc.		
Policy Number(s):	54309745 54309464	54309463 72CPIBB6808	03138983
RE:	Notice of Cancellation		

Certificate Holder Name & Address	County of Riverside Transportation Department Attn: Contracts & Bidding Unit 3525 14th Street Riverside CA 92501
----------------------------------------------	------------------------------------------------------------------------------------------------------------------------------

Should the above described policy be cancelled before the expiration date thereof, change in coverage or reduction of limits, we will mail 30 days written notice to the Certificate Holder named above; except, 10 days notice for non-payment of premium.

Sincerely,

4/11/2024
Managing Principal
(949) 417-9170

19000 MacArthur Blvd., PH • Irvine, CA 92612
P: 949.263.0606 • F: 949.263.0906 • CA License 0B29370
www.edgewoodins.com

- Company Profile
- Company Search
- Company Search Results
- Company Information
- Old Company Names
- Agent for Service Reference Information
- NAIC Group List
- Lines of Business
- Workers' Compensation
- Complaint and Request for Action/Appeals
- Contact Information
- Financial Statements PDF's
 - Annual Statements
 - Quarterly Statements
- Company Complaint
- Company Performance & Comparison Data
- Company Enforcement Action
- Composite Complaints Studies
- Additional Info
 - Find A Company Representative In Your Area
 - View Financial Disclaimer

COMPANY PROFILE

Company Information

FEDERAL INSURANCE COMPANY
202B HALL'S MILL ROAD
WHITEHOUSE STATION, NJ 08889
800-252-4670

Old Company Names **Effective Date**

Agent For Service

AMANDA GARCIA
 330 N Brand Blvd Ste 700
 Glendale CA 91203

Reference Information

NAIC #:	20281
California Company ID #:	0059-6
Date Authorized in California:	12/18/1902
License Status:	UNLIMITED-NORMAL
Company Type:	Property & Casualty
State of Domicile:	INDIANA

[back to top](#)

NAIC Group List

NAIC Group #: 0626 Chubb Ltd Grp

Lines Of Business

The company is authorized to transact business within these lines of insurance. For an explanation of any of these terms, please refer to the [glossary](#).

- AIRCRAFT
- AUTOMOBILE
- BOILER AND MACHINERY
- BURGLARY
- COMMON CARRIER LIABILITY
- CREDIT
- DISABILITY
- FIRE
- LIABILITY
- MARINE
- MISCELLANEOUS
- PLATE GLASS
- SPRINKLER
- SURETY
- TEAM AND VEHICLE
- WORKERS' COMPENSATION

[back to top](#)

SPECIFICATIONS and CONTRACT DOCUMENTS
for the
CONSTRUCTION
of

Emergency Road and Storm Drain Damage Repair Work
Pedley Road, Emergency Access Road
Western Riverside County/City Animal Shelter
Project No. D4-0135



TRANSPORTATION DEPARTMENT

FORM APPROVED COUNTY COUNSEL
BY: 
DANIELLE D. MALAND

General

Table of Contents

<u>Description</u>	<u>Page</u>
Vicinity Map	i
Instructions to Contractors	A1 – A6
Subcontractor List	B1
Contract and other Bonds	
Contract	C1 – C3
Performance Bond	C4
Payment Bond	C5
General Conditions*	GC1 – GC33
Special Provisions*	1 – 36
Appendices	
AQMD Recommendations*	Appendix A
RCP and Headwall Sketch	Appendix B

* **Note:** See the first page of this document description for a detailed Table of Contents.

COUNTY OF RIVERSIDE TRANSPORTATION DEPARTMENT

Emergency Road and Storm Drain Damage Repair Work

Pedley Road, Emergency Access Road

Western Riverside County/City Animal Shelter

PROJECT No. D4-0135

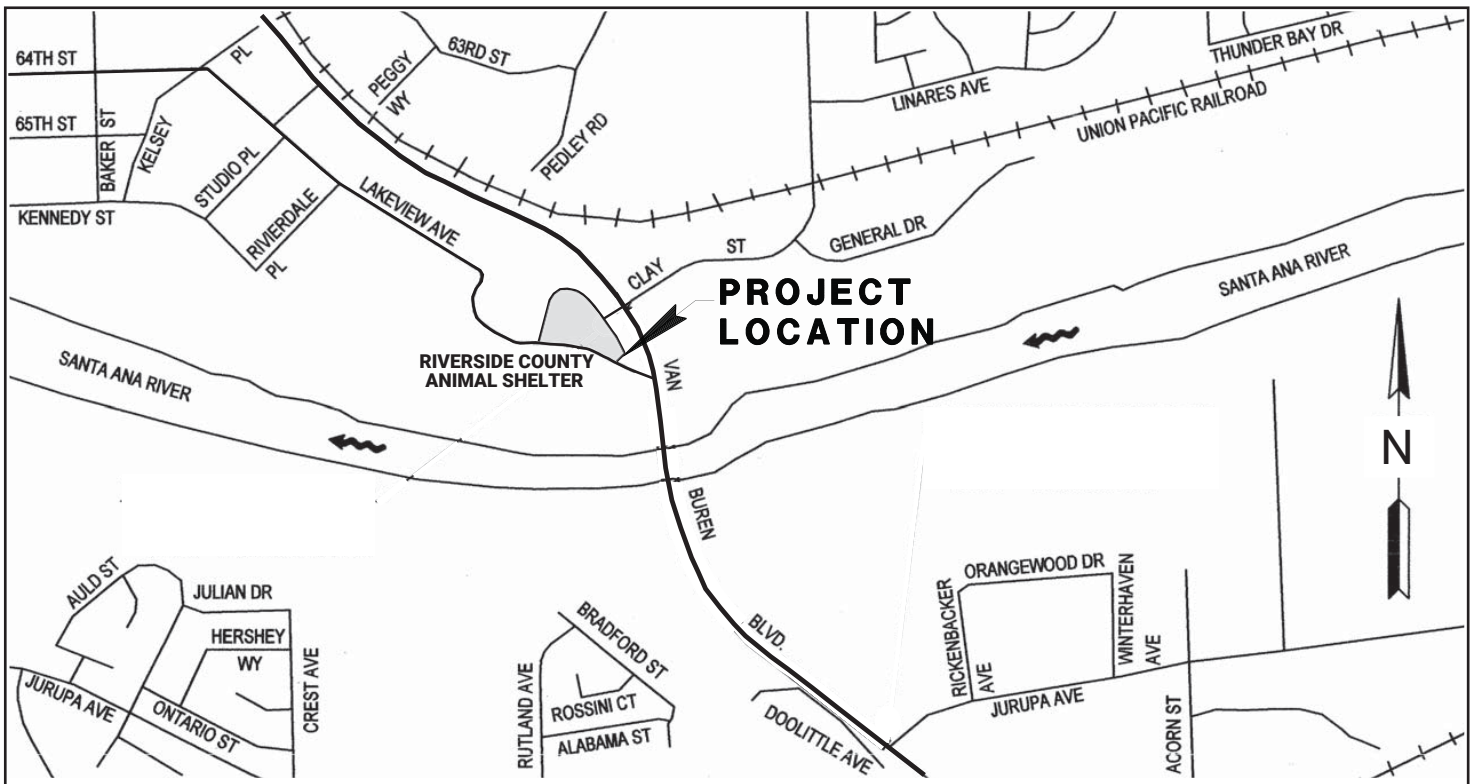
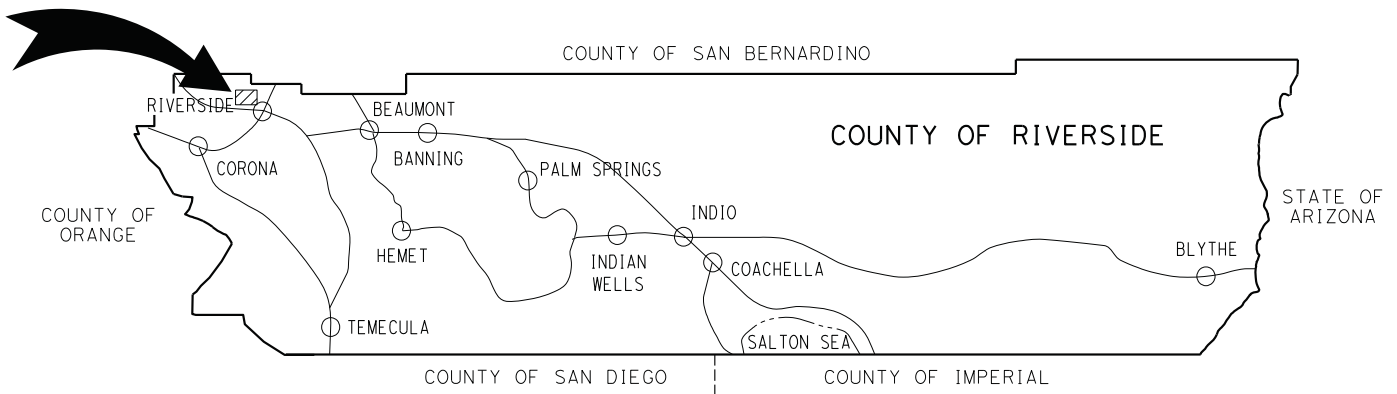

VICINITY MAP

Instructions to Contractors (Emergency Work)

Table of Contents

- 1. Inspection of Site A 2
- 2. License A 2
- 3. Contract Participation A 3
- 4. Subletting, Subcontracting, and Subcontractor List A 3
- 5. Registration with the Department of Industrial Relations (DIR)..... A 4
- 6. Hours of Work A 5
- 7. Contract Documents..... A 5
- 8. Qualifications of Contractors A 5
- 9. Award of Contract..... A 5
- 10. Payment and Performance Bonds A 6
- 11. Submission of Insurance Certificate and Endorsements..... A 6

Instructions to Contractors (Emergency Work)

In compliance with the Americans with Disabilities Act, persons with disabilities may request reasonable accommodations (including auxiliary aids and services at no cost) to participate in Emergency Work by contacting Contracts/Bidding Unit at 951-955-6780 or jrjimenez@rivco.org at least 3 business days before the scheduled submittal date of Emergency Work cost estimate.

In compliance with Title II of the Americans with Disabilities Act (ADA), the County of Riverside does not discriminate on the basis of disability in admission to, access to, or operations of its programs, services or activities. It is committed to ensuring that its programs, services and activities are fully accessible to and usable by people with disabilities.

To accommodate persons with disabilities, this Specifications and Contract Documents Book is available in alternate formats upon request.

1. Inspection of Site

Contractor's attention is directed to Standard Specifications Section 2-1.07, "Job Site and Document Examination." Contractors must examine the site and acquaint themselves with all conditions affecting the work. By making and submitting a cost estimate, a Contractor warrants that he has made such site examination as the Contractor deems necessary for the condition of the site, its accessibility for materials, workmen and utilities, and for the ability to protect existing surface and subsurface improvements. No claim for allowances, time or money, will be allowed as to such matters.

2. License

Contractor must have the necessary license(s) required under provisions of the California Business and Professions Code for the scope of work covered in the Contract Documents at the time of cost estimate submission. This includes Joint Ventures.

Each item of work will be performed by a Contractor that is qualified and properly licensed for that work.

Pursuant to California Labor Code §3099, certification is required for all persons who perform work as electricians for Contractors licensed as Class C10 "Electrical Contractor." Proof of certification must be provided to the County before the start of construction.

3. Contract Participation

County encourages general and prime Contractors to solicit competitive subcontracting, trucking and supplier opportunities to minority, women, disabled veteran, and small business firms where possible, in their contracting and procurement activities with the County.

Section 3-1.08, “Small Business Participation Report,” of the Standard Specifications is deleted.

4. Subletting, Subcontracting, and Subcontractor List

General

Attention is directed to General Conditions Section 12, “Subcontracting”.

Pursuant to Public Contract Code § 4100 et seq., “Subletting and Subcontracting Fair Practices Act,” Contractors are required to list each subcontractor who will perform work, provide labor, or render services in or about the construction of work or improvement or a subcontractor who specifically fabricates and installs a portion of the work or improvement according to the details contained in the Plans and Specifications. The Subletting and Subcontracting Fair Practice Act applies to all phases of the work.

Subcontractor List

The Contractor must submit a Subcontractor List when subcontracting is utilized. Subcontractor List must be on the form contained in the Specifications and Contract Documents Book.

Section 2-1.10, “Subcontractor List” of the Standard Specifications is deleted and replaced with the following:

Contractor must list each subcontractor to perform work, labor or render service in or about the construction in an amount in excess of 1/2 of 1 percent of the total Contract amount or \$10,000, whichever is greater (Public Contract Code § 4100 et seq.).

Pursuant to Public Contract Code § 6109 et seq., the Contractor shall not perform work on a project with a subcontractor who is ineligible to perform work on the project pursuant to Labor Code § 1777.1 or 1777.7.

The Subcontractor List must show the business name, business address, license number, DIR registration number and work portions to be performed by each subcontractor listed. Work portions must be identified by description for each subcontractor listed. The percentage of work to be performed by all listed subcontractors must be written on the bottom of the Subcontractor List form.

An inadvertent error in listing the license number will be processed as required by Public Contract Code § 4104 (a) (2). If partial work is to be performed within a certain construction item or trade, the Contractor shall specify the portions of the work to be performed by the different subcontractors or the directive under Public Contract Code § 4106 shall apply.

Each designated item of work will be performed by a Contractor who is qualified and properly licensed for that listed item of work.

Omission or failure to list a subcontractor for a portion of the work means that the prime Contractor will do that portion of the work (Public Contract Code § 4106).

The County may request additional information to verify submitted Subcontractor List information and for total and/or individual subcontracted percentage amounts. Contractor must provide this information within three (3) business days after the cost estimate submittal due date.

Penalties

The Contractor's attention is directed to other provisions of the Subletting and Subcontracting Fair Practices Act related to the imposition of penalties for failure to observe its provisions by utilizing unauthorized subcontractors or by making unauthorized substitutions.

Clerical error

After the cost estimate submission and prior to award of Contract, inadvertent subcontractor designation clerical error(s) will be processed as required by Public Contract Code § 4107.5 and as required by Labor Code § 1771.1 (c) for subcontractors who are not registered with the DIR.

5. Registration with the Department of Industrial Relations (DIR)

Attention is directed to:

- General Conditions Section 8, "Labor Code"

No Contractor may submit a cost estimate nor a subcontractor be listed on a cost estimate (submitted on or after March 1, 2015) unless registered with the Department of Industrial Relations pursuant to Labor Code § 1725.5 or excepted from this requirement for bid purposes only under Labor Code § 1771.1(a).

No Contractor or subcontractor may be awarded a Contract (awarded on or after April 1, 2015) or perform work on any contract for public work unless registered with the Department of Industrial Relations pursuant to Labor Code section 1725.5.

This project is subject to compliance monitoring and enforcement by the DIR.

6. Hours of Work

Attention is directed to Section 8-1.05, "Time" and Section 7-1.02K(5), "Working Hours" of the Standard Specifications.

Daily working hours will be between the hours of **7:00 a.m. and 6:00 p.m.**, Monday through Friday, except County-overserved holidays, or as revised in the Special Provisions, and as approved by the Engineer. Exceptions and specific work schedules must be submitted in writing to the Engineer for consideration.

7. Contract Documents

The complete Contract Documents are identified in the Contract. Contractors are cautioned that the successful Contractor incurs duties and obligations under all of the Contract Documents and that they should not merely skim and hastily review the Plans and Specifications (if any) in making their cost estimate.

8. Qualifications of Contractors

No award will be made to any Contractor who cannot give satisfactory assurance to the Board of Supervisors as to his own ability to carry out the Contract, both from his financial standing and by reason of his previous experience as a Contractor on work of the nature contemplated in the Contract. The Contractor may be required to submit his record of work of similar nature to that proposed under these specifications and unfamiliarity with the type of work may be sufficient cause for rejection of cost estimate.

9. Award of Contract

The Contractor's attention is directed to the provisions in these Instructions to Contractors for the requirements and conditions concerning award and execution of Contract.

Section 3-1.04, "Contract Award" of the Standard Specifications is deleted.

The Emergency Contract can be executed in accordance with authority that the Board has delegated to the Director of Transportation by Resolution No. 93-047, now as adopted by Resolution No. 2019-035 (January 29, 2019; agenda item 3.24), and has been approved as to legal form by County Counsel.

Resolution No. 93-047, adopted March 30, 1993, which states that emergency contracts to safe guard life, health or property can be authorized by the Director of Transportation. The resolution requires that the Director of Transportation report back to the Board in a public meeting after executing the Contract.

This work is being performed in accordance with the Force Account provisions of the Standard Specifications and as detailed in the Contract.

10. Payment and Performance Bonds

The County requires a 100% Payment Bond and 100% Performance Bond from the successful Contractor. All bonds must be on County's forms contained in the Specifications and Contract Documents Book.

The bonds must be underwritten by a Surety Company, which is admitted to transact the business of insurance in the State of California, and which carries a rating in the current issue of Best's Insurance Guide of "A" or better with a financial size of at least "VIII". If a California admitted surety issuing bonds does not meet these requirements, the surety will be considered qualified if it is in conformance with Section 995.660 of the California Code of Civil Procedure, and proof of such is provided to the County. The bond forms included in the Specifications and Contract Documents Book must be used. All signatures on the bonds must be notarized. Bonds must be provided with an executed Power of Attorney issued by the Surety.

11. Submission of Insurance Certificate and Endorsements

Attention is directed General Conditions Section 4 "Insurance and Hold Harmless."

Within five (5) working days of the date of the Notice to Proceed issued by the County and prior to the commencement of work, the selected Contractor must submit a certificate of insurance, including required endorsements, which provides evidence that the Contractor has insurance coverage that meets the requirements of General Conditions "Insurance and Hold Harmless" section. Failure to have complete insurance coverage in place and to provide all required certificates and endorsements within the specified five (5) business day period will be grounds to declare the Contractor as non-compliant with the Contract Documents, rescinding the Notice of Acceptance and awarding to the second low bidding Contractor, at the sole discretion of the County.

Subcontractor List

Bidder/Contractor submits the following complete list of each Subcontractor who will perform work, labor or render service in or about the construction in an amount in excess of 1/2 of 1% of the total bid or \$10,000 whichever is greater.

Check box on right side of row if any construction item, for the listed Subcontractor, is partial work. If partial work is to be performed within a certain construction item or trade, the Bidder/Contractor shall specify the portion(s) of the work to be performed by the different subcontractors or Bidder/Contractor will be subject to provisions of Public Contract Code Section 4106.

Name of Bidder (Prime/General Contractor): _____

	Subcontractor Name	License Number	DIR Registration Number	Business Address (City, State)	Construction Item(s) [Item Number and Description]	Check if Partial Work
1.						<input type="checkbox"/>
2.						<input type="checkbox"/>
3.						<input type="checkbox"/>
4.						<input type="checkbox"/>
5.						<input type="checkbox"/>
6.						<input type="checkbox"/>

Additional Subcontractor List(s) may be attached to the Bid.
(A copy of this form may be attached with additional Subcontractor information.)

Percent of work to be performed by Subcontractors: _____%

Note: A minimum of 50% of the work is required to be performed by the prime/general Contractor.

Contract

THIS CONTRACT is entered into at Riverside, California as of the date set forth below is between County of Riverside hereafter called "County" and **Riverside Construction Company, Inc.**, hereafter called "Contractor".

W I T N E S S E T H

Recitals:

1. Contractor has submitted to County his Contractor's Proposal for the construction of County Project, **Emergency Road and Storm Drain Damage Repair Work, Pedley Road, Emergency Access Road, Western Riverside County/City Animal Shelter, Project No. D4-0135**, in strict accordance with the Contract Documents identified below and County has accepted said Proposal.
2. Contractor states that he has reexamined his Contractor's Proposal and found it to be correct, has ascertained that his subcontractors are properly licensed and possess the requisite skill and forces, has reexamined the site and Contract Documents and is of the opinion that he can presently do the work in accordance with the Contract Documents for the money set forth in his Proposal to be paid as provided in the Contract Documents.

Agreement:

It is agreed by the parties as follows:

1. Contract Documents

The entire Contract consists of the following: (a) The Construction Contract, (b) The Bid, (c) The Payment Bond, (d) The Performance Bond, (e) The General Conditions, (f) The Special Provisions, (g) The Standard Specifications of the State of California Department of Transportation edition of **2018** as modified in other portions of the Contract Documents and as amended by the State of California Department of Transportation, (h) The Standard Plans of the Department of Transportation identified on the plans or in the Special Provisions, (i) The Plans, (j) The Determination of Prevailing Wage Rates for Public Works, (k) Any Change Orders issued, and (l) Any additional or supplemental specifications, notice, instructions and drawings issued in accordance with the provisions of the Contract Documents. All of said Documents presently in existence are by this reference incorporated herein with like effect as if here set forth in full and upon the proper issuance of other documents they shall likewise be deemed incorporated. The Bid Bond is exonerated upon execution of this Contract and the Payment Bond and Performance Bond.

2. The Work

Contractor shall do all emergency repairs necessary to construct the work generally described in Recital No. 1 and Special Provisions in accordance with the Contract Documents.

3. Prosecution, Progress and Liquidated Damages

Attention is directed to the provisions in Section 8-1.04, "Start of Job Site Activities", Section 8-1.05, "Time", and in Section 8-1.10 "Liquidated Damages" of the Standard Specifications and these Special Provisions.

Standard Specification Section 8-1.04B, "Standard Start" is modified to read as follows:

The Contractor shall begin work within **two (2) calendar days**, or as revised in the Special Provisions, of the date stated within the written "Notice to Proceed".

The Contractor shall notify the Engineer, in writing, of the Contractor's intent to begin work **at least 24 hours before work** is begun. If the project has more than one (1) location of work, Contractor shall submit a separate notice for each location. The notice shall be delivered to the Transportation Department's Construction Engineer and shall specify the date the Contractor intends to start at said location.

Should the Contractor begin work in advance of receiving a written "Notice to Proceed", any work performed by the Contractor in advance of the date stated in the "Notice to Proceed" shall be considered as having been done by the Contractor at his own risk and as a volunteer and subject to the following:

- A. The Contractor shall, on commencing operations, take all precautions required for public safety and shall observe all the provisions in the Specifications and the Special Provisions.
- B. All work done according to the Contract, prior to the issuance of the "Notice to Proceed", will be considered authorized work and will be paid for as provided in the contract.
- C. The Contractor shall not be entitled to any additional compensation or an extension of time for any delay, hindrance or interference caused by or attributable to commencement of work prior to the issuance of the "Notice to Proceed".

4. Compensation

The Contractor agrees to receive and accept payment, on a force-account basis, as full compensation for furnishing all materials and for doing all the work contemplated and embraced in this Contract, until its acceptance by the County of Riverside, and for well and faithfully completing the work, and the whole thereof, in the manner according to the specifications, and the requirements of the Engineer.

The estimated cost for this project, prior to commencement of work, is **\$500,000.00 (Five hundred thousand dollars and zero cents)**.

**Emergency Road and Storm Drain Damage Repair Work
Pedley Road, Emergency Access Road
Western Riverside County/City Animal Shelter
Project No. D4-0135**

IN WITNESS WHEREOF the parties hereto have executed this Contract as of the date set forth below.

COUNTY OF RIVERSIDE

RIVERSIDE CONSTRUCTION COMPANY, INC.

BY: _____

BY: _____

Dennis Acuna
Director of Transportation
*Delegated authority for emergency contracts per
Resolution No. 93-047, currently adopted by
Resolution No. 2019-035 (January 29, 2019;
Agenda Item 3.24)*

TITLE: _____
(If Corporation, affix Seal)

DATED: _____

ATTEST:

TITLE: _____

Licensed in accordance with an act providing
for the registration of Contractors,

License No.: 266222

Federal Employer Identification Number:
95-2662331

Department of Industrial Relations Registration Number:
1000003993

"Corporation"
(Seal)

Performance Bond

Recitals:

1. **Riverside Construction Company, Inc.** (Contractor) has entered into a Contract with COUNTY OF RIVERSIDE (County) for construction of public work known as **Emergency Road and Storm Drain Damage Repair Work, Pedley Road, Emergency Access Road, Western Riverside County/City Animal Shelter, Project No. D4-0135.**

2. _____, a _____ corporation (Surety), is the Surety under this Bond.

Agreement:

We, Contractor as Principal and Surety as Surety, jointly and severally agree, state, and are bound unto County, as obligee, as follows:

1. The amount of the obligation of this Bond is 100% of the estimated contract price for the Project of **\$500,000.00 (Five hundred thousand dollars and zero cents)** and inures to the benefit of County.

2. This Bond is exonerated by Contractor doing all things to be kept and performed by it in strict conformance with the Contract Documents for this project, otherwise it remains in full force and effect for the recovery of loss, damage and expense of County resulting from failure of Contractor to so act. All of said Contract Documents are incorporated herein.

3. This obligation is binding on our successors and assigns.

4. For value received, Surety stipulates and agrees that no change, time extension, prepayment to Contractor, alteration or addition to the terms and requirements of the Contract Documents or the work to be performed thereunder shall affect its obligations hereunder and waives notice as to such matters, except the total contract price cannot be increased by more than 10% without approval of Surety.

THIS BOND is executed as of _____.

By _____

By _____

By _____

Type Name _____

Its Attorney in Fact
"Surety"

Title _____

"Contractor"

(Corporate Seal)

(Corporate Seal)

NOTE: This Bond must be executed by both parties with corporate seal affixed. All signatures must be acknowledged. (Attach acknowledgements).

Payment Bond

(Public Works - Civil Code §9550 et seq.)

The makers of this Bond are **Riverside Construction Company, Inc.**, as Principal and Original Contractor and _____, a corporation, authorized to issue Surety Bonds in California, as Surety, and this Bond is issued in conjunction with that certain public works contract to be executed between Principal and COUNTY OF RIVERSIDE a public entity, as Owner, for **\$500,000.00 (Five hundred thousand dollars and zero cents)**, the total amount payable. The amount of this bond is one hundred percent (100%) of said sum. Said contract is for public work generally consisting of **Emergency Road and Storm Drain Damage Repair Work, Pedley Road, Emergency Access Road, Western Riverside County/City Animal Shelter, Project No. D4-0135.**

The beneficiaries of this Bond are as is stated in 9554 of the Civil Code and requirements and conditions of this Bond are as is set forth in 9554, 9558, 9560 and 9564 of said code. Without notice, Surety consents to extension of time for performance, change in requirements, amount of compensation, or prepayment under said contract.

Dated: _____

Original Contractor – Principal

Surety

By _____

By _____

Title _____

Its Attorney In Fact

(If corporation, affix seal)

(Corporate Seal)

(Corporate Seal)

STATE
OF _____
COUNTY
OF _____

} ss. SURETY'S ACKNOWLEDGEMENT

On _____ before me, _____ personally appeared, _____, known to me, or proved to me on the basis of satisfactory evidence, to be the person whose name is subscribed to the within instrument and acknowledged to me that he executed the same in his authorized capacities, and that by his signature on the instrument the person, or the entity upon behalf of which the person acted, executed the instrument.

WITNESS my hand and official seal.

Signature of Notary Public

Notary Public (Seal)

NOTE: This Bond must be executed by both parties with corporate seal affixed. All signatures must be acknowledged. (Attach acknowledgements).

General Conditions

Table of Contents

1. Definitions and Terms.....GC 3

2. Standard Specifications.....GC 4

3. Director of Transportation and Land Management Agency (TLMA).....GC 5

4. Insurance and Hold Harmless.....GC 6

5. Beginning of Work, Time of Completion, and Liquidated Damages.....GC 10

6. County’s Right to Stop Work or Terminate the Contract.....GC 11

7. General Prevailing Wage:.....GC 11

8. Labor Code.....GC 12

9. Labor Nondiscrimination.....GC 13

10. Title VI Nondiscrimination.....GC 13

11. Equal Employment Opportunity.....GC 14

12. Subcontracting.....GC 16

13. Monthly Progress Estimates and Payments.....GC 17

14. Deposit of Securities.....GC 18

15. Payment Retention.....GC 18

16. Payment for Extra Work (Force Account Basis).....GC 18

17. Change Orders – Detail Drawings and Instructions.....GC 19

18. Final Payment.....GC 19

19. Assignment of Claims.....GC 20

20. Arbitrations.....GC 20

21. Claims Resolution.....GC 20

22. Brand or Trade Name – Substitute of Equals.....GC 23

23. Site Inspection – Effect of Other Improvements Shown and Contractor Procedure..GC 24

24. Public Safety.....GC 25

25. Extra Work.....GC 27

26. Noise Control.....GC 27

27. Use, Care and Protection of Premises.....GC 28

28. Obstructions.....GC 29

29. Removal of Asbestos and Hazardous Substances.....GC 29

30. Documents of ContractorGC 30

31. In-Use Off-Road Diesel-Fueled Fleet Certificate Of Reported Compliance.....GC 30

32. Responsibility of Contractor to Act in an EmergencyGC 30

33. Final Inspection – Notice of Completion.....GC 30

34. Dust AbatementGC 31

General Conditions

1. Definitions and Terms

Whenever in the Standard Specifications the following terms are used, they shall be understood to mean and refer to the following:

- A. “Department”, “Department of Transportation”, “State”, and “State of California” means the County of Riverside.
- B. “Engineer”, and “Director” means the Director of Transportation and Land Management Agency (TLMA) for the County of Riverside, and includes his authorized representatives.
- C. “Laboratory” means the established laboratory of the County of Riverside.
- D. “Plans” means the portion of the Contract Documents consisting of all drawings prepared for the direction and characteristics of the work. A schedule of said drawings which constitutes the plans as of the execution of the Contract is set forth in the Special Provisions and are supplemented by the Standard Plans referred to in the Special Provisions.

Other terms appearing in the Specifications and Contract Documents, including the Special Provisions, shall have the intent and meaning specified in Section 1-1.07, "Definitions" of the Standard Specifications. The following are additional terms appearing in the Contract Documents:

- “County”, “Contractor” and “Contract Documents” are identified in the Contract. “County” and “Contractor” includes their authorized representatives are treated throughout as if each were singular in number. “Contractor” includes its surety.
- “Contract Documents” are identified in the Contract.
- “Business Day” is defined as 7:30 a.m. to 5:30 p.m. Monday through Friday, excepting therefrom when County is closed for holidays as set forth in County Ordinance 358, Section 1, items c. through q.
- “You” and “Your” means the Bidder and/or Contractor.
- “Specifications and Contract Documents” means the County’s Bid Book comprised of the forms, drawings, table of contents, specifications and contract documents for the construction of the County’s transportation, Emergency Repair Work or road project.

2. Standard Specifications

The Standard Specifications of the State of California Department of Transportation, edition of **2018** hereafter called "Standard Specifications", including amendments and revisions to the Standard Specifications, are incorporated herein as modified in these General Conditions, the Instructions to Contractors, the Special Provisions and the Plans.

General Conditions govern over all the Contract Documents except the Special Provisions, the Contract, and Bonds.

The following subsections of the Standard Specifications are deleted:

- 2-1.15C(2), DVBE Incentive
- 3-1.08, Small Business Participation Report
- 3-1.11, Payee Data Record
- 8-1.04B, Standard Start
- 12-1.04, Payment (for Flagging Costs)

The Standard Specifications of the State of California Department of Transportation, edition as listed in Special Provision Specifications and Plans General Section 1-1.01, hereafter called "Standard Specifications", are incorporated herein as modified in these Special Provisions and the Plans.

Amendments to the Standard Specifications for this project, **as dated in the Special Provisions**, are incorporated herein. During the advertisement period of this project, this document is available upon request at the office of the County of Riverside Transportation Department and will be available to the awarded Contractor.

Amendments to the Standard Specifications set forth in the Special Provisions shall be considered as part of the Standard Specifications. Whenever either the term "Standard Specifications is amended" or the term "Standard Specifications are amended" is used in the Special Provisions, the text or table following the term shall be considered an amendment to the Standard Specifications.

In case of conflict between such amendments and the Standard Specifications, the amendments shall take precedence over and be used in lieu of the conflicting portions.

In case of conflict between the Standard Specifications and these Special Provisions, the Special Provisions shall take precedence over and be used in lieu of such conflicting portions.

In the event that discrepancies are encountered which are not addressed herein, the option that provides the method, item or material with the greatest strength, utility, performance shall be selected, as directed by the Engineer.

3. Director of Transportation and Land Management Agency (TLMA)

All work shall be done under the supervision of the Director of TLMA who shall determine the amount, quality, acceptability and fitness of all parts of the work, and interpret the Contract Documents. No act or omission of the Director of TLMA relieves Contractor of the duty to proceed with the work in strict conformity with the Contract Documents.

Upon request, Director of TLMA shall reduce to writing any oral order, objection, requirement or determination. Whenever the Director of TLMA's approval is required, it shall be in writing only.

All communications to the County by Contractor shall be via the Director of TLMA, or such individual(s) as may be designated by the Director of TLMA in his discretion.

No work shall be performed on site other than during normal working hours without the knowledge and consent of the Director of TLMA.

When in Director of TLMA's opinion, weather or other conditions are such that attempts to perform a portion of the work will probably result in work not in accordance with the Contract Documents, he shall so advise the Contractor. When Contractor advises the Director of TLMA that he intends to proceed despite such advice, he does so at his peril. The Director of TLMA may then order Contractor, in writing which specifies the portion of the work involved and the conditions warranting the issuance of the order, not to proceed on such portion of the work if: (1) proceeding will, in his judgment, have an adverse effect on Contractor's ability to complete the work within the stipulated time period, or (2) proceeding will, in his judgment, necessitate unusual tests and procedures to ascertain whether said portion of the work is in accordance with the Contract Documents. Contractor shall comply with such orders at its expense.

Nothing herein contained relieves Contractor from the duty to make independent determinations as to weather and other conditions affecting the proper completion of the work.

Failure for any reason of Director of TLMA to advise Contractor as to such matters, or to issue an order as above provided, does not relieve the Contractor from the duty to accomplish the work in accordance with the Contract Documents.

As stated elsewhere, amounts shown in the Contract as to quantities are merely estimates only. From time to time Director of TLMA shall direct Contractor as to the prosecution of the work in such a manner as to increase or decrease such estimates as to the work actually to be done. Contractor shall comply with such instructions and shall be paid only for work actually done based on the unit price set out in the Contract.

4. Insurance and Hold Harmless

Within five (5) working days of the Notice to Proceed and prior to commencement of work, the successful Contractor must submit a certificate of insurance, including required endorsements, which provides evidence that the bidding Contractor has insurance coverage that meets the requirements of this section.

In lieu of the provisions of Standard Specification Section 3-1.07, "Insurance Policies" and Section 7-1.06, "Insurance", the following shall apply:

A. General:

Contractor shall submit to the County a Certificate of Insurance, signed by an authorized representative of the Contractor's insurance provider or agency, which certifies to the County that insurance coverage is provided in accordance with the requirements of this Section.

Certificate Holder information is as follows:

County of Riverside
Transportation Department
Attn: Contracts/Bidding Unit
3525 14th Street
Riverside, CA 92501

Contractor shall not commence work under the Contract until he has obtained the insurance required hereunder and satisfactory proof of said insurance has been submitted to and accepted by the County.

The County may suspend all Contractor project work activities, at the Contractor's expense, for failure to maintain insurance coverage.

B. Workers Compensation:

The Contractor shall maintain statutory Workers' Compensation Insurance (Part 1) as prescribed by the laws of the State of California. Policy shall include Employers' Liability (Part 2) including Occupational Disease with limits not less than \$1,000,000 per person per accident.

This policy shall be endorsed, and signed, to waive subrogation in favor of the County.

C. Commercial General Liability:

Commercial General Liability insurance coverage includes but not limited to:

1. Premises, operations and mobile equipment liability
2. Products and completed operations liability
3. Broad form property damage, (including completed operations)
4. Explosion, collapse, and underground hazards
5. Personal and advertising injury
6. Unmodified contractual liability
7. Cross liability coverage
8. Covering claims which may arise from or out of Contractor's performance of its obligations hereunder.

Commercial General Liability insurance coverage amounts are not to be less than the following:

- \$2,000,000 each occurrence
- \$4,000,000 general aggregate
- \$2,000,000 products-completed operations aggregate

Higher limits may be required for projects with higher risk exposure, and higher limits, if required, will be included in the Special Provisions.

Where excess liability insurance is used in connection with primary liability insurance, the combination of such coverage sum must allow total limits of liability to be in amounts not less than the specified amounts.

This policy shall name the "County of Riverside, its Agencies, Special Districts and Departments, their respective director, officers, Board of Supervisors, elected and appointed officials, employees, agents, and representatives" as Additional Insureds.

For additional insured endorsement for excess liability insurance, an acceptable alternative to the policies is a letter, signed by an authorized representative of the insurance carrier, confirming in writing that the policy follows form with respect to the primary liability policy.

D. Automobile Liability:

Contractor shall maintain liability insurance for any auto, all owned, non-owned and hired vehicles so used in an amount not less than \$1,000,000 per occurrence combined single limit. If such insurance contains a general aggregate limit, it shall apply separately to the Contract or be no less than two (2) times the occurrence limit.

Policy shall name the “County of Riverside, its Agencies, Special Districts and Departments, their respective director, officers, Board of Supervisors, elected and appointed officials, employees, agents, and representatives” as Additional Insureds.

E. General Insurance Provisions:

1. **Insurer.** Any insurance carrier providing insurance coverage hereunder shall be admitted to the State of California and have an A M Best rating of not less than A: VIII (A:8) unless such requirements are waived, in writing, by the County Risk Manager. If the County’s Risk Manager waives a requirement for a particular insurer such waiver is only valid for that specific insurer and only for one policy term.

Non-admitted/Surplus Line insurance carriers (carriers not licensed in the State of California) may be acceptable to the County under certain conditions. Non-admitted insurance carriers providing any form of insurance coverage must be:

- a. Domiciled or authorized to do business in the United States and/or listed as an approved insurance carrier on the California Department of Insurance’s List of Approved Surplus Line Insurers (LASLI) list,
 - b. Have an AM Best rating of not less than A: VIII (A:8), and
 - c. Insurer is authorized to transact in the type of insurance provided.
2. **Self-insured retention (SIR).** The Contractor must declare its insurance self-insured retention for each coverage required herein. If any such self-insured retention exceeds \$500,000 per occurrence, each such retention shall have the prior written consent of the County Risk Manager before the commencement of operations under the Contract. Upon notification of self-insured retention unacceptable to the County, and at the election of the Country’s Risk Manager, Contractor’s carriers shall either:
 - a. Reduce or eliminate such self-insured retention as respects the Contract with the County, or
 - b. Procure a bond which guarantees payment of losses and related investigations, claims administration, and defense costs and expenses.
 3. **Certificate, policy, endorsements and attachments.** Contractor shall cause Contractor’s insurance carrier(s) to furnish the County with:
 - a. A properly executed original Certificate(s) of Insurance and certified original copies of signed endorsements effecting coverage as required herein, and
 - b. All endorsements must include a reference to the policy by type of insurance and policy number that it is endorsing, and

- c. If requested to do so by the County Risk Manager, provide original certified copies of policies including all endorsements and all attachments thereto, showing such insurance is in full force and effect.

Further, said Certificate(s) and policies of insurance shall contain the covenant of the insurance carrier(s) that thirty (30) days written notice shall be given to the County prior to any material modification, cancellation, expiration or reduction in coverage of such insurance (For nonpayment of premium cause for cancellation, a written notice of at least ten (10) days is allowed per California Insurance Code §662(a)). In the event of a material modification, cancellation, expiration, or reduction in coverage, the Contract shall terminate forthwith, unless the County receives, prior to such effective date, another properly executed original Certificate of Insurance and original copies of endorsements or certified original policies, including all endorsements and attachments thereto evidencing coverage's set forth herein and the insurance required herein is in full force and effect.

Contractor shall not commence operations until the County has been furnished original Certificate (s) of Insurance and certified original copies of endorsements and if requested, certified original policies of insurance including all endorsements and any and all other attachments as required in this Section. An individual authorized by the insurance carrier to do so on its behalf shall sign the original endorsements for each policy and the Certificate of Insurance.

4. **Primary insurance.** It is understood and agreed to by the parties hereto that the Contractor's insurance shall be construed as primary insurance, and the County's insurance and/or deductibles and/or self-insured retention's or self-insured programs shall not be construed as contributory.
5. **Subcontractor(s).** Contractor shall pass down the insurance obligations contained herein to all tiers of subcontractors working under the Contract.
6. **Self-insurance.** The insurance requirements contained in the Contract may be met with a program(s) of self-insurance acceptable to the County.
7. **Claim notification.** Contractor agrees to notify County of any claim by a third party or any incident or event that may give rise to a claim arising from the performance of the Contract.
8. **Certificate Holder.** Certificate address information for this project is as follows:

County of Riverside
Transportation Department
Attn: Contracts/Bidding Unit
3525 14th Street
Riverside, CA 92501

F. Hold Harmless/Indemnification:

Contractor shall indemnify and hold harmless the County of Riverside, its Agencies, Districts, Special Districts and Departments, their respective directors, officers, Board of Supervisors, elected and appointed officials, employees, agents and representatives (individually and collectively hereinafter referred to as Indemnitees) from any liability whatsoever, based or asserted upon any services of Contractor, its officers, employees, subcontractors, agents or representatives arising out of or in any way relating to the Contract, including but not limited to property damage, bodily injury, or death or any other element of any kind or nature whatsoever arising from the performance of Contractor, its officers, employees, subcontractors, agents or representatives Indemnitors from the Contract. Contractor shall defend, at its sole expense, all costs and fees including, but not limited, to attorney fees, cost of investigation, defense and settlements or awards, the Indemnitees in any claim or action based upon such alleged acts or omissions.

With respect to any action or claim subject to indemnification herein by Contractor, Contractor shall, at their sole cost, have the right to use counsel of their own choice and shall have the right to adjust, settle, or compromise any such action or claim without the prior consent of County; provided, however, that any such adjustment, settlement or compromise in no manner whatsoever limits or circumscribes Contractor's indemnification to Indemnitees as set forth herein.

Contractor's obligation hereunder shall be satisfied when Contractor has provided to County the appropriate form of dismissal relieving County from any liability for the action or claim involved.

The specified insurance limits required in the Contract shall in no way limit or circumscribe Contractor's obligations to indemnify and hold harmless the Indemnitees herein from third party claims.

In the event there is conflict between this clause and California Civil Code §2782, this clause shall be interpreted to comply with Civil Code 2782. Such interpretation shall not relieve the Contractor from indemnifying the Indemnitees to the fullest extent allowed by law.

5. Beginning of Work, Time of Completion, and Liquidated Damages

Attention is directed to Instruction to Contractors Section 6, "Hours of Work."

Attention is directed to the Special Provision Section "Prosecution and Progress".

Attention is directed to the Special Provision Section "Time of Completion".

Attention is directed to the Special Provision Section "Liquidated Damages".

6. County's Right to Stop Work or Terminate the Contract

(1) Contractor shall be adjudged bankrupt or make an assignment for the benefit of creditors, or (2) a receiver or liquidator is appointed for Contractor or any of his property, or (3) Contractor shall refuse or fail after Notice of Warning from County by Director of TLMA to supply sufficient properly skilled workmen or suitable materials, or (4) Contractor fails to prosecute the work with such diligence as will insure its completion within the stipulated time period, or (5) Contractor shall fail to make payments to persons supplying labor or materials for the work, or (6) Contractor does not comply with applicable law or instructions of Director of TLMA, or (7) Contractor is otherwise guilty of a substantial violation of any provision of the Contract Documents, then County without prejudice to such other and further right, remedy or relief it may be entitled to, may by ten (10) days notice to Contractor, terminate the employment of Contractor and his right to proceed, either as to the entire work, or at County's option, as to any portion thereof as to which delay shall have occurred or breach or miscompliance relates, and may thereupon take possession of the affected work and complete the work by contract or otherwise, as County deems expedient. In such case, Contractor shall not be entitled to receive any further payment until the work is finished. If the unpaid balance shall exceed the expense of completion, and other damage, expense or loss of County occasioned by Contractor's failure to properly perform, such excess shall be paid by Contractor. If such expense and damage exceeds the unpaid balance, Contractor is liable to County for the excess. If County elects to proceed under this Section, it may take possession of and utilize in completing the work such materials, supplies, plant and equipment on site which may be necessary or convenient for the purpose of completing the work, County is expressly granted the right - acting via Director of TLMA, an Engineer or otherwise - to operate equipment and machinery on site for the purpose of determining whether it has a basis for proceeding under this Section.

If the construction of the project herein is damaged, which damage is determined to have been proximately caused by an act of God, in excess of 5% of the contract amount (Public Contract Code §7105(a)), provided that the work damaged is built in accordance with applicable building standards and the plans and specifications, then the Owner, upon certification by the Engineer, may, without prejudice to any other right of remedy, terminate the contract.

Decision by County not to proceed under this Section does not constitute a waiver by County of any right it might from time to time have against Contractor under the Contract Documents.

7. General Prevailing Wage:

Attention is directed to General Conditions Section 8, "Labor Code".

Attention is also directed to Section 7-1.02K(2), "Wages" of the Standard Specifications.

Pursuant to §1773 of the Labor Code, the general prevailing wage rates, including the per diem wages applicable to the work, and for holiday and overtime work, including employer

payments for health and welfare, pension, vacation, and similar purposes, in the county in which the work is to be done have been determined by the Director of the California Department of Industrial Relations (DIR). These wages are set forth in the General Prevailing Wage Rates for this project and are available from the DIR's web site at: <http://www.dir.ca.gov>

Pursuant to §1774 of the Labor Code, contractor and subcontractors shall pay not less than the specified prevailing rates of wages to all workmen employed in the Contract.

General prevailing wage determinations are on file at Transportation Department Washington Street Yard's Contraction/Inspection office and are available to any interested party upon written request.

General prevailing wage determinations are also made by the DIR Pursuant to California Labor Code Part 7, Chapter 1, Article 2, Sections 1770, 1773, and 1773.1 may also be obtained at the following URL:

www.dir.ca.gov/DLSR/PWD/index.htm

The Contractor must post a copy of the determination of the DIR prevailing rate of per diem wages at each job site.

8. Labor Code

Reference is made to Chapter 1, Part 7, Division 2 of the California Labor Code (commencing with §1720). By this reference said Chapter 1 is incorporated herein with like effect as if it were here set forth in full. The parties recognize that said Chapter 1 deals, among other requirements with discrimination, penalties and forfeitures, their disposition and enforcement, wages, working hours, overtime, apprentices, securing worker's compensation insurance, payroll records, registration with the DIR, and directly affect the method of prosecution of the work by Contractor and subject it under certain conditions to penalties and forfeitures. Execution of the Contract by the parties constitutes their agreement to abide by said Chapter 1, their stipulation as to all matters which they are required to stipulate as to by the provisions of said Chapter 1, constitutes Contractor's certification that he is aware of the provisions of said Chapter 1 and will comply with them and further constitutes Contractor's certification as follows: "I am aware of the provisions of §3700 of the California Labor Code which require every employer to be insured against liability for worker's compensation or to undertake self-insurance in accordance with the provisions of that Code, and I will comply with such provisions before commencing the performance of the work of this contract."

Contractor and his subcontractors shall comply with the provisions of §1725.5 of the Labor Code regarding registration with the DIR. Registration with the DIR Division of Labor Standards Enforcement can be done online using the following URL:

<https://efiling.dir.ca.gov/PWCR/>

Contractor and his subcontractors shall comply with the provisions of §1776 of the Labor Code regarding payroll records.

Contractor and his subcontractors shall comply with the provisions of §1777.5 of the Labor Code regarding apprentices.

Contractor shall post at each job site, during the course of the work, notices and a copy of County's "Determination of Prevailing Wage Rates". Copies of said Determination are available at Transportation Department Washington Street Yard's Contraction/Inspection office for this purpose.

9. Labor Nondiscrimination

Contractor's attention is called to the "Nondiscrimination Clause", set forth in Section 7-1.02I(2), "Nondiscrimination", of the Standard Specifications, which is applicable to all nonexempt state contracts and subcontracts, and to the "Standard California Nondiscrimination Construction Contract Specifications" set forth therein. The Specifications are applicable to all nonexempt state construction contracts and subcontracts of \$5,000 or more.

10. Title VI Nondiscrimination

Contractor shall comply with Title VI of the Civil Rights Act of 1964, 78 Stat. 252, 42 U.S.C. 2000d-42 U.S.C. 2000d-4 (ACT), and all requirements imposed by or pursuant to 49 CFR, Subtitle A, Part 21, "Nondiscrimination in Federally-Assisted Programs of the Department of Transportation - Effectuation of Title VI of the Civil Rights Act of 1964" (REGULATIONS), the Federal-aid Highway Act of 1973, and other pertinent directives, to the end that in accordance with the ACT, REGULATIONS, and other pertinent directives, no person in the United States shall, on the grounds of race, color, sex, national origin, religion, age or disability, be excluded from participation in, be denied the benefits of, or be otherwise subjected to discrimination under this construction contract.

Construction contract includes the administration, award and performance of any State and/or Federal funded contract or the requirements of 49 CFR Part 26.

Contractor must refer to Caltrans Local Assistance Procedures Manual, Exhibit 4-C, Master Agreement, Administering Agency-State Agreement for Federal-Aid Projects to obtain current Nondiscrimination Assurances requirements to include in all subcontracts signed by the Contractor. This Exhibit 4-C can be obtained from the following website:

<http://www.dot.ca.gov/hq/LocalPrograms/lam/forms/lapmforms.htm>
(Refer to Exhibit 4-C, Appendix A to Exhibit B, Nondiscrimination Assurances)

Title VI Assurances requirements, as incorporated in Caltrans Exhibit 12-G (January 2019 update).

Attention is also directed to these General Conditions' Section 30, "Documents of Contractor." Contractor shall permit access to its books, records, accounts, other sources of information and its facilities as may be determined by the County, State or Federal Highway Administration to be pertinent to ascertain compliance with 49 CFR, Subtitle A, Part 21.

In the event of noncompliance with the nondiscrimination provisions, the County shall impose sanctions, as maybe determined deemed appropriate and/or as directed by Federal funding source determination, including but not limited to: withholding of payments within a reasonable period of time, not to exceed 90 days; and/or cancellation, termination or suspension of the Contract, in whole or in part.

For Title VI nondiscrimination complaints related to this project please contact:

Frances Segovia
Title VI Coordinator

County of Riverside
Transportation Department
3525 14th Street
Riverside, CA 92501

Facsimile: (951) 955-3164
Office: (951) 955-1646
Electronic mail: fsegovia@rctlma.org

11. Equal Employment Opportunity

A. General

Contractor shall not discriminate in its recruiting, hiring, promotion, demotion or termination practices on the basis of race, religious creed, color, national origin, ancestry, sex, age or physical handicap in the performance of this Contract shall comply with the provisions of the California Fair Employment Practice Act (commencing with SS 1410 of the Labor Code), the Federal Civil Rights Act of 1964 (P.L. 88-352) and all amendments thereto, Executive Order No. 11246 (30 Federal Register 12319), as amended, and all administrative rules and regulations issued pursuant to said Acts and Order. See particularly 41 Code of Federal Regulation (CFR) Chapter 60.

Contractor shall require each of its subcontractors to comply with the preceding paragraph and shall include in each subcontract language similar to the preceding paragraph.

Contractor shall permit access to its records of employment, employment advertisement, application forms and other pertinent data and records by Owner and any State or Federal

agency having jurisdiction for the purpose of investigation to ascertain compliance with this Section.

Owner may assign an affirmative action representative to monitor Contractor and its subcontractor(s) conduct required by this Section, including the right of entry to the construction site for the purpose of obtaining information from persons performing work on the project providing such inspection does not interfere with the progress of the work.

Elsewhere in the Contract Documents specific requirements may be contained covering the same subject matter of this Section. If so, such specific requirements prevail over this Section in case of conflict.

B. Transactions of \$10,000 or Under

Contracts and subcontracts not exceeding \$10,000 are exempt from the requirements of this Section. No Contractor or subcontractor shall procure supplies and/or services in less than usual quantities to avoid applicability of this Section. With respect to contracts and subcontracts for indefinite quantities, this Section applies unless the amount required in any one year under such contract will reasonably be expected not to exceed \$10,000.

C. Transactions in Excess of \$10,000, but Less Than \$50,000

At Owner's request, Contractor shall certify that it has in effect an affirmative action plan and agrees to comply with all State and Federal laws and regulations regarding Fair Employment Practices. Contractor shall maintain a written copy of its affirmative action plan and furnish Owner a copy of the plan upon request. Owner may require Contractor to complete an Affirmative Action Compliance Report, on a form furnished by Owner, setting forth definite goals during the term of the Contract.

D. Transactions of \$50,000 or More

If Contractor has fifty or more employees and a Contract for \$50,000 or more, it shall develop and submit to Owner, within thirty days after award, a written affirmative action compliance program providing in detail specific steps to guarantee equal employment opportunity. Contractor shall include in its affirmative action program a table of job classifications, which table shall include but need not be limited to job titles, duties, and rates of pay.

Contractor shall in each subcontract let to do a portion of the work covered hereunder, where the subcontractor involved has fifty or more employees and the subcontract is for \$50,000 or more, impose in the subcontract the above requirements.

For the purpose of determining the number of employees, the average of the Contractor's or its subcontractor's employees for the twelve month period immediately prior to award, or the total number of employees the Contractor or its subcontractor will have when performing this contract, whichever is higher, shall be used.

E. Federal Assisted Construction

If this project is a Federally assisted construction project, then the contract provisions contained in 41 CFR SS 60-1.04 (b) are incorporated herein and the Contractor shall likewise incorporate said provisions in each subcontract entered by Contractor to perform the work. Federally assisted construction is identified as such in the Specifications and Contract Documents .

12. Subcontracting

Attention is directed to:

- Standard Specification Section 5-1.13, "Subcontracting", and
- Instructions to Contractors Section 3, "Contract Participation".
- Instructions to Contractors Section 4, "Subletting, Subcontracting, and Subcontractor List".

Contractor responsibility

No subcontract releases the Contractor from the contract or relieves the Contractor of their responsibility for a subcontractor's work.

Violations and remedies

If the Contractor violates Public Contract Code § 4100 et seq., the County may exercise the remedies provided under Public Contract Code § 4110. The County may refer the violation to the Contractors State License Board as provided under Public Contract Code § 4111.

50% Minimum work performance

The Contractor shall perform work equaling at least 50 percent of the value of the original total agreed estimate for emergency repair work Contract with the Contractor's own employees and equipment, owned or rented, with or without operators. The Standard Specification Subcontracting Section 5-1.13A, "General" fifth paragraph is deleted.

Subcontractor compliance

Each subcontractor must comply with the contract.

Active license

Each subcontractor must have an active and valid State contractor's license with a classification appropriate for the work to be performed (Business & Professional Code, § 7000 et seq.).

Submittal of subcontracts

Contractor must submit copies of subcontracts upon request by the Engineer.

Submittal of subcontractor request form

Before subcontracted work starts, Contractor must submit a Subcontracting Request form (Caltrans LAPM, Exhibit 16-B).

Debarred contractors

The County will not award a contract to a debarred Contractor. Contractor must not use a debarred subcontractor. Pursuant to the provisions in §1777.1 of the Labor Code, the Labor Commissioner publishes and distributes a current list of contractors ineligible to perform work on a public works project. This list of debarred contractors is available from the DIR web address at:

<http://www.dir.ca.gov/dlse/debar.html>

Termination of unsatisfactory subcontractors

Upon request by the Engineer, Contractor must immediately remove and not again use a subcontractor who fails to prosecute the work satisfactorily (Public Contract Code §4107(a)(7)).

Substitutions

Subcontractor substitutions will be processed as required by Public Contract Code § 4107 et seq. A subcontractor not registered with the DIR is an additional condition to the listed qualifications for substitutions (Public Contract Code 1771.1(d)).

13. Monthly Progress Estimates and Payments

Attention is directed to Section 9-1.16, "Progress Payments" and 9-1.17, "Payment After Contract Acceptance" of the Standard Specifications and these Special Provisions.

For the purpose of timely payment, the "receipt of payment request" date, as described in Public Contract Code 20104.50 and as referred to herein, shall be considered to be the fifth working day following the 25th day of each month.

Within five (5) working days of the 25th day of each month the County shall:

- A. Calculate and prepare the certificate ("progress pay estimate") stating the value of the work completed for the billing month, for the purpose of determining the proper progress payment amount.
- B. If a progress pay estimate has been prepared by the County but has been contested by the Contractor as of the "receipt of payment request" date, as defined above, the County shall submit to the Contractor a document setting forth in writing a description of the dispute pertaining to the progress billing, and the County's reason for its position. Said document shall be submitted to the Contractor as soon as practicable, but not later than seven (7) calendar days after the "receipt of payment request" date.

Any progress pay estimate which is undisputed and remains unpaid for thirty (30) calendar days, after the "receipt of payment request date" shall accrue interest to the Contractor equivalent to the legal rate set forth in subdivision (a) of §685.010 of the California Code of Civil Procedure. The number of days available to the County to make a payment without incurring interest pursuant to this Section shall be reduced by the number of days by which the County exceeds the seven-day submittal requirement set forth in the paragraph above.

Pursuant to Public Contract Code §20104.50, subsection (e), the progress payment date is the date that funds are encumbered and the payment warrant is issued.

The partial payments made as the work progresses will be payment on account on work performed as of the 25th of the month and shall in no way be considered as an acceptance of any part of the work or material of the contract, nor shall they in any way govern the final estimate.

No estimate or payment shall be made when, in the judgment of the Director of TLMA, the total value of the work done since the previous estimate amounts to less than \$300.

14. Deposit of Securities

In accordance with Public Contract Code §22300 and other applicable law, the Contractor may substitute securities for any moneys withheld to ensure performance under the contract.

15. Payment Retention

Director of TLMA, once each month, after said work is commenced and until after the completion and acceptance thereof, shall make and deliver to Contractor duplicate certificates stating the value of work then completed according to the contract, estimated according to the standard of the unit contract price, and thereupon Contractor shall be paid an amount sufficient with all previous payments to make the aggregate ninety five percent (95%) of the amount earned as certified. Maximum value of progress payment retention, as set forth by Public Contract Code §7201 and any other referenced text, shall be five (5%).

16. Payment for Extra Work (Force Account Basis)

Extra work to be paid for on a force account basis as directed by the Engineer will be paid for as set forth in Section 9-1.04 "Force Account" of the Standard Specifications. The labor surcharge, equipment rental rates, and the right of way delay factors for each classification of equipment are listed in the Department of Transportation publication entitled "Labor Surcharge and Equipment Rental Rates". A copy of which is on file at the Office of the Director of TLMA and is hereby incorporated herein in its entirety.

17. Change Orders – Detail Drawings and Instructions

Reference is made to Section 4-1.05, “Changes and Extra Work” of the Standard Specifications regarding change orders.

Each approved change order shall be considered as an amendment to the Contract Documents and will not be considered approved until executed by the Board of Supervisors, except when Director of TLMA can approve certain change orders, without the necessity of approval by the Board, as provided in a Resolution of the Board adopted January 29, 2019, Resolution 2019-035.

The above does not limit the ability of Director of TLMA to issue further detail drawings, explanations, and instructions which are customarily given by an Engineer during the course of similar work. Director of TLMA will furnish Contractor, in reasonable promptness, with further detailed explanations, instructions and drawings as may be necessary for the proper execution of the work, and Contractor shall conform to same provided they are consistent with the intent of the Contract Documents. In giving such additional instructions, explanations and drawings Director of TLMA has authority to make minor changes in the work which do not involve extra cost and are not inconsistent with the Contract Documents.

Contractor's acting on such instructions, explanations and drawings of Director of TLMA means that Contractor agrees that such explanations, instructions and drawings are within the scope of the work in accordance with the intent of the Contract Documents and do not constitute a basis for modification of the Contract Documents as to price or time.

18. Final Payment

Within thirty (30) days after the completion of the work and its acceptance by the Board of Supervisors, Director of TLMA will make a proposed final estimate in writing of the quantities of work done under the contract and the value of such work and will submit such estimate to Contractor. Within thirty (30) days thereafter Contractor shall submit to Director of TLMA his written approval of said proposed final estimate or a written statement of all claims which he has for additional compensation claimed to be due under the contract.

On Contractor's approval or if he files no claims within said period of thirty (30) days, Director of TLMA will issue a final written estimate as submitted to Contractor and County shall pay the entire sum so found to be due after deducting there from all previous payments and all amounts to be kept and all amounts to be retained under the provisions of the contract.

If Contractor files claim(s) within said period of thirty (30) days, Director of TLMA will issue as a semi-final estimate the proposed estimate submitted to Contractor and the County will within thirty (30) days pay the sum found due thereon after deducting all prior payments and all amounts to be kept and retained under the provisions of the contract, Director of TLMA shall then consider and investigate Contractor's claims and shall make such revisions in the

said estimate as he may find to be due, and shall then make and issue his final written estimate. County will pay the amount so found due after deducting all previous payments and amount to be retained under the contract.

All prior or partial estimates and payments shall be subjected to correction in the final estimate and payment.

The final estimate shall be conclusive and binding against both parties to the contract on all questions relating to the performance of the contract and the amount of work done there under and compensation therefore, except in the case of gross error. Acceptance of final payment constitutes a release of County by Contractor of all claims relating to the work except those filed pursuant to section 21 herein prior to final payment.

19. Assignment of Claims

In signing the Contract on this public works project, or any subcontractor agreeing to supply goods, services, or materials, and entering a contract pursuant thereto, the Contractor and/or subcontractor do offer and agree to assign to the Owner all rights, title, and interest in and to all causes of action it may have under Section 4 of the Clayton Act (15 U.S.C. Section 15) or under the Cartwright Act (Chapter 2 (commencing with §16700) of Part 2 of Division 7 of the Business and Professions Code), arising from purchases of goods, services, or materials pursuant to the public works contract or the subcontract. This assignment shall be made and become effective at the time the awarding body tenders final payment to the Contractor, without further acknowledgement by the parties.

20. Arbitrations

Section 9-1.22, "Arbitration" of the Standard Specifications is deleted.

21. Claims Resolution

21.1 Definition of a Claim

A Claim means a separate demand by a Contractor for one or more of the following:

- a. A time extension, including, without limitation, for relief from damages or penalties for delay assessed by the County under the contract.
- b. Payment by the County of money or damages arising from work done by, or on behalf of, the Contractor pursuant to the contract and payment for which is not otherwise expressly provided or to which the Contractor is not otherwise entitled.
- c. Payment of an amount that is disputed by the County.

21.2 Form and Contents of Claim(s)

The Contractor shall furnish reasonable documentation to support the Claim, which shall be sent by registered mail or certified mail with return receipt requested to the County at the address provided herein this Section 21. The Contractor's written Claim must include, but not limited to, the following:

- (1) a statement to identify that it is a Claim under this Section 21, on a company letterhead, and a request for a decision on the Claim;
- (2) A detailed description or narrative of pertinent events, act, error, omission, unforeseen condition, event or other circumstance giving rise to the Claim;
- (3) Citation to contract provisions;
- (4) Theory of entitlement that provides a detailed justification for any remedy or relief sought by the Claim. This includes, but not limited to: a detailed cost breakdown, invoices, material tickets, staff logged time, summary of quantities, other cost records and total cost calculations;
- (5) Complete pricing of all cost impacts;
- (6) A time impact analysis of all time delays that shows actual time impact on the critical path; and
- (7) Documentation, County letters, notifications, related drawings and photos supporting items (1) through (6).

The Claim must be verified under penalty of perjury by Contractor's project superintendent as to the Claim's accuracy, and shall be priced like a Change Order, and must be updated at regular intervals as to cost and entitlement if a continuing Claim. Routine contract materials, for example, correspondence, RFI, Change Order requests, or payment requests shall not constitute a Claim. Contractor shall bear all costs incurred in the preparation and submission of a Claim.

Claims and support documentation related must be sent to:

County of Riverside, TLMA
Transportation Department
Construction Inspection Office
2850 Washington Street
Riverside, CA 92504

Attention: Cindi Wachi, Construction Engineering Division Manager

21.3 Claims Procedure

21.3.1 Upon receipt of a Claim and the supporting documentation, the County shall conduct a reasonable review of the Claim and within forty-five (45) days, or an extended period as may be set by mutual agreement of the County and Contractor, provide the Contractor with a written statement identifying what portion of the Claim is still disputed and what portion is undisputed.

21.3.2 Notwithstanding the time period set forth in 21.3.1 above, if the County needs approval from the Board of Supervisors to provide the Contractor with a written statement identifying the disputed portion and the undisputed portion of the Claim, and the Board of Supervisors does not meet within the forty-five (45) days or within the mutually agreed to extension of time following receipt of the Claim, the County shall have up to three (3) days following the next duly publicly noticed meeting of the Board of Supervisors after the forty-five (45) day period, or extension, expires to provide Contractor a written statement identifying the disputed portion and the undisputed portion of the Claim.

21.3.3 Any payment due on the undisputed portion of the Claim under this section shall be processed and made within sixty (60) days after the County issues its written statement. Amounts not paid in a timely manner as required by this Section 21 shall bear interest at 7 percent per annum. If the County fails to issue a written statement, the Claim shall be deemed rejected in its entirety. Failure by the County to respond to a claim from a contractor within the time periods described in this subdivision or to otherwise meet the time requirements of this section shall result in the claim being deemed rejected in its entirety. A Claim that is denied by reason of the County's failure to have responded to the Claim, or its failure to otherwise meet the time requirements of this section, shall not constitute an adverse finding with regard to the merits of the Claim or the responsibility or qualifications of the Contractor.

21.3.4 If the Contractor disputes the County's written response, or if the County fails to respond within the time prescribed, the Contractor may demand in writing, sent by registered mail or certified mail return receipt requested, an informal meet and confer conference for settlement of the portion of the Claim in dispute. Upon receipt of the demand, the County shall schedule a meet and confer conference within thirty (30) days.

21.3.5 Within ten (10) business days following the conclusion of the meet and confer conference, if the Claim or any portion thereof remains in dispute, the County shall provide the Contractor a written statement identifying the portion of the Claim that remains in dispute and the portion that is undisputed. Any payment due on an undisputed portion shall be processed and made within sixty (60) days after the County issues its written statement.

Any disputed portion of the Claim, as identified by the Contractor in writing, shall be submitted to nonbinding mediation, with the County and Contractor sharing the associated costs equally. The County and Contractor shall mutually agree to a mediator within ten (10) business days after the disputed portion of the Claim has been identified in writing. If the parties cannot agree upon a mediator, each party shall select a mediator and those mediators shall select a qualified neutral third party to mediate with regard to the disputed portion of the Claim. Each party shall bear the fees and costs charged by its respective mediator in connection with the selection of the neutral mediator.

21.3.6 For purposes of this section, mediation includes any nonbinding process, including but not limited to, neutral evaluation or a dispute review board, in which an independent third party or board assists the parties in dispute with resolution through negotiation or by issuance of an evaluation. Any mediation utilized shall conform to the timeframes in this section.

Unless otherwise agreed to by the County and the Contractor in writing, the mediation conducted pursuant to this Section 21 shall excuse any further obligation under Section 20104.4 of the Public Contract Code to mediate after litigation has been commenced.

21.3.7 If mediation is unsuccessful to resolve all issues, the parts of the Claim remaining in dispute shall be subject to applicable procedures outside of this section and the requirements of Public Contract Code § 9204. The Claim resolution procedures in this Section do not preclude the County from requiring arbitration of disputes under private arbitration or the Public Works Contract Arbitration Program, if mediation under this Article does not resolve the parties' dispute.

21.3.8 Following the procedures set forth in this Section 21, including the mediation, if the Claim or any portion of it remains in dispute, the Contractor may file a Claim as provided in Chapter 1 (commencing with § 900) and Chapter 2 (commencing with § 910) of Part 3 of Division 3.6 of Title 1 of the Government Code. If the Government Code claim is denied, Contractor may file an action in court. Such action shall be subject to Public Contract Code Sections 9204 or 20104.4. This Section applies only to claims subject to Public Contract Code Sections 9204 or 20104. If a claim is not subject to Public Contract Code Sections 9204 or 20104, the Contractor's right to file a civil action shall be as otherwise provided by law.

21.4 **Subcontractor Claim(s)**

If a subcontractor or a lower tier subcontractor has a Claim, the Contractor may present to the County a Claim on behalf of a subcontractor or lower tier subcontractor. A subcontractor may request in writing, either on his or her own behalf or on behalf of a lower tier subcontractor, that the Contractor present a Claim for work which was performed by the subcontractor or by a lower tier subcontractor on behalf of the subcontractor. The subcontractor requesting that the Claim be presented to the County shall furnish reasonable documentation as set forth in Section 21 to support the Claim. Within forty-five (45) days of receipt of this written request, the Contractor shall notify the subcontractor in writing as to whether the Contractor presented the Claim to the County, and if the Contractor did not present the Claim, provide the subcontractor with a statement of the reasons for not having done so.

22. Brand or Trade Name – Substitute of Equals

Attention is directed to Standard Specifications Section 6-1.05, "Specific Brand or Trade Name and Substitution".

Reference is made to §3400 of the Public Contracts Code, which is by this reference incorporated herein with like effect as if here set forth in full.

If a Contractor believes he knows of an equal to a specified brand or trade name which is not mentioned in the Contract Documents, then such potential Contractor may so advise Director of TLMA of such fact, giving all relevant information.

Unless the subject article or product is expressly designated for matching others in use in a particular public improvement either completed or in the course of completion, any Contractor may, as part of its bid proposal, include a request for substitution of an item equal to any specified by brand or trade name.

Within 15 calendar days after award of the contract, Contractor may submit to Director of TLMA data substantiating such a request, and the difference, if any, in cost. Director of TLMA shall promptly investigate the request and make a recommendation to County as to equality. The governing body of County shall promptly determine whether the substitute is equal in every respect to the item specified, and approve or deny the request accordingly, and shall notify Director of TLMA of the determination made, who shall advise Contractor in writing of the decision. Unless the request is granted, substitution will not be permitted.

Nothing herein shall authorize a change in the contract price or prevent the use of change orders in the manner provided elsewhere in the Contract Documents.

23. Site Inspection – Effect of Other Improvements Shown and Contractor Procedure

Elsewhere in the Contract Documents reference may be made graphically, descriptively, or both, to the existence or possible existence of other improvements affecting the site and the prosecution of the work such as surface and subsurface utilities, drainage ditches and courses, buildings, fencing, retaining walls, roadways, curbs, trees, shrubs, and similar matters. Such matters are included to be used by Contractor to the extent he deems appropriate. However, it is expressly understood and agreed:

- A. Showing or describing such items does not mean that it is an exhaustive and complete presentation and that as to matters shown or described that they necessarily exist.
- B. All graphic presentations are schematic only unless the contrary is clearly set out elsewhere as to a particular matter.
- C. Whenever in the plans survey markers are shown, boundaries of the site are shown or contour lines are shown, Contractor may assume that such matters are shown in accordance with acceptable standards.

All improvements of the nature described above, whether elsewhere shown or described or not, shall, unless the contrary is elsewhere specifically directed, remain in place, undisturbed and suitably protected during the course of the work.

Whenever, during the course of the work, a subsurface improvement is discovered, which Contractor believes is unknown to County, he shall immediately inform Director of TLMA. Except as elsewhere provided, whenever in the course of the work it becomes apparent that the work cannot proceed without the destruction or relocation of any improvement, whether shown or described or not, Contractor shall immediately cease work affecting such

improvements, notify Director of TLMA as to such circumstance, and await instructions as to how to proceed.

- D. The Contractor shall be required to cooperate fully with all utility forces or forces of other public agencies engaged in relocation, lowering, altering or otherwise rearranging any facilities interfering with the progress of work or installing any facilities thereon.

The Contractor will also be required to cooperate fully with any County or State forces working on or near the project, or requiring access to the work in the performance of their duties.

24. Public Safety

The Contractor shall provide for the safety of traffic and the public in conformance with the provisions in Section 7-1.04, "Public Safety" of the Standard Specifications and these Special Provisions.

The Contractor shall install Type K temporary railing between a lane open to public traffic and an excavation, obstacle or storage area when the following conditions exist:

A. Excavations

The near edge of the excavation is 12 feet or less from the edge of the lane, except:

1. Excavations covered with sheet steel or concrete covers of adequate thickness to prevent accidental entry by traffic or the public.
2. Excavations less than 1 foot deep.
3. Trenches less than 1 foot wide for irrigation pipe or electrical conduit, or excavations less than 1 foot in diameter.
4. Excavations parallel to the lane for the purpose of pavement widening or reconstruction.
5. Excavations in side slopes, where the slope is steeper than 1:4 (vertical: horizontal).
6. Excavations protected by existing barrier or railing.

B. Temporarily Unprotected Permanent Obstacles

The work includes the installation of a fixed obstacle together with a protective system, such as a sign structure together with protective railing, and the Contractor elects to install the obstacle prior to installing the protective system; or the Contractor, for the Contractor's convenience and with permission of the Engineer, removes a portion of an existing protective railing at an obstacle and does not replace such railing complete in place during the same day.

C. Storage Areas

Material or equipment is stored within 12 feet of the lane and the storage is not otherwise prohibited by the provisions of the Standard Specifications and these Special Provisions.

The approach end of Type K temporary railing installed in conformance with the provisions in this Special Provision section "Public Safety" and in Section 7-1.04, "Public Safety" of the Standard Specifications, shall be offset a minimum of 15 feet from the edge of the traffic lane open to public traffic. The temporary railing shall be installed on a skew toward the edge of the traffic lane of not more than 1 foot transversely to 10 feet longitudinally with respect to the edge of the traffic lane. If the 15 feet minimum offset cannot be achieved, the temporary railing shall be installed on the 10 to 1 skew to obtain the maximum available offset between the approach end of the railing and the edge of the traffic lane, and an array of temporary crash cushion modules shall be installed at the approach end of the temporary railing.

Type K Temporary railing shall conform to the provisions in Section 12-3.20, "Type K Temporary Railing" of the Standard Specifications. Type K Temporary Railing, conforming to the details shown on 2018 Standard Plan T3A and T3B, may be used. Type K Temporary Railing fabricated prior to January 1, 1993, and conforming to 1988 Standard Plan B11-30 may be used, provided the fabrication date is printed on the required Certificate of Compliance.

Temporary crash cushion modules shall conform to the provisions in "Temporary Crash Cushion Module" of these Special Provisions, if applicable.

Except for installing, maintaining and removing traffic control devices, whenever work is performed or equipment is operated in the following work areas, the Contractor shall close the adjacent traffic lane unless otherwise provided in the Standard Specifications and these Special Provisions:

Approach Speed of Public Traffic Posted Limit	Work Areas
Over 45 Miles Per Hour	Within 6 feet of a traffic lane but not on a traffic lane
35 to 45 Miles Per Hour	Within 3 feet of a traffic lane but not on a traffic lane

The lane closure provisions of this Section shall not apply if the work area is protected by permanent or temporary railing or barrier.

When traffic cones or delineators are used to delineate a temporary edge of a traffic lane, the line of cones or delineators shall be considered to be the edge of the traffic lane, however, the Contractor shall not reduce the width of an existing lane to less than 10 feet without written approval from the Engineer.

When work is not in progress on a trench or other excavation that required closure of an adjacent lane, the traffic cones or portable delineators used for the lane closure shall be placed off of and adjacent to the edge of the traveled way. The spacing of the cones or delineators shall be not more than the spacing used for the lane closure.

Suspended loads or equipment shall not be moved nor positioned over public traffic or pedestrians.

Payment

Full compensation for conforming to the provisions in this Section, Public Safety, including furnishing and installing temporary railing (Type K) and temporary crash cushion modules, shall be considered as included in the estimated cost for emergency repair work Contract and no additional compensation will be allowed therefor.

25. Extra Work

Section 4-1.05, "Changes and Extra Work" of the Standard Specifications is amended by adding the following:

If, in the opinion of the Engineer, such work cannot reasonably be performed concurrently with other items of work, and if a controlling item of work is delayed thereby, an adjustment of contract time of completion will be made.

26. Noise Control

Noise control shall conform to the provisions in Section 14-8.02, "Noise Control" of the Standard Specifications and these Special Provisions.

Section 14-8.02, "Noise Control", second paragraph, is deleted and replaced with the following:

The noise level from the Contractor's operations, between the hours of 9:00 p.m. and 6:00 a.m., shall not exceed 86 dBA LMax at a distance of 50 feet. This requirement in no way relieves the Contractor from responsibility for complying with local ordinances regulating noise level.

Said noise level requirement shall apply to all equipment on the job or related to the job, including but not limited to trucks, transit mixers or transient equipment that may or may not be owned by the Contractor. The use of loud sound signals must be avoided in favor of light warnings except those required by safety laws for the protection of personnel.

Payment

Full compensation for conforming to the requirements of this Section, Noise Control, shall be considered as included in the estimated cost for emergency repair work Contract and no additional compensation will be allowed therefor.

27. Use, Care and Protection of Premises

Attention is directed to Section 5-1.36, "Property and Facility Preservation" of the Standard Specifications.

At his expense Contractor shall:

- A. Take every precaution against injuries to persons or damage to property.
- B. Comply with regulations governing the use of the property.
- C. Store and suitably protect his apparatus, equipment, materials and supplies in an orderly fashion on site.
- D. Place on the work only such loads as are consistent with the safety of the work.
- E. Effect all cutting, fitting, or patching of his work required to make it conform to the plans and specifications and interrelate with other improvements or except with the consent of Director of TLMA, cut or otherwise alter existing improvements.
- F. Protect and preserve established bench marks and monuments, make no changes in the location of such without the prior written approval of County, replace and relocate any of them which may be lost or destroyed, or which require shifting because of necessary changes in grades or locations. All replacement and relocation work shall be accomplished only after approval of County and under the direct supervision and instruction of Director of TLMA.
- G. Before final payment remove all surplus materials, false work, temporary structures, debris, and similar matter resulting from his operations from the site and to put the site in an orderly condition.
- H. Construct, operate and maintain all passageways, guard fences, lights, barricades and other facilities required for protection by State or municipal laws and regulations and local conditions during the course of the work.
- I. Guard County's property from injury or loss.
- J. Take all reasonable precautions for dust and noise control and generally conduct operations so as not to constitute a nuisance.

- K. The Contractor shall be responsible for the protection of existing signs, fences, concrete curb and gutter and other highway facilities which may be encountered in the roadway. The replacement or repair of any facilities which the County deems necessary as a result of the Contractor's operations shall be done by the Contractor at his own expense and to the satisfaction of the County Transportation Department.

Payment

Full compensation for conforming to the requirements of this Section, Use, Care and Protection of Premises, shall be considered as included in the estimated cost for emergency repair work Contract and no additional compensation will be allowed therefor.

28. Obstructions

Attention is directed to Section 5-1.36C, "Nonhighway Facilities", Section 15, "Existing Facilities" and 51-1.03E(9), "Utility Facilities", of the Standard Specifications and these Special Provisions.

In the event that the utility facilities mentioned within the referenced Standard Specifications and/or Special Provisions are not removed or relocated by the times specified and, if in the opinion of the Engineer, the Contractor's operations are delayed or interfered with by reason of the utility facilities not being removed or relocated by said times, the County will compensate the Contractor for such delays to the extent provided in Section 8-1.07, "Delays" of the Standard Specifications, except as provided in the previous paragraph referenced sections of the Standard Specifications.

29. Removal of Asbestos and Hazardous Substances

When the presence of asbestos or hazardous substances are not shown on the plans or indicated in the specifications and the Contractor encounters materials which the Contractor reasonably believes to be asbestos or a hazardous substance as defined in Section 25914.1 of the Health and Safety Code, and the asbestos or hazardous substance has not been rendered harmless, the Contractor may continue work in unaffected areas reasonably believed to be safe. The Contractor shall immediately cease work in the affected area and report the condition to the Engineer in writing.

In conformance with §25914.1 of the Health and Safety Code, removal of asbestos or hazardous substances including exploratory work to identify and determine the extent of the asbestos or hazardous substance will be performed as Extra Work.

If delay of work in the area delays the current controlling operation, the Contractor will be compensated for the delay in conformance with the provisions in Section 8-1.07, "Delays" of the Standard Specifications.

30. Documents of Contractor

Upon demand, Contractor shall make available to County all documents, information and reports in its possession relevant to the work accomplished or to be accomplished or any demand or claim of Contractor as to County. This includes copies of documents sent by Contractor or others in its possession. Contractor shall further make available to County conformed copies of all documents submitted to the sureties who executed the Performance Bond, or Payment Bond for the purpose of obtaining the sureties' signature, including any guarantee or indemnification made to such surety by others for such purpose. Contractor shall maintain in his possession all documents relative to the work for three years after Notice of Completion.

31. In-Use Off-Road Diesel-Fueled Fleet Certificate Of Reported Compliance

Valid Certificates of Reported Compliance as described in California Code of Regulations, title 13, section 2449(n) for fleets of vehicles subject to 13 CCR section 2449 are required for this project, as applicable.

32. Responsibility of Contractor to Act in an Emergency

In case of an emergency which threatens loss or injury to property or life, Contractor shall act without previous instructions as the situation may warrant. Contractor shall notify Director of TLMA immediately thereafter. Any compensation claimed by Contractor, together with substantiating documentation shall be submitted to County via Director of TLMA.

33. Final Inspection – Notice of Completion

When the work is ready for final inspection, County shall cause the work to be inspected and subjected to such tests as seem to it to be required for the purpose of determining if the work is complete in every respect.

At a meeting of the governing body of County held within ten (10) days after final inspection, the governing body shall consider the facts developed at the inspection. If it is found that the work is apparently complete in every respect, County will accept the work and a Notice of Completion will be recorded.

As between the parties, the recordation of the Notice of Completion, unless recorded because of a cessation of labor, means only that the time for final payment and the commencement of the guarantee period commences to run.

34. Dust Abatement

Dust control shall conform to Section 10-5, “Dust Control”, Section 14-9.02, “Air Pollution Control”, Section 10-6, “Watering”, and Section 18, “Dust Palliative” of the Standard Specifications, Rules no. 401, 402, 403 and 403.1 of the South Coast Air Quality Management District (AQMD), Riverside County Code, Chapter 8.52, “Fugitive Dust Reduction Program For Coachella Valley” (if project location is within the Coachella Valley), all other applicable Federal and State laws, and the requirements set forth herein.

The Contractor is cautioned that failure to control fugitive dust may result in fines being levied by the South Coast Air Quality Management District to both the Contractor and the County, as Owner. The Contractor shall be fully responsible for payment of all fines pertaining to air pollution control violations, resulting from Contractor’s operations related to the construction contract, which may be levied against both the Contractor and the County by the AQMD or other regulatory agencies. The Contractor’s attention is directed to Section 7-1.02, “Laws” and Section 7-1.02A of the Standard Specifications. The cost of all fines levied against the County will be deducted from any moneys due or which may become due to the Contractor, unless other payment arrangements are made by the Contractor.

Dust control of all of the Contractor’s operations is required 24 hours per day, 7 days a week for the duration of the contract, and until the disturbed soil is permanently stabilized. The Contractor shall take every precaution to prevent emissions of fugitive dust from the project site, from locations of stockpiled materials, from unpaved driving surfaces, from haul vehicles, from inactive construction areas, and from all other operations of the Contractor. The Contractor shall plan for and carry out proper and efficient measures to prevent their operations from producing dust in amounts damaging to property or which constitute a public nuisance, or which cause harm to persons living or working in the vicinity of the work. Particular concern of emissions is PM10 particles. PM10 particles are fine particulate matter of 10 microns or less which are associated with sickness and death from respiratory disease.

The Contractor shall furnish and post dust mitigation signs, which shall be, at a minimum, in accordance with the “AQMD Recommendations”, attached hereto (See Appendix). Additional copies are available upon request from the Engineer. The sign shall include the Contractor’s phone number which shall be maintained on a 24 hour basis. The sign message, size and design, including any deviations from the signage recommendations, shall be approved by the Engineer prior to fabrication.

The Contractor shall respond to complaints by mobilizing equipment and personnel at the construction site within 2 hours of each complaint to control fugitive dust.

Attention is directed to AQMD Rule 403.1, which applies to all contracts within the Coachella Valley Area of Riverside County. That AQMD Rule requires the Contractor to take specified dust control actions when prevailing wind speeds exceed 25 miles per hour. Wind forecasts, AQMD Rules and other related information are provided by AQMD at 1-800-CUT-SMOG and at www.aqmd.gov.

Any days on which the Contractor is prevented from working, due to the requirements of AQMD Rules, will be considered as non-working days, in accordance with Section 8-1.05, "Time" of the Standard Specifications.

The Contractor shall utilize the "Best Available Control Measures" of controlling fugitive dust, as prepared by the AQMD. For projects within the Coachella Valley, the "Reasonably Available Control Measures" may be employed, if effective within the context of the AQMD rules. However, if fugitive dust crosses the project boundary, more effective control measures, including the "Best Available Control Measures" shall be implemented.

A site-specific fugitive dust control plan shall be submitted to the Engineer for review and approval at least 10 days prior to the start of construction. Additionally, for projects outside of the Coachella Valley which meet the criteria for AQMD plan approval, the Contractor shall submit the dust control plan to AQMD for approval. AQMD plan submittal criteria is defined in AQMD Rule 403 as being for projects that will have disturbed surface area in excess of 100 acres, or for projects with a scope of work which requires the movement of more than 10,000 cubic yards of soil on each of any three working days.

A sample plan and other pertinent information is attached, and additional copies are available from the Engineer upon request. The fugitive dust control plan shall include the "Reasonably Available Control Measures" and "Best Available Control Measures" of controlling fugitive dust, as may be appropriate and necessary, including but not limited to watering, application of chemical dust suppressants, wind fencing, covering of haul vehicles, haul vehicle bed-liners, covering or chemically stabilizing stored materials, phased grading, planting of vegetation, the use of a 24 hour environmental observer, and track-out controls at locations where unpaved construction accesses intersect with paved roads. The use of chemical stabilizers, which are approved by all environmental regulatory agencies, and the use of reclaimed water is encouraged. If water is intended as a primary dust control tool, the dust control plan shall provide for at least one 2,000 gallon water truck for every 4 acres of disturbed soil, unless otherwise approved by the Engineer.

If the Construction Engineer determines that the project scope and the forecasted weather conditions are such that the Contractor's work is unlikely to be a source of dust emissions, the Construction Engineer has the authority to waive the requirements for submittal of a dust control plan and for placement of the dust control signs described herein. However, the Contractor's responsibilities for the control of fugitive dust and the other requirements of this Section may not be waived.

A completion notice will not be filed, and the final payment will not be made to the Contractor until the areas of disturbed soil on the construction site, including roadway shoulders, are suitably stabilized for long term control of fugitive dust.

The successful Contractor shall attend an AQMD PM10 Dust Control Program training session, and furnish evidence of attendance to the Engineer. Attendance at AQMD training seminars can be scheduled through AQMD at 1-866-861-DUST (1-866-861-3878) or by email

to dustcontrol@aqmd.gov. Current AQMD certification of previous attendance will be accepted.

At that training session, the successful Contractor will be furnished with the AQMD prepared Rule 403 and Rule 403.1 implementation handbooks, which include the “Best Available Control Measures” and “Reasonably Available Control Measures”, and other associated information, including a listing of suggested dust control related devices, materials and chemicals.

The signature of the Contractor on the Contract constitutes acknowledgement by the Contractor of the dust control requirements established by law and described herein, and the enforceability of those requirements.

Payment

When the contract includes a work item for Dust Abatement, full compensation for conformance with these dust abatement requirements, including labor, equipment, materials, developing water supply and incidentals, shall be paid at the lump sum price for Dust Abatement, and no additional compensation will be allowed therefor.

When the contract does not include a work item for Dust Abatement, full compensation for conformance with these dust abatement requirements, including labor, equipment, materials, developing water supply and incidentals, shall be considered as included in the estimated cost for emergency repair work Contract and no additional compensation will be allowed therefor.

SPECIAL PROVISIONS

TABLE OF CONTENTS

DIVISION 0 COUNTY PROVISIONS.....	1
00 COUNTY MISCELLANEOUS	1
00-1.01 PROJECT DESCRIPTION:.....	1
00-1.02 SPECIFICATIONS	2
00-1.03 TIME OF COMPLETION:.....	2
00-1.04 LIQUIDATED DAMAGES:.....	2
00-1.05 ADDITIONAL INSURANCE REQUIREMENTS, ADDITIONAL INSURED LIST:	2
00-1.06 ENCROACHMENT PERMIT:.....	3
00-1.07 PROSECUTION AND PROGRESS:.....	3
00-1.08 COOPERATION:.....	4
00-1.09 OBSTRUCTIONS.....	4
00-1.10 DISPOSAL OF EXCESS EXCAVATION OR MATERIALS:	6
00-1.11 PROJECT APPEARANCE:.....	6
00-1.12 MISCELLANEOUS WORK AS DIRECTED:	7
DIVISION I GENERAL PROVISIONS.....	8
2 BIDDING	8
4 SCOPE OF WORK	8
5 CONTROL OF WORK	8
6 CONTROL OF MATERIALS	9
DIVISION II GENERAL CONSTRUCTION	9
10 GENERAL	9
12 TEMPORARY TRAFFIC CONTROL	9
13 WATER POLLUTION CONTROL	10
14 ENVIRONMENTAL STEWARDSHIP	11
DIVISION III EARTHWORK AND LANDSCAPE	13
17 GENERAL	13
19 EARTHWORK.....	14
DIVISION IV SUBBASES AND BASES.....	16
26 AGGREGATE BASES	16
DIVISION V SURFACINGS AND PAVEMENTS	17
39 ASPHALT CONCRETE.....	17
DIVISION V STRUCTURES	31
51 CONCRETE STRUCTURES	31
52 REINFORCEMENT	32
DIVISION VII DRAINAGE FACILITIES.....	32
65 CONCRETE PIPE.....	32
DIVISION VIII MISCELLANEOUS CONSTRUCTION	34
72 SLOPE PROTECTION.....	34
73 CONCRETE CURBS	35
DIVISION XI MATERIALS.....	36
96 GEOSYNTHETICS	36

DIVISION 0 COUNTY PROVISIONS

00 COUNTY MISCELLANEOUS

00-1.01 PROJECT DESCRIPTION:

**Emergency Road and Storm Drain Damage Repair Work
Pedley Road, Emergency Access Road
Western Riverside County/City Animal Shelter
Project No. D4-0135**

Attention is directed to Section 4 "SCOPE OF WORK" of the Standard Specifications.

Work performed will be paid as force account work, as described in Section 9-1.04 of the Caltrans Standard Specifications. The contract and procedures will be in accordance with the County of Riverside's emergency contract procedures, as directed in County Resolution 2019-035.

In general, this project consists of storm damage repair work on the emergency access road for Western Riverside County/City Animal Shelter in the City of Jurupa Valley. As Transportation Departments keeps assessing damages, work may be added to this location, as necessary.

Riverside County Department of Animal Services, located in the city of Jurupa Valley, has an emergency access road at the Western Riverside County/City Animal Shelter that has been impacted by the recent rains, causing scouring at the storm drain culvert outlet. The access road encountered major erosion including partial roadway collapse that left a large cavity, eroded the side slope, and undermined the portions of the existing reinforced concrete pipes that resulted in collapsed culvert concrete headwall and pipes.

The driveway is unsafe for vehicular/pedestrian access; therefore, it is imperative for the County to safely repair the drainage system and the driveway.

Work performed will be paid as force account work, as described in Section 9-1.04 of the Caltrans Standard Specifications and markup percentages as proposed by the contractor.

Repair work will include the following tasks:

1. Emergency work assessment meeting at project location,
2. Mobilization and demobilization,
3. Environmental Stewardship,
4. Removal and proper disposal of debris,
5. Safely remove and replace the damaged portion of the curb,
6. Diverting existing water flows,
7. Grading and earthwork,
8. Removal of broken concrete pipes and installation of new concrete pipes and concrete collars
9. Placing compacted fill in the undermined and eroded cavities, reestablish the cross-side slope for installation on new concrete pipes and new concrete headwall,
10. Construction of a new concrete headwall and cutoff wall,
11. Installation of rock slope protection (riprap)
12. Pavement repairs which will include saw cutting damaged areas,
13. Placing new Hot Mix Asphalt over Aggregate Base over the spalled asphalt at the collapsed roadway portion
14. Disposal of excess excavation or unusable materials,
15. Traffic control (changeable message sign boards, road closure signs, delineators, etc.),
16. Additional work as necessary and as directed by the Engineer.

00-1.02 SPECIFICATIONS

This project shall conform to the requirements of the **2018** edition of the Standard Specifications and Standard Plans as issued by the State of California Department of Transportation.

00-1.03 TIME OF COMPLETION:

The Contractor shall diligently prosecute the work to completion before the expiration of **25 Working Days** from the date stated in the "Notice to Proceed".

00-1.04 LIQUIDATED DAMAGES:

There are no liquidated damages assigned to this project.

00-1.05 ADDITIONAL INSURANCE REQUIREMENTS, ADDITIONAL INSURED LIST:

In addition to the requirements of General Conditions Section 4, "Insurance and Hold Harmless" of these contract documents, the Contractor's Certificate of Insurance and additional insured endorsements for the project shall name the following listed entities as additional insured under the Contractor's general liability, excess liability, and auto liability insurance policies, and each listed entity shall be named on the Waiver of Subrogation for the Contractor's Workers Compensation policy.

1. County of Riverside, its Agencies, Districts, Special Districts and Departments, their respective directors, officers, Board of Supervisors, elected and appointed officials, employees, agents, and representatives.
2. City of Jurupa Valley, their elected and appointed officials, directors, employees, agents, and representatives.
3. Riverside County Department of Animal Services (Western Riverside County/City Animal Shelter), their elected and appointed officials, directors, employees, agents, and representatives.

Each of the above listed entities shall also be held harmless, in accordance with the requirements of General Conditions Section 4, "Insurance and Hold Harmless" of these contract documents.

Payment

Full compensation for compliance with the requirements of this Section will be paid for on a force account basis, in accordance with Section 9-1.04, Force Account, of the Standard Specifications, and proposed markup percentages for the work performed.

00-1.06 ENCROACHMENT PERMIT:

It shall be the responsibility of the Contractor to obtain Encroachment Permit (non-fee) from the following agencies for the work done within their jurisdiction prior to commencing any work.

- City of Jurupa Valley

Permit may be required when placing any traffic control devices, and/or for the work done within the City's Right of Way. Permit must be issued by the City prior to commencing any work.

Contractor to submit Traffic Control plans to City of Jurupa Valley for review and approval prior to issuance of Encroachment Permit.

All work shall comply with the City of Jurupa Valley issued permits.

00-1.07 PROSECUTION AND PROGRESS:

Attention is directed to the provisions in Section 8-1.04, "Start of Job Site Activities", Section 8-1.05 "Time" of the Standard Specifications and these Special Provisions.

Standard Specification Section 8-1.04B, "Standard Start" is modified to read as follows:

The Contractor shall begin work within the calendar days stated within the written "Notice to Proceed".

The Contractor shall notify the Engineer, in writing, of the Contractor's intent to begin work at least 24 hours before work is begun. If the project has more than one (1) location of work, Contractor shall submit a separate notice for each location. The notice shall be delivered to the Transportation Department's Engineer and shall specify the date the Contractor intends to start at said location.

Should the Contractor begin work in advance of receiving a written "Notice to Proceed", any work performed by the Contractor in advance of the date stated in the "Notice to Proceed" shall be considered as having been done by the Contractor at his own risk and as a volunteer and subject to the following:

- A. The Contractor shall, on commencing operations, take all precautions required for public safety and shall observe all the provisions in the Specifications and the Special Provisions.
- B. All work done according to the Contract, prior to the issuance of the "Notice to Proceed", will be considered authorized work and will be paid for as provided in the contract.
- C. The Contractor shall not be entitled to any additional compensation or an extension of time for any delay, hindrance or interference caused by or attributable to commencement of work prior to the issuance of the "Notice to Proceed".

00-1.08 COOPERATION:

Attention is directed to Section 5-1.20 "Coordination with Other Entities" of the Standard Specifications and these Special Provisions.

Attention is directed to Section 5-1.36C, "Nonhighway Facilities," of the Standard Specifications.

Should construction be under way by other forces or by other Contractors within or adjacent to the limits of the work specified or should work of any other nature be under way by other forces within or adjacent to those limits, the Contractor shall cooperate with all the other Contractors or other forces to the end that any delay or hindrance to their work will be avoided. The right is reserved to perform other or additional work at or near the site (including material sources) at any time, by the use of other forces.

The Contractor shall communicate on a regular basis with the other Contractors, agencies, and utility companies responsible for the other work near vicinity of these projects.

Each Contractor shall be responsible to the other for all damage to work, to persons or property caused to the other by their operations, and for loss caused the other due to unnecessary delays or failure to finish the work within the time specified for completion.

Payment

Full compensation for cooperating and coordinating with other Contractors shall be considered as included in the prices paid for other force account items of work using the proposed markup percentages and no additional compensation will be allowed therefor.

00-1.09 OBSTRUCTIONS

Attention is directed to General Condition's item 28, "Obstructions".

Attention is directed to Sections 5-1.36, "Property and Facility Preservation" and Section 15, "Existing Facilities" of the Standard Specifications.

Existing utility and privately-owned facilities shall be protected in accordance with Section 5-1.36, "Property and Facility Preservation" and these Special Provisions. The Contractor is also responsible to protect those facilities that are to be relocated by others prior to or during construction, and shall protect those facilities in both their existing and their ultimate locations. The Contractor shall cooperate with owners and their Contractors of utility and privately-owned facilities, for the relocation of said facilities, in accordance with Section 5-1.20, "Coordination with other Entities" of the Standard Specifications.

All water valves and covers, gas valves and covers, sewer manholes, survey monuments, survey markers and any other utility appurtenances shall be protected in place.

The Contractor's attention is directed to the existence of certain underground facilities that may require special precautions be taken by the Contractor to protect the health, safety and welfare of workmen and the public. Facilities requiring special precautions include, but are not limited to: conductors of petroleum products, oxygen, chlorine, and toxic or flammable gases; natural gas in pipe lines greater than 6 inches in diameter or pipe lines operating at pressures greater than 60 psi (gage); underground electric supply system conductors or cables either directly buried or in duct or conduit which do not have concentric neutral conductors or other effectively grounded metal shields or sheaths; and underground electrical conductors with potential to ground of more than 300 volts.

The Contractor shall notify the Engineer at least twenty-four hours prior to performing any work in the vicinity of such facilities.

Attention is directed to the requirements of Government Code Sections 4216-4216.9 pertaining to existing utility facilities.

The Contractor shall assume that every house, building and lot within the project limits has utility service pipes and conductors (laterals), and that utility main and trunk facilities exist within the project limits. The Contractor shall determine if it is warranted to determine the exact location of these utility service laterals and existing main lines, unless directed by the Engineer to pot-hole at specific locations, or as otherwise required herein. The Contractor will not be directly reimbursed for determining the exact location of the utility main lines or services laterals. Any damage to existing main lines or service laterals for which pot-holing was not performed shall be considered damage due to not using reasonable care and the damage shall be repaired at the Contractor's expense.

The Contractor shall conduct his operations with the assumption that underground utility facilities exist within the project limits. The Contractor shall exercise caution and best construction practices for safety and for protection of underground facilities. The approximate locations of underground utility facilities, as shown on the plans, are based on information provided by the respective owners, listed below. The Contractor shall also utilize the markings of the regional notification center (Underground Service Alert), and above-ground utility appurtenances to determine the existence and approximate location of underground utilities.

No excavation shall be made within 4 feet of any underground utilities, as shown on the plans and/or marked by Underground Service Alert, unless and until such utilities have been positively located as to horizontal and vertical position. This requirement applies to all underground electric, natural gas, toxic or flammable gas, chlorine, oxygen or petroleum facilities.

The Contractor is advised that abandoned or active utility facilities may exist within the project limits, which were not known to the design engineer and which are not shown on the plans. The Contractor shall immediately inform the Engineer if any such utility facilities are encountered within the project limits so that resolution can be initiated if a conflict exists. Any utility facilities that have been encountered, and which have been determined by the Engineer to be abandoned, shall be cut and capped and disposed-of as directed by the Engineer. Removal, capping and disposal of abandoned utility conduits, conductors, pipe and other facilities shall be considered as incidental excavation, and its compensation shall be considered included in the contract unit price paid for Clearing and Grubbing or Excavation, and no additional compensation will be allowed therefor.

In the event that the Contractor encounters abandoned or active Asbestos Cement pipe, or any other utility facility containing or suspected of containing asbestos, the Contractor shall immediately notify the Engineer, and will cease work in the vicinity of the encountered material. The Engineer will endeavor to have any such conflicting facilities removed or relocated by the owner of the facilities. If so ordered by the Engineer, the Contractor or his sub-contractor will remove and dispose of abandoned utility facilities containing or suspected of containing asbestos accordance with the health and safety requirements for handling the material, using properly trained and licensed personnel. Said work shall be considered as extra work.

Forty-eight hours prior to beginning construction, the Contractor shall notify the following agencies:

Underground Service Alert

800-227-2600

Payment

Full compensation for all costs, including labor, equipment, materials and incidentals, required to comply with the requirements of this section above, including protection of water valves and covers, gas valves and covers, sewer manholes, survey monuments, survey markers and any other utility appurtenances, shall be considered as included for other force account items of work using the proposed markup percentages and no additional compensation will be allowed therefor.

00-1.10 DISPOSAL OF EXCESS EXCAVATION OR MATERIALS:

Attention is directed to Section 17-2.03D, "Disposal of Materials", of the Standard Specifications and these Special Provisions.

Excess earth excavation, pavement grindings and other excess materials resulting from construction operations shall be disposed of by the Contractor outside of the highway right of way.

When any material is to be disposed of outside the highway right of way, and the County has not made arrangements for the disposal of such material, the Contractor shall first obtain written authorization from the property owner on whose property the disposal is to be made, and obtain all required permits from the jurisdictional agency(s) for said work, and Contractor shall file with the Engineer said authorization or a certified copy thereof together with a written release from the property owner absolving the County from any and all responsibility in connection with the disposal of material on said property. If the disposal of materials is to be made at an established disposal facility that is available for public use, the Contractor shall retain all authorizations and receipts from said disposal facility and shall provide copies to the Engineer upon request.

Payment

Full compensation for all costs involved in disposing of materials as specified in this section, including all costs of hauling, shall be considered as included in the estimated cost for emergency repair work Contract and no additional compensation will be allowed therefor.

00-1.11 PROJECT APPEARANCE:

Attention is directed to General Condition 27, "Use, Care and Protection of Premises."

The Contractor shall maintain a neat appearance to the worksite. The parkway between the pavement and property line is generally maintained free of trash and debris by the adjacent property owners. The Contractor shall inform all workers to be respectful of the property owners and maintaining the parkways and street adjacent to their homes.

The Contractor must maintain a neat appearance to the work.

In areas visible to the public, the following shall apply:

- A. When practicable, broken concrete and debris developed during clearing and grubbing shall be disposed of concurrently with its removal. If stockpiling is necessary, the material shall be removed or disposed of weekly.

DIVISION I GENERAL PROVISIONS

2 BIDDING

Add to Section 2-1.06A:

Amendments to the 2018 Standard Specifications (Revised Standard Specifications) for this project, dated **April 15, 2022**, are incorporated herein. This document is available upon request at the office of the Department.

4 SCOPE OF WORK

Refer to section 00-1.01 of these Special Provisions.

5 CONTROL OF WORK

Replace section 5-1.26 Construction Surveys with the following:

5-1.26 Construction Survey

5-1.26A General

County surveyors will establish external primary survey control monuments and/or marks to be used throughout the construction period. These control monuments and marks are to be protected by Contractor and will be used to set construction stakes and/or marks. The control marks will also be used to make verification surveys at various stages of work.

Survey monuments, stakes and marks are set per the County's Survey Manual.

Contractor must submit a written request for County furnished construction staking before, or immediately after, area to receive staking is ready for the installation of the construction stakes.

5-1.26B Survey Request

The County will provide Contractor with a survey request form. Survey staking requests must be received from Contractor a minimum of two (2) Business Days prior to the installation of the requested construction staking. The County shall receive written survey request on operating Business Day, Monday through Thursday, and prior to 4:00 p.m. Requests received after 4:00 p.m. or on any other day, shall be considered as submitted at 7:30 a.m. the next Business Day.

5-1.26C Preserve Survey Stakes and Marks

Contractor must preserve primary survey control monuments and marks, construction stakes and construction marks placed by the County. Survey costs are incurred by the County; however, if the Contractor fails to protect and/or destroys these survey items, the County shall replace them at the County's earliest convenience and deduct the cost of replacement from payment due to the Contractor.

14 ENVIRONMENTAL STEWARDSHIP

14-1 GENERAL

Add to the end of section 14-1.02, Environmentally Sensitive Area:

Environmentally Sensitive Areas (ESA) exist on this project.

TYPE ESA TEMPORARY FENCE:

Before starting job site activities, Type ESA temporary fence shall be installed at the locations shown on the plans and as directed by the Engineer and in consultation with the Designated Biologist(s), in conformance with Section 16-2.03, Temporary High-Visibility Fences, of the Standard Specifications, and pursuant to CDFW 1602 permit measure 2.4, Delineate Work Area Boundary and its exhibits 2a-2k.

Biologist services will be provided by Riverside County staff.

The Type ESA fence boundaries shown are approximate; the County marks the exact Type ESA fence boundaries on the ground.

Payment

Full compensation for compliance with the requirements of this Section will be paid for on a force account basis, in accordance with Section 9-1.04, Force Account, of the Standard Specifications, and proposed markup percentages for the work performed for doing all the work involved in installing the temporary high-visibility fence (Type ESA), complete in place, including maintenance, removal and disposal of discarded materials, and backfilling and repairing holes, depressions and other ground disturbance, as specified in the Standard Specifications and these Special Provisions, and as ordered by the Engineer.

14-2 CULTURAL RESOURCES

Add to Section 14-2.03, Archaeological Resources:

ARCHAEOLOGICAL RESOURCES

14-2.03A General

Section 14-2.03, "Archeological Resources" applies if cultural resources are discovered at the job site. Do not disturb the resources and immediately:

1. Stop all work within a 100-foot radius of the discovery.
2. Protect the discovery area
3. Notify the Engineer.

The Department will investigate. Do not move cultural resources or take them from the job site. Do not resume work within the discovery area until authorized.

If human remains are encountered, State Health and Safety Code Section 7050.5 states that no further disturbance shall occur until the County Coroner has made a determination of origin and disposition pursuant to Public Resources Code Section 5097.98. The County Coroner must be notified of the find immediately. If the remains are determined to be prehistoric, the Coroner will notify the NAHC, which will determine and notify a Most Likely Descendant (MLD). With the permission of the landowner or his/her authorized representative, the MLD may inspect the site of the discovery. The MLD shall complete the inspection within 48 hours of notification by the NAHC. The MLD may recommend scientific removal and nondestructive analysis of human remains and items associated with Native American burials.

In the event that any damage occurs to any cultural resource, the Contractor shall bear the full cost of resource damage evaluation and restoration, and such payment shall not relieve Contractor from civil or criminal remedies otherwise provided by law.

14-6 BIOLOGICAL RESOURCES

Add to Section 14-6.03B Bird Protection:

14-6.03B Bird Protection

14-6.03B(1) General

Bird Protection shall conform to Section 14-6.03B "Bird Protection" of Standard Specifications, these Special Provisions and as directed.

Regulatory Requirements

Attention is directed to the Federal Migratory Bird Treaty Act (15 USC 703-711) 50 CFR Part 21 and 50 CFR Part 10, and the California Department of Fish and Game Code Sections 3503, 3513 and 3800, that protect migratory birds, their occupied nests, and their eggs from disturbance or destruction.

Ground disturbance, tree, shrub and/or vegetation removal that occurs between February 1st and August 31st will not commence until a preconstruction survey for nesting birds has verified that no active nests have been located or the Engineer has approved the beginning of work. If an active nest is located, construction within 500 feet of the nest must be avoided until the nest has been vacated and the young are independent of their parents.

The nesting survey will be provided by Riverside County staff.

Between February 1st and August 31st, the Contractor shall notify the Engineer 10 working days prior to beginning work disturbing structures, the ground or vegetation.

The Contractor shall use exclusion techniques directed by the Engineer to prevent migratory birds from nesting in trees within the project limits.

If evidence of bird nesting is discovered, the Contractor shall not disturb the nesting birds or nests until the birds have naturally left the nests. If evidence of migratory bird nesting is discovered after beginning work, the Contractor shall immediately stop work within 500 feet of the nests and notify the Engineer. Work shall not resume until the Engineer provides a written notification that work may begin at or adjacent areas of the discovered bird nest locations.

Attention is directed to Section 8-1.06, "Suspensions" of the Standard Specifications.

Nothing in this section shall relieve the Contractor from providing for public safety in conformance with the provisions in Section 7-1.04, "Public Safety" of the Standard Specifications.

Payment

Full compensation for compliance with this section shall be considered as included in the contract price paid for the various items of work and no additional compensation will be allowed therefor.

.....

DIVISION III EARTHWORK AND LANDSCAPE

17 GENERAL

17-2 CLEARING AND GRUBBING

Add to section 17-2.01, General, CLEARING AND GRUBBING:

Clearing and grubbing activities shall include but not be limited to **removing and disposing of mud sediment, rocks and boulders, trash, debris, organic material, and grading areas in and adjacent to and within the footprint of the project.**

Trees and bushes including tree stumps and roots shall be removed as shown on the plans and as directed by the Engineer.

Removed trees, trimmings, vegetation, and debris shall be the property of the Contractor and shall be disposed of by the Contractor, as provided in Section 17-2.03D, "Disposal of Materials" of the Standard Specifications and Section 00-1.10, Disposal of Excess Excavation or Materials, of these Special Provisions.

Any tree or bush removal or trimming between February 1st and August 31st will require a preconstruction survey for nesting birds. The Contractor shall schedule accordingly.

The nesting survey, if required, will be provided by Riverside County staff.

Regulatory Requirements

Attention is directed to the Federal Migratory Bird Treaty Act (15 USC 703-711) 50 CFR Part 21 and 50 CFR Part 10, and the California Department of Fish and Game Code Sections 3503, 3513 and 3800, that protect migratory birds, their occupied nests, and their eggs from disturbance or destruction.

Construction

Ground disturbance, tree, shrub and/or vegetation removal that occurs between February 1st and August 31st will not commence until a preconstruction survey for nesting birds has verified that no active nests have been located or the Engineer has approved the beginning of work. If an active nest is located, construction within 500 feet of the nest must be avoided until the nest has been vacated and the young are independent of their parents.

Between February 1st and August 31st, the Contractor shall notify the Engineer 10 working days prior to beginning work disturbing structures, the ground or vegetation.

The Contractor shall use exclusion techniques directed by the Engineer to prevent migratory birds from nesting on the ground, on structures or in trees, shrubs or other vegetation within the project limits.

If evidence of bird nesting is discovered, the Contractor shall not disturb the nesting birds or nests until the birds have naturally left the nests. If evidence of migratory bird nesting is discovered after beginning work, the Contractor shall immediately stop work within 500 feet of the nests and notify the Engineer. Work shall not resume until the Engineer provides a written notification that work may begin at or adjacent areas of the discovered bird nest locations.

Attention is directed to Section 8-1.06, "Suspensions" of the Standard Specifications.

Nothing in this section shall relieve the Contractor from providing for public safety in conformance with the provisions in Section 7-1.04, "Public Safety" of the Standard Specifications.

Activities controlled by the Contractor, except cleanup or other required work, shall be confined within the graded areas of the roadway.

Before final inspection of the work, the Contractor shall clean the highway, material sites and all ground occupied by the contractor in connection with work of all rubbish, excess materials, falsework, temporary structures and equipment. All parts of the work site shall be left in a neat and presentable condition.

Nothing herein, however, shall require the Contractor to remove warning, regulatory and guide signs prior to formal acceptance by the director.

Replace Section 17-2.04 with:

Payment

Full compensation for compliance with the requirements of this Section, including but not limited to **removing and disposing of mud sediment, rocks and boulders, trash, debris, organic material, and grading areas in and adjacent to and within the footprint of the project**, will be paid for on a force account basis, in accordance with Section 9-1.04, Force Account, of the Standard Specifications, for the work performed.

Add to the section 17-2.03D "Disposal of Material":

Before final inspection of the work, the Contractor shall clean the highway, material sites and all ground occupied by the contractor in connection with work of all rubbish, excess materials, falsework, temporary structures and equipment. All parts of the work shall be left in a neat and presentable condition.

Nothing herein, however, shall require the Contractor to remove warning, regulatory and guide signs prior to formal acceptance by the director.

Nothing in this section shall relieve the Contractor from providing for public safety in conformance with the provisions in Section 7-1.04, "Public Safety" of the Standard Specifications.

19 EARTHWORK

19-2 ROADWAY EXCAVATION

Add to Section 19-2.01 General:

Roadway Excavation

Roadway Excavation shall conform to the provisions of Section 19 "Earthwork" of the Standard Specifications and these Special Provisions.

Roadway excavation shall include but not limited to:

- Sawcut of existing asphalt concrete as directed by the Engineer
- Excavation and removal of existing asphalt concrete roadway to the depths as directed by the Engineer
- Moisture condition, grade and compaction of sub-grade to 95%
- Grading of any areas to drain to the nearest drainage facilities

Ground asphalt concrete shall not be used at the surface of shoulders.

At road connections and at limits of asphalt concrete paving, existing pavement shall be header cut as directed by the Engineer. Full compensation for furnishing all labor, tools and doing all the work necessary including grinding, and sawcutting shall be considered as included in the contract prices paid per ton for the various asphalt concrete items and no additional compensation will be allowed therefor.

Existing pavement, including any base material shall be cut back to neat lines and removed as shown on the plans or as directed by the Engineer. Excess material will become the property of the Contractor and will be

DIVISION V SURFACINGS AND PAVEMENTS

39 ASPHALT CONCRETE

Replace section 39-2 HOT MIX ASPHALT with the following:

39-2.01 Hot Mix Asphalt

This work includes producing and placing Type A Hot Mix Asphalt (HMA) **Type A**. Comply with the specifications for HMA under Section 39, "Asphalt Concrete" of the Standard Specifications and these Special Provisions. All other requirements of Section 39 shall apply unless otherwise modified or replaced in these Special Provisions.

The type of hot mix asphalt will be shown on the plans or specified in the Special Provisions.

39-2.01(1a) Material

39-2.01(1a.1) Prime Coat

Liquid asphalt for prime coat shall be Grade SC-70. Prime coat shall be applied only to those areas designated by the Engineer. The application rate shall be 0.20 gallon per square yard of surface covered. The exact rate and number of applications will be determined by the Engineer.

39-2.01(1a.2) Tack Coat

Asphaltic emulsion for paint binder (tack coat) shall conform to the provisions in Section 94, "Asphaltic Emulsion" of the Standard Specifications for the rapid-setting or slow-setting type and grade approved by the Engineer. Grade SS1h shall be used if not otherwise specified. Tack coat shall be applied to all vertical surfaces of existing pavement, curbs, gutters, and construction joints in the surfacing against which additional material is to be placed, to a pavement to be surfaced, and to other surfaces designated in the Special Provisions. The application rate shall be from 0.02 to 0.10 gallon per square yard of surface covered. The exact rate and number of applications will be determined by the Engineer. Application of tack coat shall meet the provisions in Section 39-2.01C(3)(f) of the Standard Specifications.

39-2.01(1a.3) Asphalt Binder

Performance grade (PG) asphalt binder shall conform to the provisions of Section 92, "Asphalt Binders" of the Standard Specifications.

The Contractor shall furnish asphalt in conformance with the State of California Department of Transportation's "Certification Program for Suppliers of Asphalt." The Department maintains the program requirements, procedures, and a list of approved suppliers at the State of California Department of Transportation's METS web site.

The grade for asphalt binder shall be **PG 64-10**.

39-2.01(1a.4) Aggregate

Aggregate shall be clean and free from decomposed materials, organic material, and other deleterious substances.

The aggregate gradation for Type A HMA shall be within the target value (TV) limits for the specified sieve sizes shown in the following tables.

**Aggregate Gradation
(Percentage Passing)**

1-inch Type A HMA

Sieve sizes	TV limits	Allowable tolerance
1"	100	--
3/4"	88–93	TV ± 5
1/2"	72–85	TV ± 6
3/8"	55–70	TV ± 6
No. 4	35–52	TV ± 7
No. 8	22–40	TV ± 5
No. 30	8–24	TV ± 4
No. 50	5–18	TV ± 4
No. 200	3.0–7.0	TV ± 2

3/4-inch Type A HMA

Sieve sizes	TV limits	Allowable tolerance
1"	100	--
3/4"	90–100	TV ± 5
1/2"	70–90	TV ± 6
No. 4	45–55	TV ± 7
No. 8	32–40	TV ± 5
No. 30	12–21	TV ± 4
No. 200	2.0–7.0	TV ± 2

1/2-inch Type A HMA

Sieve sizes	TV limits	Allowable tolerance
3/4"	100	—
1/2"	95–99	TV ± 6
3/8"	75–95	TV ± 6
No. 4	55–66	TV ± 7
No. 8	38–49	TV ± 5
No. 30	15–27	TV ± 4
No. 200	2.0–8.0	TV ± 2

The aggregate shall conform to the following quality requirements prior to the addition of asphalt binder.

Aggregate Quality Requirements

Quality Characteristic	Test Method	HMA Type	
		HMA-A	RHMA-G
Percent of crushed particles ^a Coarse aggregate (% min.) One fractured face Two fractured faces	CT 205	90	--
Fine aggregate (Passing No. 4 sieve and retained on No. 8 sieve.) (% min) One fractured face		75	90
Los Angeles Rattler (% Max.) ^a Loss at 100 rev. Loss at 500 rev.	CT 211	12	12
Sand equivalent ^{a, b} (min.)		45	40
Fine aggregate angularity (% min.) ^{a, c}	CT 217	47	47
Fine aggregate angularity (% min.) ^{a, c}	CT 234	45	45
Flat and elongated particles (% max. by weight @ 5:1.) ^a	CT 235	10	10

Note:

^a Combine aggregate in the JMF proportions.

^b Reported value must be the average of 3 tests from a single sample.

^c The Engineer waives this specification if HMA contains less than 10 percent of nonmanufactured sand by weight of total aggregate. Manufactured sand is fine aggregate produced by crushing rock or gravel.

39-2.01(1a.5) Reclaimed Asphalt Pavement

The use of reclaimed asphalt pavement (RAP) in Type A HMA production may be substituted in a quantity up to 15 percent of the aggregate blend in the base course (bottom layer) only. RAP will not be allowed in the surface course.

39-2.01(1b) Hot Mix Asphalt Mix Design

The HMA mix design shall conform to the provisions of this Section. The mix design process shall consist of performing California Test 367 and laboratory procedures in combinations of aggregate gradations and asphalt binder contents to determine the optimum binder content (OBC) and HMA mixture qualities. The results shall become the proposed job mix formula (JMF).

The Contractor shall submit records of aggregate quality and mix design data. Test data shall be within one year from the last test performed.

The Contractor shall submit the HMA mix design using the "COUNTY OF RIVERSIDE TRANSPORTATION DEPARTMENT, CONTRACTOR JOB MIX FORMULA PROPOSAL" form to present the JMF. Formats other than the referenced form will not be accepted. See Appendices for the JMF form.

The final JMF shall be signed and stamped by a Civil Engineer registered in the State of California.

If any adjustment is made to the final JMF, a new mix design will be performed and a new JMF will be submitted.

The HMA mix design shall comply with the following requirements:

Mix Design Requirements

Quality characteristic	Test method	HMA Type	
		HMA-A	RHMA-G
Air void content (%)	CT 367	4.0 5.0 for 1-inch aggregate	--
Voids in mineral aggregate (% min.) No. 4 grading 3/8" grading 1/2" grading 3/4" grading 1" grading with NMAS = 1" with NMAS = 3/4"	CT 367	17.0 15.0 14.0 13.0 13.0 14.0	-- 18.0–23.0 ^a 18.0–23.0 ^a -- --
Voids filled with asphalt (%) No. 4 grading 3/8" grading 1/2" grading 3/4" grading 1" grading	CT 367	76.0–80.0 73.0–76.0 65.0–75.0 65.0–75.0 60.0–70.0	Note c
Dust proportion No. 4 and 3/8" gradings 1/2" and 3/4" gradings 1" grading	CT 367	0.9–2.0 0.6–1.3 0.6–1.2	Note c
Stabilometer value (min.) ^b No. 4 and 3/8" gradings 1/2" and 3/4" gradings 1" grading	CT 366	30 37 37 ^d (Modified) 35 ^e	-- 23 --

^a Voids in mineral aggregate for RHMA-G must be within this range.

^b California Test 304, Part 2.13.

^c Report this value in the JMF submittal.

^d Comply with California Test 366: 150 tamps at 500 psi tamping pressure and 230 °F compaction temperature; cool specimens to 140 °F; apply 12,600 lb leveling load; and perform stabilometer test at 140 °F.

^e Modify California Test 366: 150 tamps at 500 psi tamping pressure and 230 °F compaction temperature; cool specimens to 140 °F; apply additional 500 tamps at 500 psi; apply 12,600 lb leveling load; and perform stabilometer test at 140 °F.

39-2.01(1c) Certifications

Laboratories testing aggregate and HMA qualities used to prepare the mix design and JMF shall be qualified under the State of California Department of Transportation's Independent Assurance Program.

Before production of HMA, the HMA plant must have a current qualification under the State of California Department of Transportation's Materials Plant Quality Program.

39-2.01(1d) Construction

Construction of HMA shall be in conformance with the provisions of Section 39-2.01C, "Construction" of the Standard Specifications and these Special Provisions. Construction of RHMA shall be in conformance with the provisions of Section 39-2.03C, "Construction" of the Standard Specifications and these Special Provisions.

39-2.01(1d.1) Lift Thickness

Type A HMA shall comply with the aggregate gradation requirements and shall be spread and compacted in the number of layers of the thicknesses indicated in the following table:

Pavement Thickness Shown on Plans	No. of Layers ^a	Gradation
0.12 ft to less than 0.20 ft	1 ^b	1/2 inch
0.20 ft to less than 0.25 ft	1	3/4 inch
0.25 ft or greater	2 or more ^c	3/4 inch or 1 inch

^a Top layer shall not contain RAP in the HMA mix. Bottom and all other lower layers may contain up to 15 percent RAP in the HMA mix.

^b When placing in multiple lifts, each layer shall not be less than 0.15 foot.

^c One layer of 0.25 foot for the 3/4 inch or one layer of 0.35 foot for the 1 inch may be placed as approved by the Engineer.

39-2.01(1d.2) Sampling

The Contractor or the Contractor’s representative shall provide a sampling device in the asphalt feed line connecting the plant storage tanks to the asphalt weighing system or spray bar. The sampling device shall be accessible between 24 and 30 inches above the platform. The Contractor shall provide a receptacle for flushing the sampling device.

The sampling device shall include a valve:

1. With a diameter between 1/2 and 3/4 inches;
2. Manufactured in a manner that a one-quart sample may be taken slowly at any time during plant operations;
3. Maintained in good condition.

The Contractor shall replace failed valves.

In the presence of the Engineer, the Contractor shall take 2 one-quart samples per operating day. The Contractor shall provide round friction top containers with one-quart capacity for storing samples.

39-2.01(1d.3) Control of Materials

All proposed materials for use in HMA shall be furnished in conformance with the provisions of Section 6, “Control of Materials” of the Standard Specifications and this Section. All materials to be used in producing the hot mix asphalt shall be supplied from a single source for each material unless approved by the Engineer. Materials to be used in HMA will be subject to inspection and tests by the Engineer. The Contractor shall furnish without charge sample of materials as may be required.

The Contractor shall furnish the Engineer a list of the Contractor’s sources of materials and the locations at which those materials will be available for inspection. The Contractor shall assure that the Engineer has free access or entry at all times to the material or production of the material to be inspected, sampled, and tested. It is understood that the inspections and tests made at any point shall, in no way, be considered as a guaranty of acceptance of the material nor continued acceptance of the material presumed to be similar to that upon which inspections and tests have been made, and that inspection and testing performed by the Engineer shall not relieve the Contractor of responsibility for quality control.

All materials which the Engineer has determined defective or do not conform to the requirements of the plans and specifications will be rejected whether in place or not. Under the provisions of this Section, the Engineer will have authority to cause the removal and replacement of rejected material and to deduct the cost thereof from any moneys due or to become due the Contractor.

39-2.01(1d.4) Utility Covers

Except as otherwise provided herein, the Contractor shall adjust to finish grade any valve covers encountered within the project limits, as required, for those utility valves that are provided with slip cans and are adjustable without the replacement of part or the removal of concrete collars. In cases where the owning utility company insists upon upgrades in the standards, or when additional parts or the removal of concrete collars are required for the adjustment, said adjustment will be the responsibility of the owning utility company.

The Contractor shall lower manholes and valves when and as necessary for the protection of the traveling public during construction and shall coordinate all work on said facilities with the owning utility companies. Final adjustment to grade will be the responsibility of the owning utility company, except as provided herein.

39-2.01(1d.5) Placing HMA

Asphalt paving equipment shall be in conformance with the provisions of Section 39-2.01C(2), "Spreading and Compacting Equipment" of the Standard Specifications. Spreading and Compacting shall be in accordance with this Section and the provisions in Section 39-2.01C, "Construction" of the Standard Specifications. Construction of RHMA shall be in conformance with the provisions of Section 39-2.03C, "Construction" of the Standard Specifications.

When placing asphalt concrete to the lines and grades established by the Engineer, the automatic controls shall control the longitudinal grade and transverse slope of the screed. Grade and slope references shall be furnished, installed, and maintained by the Contractor. When directed, the Contractor shall use a ski device with a minimum length of 30 feet. The ski device shall be a rigid one piece unit and the entire length shall be utilized in activating the sensor.

When placing the initial mat of asphalt concrete on existing pavement, the end of the screed nearest the centerline shall be controlled by a sensor activated by a ski device not less than 30 feet. The end of the screed farthest from centerline shall be controlled by an automatic transverse slope device set to reproduce the cross slope designated by the Engineer, by a sensor activated by a similar ski device or as directed by the Engineer.

When paving contiguously with previously placed mats, the end of the screed adjacent to the previously placed mat shall be controlled by a sensor that responds to the grade of the previously placed mat and will reproduce the grade in the new mat within a 0.12 inch tolerance. The end of the screed farthest from the previously placed mat shall be controlled in the same way it was controlled when placing the initial mat.

Should the methods and equipment furnished by the Contractor fail to produce a layer of asphalt concrete conforming to the provisions, including straightedge tolerance, of Section 39-2.01C, "Construction" of the Standard Specifications or elsewhere in these Special Provisions, the paving operations shall be discontinued and the Contractor shall modify the equipment or methods, or furnish substitute equipment.

Should the automatic screed controls fail to operate properly during a day's work, the Contractor may manually control the spreading equipment for the remainder of that day. However, the equipment shall be corrected or replaced with alternative automatically controlled equipment conforming to the provisions in this section before starting another day's work.

39-2.01(1d.6) Contractor Quality Control

39-2.01(1d.6a) Quality Control Plan

The contractor shall submit a quality control plan with the proposed HMA type and mix design in accordance with Section 39-2.01A(3)(c), "Quality Control Plan" of the Standard Specifications.

39-2.01(1d.6b) HMA Production

The HMA production shall comply with the provisions of Section 39-2.01B(8) of the Standard Specification and the provisions of these Special Provisions. The RHMA production shall comply with the provisions of Section 39-2.03B(5) of the Standard Specification and the provisions of these Special Provisions.

39-2.01(1d.6c) Quality Control Testing

The Contractor shall perform quality control sampling and testing at the specified frequency for the quality characteristics shown in the following table:

Quality Control Testing Requirements

Quality Characteristic	Test Method	Minimum Sampling and Testing Frequency	HMA Type	
			HMA-A	RHMA-G
Aggregate gradation ^a	CT 202	1 per 750 tons and any remaining part	JMF ± Tolerance ^b	JMF ± Tolerance ^b
Sand equivalent (min) ^c	CT 217		47	47
Asphalt binder content (%)	CT 379 or CT 382		JMF ± 0.45	JMF ± 0.50
HMA moisture content (% max)	CT 226 or CT 370	1 per 1,500 tons but not less than 1 per paving day	1.0	1.0
Percent of maximum theoretical density (%) ^{d, e}	QC plan	2 per day's production (min.)	91–97	91-97
Stabilometer value (min) ^{c, f} No. 4 and 3/8" gradings 1/2" and 3/4" gradings 1" grading	CT 366	One per 3,000 tons or 2 per 5 business days, whichever is greater	30 37 37	23 --
Air void content (%) ^{c, g}	CT 367		4 ± 2 5 ± 2 for 1-inch aggregate	TV ± 2
Aggregate moisture content at continuous mixing plants and RAP moisture content at continuous mixing plants and batch mixing plants ^h	CT 226 or CT 370	2 per day during production	--	--
Percent of crushed particles coarse aggregate (% min) One fractured face Two fractured faces Fine aggregate (% min) (Passing no. 4 sieve and retained on no. 8 sieve.) One fractured face	CT 205	As designated in the QC plan. At least once per project.	90 75 (90 for 1-inch aggregate)	-- 90
Los Angeles Rattler (% max) Loss at 100 rev. Loss at 500 rev.	CT 211		12 45 (40 for 1-inch aggregate)	12 40
Flat and elongated particles (% max by weight @ 5:1)	CT 235		Report only (10 for 1-inch aggregate)	Report only
Fine aggregate angularity (% min)	CT 234		45	45
Voids filled with asphalt (%) ⁱ No. 4 grading 3/8" grading 1/2" grading 3/4" grading 1" grading	CT 367		76.0–80.0 73.0–76.0 65.0–75.0 65.0–75.0 60.0–70.0	Report only

Voids in mineral aggregate (% min) ⁱ No. 4 grading 3/8" grading 1/2" grading 3/4" grading 1" grading	CT 367		17.0 15.0 14.0 13.0 13.0	18.0-23.0 ^j 18.0-23.0 ^j
Dust proportion ^l No. 4 and 3/8" gradings 1/2" and 3/4" gradings 1" grading	CT 367		0.9-2.0 0.6-1.3 0.6-1.3	Report only
Smoothness	Special Provision 39-2.01 (1c.10)	--	12-foot straight-edge, must grind, and Pl ₀	12-foot straight-edge, must grind, and Pl ₀
Asphalt rubber binder viscosity @ 350°F, centipoises	Section 39-2.03B(3)	Section 39-2.03A (4)(C)(ii)	--	1,500-4,000
Asphalt modifier	Section 39-2.03B(3)	Section 39-2.03A (4)(C)(ii)	--	Section 39-2.03B(3)
CRM	Section 39-2.03B(3)	Section 39-2.03A (4)(C)(ii)	--	Section 39-2.03B(3)

^a Determine combined aggregate gradation containing RAP under California Test 367.

^b The tolerances must comply with the allowable tolerances in section 39-2.02B(4)(b) for HMA and section 39-2.03B(4)(b) for RHMA.

^c Report the average of 3 tests from a single split sample.

^d Required for HMA-A and RHMA-G if the specified paved thickness is at least 0.15 foot.

^e Determine maximum theoretical density (California Test 309) at the frequency specified for Test Maximum Density under California Test 375, Part 5.D.

^f California Test 304, Part 2.13.

^g Determine the bulk specific gravity of each lab-compacted briquette under California Test 308, Method A, and theoretical maximum specific gravity under California Test 309.

^h For adjusting the plant controller at the HMA plant.

ⁱ Report only if the adjustment for the asphalt binder content TV is less than or equal to ±0.3 percent from OBC value.

^j Voids in mineral aggregate for RHMA-G must be within this range.

For any single quality characteristic except smoothness, if 2 consecutive quality control test results do not comply with the action limits or specifications:

1. Stop production.
2. Notify the Engineer.
3. Take corrective action.
4. Demonstrate compliance with the specifications before resuming production and placement.

39-2.01(1d.6d) Density Cores

Unless otherwise directed by the Engineer, the Contractor shall take 4- or 6-inch diameter density cores from each 500 tons of HMA produced.

The location of the density cores shall be randomly selected by the Engineer and shall be performed in the Engineer's presence. Density holes shall be backfilled and compacted with material approved by the Engineer. Density cores shall be marked with the density core's location and layer number and shall be placed in a protective container. If a density core is damaged, it shall be replaced and re-cored within 1 foot longitudinally from the original density core.

39-2.01(1d.6e) Compaction

Contractor shall determine the in-place density and relative compaction of HMA pavement in accordance with the procedures of California Test 375. The Contractor shall use California Test 308, Method A, in determining in-place density of each density core instead of using the nuclear gauge in Part 4, "Determining In-Place Density by the Nuclear Density Device." The Contractor shall use California Test 309 to determine the maximum theoretical density instead of calculating test maximum density in Part 5, "Determining Test Maximum Density" and shall be at the frequency specified for Test Maximum Density under California Test 375, Part 5D. Relative compaction is required for HMA, and shall be reported at various pave thicknesses as listed in the following table:

HMA Relative Compaction Requirements

HMA Type	Minimum Pave Thickness (ft)	Relative Compaction (%)
HMA-A, (1/2-inch)	0.12	91-97
HMA-A, (3/4-inch)	0.20	91-97
HMA-A, (1-inch)	0.25	91-97

39-2.01(1d.7) Acceptance Criteria

The Engineer shall accept HMA based on compliance with the in place HMA quality requirements shown in the following table:

HMA Acceptance In Place

Quality characteristic	Test method	HMA Type				
		HMA-A	RHMA-G			
Aggregate gradation ^a	CT 202	JMF ± tolerance ^c	JMF ± tolerance ^c			
Sieve				3/4"	1/2"	3/8"
1/2"				X ^b		
3/8"					X	
No. 4						X
No. 8				X	X	X
No. 200	X	X	X			
Sand equivalent (min) ^d	CT 217	47	47			
Asphalt binder content (%)	CT 379 or 382	JMF ± 0.45	JMF ± 0.50			
HMA moisture content (% max)	CT 226 or 370	1.0	1.0			
Percent of maximum theoretical density (%) ^{e, f}	CT 375	91–97	91–97			
Stabilometer value (min) ^{d, g}	CT 366					
No. 4 and 3/8" gradings		30	--			
1/2" and 3/4" gradings		37	23			
1" grading		37	--			
Air void content (%) ^{d, h}	CT 367	4 ± 2	TV ± 2			
Percent of crushed particles	CT 205					
Coarse aggregate (% min)						
One fractured face		90	--			
Two fractured faces		75 (90 for 1-inch aggregate)	90			
Fine aggregate (% min)						
(Passing no. 4 sieve and retained on no. 8 sieve.)						
One fractured face	70 (90 for 1-inch aggregate)	70				
Los Angeles Rattler (% max)	CT 211					
Loss at 100 rev.		12	12			
Loss at 500 rev.		45 (40 for 1-inch aggregate)	40			
Fine aggregate angularity (% min)	CT 234	45	45			
Flat and elongated particles (% max by weight @ 5:1)	CT 235	Report only	Report only			
Voids filled with asphalt (%) ⁱ	CT 367					
No. 4 grading		76.0–80.0	Report only			
3/8" grading		73.0–76.0				
1/2" grading		65.0–75.0				
3/4" grading		65.0–75.0				
1" grading		60.0–70.0				
Voids in mineral aggregate (% min) ⁱ	CT 367					
No. 4 grading		17.0	--			
3/8" grading		15.0	--			
1/2" grading		14.0	18.0–23.0 ^j			
3/4" grading		13.0	18.0–23.0 ^j			
1" grading		13.0				
Dust proportion ⁱ	CT 367					
No. 4 and 3/8" gradings		0.9–2.0	Report only			
1/2" and 3/4" gradings		0.6–1.3				
1" grading		0.6–1.3				

Smoothness	Special Provision 39-2.01 (1c.10)	12-foot straight-edge, must grind, and Pl ₀	12-foot straight-edge, must grind, and Pl ₀
Asphalt binder	Various	Section 92	Section 92
Asphalt rubber binder	Various	--	Section 92-1.01D(2) and Section 39-2.03B(3)
Asphalt modifier	Various	--	Section 39-2.03B(3)
CRM	Various	--	Section 39-2.03B(3)

^a The Engineer determines combined aggregate gradations containing RAP under California Test 367.

^b "X" denotes the sieves the Engineer tests for the specified aggregate gradation.

^c The tolerances must comply with the allowable tolerances in section 39-2.02B(4)(b) for HMA Type A and section 39-2.03B(4)(b) for RHMA-G.

^d The Engineer reports the average of 3 tests from a single split sample.

^e The Engineer determines percent of maximum theoretical density if the specified paved thickness is at least 0.15 foot under California Test 375, except the Engineer uses:

1. California Test 308, Method A, to determine in-place density of each density core instead of using the nuclear gauge in Part 4, "Determining In-Place Density By The Nuclear Density Device."
2. California Test 309 to determine maximum theoretical density instead of calculating test maximum density in Part 5, "Determining Test Maximum Density."

^f The Engineer determines maximum theoretical density (California Test 309) at the frequency specified for Test Maximum Density under California Test 375, Part 5.D.

^g California Test 304, Part 2.13.

^h The Engineer determines the bulk specific gravity of each lab-compacted briquette under California Test 308, Method A, and theoretical maximum specific gravity under California Test 309.

ⁱ Report only if the adjustment for the asphalt binder content TV is less than or equal to ± 0.3 percent from the OBC value submitted on a *Contractor Hot Mix Asphalt Design Data* form.

^j Voids in mineral aggregate for RHMA-G must be within this range.

No single test result may represent more than 750 tons or 1 day's production, whichever is less.

For any single quality characteristic except smoothness, if 2 consecutive acceptance test results do not comply with the specifications:

1. Stop production.
2. Take corrective action.
3. Take samples and split each sample into 4 parts in the Engineer's presence. Test 1 part for compliance with the specifications and submit 3 parts to the Engineer. The Engineer tests 1 part for compliance with the specifications and reserves and stores 2 parts.
4. Demonstrate compliance with the specifications before resuming production and placement.

39-2.01(1d.8) HMA Acceptance and Payment Factor

The Engineer shall sample for acceptance testing and test for quality characteristics as specified in these Special Provisions. The Engineer shall determine the percent of maximum theoretical density from the average density of 3 density cores taken by the Contractor from every 500 tons of production or part thereof divided by the maximum theoretical density.

If the percent of maximum theoretical density does not comply with specifications, the Engineer shall determine a deduction using the following reduced payment factors:

Reduced Payment Factors for Percent of Maximum Theoretical Density

HMA-A percent of maximum theoretical density	Reduced payment factor	HMA-A percent of maximum theoretical density	Reduced payment factor
91.0	0.0000	97.0	0.0000
90.9	0.0125	97.1	0.0125
90.8	0.0250	97.2	0.0250
90.7	0.0375	97.3	0.0375
90.6	0.0500	97.4	0.0500
90.5	0.0625	97.5	0.0625
90.4	0.0750	97.6	0.0750
90.3	0.0875	97.7	0.0875
90.2	0.1000	97.8	0.1000
90.1	0.1125	97.9	0.1125
90.0	0.1250	98.0	0.1250
89.9	0.1375	98.1	0.1375
89.8	0.1500	98.2	0.1500
89.7	0.1625	98.3	0.1625
89.6	0.1750	98.4	0.1750
89.5	0.1875	98.5	0.1875
89.4	0.2000	98.6	0.2000
89.3	0.2125	98.7	0.2125
89.2	0.2250	98.8	0.2250
89.1	0.2375	98.9	0.2375
89.0	0.2500	99.0	0.2500
< 89.0	Remove and replace	> 99.0	Remove and replace

39-2.01(1d.9) Pavement Smoothness

The asphalt pavement smoothness shall conform to the provisions in Section 36-3, "Pavement Smoothness" of the Standard Specifications and these Special Provisions.

Pavement smoothness shall be tested using an inertial profiler except a 12-foot straightedge shall be used for the following conditions:

1. Pavement with a total thickness less than 0.24 foot
2. Pavement on horizontal curves with a centerline curve radius of less than 1,000 feet and pavement within the superelevation transition on those curves
3. Pavement placed in a single lift when required by the Special Provisions
4. Pavement with extensive grade or cross slope correction which does not receive advance leveling operations in conformance with the provisions in Section 39-2.01C(8), "Leveling" of the Standard Specifications
5. Pavement for ramps and connectors with steep grades and high rates of superelevation, as determined by the Engineer
6. Areas within 12.5 feet of manholes
7. Shoulders and miscellaneous areas

Where inertial profiler is required, the profiling operation shall conform to California Test 387 and the smoothness requirements in Section 36-3. Asphalt concrete pavement profiled shall conform to the following surface requirements:

1. Surface shall have no areas of localized roughness with an International Roughness Index (IRI) greater than 160 in/mi.
2. Surface shall comply with the Mean Roughness Index requirements shown in the following table for a 0.1 mile section:

HMA Thickness	Mean Roughness Index Requirement
>0.25 foot	60 in/mi or less
≤0.25 foot	75 in/mi or less

The pavement surfaces for smoothness shall be accepted based on compliance with the smoothness specifications for the type of pavement surface specified.

For areas that require pavement smoothness using a straightedge, the pavement surface shall not vary from the lower edge of the straightedge by more than:

1. 0.01 foot when the straightedge is laid parallel with the centerline
2. 0.02 foot when the straightedge is laid perpendicular to the centerline and extends from edge to edge of a traffic lane
3. 0.02 foot when the straightedge is laid within 24 feet of a pavement conform

For areas that require pavement smoothness using an inertial profiler, the International Roughness Index values for each 0.1-mile section shall be within 10 percent of the International Roughness Index specified value. The inertial profiler equipment and operator shall maintain current calibration and certification and shall be available when requested by the Engineer.

Areas of the asphalt concrete pavement surface that do not meet the specified surface tolerances shall be corrected by grinding. When an inertial profiler is used, a corrective grinding plan shall be submitted prior to performing corrective grinding for areas of localized roughness or areas exceeding the specified thresholds for the Mean Roughness Index. For pavement smoothness measured with a straightedge, a list of the areas requiring smoothness correction shall be submitted prior to performing corrective grinding. Areas which have been subjected to grinding and represent more than 25 percent of the total pavement surface profiled shall receive a slurry seal. Areas subjected to grinding but represent 25 percent or less of the total pavement surface profiled shall receive a fog seal. Ground areas which cannot be brought into specified tolerance by abrasive grinding shall be corrected by either (1) removal and replacement or (2) placing an overlay of asphalt concrete.

Ground areas shall be neat rectangular areas of uniform surface appearance and shall receive the respective seal coat prior to acceptance of the work. The limit of the respective seal (length and width) shall be directed by the Engineer.

39-2.01(1e) Payment

Full compensation for compliance with the requirements of this Section will be paid for on a force account basis, in accordance with Section 9-1.04, Force Account, of the Standard Specifications, and proposed markup percentages for the work performed.

AAAAAAAAAAAAAAAAAAAAAAAAAAAAAAAAAAAAAAAAAAAAAAAAAAAAAAAAAAAAAAAAAAAAAAAAAAAAAAAA

DIVISION V STRUCTURES

51 CONCRETE STRUCTURES

Replace Section 51-7 Minor Structures with the following:

51-7.01 GENERAL

51-7.01A General

Section 51-7 includes specifications for constructing minor structures.

Minor concrete structures shall conform to applicable provisions of Section 51, "Concrete Structures", Section 52, "Reinforcement", Section 75, "Miscellaneous Metals", and Section 90, "Concrete", of Standard Specifications, in accordance with applicable Standard Plans and details shown on the construction plans, these Special Provisions, and as directed by the Engineer.

Minor concrete structures for this project shall consist of:

- **Headwall for Double Circular Pipe per Caltrans Std. No. D89 modified**
- **Concrete Collars per RCFC&WCD STD M803**
- **4' Cut-Off Wall**

51-7.01B Materials

Concrete must comply with the specifications for minor concrete.

The cementitious material content of concrete must be at least 590 pounds per cubic yard.

All exposed metal shall be galvanized in conformance with Section 75-1.02B, Galvanizing, of the Standard Specifications.

All exposed concrete surfaces shall have anti-graffiti coating applied in conformance with Section 78-4.06, Anti-Graffiti Coating, of the Standard Specifications.

Non-shrink grout must be a dry, packaged type complying with ASTM C1107/C1107M.

Metal frames, covers, grates, and other miscellaneous iron and steel used with minor structures must comply with section 75-2.

51-7.01C Construction

You may construct minor structures using precast units or a combination of precast and cast-in-place structures as an alternative to cast-in-place construction, provided that the structure in place substantially complies with the specified CIP construction.

Remove exterior forms to at least 5 inches below the final ground surface. Exterior forms below this depth may remain if their total thickness is not more than 1 inch.

Cure concrete surfaces of minor structures using the water method, the forms-in-place method, or the curing compound method.

51-7.01D Payment

Full compensation to conform with the requirements of this section shall be paid on a force account basis, in accordance with Section 9-1.04, Force Account, of the Standard Specifications, and proposed markup percentages for the work performed; and shall include full compensation for all labor, materials, tools, and equipment and for doing all work involved in constructing the complete Minor Concrete Structures including the structures structural excavation and backfill, pervious backfill if required, removal of existing structures, as called out on the plans and applicable standard plans, furnishing and placing reinforcement steel bars, bond dowel rods at contact joints, construction joints, sawcutting, control joints, all miscellaneous metal parts,

DIVISION VIII MISCELLANEOUS CONSTRUCTION

72 SLOPE PROTECTION

Add to Section 72-1 GENERAL:

REPAIR EROSION DAMAGE - SLOPE REPAIR:

Slope repair/protection shall be placed or constructed in conformance with the provisions in Section 72, "Slope Protection," of the Standard Specifications, these Special Provisions, and as directed by the Engineer.

Slope repair must conform to the requirements in Section 19, "Earthwork," and Section 19-2.03G, "Slopes", of the Standard Specifications, these special provisions, and as directed by the Engineer.

Slope repair shall also consist of backfilling eroded areas with 2 sack slurry, grading or hand shaping slopes and compacting eroded areas at the locations as directed by the Engineer. Prior to slope repair work, clear the area in accordance with Section 17, "Clearing and Grubbing" of these special provisions. Embankment for slope repair shall be approved by Engineer. The slope repair areas, and adjacent areas, shall be graded to a uniform slope line.

Payment:

Full compensation for compliance with the requirements of this Section will be paid for on a force account basis, in accordance with Section 9-1.04, Force Account, of the Standard Specifications, and proposed markup percentages for the work performed.

72-2 ROCK SLOPE PROTECTION

Add to Section 72-2.01 General:

ROCK SLOPE PROTECTION (RSP) – RIP-RAP:

Rock slope protection shall be placed or constructed in conformance with the provisions in Section 72, "Slope Protection," and 72-2, Rock Slope Protection, of the Standard Specifications, the drainage construction details shown on the plans, these special provisions, and as directed by the Engineer.

Rock Slope Protection used in this project shall be:

- Class V, 1/4 Ton,

Rock Slope Protection shall be placed in conformance with Method "B".

Rock slope protection fabric shall be placed prior to placing rock slope protection. The fabric must be Class 8 RSP fabric. Rock slope protection fabric shall conform to the provisions in Section 72-1, "General," Section 96, "Geosynthetics," and Section 96-1.021, "Rock Slope Protection Fabric," of the standard specifications and shall be placed in conformance with the details shown on the plans and as directed by the Engineer.

Payment:

Full compensation to conform with the requirements of this section shall be paid on a force account basis, in accordance with Section 9-1.04, Force Account, of the Standard Specifications, and proposed markup percentages for the work performed; and shall include full compensation for furnishing all labor, equipment, materials and tools, and incidentals, and for doing all the work involved, complete in place, including rock slope protection fabric, any grading, excavation and backfill and no additional compensation will be allowed therefor.

DIVISION XI MATERIALS

96 GEOSYNTHETICS

Replace Section 96-1.02R Geomembrane, with:

96-1.02R Geomembrane

Geomembrane shall conform to the applicable provisions in section 96, Geosynthetics, of the Standard Specifications and these Special Provisions and as directed by the Engineer.

Geomembrane must be:

1. Polyethylene or polypropylene
2. Water resistant
3. Unreinforced or scrim reinforced

Geomembrane must comply with the requirements shown in the following tables:

Unreinforced Geomembrane

Quality characteristic	Test method	Requirement		
		Class A	Class B	Class C
Thickness, smooth (min, mil)	ASTM D5199	20	20	20
Thickness, textured (min, mil)	ASTM D5994			
Tensile break strength (min, lb/in)	ASTM D6693 Type IV	75	65	55
Puncture resistance (min, lb)	ASTM D4833	45	40	35
Tear resistance (min, lb)	ASTM D1004	20	15	10
Carbon black content (%)	ASTM D4218	2-3		

Scrim Reinforced Geomembrane

Quality characteristic	Test method	Requirement		
		Class A	Class B	Class C
Thickness, smooth (min, mil)	ASTM D5199	20	20	20
Thickness, textured (min, mil)	ASTM D5994			
Tensile break strength (min, lb)	ASTM D7004	250	200	150
Puncture resistance (min, lb)	ASTM D4833	45	40	35
Tear resistance (min, lb)	ASTM D5884	55	55	55
Ply adhesion (min, lb)	ASTM D6636	20	20	20
Carbon black content (%)	ASTM D4218	2-3		

Payment

Full compensation to conform with the requirements of this section shall be paid on a force account basis, in accordance with Section 9-1.04, Force Account, of the Standard Specifications, and proposed markup percentages for the work performed; and shall include full compensation for furnishing all labor, materials, tools, equipment, and incidentals and for doing all the work involved in placing geomembrane, complete in place, as shown on the exhibit, as specified in these Special Provisions and as directed by the Engineer and no additional compensation will be allowed.

Appendix A

AQMD Recommendations

Dust Abatement Attachments

Table of Contents

<u>Description</u>	<u>Page</u>
Signage Recommendation (AQMD document, modified)	1
Sample Dust Control Plan (AQMD sample)	5
Dust Control Plan Review Checklists (AQMD document)	6
Reasonably Available Control Measures (from Rule 403 Implementation Handbook)	10
Best Available Control Measures (from Rule 403 Implementation Handbook)	16
Best [Reasonably] Available Control Measures for High Winds Conditions (from Rule 403 Implementation Handbook)	22
Track Out Control Options (from Rule 403 Implementation Handbook)	26

AQMD SIGNAGE RECOMMENDATIONS**November, 2001**

Plan holder shall post signage at specified locations on the subject property in accordance with the standards specified below. The exception to the standards is that all letters shall be 4 inches high, with the names and telephone numbers of appropriate contacts and services in bold print, as indicated in the standards. These signs shall also include the SCAQMD toll free complaint line 1-800-CUT-SMOG (1-800-288-7664) and the telephone number for the Environmental Observer. These signs shall be posted within 50 feet of the curb on all four (4) corners of the subject property.

For each Dust Control Plan aggregating less than, or equal to, ten (10) acres:

1. The applicant shall install a sign on such property which is visible to the public that meets the following requirements:
 - (a) Such sign shall measure at least four (4) feet wide by four (4) feet high and conform to the specifications in 1 (a) below.

For each Dust Control Plan aggregating over ten (10) acres:

2. The applicant shall install a sign on such property which is visible to the public that meets the following requirements:
 - (a) Such sign shall measure at least eight (8) feet wide by four (4) feet high and conform to the specifications in 1 (b) below.

THE SIGN SHALL CONFORM TO THE FOLLOWING REQUIREMENTS:**1. The sign boards shall be constructed with materials capable of withstanding the environment in which they are placed.**

(a) For 4' x 4' signs, the District recommends the following:

- I. 3/4" A/C laminated plywood board
- II. Two 4" x 4" posts
- III. The posts should be attached to the edges of the plywood board with at least 2 carriage bolts on each post.
- IV. The front surface of the sign board should be painted in the contrasting color of a white background with black lettering.

(b) For 4' x 8' signs, the District recommends the following:

- I. 1" A/C laminated plywood board
- II. Two 5" x 6" posts
- III. The posts should be attached to the 4' edges of the plywood board with at least 2 carriage bolts on each post.
- IV. The front surface of the sign board should be painted in the contrasting color of a white background with black lettering.

2. The sign board shall be installed and maintained in a condition such that members of the public can easily view, access, and read the sign at all times until the expiration date of the Dust Control plan.

(a) For 4' x 4' signs, the District recommends the following:

- I. The lower edge of the sign board should be mounted at least 2' above the existing ground surface to facilitate ease of viewing.
- II. The posts should be set in a hole at least 3' deep with concrete footings to preclude downing by high winds.
- III. On the construction site, the sign should be positioned such that nothing obstructs the public's view from the primary street access point.
- IV. For construction projects that are developed in phases, the sign should be moved to the area that is under active construction.
- V. In situations where all phases of the construction project are completed on a property prior to expiration of the Dust Control Plan, a written request for cancellation of the Dust Control Plan must be submitted to the Engineer.

(b) For 4' x 8' signs, the District recommends the following:

- I. The lower edge of the sign board should be mounted at least 2' above the existing ground surface to facilitate ease of viewing.
- II. The posts should be set in a hole at least 4' deep with concrete footings to preclude downing by high winds.
- III. On the construction site, the sign should be positioned such that nothing obstructs the public's view from the primary street access point.
- IV. For construction projects that are developed in phases, the sign should be moved to the area that is under active construction.
- V. In situations where all phases of the construction project are completed on a property prior to expiration of the Dust Control Plan, a written request for cancellation of the Dust Control Plan must be submitted to the Engineer.

3. The sign board shall contain the following information:

- (a) Project Name
- (b) Name of Prime Contractor
- (c) Phone Number of Contractor's Employee Responsible for Dust Control Matters
- (d) County designated phone number (to be provided by the Engineer)
- (e) South Coast Air Quality Management District Phone Number

4. The sign board shall be designed to the following alpha and numeric text dimensions (sign boards written in longhand are unacceptable).

(a) For a permittee subject to the 4' x 4' sign requirement, the District provides the following example: (as modified by the County of Riverside for use on County Public Works projects)

1" UPPERCASE Letters →	PROJECT NAME:		3 ½" Title Case Bold Letters ←
1" UPPERCASE Letters →	CONTRACTOR		3 ½" Title Case Bold Letters ←
1" Title Case Letters →	Contractor's Dust Control Phone #		3" Bold Numbers ←
1" Title Case Letters →	County of Riverside Phone #		3" Bold Numbers ←
1" Title Case Letters →	Phone Number:	SCAQMD 1-800-CUT-SMOG	3 ½" Bold Numbers ←

"Title Case" means the first letter of a word is capitalized and subsequent letters are lower case.

(b) For a permittee subject to the 4' x 8' sign requirement, the District provides the following example: (as modified by the County of Riverside)

2" UPPERCASE Letters	PROJECT NAME:		4" Title Case Bold Letters
2" UPPERCASE Letters	CONTRACTOR		4" Title Case Bold Letters
2" Title Case Letters	Contractor's Dust Control Phone #		4" Bold Numbers
2" Title Case Letters	County of Riverside Phone #	951-	4" Bold Numbers
2" Title Case Letters	Phone Number:	SCAQMD 1-800-CUT-SMOG	4 1/2" Bold Numbers
2" Title Case Letters	COUNTY OF RIVERSIDE TRANSPORTATION DEPARTMENT		

Section 1

Simplified Sample Site Plan

Existing Residential

Distance and location of nearest:

Residence _____

Business _____

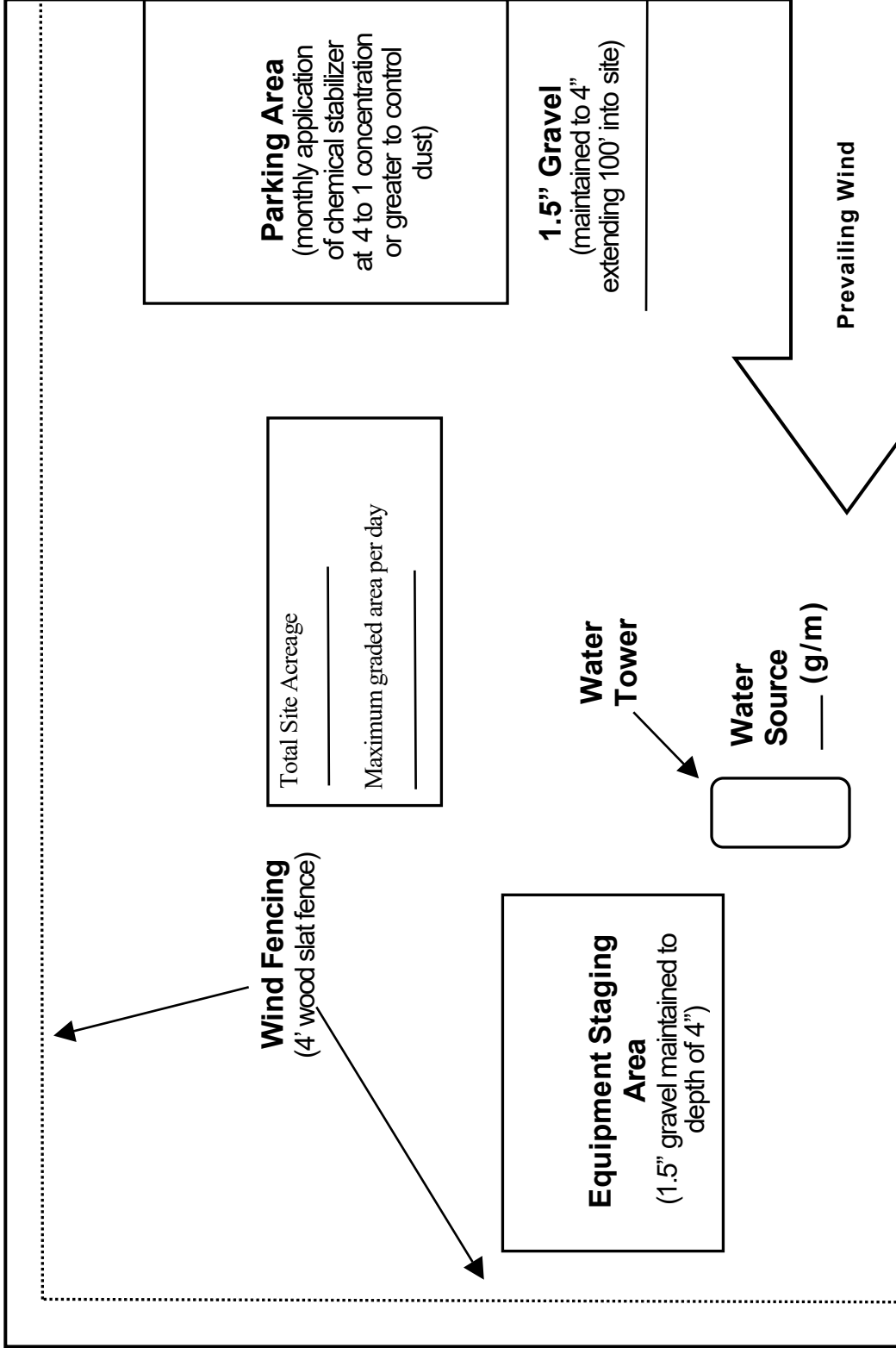
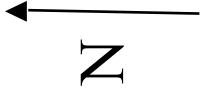

Existing Residential

Site Access

Parking Area
(monthly application of chemical stabilizer at 4 to 1 concentration or greater to control dust)

1.5" Gravel
(maintained to 4" extending 100' into site)

Prevailing Wind

Total Site Acreage _____
Maximum graded area per day _____

Water Tower

Water Source
_____ (g/m)

Vacant Land

Wind Fencing
(4' wood slat fence)

Equipment Staging Area
(1.5" gravel maintained to depth of 4")

Existing Residential

Remember...
DUST CONTROL IS REQUIRED 24 HOURS A DAY, 7 DAYS A WEEK,
REGARDLESS OF CONSTRUCTION STATUS

Plan Review Checklist

Clearing/Grubbing/Mass Grading Phase

- If feasible, use grading permit conditions to break the project into phases so that only a portion of the site is disturbed at any given time to ensure control of fugitive dust. This technique is critical for project sites with greater than 100 acres.

- Prior to initiating activity, pre-water site through use of portable irrigation lines. At least 72 hours of pre-watering is recommended for each area prior to initiating earth-movement. Require the Applicant to specify water source and available flow rate (g/m).

- Water applied continuously to all disturbed portions of the site by means of water truck/water pull as necessary to maintain sufficient visible moisture on the soil surface. For reference, one 2,000 gallon water truck can treat approximately 4 acres of active construction per hour. Also, for cut and fill activities, one 10,000 gallon water pull is estimated to be necessary for each 7,000 cubic yards of daily earth-movement. Multiple 4,000-gallon water trucks may be used in place of one 10,000-gallon water pull. Touch and visual contrast are reasonably good indicators of soil moisture. Surface areas that are dry to the touch and appear lighter-colored require the application of additional water to prevent visible or fugitive dust. Require the Applicant to specify the number of watering vehicles available for dust control during mass grading and during off-hours as well as availability of back-up water trucks if the site experiences dust control problems.

- Water towers are necessary for projects with more than 10 acres of active construction. Without a water tower, it can take up to 30 minutes to fill a 2,000 gallon water truck. Also, multiple water towers are necessary for projects that use water pulls as filling one 10,000 gallon water pull can drain a water tower which takes up to 40 minutes to refill.

- Wind fencing is necessary between the site and nearby residences or businesses. Off-site upwind fencing and on-site wind fencing for larger projects can also keep blowsand from being deposited onto the site or traveling through the site.

- A perimeter watering system consisting of portable irrigation equipment may be an effective mitigation system to protect surrounding residences and businesses. The portable watering system may be used in place of or in conjunction with watering trucks. The local jurisdiction may also be provided access to this equipment.

Remember...
DUST CONTROL IS REQUIRED 24 HOURS A DAY, 7 DAYS A WEEK,
REGARDLESS OF CONSTRUCTION STATUS

- Construction site accesses are to be improved with 1.5" gravel maintained to a depth of 4" , at least 20' wide, and extending 100 feet into the site. If the project site is not balanced, a wheel washing system and/or ribbed steel plates should be placed in the roadway before the vehicle enters the graveled area to clean the tires and prevent trackout.
- Equipment staging areas are to be treated with 1.5" gravel maintained to a depth of 4".
- Employee parking areas are to be covered with 1.5" gravel maintained to a depth of 4" or treated with chemical dust suppressants at a 4 to 1 ratio on at least a monthly basis to prevent fugitive dust.
- Chemical dust suppressants are to be mixed at a ratio of 20 to 1 and applied to all disturbed surfaces that are proposed to remain inactive for a period of at least 10 consecutive days. These products are effective in preventing and controlling dust. Recordkeeping is necessary to demonstrate compliance.
- All project sites greater than 100 acres shall monitor daily wind speeds and AQMD forecasted wind events (call 1.800.CUT.SMOG, press one for air quality information, and then press five for Coachella Valley wind forecasts). Operators shall maintain these records for review by any local code enforcement officer or AQMD inspector.
- An environmental observer whose primary duty is to oversee dust control at the site is to be used for construction projects greater than 100 acres and/or sites with more than 50 acres of active construction. The environmental observer is tasked with monitoring dust abatement measures and authorized to deploy additional water trucks and other dust control actions (i.e., wind fencing, street sweepers, chemical dust suppressants, etc.) as necessary to prevent or control fugitive dust.
- Other (specify): _____

Remember...
DUST CONTROL IS REQUIRED 24 HOURS A DAY, 7 DAYS A WEEK,
REGARDLESS OF CONSTRUCTION STATUS

**Plan Review Checklist
Finish Grading Phase**

Water applied continuously to all disturbed portions of the site by means of water truck/water pull as necessary to maintain sufficient visible moisture on the soil surface. For reference, one 2,000 gallon water truck can treat approximately 4 acres of active construction per hour. Also, for cut and fill activities, one 10,000 gallon water pull is estimated to be necessary for each 7,000 cubic yards of daily earth-movement. Multiple 4,000-gallon water trucks may be used in place of a 10,000-gallon water pull. Touch and visual contrast are reasonably good indicators of soil moisture. Surface areas that are dry to the touch and appear lighter-colored require the application of additional water to prevent visible or fugitive dust. Require the Applicant to specify the number of watering vehicles available for dust control during finish grading and during off-hours as well as availability of back-up water trucks if the site experiences dust control problems.

Water towers are necessary for projects with more than 10 acres of active construction. Without a water tower, it can take up to 30 minutes to fill a 2,000 gallon water truck. Also, multiple water towers are necessary for projects that use water pulls as filling one 10,000 gallon water pull can drain a water tower which takes up to 40 minutes to refill

Wind fencing is necessary between the site and nearby residences or businesses to reduce fugitive dust. Off-site upwind fencing and on-site wind fencing for larger projects can also keep blowsand from being deposited onto the site or traveling through a site.

Chemical dust suppressants are to be applied at a concentration of at least 10 to 1 to finish graded areas once final elevations have been reached. For areas that will remain inactive for longer periods, vegetation can be a cost-effective alternative to chemical stabilization. Wind fencing or other obstructions can keep the stabilized area free from future disturbances.

Construction site access(es) are to be improved with 1.5" gravel maintained to a depth of at least 4" ,with a minimum width of at least 20', extending 100 feet into the project site.

Equipment staging areas are to be treated with 1.5" gravel maintained to a depth of 4".

Internal roadway networks are to be treated with chemical dust suppressants at a minimum rate of at least 4 to 1 and retreated on a monthly basis once final roadway elevations have been reached.

Employee parking areas are to be treated with chemical dust suppressants at a mix ratio of at least 4 to 1 and retreated on at least a monthly basis or covered with 1.5" gravel maintained to a depth of 4" to prevent fugitive dust.

Other (specify): _____

**Remember...
DUST CONTROL IS REQUIRED 24 HOURS A DAY, 7 DAYS A WEEK,
REGARDLESS OF CONSTRUCTION STATUS**

**Plan Review Checklist
Construction Phase**

Water applied continuously to all disturbed portions of the site by means of water truck/water pull as necessary to maintain sufficient visible moisture on the soil surface. For reference, one 2,000 gallon water truck can treat approximately 4 acres of active construction per hour. Touch and visual contrast are reasonably good indicators of soil moisture. Surface areas that are dry to the touch and appear lighter-colored require the application of additional water to prevent visible or fugitive dust. Require the Applicant to specify the number of watering vehicles available for dust control during the construction phase and during off-hours as well as availability of back-up water trucks if the site experiences dust control problems.

Wind fencing is necessary between the site and nearby residences or businesses. Off-site upwind fencing and on-site wind fencing for larger projects can also keep blowsand from being deposited onto the site or traveling through the site. Block walls, if part of the final project, can replace wind fencing during the construction phase.

Chemical dust suppressants are to be applied at a concentration of at least 20 to 1 to finish graded areas once final elevations have been reached. For areas that will remain inactive for longer periods, vegetation can be a cost-effective alternative to chemical stabilization. Wind fencing or other obstructions can keep the stabilized area free from future disturbances.

Construction site accesses are to be improved with 1.5" gravel, maintained to a depth of 4", with a width of at least 20', extending 100' into the project site. Paving internal roadways can substitute for gravel.

Internal roadway networks are to be paved as early as feasible in the construction phase. Street sweeping of internal and/or external access roads will likely be required to control entrained road dust.

Employee parking areas are to be treated with chemical dust suppressants at a mix ratio of no less than 4 to 1 and retreated on a monthly basis, or more frequently if fugitive dust is observed. If internal roadway is complete, employees are to be instructed to park on paved roads.

Other (specify): _____

**Remember...
DUST CONTROL IS REQUIRED 24 HOURS A DAY, 7 DAYS A WEEK,
REGARDLESS OF CONSTRUCTION STATUS**

RULE 403 IMPLEMENTATION HANDBOOK

REASONABLY AVAILABLE CONTROL MEASURES

Paragraph (d)(3) of Rule 403 allows activities outside the South Coast Air Basin (see Figure 2-1) to implement reasonably available control measures in lieu of best available control measures. Additionally, as specified by subparagraph (f)(3)(D) or Rule 403, any person seeking approval of a fugitive dust emissions control plan for projects outside the South Coast Air Basin must demonstrate to the satisfaction of the District that the given activity is employing all reasonably available fugitive dust control measures.

The District has prepared the attached listing of reasonably available fugitive dust control measures for a variety of source categories. This list is based on the U.S. Environmental Protection Agency's reference document entitled, "Control of Open Fugitive Dust Sources," Midwest Research Institute, September 1988.

The District encourages the use of those dust control measures that minimize the use of potable water. When water is needed, reclaimed water should be utilized to the greatest extent feasible.

REASONABLY AVAILABLE CONTROL MEASURES

The left column contains a listing of the sources of fugitive dust which are intended for emission control under District Rule 403 and a listing of control measures and high-wind measures. The right column contains a description of the reasonably available fugitive dust control measures for each of the sources.

Source: (1) Land Clearing/Earth-Moving

CONTROL MEASURES

(A) Watering

DESCRIPTION

- (1) Application of water by means of trucks, hoses and/or sprinklers prior to conducting any land clearing. This will increase the moisture content of the soils; thereby increasing its stability.
 - (2) Pre-application of water to depths of proposed cuts.
 - (3) Once the land clearing/earth moving activities are complete, a second application of water can generate a thin crust that stabilizes the disturbed surface area provided that it is not disturbed. (Security fencing can be used to prevent unwanted future disturbances of sites where a surface crust has been created).
- (B) Chemical stabilizers
- (1) Only effective in areas which are not subject to daily disturbances.
 - (2) Vendors can supply information on product application and required concentrations to meet the specifications established by the Rule.
- (C) Wind fencing
- (1) Three- to five-foot barriers with 50% or less porosity located adjacent to roadways or urban areas can be effective in reducing the amount of windblown material leaving a site.
 - (2) Would likely be used in conjunction with other measures (e.g., watering, chemical stabilization, etc.) to ensure that visible emissions do not cross a property line.
- (D) Cover haul vehicles
- (1) Entire surface area of hauled earth should be covered once vehicle is full.
- (E) Bedliners in haul vehicles
- (1) When feasible, use in bottom-dumping haul vehicles.

HIGH WIND MEASURE

- (a) Cease all active operations; or
- (b) Apply water within 15 minutes to any soil surface which is being moved or otherwise disturbed.

Source: (2) Unpaved Roads**CONTROL MEASURES**

- (F) Paving
- (G) Chemical stabilization
- (H) Watering
- (I) Reduce speed limits
- (J) Reduce vehicular trips
- (K) Gravel
- DESCRIPTION**
- (1) Requires street sweeping/cleaning if subject to material accumulation.
- (1) Vendors can supply information as to application methods and concentrations to meet the specifications established by the Rule
- (2) Not recommended for high volume or heavy equipment traffic use.
- (1) In sufficient quantities to keep surface moist.
- (2) Required application frequency will vary according to soil type, weather conditions, and vehicular use.
- (1) 15 mile per hour maximum. May need to be used in conjunction with watering or chemical stabilization to prevent visible emissions from crossing the property line.
- (1) Access restriction or redirecting traffic to reduce vehicle trips by a minimum of 60 percent.
- (1) Gravel maintained to a depth of four inches can be an effective measure.
- (2) Should only be used in areas where paving, chemical stabilization or frequent watering is not feasible.

HIGH WIND MEASURE

- (c) Apply a chemical stabilizer (to meet the specifications established by the Rule) prior to wind events; or
- (d) Apply water once each hour; or
- (e) Stop all vehicular traffic.

January 1999

Source: (3) Storage Piles

CONTROL MEASURES

DESCRIPTION

- (L) Wind sheltering
 - (1) Enclose in silos.
 - (2) Install three-sided barriers equal to height of material, with no more than 50 percent porosity.
- (M) Watering
 - (1) Application methods include: spray bars, hoses and water trucks.
 - (2) Frequency of application will vary on site-specific conditions.
- (N) Chemical stabilizers
 - (1) Best for use on storage piles subject to infrequent disturbances.
- (O) Altering load-in/load-out procedures
 - (1) Confine load-in/load-out procedures to leeward (downwind) side of the material.
 - (2) May need to be used in conjunction with wind sheltering to prevent visible emissions from crossing the property line.
- (P) Coverings
 - (1) Tarps, plastic, or other material can be used as a temporary covering.
 - (2) When used, these should be anchored to prevent wind from removing coverings.

HIGH WIND MEASURE

- (f) Apply chemical stabilizers (to meet the specifications established by the Rule) prior to wind events; or
- (g) Apply water once per hour; or
- (h) Install temporary covers.

Source: (4) Paved Road Track-Out

CONTROL MEASURES

(Q) Chemical stabilization

DESCRIPTION

- (1) Most effective when used on areas where active operations have ceased.
- (2) Vendors can supply information on methods for application and required concentrations.

(R) Sweep/clean roadways

(1) Either sweeping or water flushing may be used.

(S) Cover haul vehicles

(1) Entire surface area should be covered once vehicle is full.

(T) Bedliners in haul vehicles

(1) When feasible, use in bottom dumping vehicles.

(U) Site access improvement

- (1) Pave internal roadway system.
- (2) Most important segment, last 100 yards from the connection with paved public roads

HIGH WIND MEASURE

(i) Cover all haul vehicles; and

(j) Clean streets with water flushing, unless prohibited by the Regional Water Quality Control Board.

Source: (5) Disturbed Surface Areas/Inactive Construction Sites

CONTROL MEASURES

DESCRIPTION

- (V) Chemical stabilization
 - (1) Most effective when used on areas where active operations have ceased.
 - (2) Vendors can supply information on method for application and required concentrations.
- (X) Watering
 - (1) Requires frequent applications unless a surface crust can be developed.
- (Y) Wind fencing
 - (1) Three- to five-foot barriers with 50% or less porosity adjacent to roadways or urban areas can be effective in reducing the amount of wind blown material leaving a site.
- (Z) Vegetation
 - (1) Establish as quickly as possible when active operations have ceased.
 - (2) Use of drought tolerant, native vegetation is encouraged.

HIGH WIND MEASURES

- (k) Apply chemical stabilizers (to meet the specifications established by the Rule); or
- (l) Apply water to all disturbed surface areas 3 times per day.

RULE 403 IMPLEMENTATION HANDBOOK

BEST AVAILABLE CONTROL MEASURES

Rule 403, paragraph (d)(2) requires active operations [defined in Rule 403, paragraph (c)(1)] within the South Coast Air Basin (see Figure 2-1) to implement at least one best available control measure for each fugitive dust source type on site. Additionally, as specified by subparagraph (f)(3)(D) of Rule 403, any person seeking approval of fugitive dust emissions control plan for projects within the South Coast Air Basin must demonstrate to the satisfaction of the AQMD that the given activity is employing all best available fugitive dust control measures.

The AQMD has prepared the attached listing of best available fugitive dust control measures for a variety of source categories. This list is based on the U.S. Environmental Protection Agency's reference document entitled, "Fugitive Dust Background Document and Technical Information Document for Best Available Control Measures," Office of Air and Radiation, September 1992.

The AQMD encourages the use of those dust control measures that minimize the use of potable water. When water is needed, reclaimed water should be utilized to the greatest extent feasible.

BEST AVAILABLE CONTROL MEASURES

The left column contains a listing of the sources of fugitive dust which are intended for emission control under District Rule 403 and a listing of control measures and high-wind measures. The right column contains a description of the best available fugitive dust control measures for each of the sources.

Source: (1) Land Clearing/Earth-Moving

CONTROL MEASURES

DESCRIPTION

- | | |
|--------------------------------|---------------------------------------------------------------------------------------------------------------------------------------------------------------------------------------------------------------------------------------------------------------------------------------------------------------------------------------------------------------------------------------------------------------------------------------------------|
| (A) Watering (pre-grading) | (1) Application of water by means of trucks, hoses and/or sprinklers prior to conducting any land clearing. This will increase the moisture content of the soils; thereby increasing its stability. |
| (A-1) Watering (post-grading) | (2) Pre-application of water to depths of proposed cuts. |
| (A-2) Pre-grading planning | (1) In active earth-moving areas water should be applied at sufficient frequency and quantity to prevent visible emissions from extending more than 100 feet from the point of origin.
(1) Grade each phase separately, timed to coincide with construction phase; or
(2) Grade entire project, but apply chemical stabilizers or ground cover to graded areas where construction phase begins more than 60 days after grading phased ends. |
| (B) Chemical stabilizers | (1) Only effective in areas which are not subject to daily disturbances.
(2) Vendors can supply information on product application and required concentrations to meet the specifications established by the Rule. |
| (C) Wind fencing | (1) Three- to five-foot barriers with 50% or less porosity located adjacent to roadways or urban areas can be effective in reducing the amount of windblown material leaving a site. Must be implemented in conjunction with either measure (A-1) or (B). |
| (D) Cover haul vehicles | (1) Entire surface area of hauled earth should be covered once vehicle is full. |
| (E) Bedliners in haul vehicles | (1) When feasible, use in bottom-dumping haul vehicles. |

HIGH WIND MEASURE

- (a) Cease all active operations; or
- (b) Apply water within 15 minutes to any soil surface which is being moved or otherwise disturbed.

RULE 403 IMPLEMENTATION HANDBOOK

Source: (2) Unpaved Roads

CONTROL MEASURES

DESCRIPTION

- | | |
|----------------------------|-----------------------------------------------------------------------------------------------------------------------------------------------------------------------------------------------------------|
| (F) Paving | (1) Requires street sweeping/cleaning if subject to material accumulation. |
| (G) Chemical stabilization | (1) Vendors can supply information as to application methods and concentrations to meet the specifications established by the Rule
(2) Not recommended for high volume or heavy equipment traffic use. |
| (H) Watering | (1) In sufficient quantities to keep surface moist.
(2) Required application frequency will vary according to soil type, weather conditions, and vehicular use. |
| (I) Reduce speed limits | (1) 15 mile per hour maximum. May need to be used in conjunction with watering or chemical stabilization to prevent visible emissions from crossing the property line. |
| (J) Reduce vehicular trips | (1) Access restriction or redirecting traffic to reduce vehicle trips by a minimum of 60 percent. |
| (K) Gravel | (1) Gravel maintained to a depth of four inches can be an effective measure.
(2) Should only be used in areas where paving, chemical stabilization or frequent watering is not feasible. |

HIGH WIND MEASURE

- (a) Apply a chemical stabilizer (to meet the specifications established by the Rule) prior to wind events; or
- (b) Apply water once each hour; or
- (c) Stop all vehicular traffic.

RULE 403 IMPLEMENTATION HANDBOOK

Source: (3) Storage Piles

CONTROL MEASURES

DESCRIPTION

- (L) Wind sheltering
- (1) Enclose in silos.
 - (2) Install three-sided barriers equal to height of material, with no more than 50 percent porosity.
- (M) Watering
- (1) Application methods include: spray bars, hoses and water trucks.
 - (2) Frequency of application will vary on site-specific conditions.
- (N) Chemical stabilizers
- (1) Best for use on storage piles subject to infrequent disturbances.
- (O) Altering load-in/load-out procedures
- (1) Confine load-in/load-out procedures to leeward (downwind) side of the material.
Must be used in conjunction with either measure (L), (M), (N), or (P).
- (P) Coverings
- (1) Tarps, plastic, or other material can be used as a temporary covering.
 - (2) When used, these should be anchored to prevent wind from removing coverings.

HIGH WIND MEASURE

- (a) Apply chemical stabilizers (to meet the specifications established by the Rule) prior to wind events; or
- (b) Apply water once per hour; or
- (c) Install temporary covers.

RULE 403 IMPLEMENTATION HANDBOOK

Source: (5) Disturbed Surface Areas/Inactive Construction Sites**CONTROL MEASURES****DESCRIPTION**

- (Q) Chemical stabilization
- (1) Most effective when used on areas where active operations have ceased.
- (2) Vendors can supply information on method for application and required concentrations.
- (R) Watering
- (1) Requires frequent applications unless a surface crust can be developed.
- (S) Wind fencing
- (1) Three- to five-foot barriers with 50% or less porosity adjacent to roadways or urban areas can be effective in reducing the amount of wind blown material leaving a site. Must be used in conjunction with either measure (Q), (R), or (T).
- (T) Vegetation
- (1) Establish as quickly as possible when active operations have ceased.*

HIGH WIND MEASURES

- (a) Apply chemical stabilizers (to meet the specifications established by the Rule); or
- (b) Apply water to all disturbed surface areas 3 times per day.

* Use of drought tolerant, native vegetation is encouraged.

TABLE 1

BEST [REASONABLY]* AVAILABLE CONTROL MEASURES FOR HIGH WIND CONDITIONS

<u>FUGITIVE DUST SOURCE CATEGORY</u>	<u>CONTROL MEASURES</u>
Earth-moving	(1A) Cease all active operations; OR (2A) Apply water to soil not more than 15 minutes prior to moving such soil.
Disturbed surface areas	(0B) On the last day of active operations prior to a weekend, holiday, or any other period when active operations will not occur for not more than four consecutive days: apply water with a mixture of chemical stabilizer diluted to not less than 1/20 of the concentration required to maintain a stabilized surface for a period of six months; OR (1B) Apply chemical stabilizers prior to wind event; OR (2B) Apply water to all unstabilized disturbed areas 3 times per day. If there is any evidence of wind driven fugitive dust, watering frequency is increased to a minimum of four times per day; OR (3B) Take the actions specified in Table 2, Item (3c); OR (4B) Utilize any combination of control actions (1B), (2B), and (3B) such that, in total, these actions apply to all disturbed surface areas.
Unpaved roads	(1C) Apply chemical stabilizers prior to wind event; OR (2C) Apply water twice [once] per hour during active operation; OR (3C) Stop all vehicular traffic.
Open storage piles	(1D) Apply water twice per hour; OR (2D) Install temporary coverings.
Paved road track-out	(1E) Cover all haul vehicles; OR (2E) Comply with the vehicle freeboard requirements of Section 23114 of the California Vehicle Code for both public and private roads.
All Categories	(1F) Any other control measures approved by the Executive Officer and the U.S. EPA as equivalent to the methods specified in Table 1 may be used.

* Measures in [brackets] are reasonably available control measures and only apply to sources not within the South Coast Air Basin.

TABLE 2

DUST CONTROL ACTIONS FOR EXEMPTION FROM PARAGRAPH (d)(4)*

<u>FUGITIVE DUST SOURCE CATEGORY</u>	<u>CONTROL ACTIONS</u>
Earth-moving (except construction cutting and filling areas, and mining operations)	<p>(1a) Maintain soil moisture content at a minimum of 12 percent, as determined by ASTM method D-2216, or other equivalent method approved by the Executive Officer, the California Air Resources Board, and the U.S. EPA. Two soil moisture evaluations must be conducted during the first three hours of active operations during a calendar day, and two such evaluations each subsequent four-hour period of active operations; OR</p> <p>(1a-1) For any earth-moving which is more than 100 feet from all property lines, conduct watering as necessary to prevent visible dust emissions from exceeding 100 feet in length in any direction.</p>
Earth-moving: Construction fill areas:	<p>(1b) Maintain soil moisture content at a minimum of 12 percent, as determined by ASTM method D-2216, or other equivalent method approved by the Executive Officer, the California Air Resources Board, and the U.S. EPA. For areas which have an optimum moisture content for compaction of less than 12 percent, as determined by ASTM Method 1557 or other equivalent method approved by the Executive Officer and the California Air Resources Board and the U.S. EPA, complete the compaction process as expeditiously as possible after achieving at least 70 percent of the optimum soil moisture content. Two soil moisture evaluations must be conducted during the first three hours of active operations during a calendar day, and two such evaluations during each subsequent four-hour period of active operations.</p>

* Measures in [brackets] are reasonably available control measures and only apply to sources not within the South Coast Air Basin.

TABLE 2 (Continued)*

<u>FUGITIVE DUST SOURCE CATEGORY</u>	<u>CONTROL ACTIONS</u>
Earth-moving: Construction cut areas and mining operations:	(1c) Conduct watering as necessary to prevent visible emissions from extending more than 100 feet beyond the active cut or mining area unless the area is inaccessible to watering vehicles due to slope conditions or other safety factors.
Disturbed surface areas (except completed grading areas)	(2a/b) Apply dust suppression in sufficient quantity and frequency to maintain a stabilized surface. Any areas which cannot be stabilized, as evidenced by wind driven fugitive dust must have an application of water at least twice per day to at least 80 [70] percent of the unstabilized area.
Disturbed surface areas: Completed grading areas	(2c) Apply chemical stabilizers within five working days of grading completion; OR (2d) Take actions (3a) or (3c) specified for inactive disturbed surface areas.
Inactive disturbed surface areas	(3a) Apply water to at least 80 [70] percent of all inactive disturbed surface areas on a daily basis when there is evidence of wind driven fugitive dust, excluding any areas which are inaccessible to watering vehicles due to excessive slope or other safety conditions; OR (3b) Apply dust suppressants in sufficient quantity and frequency to maintain a stabilized surface; OR (3c) Establish a vegetative ground cover within, 21 [30] days after active operations have ceased. Ground cover must be of sufficient density to expose less than 30 percent of unstabilized ground within 90 days of planting, and at all times thereafter; OR (3d) Utilize any combination of control actions (3a), (3b), and (3c) such that, in total, these actions apply to all inactive disturbed surface areas.

* Measures in [brackets] are reasonably available control measures and only apply to sources not within the South Coast Air Basin.

TABLE 2 (Continued)*

<u>FUGITIVE DUST SOURCE CATEGORY</u>	<u>CONTROL ACTIONS</u>
Unpaved Roads	(4a) Water all roads used for any vehicular traffic at least once per every two hours of active operations [3 times per normal 8 hour work day]; OR (4b) Water all roads used for any vehicular traffic once daily and restrict vehicle speeds to 15 miles per hour; OR (4c) Apply a chemical stabilizer to all unpaved road surfaces in sufficient quantity and frequency to maintain a stabilized surface.
Open storage piles	(5a) Apply chemical stabilizers; OR (5b) Apply water to at least 80 [70] percent of the surface area of all open storage piles on a daily basis when there is evidence of wind driven fugitive dust; OR (5c) Install temporary coverings; OR (5d) Install a three-sided enclosure with walls with no more than 50 percent porosity which extend, at a minimum, to the top of the pile.
<u>All Categories</u>	(6a) Any other control measures approved by the Executive Officer and the U.S. EPA as equivalent to the methods specified in Table 2 may be used.

* Measures in [brackets] are reasonably available control measures and only apply to sources not within the South Coast Air Basin.

TABLE 3
TRACK-OUT CONTROL OPTIONS
PARAGRAPH (d)(5)(B)

CONTROL OPTIONS

(1)	Pave or apply chemical stabilization at sufficient concentration and frequency to maintain a stabilized surface starting from the point of intersection with the public paved surface, and extending for a centerline distance of at least 100 feet and a width of at least 20 feet.
(2)	Pave from the point of intersection with the public paved road surface, and extending for a centerline distance of at least 25 feet and a width of at least 20 feet, and install a track-out control device immediately adjacent to the paved surface such that exiting vehicles do not travel on any unpaved road surface after passing through the track-out control device.
(3)	Any other control measures approved by the Executive Officer and the U.S. EPA as equivalent to the methods specified in Table 3 may be used.

Appendix B

RCP and Headwall Sketch

NOTES

- ① CONTINUE / KEEP THE EXISTING SLOPE
 - ② SAWCUT EXISTING CONCRETE PIPE
 - ③ SAWCUT AND REMOVE HEADWALL PORTIONS INTERFERING WITH THE PROPOSED HEADWALL BASE SLAB
- THE CONTRACTOR SHALL VERIFY ALL CONTROLLING FIELD DIMENSIONS BEFORE ORDERING OR FABRICATING ANY MATERIAL

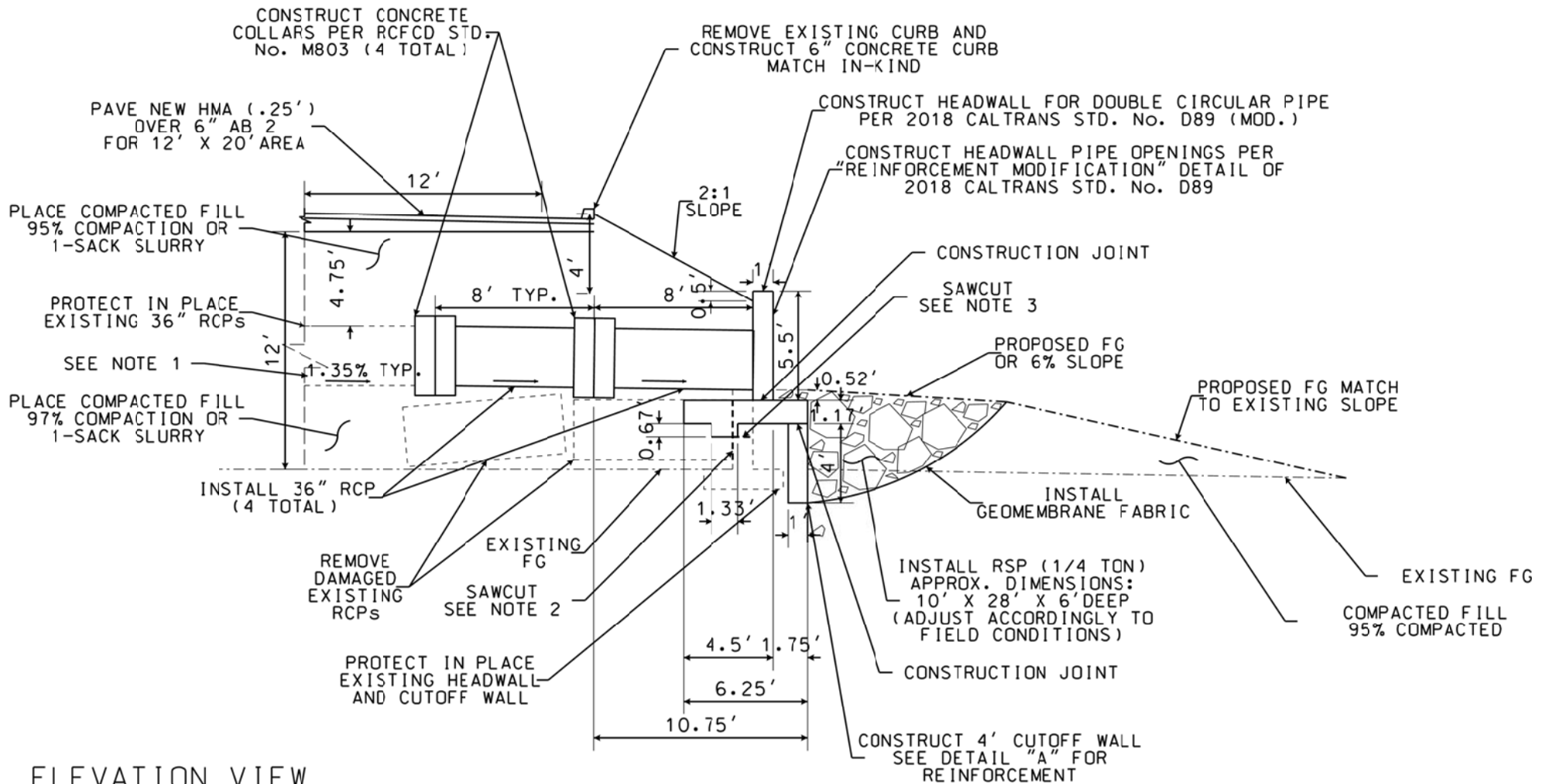

ELEVATION VIEW

NOTES

- ① DISTANCE TO BE FIELD VERIFIED
 - ② FOR ALL OTHER REINFORCEMENT DETAILS REFER TO 2018 CALTRANS STD. No. D89 "TYPICAL SECTION" DETAIL
- THE CONTRACTOR SHALL VERIFY ALL CONTROLLING FIELD DIMENSIONS BEFORE ORDERING OR FABRICATING ANY MATERIAL

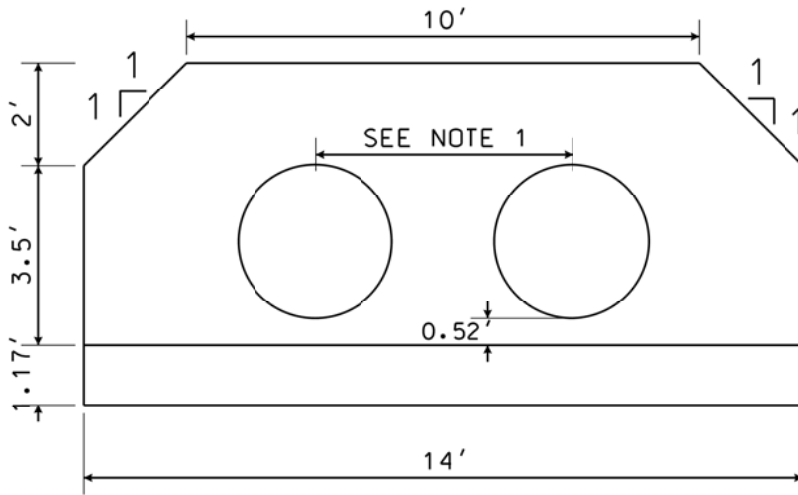

ELEVATION VIEW

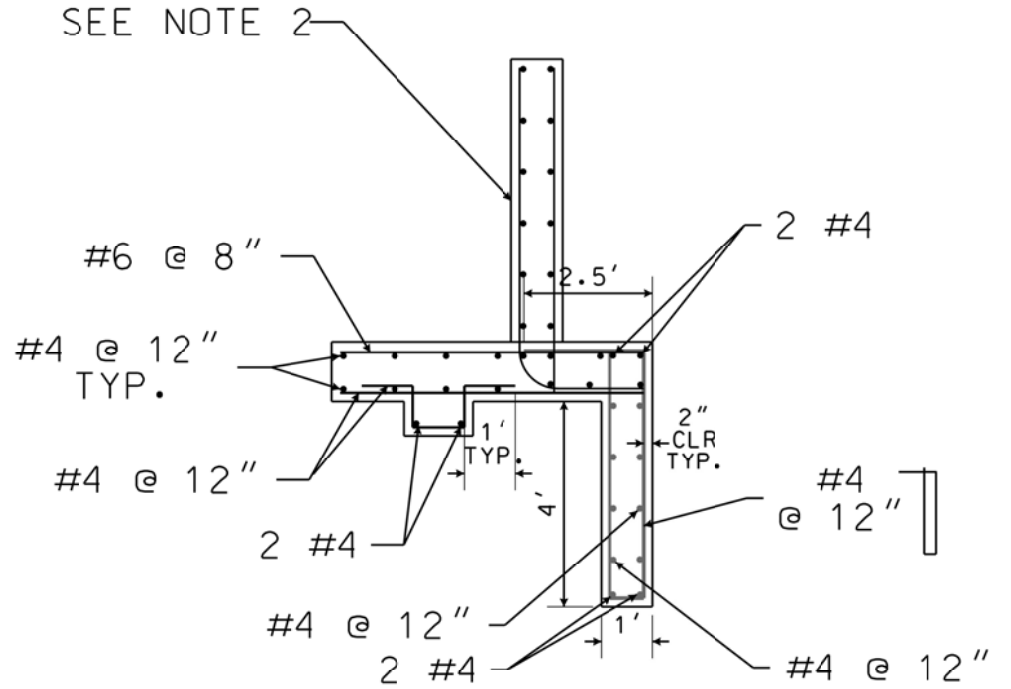

DETAIL "A"
FOOTING REINFORCEMENT

Schedule A – Budget Adjustment FY23/24

Increase in Appropriations:

10000-4200600000- 522310	Maintenance - Buildings & Improvements	\$340,000
--------------------------	----------------------------------------	-----------

Anticipated Use of Unassigned Fund Balance:

10000-4200600000-370100	Unassigned Fund Balance	\$340,000
-------------------------	-------------------------	-----------

Decrease Appropriations:

10000-1109000000-581000	Appropriation for Contingency	\$340,000
-------------------------	-------------------------------	-----------

Anticipated Increase of Unassigned Fund Balance:

10000-1109000000-370100	Unassigned Fund Balance	\$340,000
-------------------------	-------------------------	-----------