

**SUBMITTAL TO THE BOARD OF SUPERVISORS
COUNTY OF RIVERSIDE, STATE OF CALIFORNIA**



**ITEM: 3.74
(ID # 27664)**

MEETING DATE:
Tuesday, June 24, 2025

FROM : TLMA-TRANSPORTATION

SUBJECT: TRANSPORTATION AND LAND MANAGEMENT AGENCY/TRANSPORTATION:
Ratify and Approve Contract Change Order No. 1 – Between the County of Riverside and Hardy & Harper, Inc. for the Construction of the Indiana Avenue, Grant Street and Harlow Avenue Resurfacing Project; District 2. [\$263,437 Total Cost – Local Funds 100%]

RECOMMENDED MOTION: That the Board of Supervisors:

1. Ratify and Approve Contract Change Order No. 1 with Hardy & Harper, Inc. on the Indiana Avenue, Grant Street and Harlow Avenue Resurfacing Project, and authorize the Chair of the Board to execute the same; and
2. Authorize the Transportation Department to issue Contract Change Order No. 1 with Hardy & Harper, Inc. on the Indiana Avenue, Grant Street and Harlow Avenue Resurfacing Project.

ACTION:Policy

Dennis Acuna, Director of Transportation 5/26/2025

MINUTES OF THE BOARD OF SUPERVISORS

On motion of Supervisor Spiegel, seconded by Supervisor Medina and duly carried by unanimous vote, IT WAS ORDERED that the above matter is approved as recommended.

Ayes: Medina, Spiegel, Washington, Perez and Gutierrez
Nays: None
Absent: None
Date: June 24, 2025
xc: TLMA-Transp.

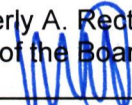
Kimberly A. Rector
Clerk of the Board
By: 
Deputy

**SUBMITTAL TO THE BOARD OF SUPERVISORS COUNTY OF RIVERSIDE,
STATE OF CALIFORNIA**

FINANCIAL DATA	Current Fiscal Year:	Next Fiscal Year:	Total Cost:	Ongoing Cost
COST	\$ 263,437	\$ 0	\$ 263,437	\$ 0
NET COUNTY COST	\$ 0	\$ 0	\$ 0	\$ 0
SOURCE OF FUNDS: Unincorporated Communities Initiative (UCI)(100%). There are no General Funds used in this project.			Budget Adjustment:	No
			For Fiscal Year:	24/25

C.E.O. RECOMMENDATION: Approve

BACKGROUND:

Summary

By Minute Order 3.46 of October 22, 2024, the Board of Supervisors entered into a contract with Hardy & Harper, Inc. to construct the Indiana Avenue, Grant Street and Harlow Avenue Resurfacing Project in the Community of Home Gardens of the County of Riverside.

The original authorized amount of the contract was \$3,185,000. The total amount of Contract Change Order No. 1 exceeds the cumulative change order amounts that can be authorized by the Director of Transportation. Therefore, this change order requires approval from the Board of Supervisors in accordance with Resolution No. 2019-035:

Details of the Contract Change Order is as follows:

- Contract Change Order No. 1 is \$263,437.08 (8.27% of the original contract amount)

Contract Change Order No. 1 became necessary due to the reconstruction of Klyne Street between Bobbitt Street and Bedford Canyon Road in the El Cerrito area. Klyne Street, work order number D5-0053, is in a transition to become a County maintained road and will be included under existing contract work order numbers C6-0080 for Indiana Avenue Resurfacing and D2-0022 for Grant Street and Harlow Avenue Resurfacing.

Project Nos. C6-0080, D2-0022, D5-0053

Impact on Residents and Businesses

The project will provide the public with a smooth paved roadway surface that will improve the safety and efficiency of vehicular traffic.

Additional Fiscal Information

Contract Change Order No. 1 brings the total current authorized contract change order amount to \$3,448,437.08, which is 8.27% over the originally authorized contract amount of \$3,185,000. The department received approximately \$960,000 in UCI funding for roads in El Cerrito through BOS item 3.8 on 06/27/23. A portion of these funds will be used for this change order.

SUBMITTAL TO THE BOARD OF SUPERVISORS COUNTY OF RIVERSIDE,
STATE OF CALIFORNIA

ATTACHMENTS:

Vicinity Map

CCO No. 1

Change Order Report

Klyne Street Plans



Jason Farin, Principal Policy Analyst

6/19/2025



Aaron Gettis, Chief of Deputy County Counsel

6/9/2025



**COUNTY OF RIVERSIDE
TRANSPORTATION DEPARTMENT**

SHEET 1 OF 2 SHEETS

Contract Change Order No. 1

CONTRACT: **Indiana Avenue Resurfacing
Grant Street and Harlow Avenue Resurfacing**

WORK ORDER NO. C6-0080, D2-0022
 CALTRANS EA NO. N/A
 LOCAL-FED AID NO. N/A
 STATE-FED AID NO. N/A

TO: HARDY & HARPER, INC. CONTRACTOR: YOU ARE HEREBY DIRECTED TO MAKE THE HEREIN DESCRIBED CHANGES FROM THE PLANS AND SPECIFICATIONS OR DO THE FOLLOWING DESCRIBED WORK NOT INCLUDED IN THE PLANS AND SPECIFICATIONS ON THIS CONTRACT.

Description of work to be done, estimate of quantities and prices to be paid. Segregated between additional work at contract price, agreed price and force account. Unless otherwise stated, rates for rental of equipment cover only such time as equipment is actually used and no allowance will be made for idle time.

Estimate of Extra Work at Agreed Unit Price:

As directed by the Engineer and in accordance with the attached plans, details, and applicable of the Special Provisions, compensate the Contractor for furnishing labor, equipment, material, and incidentals for the construction of the following work items at agreed unit price:

Item Description	Unit	Quantity	Unit Price	Amount
Mobilization	LS	1.00	\$19,900.00	\$19,900.00
Water Pollution Control Program (Amend.)	LS	1.00	\$ 2,780.00	\$ 2,780.00
Construct AC Dike (16" high) per plans	LS	1.00	\$28,196.50	\$28,196.50
Pulverize Existing Asphalt Pavement (Incl. Moisture/grade/compact)	SY	1,762.55	\$ 14.00	\$24,675.70
Hot Mix Asphalt	TN	439.00	\$ 173.00	\$75,947.00
Construct 6" & Type "D" HMA Dike	LF	250.00	\$ 22.00	\$ 5,500.00
Construct Header Cut	SY	152.00	\$ 37.00	\$ 5,624.00
Construct 4" Thick AC Driveway	SY	358.44	\$ 127.00	\$45,521.88
Construct Safety Edge (with Shoulder Backing)	LF	394.00	\$ 14.00	\$ 5,516.00
Remove and/or Trim Trees & Stumps	EA	1.00	\$ 3,500.00	\$ 3,500.00
Adjust Water Valve to grade	EA	3.00	\$ 500.00	\$ 1,500.00
Roadway Excavation	CY	232.00	\$ 193.00	\$44,776.00
Total =				\$263,437.08

There will be no adjustments in the Contract Unit Prices for the above items due to increases or decreases in quantity in excess of 25% of the Engineer's Estimate by reason of this Change Order.

Funded by: Work Order D5-0053 – Klyne Street Reconstruction

Estimated Cost: Decrease \$ Increase \$263,437.08

Participating: Yes: No: N/A:



COUNTY OF RIVERSIDE
TRANSPORTATION DEPARTMENT

SHEET 2 OF 2 SHEETS

Contract Change Order No. 1

CONTRACT: **Indiana Avenue Resurfacing
Grant Street and Harlow Avenue Resurfacing**

WORK ORDER NO.	<u>C6-0080, D2-0022</u>
CALTRANS EA NO.	<u>N/A</u>
LOCAL-FED AID NO.	<u>N/A</u>
STATE-FED AID NO.	<u>N/A</u>

This Change Order may be executed in any number of counterparts, each of which will be an original, but all of which together will constitute one instrument. Each party to this Change Order agrees to the use of electronic signatures, such as digital signatures that meet the requirements of the California Uniform Electronic Transactions Act ("CUETA") Cal. Civ. Code §§ 1633.1 to 1633.17), for executing this Change Order. The parties further agree that the electronic signatures of the parties included in this Change Order are intended to authenticate this writing and to have the same force and effect as manual signatures. Electronic signature means an electronic sound, symbol, or process attached to or logically associated with an electronic record and executed or adopted by a person with the intent to sign the electronic record pursuant to the CUETA as amended from time to time. The CUETA authorizes use of an electronic signature for transactions and contracts among parties in California, including a government agency. Digital signature means an electronic identifier, created by computer, intended by the party using it to have the same force and effect as the use of a manual signature, and shall be reasonably relied upon by the parties. For purposes of this section, a digital signature is a type of "electronic signature" as defined in subdivision (i) of Section 1633.2 of the Civil Code.

WE, the undersigned contractor, have given careful consideration to the change proposed and hereby agree that we will provide all equipment, furnish all materials, except as may otherwise be noted above, and perform all services necessary for the work above specified, and will accept as full payment therefor the prices shown above. By reason of this proposed change 0 days adjustment of time will be allowed.

NOTE: This change order is not effective until approved by County. If the Contractor does not sign acceptance of this order, his attention is directed to the requirements of the specifications as to proceeding with the ordered work and filing a written protest with the time therein specified.

Megan Kathriner
Accepted _____
Contractor Date

John Ashlock 5/8/25
Approval Recommended Date
John Ashlock, Engineering Division Manager

Dennis Acuna 5/12/2025
Approved Date
Dennis Acuna, Director of Transportation

Approved _____ Date
Chairman, Riverside County Board of Supervisors



COUNTY OF RIVERSIDE
TRANSPORTATION DEPARTMENT

SHEET 2 OF 2 SHEETS

Contract Change Order No. 1

CONTRACT: **Indiana Avenue Resurfacing
Grant Street and Harlow Avenue Resurfacing**

WORK ORDER NO.
CALTRANS EA NO.
LOCAL-FED AID NO.
STATE-FED AID NO.

C6-0080, D2-0022
N/A
N/A
N/A

This Change Order may be executed in any number of counterparts, each of which will be an original, but all of which together will constitute one instrument. Each party to this Change Order agrees to the use of electronic signatures, such as digital signatures that meet the requirements of the California Uniform Electronic Transactions Act ("CUETA") Cal. Civ. Code §§ 1633.1 to 1633.17, for executing this Change Order. The parties further agree that the electronic signatures of the parties included in this Change Order are intended to authenticate this writing and to have the same force and effect as manual signatures. Electronic signature means an electronic sound, symbol, or process attached to or logically associated with an electronic record and executed or adopted by a person with the intent to sign the electronic record pursuant to the CUETA as amended from time to time. The CUETA authorizes use of an electronic signature for transactions and contracts among parties in California, including a government agency. Digital signature means an electronic identifier, created by computer, intended by the party using it to have the same force and effect as the use of a manual signature, and shall be reasonably relied upon by the parties. For purposes of this section, a digital signature is a type of "electronic signature" as defined in subdivision (i) of Section 1633.2 of the Civil Code.

WE, the undersigned contractor, have given careful consideration to the change proposed and hereby agree that we will provide all equipment, furnish all materials, except as may otherwise be noted above, and perform all services necessary for the work above specified, and will accept as full payment therefor the prices shown above. By reason of this proposed change 0 days adjustment of time will be allowed.

NOTE: This change order is not effective until approved by County. If the Contractor does not sign acceptance of this order, his attention is directed to the requirements of the specifications as to proceeding with the ordered work and filing a written protest with the time therein specified.

Megan Kathriner

Accepted _____
Contractor Date

John Ashlock 5/18/25
Approval Recommended Date
John Ashlock, Engineering Division Manager

Approved _____ Date
Dennis Acuna, Director of Transportation

V. Manuel Perez JUN 24 2025
Approved Date
Chairman, Riverside County Board of Supervisors

V. MANUEL PEREZ
FORM APPROVED COUNTY COUNSEL
BY: *Danielle D. Maland*
DANIELLE D. MALAND

ATTEST:
KIMBERLY A. RECTOR, Clerk
By *Kimberly A. Rector*
DERUTY

CCO No. 1 Indiana Ave Grant St Harlow Ave

Final Audit Report

2025-05-07

Created:	2025-05-06
By:	Desiree Auelua (deaelua@rivco.org)
Status:	Signed
Transaction ID:	CBJCHBCAABAAEVgA5IdU0ytbq3wexvoqxvPOPFJh6d2S

"CCO No. 1 Indiana Ave Grant St Harlow Ave" History



Document created by Desiree Auelua (deaelua@rivco.org)

2025-05-06 - 3:16:05 PM GMT- IP address: 158.61.6.5



Document emailed to megank@hardyandharper.com for signature

2025-05-06 - 3:19:12 PM GMT



Email viewed by megank@hardyandharper.com

2025-05-06 - 6:39:30 PM GMT- IP address: 104.28.76.101



Signer megank@hardyandharper.com entered name at signing as Megan Kathriner

2025-05-07 - 7:08:29 PM GMT- IP address: 64.58.138.50



Document e-signed by Megan Kathriner (megank@hardyandharper.com)

Signature Date: 2025-05-07 - 7:08:31 PM GMT - Time Source: server- IP address: 64.58.138.50



Agreement completed.

2025-05-07 - 7:08:31 PM GMT



Adobe Acrobat Sign

**COUNTY OF RIVERSIDE
TRANSPORTATION DEPARTMENT**

INDEX OF SHEETS

SHEET No.	DESCRIPTION
1	TITLE
2	LAYOUT

KLYNE ST

RECONSTRUCTION

BOBBIT ST TO BEDFORD CANYON RD

**COMMUNITY OF
EL CERRITO**

TO BE SUPPLEMENTED BY CALTRANS 2018 STANDARD PLANS AND
COUNTY OF RIVERSIDE ROAD STANDARDS DATED MARCH 2, 2023

ABBREVIATIONS

AP	ANGLE POINT	RAP	RECYCLED AGGREGATE PAVEMENT
ARHM	ASPHALT RUBBER HOT MIX	RCP	REINFORCED CONCRETE PIPE
BLDG	BUILDING	SCG	SOUTHER CALIFORNIA GAS
CB	CATCH BASIN	UB	UTILITY BOX
CF	CURB FACE		
CIR	COLD IN PLACE RECYCLING		
CVWD	COACHELLA VALLEY WATER DISTRICT		
C/G	CURB AND GUTTER		
GV	GAS VALVE		
MB	MAIL BOX		

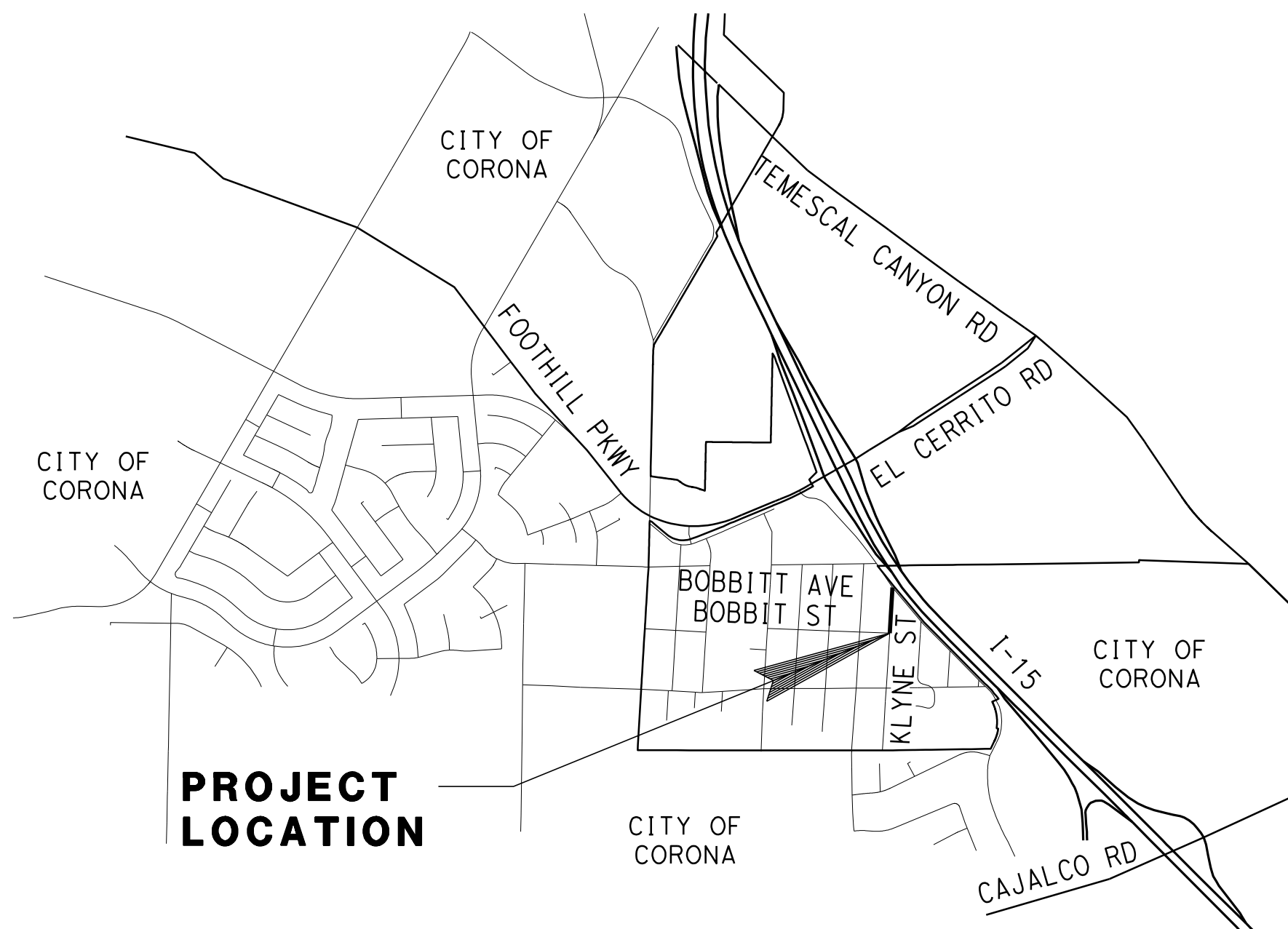
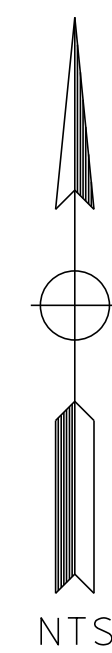
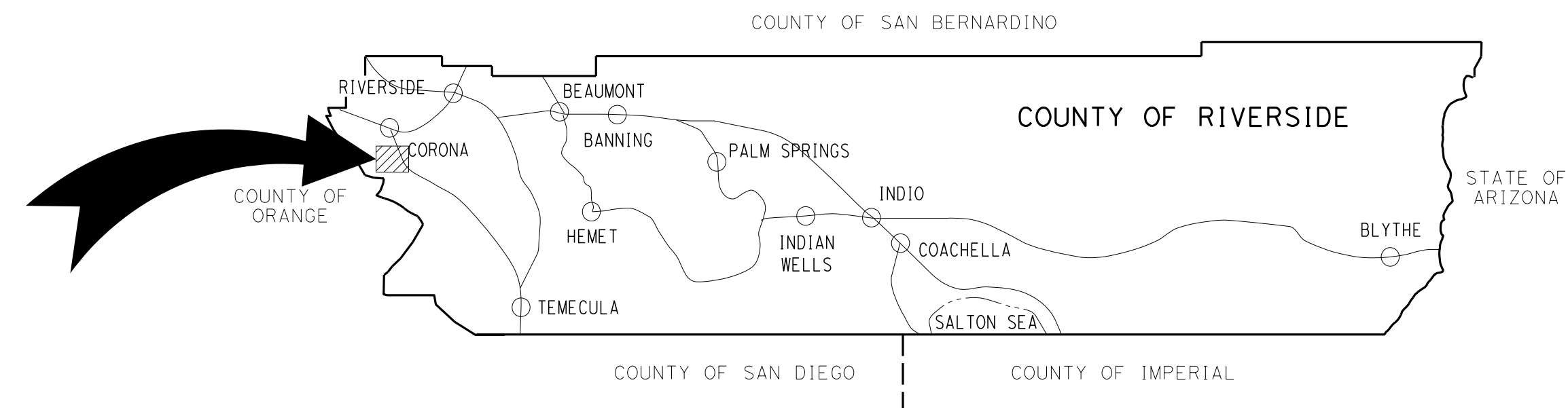

PROJECT LOCATION

VICINITY MAP

TOWNSHIP 4S RANGE 6W SECTION 17
COUNTY ROAD BOOK PAGE No. 30B

CONCURRED BY	PREPARED BY	TITLE	SHEET No.
DENNIS ACUNA DIRECTOR OF TRANSPORTATION COUNTY OF RIVERSIDE	MICHAEL C AGUILAR ENGINEERING PROJECT MANAGER COUNTY OF RIVERSIDE	KLYNE ST RECONSTRUCTION NO SCALE	SHEET 1 OF 2

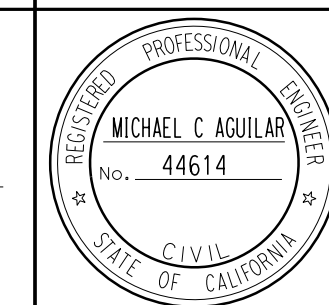

THE CONTRACTOR SHALL NOTIFY UNDERGROUND SERVICE ALERT, (800) 227-2600, AND ALL CONCERNED UTILITY COMPANIES AT LEAST TWO WORKING DAYS IN ADVANCE OF EXCAVATION

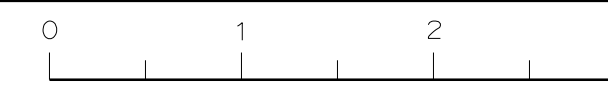

CONSTRUCTION NOTES:

- ① PROTECT
- ② PULVERIZE EXISTING ASPHALT PAVEMENT; PERFORM MOISTURE-CONDITION, GRADE AND COMPACT TO 95% RELATIVE COMPACTION PAVE WITH 0.35' HMA IN TWO LIFTS OF 0.15' (1/2" MIX) OVER 0.20' (3/4" MIX) OVER THE PREPARED SUBGRADE
- ③ CONSTRUCT 6" HMA DIKE PER STD No. 212
- ④ CONSTRUCT HEADER CUT PER "HEADER CUT" DETAIL
- ⑤ CONSTRUCT 4" THICK ASPHALT CONCRETE DRIVEWAY PER "DRIVEWAY" DETAIL
- ⑥ CONSTRUCT SAFETY EDGE WITH SHOULDER BACKING PER STD No. 214
- ⑦ REMOVE AND/OR TRIM TREES AND/OR STUMPS
- ⑧ TRANSITION DIKE TO 0" CF
- ⑨ ADJUST WATER VALVE(S), INCLUDING THE ASSOCIATED VALVES FOR FIRE HYDRANTS THAT ARE COVERED BY DIRT/ASPHALT

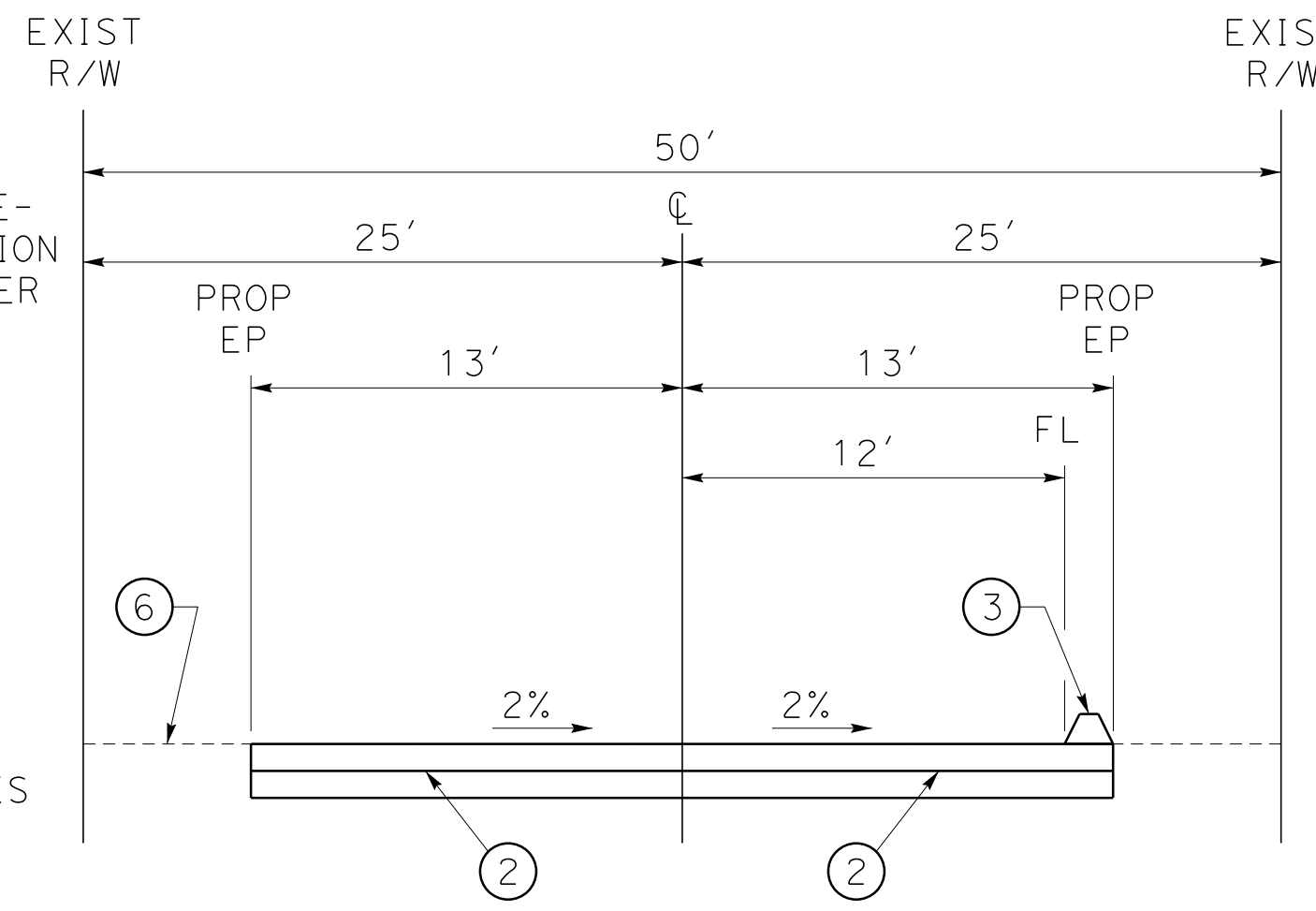

KLYNE ST

STA 99+62 TO STA 104+42
NTS

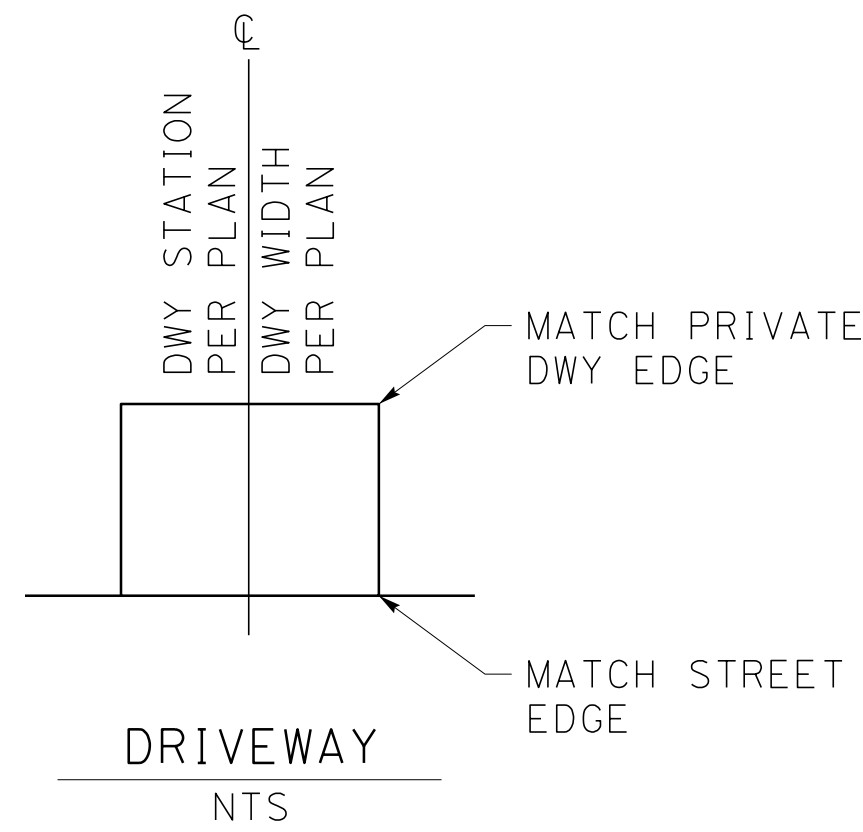
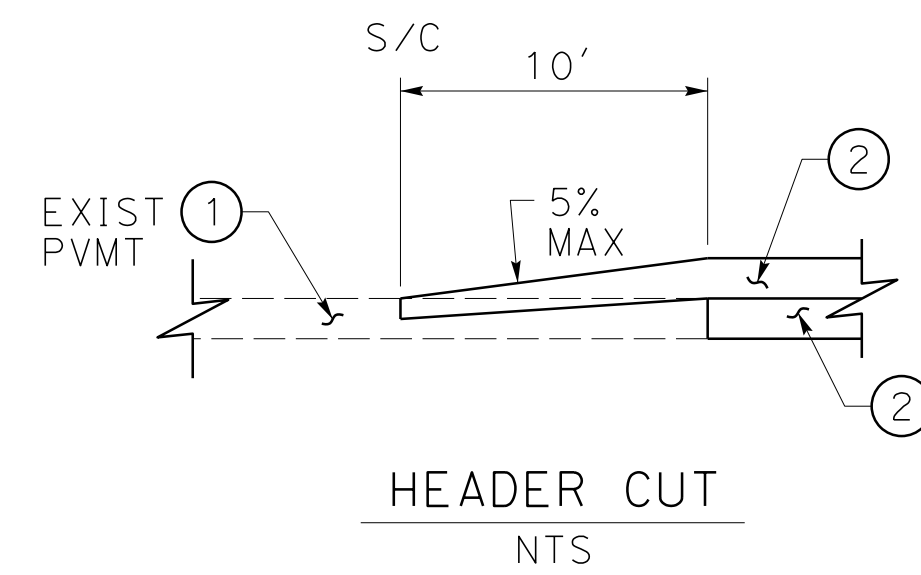

SIGN SIZE	
R1-1	30" X 30"

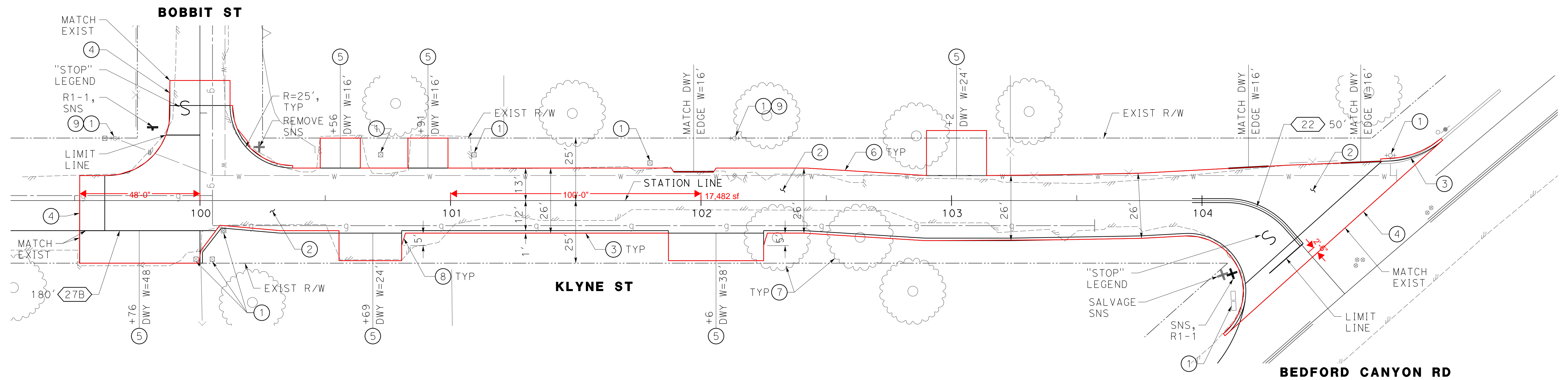
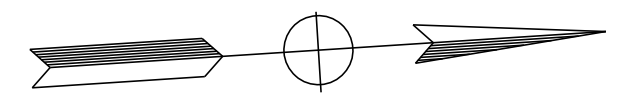

	PREPARED BY	LAYOUT	SHEET No.
	PREPARED UNDER THE SUPERVISION OF: MICHAEL C. AGUILAR ENGINEERING PROJECT MANAGER COUNTY OF RIVERSIDE	KLYNE ST RECONSTRUCTION SCALE: 1"=20'	L-1 SHEET 2 OF 2

P:\D5-0053 BOBBITT AVE RECONING_CADD\G200 FINAL PLAN SET\SH105-0053a ea L-01.sht



DATE PLOTTED => 1/8/2025
 TIME PLOTTED => 9:11:55 AM

CHANGE ORDER REPORT
(Indiana Ave. Resurfacing, Grant St. and Harlow Ave. Resurfacing Project)

CCO #	Amount	Percent	Description
	Original Contract Amount \$3,185,000.00		
1	\$263,437.08	8.27%	Reconstruction of Klyne Street, Project No. D5-0053
Total Change Orders	\$263,437.08	8.27%	
Revised Contract Amount	\$3,448,437.08		

**COUNTY OF RIVERSIDE
TRANSPORTATION DEPARTMENT**

INDIANA AVENUE RESURFACING

BARKER LANE TO 150-FOET EAST OF HILLVIEW DRIVE

COMMUNITY OF HOME GARDENS

PROJECT No. C6-0080

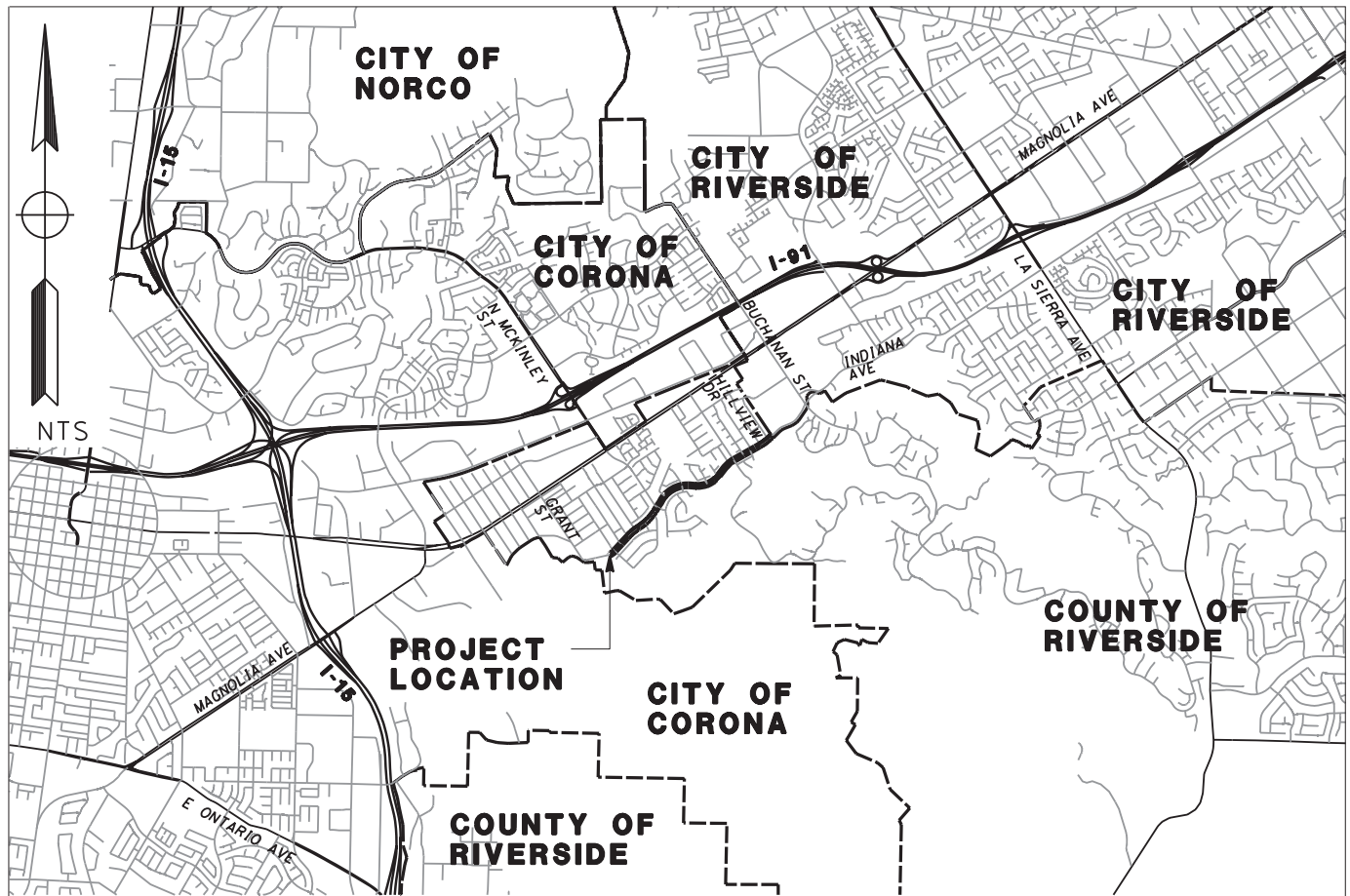
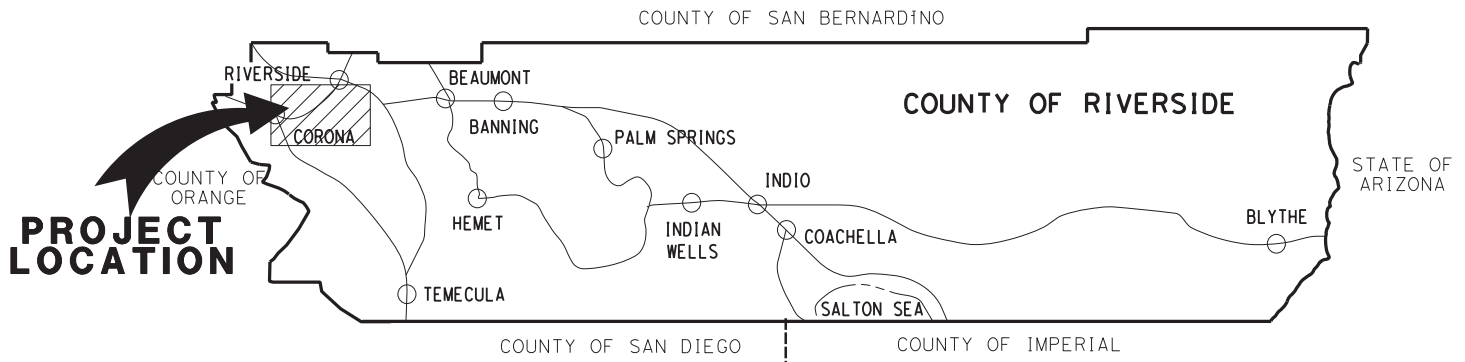

VICINITY MAP

COUNTY OF RIVERSIDE
TRANSPORTATION DEPARTMENT

GRANT STREET AND HARLOW AVENUE RESURFACING

GRANT STREET FROM HARLOW AVENUE TO MAGNOLIA AVENUE
HARLOW AVENUE FROM GRANT STREET TO MCKINLEY STREET

COMMUNITY OF HOME GARDENS

PROJECT No. D2-0022

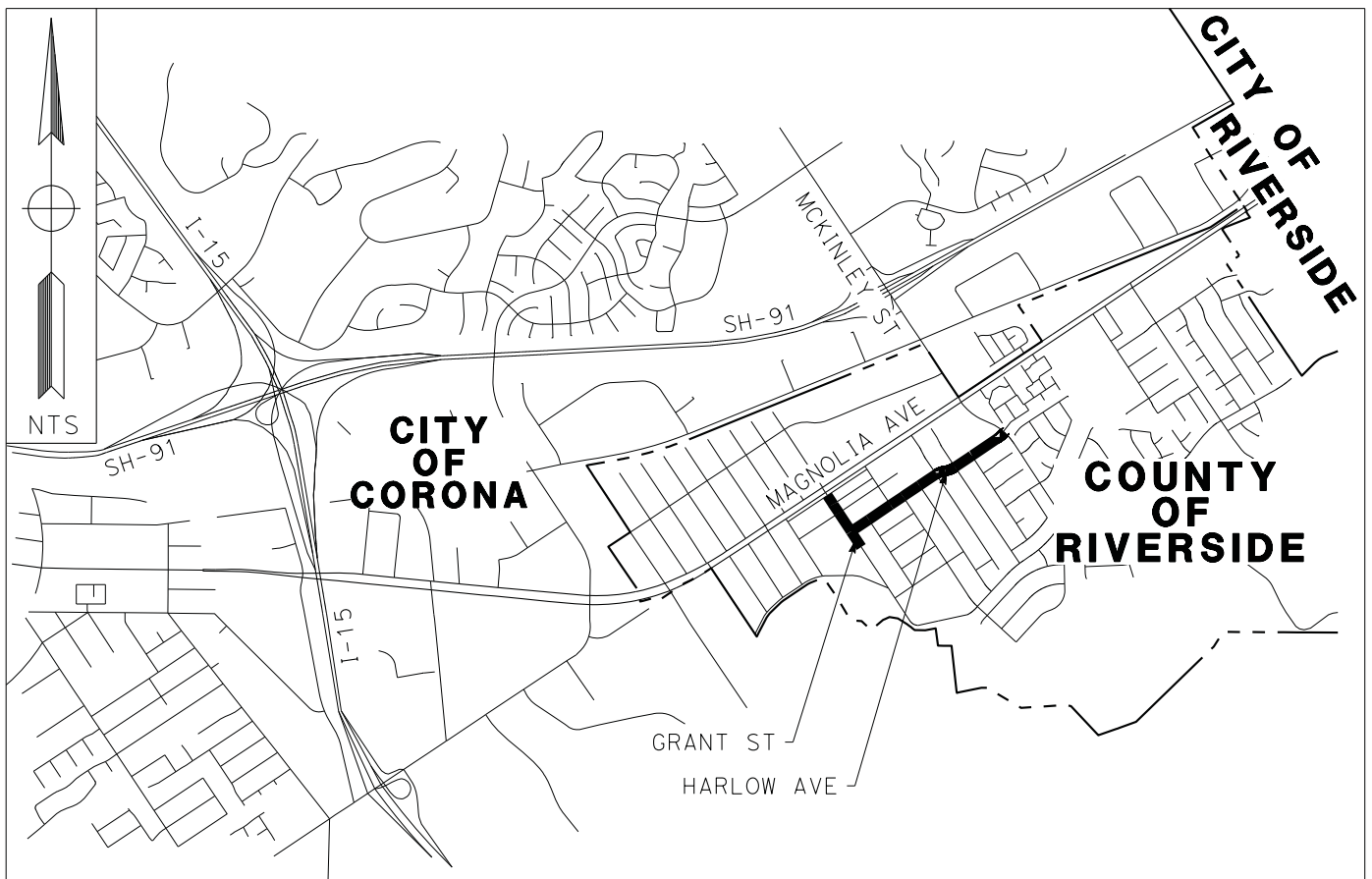
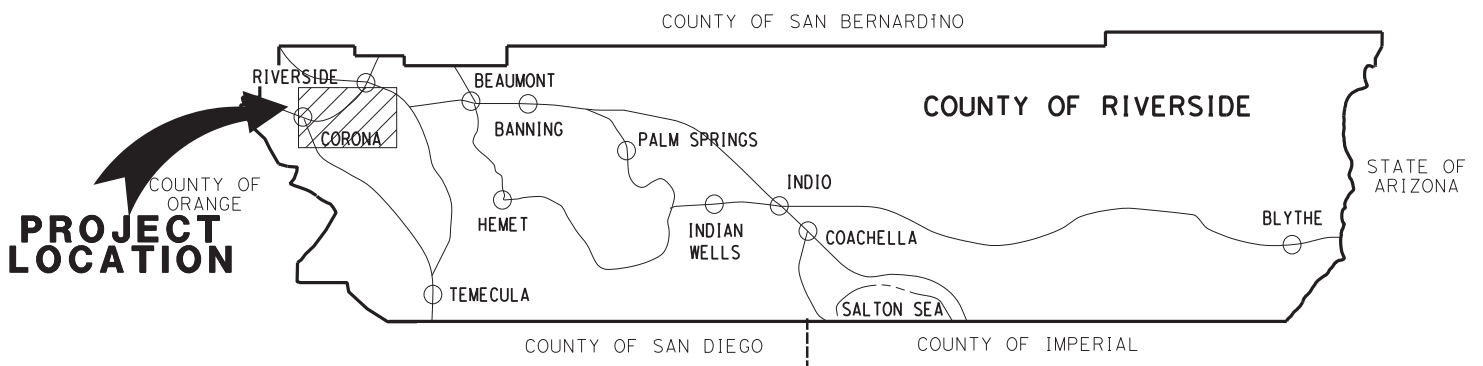

VICINITY MAP