

MINUTES OF THE BOARD OF SUPERVISORS
COUNTY OF RIVERSIDE, STATE OF CALIFORNIA



AGENDA NO.
22.5
(MT 29116)

10:00 a.m. being the time set for public hearing on the recommendation from Transportation And Land Management Agency/Planning regarding public hearing on the Initiation Of Foundation Component General Plan Amendment No. 240052 (GPA240052) – Request: The applicant requests that the County of Riverside consider whether to recommend the initiation of GPA240052 to change the General Plan Foundation Component of one (1) parcel from Rural Community: Very Low Density Residential (RC: VLDR) to Community Development: Low Density Residential (CD: LDR), to allow for submittal of an application for sixteen (16) custom homes on a half acre (0.5) lot. Additional development applications and review by the County to confirm that the overall project complies with applicable standards, policies, findings, and other requirements will be required if the proposed GPA240052 is initiated by the Board of Supervisors. – Fifth Supervisorial District – Cherry Valley District – The Pass Area Plan – Applicant: Dilip Sheth – Existing Zoning: A-1-1 (Light Agriculture) – Existing Land Use: Rural Community: Very Low Density Residential (RC:VLDR) – Location: north of Brookside Ave., east of Union St., south of Cherry Valley Blvd., and west of Nancy Ave. – APN(s): 405-180-006 – 9.44 Gross Acres - Not a Project under CEQA - District 5.

On motion of Supervisor Perez, seconded by Supervisor Spiegel and duly carried, IT WAS ORDERED that the above matter is continued to Tuesday, January 13, 2026, at 10:00a.m. or as soon as possible thereafter.

Roll Call:
Ayes: Spiegel, Washington, and Perez
Nays: None
Absent: Medina
Recused: Gutierrez

I hereby certify that the foregoing is a full true, and correct copy of an order made and entered on December 16, 2025 of Supervisors Minutes.

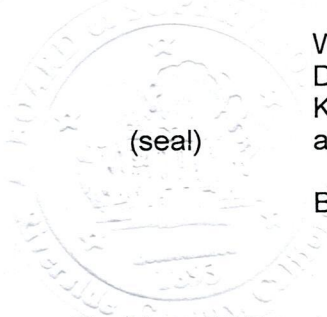

(seal)

WITNESS my hand and the seal of the Board of Supervisors
Dated: December 16, 2025
Kimberly A. Rector, Clerk of the Board of Supervisors, in
and for the County of Riverside, State of California.

By: _____ Deputy

AGENDA NO.
22.5

xc: Planning, COB

SUBMITTAL TO THE BOARD OF SUPERVISORS
COUNTY OF RIVERSIDE, STATE OF CALIFORNIA



ITEM: 22.5
(ID # 29116)

MEETING DATE:

Tuesday, December 16, 2025

FROM : TLMA-PLANNING

SUBJECT: TRANSPORTATION AND LAND MANAGEMENT AGENCY/PLANNING: INITIATION OF FOUNDATION COMPONENT GENERAL PLAN AMENDMENT NO. 240052 (GPA240052) – REQUEST: The applicant requests that the County of Riverside consider whether to recommend the initiation of GPA240052 to change the General Plan Foundation Component of one (1) parcel from Rural Community: Very Low Density Residential (RC: VLDR) to Community Development: Low Density Residential (CD: LDR), to allow for submittal of an application for sixteen (16) custom homes on a half acre (0.5) lot. Additional development applications and review by the County to confirm that the overall project complies with applicable standards, policies, findings, and other requirements will be required if the proposed GPA240052 is initiated by the Board of Supervisors. – Fifth Supervisorial District – Cherry Valley District – The Pass Area Plan – Applicant: Dilip Sheth – Existing Zoning: A-1-1 (Light Agriculture) – Existing Land Use: Rural Community: Very Low Density Residential (RC:VLDR) – Location: north of Brookside Ave., east of Union St., south of Cherry Valley Blvd., and west of Nancy Ave. – APN(s): 405-180-006 – 9.44 Gross Acres - Not a Project under CEQA - District 5 [Applicant Fees 100%]. (CONTINUE TO JANUARY 13th 2026 BOARD OF SUPERVISORS HEARING)

THAT THE BOARD OF SUPERVISORS TAKE THE FOLLOWING ACTION:

1. **CONSIDER** whether to recommend the initiation of FOUNDATION COMPONENT GENERAL PLAN AMENDMENT NO. 240052 (GPA240052); and,
2. If recommended, **ADOPT** an order initiating FOUNDATION COMPONENT GENERAL PLAN AMENDMENT NO. 240052 (GPA240052) and requiring the applicant submit to the County the project within 6 months.

ACTION:Policy

John Hildebrand, Planning Director

12/5/2025

Rania Odenbaugh, TLMA Director

12/9/2025

MINUTES OF THE BOARD OF SUPERVISORS

**SUBMITTAL TO THE BOARD OF SUPERVISORS COUNTY OF RIVERSIDE,
STATE OF CALIFORNIA**

FINANCIAL DATA	Current Fiscal Year:	Next Fiscal Year:	Total Cost:	Ongoing Cost
COST	\$ 0	\$ 0	\$ 0	\$ 0
NET COUNTY COST	\$ 0	\$ 0	\$ 0	\$ 0
SOURCE OF FUNDS: Applicant Fees 100%			Budget Adjustment:	No
			For Fiscal Year:	25-26

C.E.O. RECOMMENDATION: Approve

BACKGROUND:

Summary

The Foundation Component General Plan Amendment No. 240052 (GPA240052) is a proposal to amend the project site's Foundation Component from Rural Community (RC) to Community Development (CD) and amend its Land Use Designation from Very Low Density Residential (RC:VLDR) to Low Density Residential (CD:LDR), on 1 parcel, totaling 9.44 gross acres, in order to allow for submittal of an application for sixteen (16) custom homes on a half-acre (0.5) lots.

The one (1) parcel is located south of Cherry Valley Blvd, north of Brookside Ave, east of Nancy Ave, and west of Virginia Ln.

The proposed Foundation Component General Plan Amendment (FC-GPA) is an initiation procedure per the General Plan which occurs in eight (8) year cycles, most recently occurring in 2024. All property owners and applicants wanting to change their Foundation Components are required to submit their proposals for land use designation changes to the County of Riverside for consideration and possible initiation by the Board of Supervisors.

Further determination of zoning classifications, neighborhood compatibility, and other development factors or findings shall be made if the proposed FC-GPA (GPA240052) is initiated by the Board of Supervisors. Any FC-GPA initiated by the Board of Supervisors will require the submittal of an implementing project within six (6) months from initiation.

Applicant Proposal

FC-GPA240052 is a proposal to change the Foundation Component Land Use Designation from Rural Community: Very Low Density Residential (RC: VLDR) to Community Development: Low Density Residential (CD: LDR), to allow for single family detached residences on large parcels 0.5 to 1 acre,

**SUBMITTAL TO THE BOARD OF SUPERVISORS COUNTY OF RIVERSIDE,
STATE OF CALIFORNIA**

to allow for custom homes on half acre lot.

The parcel is located in the Cherry Valley policy area / overlay, within The Pass Area Plan.

If FC-GPA240052 is approved by the Board of Supervisors, the applicant intends to apply for an implementing project consisting of single family detached residences on large parcels 0.5 to 1 acre.

Proposed Future Land Use

The proposed Community Development (CD) Foundation encompasses many underlying land use designations. The most intensive land use designation permitted within the CD Foundation is the Heavy Industrial (CD-HI) land use designation, which allows for more intense industrial activities that generate greater effects such as excessive noise, dust, and other nuisances.

The Proposed High Density Residential (CD-HDR) land use designation is intended to allow for single-family attached and detached residences. This includes townhouses, stacked flats, courtyard homes, patio homes, and zero lot line homes. The density range is 8-14 dwelling units per acre.

Changes to Applicant Proposal

On May 12, 2025 at the GPAC meeting the proposal included affordable housing such as mobile homes. Based on comments from the committee and the public, the project was revised. On September 3, 2025 at the Planning Commissioners meeting, the project proposed single family detached residences on large parcels 0.5 to 1 acre. No changes were made after presentation of the project proposal to the PC.

PUBLIC HEARING NOTIFICATION AND COMMUNITY OUTREACH

This project was advertised on the Riverside County Planning Department website. Additionally, public hearing notices in English and Spanish, pursuant to department policy and in accordance with the requirements of Ordinance 348, were mailed to property owners within 600 feet of the project site for the General Plan Advisory Committee, Planning Commission, and Board of Supervisors public hearings.

Eight (8) comments were received to date. Comments indicated concerns about traffic and wanting to keep the area as a rural community.

**SUBMITTAL TO THE BOARD OF SUPERVISORS COUNTY OF RIVERSIDE,
STATE OF CALIFORNIA**

One (1) comment was received after the close of the GPAC public hearing. Comment indicated concerns about traffic and polluting the water.

No comments were received after the close of the Planning Commission public hearing and as of the writing of this staff report.

General Plan Advisory Committee Proceedings

A duly noticed public hearing to discuss FC-GPA240052 was held before the General Plan Advisory Committee on March 10, 2025. Four (4) number of comments were submitted before the General Plan Advisory Committee meeting. At that public hearing, the applicant presented their request for the proposal, the Committee opened the hearing for public comments, and four (4) members of the public provided public testimony.

Of the public comments received, four (4) were against initiation of a General Plan Amendment, and zero (0) were in support. Concerns by the public were regarding traffic, transportation, low density housing and keeping the area rural for a slower paced environment.

The Committee discussed the project. Issues that were discussed included concerns about traffic, staying with a rural lifestyle, water management, and wildlife in the area. The final result of the Committee's discussion of the initiation is provided below.

Support:

Against: 2nd Districts

Neutral:

Not Present: 1st, 3rd, 4th, 5th District

Abstain:

Planning Commission Proceedings

A duly noticed public hearing to discuss FC-GPA 240052 was held before the Planning Commission on September 03, 2025. At that public hearing, the applicant presented their request for the proposal, and the Commission opened the hearing for public comments. Twelve (12) members of the public provided public testimony.

Of the public comments received, ten (10) were against initiation of a General Plan Amendment, and none were in support. Comments against the initiation of the GPA were concerns about lacking roads, fire service, infrastructure, animal keeping, and rural area.

**SUBMITTAL TO THE BOARD OF SUPERVISORS COUNTY OF RIVERSIDE,
STATE OF CALIFORNIA**

The Committee discussed the project. Issues that were discussed included the aforementioned public concerns, as well as, recommendations for robust community outreach and input. The final result of the Planning Commission's discussion of the initiation is provided below.

Support: 1st and 4th District
Against: 5th Districts
Neutral: 2nd and 3rd District
Not Present:
Abstain:

Impact on Residents and Businesses

The proposed Foundation Component General Plan Amendment is merely a request to initiate a General Plan Amendment, not the General Plan Amendment itself. Thus, the request today is not a project under the California Environmental Quality Act (CEQA) and no impact on residents will occur at this stage. If the Foundation Component General Plan Amendment request is approved as recommended, within 6 months the applicant must submit an implementing project along with the initiated General Plan Amendment. All impacts on residents and businesses will be considered at the time the implementing project is heard.

Additional Fiscal Information

All fees are paid by the applicant. There is no General Fund obligation.

ATTACHMENTS:

- Attachment A – Vicinity Maps**
- Attachment B – Existing Land Use Designations**
- Attachment C – Existing Zoning Classifications**
- Attachment D – Noticing Radius and Labels**
- Attachment E – Applicant's Exhibits**
- Attachment F – GPAC Hearing Package**
- Attachment G – PC Hearing Package**

Crystal Carrillo, Senior Management Analyst 12/10/2025

RIVERSIDE COUNTY PLANNING DEPARTMENT

GPA240052

VICINITY/POLICY AREAS

Supervisor: YXSTIAN GUTIERREZ

Date: 10-27-2025

District: 5



Zoning Area/District: CHERRY VALLEY

DISCLAIMER: On October 7, 2003, the County of Riverside adopted a new General Plan providing new land use designations for unincorporated Riverside County parcels. The new General Plan may contain different type of land use than is provided for under existing zoning. For further information, please contact the Riverside County Planning Department offices in Riverside at (951)955-3200 (Western County) or in Palm Desert at (760)863-8277 (Eastern County) or Website <http://planning.rctlma.org>

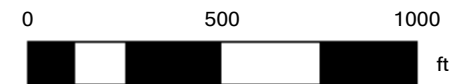

Foundation Component GPA Cycle Map

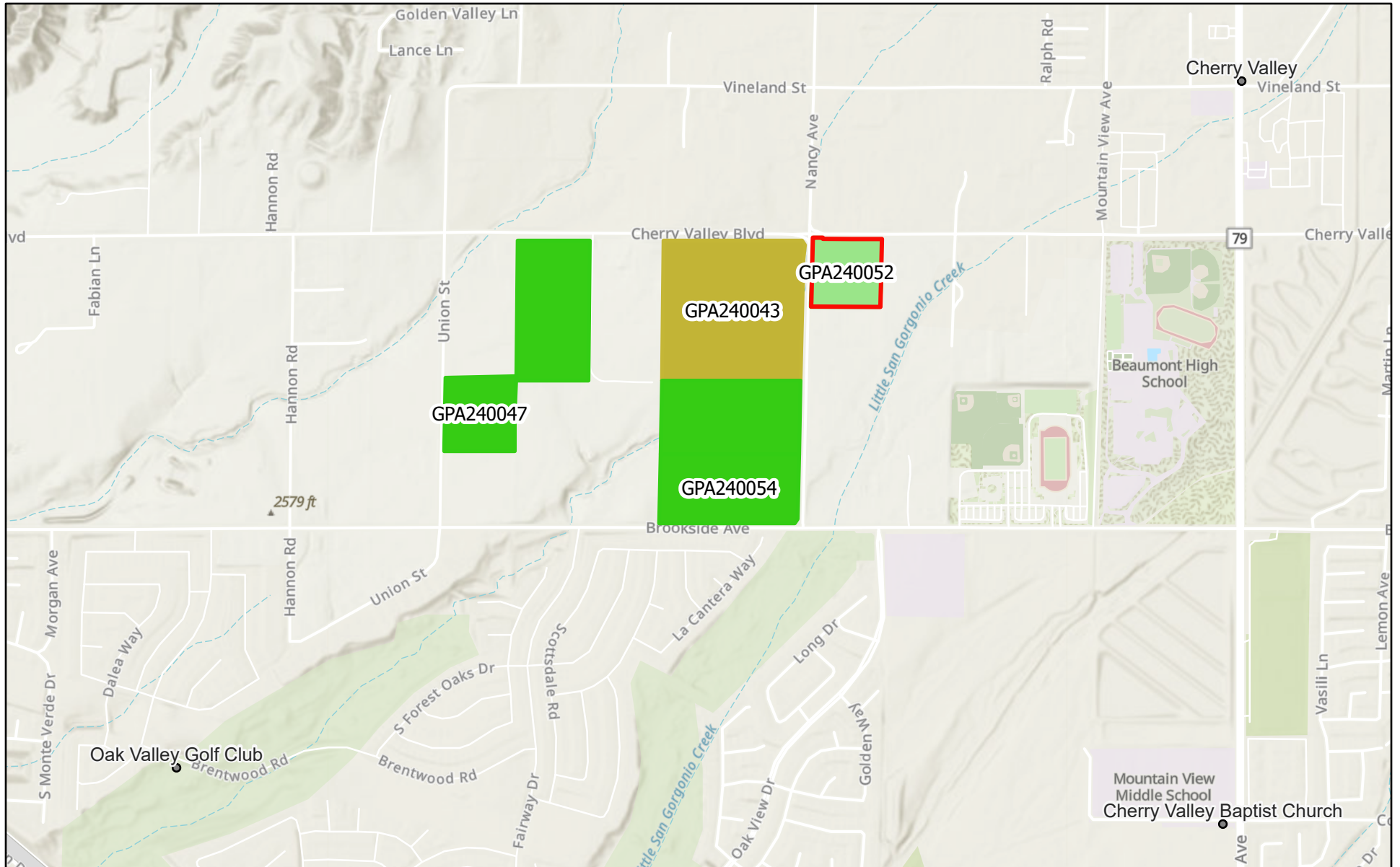

10-27-2025, 8:53 AM

 FGPA Web Map _Query result

 California Geographic Names Information System

FGPA Web Map

 Active

 On Hold

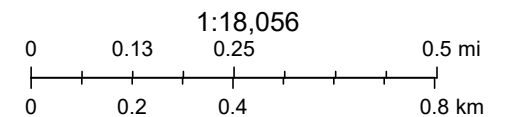

Esri, NASA, NGA, USGS, FEMA, Sources: Esri, TomTom, Garmin, FAO, NOAA, USGS, © OpenStreetMap contributors, and the GIS User Community

TLMA - Planning

RIVERSIDE COUNTY PLANNING DEPARTMENT

GPA240052

EXISTING GENERAL PLAN

Supervisor: YXSTIAN GUTIERREZ

Date: 10-27-2025

District: 5

Exhibit: 5

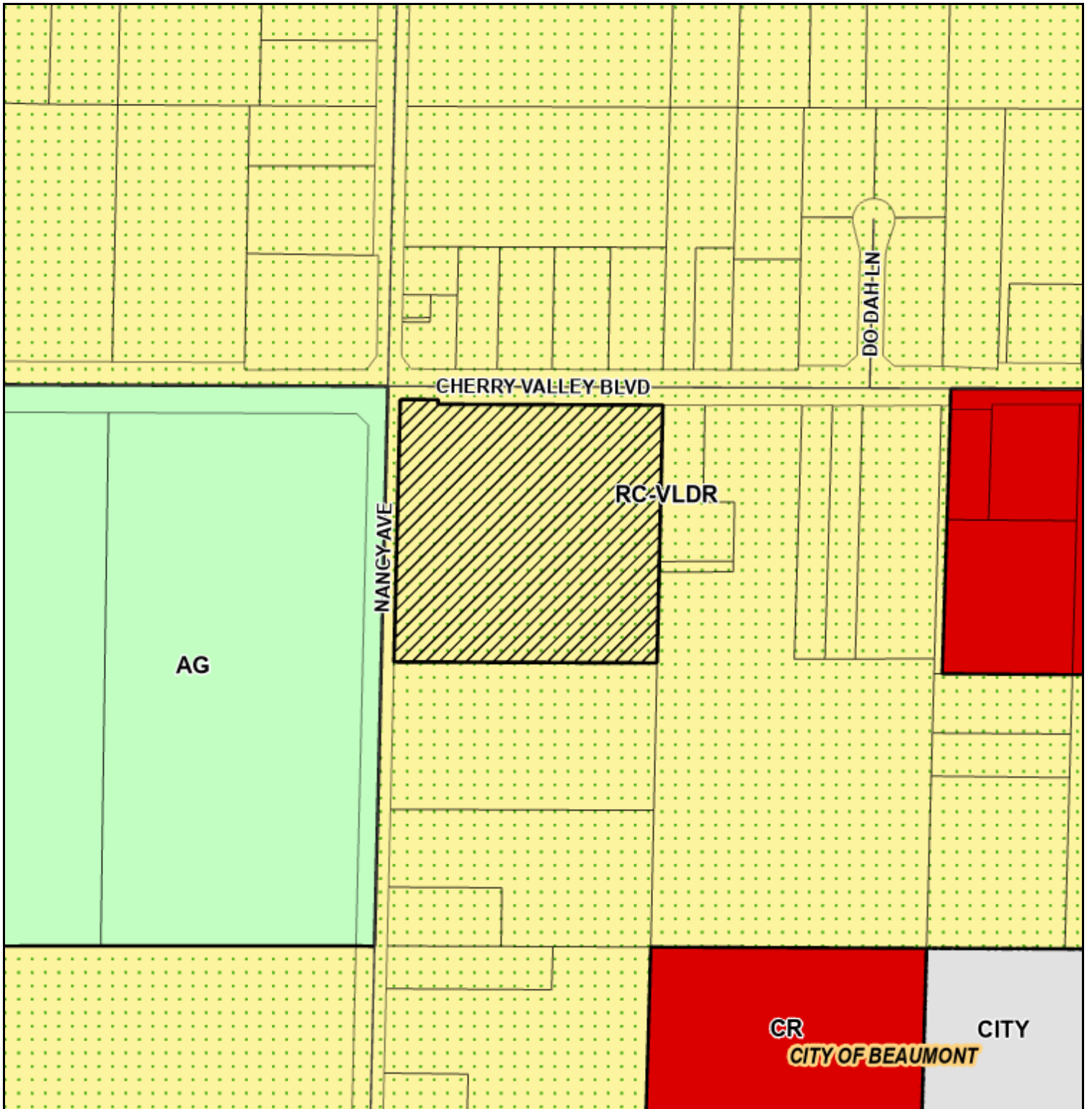

Zoning Area/District: CHERRY VALLEY

Author:

DISCLAIMER: On October 7, 2003, the County of Riverside adopted a new General Plan providing new land use designations for unincorporated Riverside County parcels. The new General Plan may contain different type of land use than is provided for under existing zoning. For further information, please contact the Riverside County Planning Department offices in Riverside at (951)955-3200 (Western County) or in Palm Desert at (760)863-8277 (Eastern County) or Website <http://planning.rctlma.org>



RIVERSIDE COUNTY PLANNING DEPARTMENT

GPA240052

EXISTING ZONING

Supervisor: YXSTIAN GUTIERREZ

District: 5

Date: 10-27-2025

Exhibit: 2

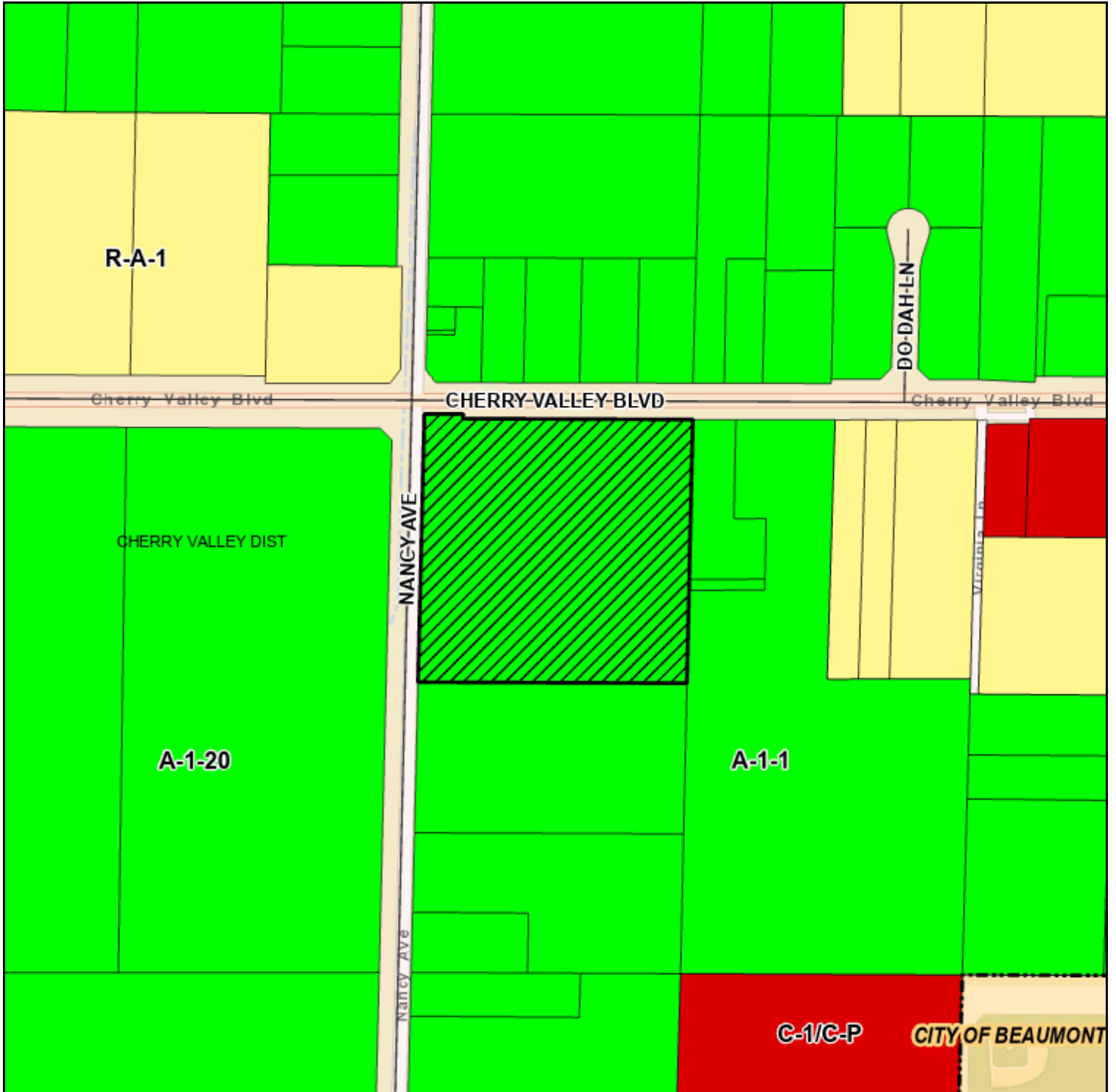

Zoning Area/District: CHERRY VALLEY

DISCLAIMER: On October 7, 2003, the County of Riverside adopted a new General Plan providing new land use designations for unincorporated Riverside County parcels. The new General Plan may contain different type of land use than is provided for under existing zoning. For further information, please contact the Riverside County Planning Department offices in Riverside at (951)955-3200 (Western County) or in Palm Desert at (760)863-8277 (Eastern County) or Website <http://planning.rctlma.org>

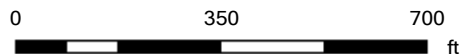



John E. Hildebrand
Planning Director

RIVERSIDE COUNTY

PLANNING DEPARTMENT

CERTIFICATION OF PUBLIC NOTICE

PROJECT NUMBER (FC-GPA240052)

Planning Case APN(s): 405-180-006

I, Candice Hughes certify that on October 28, 2025, the attached property owners list was prepared pursuant to notification procedures in Subsection 1.7.A.3. of Ordinance 348. Attached list is a complete and true compilation of the owners of the subject property and all other property owners within 400 feet of the property involved.

I further certify that the information filed is true and correct to the best of my knowledge.

NAME: Candice Hughes
TITLE: Principal Planner
ADDRESS: 4080 Lemon St 12th Fl., Riverside, CA 92501
PHONE: (951) 955-1639
EMAIL: chughes@rivco.org



SIGNATURE: *Candice Hughes*

Riverside County GIS Mailing Labels

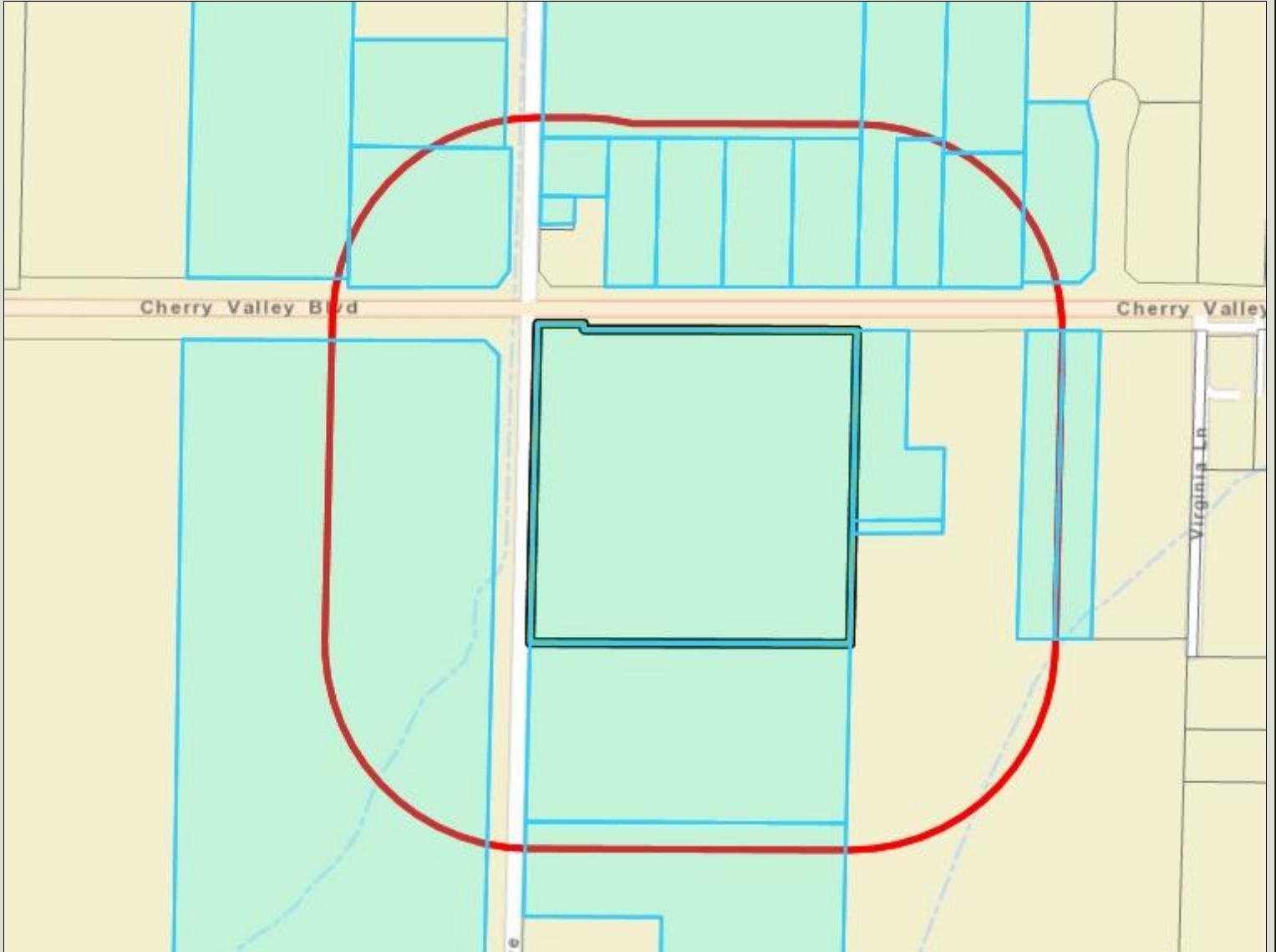
GPA240052



Legend

-  County Boundary
-  City
-  Parcel
-  World_Street_Map

Notes



0 376

752 Feet

IMPORTANT Maps and data are to be used for reference purposes only. Map features are approximate, and are not necessarily accurate to surveying or engineering standards. The County of Riverside makes no warranty or guarantee to the content (the source is often third party), accuracy, timeliness, or completeness of any of the data provided, and assumes no liability for the information contained on this map. Any use of this product with respect to accuracy and reception shall be the sole responsibility of the user.

REPORT PREPARED ON: 10/28/2025 11:36:55 AM

© Riverside County RCIT

405110001
WILLIA LA IN
9824 JONA HAN AVE
CHERRY VALLEY CA 92223

405110002
WILLIA SIMPSON
40666 DU ON
MØEAU N CA 92223

405110012
GRACIELA ES RADA
38656 CHERRY VALLEY LV
MØEAU N CA 92223

405110017
ASH ON CHRIS OPHER LINDEN
REVOCA LE LIVING RUS D D 4/12/2025
38648 CHERRY VALLEY LVD
MØEAU N CA 92223

405110018
JOSE PEREZ
38610 CHERRY VALLEY LVD
MØEAU N CA 92223

405110019
DARREN SURIO CAS ILLO
38656 CHERRY VALLEY LVD
MØEAU N CA 92223

405110020
CUR IS URHOP
38620 CHERRY VALLEY LVD
MØEAU N 92223

405110021
CLAUDIA JEAN NEWMAN
10498 NANCY AVE
MØEAU N CA 92223

405110022
JOSHUA J SHELLEY
38678 CHERRY VALLEY LVD
CHERRY VALLEY CA 92223

405110025
EDDY S AYALA
38634 CHERRY VALLEY LVD
MØEAU N CA 92223

405110026
WILLIA SIMPSON
245 N LI CHFIELD RD 142
GOODYEAR AZ 85338

405110030
~~DAN~~ L RVIN
38690 CHERRY VALLEY LVD
MØEAU N CA 92223

405170008
DARREN ONE I
10427 NANCY AVE
MØEAU N CA 92223

405170012
JOHN L ERN
38456 CHERRY VALLEY LVD
MØEAU N CA 92223

405170014
HOUSE OF CIVIL OPPORTUNITY
38416 CHERRY VALL Y BLV
CHERRY VALL Y CA 92223

405180003
KRISTINA M. VAN RBRUG
P O BOX 590
B AUMONT CA 92223

405180006
DOMINIQUE SHUA
904 SILVER PURNO 479
ROLLING HILL CA 90274

405180008
ANTONIO AMILY TRUTT AT 04/10/2023
10664 NANCY AV
B AUMONT CA 92223

405190007
IRMA NAVA
48712 RT LOWR R
PALM RT CA 92260

405190008
LIALBA RAMA
38705 CHERRY VALL Y BLV
CHERRY VALL Y CA 92223

405190010
OSTRIMARKA
38649 CHERRY VALL Y BLV
B AUMONT CA 92223

405190014
MARKA OSTRIMARKA
38649 CHERRY VALL Y BLV
CHERRY VALL Y CA 92223

405250007
CHERRY VALL Y PARTNER
32036 LIVE OAK CANYON R
R LANS CA 92373

CHERRY VALLEY ESTATES COUNTY OF RIVERSIDE SITE PLAN

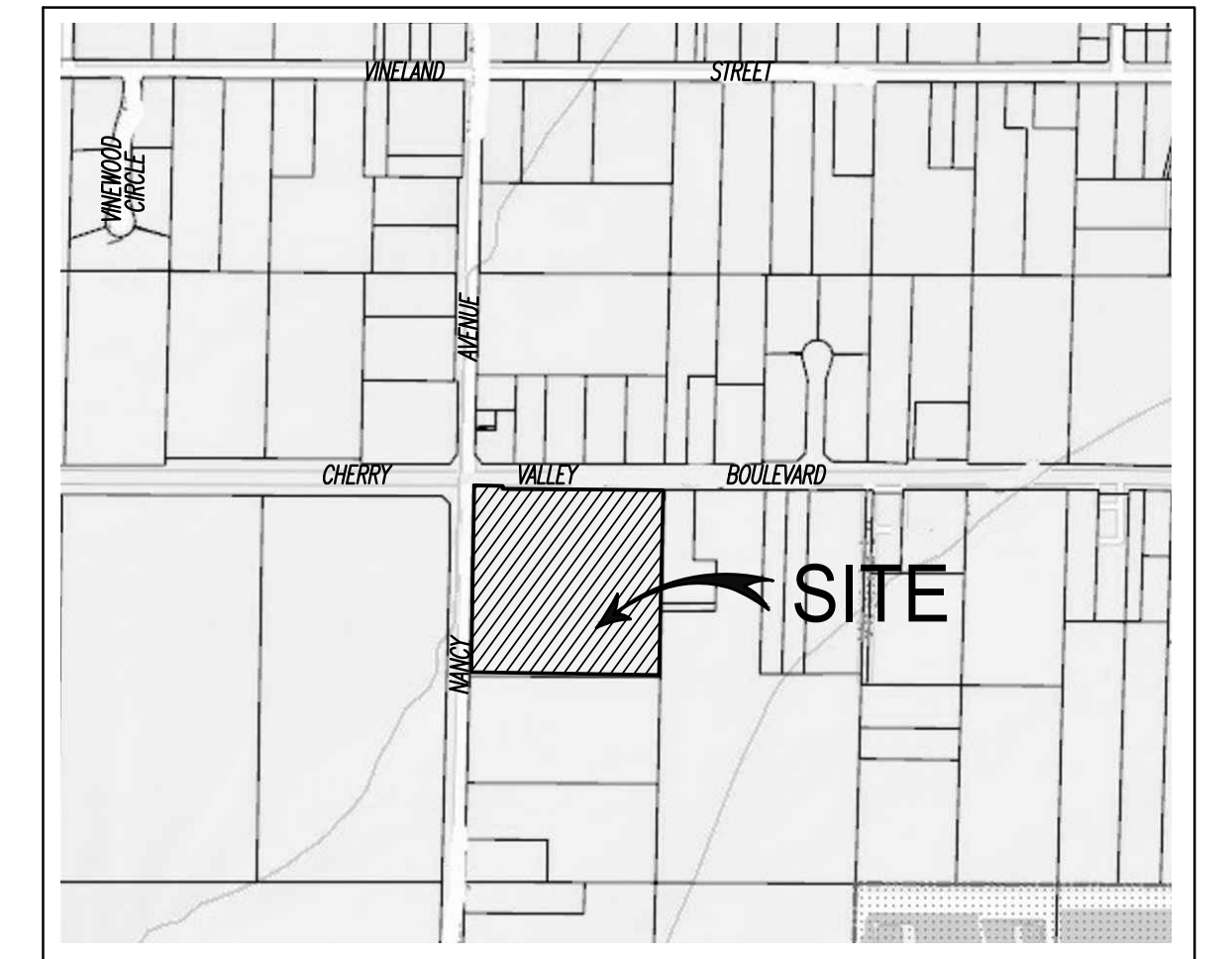

VICINITY MAP
N.T.S.

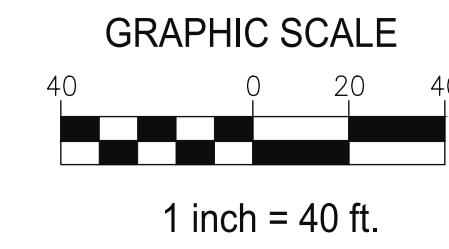
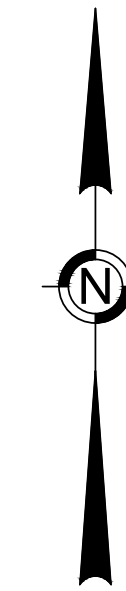

LEGAL DESCRIPTION:

THE NORTH HALF OF LOT 4 IN BLOCK 9 OF CHERRY VALLEY WEST ADDITION, IN THE COUNTY OF RIVERSIDE, STATE OF CALIFORNIA, AS SHOWN BY MAP ON FILE IN BOOK 6, PAGE 36 OF MAPS, RECORDS OF SAID COUNTY.

EXCEPTING THEREFROM THE SOUTH 25 FEET OF THE NORTH HALF OF SAID LOT 4.

ASSESSOR'S PARCEL NUMBER:

405-108-006

OWNER:

OM JOSHUA LLP
904 SILVER SPUR #479
ROLLING HILLS ESTATES, CA 90274

NOTES:

LOT "A" IS FOR R.V. PARKING AND UNDERGROUND INFILTRATION RETENTION AREA.

LEGEND

- BOUNDARY OF PROPERTY
- PROPOSED LOT LINE
- DIRECTION OF TRAVEL

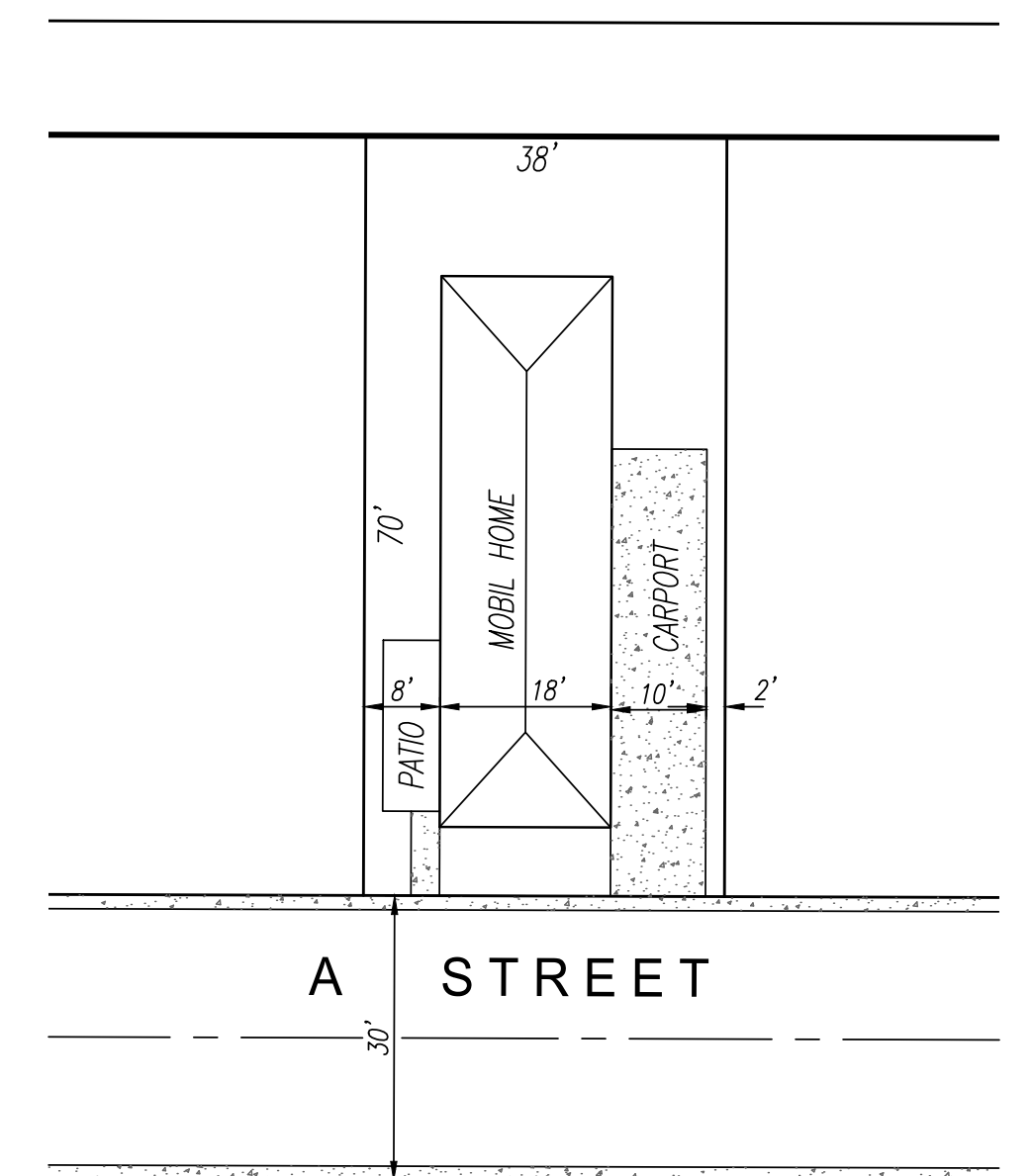

TYPICAL LOT LAYOUT

SCALE: 1"=20'

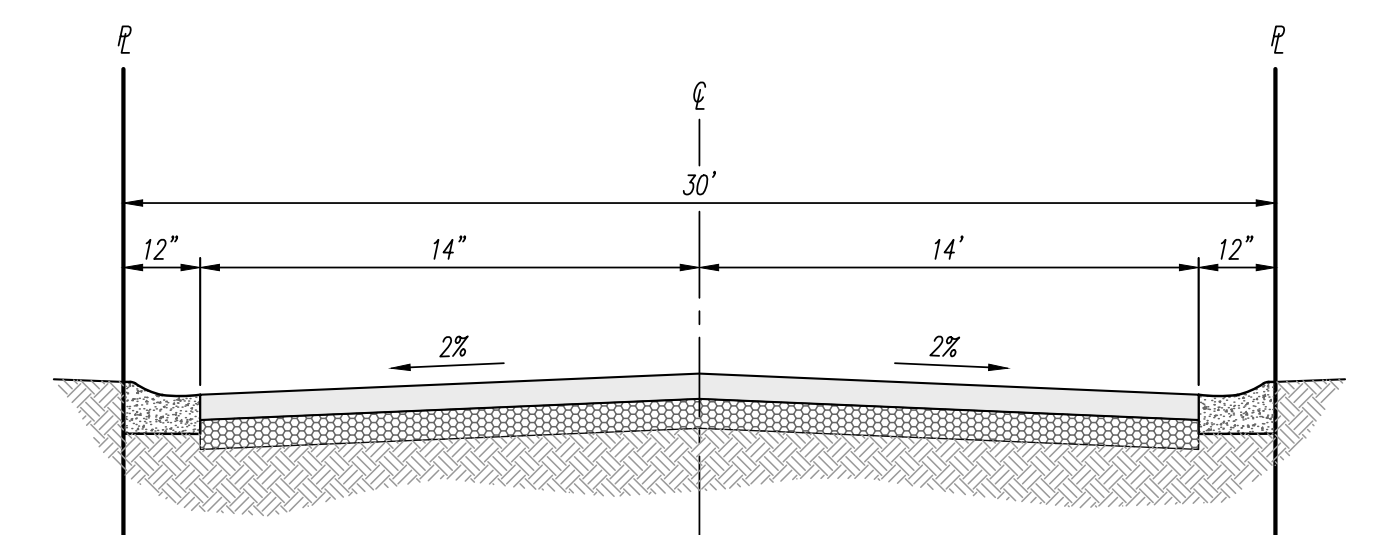

TYPICAL PRIVATE STREET

NOT TO SCALE

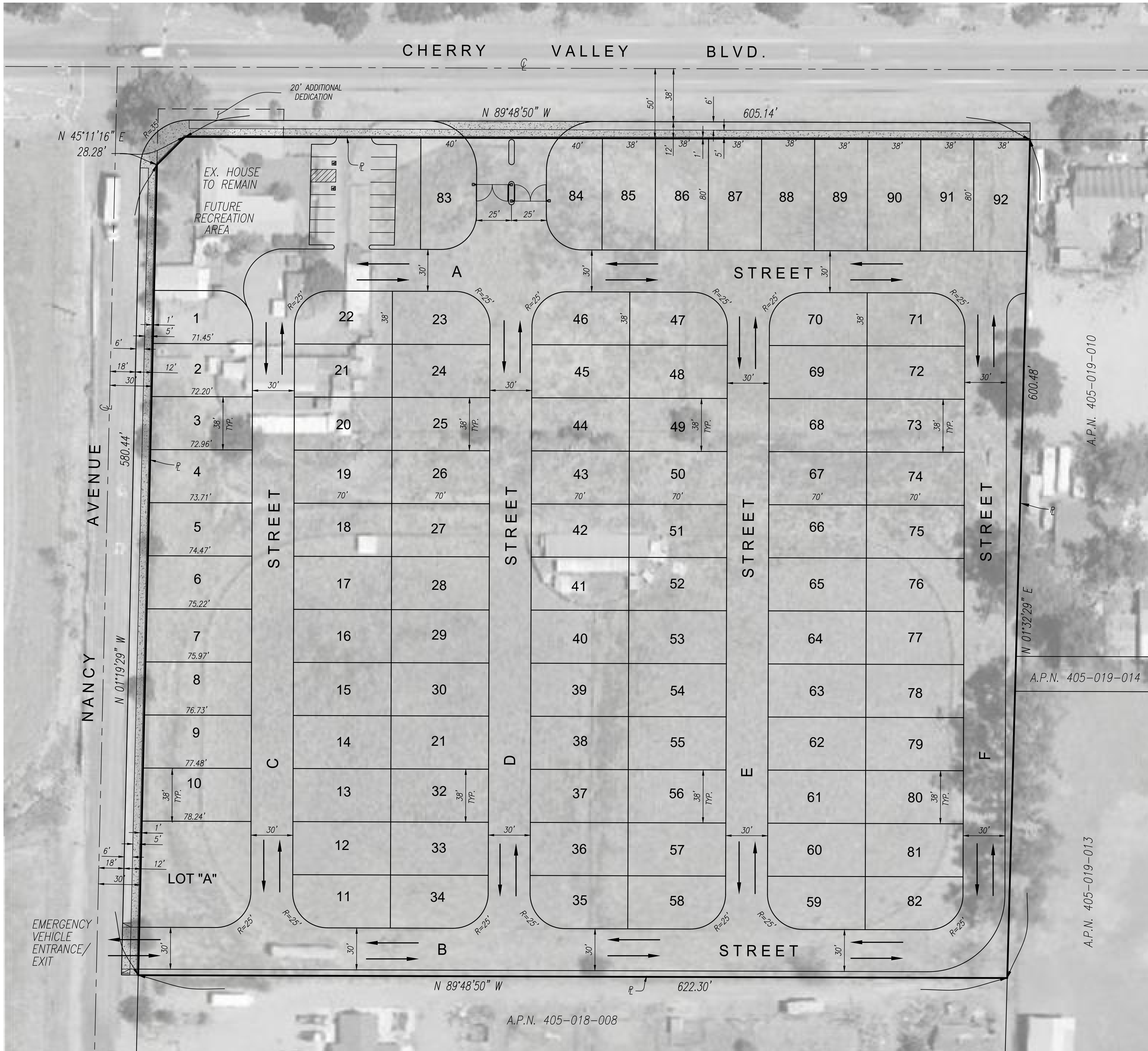

A.P.N. 405-019-010

N 01°32'29" E

A.P.N. 405-019-014

A.P.N. 405-019-013

A.P.N. 405-018-008



PREPARED BY:
ANDREASEN ENGINEERING, INC.
Civil Engineering • Land Surveying • Municipal Engineering
195 North Euclid Avenue, Suite 101, Upland, California 91786
(909) 623-1595 - www.aecivil.com



**COUNTY OF RIVERSIDE
PLANNING DEPARTMENT
STAFF REPORT**

Agenda Item No.

Director's Hearing: July 29, 2024

PROPOSED PROJECT

Case Number(s):	GPA240052 (Initiation Proceeding)	Applicant(s):	Dilip Sheth
Environmental:	Exempt		
Area Plan:	The Pass	Representative(s):	
Zoning Area/District:	Cherry Valley District		
Supervisory District:	Fifth District		
Project Planner:	Edward Lincoln		
Project APN(s):	405-180-006		
			John Hildebrand Planning Director

PROJECT DESCRIPTION AND LOCATION

The General Plan Amendment (GPA240052) is a proposal to amend the project site's Foundation Component from Rural Community (RC) to Community Development (CD) and amend its Land Use Designation from Very Low Density Residential (VLDR) to High Density Residential (HDR), on 1 parcel, totaling 9.44 gross acres.

The parcel is located north of Brookside Ave, east of Nancy Ave, south of Cherry Valley Blvd, and west of Virginia Ln.

PROJECT RECOMMENDATION

RECOMMENDATIONS:

THAT THE GENERAL PLAN AMENDMENT ADVISORY COMMITTEE MEMBERS TAKE THE FOLLOWING ACTION:

CONSIDER whether to recommend the initiation of **GENERAL PLAN AMENDMENT NO. 240052 (GPA240052)**.

PROJECT DATA

Land Use and Zoning:

Specific Plan:	N/A
Specific Plan Land Use:	N/A
Existing General Plan Foundation Component:	Rural Community (RC)
Proposed General Plan Foundation Component:	Community Development (CD)
Existing General Plan Land Use Designation:	Very Low Density Residential (VLDR)

Proposed General Plan Land Use Designation:	High Density Residential (HDR)
Policy / Overlay Area:	Cherry Valley Policy Area
Surrounding General Plan Land Uses	
North:	Very Low Density Residential (RC: VLDR)
East:	Very Low Density Residential (RC: VLDR)
South:	Very Low Density Residential (RC: VLDR)
West:	Agriculture (AG)
Existing Zoning Classification:	Agriculture (A-1-1)
Proposed Zoning Classification:	N/A
Surrounding Zoning Classifications	
North:	Agriculture (A-1-1)
East:	Agriculture (A-1-1)
South:	Agriculture (A-1-1)
West:	Agriculture (A-1-20)
Existing Use:	
Surrounding Uses	
North:	
East:	
South:	
West:	

Located Within:

City's Sphere of Influence:	No
Community Service Area ("CSA"):	No / Yes – Location
Special Flood Hazard Zone:	No / Yes – Location
Agricultural Preserve:	No
Liquefaction Area:	No / Yes – Location
Subsidence Area:	No / Yes – Location
Fault Zone:	Yes – County Fault Zone
Fire Zone:	No
Mount Palomar Observatory Lighting Zone:	No / Yes – Location
WRCMSHCP Criteria Cell:	No
CVMSHCP Conservation Boundary:	No
Stephens Kangaroo Rat ("SKR") Fee Area:	No / Yes – Location
Airport Influence Area ("AIA"):	No

Environmental Justice (“EJ”) Community | No

PROJECT LOCATION MAP



Figure 1: Project Location Map

PROJECT BACKGROUND AND ANALYSIS

Background

The proposed Foundation Component General Plan Amendment (FC-GPA) is an initiation procedure per the General Plan which occurs in eight (8) year cycles, most recently occurring in 2024. All property owners and applicants wanting to change their Foundation Components are required to submit their proposals for land use designation changes to the County of Riverside for consideration and possible initiation by the Board of Supervisors.

Further determination of zoning classifications, neighborhood compatibility, and other development factors or findings shall be made if the proposed FC-GPA (GPA240052) is initiated by the Board of Supervisors. Any initiated FC-GPA, by the Board of Supervisors, will require the submittal of an implementing project within six (6) months from initiation.

Applicant Proposal

FC-GPA240052 is a proposal to change the Foundation Component Land Use Designation from Rural Community: Very Low Density Residential (RC: VLDR) to Community Development: High Density Residential (CD: HDR). The parcel is located in the Cherry Valley Policy Area Policy area.

If FC-GPA240052 is approved by the Board of Supervisors, the applicant intends to apply for an implementing project consisting of a mobile home park containing 8 - 10 homes per acre.

Proposed Future Land Use

The proposed Community Development (CD) Foundation encompasses many underlying land use designations. The most intensive land use designation permitted within the CD Foundation is the Heavy Industrial (CD-HI) land use designation, which allows for more intense industrial activities that generate greater effects such as excessive noise, dust, and other nuisances.

The Proposed High Density Residential (CD-HDR) land use designation is intended to allow for single-family attached and detached residences. This includes townhouses, stacked flats, courtyard homes, patio homes, and zero lot line homes. The density range is 8-14 dwelling units per acre.

PUBLIC HEARING NOTIFICATION AND COMMUNITY OUTREACH

This project was advertised on the Riverside County Planning Department website. Additionally, public hearing notices in English and Spanish, pursuant to department policy and in accordance with the requirements of Ordinance 348, were mailed to property owners within 600 feet of the project site the General Plan Advisory Committee.



X comments were received to date. Comments indicated concerns/support for/about X.

ATTACHMENTS

- Exhibit A – Vicinity Maps**
- Exhibit B – Existing Land Use Designations**
- Exhibit C – Existing Zoning Classifications**
- Exhibit D – Noticing Radius and Labels**
- Exhibit E – Applicant’s Exhibits**
- Exhibit H – Public Comments**

RIVERSIDE COUNTY PLANNING DEPARTMENT

GPA240052

VICINITY/POLICY AREAS

Supervisor: YXSTIAN GUTIERREZ

Date: 2-11-2025

District: 5

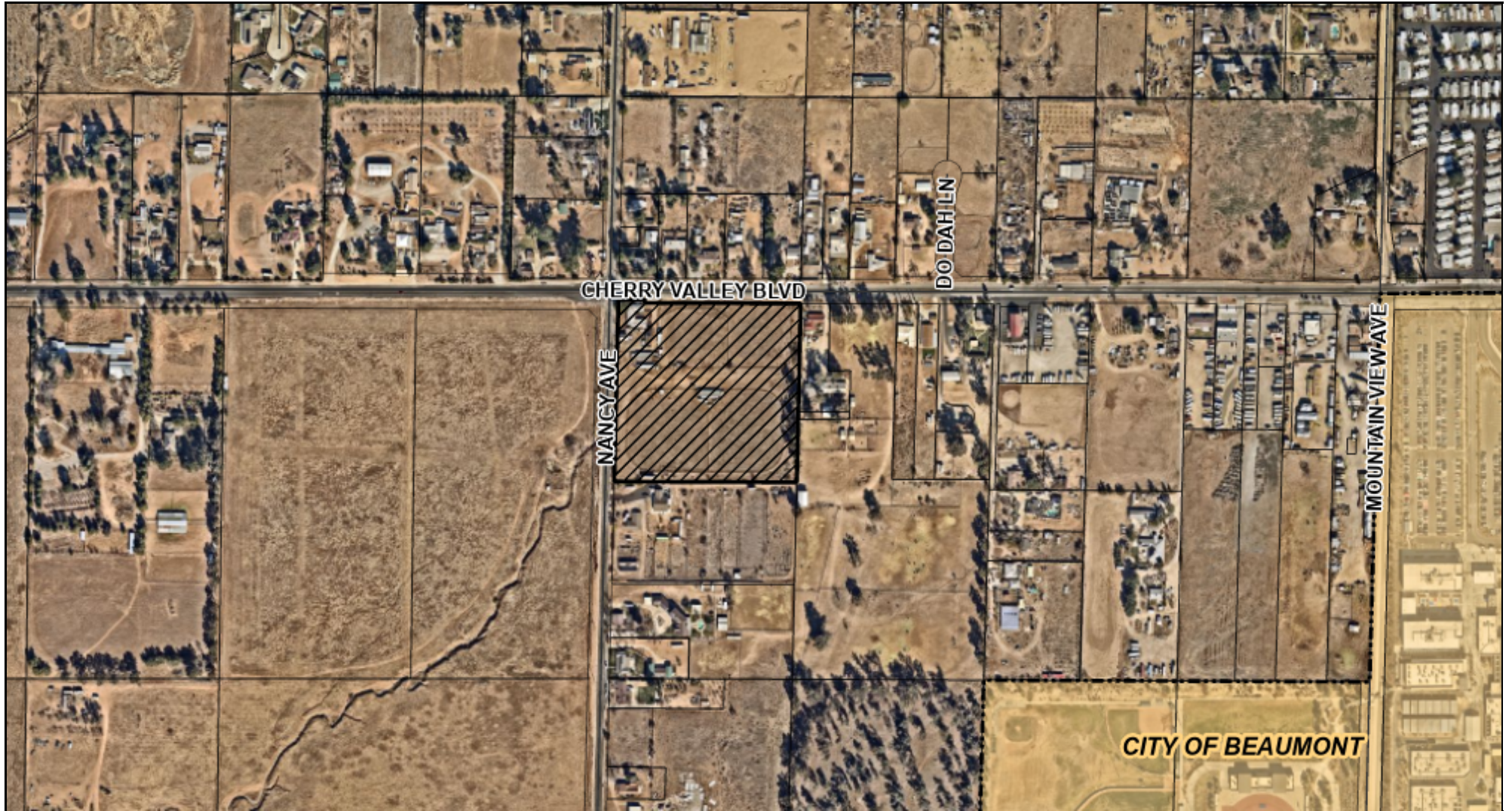

Zoning Area/District: CHERRY VALLEY

DISCLAIMER: On October 7, 2003, the County of Riverside adopted a new General Plan providing new land use designations for unincorporated Riverside County parcels. The new General Plan may contain different type of land use than is provided for under existing zoning. For further information, please contact the Riverside County Planning Department offices in Riverside at (951)955-3200 (Western County) or in Palm Desert at (760)863-8277 (Eastern County) or Website <http://planning.rctlma.org>

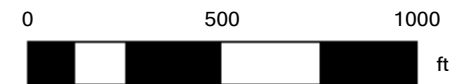

Foundation Component GPA Cycle Map

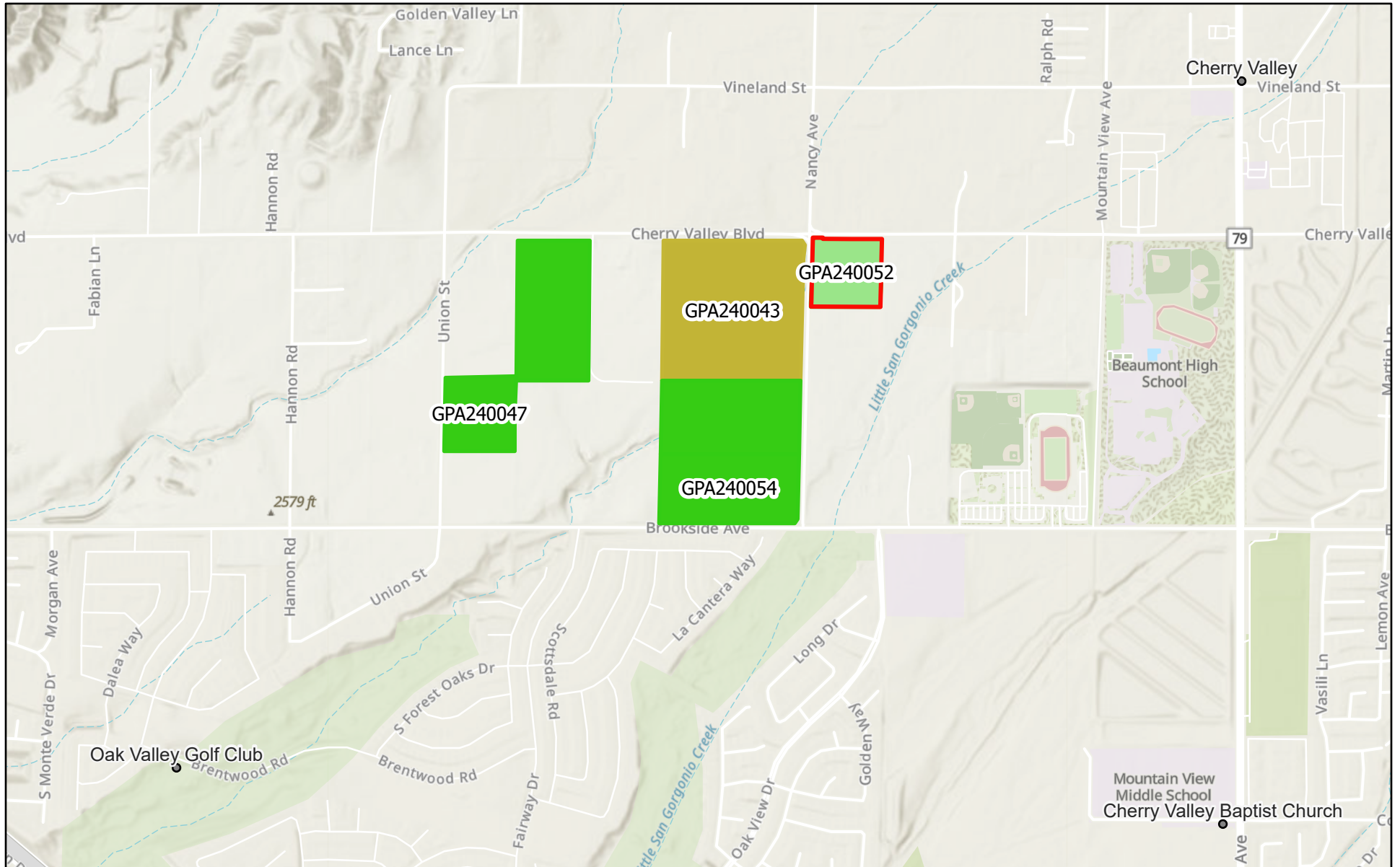

4/28/2025, 1:29:25 PM

 FGPA Web Map _Query result

 California Geographic Names Information System

FGPA Web Map

 Active

 On Hold

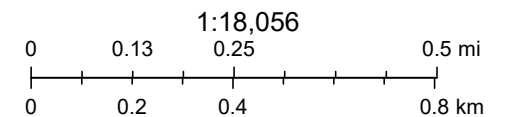

Esri, NASA, NGA, USGS, FEMA, Sources: Esri, TomTom, Garmin, FAO, NOAA, USGS, © OpenStreetMap contributors, and the GIS User Community

TLMA - Planning

RIVERSIDE COUNTY PLANNING DEPARTMENT

GPA240052

EXISTING GENERAL PLAN

Supervisor: YXSTIAN GUTIERREZ

Date: 2-13-2025

District: 5

Exhibit: 5

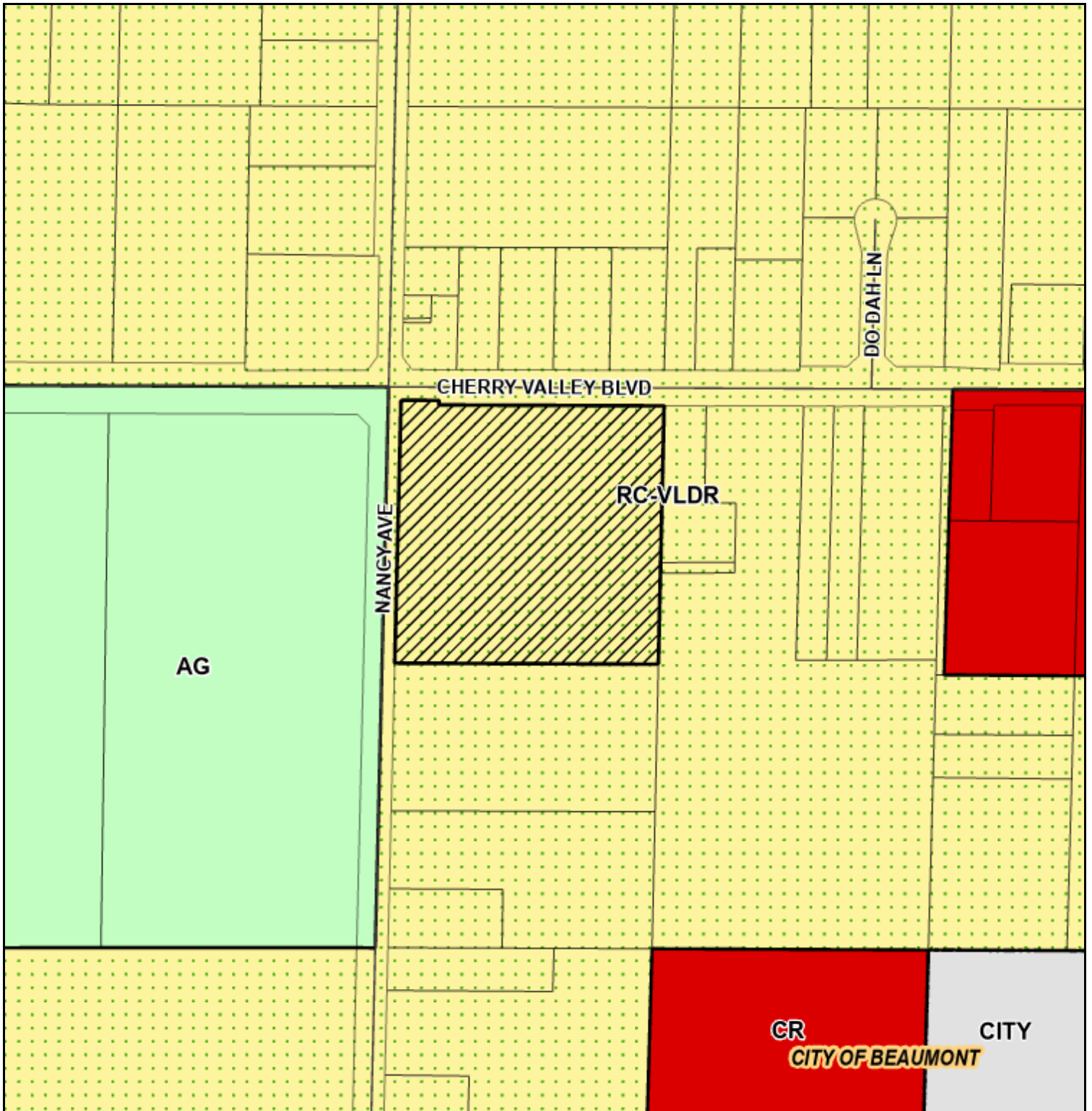

Zoning Area/District: CHERRY VALLEY

Author:

DISCLAIMER: On October 7, 2003, the County of Riverside adopted a new General Plan providing new land use designations for unincorporated Riverside County parcels. The new General Plan may contain different type of land use than is provided for under existing zoning. For further information, please contact the Riverside County Planning Department offices in Riverside at (951)955-3200 (Western County) or in Palm Desert at (760)863-8277 (Eastern County) or Website <http://planning.rctlma.org>

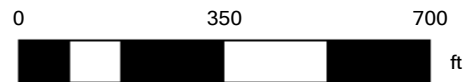

RIVERSIDE COUNTY PLANNING DEPARTMENT

GPA240052

EXISTING ZONING

Supervisor: YXSTIAN GUTIERREZ

Date: 2-13-2025

District: 5

Exhibit: 2

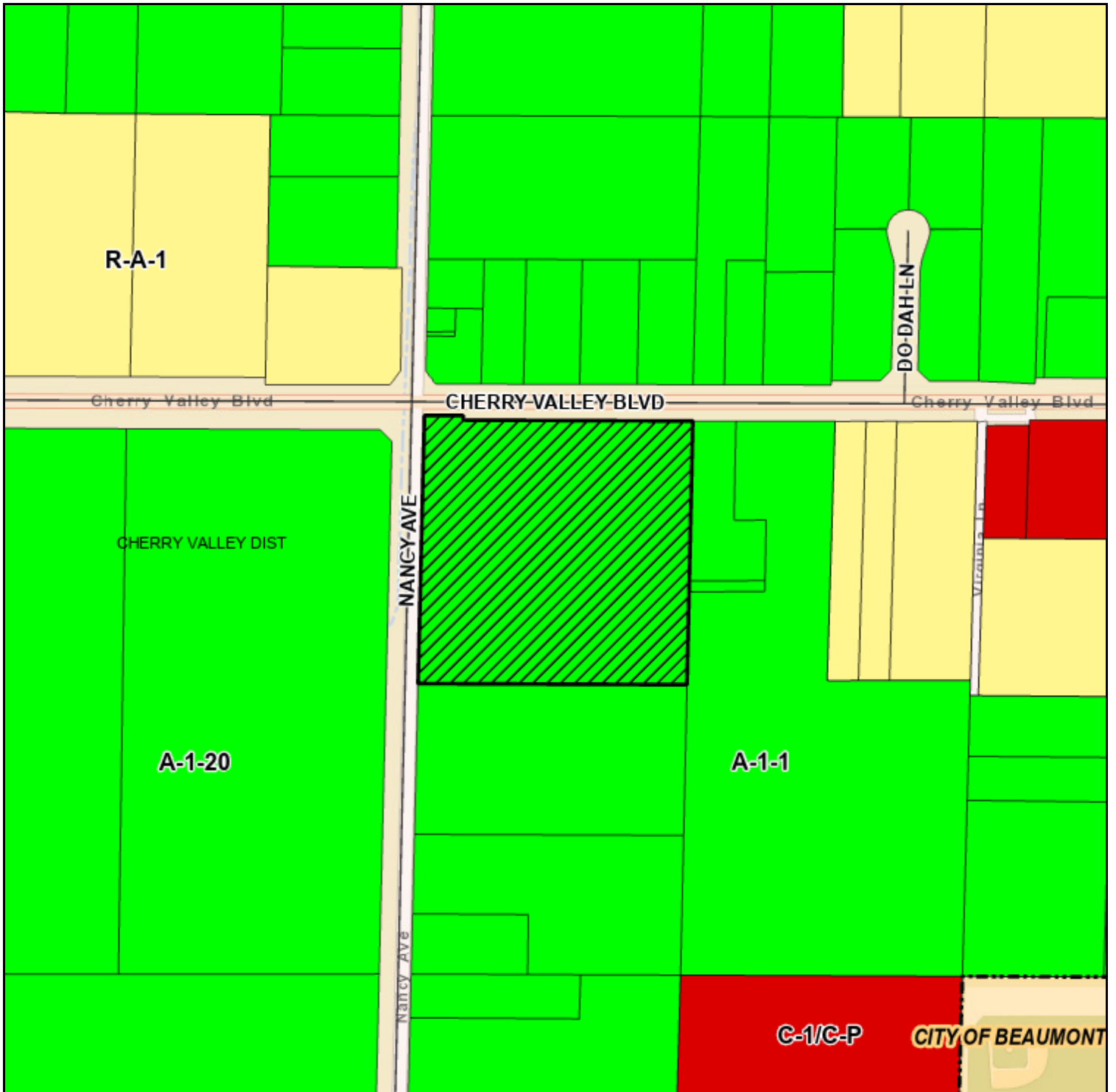

Zoning Area/District: CHERRY VALLEY

DISCLAIMER: On October 7, 2003, the County of Riverside adopted a new General Plan providing new land use designations for unincorporated Riverside County parcels. The new General Plan may contain different type of land use than is provided for under existing zoning. For further information, please contact the Riverside County Planning Department offices in Riverside at (951)955-3200 (Western County) or in Palm Desert at (760)863-8277 (Eastern County) or Website <http://planning.rctlma.org>

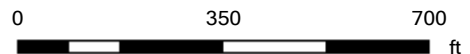



John E. Hildebrand
Planning Director

RIVERSIDE COUNTY

PLANNING DEPARTMENT

CERTIFICATION OF PUBLIC NOTICE

PROJECT NUMBER (FC-GPA240052)

Planning Case APN(s): 405-180-006

I, Edward Lincoln certify that on April 28, 2025, the attached property owners list was prepared pursuant to notification procedures in Subsection 1.7.A.3. of Ordinance 348. Attached list is a complete and true compilation of the owners of the subject property and all other property owners within 600 feet of the property involved.

I further certify that the information filed is true and correct to the best of my knowledge.

NAME: Edward Lincoln
TITLE: Associate Planner
ADDRESS: 4080 Lemon St 12th Fl., Riverside, CA 92501
PHONE: 951-955-8514
EMAIL: elincoln@rivco.org

SIGNATURE: *Edward Lincoln*

Riverside County GIS Mailing Labels

GPA240052

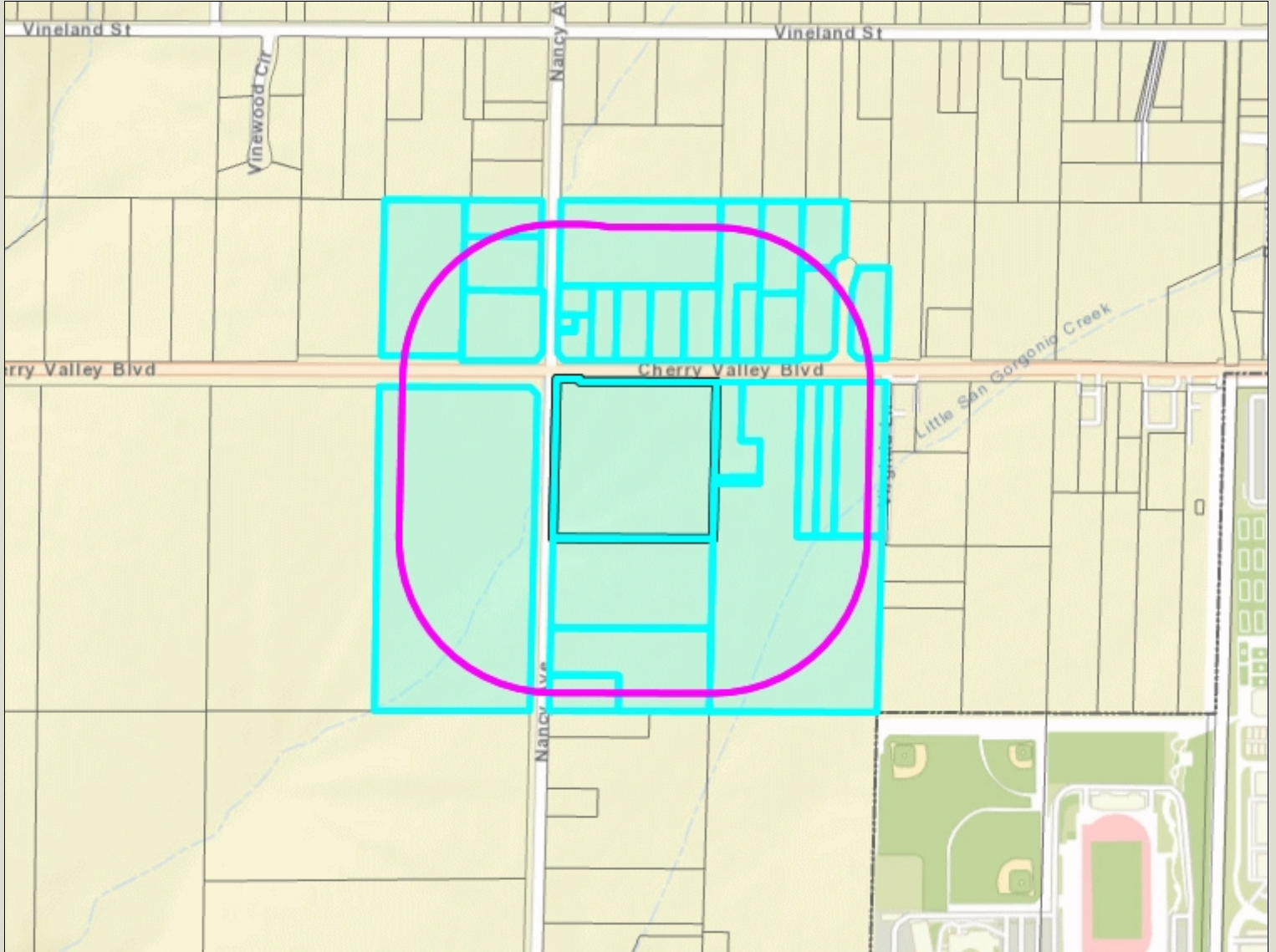

Legend

-  County Boundary
-  Cities
-  Parcels
-  World Street Map

Notes



0 752 1,505 Feet

IMPORTANT Maps and data are to be used for reference purposes only. Map features are approximate, and are not necessarily accurate to surveying or engineering standards. The County of Riverside makes no warranty or guarantee as to the content (the source is often third party), accuracy, timeliness, or completeness of any of the data provided, and assumes no legal responsibility for the information contained on this map. Any use of this product with respect to accuracy and precision shall be the sole responsibility of the user.

REPORT PRINTED ON... 2/13/2025 9:24:02 AM

© Riverside County RCIT

405110001
WILLIAM K. LATTIN
9824 JONATHAN AVE
CHERRY VALLEY CA 92223

405110002
WILLIAM M. SIMPSON
40666 DUTTON
BEAUMONT CA 92223

405110012
GRACIELA ESTRADA
38656 CHERRY VALLEY BLV
BEAUMONT CA 92223

405110017
CHRISTOPHER LINDEN ASHTON
38648 CHERRY VALLEY BLVD
BEAUMONT CA 92223

405110018
JOSE PEREZ
38610 CHERRY VALLEY BLVD
BEAUMONT CA 92223

405110019
DARREN SURIO CASTILLO
38656 CHERRY VALLEY BLVD
BEAUMONT CA 92223

405110020
CURTIS BURHOP
38620 CHERRY VALLEY BLVD
BEAMO NT 92223

405110021
CLAUDIA JEAN NEWMAN
10498 NANCY AVE
BEAUMONT CA 92223

405110022
JOSHUA J. SHELLEY
38678 CHERRY VALLEY BLVD
CHERRY VALLEY CA 92223

405110025
EDDY S. AYALA
38634 CHERRY VALLEY BLVD
BEAUMONT CA 92223

405110026
WILLIAM M. SIMPSON
245 N LITCHFIELD RD 142
GOODYEAR AZ 85338

405110028
MOHAMMAD ASLAM
13088 SOUTH LN
REDLANDS CA 92373

405110030
DAN L. MARVIN
38690 CHERRY VALLEY BLVD
BEAUMONT CA 92223

405170008
DARREN BONETTI
10427 NANCY AVE
BEAUMONT CA 92223

405170009
APPA INV
11134 DAYLILLY ST
FONTANA CA 92337

405170012
JOHN L. KERN
38456 CHERRY VALLEY BLVD
BEAUMONT CA 92223

405170014
HOUSE OF DECISION OPPORTUNITY
38416 CHERRY VALLEY BLVD
CHERRY VALLEY CA 92223

405180003
KRISTINA M. VANDERBRUG
P O BOX 590
BEAUMONT CA 92223

405180004
RONDA L. DINKINS
10756 NANCY AVE
CHERRY VALLEY CA 92223

405180006
OM JOSHUA
904 SILVER SPUR NO 479
ROLLING HILLS CA 90274

405180008
ATENCIO FAMILY TRUST DATED
04/10/2023
10664 NANCY AVE
BEAUMONT CA 92223

405190006
FLOREN ERIK DAVID REVOCABLE
TRUST
38745 CHERRY VALLEY BLVD
BEAUMONT CA 92223

405190007
IRMA NAVA
48712 DESERT FLOWER DR
PALM DESERT CA 92260

405190008
ELIAS BALDERRAMA
38705 CHERRY VALLEY BLVD
CHERRY VALLEY CA 92223

405190010
OSTER MARK A
38649 CHERRY VALLEY BLV
BEAUMONT CA 92223

405190014
MARK A. OSTER
38649 CHERRY VALLEY BLVD
CHERRY VALLEY CA 92223

405250007
CHERRY VALLEY PARTNERS
32036 LIVE OAK CANYON RD
REDLANDS CA 92373

CHERRY VALLEY ESTATES COUNTY OF RIVERSIDE SITE PLAN

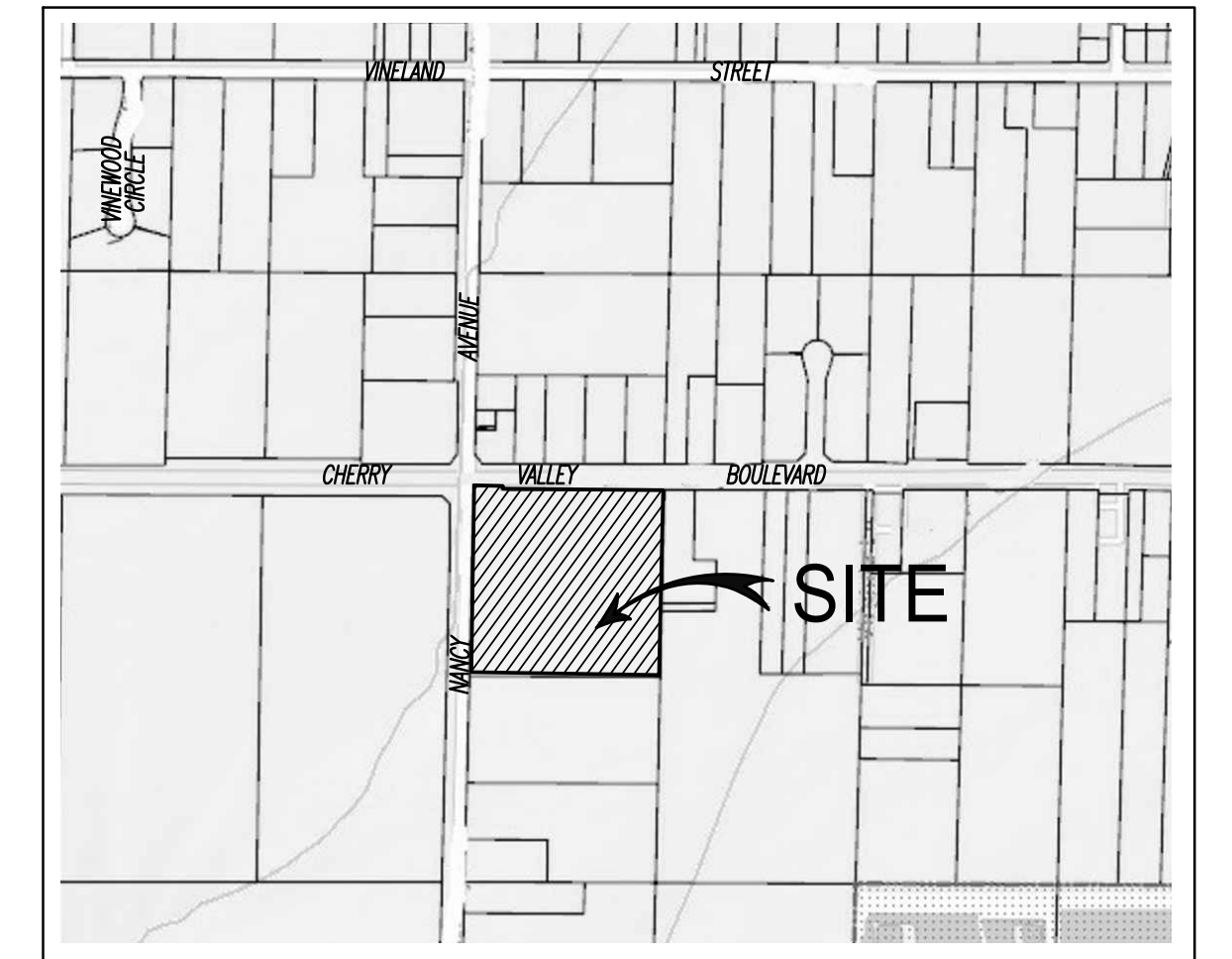

VICINITY MAP
N.T.S.

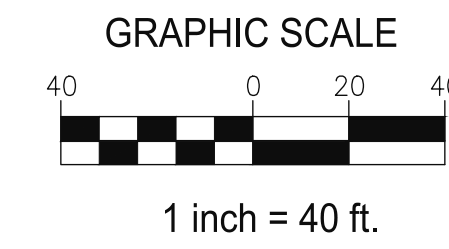
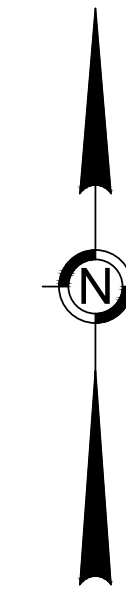

LEGAL DESCRIPTION:

THE NORTH HALF OF LOT 4 IN BLOCK 9 OF CHERRY VALLEY WEST ADDITION, IN THE COUNTY OF RIVERSIDE, STATE OF CALIFORNIA, AS SHOWN BY MAP ON FILE IN BOOK 6, PAGE 36 OF MAPS, RECORDS OF SAID COUNTY.

EXCEPTING THEREFROM THE SOUTH 25 FEET OF THE NORTH HALF OF SAID LOT 4.

ASSESSOR'S PARCEL NUMBER:

405-108-006

OWNER:

OM JOSHUA LLP
904 SILVER SPUR #479
ROLLING HILLS ESTATES, CA 90274

NOTES:

LOT "A" IS FOR R.V. PARKING AND UNDERGROUND INFILTRATION RETENTION AREA.

LEGEND

- BOUNDARY OF PROPERTY
- PROPOSED LOT LINE
- DIRECTION OF TRAVEL

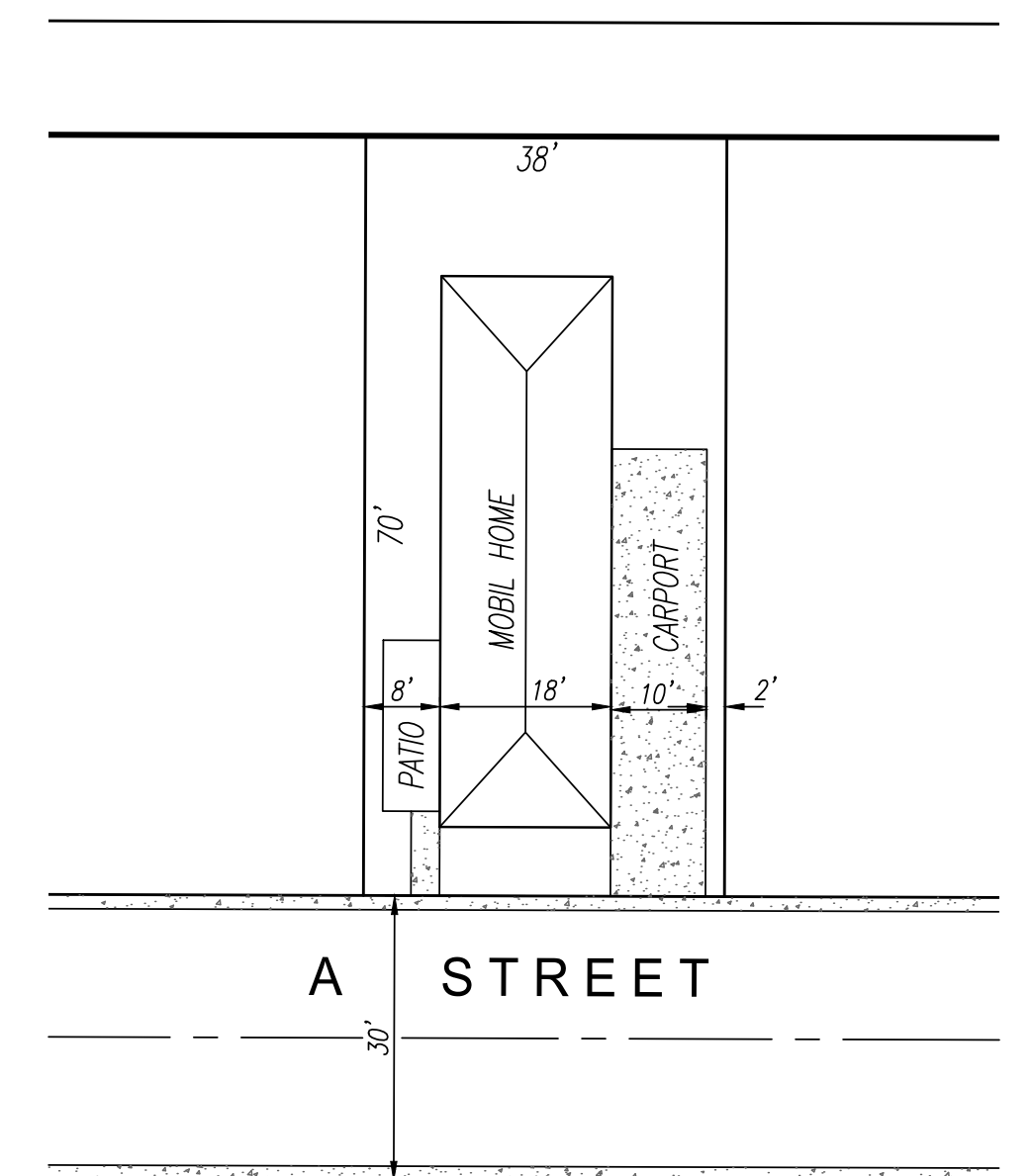

TYPICAL LOT LAYOUT

SCALE: 1"=20'

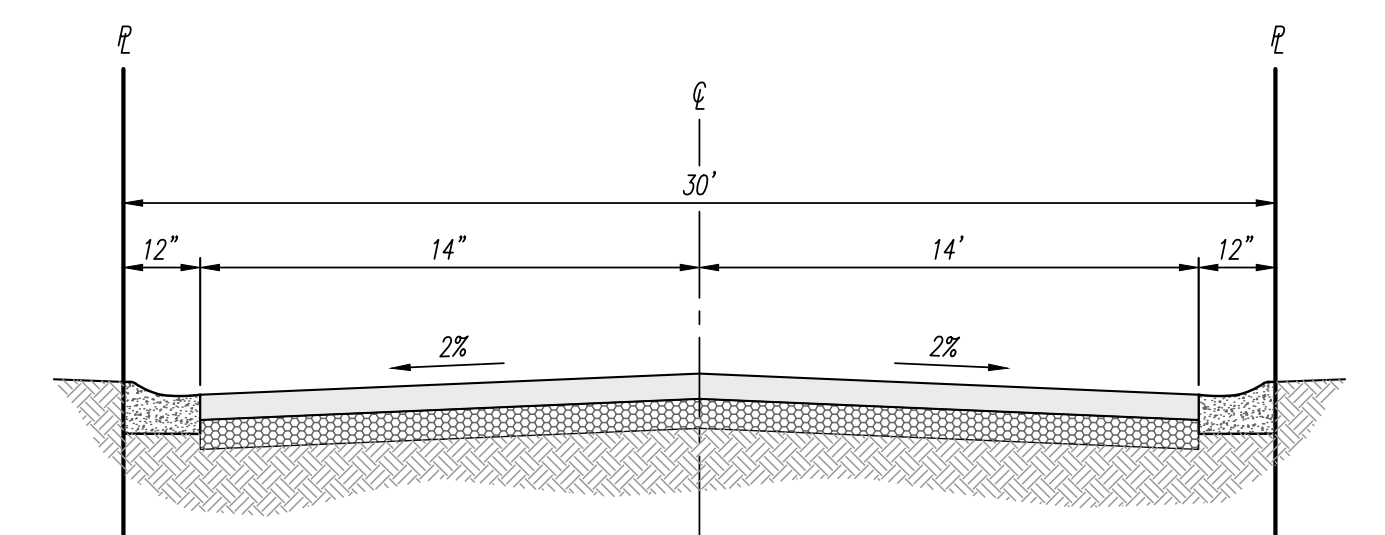

TYPICAL PRIVATE STREET

NOT TO SCALE

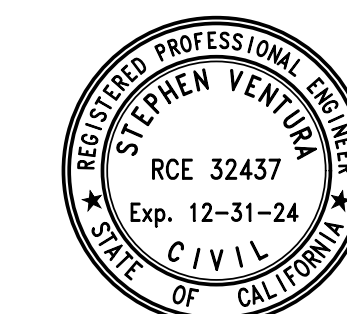
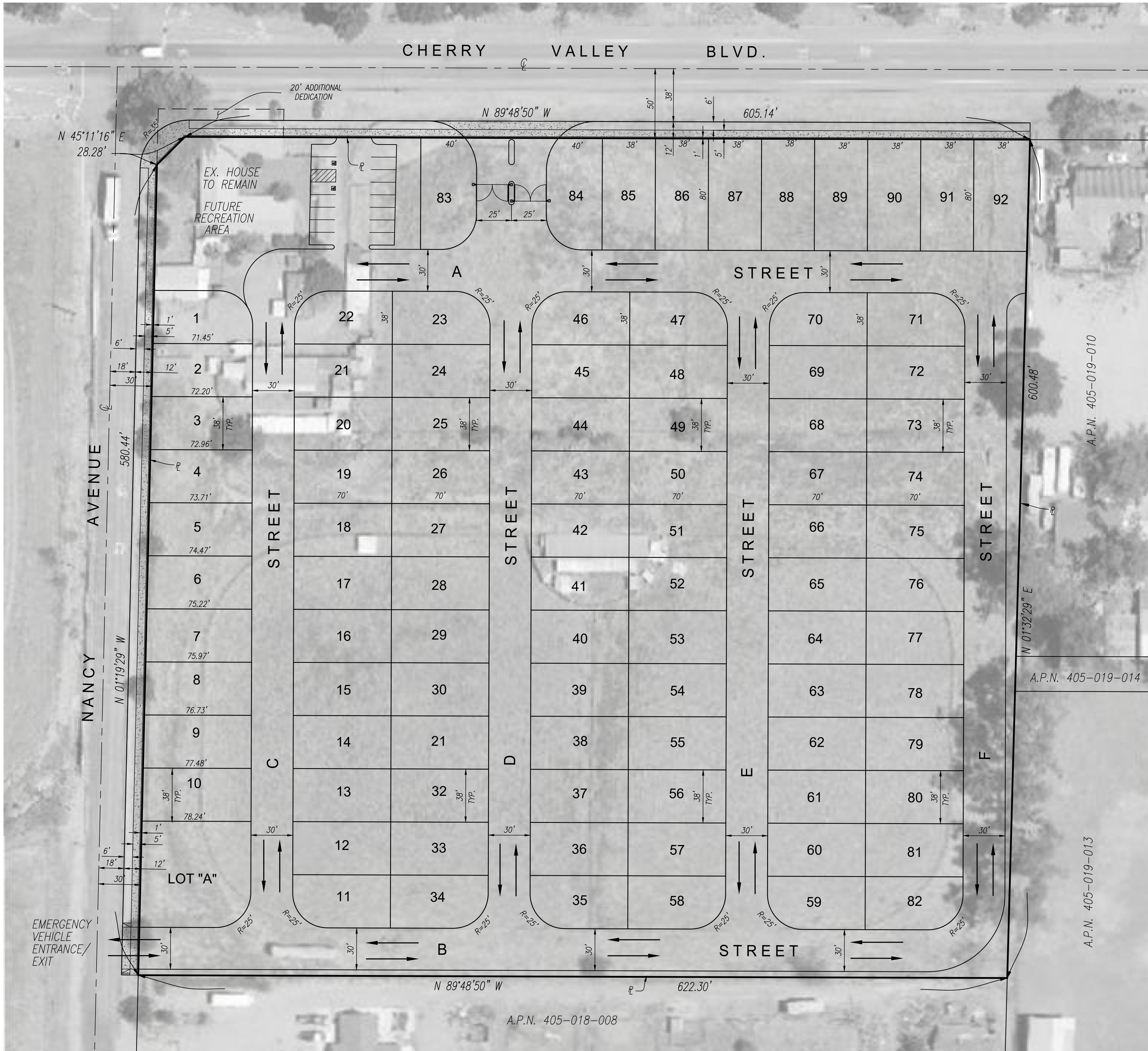

PREPARED BY:
ANDREASEN ENGINEERING, INC.
Civil Engineering • Land Surveying • Municipal Engineering
195 North Euclid Avenue, Suite 101, Upland, California 91786
(909) 623-1595 - www.aecivil.com

From: [Carmen Orozco](#)
To: [Lincoln, Edward](#)
Subject: Community Planning 240052(GPA240052)
Date: Monday, March 10, 2025 9:20:05 AM

CAUTION: This email originated externally from the **Riverside County** email system. **DO NOT** click links or open attachments unless you recognize the sender and know the content is safe.

Hello, my name is Carmen and will not be able to attend the meeting today but wanted to know if there is a way for me to hear in the meeting like a zoom link or something. I oppose this, as my family and I moved here for the purpose of living in a rural area where we are able to raise animals (chickens, goats).

Thank you

Callie Atencio
10664 Nancy Avenue
Cherry Valley, CA 92223
CallieAtencio@gmail.com
(909) 838-2579

March 7, 2025

Riverside County Planning Department
Attn: Edward Lincoln
P.O. Box 1409
Riverside, CA 92509-1409

To whom it may concern,

I hope this letter finds you well. I am writing to formally object to the initiation of GPA240052 to change the General Plan Foundation Component of one parcel from Rural Community: Very Low Density Residential to Community Development High Density Residential.

As a resident of this community, I have serious concerns regarding the long-term impacts of this change on our community and overall quality of life. I would like to outline my primary objections:

1. **Increased Traffic and Infrastructure Strain:** The proposed zoning change would likely lead to a higher density of housing, which could result in more vehicles on already overburdened roads. Local infrastructure, including public services such as schools, water, and emergency services, may not be able to accommodate this increased demand. This could lead to reduced accessibility, longer commute times, and potential safety concerns for the current residents.
2. **Loss of Rural Character and Heritage:** One of the core reasons many of us chose to live in this area is the tranquil, rural atmosphere it provides. A transition to high-density residential development could fundamentally alter the character of the community and diminish the appeal of the area for those seeking the peaceful, rural lifestyle that Cherry Valley has always provided for its citizens. High density housing should remain in the communities of Beaumont and Banning, which have a greater need for it.
3. **Property Value Impact:** A zoning change to allow for increased residential development may lower the property values of existing homes in the surrounding area. This could be detrimental to property owners who have invested in the rural character of the neighborhood and chosen this area for its unique characteristics. I feel that the owner of the property could develop within the zoning requirements of Cherry Valley and still

receive a reasonable profit on the investment.

I respectfully ask that you reconsider this zoning change and take into account the concerns of those who will be directly impacted. I believe it is essential to preserve the integrity and character of our rural community while also considering future growth in a responsible manner that respects the needs of existing residents.

Thank you for your attention to this important matter. I hope you take mine and the community's concerns into serious consideration as you make your decision.

Sincerely,
Callie Atencio

From: [Michael Cary](#)
To: [Lincoln, Edward](#)
Subject: Opposition to General Plan Amendment 240052 – Cherry Valley
Date: Thursday, March 6, 2025 10:16:27 PM

CAUTION: This email originated externally from the Riverside County email system. DO NOT click links or open attachments unless you recognize the sender and know the content is safe.

Dear Planning Official Edward Lincoln,

I am writing to formally voice my strong opposition to General Plan Amendment 240052, which proposes changing the land use of a rural property in Cherry Valley, Riverside County, California, to allow for high-density housing. As a resident of this community, I am deeply concerned about the irreversible damage this development would inflict on our rural way of life and the strain it would place on our already overburdened resources and infrastructure.

Cherry Valley is a haven of quiet, country living—a deliberate choice for those of us who sought to escape the congestion and pace of city life. Approving high-density housing would destroy the very character that defines this area. Our infrastructure is simply not equipped to handle such a drastic change. Water resources are scarce, our schools are already overcrowded, and our roads—both surface streets and freeway access—cannot sustain additional pressure. The freeway interchange at I-10 and Cherry Valley Blvd. is already a nightmare due to the high number of homes built in nearby Calimesa, clogging traffic daily. Worse still, the warehouses constructed in the area—despite strong community opposition—haven't even begun operating their trucks, which will undoubtedly worsen this congestion. The I-10 and our local surface streets are not suited for this level of traffic, and piling on more residents from high-density housing would push these systems past their breaking point.

I am also disheartened by the impression that this amendment caters to the financial interests of a property owner rather than the voices of the citizens who call Cherry Valley home. When did our government shift from serving its people to prioritizing those with money? I urge you to listen to the community and reject this amendment to preserve the rural integrity of Cherry Valley.

I regret that I am unable to attend the public comment meeting on March 10, 2025, due to work obligations. Please consider this email as my official public comment for the record and ensure it is included in the decision-making process for General Plan Amendment 240052. I would appreciate a response confirming that my opposition has been noted and will be considered.

Thank you for your attention to this critical matter.

Sincerely,

Michael Cary
39723 Orchard St., Cherry Valley
760-887-4569

Sent from my iPhone

From: ryanwebb@gmx.com
To: [Lincoln, Edward](#)
Subject: Request for Denial of General Plan Amendment GPA 240052
Date: Sunday, March 9, 2025 7:47:55 PM

CAUTION: This email originated externally from the **Riverside County** email system. **DO NOT** click links or open attachments unless you recognize the sender and know the content is safe.

Good afternoon Riverside County General Plan Advisory Committee,

My name is Ryan Webb, and my family and I are requesting you deny the proposed amendment to the General Plan Foundation Component from Rural Community: Very Low Density Residential to Community Development: High Density Residential on APN: 405-180-006 in Cherry Valley. My family moved from Yucaipa to Cherry Valley because we wanted to show our children a different kind of life. We wanted them to learn how to care for animals, to work the land, to grow food, to drive a tractor, and to slow down in today's technology age. Since coming to Cherry Valley, we have rescued horses, goats, chickens, and dogs and our boys have learned so much since we moved here in 2023. We love the community and highly desire to preserve the way of life that many of the residents cherish. The charm associated with Cherry Valley is its unique sprawling landscape as opposed to the landscapes of rows and rows of homes packed tightly together that is seen in surrounding neighborhoods. We are asking to keep Cherry Valley as it is designed in the existing General Plan. We respect the need for high-density and low-income homes, we simply ask that they are placed in areas where they were originally designed to fit instead of uprooting the character of an existing community.

Additionally, the traffic infrastructure in Cherry Valley is remarkably inadequate to handle the existing traffic on Cherry Valley Blvd and surrounding streets. Traffic backs up for several blocks in both directions from the 10 freeway in the morning and evening. The off-ramp at Cherry Valley Blvd was recently renovated, however the traffic is worse than before the renovation. This traffic will only worsen once the two large warehouses are opened, and shipping traffic is interjected into existing traffic patterns. If this zoning change is approved there will be several hundred additional cars using the same inadequate roads and causing even more traffic congestion.

We are not opposed to the addition of homes, but respectfully request this proposed zoning change is denied, and projects that coincide with the existing zoning regulations are considered.

Thank you for your time.

Ryan Webb

From: [Lacey Webb](#)
To: [Lincoln, Edward](#)
Subject: Response for 3/10/25 Meeting
Date: Sunday, March 9, 2025 8:41:29 PM

CAUTION: This email originated externally from the Riverside County email system. DO NOT click links or open attachments unless you recognize the sender and know the content is safe.

Dear Mr. Lincoln,

My name is Lacey Webb and I currently reside in Cherry Valley, CA with my family. We recently purchased our home (2023), paying more than we wanted to (and probably more than the house was worth), gambling with high interest rates, etc. because we desired to raise our boys out of the city.

Additionally, we founded a non-profit 501c3 Farm Animal Sanctuary on our property. It is a special place where people and animals can find peace and healing. Our cross street is Cherry Valley Blvd.; I can't imagine more traffic than we already experience. Our infrastructure can't handle more traffic/houses to that degree. I know this may not be a concern to most, but it would negatively impact our animals, particularly the horses, who come to us to retire peacefully. Additional stress equals very substantial vet bills for us. It also takes away from the serenity people feel when coming to our property to find respite.

The rural landscape of Cherry Valley is what draws people to it; the family produce stands, animals, grazing cows. It's something that people travel to experience for a day... and the very thing that will be lost with the rezoning and addition of high density housing. This very lot in question is where my boys and I look for the cattle and thank God for the breath of fresh air and open space. This is a rare find in California and a very strange place to put high density housing, figuring we don't even have a grocery store, laundromat, or many restaurants. We have one small gas station. Many of our neighbors on well water have experienced issues with the water table. What would high density housing do to our water supply?? Our family and animals depend on it.

I am humbly asking you to deny this rezoning request!! We are not able to move our non-profit if the current zoning is changed. We moved to Cherry Valley because of the current zoning, please protect this little gem with us.

Respectfully,

Lacey Webb

Sent from my iPhone

From: socalsurfer092@aol.com
To: [Lincoln, Edward](#)
Subject: rezoning to high density applicant aaron cooke
Date: Sunday, March 9, 2025 7:43:26 PM

CAUTION: This email originated externally from the **Riverside County** email system. **DO NOT** click links or open attachments unless you recognize the sender and know the content is safe.

Mr. Lincoln,

I have been a resident of Cherry Valley since 2010. I, like many other residents, purchased my home in Cherry Valley because of the relaxing, quiet, rural, low-density, serene residential/agricultural environment. High-density, low income housing will negatively change the character of Cherry Valley forever. There is plenty of wide open, undeveloped land, further on down the freeway where high-density low-income communities can be developed. There is no need to overcrowd Cherry Valley and destroy its charm and character.

Over the years, my work commute has increased from 40 minutes to 90 minutes each way! Our freeways need more lanes added to accommodate the "existing" increase in traffic created by new housing tracts that have already been built. City streets are getting crowded and have not kept up with population growth either.

A developer's greed should not be allowed to negatively impact our community. Request for rezoning by Aaron Cooke (or any other applicant), should not be granted at the detriment of current residents and their use and enjoyment of their property and the zoning it was purchased with. Develop property elsewhere and leave rural low-density rural Cherry Valley as it is.

Sincerely,

Stuart Baxter

From: [Sharon Cartter- Crawford](#)
To: [Lincoln, Edward](#)
Subject: Riverside County Planning Department Attn: Edward Lincoln P.O. Box 1409, Riverside, Ca, 92502-1409
Date: Monday, March 10, 2025 2:40:13 PM

CAUTION: This email originated externally from the **Riverside County** email system. **DO NOT** click links or open attachments unless you recognize the sender and know the content is safe.

Dear Mr Edward Lincoln,

We here in Cherry Valley and Beaumont oppose this development and change of zoning request. The last developer that tried this was denied and it was a waste of time for both parties including the City.

You'll have many residents at your meeting that opposed this kind of rezone restructuring.

This is a rural community and it remains to stay that way. No more multi-structure development housing, commercial or industrial building or business....

The Community and Residence of Cherry Valley and Beaumont, opposed these types of changes to zoning. And they will be at each and every venue / meeting that tries to pass new zoning.

Here's a thought, Rural housing with horse property would be the appropriate building choice. R-R, A-1, A-2 and W-1 Zones: The grazing of horses, not to exceed five animals per acre of all the land available; provided however, the systematic rotation of animals with more than five animals per acre is permitted so long as the total number of permitted animals is not exceeded.

This will Never Pass!

Sincerely,

Sharon Crawford

A Concerned Citizen of Cherry Valley, Riverside County California 92223

From: [Kim Morgan](#)
To: [Lincoln, Edward](#)
Subject: Rezoning in Cherry Valley
Date: Sunday, March 9, 2025 9:24:22 PM

CAUTION: This email originated externally from the **Riverside County** email system. **DO NOT** click links or open attachments unless you recognize the sender and know the content is safe.

Dear Mr. Lincoln,

I am writing to STRONGLY protest the rezoning of Cherry Valley. I have lived in Cherry Valley for 3 years and have experienced an amazing increase in traffic in the past year and a half trying to get my grandson to school in the morning. Highway 10 west is at a standstill every single morning with a huge number of drivers diverting from the highway route down Cherry Valley Blvd to Calimesa Blvd or Beaumont Ave. At the same time Brookside is inundated with the high school traffic. I can't imagine what the extra traffic will be like Or how anyone will be able to navigate this area, not to mention the warehouse traffic when that finally starts happening. Cherry Valley is a rural area that people chose for this reason . When we purchased our home it was because of the reassurance of the set zoning rules already in place. I feel it is not in the best interest of the land or the people who chose to live here to allow a housing development to disrupt this area. There are many considerable factors that need very close scrutiny before making such a drastic decision for this area. I feel strongly that this is not a good fit for Cherry Valley. Thank you for your consideration of my comments

Sincerely

Kim Morgan

Get [Outlook for iOS](#)



**COUNTY OF RIVERSIDE
PLANNING DEPARTMENT
STAFF REPORT**

Agenda Item No.

4.1

(ID # 28570)

MEETING DATE:

Wednesday, September 03, 2025

SUBJECT: INITIATION OF FOUNDATION COMPONENT GENERAL PLAN AMENDMENT NO. 240052 (GPA240052) – REQUEST: The applicant requests that the County of Riverside consider whether to recommend the initiation of GPA240052 to change the General Plan Foundation Component of one (1) parcel from Rural Community: Very Low Density Residential (RC:VLDR) to Community Development: Low Density Residential (CD:LDR), to allow for submittal of an application for sixteen (16) custom homes on a half-acre (0.5) lot. Additional development applications and review by the County to confirm that the overall project complies with applicable standards, policies, findings, and other requirements will be required if the proposed GPA240052 is initiated by the Board of Supervisors. – Fifth Supervisorial District - Cherry Valley Zoning District – The Pass Area Plan - Owner: Dilip Sheth – Existing Zoning: A-1 (Light Agriculture) – Existing Land Use: Very Low Density Residential (RC:VLDR) – Location: North of Brookside Avenue, east of Nancy Avenue, south of Cherry Valley Boulevard, and west of Virginia Lane – APN(s): 405-180-006 – 9.44 Gross Acres – Project Planner: Edward Lincoln at (951) 955-8514, or email at elincoln@rivco.org.

PROPOSED PROJECT

Case Number(s):	GPA240052	
Environmental Type:	Exemption	
Area Plan No.	The Pass	
Zoning Area/District:	Cherry Valley District	
Supervisorial District:	Fifth District	
Project Planner:	Edward Lincoln	
Project APN(s):	405-180-006	
Continued From:		

PROJECT DESCRIPTION AND LOCATION

The General Plan Amendment (GPA240052) is a proposal to amend the project site's Foundation Component from Rural Community (RC) to Community Development (CD) and amend its Land Use Designation from Very Low Density Residential (RC: VLDR) to Low Density Residential (CD: LDR), on one (1) parcel, totaling 9.44 gross acres.

The parcel is located north of Brookside Ave, east of Nancy Ave, south of Cherry Valley Blvd, and west of Virginia Ln.

**COUNTY OF RIVERSIDE PLANNING DEPARTMENT
STAFF REPORT**

PROJECT RECOMMENDATION

STAFF RECOMMENDATIONS:

THAT THE PLANNING COMMISSION TAKE THE FOLLOWING ACTION:

CONSIDER whether to recommend the initiation of GENERAL PLAN AMENDMENT NO. 240052 (GPA240052).

PROJECT DATA

Land Use and Zoning:

Specific Plan:	N/A
Specific Plan Land Use:	N/A
Existing General Plan Foundation Component:	Rural Community (RC)
Proposed General Plan Foundation Component:	Community Development (CD)
Existing General Plan Land Use Designation:	Very Low Density Residential (RC: VLDR)
Proposed General Plan Land Use Designation:	Low Density Residential (CD: LDR)
Policy / Overlay Area:	Cherry Valley Policy Area
Surrounding General Plan Land Uses	
North:	Very Low Density Residential (RC: VLDR)
East:	Very Low Density Residential (RC: VLDR)
South:	Very Low Density Residential (RC: VLDR)
West:	Agriculture (AG: AG)
Existing Zoning Classification:	A-1 (Light Agriculture)
Proposed Zoning Classification:	N/A
Surrounding Zoning Classifications	
North:	A-1 (Light Agriculture)
East:	A-1 (Light Agriculture)
South:	A-1 (Light Agriculture)
West:	A-1 (Light Agriculture)
Existing Use:	Horse grazing / Open space
Surrounding Uses	

**COUNTY OF RIVERSIDE PLANNING DEPARTMENT
STAFF REPORT**

	North:	Family Residences
	South:	Residence and Farmland
	East:	Residence and Farmland
	West:	Open Space

Located Within:

City's Sphere of Influence:	No
Community Service Area ("CSA"):	Yes – 152 and 27
Special Flood Hazard Zone:	Yes – Verify Outside floodplain
Agricultural Preserve:	No
Liquefaction Area:	Yes – Low
Subsidence Area:	Yes – Susceptible
Fault Zone:	Yes – County Fault Zone
Fire Zone:	No
Mount Palomar Observatory Lighting Zone:	No / Yes – Location
WRCMSHCP Criteria Cell:	No
CVMSHCP Conservation Boundary:	No
Stephens Kangaroo Rat ("SKR") Fee Area:	No
Airport Influence Area ("AIA"):	No
Environmental Justice ("EJ") Community	No

PROJECT LOCATION MAP

COUNTY OF RIVERSIDE PLANNING DEPARTMENT
STAFF REPORT

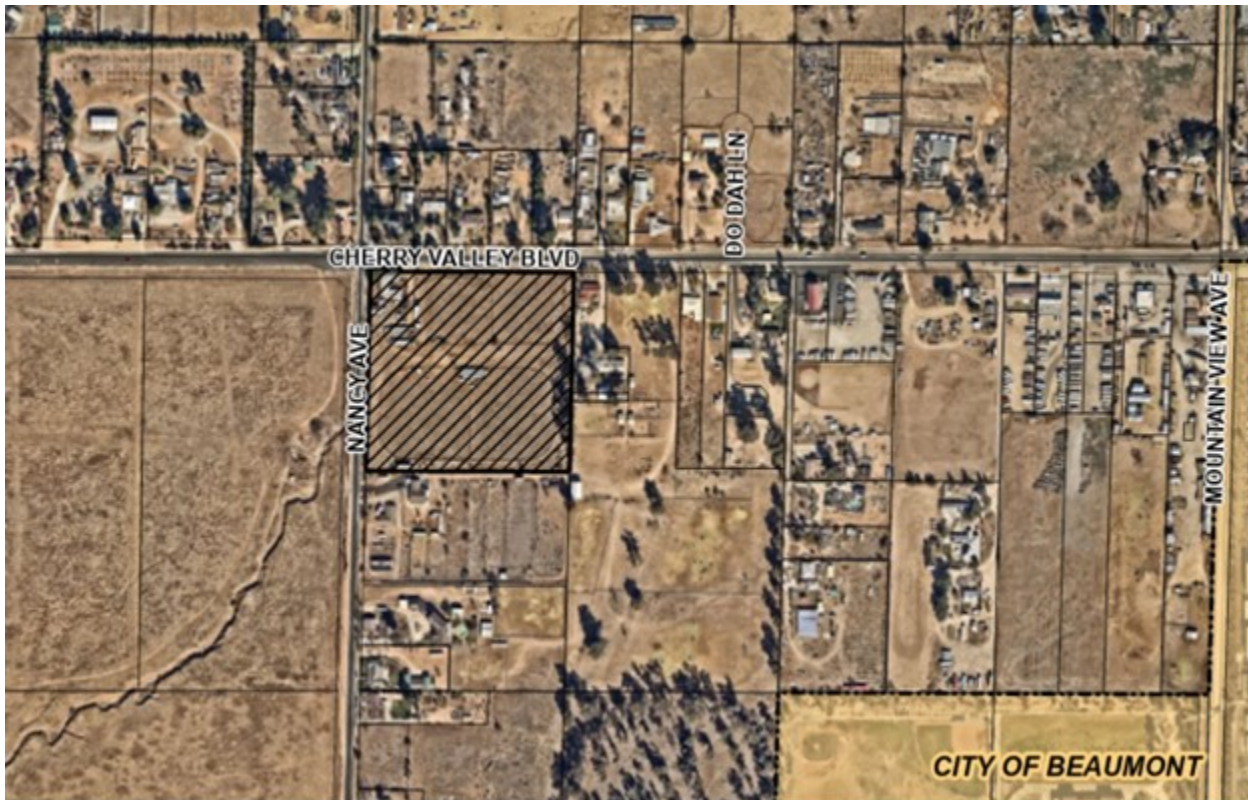

Figure 1: Project Location Map

PROJECT BACKGROUND AND ANALYSIS

Background

The proposed Foundation Component General Plan Amendment (FC-GPA) is an initiation procedure per the General Plan which occurs in eight (8) year cycles, most recently occurring in 2024. All property owners and applicants wanting to change their Foundation Components are required to submit their proposals for land use designation changes to the County of Riverside for consideration and possible initiation by the Board of Supervisors.

Further determination of zoning classifications, neighborhood compatibility, and other development factors or findings shall be made if the proposed FC-GPA (GPA240052) is initiated by the Board of Supervisors. Any initiated FC-GPA, by the Board of Supervisors, will require the submittal of an implementing project within six (6) months from initiation.

Applicant Proposal

FC-GPA240052 is a proposal to change the Foundation Component Land Use Designation from Rural Community: Very Low Density Residential (RC: VLDR) to Community Development: Low

**COUNTY OF RIVERSIDE PLANNING DEPARTMENT
STAFF REPORT**

Density Residential (CD: LDR). The parcel is located in the Cherry Valley Policy Area, within The Pass Area Plan.

If FC-GPA240052 is approved by the Board of Supervisors, the applicant intends to apply for an implementing project consisting of sixteen (16) custom homes on a half-acre (0.5) lot.

Proposed Future Land Use

The proposed Community Development (CD) Foundation encompasses many underlying land use designations. The most intensive land use designation permitted within the CD Foundation is the Heavy Industrial (CD-HI) land use designation, which allows for more intense industrial activities that generate greater effects such as excessive noise, dust, and other nuisances.

The proposed Low Density Residential (CD: LDR) Land Use designation is intended to allow for the development of detached single family residential dwelling units on large parcels of .5 to 1 acre. Limited agriculture and animal keeping is permitted, however, intensive animal keeping is discouraged. The density range allows for up to 1 dwelling unit per .5 acre.

Changes to Applicant Proposal

After presentation of the project proposal to the GPAC, the Applicant submitted a change to the proposal that is reflected in this staff report. The previous proposal that was considered at the GPAC public hearing was for a change from Rural Community: Very Low Density Residential (RC: VLDR) to Community Development: High Density Residential (CD: HDR) to allow for submittal of an application for a mobile home park with up to 92 lots containing 8 - 10 homes per acre. The new proposal is reflected above and in the Applicant's Exhibit E.

PUBLIC HEARING NOTIFICATION AND COMMUNITY OUTREACH

This project was advertised on the Riverside County Planning Department website. Additionally, public hearing notices in English and Spanish, pursuant to department policy and in accordance with the requirements of Ordinance 348, were mailed to property owners within 600 feet of the project site the General Plan Advisory Committee. Planning Staff has received written communication from 8 who indicated opposition to the proposed project.

No comments were received as of the drafting of this staff report.

One (1) comment was received after the close of the GPAC public hearing and as of the writing of this staff report. Those comments indicated concerns about traffic, infrastructure, and losing their way of life.

General Plan Advisory Committee Proceedings

**COUNTY OF RIVERSIDE PLANNING DEPARTMENT
STAFF REPORT**

A duly noticed public hearing to discuss FC-GPA240052 was held before the General Plan Advisory Committee on May 12, 2025. Eight (8) comments were submitted before the General Plan Advisory Committee meeting. At that public hearing, the applicant presented their request for the proposal, the Committee opened the hearing for public comments, and two (2) members of the public provided public testimony.

Of the public comments received, both were against initiation of a General Plan Amendment, and none were in support. Comments against the initiation of the GPA cited traffic concerns, multiple trailer parks, strain on the infrastructure, the rural lifestyle, and the effect on property values.

The Committee discussed concerns about a mobile home park with high density fitting in with the area.

The final result of the Committee's discussion of the initiation is provided below.

Support: N/A
Against: 2nd Districts
Neutral: N/A
Not Present: 1st, 3rd, 4th, and 5th District
Abstain: N/A

ATTACHMENTS

- Exhibit A – Vicinity Maps**
- Exhibit B – Existing Land Use Designations**
- Exhibit C – Existing Zoning Classifications**
- Exhibit D – Noticing Radius and Labels**
- Exhibit E – Applicant's Exhibits**
- Exhibit F – GPAC Hearing Package**

RIVERSIDE COUNTY PLANNING DEPARTMENT

GPA240052

VICINITY/POLICY AREAS

Supervisor: YXSTIAN GUTIERREZ

Date: 2-11-2025

District: 5

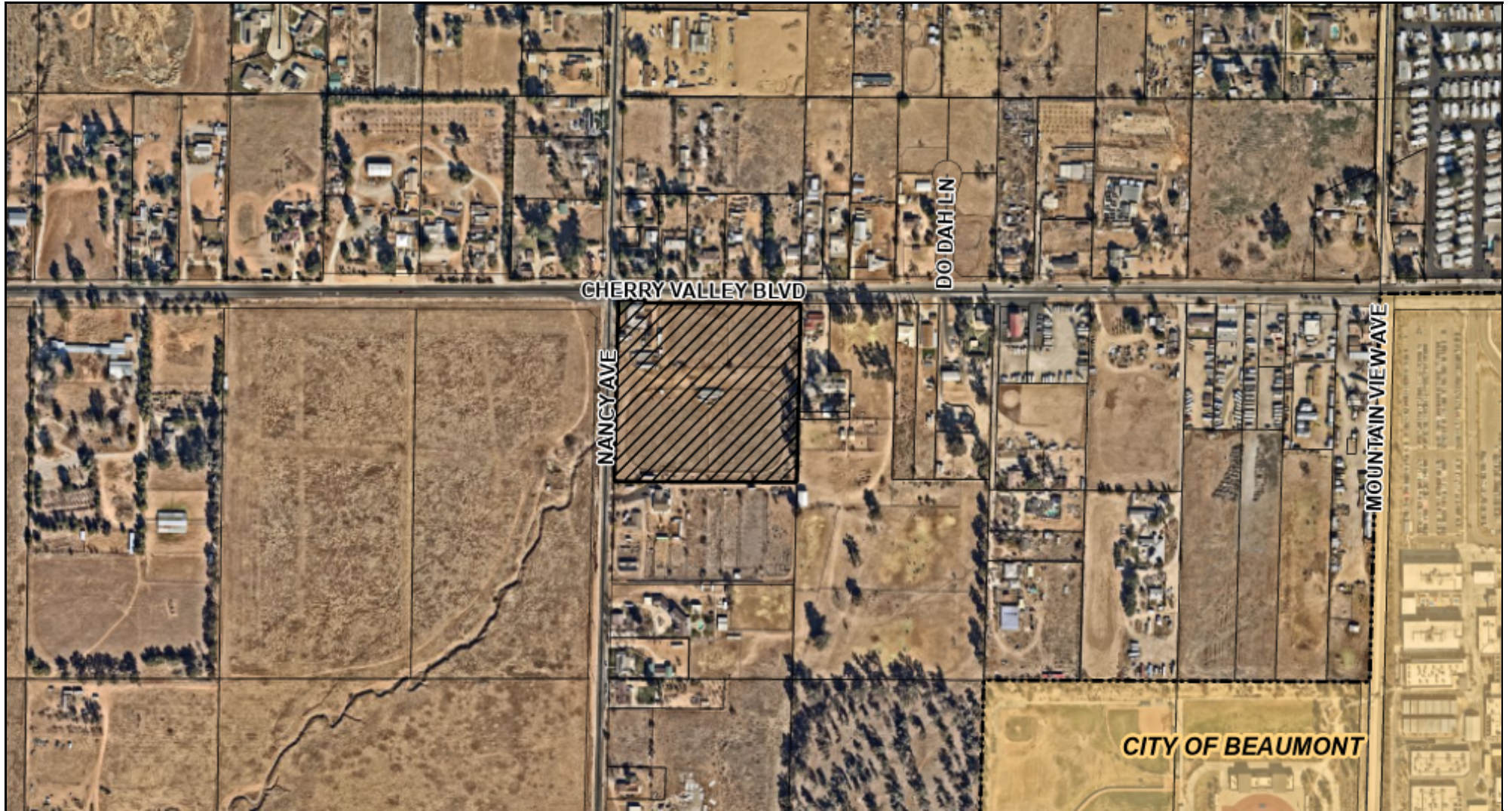

Zoning Area/District: CHERRY VALLEY

DISCLAIMER: On October 7, 2003, the County of Riverside adopted a new General Plan providing new land use designations for unincorporated Riverside County parcels. The new General Plan may contain different type of land use than is provided for under existing zoning. For further information, please contact the Riverside County Planning Department offices in Riverside at (951)955-3200 (Western County) or in Palm Desert at (760)863-8277 (Eastern County) or Website <http://planning.rctlma.org>

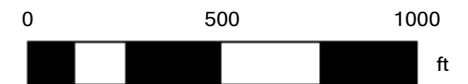

Foundation Component GPA Cycle Map

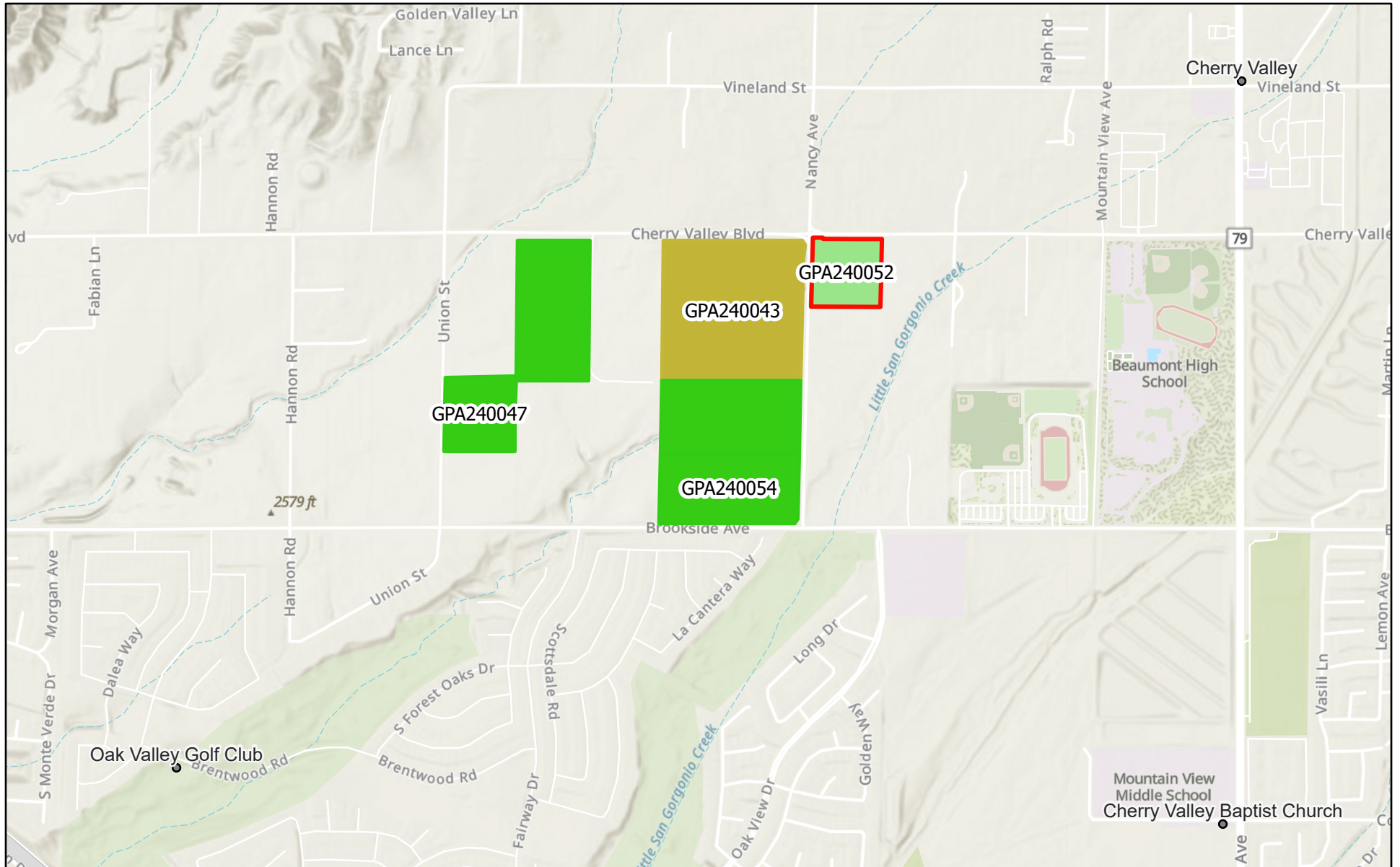

4/28/2025, 1:29:25 PM

 FGPA Web Map _Query result

 California Geographic Names Information System

FGPA Web Map

 Active

 On Hold

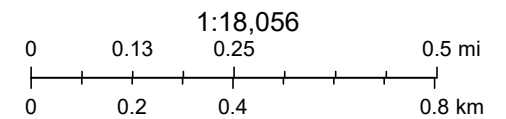

Esri, NASA, NGA, USGS, FEMA, Sources: Esri, TomTom, Garmin, FAO, NOAA, USGS, © OpenStreetMap contributors, and the GIS User Community

TLMA - Planning

RIVERSIDE COUNTY PLANNING DEPARTMENT

GPA240052

EXISTING GENERAL PLAN

Supervisor: YXSTIAN GUTIERREZ

Date: 2-13-2025

District: 5

Exhibit: 5

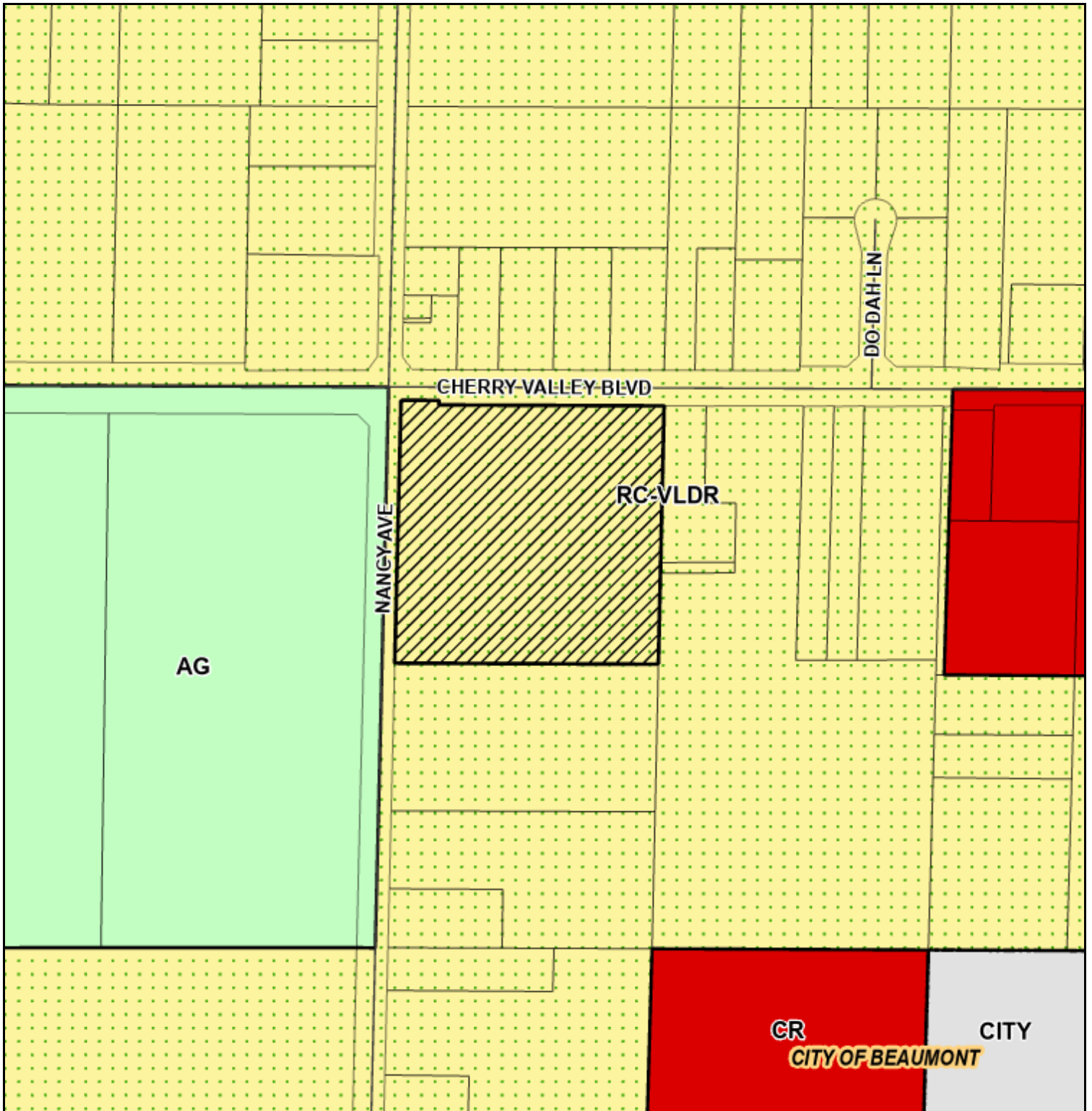

Zoning Area/District: CHERRY VALLEY

Author:

DISCLAIMER: On October 7, 2003, the County of Riverside adopted a new General Plan providing new land use designations for unincorporated Riverside County parcels. The new General Plan may contain different type of land use than is provided for under existing zoning. For further information, please contact the Riverside County Planning Department offices in Riverside at (951)955-3200 (Western County) or in Palm Desert at (760)863-8277 (Eastern County) or Website <http://planning.rctlma.org>

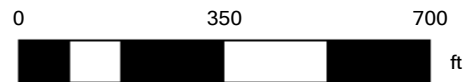

RIVERSIDE COUNTY PLANNING DEPARTMENT

GPA240052

EXISTING ZONING

Supervisor: YXSTIAN GUTIERREZ

District: 5

Date: 2-13-2025

Exhibit: 2

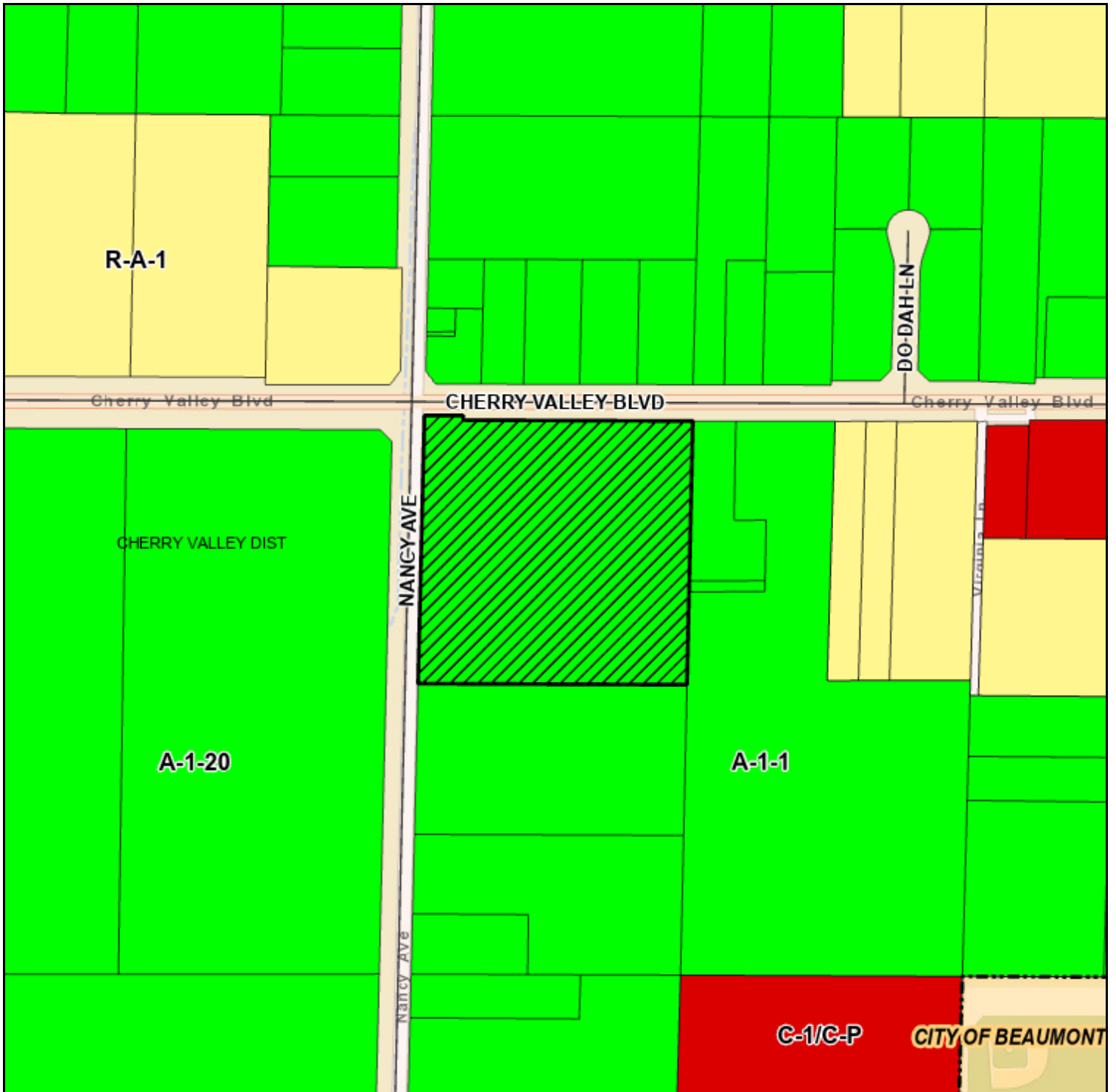

Zoning Area/District: CHERRY VALLEY

DISCLAIMER: On October 7, 2003, the County of Riverside adopted a new General Plan providing new land use designations for unincorporated Riverside County parcels. The new General Plan may contain different type of land use than is provided for under existing zoning. For further information, please contact the Riverside County Planning Department offices in Riverside at (951)955-3200 (Western County) or in Palm Desert at (760)863-8277 (Eastern County) or Website <http://planning.rctlma.org>

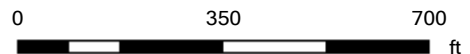



John E. Hildebrand
Planning Director

RIVERSIDE COUNTY

PLANNING DEPARTMENT

CERTIFICATION OF PUBLIC NOTICE

PROJECT NUMBER (FC-GPA240052)

Planning Case APN(s): 405-180-006

I, Edward Lincoln certify that on April 28, 2025, the attached property owners list was prepared pursuant to notification procedures in Subsection 1.7.A.3. of Ordinance 348. Attached list is a complete and true compilation of the owners of the subject property and all other property owners within 600 feet of the property involved.

I further certify that the information filed is true and correct to the best of my knowledge.

NAME: Edward Lincoln
TITLE: Associate Planner
ADDRESS: 4080 Lemon St 12th Fl., Riverside, CA 92501
PHONE: 951-955-8514
EMAIL: elincoln@rivco.org

SIGNATURE: *Edward Lincoln*

Riverside County GIS Mailing Labels

GPA240052

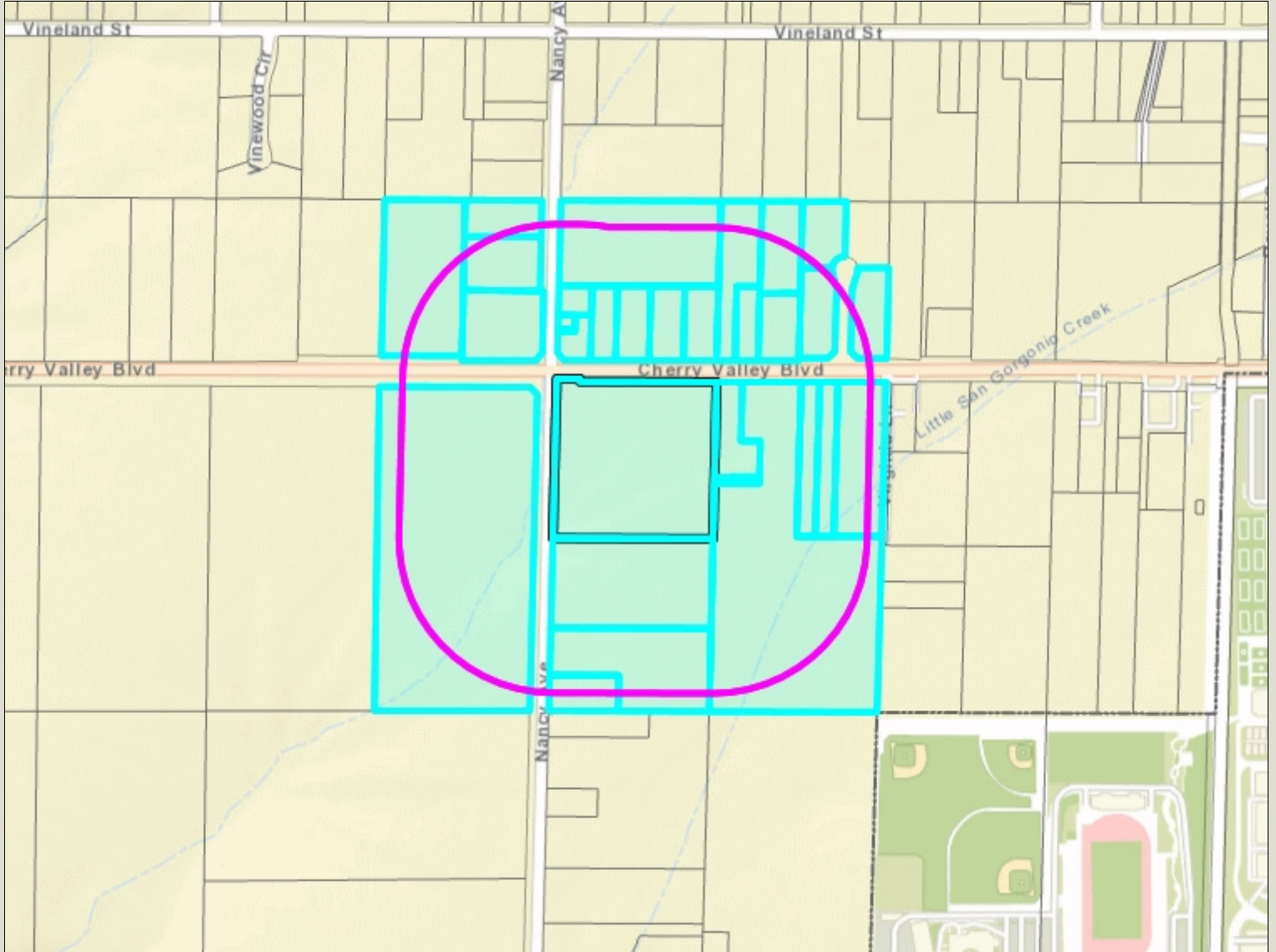

Legend

- County Boundary
- Cities
- Parcels
- World Street Map

Notes



0 752 1,505 Feet

IMPORTANT Maps and data are to be used for reference purposes only. Map features are approximate, and are not necessarily accurate to surveying or engineering standards. The County of Riverside makes no warranty or guarantee as to the content (the source is often third party), accuracy, timeliness, or completeness of any of the data provided, and assumes no legal responsibility for the information contained on this map. Any use of this product with respect to accuracy and precision shall be the sole responsibility of the user.

REPORT PRINTED ON... 2/13/2025 9:24:02 AM

© Riverside County RCIT

405110001
WILLIAM K. LATTIN
9824 JONATHAN AVE
CHERRY VALLEY CA 92223

405110002
WILLIAM M. SIMPSON
40666 DUTTON
BEAUMONT CA 92223

405110012
GRACIELA ESTRADA
38656 CHERRY VALLEY BLV
BEAUMONT CA 92223

405110017
CHRISTOPHER LINDEN ASHTON
38648 CHERRY VALLEY BLVD
BEAUMONT CA 92223

405110018
JOSE PEREZ
38610 CHERRY VALLEY BLVD
BEAUMONT CA 92223

405110019
DARREN SURIO CASTILLO
38656 CHERRY VALLEY BLVD
BEAUMONT CA 92223

405110020
CURTIS BURHOP
38620 CHERRY VALLEY BLVD
BEAMO NT 92223

405110021
CLAUDIA JEAN NEWMAN
10498 NANCY AVE
BEAUMONT CA 92223

405110022
JOSHUA J. SHELLEY
38678 CHERRY VALLEY BLVD
CHERRY VALLEY CA 92223

405110025
EDDY S. AYALA
38634 CHERRY VALLEY BLVD
BEAUMONT CA 92223

405110026
WILLIAM M. SIMPSON
245 N LITCHFIELD RD 142
GOODYEAR AZ 85338

405110028
MOHAMMAD ASLAM
13088 SOUTH LN
REDLANDS CA 92373

405110030
DAN L. MARVIN
38690 CHERRY VALLEY BLVD
BEAUMONT CA 92223

405170008
DARREN BONETTI
10427 NANCY AVE
BEAUMONT CA 92223

405170009
APPA INV
11134 DAYLILLY ST
FONTANA CA 92337

405170012
JOHN L. KERN
38456 CHERRY VALLEY BLVD
BEAUMONT CA 92223

405170014
HOUSE OF DECISION OPPORTUNITY
38416 CHERRY VALLEY BLVD
CHERRY VALLEY CA 92223

405180003
KRISTINA M. VANDERBRUG
P O BOX 590
BEAUMONT CA 92223

405180004
RONDA L. DINKINS
10756 NANCY AVE
CHERRY VALLEY CA 92223

405180006
OM JOSHUA
904 SILVER SPUR NO 479
ROLLING HILLS CA 90274

405180008
ATENCIO FAMILY TRUST DATED
04/10/2023
10664 NANCY AVE
BEAUMONT CA 92223

405190006
FLOREN ERIK DAVID REVOCABLE
TRUST
38745 CHERRY VALLEY BLVD
BEAUMONT CA 92223

405190007
IRMA NAVA
48712 DESERT FLOWER DR
PALM DESERT CA 92260

405190008
ELIAS BALDERRAMA
38705 CHERRY VALLEY BLVD
CHERRY VALLEY CA 92223

405190010
OSTER MARK A
38649 CHERRY VALLEY BLV
BEAUMONT CA 92223

405190014
MARK A. OSTER
38649 CHERRY VALLEY BLVD
CHERRY VALLEY CA 92223

405250007
CHERRY VALLEY PARTNERS
32036 LIVE OAK CANYON RD
REDLANDS CA 92373

CHERRY

VALLEY

BLVD.

AVENUE

NANCY

EXISTING HOUSE

1

2

3

4

16

15

14

5

11

12

13

6

10

9

8

7

44'

56'

56'

56'

N

0 50 75 100
GRAPHIC SCALE: 1"=50'

OWNER:

OM JOSHUA LLP
904 SILVER SPUR #479
ROLLING HILLS ESTATES, CA 90274
APN 405-108-006